



**NAVAL  
POSTGRADUATE  
SCHOOL**

**MONTEREY, CALIFORNIA**

**THESIS**

**POTENTIAL STANDARDS AND METHODS FOR THE  
NATIONAL GUARD'S HOMELAND RESPONSE FORCE**

by

Christian M. Van Alstyne

September 2011

Thesis Advisor:  
Second Reader:

Robert Simeral  
Stanley Supinski

**Approved for public release; distribution is unlimited**

THIS PAGE INTENTIONALLY LEFT BLANK

| <b>REPORT DOCUMENTATION PAGE</b>  |  |  | <i>Form Approved OMB No. 0704-0188</i>   |   |
|---|--|--|--|---|
| Public reporting burden for this collection of information is estimated to average 1 hour per response, including the time for reviewing instruction, searching existing data sources, gathering and maintaining the data needed, and completing and reviewing the collection of information. Send comments regarding this burden estimate or any other aspect of this collection of information, including suggestions for reducing this burden, to Washington headquarters Services, Directorate for Information Operations and Reports, 1215 Jefferson Davis Highway, Suite 1204, Arlington, VA 22202-4302, and to the Office of Management and Budget, Paperwork Reduction Project (0704-0188) Washington DC 20503.   |  |  |  |   |
| <b>1. AGENCY USE ONLY (Leave blank)</b>   |  | <b>2. REPORT DATE</b><br>September 2011                        | <b>3. REPORT TYPE AND DATES COVERED</b><br>Master's Thesis   |   |
| <b>4. TITLE AND SUBTITLE</b> Potential Standards and Methods for the National Guard's Homeland Response Force   |  |  | <b>5. FUNDING NUMBERS</b>  |   |
| <b>6. AUTHOR(S)</b> Christian M. Van Alstyne  |  |  | <b>8. PERFORMING ORGANIZATION REPORT NUMBER</b>  |   |
| <b>7. PERFORMING ORGANIZATION NAME(S) AND ADDRESS(ES)</b><br>Naval Postgraduate School<br>Monterey, CA 93943-5000   |  |  | <b>10. SPONSORING/MONITORING AGENCY REPORT NUMBER</b>  |   |
| <b>9. SPONSORING /MONITORING AGENCY NAME(S) AND ADDRESS(ES)</b><br>N/A  |  |  | <b>11. SUPPLEMENTARY NOTES</b> The views expressed in this thesis are those of the author and do not reflect the official policy or position of the Department of Defense or the U.S. Government. IRB Protocol number _____ N/A_____ |   |
| <b>12a. DISTRIBUTION / AVAILABILITY STATEMENT</b><br>Approved for public release; distribution is unlimited   |  |  | <b>12b. DISTRIBUTION CODE</b><br>A   |   |
| <b>13. ABSTRACT (maximum 200 words)</b><br>In 2009, the Office of the Secretary of Defense directed the creation of 10 National Guard Homeland Response Force (HRF) units to provide regional chemical biological radiological nuclear and explosive (CBRNE) and disaster response in each of the 10 FEMA regions beginning in September 2011. The HRF was selected to fill a regional CBRNE capability gap. The HRF concept is a 566-person National Guard unit tasked to provide command, CBRNE assessment, decontamination, casualty care, logistics, security, and rescue in support of civilian officials during a regional-level CBRNE event or disaster. With domestic response mission and overseas deployment requirements, the HRF faces the difficult challenge of meeting both civilian response and military battlefield standards. Although some DoD organizations have had similar domestic response missions, no precedent for the HRF exists. The HRF reflects an evolution of military units with CBRNE and disaster related missions beginning in the 1990s. Government and private criticisms of these previous DoD CBRNE include wasted tax dollars, poor training strategies, and poor links to National Planning Scenarios. This thesis provides lessons learned from case studies of previous U.S. and Israeli CBRNE and disaster response organizations while recommending standards that the new HRF can use for improved implementation. |  |  |  |   |
| <b>14. SUBJECT TERMS</b> CBRNE, Civil Support Operations, Defense Support to Civil Authorities, Civil Support Teams, CBRNE Consequence Management Response Force, Chemical Biological Radiological Nuclear Explosive, CBRNE Enterprise, Weapons of Mass Destruction, National Guard, HRF, Homeland Response Force, CCMRF, weapons of mass destruction   |  |  | <b>15. NUMBER OF PAGES</b><br>90   |   |
| <b>17. SECURITY CLASSIFICATION OF REPORT</b><br>Unclassified  |  |  | <b>16. PRICE CODE</b>  |   |
| <b>18. SECURITY CLASSIFICATION OF THIS PAGE</b><br>Unclassified   |  | <b>19. SECURITY CLASSIFICATION OF ABSTRACT</b><br>Unclassified |  | <b>20. LIMITATION OF ABSTRACT</b><br>UU |

THIS PAGE INTENTIONALLY LEFT BLANK

**Approved for public release; distribution is unlimited**

**POTENTIAL STANDARDS AND METHODS FOR THE NATIONAL GUARD'S  
HOMELAND RESPONSE FORCE**

Christian M. Van Alstyne  
Lieutenant Colonel, National Guard  
B.A., University of Washington, 1989  
M.S., Central Michigan University, 1999

Submitted in partial fulfillment of the  
requirements for the degree of

**MASTER OF ARTS IN SECURITY STUDIES  
(HOMELAND SECURITY AND DEFENSE)**

from the

**NAVAL POSTGRADUATE SCHOOL  
September 2011**

Author: Christian M. Van Alstyne

Approved by: Robert Simeral  
Thesis Advisor

Stanley Supinski  
Second Reader

Harold A. Trinkunas, Ph.D.  
Chair, National Security Affairs

THIS PAGE INTENTIONALLY LEFT BLANK

## **ABSTRACT**

In 2009, the Office of the Secretary of Defense directed the creation of 10 National Guard Homeland Response Force (HRF) units to provide regional chemical biological radiological nuclear and explosive (CBRNE) and disaster response in each of the 10 FEMA regions beginning in September 2011. The HRF was selected to fill a regional CBRNE capability gap. The HRF concept is a 566-person National Guard unit tasked to provide command, CBRNE assessment, decontamination, casualty care, logistics, security, and rescue in support of civilian officials during a regional-level CBRNE event or disaster. With domestic response mission and overseas deployment requirements, the HRF faces the difficult challenge of meeting both civilian response and military battlefield standards. Although some DoD organizations have had similar domestic response missions, no precedent for the HRF exists. The HRF reflects an evolution of military units with CBRNE and disaster related missions beginning in the 1990s. Government and private criticisms of these previous DoD CBRNE include wasted tax dollars, poor training strategies, and poor links to National Planning Scenarios. This thesis provides lessons learned from case studies of previous U.S. and Israeli CBRNE and disaster response organizations while recommending standards that the new HRF can use for improved implementation.

THIS PAGE INTENTIONALLY LEFT BLANK



# TABLE OF CONTENTS

|             |  |           |
|-------------|--|-----------|
| <b>I.</b>   | <b>IMPLEMENTATION STANDARDS FOR THE NATIONAL GUARD’S<br/>HOMELAND RESPONSE FORCE .....</b> | <b>1</b>  |
| <b>A.</b>   | <b>PROBLEM STATEMENT .....</b>   | <b>1</b>  |
| <b>B.</b>   | <b>RESEARCH QUESTION .....</b>   | <b>2</b>  |
| <b>C.</b>   | <b>SIGNIFICANCE OF THE RESEARCH.....</b>   | <b>3</b>  |
| <b>D.</b>   | <b>LITERATURE REVIEW .....</b>   | <b>3</b>  |
|             | <b>1. Fiction.....</b>   | <b>4</b>  |
|             | <b>2. Nonfiction.....</b>  | <b>5</b>  |
|             | <b>3. Policy .....</b>   | <b>6</b>  |
|             | <b>4. DoD Literature and Doctrine.....</b>   | <b>7</b>  |
|             | <b>5. GAO Audits .....</b>   | <b>8</b>  |
| <b>E.</b>   | <b>HYPOTHESES .....</b>  | <b>9</b>  |
| <b>F.</b>   | <b>METHODOLOGY .....</b>   | <b>10</b> |
| <b>G.</b>   | <b>HOMELAND RESPONSE FORCE BACKGROUND<br/>INFORMATION.....</b>                             | <b>11</b> |
| <b>II.</b>  | <b>PREVIOUS DOD CBRNE AND ALL-HAZARDS RESPONSE<br/>ORGANIZATIONS .....</b>                 | <b>15</b> |
| <b>A.</b>   | <b>THE CHEMICAL BIOLOGICAL INCIDENT RESPONSE FORCE ....</b>                                | <b>16</b> |
| <b>B.</b>   | <b>THE CIVIL SUPPORT TEAM.....</b>   | <b>17</b> |
| <b>C.</b>   | <b>THE CBRNE ENHANCED RESPONSE FORCE PACKAGE .....</b>                                     | <b>21</b> |
| <b>D.</b>   | <b>THE CBRNE CONSEQUENCE MANAGEMENT RESPONSE<br/>FORCE.....</b>                            | <b>26</b> |
| <b>E.</b>   | <b>LESSONS FROM PREVIOUS CBRNE ORGANIZATIONS .....</b>                                     | <b>29</b> |
| <b>III.</b> | <b>CIVILIAN AND MILITARY LAWS AND PRACTICES FOR THE HRF .....</b>                          | <b>33</b> |
| <b>A.</b>   | <b>PPD-8 AND PLANNING GUIDELINES .....</b>   | <b>34</b> |
| <b>B.</b>   | <b>DOMESTIC HAZMAT AND CBRNE RESPONSE LAWS .....</b>                                       | <b>35</b> |
| <b>C.</b>   | <b>INTELLIGENCE OVERSIGHT AND INCIDENT AWARENESS<br/>AND ASSESSMENT .....</b>              | <b>39</b> |
| <b>D.</b>   | <b>THE POSSE COMITATUS ACT AND THE INSURRECTION ACT...41</b>                               |           |
| <b>IV.</b>  | <b>CASE STUDY: THE ISRAELI HOME FRONT COMMAND .....</b>                                    | <b>45</b> |
| <b>A.</b>   | <b>ISRAELI HISTORY AND EXPERIENCE.....</b>   | <b>47</b> |
| <b>B.</b>   | <b>CREATION OF THE HOME FRONT COMMAND .....</b>  | <b>48</b> |
| <b>C.</b>   | <b>COMPARISONS: THE HOME FRONT COMMAND AND U.S.<br/>NATIONAL GUARD .....</b>               | <b>52</b> |
| <b>V.</b>   | <b>RECOMMENDATIONS AND CONCLUSIONS FOR THE HRF .....</b>                                   | <b>57</b> |
| <b>A.</b>   | <b>A POTENTIAL HRF RESPONSE SCENARIO .....</b>   | <b>57</b> |
| <b>B.</b>   | <b>RECOMMENDATIONS.....</b>  | <b>60</b> |
|             | <b>1. Technologies and IAA.....</b>  | <b>60</b> |
|             | <b>2. Mission Scope and Flexibility .....</b>  | <b>61</b> |
|             | <b>3. Collaboration and Plans .....</b>  | <b>61</b> |

|    |  |    |
|----|--|----|
| 4. | Civil Liberties .....                          | 63 |
| 5. | Examples from Israel's Home Front Command..... | 63 |
| C. | CONCLUSIONS .....                              | 63 |
|    | LIST OF REFERENCES .....                       | 67 |
|    | INITIAL DISTRIBUTION LIST .....                | 73 |

## LIST OF FIGURES

|            |   |    |
|------------|---|----|
| Figure 1.  | HRF Literature Overview and Sources.....  | 4  |
| Figure 2.  | OSD Policy Hybrid Alternative (From Office of the Secretary of Defense, 2009) .....               | 12 |
| Figure 3.  | HRF Structure and Operational Concept (From National Guard Bureau 2009) .....                     | 13 |
| Figure 4.  | CBIRF Task Organization (From CBIRF, 2008) .....  | 16 |
| Figure 5.  | Civil Support Team (From Hudoba & Reese, 2007) .....  | 18 |
| Figure 6.  | CERFP Organization (From Hudoba & Reese, 2007).....   | 23 |
| Figure 7.  | CERFP Team National Coverage (From Hudoba & Reese, 2007) .....                                    | 23 |
| Figure 8.  | CCMRF Structure (From Anderson, 2009) .....   | 26 |
| Figure 9.  | The CBRN Enterprise (From National Guard Bureau & U.S. NORTCOM, 2011) .....                       | 29 |
| Figure 10. | The National Oil and Hazardous Substances Pollution Contingency Plan (NCP) (From EPA, 2011) ..... | 36 |
| Figure 11. | National Guard Bureau and NORTHCOM Conference Products (From National Guard Bureau, 2010).....    | 38 |
| Figure 12. | HFC Districts (From Israeli Defense Forces, n.d. b) .....   | 49 |
| Figure 13. | HFC Organizational and Operational Regional Structures (From IDF, n.d. b) .....                   | 50 |
| Figure 14. | HRF Collaboration & Response Spectrum .....   | 62 |

THIS PAGE INTENTIONALLY LEFT BLANK

## LIST OF TABLES

|          |  |    |
|----------|--|----|
| Table 1. | HRF Recommended Civilian Response Standards..... | 37 |
| Table 2. | HRF and HFC Capabilities .....                   | 54 |

THIS PAGE INTENTIONALLY LEFT BLANK

## LIST OF ACRONYMS AND ABBREVIATIONS

|        |  |
|--------|--|
| ACLU   | American Civil Liberties Union                         |
| ACP    | Area Contingency Plan                                  |
| CBIRF  | Chemical, Biological, Incident Response Force          |
| CCMRF  | CBRNE Consequence Management Response Force            |
| CBRNE  | Chemical Biological Radiological Nuclear and Explosive |
| CERCLA | Comprehensive Environmental Compensation Liability Act |
| COP    | Common Operating Picture                               |
| CST    | National Guard's Civil Support Teams                   |
| CSTWG  | Civil Support Team Working Group                       |
| DCRF   | Defense Consequence Management Response Force          |
| DoD    | Department of Defense                                  |
| EOD    | Explosive Ordnance Detachment                          |
| EMAC   | Emergency Management Assistance Compacts               |
| EPA    | Environmental Protection Agency                        |
| FEMA   | Federal Emergency Management Agency                    |
| FM     | Field Manual   |
| FOSC   | Federal On-Scene Coordinators                          |
| FOUO   | For Official Use Only                                  |
| GAO    | Government Accountability Office                       |
| GIS    | Geospatial Information Systems                         |
| HAZMAT | Hazardous Materials                                    |
| HRF    | Homeland Response Force                                |
| HA'GA  | Hebrew Acronym Meaning Civil Defense                   |
| HSPDs  | Homeland Security Presidential Directives              |
| HFC    | Home Front Command                                     |
| IAA    | Incident Assessment and Awareness                      |
| IDF    | Israeli Defense Force                                  |
| ICS    | Incident Command System                                |
| IPB    | Intelligence Preparation of the Battlefield            |
| ISR    | Intelligence Surveillance and Reconnaissance           |

|          |   |
|----------|---|
| NCP      | National Contingency Plan                   |
| NFPA     | National Fire Protection Agency             |
| NIMS     | National Incident Management System         |
| NORTHCOM | U.S. Northern Command                       |
| NRF      | National Response Framework                 |
| NSSE     | National Special Security Event             |
| OSD      | Office of the Secretary of Defense          |
| OSHA     | Occupational Safety, Health, Administration |
| PAT      | Proficiency Analytical Test                 |
| PDD      | Presidential Decision Directive             |
| PPD      | Presidential Policy Directive               |
| RCP      | Regional Contingency Plan                   |
| SAR      | Search and Rescue                           |
| SIPR     | Secure Internet Protocol Router             |
| TCP      | Traffic Control Point                       |
| UAS      | Unmanned Aerial Systems                     |
| U.S.C.   | United States Code                          |
| VBIED    | Vehicle-Borne Improvised Explosive Device   |



THIS PAGE INTENTIONALLY LEFT BLANK

# **I. IMPLEMENTATION STANDARDS FOR THE NATIONAL GUARD'S HOMELAND RESPONSE FORCE**

## **A. PROBLEM STATEMENT**

Based on the 2010 *Quadrennial Defense Review* and Office of the Secretary of Defense (OSD) decisions, 10 new 566-person domestic chemical biological radiological nuclear and explosive (CBRNE) and all-hazards response organizations are being created to meet regional response requirements beginning in September 2011 (Office of the Secretary of Defense, 2009). Falling under the National Guard, these 10 new Homeland Response Force (HRF) units will face challenges both new and similar to past Department of Defense (DoD) response organizations. The careful selection of military and civilian response standards and an examination of lessons from other military CBRNE and disaster response organizations are essential to developing HRFs that are able to meet expectations and support America's responders. The HRFs \$156 million annual budget also makes the proper selection of HRF mission roles and standards essential to avoid wasting taxpayer dollars (M. Reese, personal communication, December 18, 2009).

America's elected officials and public have developed strong expectations of military support during significant domestic emergencies. These expectations match a trend beginning in the 1990s with legislative measures, creation of dedicated military domestic response organizations, and the military's response to disasters. Hurricanes Andrew, Katrina, Ike, and Gustav are natural disasters that involved thousands of Department of Defense personnel. The World Trade Center and Pentagon incidents also involved immediate DoD response and thousands of DoD personnel securing airports nationwide. The Nunn-Lugar-Domenici Act, Presidential Decision Directive (PDD)-39, and PDD-63 are legislative and executive actions that expanded DoD's domestic response roles and created DoD CBRNE and all-hazard response units.

Operating within the United States and its territories, the HRF must meet legally mandated civilian response standards for its command, medical, CBRNE, and search and rescue (SAR) elements. Employed by federal and state response agencies, these include

the Occupational Safety, Health, Administration (OSHA), Environmental Protection Agency (EPA), and National Fire Protection Agency (NFPA) legal requirements and guidelines provide criteria for domestic response operations. In addition to providing response standards, these requirements also provide common practices used by agencies the HRF will support during an incident. The HRFs advanced classified information sharing and communications systems could raise intelligence oversight and civil-liberty concerns regarding DoD conducting domestic intelligence activities. The HRFs security element will also face scrutiny for potential civil-liberty and Posse Comitatus Act violations. Additional Homeland Security Presidential Directives (HSPDs) and Presidential Policy Directives (PPDs) specify response and planning guidelines that the HRF must follow to effectively complement federal and state agencies.

Funded and organized by the DoD through the National Guard, the “dual-missioned” HRF must also simultaneously meet DoD standards for worldwide deployment for combat operations. Much of the HRF’s future organization and capabilities will fall under DoD’s existing architecture for developments in training, equipment, and funding. Military standards will be essential to the areas of pay, education, promotion, and routine administration of the HRF.

## **B. RESEARCH QUESTION**

The thesis will identify methods and standards to build a new regional DoD CBRNE response organization given potential gaps between DoD’s battlefield oriented doctrine and existing U.S. statutory response guidelines used by civilian responders. The intent of the thesis is to address this primary question:

Based on the experiences of previous CBRNE and disaster response organizations, what standards and practices are appropriate to developing the HRF in order to best integrate its DoD capabilities with existing civilian CBRNE and all-hazard response capabilities?

The following supplementary questions related to the development of the HRF will be examined in the course of addressing the primary research question:

1. What lessons do previous CBRNE and disaster response forces provide that can benefit the new HRF?

2. What civilian and military response standards are applicable to the HRF regional response mission?
3. What guidance exists for the HRF's proper employment of advanced classified communication systems and information sharing capabilities without violating intelligence oversight laws?

### **C. SIGNIFICANCE OF THE RESEARCH**

Helping to create an HRF that can more effectively work with existing organizations to save lives and contribute to response operations during a large disaster or CBRNE event is the main thrust of this thesis. Identifying in advance what steps that DoD might take during the development phases of the HRF and prior to the commitment of hundreds of millions of dollars could help the HRF's initial effectiveness, save tax pay dollars, and avoid setbacks experienced in by previous DoD CBRNE efforts. To date, documents regarding the HRF have been PowerPoint concept documents or administrative in nature. This thesis will be one of the first written analysis documents examining proposed standards for the HRF and looks at lessons learned from previous organizations. As response organizations and leaders seek "common operating pictures" and as changes occur in social media and communications; the thesis also examines the HRF's potential practices to avoid increased intelligence oversight and civil liberties concerns. The primary audience of this thesis is America's response community who will respond with the HRF and DoD leaders working to develop the HRF.

### **D. LITERATURE REVIEW**

To date, material specific to the new 566-person HRF has yet been published in book or periodic form. Despite a lack of specificity of literature regarding the HRF, many works of fiction, nonfiction, Government Accountability Office (GAO) audits, policy documents, domestic intelligence policy, military doctrine, and public laws provide direct and tangential information cogent to the HRF concept. Literature categories, identified for this study of the HRF topic, can be categorized as fiction, nonfiction, editorial, military doctrine, GAO audits, public laws, and policy as sources of literature applicable to the HRF. This range of literature applicable to the HRF concept is broad, tangential, and, in cases very specific to the HRF, all at the same time. Important experiences from

similar DoD CBRNE organizations, such as the National Guard’s Civil Support Teams (CST) and the active military’s CBRNE Consequence Management Response Force (CCMRF), provide ample information for the HRF. Literature categories germane to the HRF are listed in Figure 1.

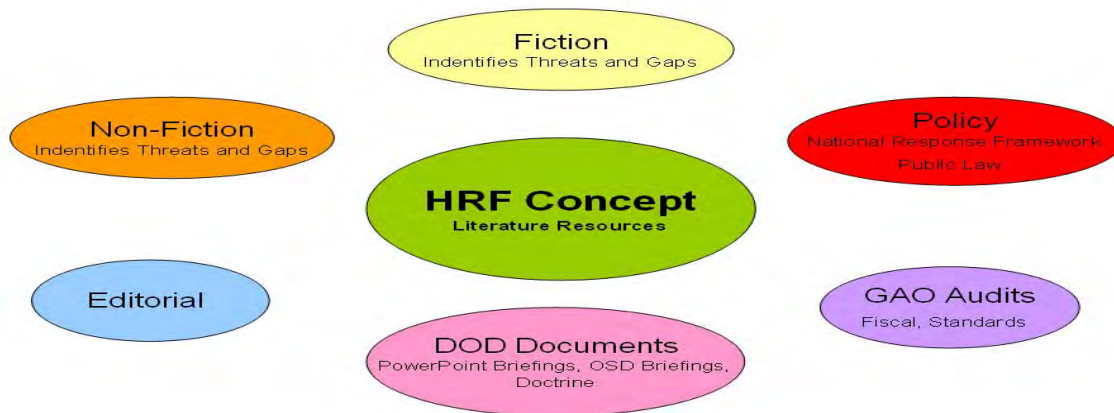

Figure 1. HRF Literature Overview and Sources

## 1. Fiction

Works of fiction are literature sources tangential to the HRF topic. Fiction has been instrumental to identifying CBRNE threats and gaps in response capabilities. The books *The Hot Zone* (1995) and *The Cobra Event* (1999) by Richard Preston were best-selling CBRNE related novels in the 1990s. The Preston books portrayed the terrible implications of biological incidents occurring in the United States. The books provide some factual information about people, agencies, and equipment as well as graphic depictions of biological agent impacts, such as victims eating their own flesh. Although his books were fiction and sensationalized, policymakers regarded his thoughts on biological threats to the U.S seriously. Preston’s *The Cobra Event* was cited by the *New York Times* as influencing President Bill Clinton to stimulate federal efforts to improve CBRNE response capabilities (Nash, 2004).

While works of fiction are inherently subjective, they can still demonstrate a perceived “gap” in preparedness and capture the public’s attention regarding potential scenarios that might threaten the average person. Though helping to portray a potential

threat, fictional works lack specific information regarding how local, state, and federal agencies might best manage the consequences of CBRNE incidents. Still, fiction has effectively conveyed catastrophic scenarios, demonstrated situations that government might not be prepared to handle, and has motivated authorities to address potential CBRNE scenarios.

## **2. Nonfiction**

Works of nonfiction CBRNE topics have tangential relevance to the HRF development. Nonfiction CBRNE books have also highlighted CBRNE threats to the United States and the world. Books, such as *Biohazard* (1999) by former Soviet scientist Ken Alibek and *Germs* (2001) by authors Judith Miller, Steven Engelberg, and William Broad, have examined actual CBRNE threats that the United States could face. Mr. Alibek, a Soviet defector, examines his work in the Soviet Union's biological weapons program between the 1970s and 1990s. The book *Germs* (Miller, 2001) examines a variety of terrorist biological threats to the United States as well as inability to effectively respond to the 1999 appearance of the West Nile virus in the U.S.

The non-fiction books have commonalities with the fiction category. Both sensationalize a threat, both paint scenarios that could happen, and both categories have influenced policy makers regarding CBRNE issues. Also, the nonfictional accounts are still subjective in nature. The books espouse the opinions of authors that have worked in parts of the CBRNE field. Mr Alibek's book revealed the previously unknown vast size of the U.S.S.R's biological weapons program and complemented devastation of the biological incident depicted in Richard Preston's *The Cobra Event* (2000). Judith Miller and her co-authors depicted a lack of U.S. preparedness yet simultaneously criticized DoD and administration efforts to address CBRNE shortcomings (2001). Some of this literature comes from the 1990s, matching a time period of Presidential Decision Directives related to CBRNE response.

Other literature regarding CBRNE threats is dated. Older nonfiction accounts focus on the Aum Shinrikyo cult, unsecured Soviet weapons stockpiles, and Saddam Hussein's weapons programs. More recent works focus on perceived threats such as Iran,

North Korea, and non-state actors employing CBRNE capabilities. In general, the non-fiction and fiction accounts are too CBRNE specific and lack mention of “all-hazards” disaster response capabilities that the HRF will provide.

### **3. Policy**

The policy category of literature available for the HRF topic provides the most objective sources of broad information regarding how the HRF might function. Both public law and guidelines form the policy category of this review. Examples of policy include the Homeland Security Presidential Directives Presidential (HSPDs), federal regulations, and public laws containing specific standards for hazardous materials response, safety, and all-hazards planning scenarios that are applicable to the HRF concept. A central framework to the HRF’s potential mission is the *National Response Framework* (NRF), (Department of Homeland Security, 2008), which is a sub-component of HSPD-5, “The Management of Domestic Incidents” (Department of Homeland Security [DHS], 2003). The NRF and other policy documents contain emergency support functions, interagency planning information, and information that can shape an HRF that functions as effectively with local, state, regional, and federal entities to incidents within the U.S. The Insurrection Act of 1807 (10 United States Code [U.S.C.] § 335) and the seemingly opposite Posse Comitatus Act of 1878 (18 U.S.C. § 1385) are profound laws that will impact the operations of HRF in domestic response mission. Both laws permit or restrict military domestic employments and have significant but different meanings to both federal forces working for the President and state-level National Guard force that typically answer to a governor.

While the policy category provides goals and standards, it lacks specifics to the HRF concept, such as organizational constructs, equipment selection, and availability for overseas deployments. Domestic U.S. policy does not mention how best to integrate the military’s doctrine, battlefield equipment, and often non-OSHA compliant work practices into a response.

Intelligence is a subcategory of policy with strong influence on military doctrine. Existing technologies and potential mission requirements can push the HRF into the

conflicted area of domestic intelligence and information sharing by DoD forces. This area is sensitive due to public concerns regarding the role of the military and civil liberties and was an issue during the 2007 and 2008 assignment of the CBRNE Consequence Management Response Force (CCMRF) under U.S. Northern Command (NORTHCOM). Given the HRF's regional CBRNE command and control mission, the HRF will use extensive communications and information technologies to help provide a common operating picture (COP.) An HRF with assigned CERFPs and CSTs may operate across large cities, state, or region rely upon a classified Secure Internet Protocol Router (SIPR) network that use the Trojan Spirit system, run thru Fort Belvoir, Virginia, to communicate. SIPR is widely used for both intelligence and information sharing. A CBRNE event could bring a significant need to receive and disseminate classified information with civilian and military agencies across hundreds of miles.

#### **4. DoD Literature and Doctrine**

The U.S. Army's For Official Use Only (FOUO) Training Circular (TC) 2-91.501 *Intelligence Handbook for Civil Support Operations* (Headquarters Department of the Army, 2009) will be essential to the HRF's proper employment of classified information and intelligence information. This document reflects both U.S. policy and military doctrine. The TC 2-91 provides methods to employ military aircraft, unmanned aerial systems (UAS) systems, and other intelligence related platforms in domestic role without violating U.S. laws regarding domestic intelligence operations (Headquarters Department of the Army, 2009). The TC 2-91 drops the commonly used DoD term intelligence preparation of the battlefield (IPB) for set of domestic terms that avoid the word intelligence altogether in favor of the term incident assessment and awareness (IAA), which seems to indicate information sharing and COP functions instead of *intelligence*. It also drops the term intelligence surveillance and reconnaissance (ISR) from domestic operations. *Transforming U.S. Intelligence* (Sims & Gerber, 2005) is another book appropriate to the HRF that describes the paradox on properly employing intelligence resources domestically while not undermining the institution of democracy or civil liberties. The chapter titled "Intelligence and Homeland Defense" from *Transforming*



*U.S. Intelligence* provides possible solutions to proper employment of intelligence resources that can speed a response to a domestic incident within the framework of a democracy (Sims & Gerber, 2005).

Military doctrine provides information from other DoD CBRNE response organizations that is immediately applicable to the HRF. Concepts for operational employment of the HRF, logistics support, equipment acquisition, and policy to integrate the HRF into a federal or state led response are found in doctrine. Doctrine includes manuals such as the Field Manual (FM) 3-28, *Civil Support Operations Manual* (Headquarters Department of the Army, 2010) and DoD Directive 3025 *Defense Support to Civil Authorities* (U.S. Department of Defense, 2011) provide information applicable to the HRF. Military knowledge centers such as the Army's Center for Lessons Learned (CALL) have also developed general disaster response handbooks pertinent to the HRF and its personnel.

Military doctrine can conflict with U.S. policies and laws regarding domestic CBRNE response. Doctrine is generated by the Secretary of Defense or subordinate DoD agencies to direct procedures for how units might function; however, doctrine cannot supplant U.S. laws. In many cases, doctrine and equipment developed for the battlefield might not meet OSHA and EPA requirements required to protect U.S. responders and the public. While doctrine is important to developing an HRF, it is important to remember that doctrine cannot replace statutory requirements used inside the U.S.

## **5. GAO Audits**

GAO audits provide important information regarding existing DoD CBRNE and all-hazards response organizations that precede the HRF. Two GAO audits address DoD CBRNE capabilities that the HRF will integrate or parallel in structure. A 2006 GAO audit of the National Guard's CSTs and a 2009 GAO audit of the NORTHCOM CBRNE Consequence Management Response Force both provide information essential to the HRF concept (U.S. Government Accountability Office [GAO], 2006; 2009). The GAO audits are detailed critiques that provide insights to the state-level CSTs and national-level CCMRF. These critiques might help focus the HRF as it builds a regional-level

capability. As a shortcoming, the GAO audits provide examples of what the HRF might avoid as opposed to what examples the HRF should follow. Also, the GAO audits provide little information on how a regional CBRNE and all-hazards response organization might best operate.

Presently, very little editorial literature exists on the HRF concept. Editorial literature on the CST and CCMRF as well as the Marine's Chemical, Biological, Incident Response Force (CBIRF) is prevalent. Like the GAO audits, much of this editorial is critical in nature and provides reactive guidance on what the HRF might avoid, instead of what the HRF might follow. Editorial on the HRF's predecessors can be found in DoD journals, civilian periodicals, and American Civil Liberties Union (ACLU) Websites. A heterogeneous nature and articulated opinions are the hallmark of editorial literatures. Editorial literature can provide critiques and insights not found in the homogenous military and policy literatures.

The HRF's regional CBRNE and all-hazards response mission is new, and so literature written specifically for the HRF does not exist; however, the existing literature provides policy, goals, and constructs importable to the HRF concept. Still much of this literature is focused on CBRNE and does not address the HRF's all-hazards response missions that might be found in New Madrid Seismic or a Japan-type earthquake scenario. However, much of the equipment, training, organizational design, and operations of these predecessors will be appropriate to new HRF. While the HRF is a new organization, experience from these legacy organizations will provide a pathway for development and construction of the HRF. The present absence of HRF editorial and other literatures will probably end shortly as two HRF's will be created in 2011 in Federal Emergency Management Agency (FEMA) Regions X and V.

## **E. HYPOTHESES**

America's elected officials and public will have expectations of effectiveness from the HRF. By paying heed to DoD's preceding response organizations and by carefully selecting a combination of civilian and military response standards and practices, the regional HRF can more effectively support America's responders.

Following disasters, political leaders, and the public often demand inquiries into perceived deficiencies. Additionally, federal and DoD agencies are periodically examined for fiscal responsibility and effectiveness. With the selection of proper standards for training and oversight, the HRF can better meet the demands of routine or post-incident inquiry. The HRF is preceded by four other DoD all-hazard and or CBRNE response units. Two of these units, the DoD's active-component CBRNE Consequence Management Response Force and the National Guard's Civil Support Teams (CST) have been subjected to DoD and Government Accountability Office (GAO) audits resulting in many negative remarks that required corrective actions (GAO 2006; 2009). Following the 2006 Second Lebanon War, the Israeli Defense Force's (IDF) Home Front Command (HFC) also received critical comments in report from Israel's civilian Winograd Commission. This precedence of audits indicates the HRF program should select sound standards and response practices to avoid future audit related criticisms and corrective actions.

The HRF's hybrid civil-military and regional mission presents new challenges and opportunities for DoD to support America's communities and responders. With a large annual budget, many personnel, and extensive response capabilities, the HRF must have carefully selected standards for future development. Audits critical of DoD's older domestic response organizations reinforce a need for clear standards.

## **F. METHODOLOGY**

This thesis will employ a qualitative research method using case studies of DoD's existing CBRNE organizations and the IDF's HFC to draw conclusions that might be relevant to creating the new HRF. Audits and articles found in defense journals and open media regarding CBRNE and all-hazards response organizations provide the basis for a case study that can identify past patterns and policies of inherent importance to the HRF. As mentioned in the literature review, GAO and DoD audits provide statistics and insights regarding the strengths and shortcomings of the CST and the CCMRF. A review of the critical and positive comments found in past GAO and DoD audits of DoD's CBRNE capabilities can identify practices the HRF might adopt or avoid. The fact that

the HRF is required to respond in concert with DoD's existing CBRNE and all-hazards response units also makes a case study method applicable to its development.

## **G. HOMELAND RESPONSE FORCE BACKGROUND INFORMATION**

The HRF reflects an evolution in U.S. military units with CBRNE and disaster related homeland security missions that stem from Presidential Decision Directives and legislation in the 1990s. Created in 1996, the Marine's 350-person Chemical Biological Incident Response Force (CBIRF) was the first military CBRNE unit with a domestic CBRNE response mission. In 1998, Congress created the National Guard Civil Support Teams (CSTs) to identify CBRNE agents, provide communications, and advise civilian officials. To increase CBRNE capabilities and provide decontamination, medical treatment, and SAR, the National Guard created CBRNE Enhanced Response Force Packages (CERFPs) in 2003. In 2007, the DoD established a fully-staffed "active duty" or federal Consequence Management Response Force (CCMRF) with 5200 personnel to provide a DoD CBRNE response to a larger national CBRNE incident. The CCMRF was restructured in 2010 and renamed as the Defense Consequence Management Response Force (DCRF) and controlled by the President, the DCRF represents a federal military response to large CBRNE incidents (Coble, 2011).

Despite a decade of evolving CBRNE capabilities that addressed state and large federal disasters, a regional response gap existed. The Columbia space shuttle disaster and Hurricane Katrina demonstrated the need for a regional CBRNE and disaster response capability. Both incidents occurred across entire FEMA regions, required advanced communications and interagency coordination and employed up to 22 of the state-level CSTs. A 2007 article, titled *Brigade Headquarters for National Guard Civil Support teams: a Homeland Security Imperative*, by Lieutenant Colonel James Campbell reflected the need for greater control of CSTs and CBRNE elements response across FEMA regions (2007).

Proposed by the OSD for implementation, the HRF was selected from several National Guard and active military alternatives in 2009 to fill a regional CBRNE capability between state and federal level responses. (See Figure 2). Existing CBRNE

units presently meet state and large national CBRNE incidents. As part of a comprehensive CBRNE capability known within DoD as the “CBRN enterprise,” the National Guard will maintain an existing force structure of 57 Weapon of Mass Destruction Civil Support Teams (WMD-CSTs or CSTs) and 17 CBRNE Enhanced Response for Packages (CERFPs) in addition to the 10 new HRFs filled by 10,000 soldiers and airmen.

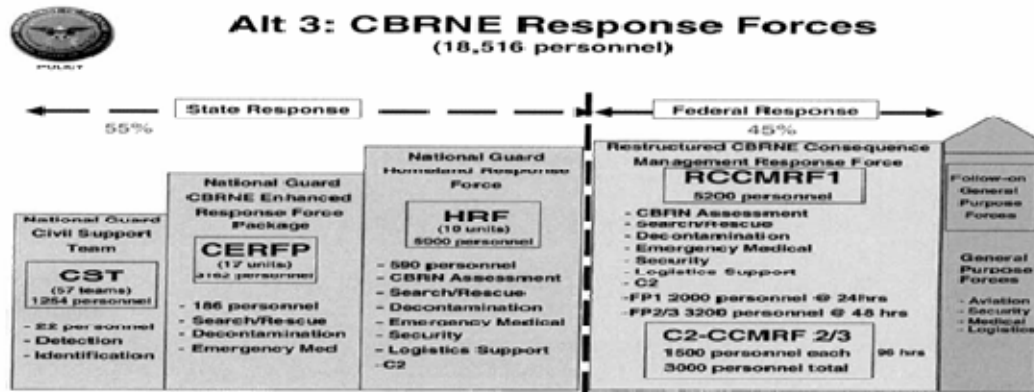

Figure 1: OSD Policy Hybrid Alternative

Figure 2. OSD Policy Hybrid Alternative (From Office of the Secretary of Defense, 2009)

Residing within a FEMA region, the HRF will serve as the command and control (C2) headquarters for CSTs, CERFPs, and conventional military units providing support through Emergency Management Assistance Compacts (EMAC) to a regional CBRNE incident or disaster. Figure 2 depicts the structure and concept of a Georgia-based HRF and the existing CSTs and CERFPs within FEMA Region IV. As part of the OSD directive, the National Guard must transform 10 existing “brigade” sized units into the HRFs by the year 2014 (M. Reese, personal communication, December 18, 2009). OSD has stipulated that two HRFs be fully mission-capable by October 1, 2011 (M. Reese, personal communication, December 18, 2009).

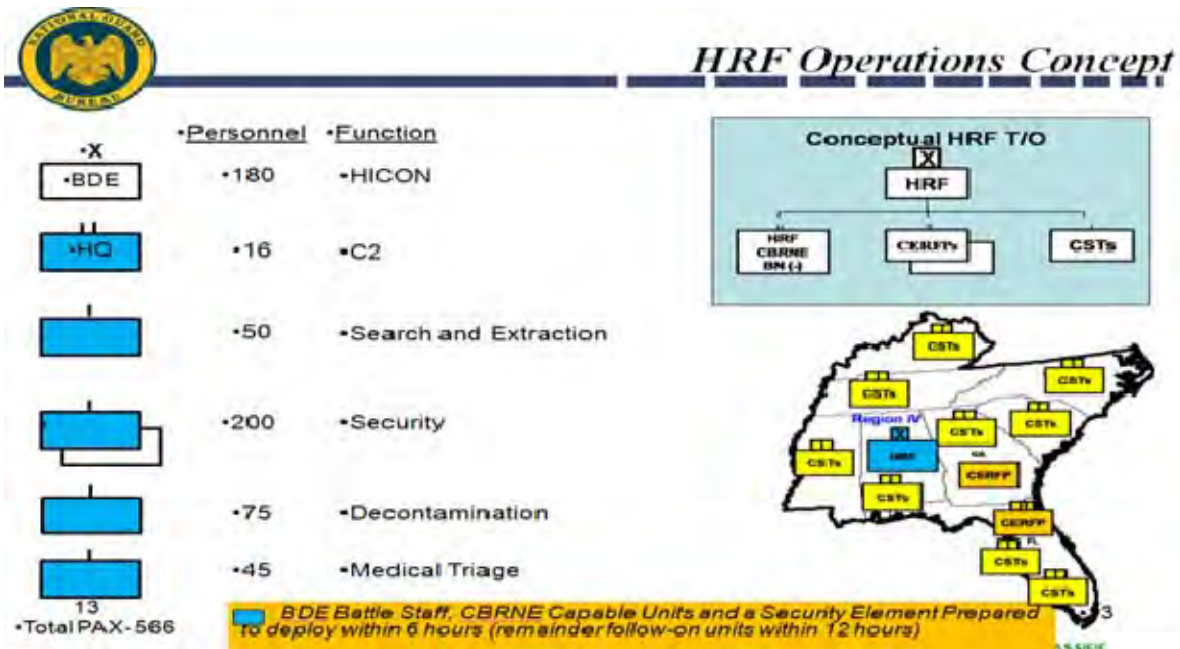

Figure 3. HRF Structure and Operational Concept (From National Guard Bureau 2009)

Prior to the HRF, all of DoD’s homeland security organizations experienced significant setbacks and controversy from within and outside the government. Two of DoD’s existing CBRNE organizations have experienced GAO audits. In 2000, the Army’s Inspector General recommended elimination of the CST program based on poor training, doctrine, and flawed equipment (Lieberman, 2001). With little to contribute to direct combat operations in Afghanistan and Iraq, some Marine leaders questioned the need for the CBIRF. In 2004, the active Army blocked the development of the Guard’s CERFP equipment, training, and organization (Jones, 2004). An October 2009 GAO audit of the CCMRF indicated shortcomings in regional response, funding, and training demands (GAO, 2009). The ACLU and other civil liberties organizations questioned the first ever assignment of federal military forces under NORTHCOM for a domestic response incident (ACLU, 2008). This precedence illustrates the challenges, oversight and controversy the HRF will face.

THIS PAGE INTENTIONALLY LEFT BLANK

## **II. PREVIOUS DOD CBRNE AND ALL-HAZARDS RESPONSE ORGANIZATIONS**

The HRF is preceded by several DoD CBNRE organizations that provide examples of implementation successes and setbacks as well as mission “scoping” that the HRF can follow. A common theme for these organizations is the conflicts that can arise when deploying U.S. military forces domestically. Military organizations, culture, equipment, and personnel have traditionally followed different guidelines than civilian organizations. American military organizations tend to deploy outside the U.S., where they follow doctrine and the Geneva Conventions instead of OSHA, EPA, and other standards for environmental response and civilian work place protection. Though rugged, military equipment is not always designed to complement civilian response measures and might only provide “survival” levels of protection. Much of the military’s CBRNE protective clothing and detection equipment was developed to meet Cold War battlefield-level detection that might be measured with alarms and bars and not the part-per-million (PPM) or REMs used by civilian responders. America’s civil liberty laws, federal authorities, state authorities, and intelligence oversight laws also provide sharp areas of contention for domestic military employment. Regarding domestic CBRNE units, some military leaders have stated that DoD should mainly focus on overseas missions and let response agencies such as FEMA or the EPA handle homeland security-related missions. Leadership from civilian agencies charged with statutory response roles also question the need for dedicated military CBRNE and homeland security forces when civilian agencies already fill those roles. Previous DoD CBRNE organizations have encountered public criticisms, but they have also had some notable response successes and the HRF can benefit from the experiences of these organizations.

In the 1990s, new presidential directives and legislative actions specified that the U.S. military support domestic response to CBRNE incidents. The CBIRF and the WMD CST program (CST Program) originated from the 1995 Presidential Decision Directive (PDD) 39, Counter-terrorism Policy, the 1996 Nunn Lugar Domenici Act, *Defense Against Weapons of Mass Destruction Act* and, more specifically, the 1998 PDD 62,



*Protection Against Unconventional Threats to the Homeland and Americans Overseas* (Congressional Record 1996, White House, 1995; 1998a). These directives provided a broad framework for a national-level response that integrates military forces for potential CBRNE response and homeland security missions. The PDDs and the resulting creation of the Marine Corps' Chemical Biological Incident Response Force (CBIRF) and Civil Support Teams were steps in a strategy to offset acknowledged gaps in the nation's capabilities to respond to CBRNE use against the United States and its territories.

**A. THE CHEMICAL BIOLOGICAL INCIDENT RESPONSE FORCE**

Created in 1996, the Marine's 350-person CBIRF was the nation's first military CBRNE unit with a partially-domestic CBRNE response mission. Within CBIRF, the Marines created the first true CBRNE task force with decontamination, analytical, search and rescue (SAR), medical, explosive ordinance detachment (EOD), CBRNE detection, and security element. Located at Indian Head, Maryland, the CBIRF is "dual-missioned" with both domestic and overseas CBRNE mission requirements. With advanced civilian-equivalent hazardous materials (HAZMAT) training and equipment, the CBIRF has deployed to multiple national special security events (NSSE) and CBRNE-related incidents. These include Olympic Games, the 2001 anthrax attack at the Hart Senate building, the 2004 Dirksen Senate Office Building ricin letters, and a clandestine CBRNE laboratory in Fallujah, Iraq in 2004. (CBIRF, 2004)



Figure 4. CBIRF Task Organization (From CBIRF, 2008)

Located close to the Nation Capital Region (NCR), the CBIRF is considered essential to any CBRNE or other significant hazard that might impact the capital region. Aligned closely with protecting the nation's capital and federal-level response missions, the CBIRF and its suite of resources might be *underutilized* for both its domestic and overseas missions. Consequently, outside of federal properties the CBIRF has had few local, state, or natural disaster responses due to its federal status and unique NCR mission. Despite its status as the original CBRNE task force with a central domestic mission, CBIRF has escaped the oversight questions and controversies that have hampered other CBRNE elements. With extensive capabilities and demonstrated performance, the CBIRF has become the basis of comparison for all other military CBRNE organizations (S. Pitts, personal communication, March 9, 2011).

## **B. THE CIVIL SUPPORT TEAM**

The National Guard's CSTs, formally known as Weapons of Mass Destruction Civil Support Teams, were announced by President Clinton at the May 1998 Naval Academy graduation ceremony as a program created to meet the growing threat of terrorist use of CBRNE. The CSTs were originally designated rapid assessment and initial detection (RAID) teams but the name was changed to better reflect a civil support role and for a less aggressive title as a domestic military organization. By June of 1999, the first 10 of a total of 57 future CSTs were fully staffed, equipped, and training for the CBRNE incidents that soon impacted America. The 57 CSTs employ 22 active-duty National Guard personnel to identify CBRNE agents, provide communications, and advise civilian officials. Designed to deploy within 90 minutes to the immediate needs of Local, state, or federal agencies, the CSTs are a state-level military organization that does not fall under Posse Comitatus. Unlike all other DoD CBRNE organizations and the HRF, the CST program is a statutorily-based program directed to exist by following language in PPD 62:

The Department of Defense, in coordination with other Federal Departments and agencies, will provide training to metropolitan first responders and will maintain trained military units to assist State and local responders. One example is the National Guard concept of initially forming 10 Rapid Assessment and Initial Detection (RAID) teams in each

FEMA Region. These teams are designed to provide rapid response to a WMD incident and assist State and local responders. (White House, 1998a)

The language of PPD-62 makes the CSTs unique since DoD's other CBRNE organizations can be eliminated through budget cuts. Additionally the CST is the only CBRNE element with an exclusively domestic CBRNE response mission. DoD's other CBRNE units are dual missioned with both overseas and domestic missions. The CSTs are restricted by law to remain in the US and its territories for response operations whereas all other CBRNE elements might be deployed overseas when a domestic disaster occurs. Furthermore, the CSTs follow an Incident Command System (ICS) based structure and develop ICS-based documents such as the Incident Action Plan and Site Safety Plan used by civilian response agencies at all levels.

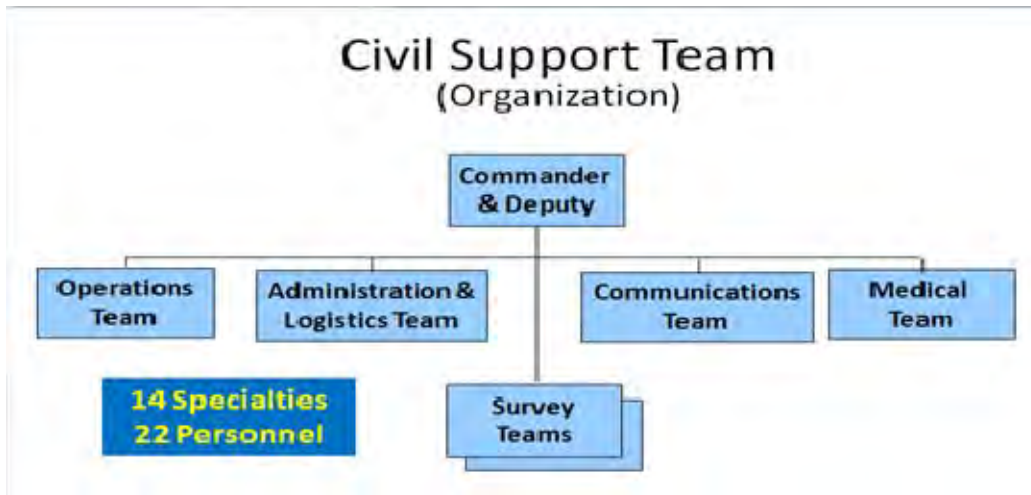

Figure 5. Civil Support Team (From Hudoba & Reese, 2007)

The CST program began with a narrow scope of CBRNE response missions. Designed to work for civilian authorities at the local, state, and federal levels while meeting all civilian hazardous materials (HAZMAT) response standards, the first 10 CSTs were distributed to each FEMA region. Subsequent CSTs were distributed to three states and the territories of Guam, Puerto Rico, and the Virgin Islands. In addition, Florida, California, and New York are the states that received two CSTs. The methodology of creating a military unit with civilian interoperability proved challenging

but invaluable. Able to integrate fully with a civilian response; CSTs are adept at bringing DoD laboratories, training, and resources to bear during large scale incidents.

The CST's mission statement reads as:

Support civil authorities at a domestic chemical, biological, radiological, nuclear, and high-explosive (CBRNE) incident site by identifying CBRNE agents/substances, assessing current and projected consequences, advising on response measures, and assisting with appropriate requests for state and federal support. (National Guard Bureau, 2007)

The unique nature and the untested methods of state-level CSTs brought problems and harsh review in late 2000. Large monetary and personnel resources were expended in training and equipment for the new mission. The CSTs were provided advanced analytical technologies such as portable gas chromatograph mass spectrum (GCMS) and polymerase chain reaction (PCR) analytical devices. Previously used in fixed laboratories, these cutting edge technologies were fielded to the CST for response operations without significant DoD testing. A scathing January 2001 report by the DoD Inspector General report derided the CST program as an extravagant waste of personnel and resources on a poorly developed concept (DoD Inspector General, 2001). In the book *Germes* (2001), author Judith Miller criticized the CST program and claimed that it should have ended during the Clinton administration (Miller et al., 2001) These criticisms soon subsided.

CST successes in New York on September 11, 2001, and in hundreds of subsequent responses prompted by anthrax and ricin events brought credit to the new program. Initially criticized as expensive, the CST program served as a platform for equipment and technology spin-offs that have subsequently benefitted FEMA, U.S. Northern Command, the EPA, local fire departments, and other agencies. Additionally, it was generally recognized that the federally funded, state-level CSTs brought DoD's first response along with expensive advanced technologies not often found at local levels or matched by federal military CBRNE elements.

Containing robust communications, scientific analytical systems, and medical capabilities the CSTs were designed to respond to CBRNE threats. Yet the CSTs suffered the short coming of *too narrow* of a mission scope. The CST's communications and

laboratory capabilities at an incident can *exceed the* organization's original CBRNE response mission assets. In addition to CBRNE events, the CSTs were frequently employed for regional-level responses such as the space shuttle disaster, Hurricane Katrina, Hurricane Gustav, and wild fires. The CST's advanced mobile communication vehicle, the Unified Command Suite (UCS), provided invaluable secured communications capability essential to command and control and a common operating picture (COP) of local and regional incidents. At "ground zero" the New York National Guard's second CST proved invaluable by providing HAZMAT assessments and Secure Internet Protocol Router (SIPR) classified communications for the FBI and other agencies. The non-CBRNE nature of some of these all-hazards missions actually violated the CST's congressionally directed mission. A 2006 GAO audit found high levels of readiness in the CST program but also identified confusion over the CST's increasing role in disaster response missions (GAO, 2006). Following the deployment of elements of 22 CSTs to Hurricane Katrina, Congress changed the CST mission, including all-hazards missions, as part of the *John Warner National Defense Authorization Act for Fiscal Year 2007* (National Defense Authorization Act, 2007).

During response events such as the anthrax attacks, multiple NSSEs, and natural disasters, the CSTs have proven their ability to assess hazards, provide communications, and speed recovery from attacks and natural disasters. Extensive individual, collective training, and frequent external evaluations conducted by U.S. Army North contributed to these successes. The performance measures used to train and evaluate CSTs were developed using National Fire Protection Agency, EPA, OSHA, and DoD standards for HAZMAT and CBRNE response. CST personnel attend hundreds of hours of HAZMAT training and additional training based on specific duties. Even so, gaps still existed in training and proficiency with the CST advanced CBRNE detection and analytical capabilities. Better performance measures were eventually developed by the CSTs themselves, the program's interagency Civil Support Team Work Group (CSTWG). To better meet CDC requirements, the CSTs adopted the International Organization for Standardization 17025 laboratory standards for the CST's mobile CBRNE Analytical Lab Suite (ALS). The internal implementation of Proficiency Analytical Testing (PAT) of

CBRNE equipment and increased laboratory standards reflect performance measure gaps that were identified and addressed internally by the CSTWG and National Guard Bureau rather than an external agency like the GAO (B. Webb, personal communication, August 18, 2009).

Supported by the President and Congress, the CSTs were well implemented despite initial criticisms. The teams have filled WMD and all-hazards response gaps at the state and local levels while surging for larger regional events. The utility of the CST program to respond to national needs is evident in thousands of missions over an 11-year period. Thru the CSTWG, the CSTs and National Guard Bureau internally directed changes to improve CBRNE-related analytical and laboratory procedures to address gaps that were not addressed by legislation, PPDs, or the GAO. The initially narrow CBRNE mission of the CSTs was broadened by Congress to accommodate natural disaster missions. In the words of a Coast Guard Commander of an all-hazards response unit, “The CST’s employment of ICS and advanced training and equipment make them popular and viable in events like Katrina, Ike, Gustav and the New Horizon Oil Spill” (V. Kammer, personal communication, November 8, 2010). Combining military resources at a state level with the civilian incident command system (ICS) response model, equipment, and training increased CST accessibility and interoperability with responders at all levels of government. To date, the CST’s combination of advanced communications, laboratory, and technical capabilities relating to domestic CBRNE and all-hazards incidents remain unmatched anywhere in DoD.

### **C. THE CBRNE ENHANCED RESPONSE FORCE PACKAGE**

The National Guard created 12 CBRNE Enhanced Response Force Packages (CERFPs) out of traditional part-time Army National Guard and Air National Guard units in 2003 as a follow-on force to the CSTs and to emulate some of the capabilities found in CBIRF. Established by the Director of the National Guard, Lieutenant General Stephen Blum, the CERFPs represent the first use of conventional engineer, chemical, and

medical units to provide a “task force” of SAR, security, decontamination and medical treatment capabilities within six to 12 hours of a domestic CBRNE or all-hazards incident with the following mission statement:

On order, respond to a CBRNE incident and assist local, state, and federal agencies in conducting consequence management by providing capabilities to conduct personnel decontamination, emergency medical services, and casualty search and extraction. (National Guard Bureau, 2007)

According to Malchholm Reese of the National Guard Bureau, who is widely considered a key founder of the CERFP program, “prior the HRF, the CERFPs were intended to serve as a bridging capability between state and federal response resources for large disasters” (M. Reese, personal communication, December 19, 2010). In 2006, another five CERFPs were added for a total of 17 CERFPs. Distributed across the 10 FEMA regions, the 186-person CERFPs leverage the CST’s existing detection, analytical, and communications capabilities to help manage the consequence of a local, state, or regional-level CBRNE event or disaster.

Intended to place minimum training and equipment impacts upon dual-missioned conventional units, the CERFPs are lightly equipped with civilian personal protective equipment (PPE) and predominately hand-held SAR and CBRNE equipment. The CERFP’s Air National Guard medical organization mission remained essentially unchanged in both its overseas and domestic missions. With a goal of readiness for domestic CBRNE incidents without diminishing a unit’s training for overseas missions, the CERFP unit was provided an additional two weeks of training time and provided additional full-time staff members intended to assist and train the predominantly part-time National Guard soldiers on their CBRNE mission. The CERFP’s organization and mission information follows (Figure 6):



Figure 6. CERFP Organization (From Hudoba & Reese, 2007)

Unlike the congressionally-directed CST program, the CERFPs started as a “pilot program” exclusive to the National Guard that came without external support or funding from DoD. Initially the units assigned to CERFP duties did not have access to funds to pay for daily CBRNE equipment maintenance, nor did they exist as a formally budgeted and authorized DoD program of record. A lack of formal DoD recognition for the CERFP proved an initial drawback.

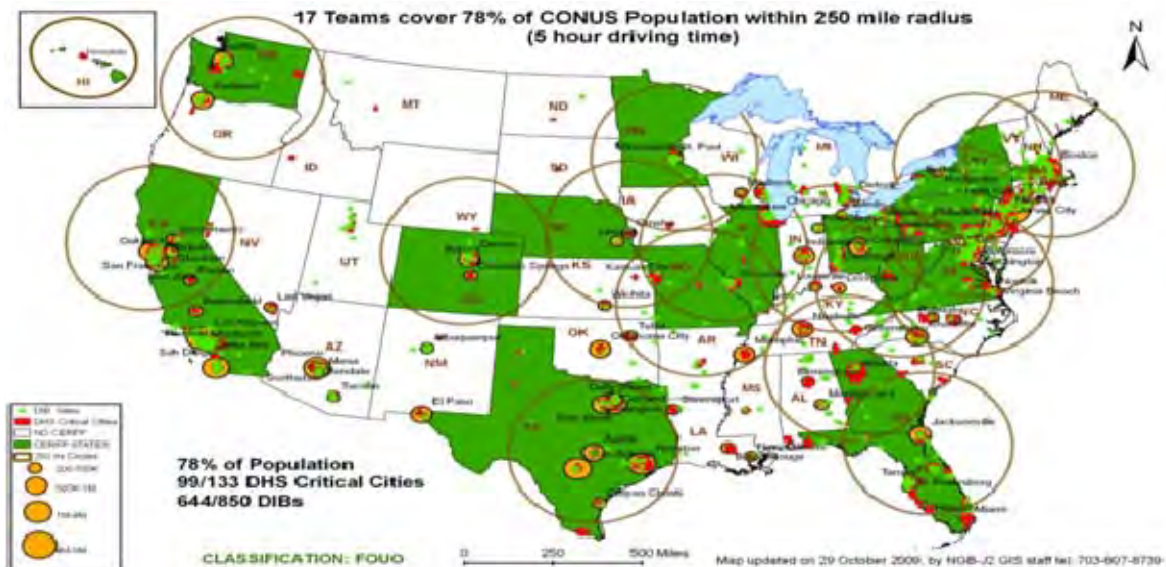

Figure 7. CERFP Team National Coverage (From Hudoba & Reese, 2007)



In 2004, the Army blocked the funding, equipment and doctrinal support for the National Guard's CERFPs. With some justification, Army leaders cited that requisite resources from DoD were not provided for CERFPs. A May 2004, U.S. Army Training and Doctrine Command (TRADOC) letter from Lieutenant General Jones clearly stated that no development or support for the CERFP would come from the Army's TRADOC. Paragraphs from the 2004 TRADOC letter raised questions, still unanswered, regarding dual-missioned domestic CBRNE military roles:

4. The proposed creation of a task organized first responder capabilities drawn from warfighting units has potential ramifications for both the Army and Regional Combatant Commanders for which these forces may be apportioned. This type of dual missioning is a growing concern as we work to delineate the Army's roles and responsibilities in support of Homeland Security operations.

5. First responder programs are under the purview of the Department of Homeland Security, Office of Domestic Preparedness. In the context presented, the CERFP is just such a program. The utility of expending critical Army resources in support of a non-Department of Defense or Army mission will be weighed accordingly. (U.S. Army TRADOC, 2004)

Heated debates ensued over the interpretations of the National Guard's CERFP initiative and 2004 TRADOC letter until finality in guidance on the CERFP program came from Congress.

By 2006 Congressional leaders determined the CERFPs were essential and the pilot program became a funded program of record. Both in authorization and appropriation the language from the *2006 National Defense Authorization Act* reflects this transition:

The committee recommends an increase of 19.8 million for this (CERFP) program. Of that amount the committee recommends an increase of 9.5 million to establish five additional NG CERFP teams and an increase of 10.3 million dollars to provide sustainment funding for the 12 existing NG CERFP teams. The NG CERFP pilot program was initiated in fiscal year 2004 and has proven to be a valuable asset for federal and state authorities. (National Defense Authorization Act, 2005)

As in the creation of the CST program, Congressional action provided specific guidance on budgeting and provided additional full-time CERFP staff. These actions

eliminated many of the internal DoD obstacles to funding and equipment issues that had pestered the CERFP program. Further support for the CERFP came in an August 17, 2006 Joint Requirement Oversight Council (JROC) memorandum signed by Admiral Giambastiani. DoD's Joint Staff recognized the CERFP program and directed detailed doctrine, organization, training, equipment, and DoD support for the program (DoD Joint Staff, 2006). By 2008, the CERFP program had become a fully vested DoD program under the purview of the Army National Guard.

Lieutenant General Blum's internal program funding and the National Guard's original use of dual missioned forces for CBRNE roles caused initial setbacks for the CERFPs. Still the concept and the inception of the CERFP demonstrated the application of lessons learned from the CST program, CBIRF, and Israel's use of military forces in its Home Front Command (HFC). DoD, CST, and civilian response personnel helped develop the CERFP's concept of operations (CONOPS), training, equipment, and organization. Initially operating with limited funding, the CERFPs employed equipment, logistics, and acquisition methods established by the CST. The U.S. Army North validated CERFP readiness during major national level exercises (NLE) exercises. A cross section of the CERFP's founders include Lieutenant Colonel Harold Molbert, who reflected on some of the positive lessons that the CST program derived from the negative 2000 DoD IG Audit—"The 2000 DoD IG audit of the CSTs provided a valuable lesson—we wanted to establish clear cut and unassailable standards for the CERFP that avoid undue and unproductive criticisms" (H. Molbert, personal communication, July 20, 2005).

Congressional support proved decisive to the success of the CERFP program. The CERFPs have had many successful missions and are demanded for NSSE's and state-level events. CERFP NSSE support includes the 2008 Republican and Democratic National Conventions and the deployment of four CERFPs for the 2009 Presidential Inauguration. While portions of CERFPs deployed to Hurricane Katrina, other CERFPs supported the response to a 2010 Tsunami in American Samoa and a 2007 Jacksonville, Florida parking garage collapse (M. Ladd, personal communication, February 15, 2011). The deployment of elements of the Florida CERFP to the 2010 New Horizon Oil Spill

stands out as a *critical* CERFP deployment, which again demonstrates the utility that organizations originally designed for CBRNE use can provide. To date, the CERFPs have not responded to an Oklahoma City-type bombing event or a large earthquake. In either scenario, the National Guard’s 17 CERFPs, with some 3100 personnel dispersed across the U.S., are now postured to bring lifesaving SAR, decontamination, and medical care to American citizens.

**D. THE CBRNE CONSEQUENCE MANAGEMENT RESPONSE FORCE**

In 2007, the DoD established a fully-staffed Consequence Management Response Force (CCMRF) with 5200 personnel to provide a larger joint DoD CBRNE and all-hazards response capability to large or multiple disasters. Despite the CBIRF, CST, and CERFP successes, the CCMRF was created to bring larger scale federal military capabilities to larger CBRNE incidents. Integrating the Marines’ CBIRF as its central CBRNE element along with conventional battlefield military forces, the dual-missioned CCMRF also contained dedicated aviation assets, mortuary support, and mapping capabilities from conventional forces. Operationally controlled by the U.S. Northern Command (NORTHCOM) and its subsidiary land component command, U.S. Army North, the CCMRF represented the first large domestic military force intended for deployment on U.S. soil since the Civil War.

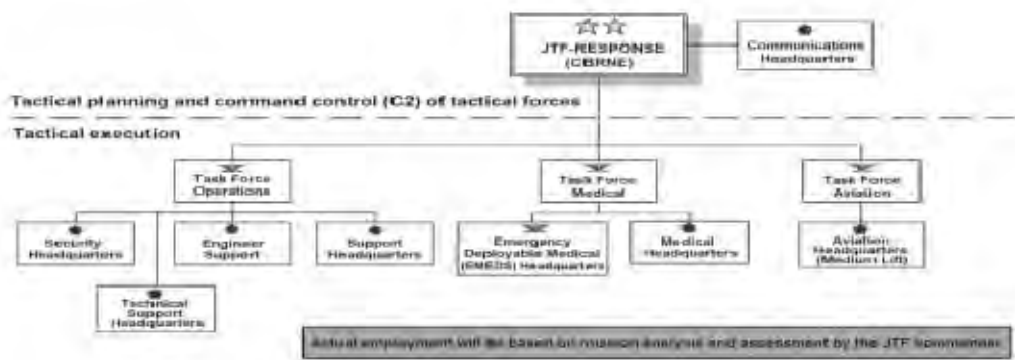

Figure 8. CCMRF Structure (From Anderson, 2009)

Falling under a U.S. Army North headquarters named Joint Task Force Civil Support; the CCMRF contained a Task Force Operations, Task Force Medical, and a Task Force Aviation. The Marine CBIRF is integrated into the Task Force Operations. DoD originally intended that an initial CCMRF be followed by two more CCMRFs, comprised mainly of National Guard and U.S. Army Reserve elements. This reflected a DoD goal of responding to simultaneous domestic incidents with additional CCMRFs filled by state-level military forces working for the President in an activated federal status.

The 1<sup>st</sup> Brigade Combat Team (BCT) from Third Infantry Division at Fort Stewart, Georgia was the first federal conventional military element to comprise the first CCMRF. This Army BCT was intended to fill the CCMRF mission for a year between deployments to Iraq. Like the CBIRF, other CCMRF assets were pulled from across DoD to fill the CCMRF. These included Air Force engineer units, Navy weather teams, and members of the Defense Logistics Agency. Training active duty soldiers, typically employed in counter-insurgency operations, to meet domestic operations requirements between deployments provided challenges. The first full-scale CCMRF rehearsal exercise was conducted at Fort Stewart, Georgia in October 2008. The exercise demonstrated the challenges of pulling organizations together from across all of DoD for a domestic response mission between overseas deployments. CCMRF members practiced decontamination, SAR, medical, security operations, and crowd control during a large scale domestic scenario. Military combat engineer units practiced debris removal tasks.

The CCMRF concept and mission demonstrates valid concerns and some contradictions in employing federal forces within the U.S. Despite the use of federal and state military forces at the 1992 Los Angeles Riots and during the Civil Rights era, the CCMRF evoked strong reactions from both liberal and conservative elements. An October 2008, *Army Times* interview with the Colonel Roger Cloutier, the commander of the CCMRF's conventional combat forces best illustrates the dilemmas found in employing the military for homeland security missions:

The 1st BCT's soldiers also will learn how to use "the first ever nonlethal package that the Army has fielded," 1st BCT commander Col. Roger Cloutier said, referring to crowd and traffic control equipment and nonlethal weapons designed to subdue unruly or dangerous individuals without killing them, "It's a new modular package of nonlethal capabilities that they're fielding. They've been using pieces of it in Iraq, but this is the first time that these modules were consolidated and this package fielded, and because of this mission we're undertaking we were the first to get it." (Cavallaro, 2008)

Colonel Cloutier's comments resulted in an uproar and brought about expressions of concern from the American Civil Liberties Union (ACLU) (Christensen, 2008). Conservative media had an equally negative response to the comments and the CCMRF mission. Both ends of the political spectrum felt the CCMRF encroached too closely on Posse Comitatus Act and disliked that an organized military force stood ready under NORTHCOM for domestic missions.

An October 2009 GAO audit of the CCMRF dealt a further blow to the CCMRF mission. The audit reflected many of the CCMRF challenges. The GAO audit questioned whether a centrally located CCMRF could respond nationwide in time to positively impact a crisis (GAO, 2009). The GAO also found that the training and rotation demands of Iraq and Afghanistan impeded the availability of active duty forces for the CCMRF. Units originally assigned to the CCMRF for a year were quickly pulled from the CCMRF to support overseas missions. The GAO audit also found confusion over appropriate doctrine, training, and funding (GAO, 2009). The CCMRF's poor linkage to existed civilian agency plans was also noted. Shortly thereafter, the Army's TRADOC issued an October 23, 2009, "cease work" order on the CCMRF partially because of GAO audits findings and emerging domestic CBRNE response force structures (TRADOC, 2009).

The CCMRF represented the most contentious of all of DoD's CBRNE units and faced all of the difficulties that detracted from the CST and CERFP programs and which were seemingly amplified by the organization's larger size. Beyond routine funding, equipping, and training problems recognized by the GAO, the CCMRF raised Posse Comitatus and civil liberties concerns at many levels of government and by political interests. In late 2009, the Secretary of Defense announced the creation of 10 National

Guard HRF units over the recommendations of NORTHCOM’s commander, General Victor “Gene” Renuart for a continuance of three federal level CCMRFs and a reduction in state-level CERFPs (Office of the Secretary of Defense, 2009). In 2010, the CCMRF was restructured and renamed the Defense CBRNE Response Force (DCRF) and the two follow-on CCMRFs were dropped for smaller general purpose support elements. The original concept of three large CCMRFs acting as a strong federal force for domestic missions had ceased in November 2009 in favor of a new balance of 55 percent state and 45 percent federal forces in “CBRN Enterprise” (Figure 9) that includes the regionally based state HRF concept.

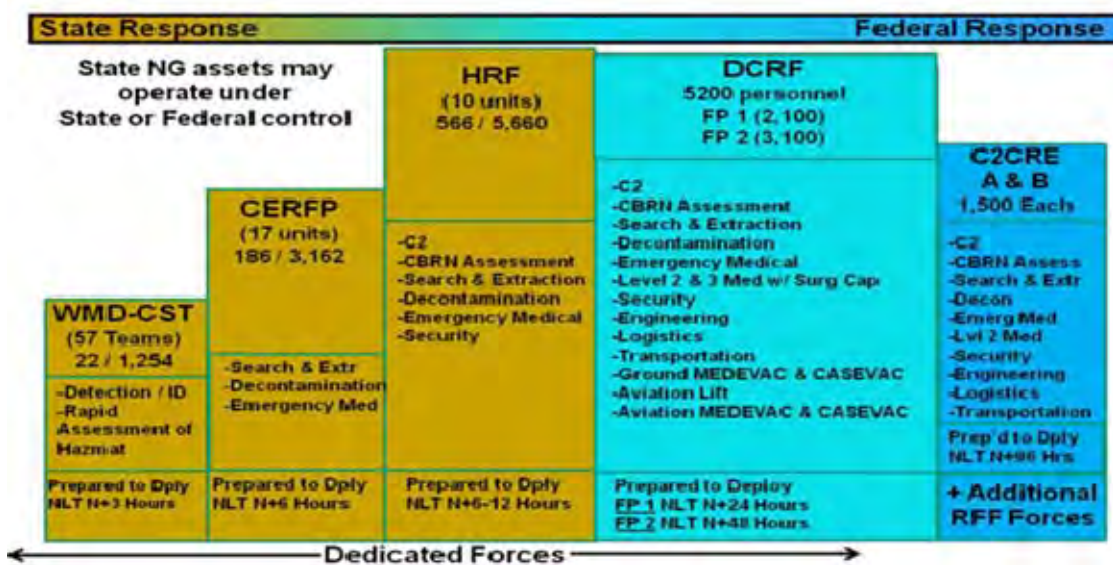

Figure 9. The CBRN Enterprise (From National Guard Bureau & U.S. NORTCOM, 2011)

### E. LESSONS FROM PREVIOUS CBRNE ORGANIZATIONS

Congressional and Presidential action during the 1990s and the subsequent decade thrust DoD into a more specified domestic role than it had known before. The Marine’s CBIRF and the National Guard CSTs represent a “ground-shifting” evolution in military support to civil authorities with critically valuable equipment and training spin-offs based on these actions. When the National Guard and active-duty Army components had different views on the CERFP’s dual-missioned use of military forces for domestic missions, Congress again took a lead by funding and expanding the CERFP programs. Despite negative audits and reports of CBRNE units, the National Guard’s CBRNE

dedicated CSTs and dual-missioned CERFPs have demonstrated accessibility and utility as response units at state and regional-sized incidents. Although the Marine Corp's excellent federal-level dual-missioned CBIRF has remained unequivocally beyond criticism, the larger federal and dual-missioned CCMRF received harsh approbation from many quarters.

The HRF must integrate the valuable lessons learned from the CBIRF, CSTs, CERFPs, and CCMRF. The state level CSTs and CERFPs represent an asset that governors can employ rapidly to the majority of America's disasters without the civil liberty concerns so detrimental to the CCMRF. The CCMRF mission demonstrates contradictions in U.S. domestic military operations. During the 1992 Los Angeles Riots, both federal and National Guard components used deadly force to confront violent mob activities with little repercussion. Armed federal and state forces were welcomed during Hurricane Katrina. But the original aggressive "RAID" title for the CSTs and the 2008 comments by the CCMRF commander raised civil liberties concerns. The prospects and discussion of DoD organizations conducting riot control-type activities evoke negative civil liberties issues. Despite some negative publicity, in responses such as the anthrax attacks, Katrina, and the New Horizon Oil Spill, the CBIRF, CST, and CERFP organizations have become popular while demonstrating effectiveness in both CBRNE and all-hazards responses.

The CST model indicates that with the integration of advanced civilian training, advanced technologies, and with a ICS based structure the HRF might enjoy greater utility and interoperability with civilian response organizations. The use of CERFPs and CSTs at the New Horizon Oil Spill, the 2003 space shuttle response, and other non-CBRNE disasters might indicate that the HRF should look to broad all-hazards missions with the capability to share classified information across large areas in addition to a CBRNE role. Pursuing a dedicated domestic CBRNE and all-hazards response organization, versus a dual-missioned organization, could help the HRF avoid some of the civilian and TRADOC concerns raised by forces trying to combine the conflicting laws and practices of overseas combat and domestic missions. The CST's advanced analytical laboratory and CBRNE detection and communications equipment have ensured

great utility beyond the CST's original mission. Internally, the CSTWG helped National Guard Bureau refine the training and employment of these resources. When an HRF has to control multiple CSTs and CERFPs during a significant regional disaster, the coordination of laboratory, CBRNE survey results, and communications capabilities on a larger scale will be *essential* to providing region-wide incident awareness and assessment, and a COP to the HRF's parent and subordinate units.

Based on the initial criticisms and the eventual successes of the CST's often experimental technologies, the HRF should seek advanced systems that will provide the best "network-centric" response possible to link communications, CBRNE detection capabilities, and existing DoD and civilian communications assets during a regional level response. The need to provide classified communications and "network centric" capabilities will push the HRF closer to intelligence related roles that present civil liberty concerns. Based on previous experience by a DoD domestic CBRNE element the HRF *should* avoid expressed training and planning for nonlethal crowd control operations.



THIS PAGE INTENTIONALLY LEFT BLANK

### **III. CIVILIAN AND MILITARY LAWS AND PRACTICES FOR THE HRF**

This chapter highlights a potential gap in the development of the HRF and the associated DoD CBRN enterprise with existing domestic CBRNE and hazardous materials response practices and laws. It also recommends that civilian CBRNE and response standards, such as the National Oil and Hazardous Substances Pollution Contingency Plan (NCP), the National Response Framework (NRF), and the National Incident Management System (NIMS), should take precedence over military operational doctrine and contingency plans (CONPLAN) for the employment of the HRF. Civilian standards can provide a foundation for HRF's successful implementation, enhanced interoperability, and avoid future legal and operational setbacks. Criticisms of previous DoD CBRNE responses in government audits and private reports include: wasted tax dollars, poor training strategies, and poor links to the plans of civilian agencies. Adaptation of civilian standards, intelligence oversight, and military "incident awareness and assessment" (IAA) practices during implementation could help the HRF avoid past criticisms while filling a regional CBRNE response mission.

Sound integration with existing statutory response organizations and guidelines can help the HRF operate safely and effectively with other response organizations. All of DoD's past domestic CBRNE organizations have faced intense scrutiny or setbacks. The hybrid "civil-military" nature of these organizations presents some of these problems. They must meet two sets of standards: DoD standards and civilian emergency response requirements. Military organizations conducting overseas or "*homeland defense*" missions follow DoD doctrine and mainly operate outside of U.S. tort law and federal regulations. Conducting CBRNE and disaster response domestically in "*homeland security*" missions, the HRF must follow both DoD and civilian emergency response requirements.

## A. PPD-8 AND PLANNING GUIDELINES

The Presidential Policy Directive (PPD)-8, entitled *National Preparedness*, was signed by President Obama on March 30, 2011. PPD-8 provides the outlines of an “all-of-Nation” preparedness approach including a national preparedness goal, a national preparedness system, and planning and definitions of terms used with the PPD itself. More definitive guidance from the PPD-8 that HRF leaders can use for planning and preparedness guidance is supposed to be published in September 2011. PPD-8 supersedes the 2003 HSPD-8; National Preparedness that established priorities for national planning. The NRF has 15 national planning scenarios that depict a credible range of terrorist attacks, natural disasters, and related impacts that the HRF can use as a baseline for planning until further PPD-8 products are published. Eleven of the 15 national planning scenarios refer to CBRNE attacks. Based on common characteristics the national planning scenarios are grouped into eight “key scenario sets” to further facilitate integrated response planning. The NRF’s key scenario sets are supported by seven incident annexes, including two CBRNE specific annexes, the biological incident, and the nuclear/radiological incident annexes. The nation’s response to a chemical weapons event is covered by the Emergency Support Function #10 Annex, *Oil and Hazardous Materials Response*, since chemical agents fall under hazardous materials response. It is important to note that to date NORTHCOM has followed the CBRNE scenarios in developing contingency plans (CONPLANS) but was criticized in a 2009 GAO audit of the CCMRF for poor integration with the plans of civilian response organizations (GAO, 2009). The national planning scenarios and incidents annexes provide a baseline for HRF planning and potential training scenarios until the PPD-8 is fully implemented. Additionally, plans that address different hazards exist in most FEMA regions and in the Regional Contingency Plans (RCPs) and Area Contingency Plans (ACPs) developed under NCP guidelines. The HRFs can employ these existing region-specific plans such as FEMA Region VII’s New Madrid Seismic Zone Response Plan.

## **B. DOMESTIC HAZMAT AND CBRNE RESPONSE LAWS**

The foundations of the nation's hazardous materials or CBRNE response planning, equipment, training, and funding derive from environmental laws. These laws include the Comprehensive Environmental Response, Compensation & Liability Act (CERCLA) (33 USC 103), the Superfund Amendment & Reauthorization Act (SARA) (42 USC), the NCP, and the Hazardous Waste Operations and Emergency Response 29 Code of Federal Regulations (CRF) 1910.120. These statutory standards help protect citizens, industry, and communities across the United States from hazardous materials on a daily basis. These laws define response authorities for public and private agencies; define hazardous substances, emergency planning, and "community right to know." Additionally, they define response clean-up requirements and provide a billion dollar fund for public and private agencies to respond and recover from all hazardous materials incidents. The 29 CFR 1910.120 (Hazardous Waste Operations and Emergency Response) defines legally required protective measures and training for responders within the United States dealing with HAZMAT or CBRNE. First responders, local emergency planning committees, federal agencies, and state emergency response commissions operate in accordance with these laws, contingency plans, and funding for disasters and CBRNE events.

First implemented in 1968, NCP outlines command structures for CBRNE and oil and hazardous materials incident disasters. The NCP authorizes the Coast Guard and EPA manage the National Response System (NRS), the National Response Center (NRC), the multi-agency National Response Team (NRT), and 13 multiagency Regional Response Teams (RRTs) distributed across the U.S. and its territories. The RRT provide oversight for the development of RCP and ACP. Run by the Coast Guard, the NRC handles over 30,000 CBRNE and hazardous material "incident notifications" each year. (National Response Team presentation, 2011) Under the NCP, the EPA, and Coast Guard appoint federal on-scene coordinators (OSCs) who possess specific training and legal authority to control all aspects of a domestic CBRNE response.

## NCP Preparedness

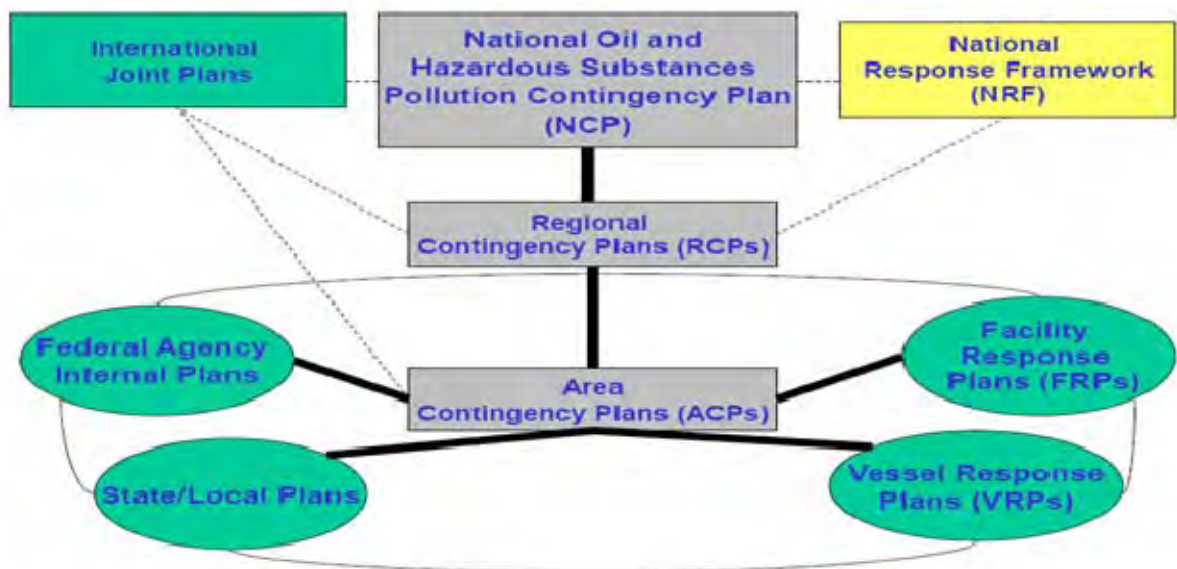

Figure 10. The National Oil and Hazardous Substances Pollution Contingency Plan (NCP)  
(From EPA, 2011)

Adopted by the Department of Homeland Security, the National Fire Protection Association (NFPA) 472 *Standard for Competence of Responders to Hazardous Materials/Weapons of Mass Destruction Incidents* describes the competencies and standards for personnel conducting domestic HAZMAT/CBRNE responses (2008). During domestic CBRNE response operations, these laws *subordinate* military doctrine and military authority while defining command structures under the NRF, NIMS, and the NCP. Understanding these domestic CBRNE and all-hazards response fundamentals will help leaders build and employ a better HRF. Table 1 outlines some recommended laws, guidelines, and HSPDs for the HRF. These standards provide a template for meeting future HRF mission demands and reduce redundant organizations and guidelines that form the “best practices” in response organizations.

Table 1. HRF Recommended Civilian Response Standards

| <b>Civilian Standards</b>   | <b>What</b>  | <b>Why</b>   | <b>Who Used by:</b>  |
|---|--|--|--|
| HSPD-5 NRF/NIMS National Response Framework and National Incident Management System   | Framework, principles, language used for domestic response operations.                   | Legal requirement. Supports HRF interoperability.  | Local, state, and federal response agencies.   |
| PPD-8 "National Preparedness"   | National preparedness system, national preparedness goal,                                | Supports preparedness, planning,   | Local, state, and federal response agencies.   |
| 40 CFR Part 300 Protection of the Environment and National Oil and Hazardous Substances Pollution Contingency Plan or National Contingency Plan | Defines what HAZMAT is and what agencies have statutory response authorities.            | Legal requirement. Defines DOE, EPA, USCG, DoD, roles in HAZMAT (CBRNE) response. Supports HRF interoperability.                           | Local, state, and federal response agencies.   |
| 29 CFR 1910.120, Hazardous Waste Operations and Emergency Response.   | Emergency response operations for releases or substantial threats of HAZMAT.             | Legal requirement. Defines HAZMAT protective measures & standards. Supports HRF interoperability.  | Local, state, and federal response agencies.   |
| 49 CFR 180-185 Hazardous Materials Regulations (HMR) are issued by the DOT's Pipeline Hazardous Materials Safety Administration (PHMSA).        | Addresses HAZMAT classification, packaging, emergency response information and training. | Legal requirement. Provides HRF personnel critical HAZMAT safety, packaging and transportation information. Supports HRF interoperability. | Local, state, and federal response agencies.   |
| NFPA 472 (National Fire Protection Academy) Basic standards of responder competence for HAZMAT & CBRNE.   | Performance standards to ensure responders can respond to HAZMAT.                        | Best practices guidelines. Provides protective measures and steps for effective/safe HAZMAT response. Supports HRF interoperability.       | Local, state, and federal response agencies.   |
| NIOSH (National Institute for Occupational Health and Safety) – HAZMAT personal protective equipment (PPE) and exposure guidelines.             | PPE specifications based on HAZMAT and exposures.  | Provides response PPE and equipment safety standards. Supports HRF interoperability.   | Local, state, and federal response agencies.   |
| ISO 17025 (International Organization Standardization)  | Laboratory and sampling guidelines used for HAZMAT.                                      | Laboratory standards and methodologies for handling of HAZMAT. Supports HRF interoperability and collaboration with LRN.                   | Used by CDC's Laboratory Response Network (LRN), local, state, federal and private labs. |

In an August 2010, HRF conference in Kansas City, Missouri, NORTHCOM and NGB leaders met to discuss the development of the HRF and DoD's CBRN enterprise.

The conference discussed at length potential DoD command and control scenarios for a domestic CBRNE incident and contingency plans or “CONPLANS” for the HRF and DoD’s CBRN enterprise. The conference also discussed the HRF’s missions in terms of military doctrine, the joint planning and execution system (JOPES) and NORTHCOM’s CBRNE contingency plan known as the CONPLAN 3500. None of the conference materials mentioned the HRF operating under the NCP or under NRF-stipulated Emergency Support Function (ESF)-10 (oil and hazardous materials) response guidelines. The conference product (Figure 11) reflects a DoD-centric command and control and depicts the HRF and military forces almost as battlefield “terrain owners” rather than supporting agencies operating within a domestic response environment.

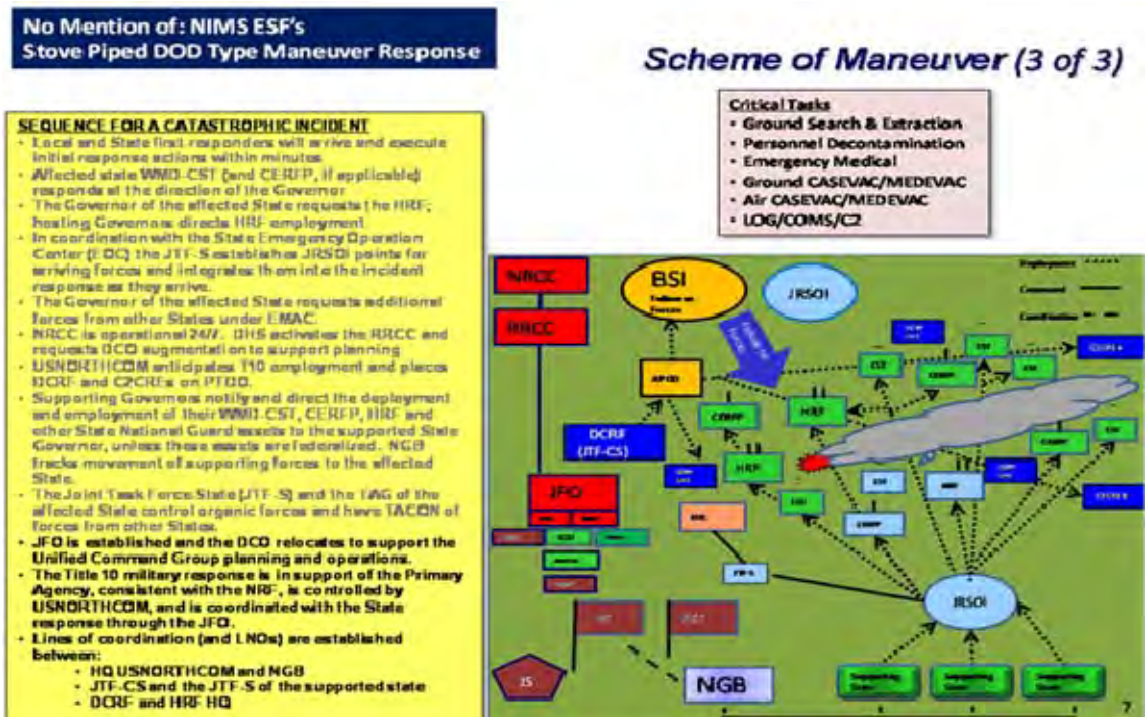

Figure 11. National Guard Bureau and NORTHCOM Conference Products (From National Guard Bureau, 2010)

While the products describe DoD operational constructs and command relations, they omit the NIMS operational level and ICS tactical level command structures, as well as the separate emergency support functions that the HRF might support during a response. Local, state, and federal agencies routinely pool resources under a unified command or under a specific ESF command. The HRF’s subordinate elements could be

assigned under a unified command or an ESF command to better integrate resources with local, state, and federal agencies. The HRFs SAR, medical, and security elements could be assigned under an ESF-9 (urban search and rescue), ESF-8 (public health and medical services), and ESF 13 (public safety and security) commands respectively. Many of elements of the 22 CST's that deployed to Hurricane Katrina worked under a unified EPA and Coast Guard ESF-10 command.

The products in Figure 11 depict a potential short-coming and “gap” faced by the HRF and the CBRN enterprise: the CONPLAN 3500 does not represent any legal authorities. In a September 2010, Naval Postgraduate School presentation, Colonel John Gereski, a NORTHCOM Staff Judge Advocate officer plainly stated, “A military plan does not constitute legal authority” (Gereski, 2010). Employing the HRF under military command and control system within a domestic response that is separate from the statutorily based NCP, NIMS, and ICS systems potentially threatens a divergent command structure and violates the NRF principle of unity of effort. The NCP is the nation's CBRNE response plan and HRF leaders should integrate the HRF into existing NCP based RCP and ACP plans and response practices. The NCP and its interagency-intergovernmental sub-organizations have a track record of success in response to large incidents such as the Exxon Valdez and the Deepwater Horizon oil spills as well as thousands of smaller CBRNE and hazardous materials incidents.

### **C. INTELLIGENCE OVERSIGHT AND INCIDENT AWARENESS AND ASSESSMENT**

The Intelligence Oversight Act of 1980 stems from the 1975 post-Watergate United States Senate Select Committee to Study Governmental Operations with Respect to Intelligence Activities, also known as the “Church Committee” hearings, chaired by Senator Frank Church (Democrat, Idaho). Wrongful use of Army, FBI, and CIA intelligence resources resulted in a series of laws and congressional oversight to end politically motivated use or improper employment of intelligence agencies. The laws require that all FBI, CIA, and DoD intelligence, counter-intelligence, and intelligence actives are conducted in accordance with all U.S. laws and presidential executive orders to prevent the abuse of civil liberties by intelligence agencies within the *U.S.* *The*



*Intelligence Community Legal Reference Book* (Office of the Director of National Intelligence, 2007) and DoD intelligence manuals provide guidelines and information on the suite of laws and guidelines from the National Security Act of 1947 to the U.S.A. PATRIOT Improvement and Reauthorization Act of 2005. Knowledge of these laws and legal awareness will help ensure the HRF operates effectively and legally within the U.S.

A decade of rapid technological and intelligence advancements now compound intelligence oversight issues for most military units. Intelligence capabilities are now embedded in virtually every military element. Advanced encrypted communications, information technology systems, sensor systems, robots, and unmanned aerial systems (UAS) are common in many units. All of these systems are critical to the “network centric” warfighting capability employed in Iraq and Afghanistan. These same systems can be easily construed as intelligence collection assets when operating within the U.S. For example, domestic UAS employment by the DoD on the U.S.-Mexican Border and elsewhere has been a topic of recent debate. Governors may allow different degrees of operational latitude for the National Guard’s UAS systems and intelligence units than the Secretary of Defense might allow federal military forces. Different state and federal level approaches to intelligence oversight could potentially complicate the HRF’s employment of the communications and new information sharing systems that provide units a “common operating picture” (COP).

Presently, Incident Awareness and Assessment (IAA) defines the terms and proper use practices for the domestic employment of DoD intelligence assets within the U.S. domestic environment. As earlier noted, the U.S. Army’s TC 2-91 *Intelligence Handbook for Civil Support Operations* (Headquarters, Department of the Army 2009), the FM-28 *Civil Support Operations* (Headquarters, Department of the Army, 2010), and the First Air Force Defense Support to Civil Authorities (DSCA) *Air Support Handbook* (First Air Force, 2011) all provide information regarding IAA guidelines for air and ground forces. Increasingly civilian law enforcement and emergency management agencies are using cellular phone triangulation and Geospatial Information Systems (GIS)-linked social media information to direct criminal and emergency response information. Direct employment of these civilian practices by the HRF could result in

intelligence oversight and civil liberties violations damaging to the HRF and DoD in general. Continuous legal counsel, adherence to intelligence oversight laws, and knowledge of IAA practices can safeguard the HRF from legal and civil liberty pitfalls that have created setbacks for other DoD organizations.

#### **D. THE POSSE COMITATUS ACT AND THE INSURRECTION ACT**

U.S. domestic laws, different levels of government, and types of U.S. military components add to the conflicts of domestic military employment that previous CBRNE units have faced. U.S. military forces typically fall under into active, reserve, and National Guard components or categories. Active duty and reserve forces typically fall under U.S. Code (USC) Title 10 (T-10) as federal forces while the National Guard's Army National Guard and Air National Guard comprise USC Title 32 (T-32) as state-level forces. The federal forces answer to the President and Secretary of Defense when deployed for domestic operations. National Guard or state forces follow DoD protocols but are subordinated to the governor until activated by the President, typically for overseas deployments. Although uniforms and equipment might be alike, the legal status of federal forces and state forces are drastically different due to U.S laws. In a domestic role all federal forces answer to the President and follow strict mission assignments issued by the Secretary of Defense. Federal forces are usually restricted from law enforcement roles under the Posse Comitatus Act of 1878 as stated in United States Code (USC):

Use of Army and Air Force as Posse Comitatus, Whoever, except in cases and under circumstances expressly authorized by the Constitution or Act of Congress, willfully uses any part of the Army or the Air Force as a posse comitatus or otherwise to execute the laws shall be fined under this title or imprisoned not more than two years, or both. (18 USC, § 1385, 1878)

When operating at a state level, National Guard elements do not fall under Posse Comitatus and can conduct law enforcement and a wide range of tasks when ordered by a governor. Inter-state Emergency Management Assistance Compact (EMAC) agreements can also specify law enforcement authority for National Guard personnel responding to disasters in other states. Since all disasters have local or state-level impacts, the National

Guard forces are often “forward deployed” and already operating when incidents occur. With fewer proscriptions such as the Posse Comitatus Act, and with state-level response roles extending to the colonial era, Guard forces often have greater utility as well as proximity to the majority of America’s disasters.

Since its founding, the U.S. has historically regarded domestic military employment cautiously and employed the Posse Comitatus Act widely since its inception in 1878. The few exceptions include the large deployment of federal troops to the South during reconstruction and a federal military response to the 1992 Los Angeles riots under the Insurrection Act of 1807. The Insurrection Act has been a vehicle to enforce U.S. law during the civil rights era and to also restore order during large disturbances. Regardless of CBRNE or all-hazards type missions, the Posse Comitatus Act, strict Secretary of Defense oversight of federal forces and the strict mission assignments of federal forces define the great differences and day-to-day operational constraints existing between America’s state and federal-level CBRNE forces.

The Insurrection Act and the opposing Posse Comitatus Act represent the tension and periodic conflicts that can arise regarding military operations within the U.S. Few legal examples better reflect the complexity and contradictions in American democracy and how they that might impact domestic military operations. In a successful effort to repeal changes that had increased presidential Insurrection Act authorities in the 2007 John Warner National Defense Authorization Act, Senator Patrick Leahy of Vermont referred to these laws as a “useful friction” in determining appropriate domestic response measures while limiting the powers of government (Tahlequah Daily Press, 2007). In light of potential contradictions, HRF leaders and National Guard leaders must be knowledgeable in both the Posse Comitatus Act and Insurrection Act to better serve elected officials and avoid civil liberty concerns while protecting the American public.

With proper integration of civilian response laws and standards the HRF can improve the nation’s regional CBRNE response capabilities. The HRF’s “civil-military” hybrid mission presents unique legal and operational challenges. While most military units employ “doctrine” for overseas missions and operate outside of tort law and federal regulations the HRF must follow both DoD and civilian emergency response standards in

its domestic role. Selection and adherence to proper DoD guidance and civilian laws can help the HRF meet future audits and serve as “best practices” guidelines for response operations. In all response operations, HRF leaders must take care to adhere to Posse Comitatus, intelligence oversight requirements, DoD IAA practices, and future guidelines provided by PPD-8. For CBRNE response the NFPA 472 and 29 CFR 1910.120 provided legal guidelines and practices. For CBRNE response operations, fully integrating the HRF under the direction of an EPA or Coast Guard appointed OSC and within an ESF-10 based response is essential for employing the HRF’s resources effectively and within the legal guidelines and routine practices established by the NCP.

THIS PAGE INTENTIONALLY LEFT BLANK

#### **IV. CASE STUDY: THE ISRAELI HOME FRONT COMMAND**

The 1990 Persian Gulf War shifted Israel's traditional battle fronts from its borders to city centers. In response, Israel reformed into civil defense capabilities creating within the Israeli Defense Force (IDF), a new organization called the Home Front Command (HFC). The HFC and the U.S. National Guard's response capabilities have developed from different laws, circumstances, and nations but have developed many of the same capabilities in the defense of their homelands.

Israel's HFC provides the basis for a case study for a number of reasons. The HFC and National Guard both support democratically elected governments and both use a blend of full-time and part-time forces dedicated to domestic response operations. Also, many exchange visits between senior National Guard officers and the HFC have occurred. Routinely challenged by suicide bombings and rocket barrages from its borders, the HFC is essentially operating in "wartime" conditions and exerts greater authority across Israel than its National Guard counter-part. The HFC is empowered to coordinate training and response across industries, ministries, hospitals, and communities. Due to laws restricting domestic military employment and no persistent terrorist threat on U.S. borders, the National Guard has more proscribed authorities.

With search and rescue, CBRNE, decontamination, and medical support the National Guard's 10 new HRFs will have domestic response capabilities that mirror some of the HFC's regional or district level organizations. National Guard leaders should look at the HFC example to build the best possible capabilities into the new HRF. A sharing of techniques and procedures between organizations will benefit both. Also, the HFC already has established training programs and military schools that the National Guard can emulate for its own forces. Israel's use of the HFC forces for humanitarian rescue mission following earthquakes in Haiti, Turkey, Greece, and other disasters have served to increase organization proficiency. In a method of transparent government and manner, similar to U.S. Government Accountability Office reports critical of the National Guard's CBRNE elements, Israel's Winograd report (Winograd, 2008) harshly appraised the performance of the IDF and HFC during the 2006 Second Lebanon War. In addition, a

Guard focus on Israeli rapid response measures and experience gained by the HFC during the Second Lebanon War could identify “best practices” for the Guard as a whole that are applicable both to terrorist incidents and natural disasters. Further exchanges of information and training partnerships can help the forces of both countries disseminate information, potentially save dollars, and, more importantly, save lives.

Comparing the domestic operations of U.S. military forces to those of a different nation provides some challenges. No other country has a state and federal system of government, the land-mass, and population as seen in the U.S., thus making a direct civil-military comparisons difficult. Few countries have a U.S. style “grass-roots” political system in which a provincial or state governor can tell a national-level leader “no” to prospective national level assistance or potentially act to impede a large disaster response. Still, best practices from different types of government might serve as examples for the National Guard’s HRF to adapt. Furthermore, domestic legal systems, demographics, and civilian components of government also influence how a nation employs its military.

The Superfund Amendment Reauthorization Act and the Stafford Act are two laws of great significance to U.S. response operations. These laws give the civilian U.S. Federal Emergency Management Agency (FEMA) and the Environmental Protection Agency (EPA) statutory overall response authority to include controlling U.S. military forces during a CBRNE or disaster response. Consequently, U.S. forces, unlike some foreign military counterparts, must configure themselves to meet many legally stipulated civilian response standards inside the U.S.

The U.S. is also unique in that since the conclusion of skirmishes in Mexico in 1917, the U.S. military has structured itself almost exclusively to operate overseas whereas Israeli and European armies are configured to fight on their own soil. The U.S. was born of a revolution, partially driven against standing military formations within its borders. These somewhat unique aspects of American culture and history create political inertia against federal level active-duty military forces operating outside the purview of a governor’s or state-level control.

## **A. ISRAELI HISTORY AND EXPERIENCE**

Israel's present HFC configuration was created in 1992, following Scud missile attacks during the 1991 Persian Gulf War (Israel Defense Force, n.d. a). Striking in Israel's city centers against large civilian populaces, the Scuds challenged conventional disaster response and required greater cohesion in employing resources during response operations. The Scud missiles required a combined civilian and military response due to extensive damage and to the missiles' chemical weapon capable warhead. The IDF successfully implemented distribution of individual CBRNE protective equipment, media engagement, medical response support, and rescue efforts during these attacks (Israeli Defense Force, n.d. a). Post-Gulf War analysis indicated that an organization with greater authority and autonomy from Israel's existing military regional commands was needed to protect Israel's populated areas.

The HFC traces its origins to 1948 when the HAGA—the Hebrew acronym for civil defense—was created (Israel Defense Force n.d. b). The HAGA was a response to the 1948 Egyptian aerial bombing of Tel Aviv, which, like the Scuds 42 years later, caused damage to the civilian populace and buildings. In 1951, the Knesset further codified the HAGA's legal status with a law stating “to take all the necessary steps to protect the populace in the event of any attack by hostile forces or to minimize the results of such an attack, the emphasis being on saving lives” (Israeli Defense Force, n.d. b). The bombardment of Jerusalem during the 1967 Six Day War and the 1973 Yom Kippur War demonstrated that greater government preparation was needed to support and engage the Israeli populace during a national crisis. With front-line military demands placed on reserve units, Israel realized that a blend of individual civilian preparation combined with police and security force capabilities were needed to rapidly provide rescue and limit damage in rear areas. Still, the Yom Kippur War and Six Day War did not bring to bear the impacts across the greater population seen later with the Scud missiles in 1991.

Israeli's settlements form another element of the HFC that initially fell under a separate command called HAG'MAR, which is the Hebrew term for Regional Defense. Prior to the establishment of an Israeli state, Jewish settlements had organic security forces for protection during periods of upheaval in Palestine. During the 1948 War of



Independence, the settlements served as a defensive component and were sometimes besieged. In the wake of the Yom Kippur War, the settlements were further fortified especially in areas of potential fighting. The HAG'MAR safeguarded settlements through patrol activities, physical security, lighting, and other security measures. In 1997, the HAG'MAR was combined with the HAGA division under the HFC to further consolidate rear area operations under the Chief Command Officer for the HAGA and HAG'MAR.

## **B. CREATION OF THE HOME FRONT COMMAND**

The 1992 creation of the HFC was a significant transformation of Israeli defense activities and boundaries that reflected evolving threats against Israel's populace. Prior to the HFC establishment, Israel was divided into three regional commands known as the Southern, Central and Northern commands (Israeli Defense Force, n.d. b). The IDF's battlefield or "maneuver" general officers in charge of each of these three commands had to contend with frontline combat operations on Israel's borders as well as efforts to secure civilian populations and rear areas. With the three original commands retaining some control over key routes into their areas of operation, the HFC was established as a fourth IDF command under Brigadier General Ze'ev Livneh (Israeli Defense Force, n.d. b). It was viewed that development of the HFC relieved the maneuver commanders of rear area and civil operations so they could better focus on military threats in the northern, central, and southern regions. The HFC itself is divided into five regions or districts that stretch from Acre in the north to Ashkelon in the south and an eastern line from Judea to Samaria covering the bulk of Israel's populated areas. The HFC districts as depicted in Figure 12 are: the Northern District, Dan District, Jerusalem District, Central District, and the Southern District.



Figure 12. HFC Districts (From Israeli Defense Forces, n.d. b)

Legally, the HFC has significant powers to organize, train, and prepare Israel to manage the consequences of terrorist attacks, warfare, and natural disasters. These powers stem from paragraph two of the 5711–1951 Civil Defense Law or “the Hagan Law” and Civil Defense Regulations 5733–1973 (Israeli Defense Forces, n.d. b). These laws stipulate in detail the HFC’s authority:

5711-1951 Civil Defense Law Paragraph 2.f: To train and direct aid organizations to fulfill their functions in the field of civil defense. 2.i: To train the public in matters of civil defense. 2.j: ... To undertake any other action necessary to fulfill its function pursuant to the Civil Defense statutes.

5733-1973 Civil Defense Regulations (Factories, Institutions Equipment and Training their employees) determines the power to prepare those in charge and to train employees at the factory. (Israeli Defense Forces, n.d. b)

From this legal basis, the HFC is able to direct many functions to prepare and protect the populace with a “whole of nation” approach. The HFC conducts training in schools, factories, government ministries, national exercises, alert systems, distribution of protective equipment, and search and rescue capabilities. Based on actual earthquake, car bomb, and missile response operations, the HFC has developed both regular and reserve units that conduct medical, CBRNE, and recently added search and rescue capabilities. The structural diagram Figure 13 describes some of the HFC organizational and operational regional structures.

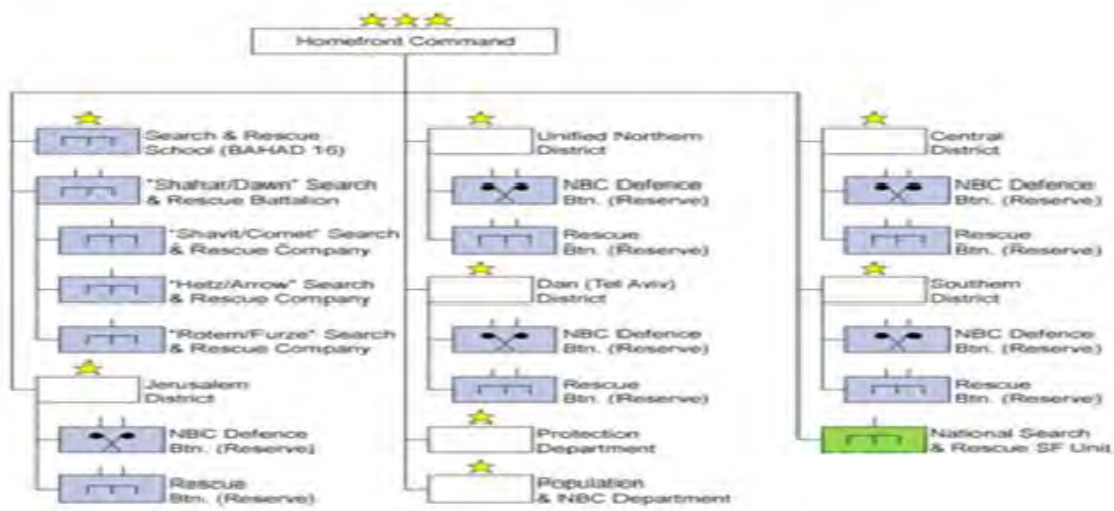

Figure 13. HFC Organizational and Operational Regional Structures (From IDF, n.d. b)

The year 2006 was a crucible year for the HFC. A conflict-driven disaster with parallels to America’s Hurricane Katrina event occurred within Israel as part of the Second Lebanon War. Possessing unprecedented missile and artillery capabilities supplemented by foreign nations, Hezbollah and Hamas unleashed approximately 4000 missiles carrying tons of explosives and shrapnel upon Israel’s populated areas (Raday, 2006). Striking predominately in Israel’s north, an estimated 330,000 Israelis were displaced, 43 civilians killed, and 4262 wounded (Raday, 2006). Over 6000 homes were destroyed, critical infrastructure was damaged, and Haifa, Israel’s third largest city, suffered hundreds of missile strikes in a 34-day period (Greenhill, 2007). Although confined to northern Israel and in proximity to the Gaza Strip, the conflict brought tremendous social and economic dislocation to much of Israel’s population. Many of

Israel's businesses, schools, railroads, hospitals, crops, and livestock were destroyed or damaged by the barrages. Hundreds of thousands were forced into crowded government shelters, military bases, and temporary tent camps. Others moved in with relatives or to hotels outside of missile range.

Mainly related to the conduct of military operations inside Lebanon, the Winograd Commission was an Israeli national level inquiry into the conduct of the Second Lebanon War. The commission was critical of the Olmert government's handling of the war, senior-level decision making, and IDF battlefield shortcomings. The HFC's performance was less criticized. Despite the vast scale of dislocation and damage caused by attacks, faults were found in alert systems and quality of the shelters available to the public. Alerts were too broad based and sent too many people into shelters for too long. In some cases, alerts failed and the public was not notified of incoming missiles before they struck. Shelters often lacked proper facilities such as air conditioning and sufficient toilets, and many shelters were unsanitary (Raday, 2006). Like American GAO audits, the Winograd Commission demonstrates another important parallel between the U.S. HRF and Israel's HFC—*accountability* to the citizens and democracy that each organization represents.

Challenged by the events of the Second Lebanon War, the HFC set about addressing shortcomings identified in the Winograd Commission report. The HFC has placed great effort into annual nationwide exercises. The latest of these exercises, called Turning Point Four, occurred in May 2010 (Leyden, 2010). The five-day drill focused on distribution of CBRNE protection kits, search and rescue operations, movement to shelters, use of underground parking areas for services, use of safe areas, hospital operations, and testing Israel's alert systems.

Central to improving alerts for the civilian population is the "Color Red" notification system. Originally developed as a sniper detection system for use near Gaza area, the Color Red system is linked to radar systems to rapidly determine a missile launch and probable impact area (Opall-Rome, 2009). Since 2006, Color Red coverage has expanded throughout the country. Also the predicted missile impact area has been

greatly reduced to limit portions of the population affected by an alert. Of greater importance, Israel is linking the alerts for missile and other threats to cell phones and other media.

Now Israel is launching a national cell phone alert system to target emergency information about impending natural or manmade disasters to affected residents. The system alerts residents even if cell phones are in silent mode, taking over the cell phone system to prevent the kind of service outages experienced in the aftermath of events like Hurricane Katrina or the Sept. 11, 2001, terrorist attacks. (Greenhill, 2010)

With Color Red and more alert sirens providing greater warning to missiles in a more discrete radius, the HFC has demonstrated increased ability to protect the populace against increasing enemy missile capabilities. Missile strikes on Ashkelon, Sderot, and other cities presently continue to test the HFC's capabilities and the Israeli population.

### **C. COMPARISONS: THE HOME FRONT COMMAND AND U.S. NATIONAL GUARD**

In summary, the HFC is a militarized civil defense command on a war-time footing with unprecedented response powers and unity of command over Israel's population, private sector, and government with a democratic state. While this is potentially a negative comment, it does reflect a reality that Israel has suffered increased military attacks on its civil population over the past 20 years. Experience from the Persian Gulf War, Second Lebanon War, the Winograd Commission, and sustained barrages have added to the HFC's experience. Additional humanitarian rescue and medical operations in Haiti, Turkey, Kenya, Greece, and Pakistan have also contributed to the HFC's professionalism.

Legally, the HFC is very different from its U.S. National Guard counterpart. The HFC's power and organization is derived from civil defense related imperatives. With limited domestic military threats, National Guard forces have a largely disaster-related role in support of state and federal civilian organizations with statutory authority over response operations. Still, both forces have developed very similar capabilities within the

different countries they support. Despite different legal authorities, threats, and geography, both organizations and nations can import and export lessons that benefit their populations.

The experience of the HFC provides many lessons learned that the National Guard and the 10 new regional HRFs can employ. The fact that National Guard commanders, Lieutenant General (LTG) Stephen Blum and General (GEN) Craig McKinley, have made well publicized trips to Israel reflects the similar mission that the HFC shares with the National Guard elements. The HFC mobilization process, search and rescue, and alerts are areas of potential focus for Guard leaders.

Like the regional HRFs, elements of the HFC bring regional CBRNE, search and rescue, decontamination, emergency triage, and medical treatment to authorities during a disaster or terrorist event. At a national level, the HFC has greater control to train and manage the response operations of ministries, and populated areas. Many of the HFC's comparable national functions belong to the U.S. Department of Homeland Security's civilian agencies like FEMA and state-level agencies that follow the U.S. National Response Framework (NRF) (DHS, 2010). However, during extreme situations, the Insurrection Act or National Emergency Powers allow the U.S. President to place the Guard or other federal military elements in charge of response and civil defense operations. A governor can also place the National Guard in charge of state level and local response operations. In such situations, the powers of the Guard and or federal military forces would temporarily parallel some of the HFC's scope of authority.

The HFC's mobilization of reserve forces, marshaling of equipment, and alert systems are practices the Guard seeks to emulate for the CST, CERFPs, and the new HRF. At the CST Commanders Conference on August 22, 2006, LTG Blum declared his war on the Guard's "antiquated phone roster and armory based alert system that slow the Guard's response" (Blum 2006). Blum advocated the Israeli use of multimedia, pagers, and text messages to let soldiers know where to report and to rapidly move equipment at staging areas for emergencies. LTG Blum stated repeatedly that the "phone roster" and soldiers reporting to armories instead of locations close to an incident will continue to delay the Guard's response and cost lives (Blum, 2006).

From the Table 2, it is apparent that the Guard’s suite of capabilities is close to the HFC’s developed capabilities.

Table 2. HRF and HFC Capabilities

| <b>Capabilities</b>  | <b>Guard HRF, CST, CERFP</b>  | <b>HFC</b>  |
|--|---|---|
| Regional CBRNE Response  | Yes. 57 CSTs, 17 CERFPs, 10 HRF’s decon capabilities.) EPA and USCG lead agencies.                                  | Yes. 5 Reserve NBC Defense Battalion Population & NBC Dept.           |
| Medical  | Yes. 17 CERFP & 10 HRF with Triage, Mass Casualty Support, Health and Human Services and Hospital lead agencies.    | Yes. Mass Casualty and Cooperation with Hospital Staff.               |
| Search and Rescue (SAR)  | Yes. 17 CERFPs, 10 HRFs. Local, State, FEMA lead agency.  | Yes. 1 Active SAR Btn, 5 Reserve SAR Btn, National SAR unit           |
| Training: Schools, Industries, Hospital Staff, Special Needs Community, Ministries | No. Participates in National Level Exercises Only. No Specified Training Role. Local, State, Federal Agencies Lead. | Yes. National Level Exercises, (Turning Point) Institutional Training |
| CBRNE Civilian Protection Kits   | No U.S. equivalent  | Population & NBC Department   |
| Evacuation and Shelter Authority   | No. State and Federal Authority Only. Guard can support.  | Yes. Protection Department  |
| Missile Response and Alert Systems   | No. No U.S. equivalent  | Yes. Color Red and other functions.                                   |

The two organizations have great similarities; yet, legally and authoritatively, they are very different. The HFC’s ability to train and work with many parts of Israeli society and government helps to provide a great depth of training and response knowledge prior to an incident. In a mainly supporting role to civilian response agencies, the National Guard is confined to a more reactive role than its HFC counterpart despite the Guard’s high training levels.

The nature of Israel’s threats requires such capabilities from the HFC, whereas the lower threat and greater restrictions placed on military response by U.S. laws reduce the Guard’s leading domestic roles. The HFC’s consolidated response authority and capabilities probably exceed the U.S. civil defense efforts of World War II. Still, the National Guard’s CBRNE units participate in hundreds of responses, training events, and National Special Security Events (NSSE) like the 2009 inauguration. In addition to a

domestic mission, the National Guard, like its IDF reserve counterpart, also contributes greatly to the national war fighting capabilities. Hundreds of thousands of Guard soldiers have deployed to Iraq, Afghanistan, Horn of Africa, and Kuwait for combat operations. Continued combat deployments seem to indicate that the National Guard will not become a constabulary or exclusively a rescue force.

Still, the U.S. should follow Israel's use of multimedia to alert and deploy Guard forces. The older sirens and designated shelters linked to the U.S. civil defense efforts of the 1950s and 1960s are no longer marked or functional. Also, threats to the U.S., like Israel, have the potential to grow and change in capability and sophistication. The upsurge in violence and advanced weaponry of Mexico's drug cartels indicate such a change. Whether identified by a U.S. GAO audit or the Winograd Commission, adaptations and improvements should be made before incidents happen. The experiences of the HFC and previous U.S. CBRNE organizations should be considered as the HRF program develops now. Better alerts, a review of shelter locations and streamlined mobilization of forces for domestic incidents will not require a U.S. policy change regarding the use of military forces and can save both training time and dollars now.



THIS PAGE INTENTIONALLY LEFT BLANK

## **V. RECOMMENDATIONS AND CONCLUSIONS FOR THE HRF**

### **A. A POTENTIAL HRF RESPONSE SCENARIO**

Warning sirens wail and missiles impact in urban areas as ambulances race and hundreds are displaced to shelters. Cued by a missile alert system and new multimedia alerts via television, radio and text messages; HRF members report to staging areas near the worst impacted areas. Evacuating holiday shoppers from a collapsed shopping mall and an adjoining parking facility is complicated by a vehicle borne improvised explosive devices (VBIED) that was remotely detonated beneath an interstate overpass near the area with the most casualties. Search and rescue (SAR) personnel begin to move via alternate routes as HRF medical personnel arrive via helicopter at the shopping mall with advanced life-support system (ALS) capabilities. HRF security personnel move to relieve burdened local police and border patrol agents at traffic control points (TCP) and to assist the flow of displaced persons out of the worst-hit areas. Working alongside local fire departments and the EPA, highly trained CST personnel move to check for any possible CBRNE hazards before conducting inspections of gas lines and pressurized industrial chemical storage tanks to ensure responder safety near the impact zones. Older structures with asbestos and other hazardous building materials containing pulmonary hazards are collapsed and burning near one of the incident site locations. Aerosolized silica powder dust from crushed glass and alkali dust from concrete add to the pulmonary hazards. This will require the HRF to provide decontamination capabilities for fire, utility, police, and construction workers involved in the recovery process. A cartel “stay behind team” begins sniping at responders near another impact site forcing the HRF to allocate additional security personnel to support both rescue efforts and local law enforcement battling cartel members. Additional IEDs and VBIEDs detonate or are discovered near routes into impacted areas further slowing response efforts.

Twenty hours after the multiple missile impacts, sniping and IEDs, the weight of military and multiagency support to the response begins to tell. Police, public works, communications, power generation, transportation, law enforcement, medical facilities, refugee camps, and public affairs have been augmented by state, federal, and military

personnel as an initially chaotic response begins to mature. Governors demand additional federal resources and a Presidential Disaster Declaration while various political factions clamor for a cross-border strike. On cue from state emergency management, the HRF staff helps transport supplies to newly opened public shelters just outside of current missile ranges. National Guard forces and the Army Corps of Engineers provide power to the damaged areas for rescue, medical, and fire services; all require supplementary power for lighting systems, decontamination equipment, and new shelters without electricity.

Unmanned aerial systems (UAS) provide the HRF live feed from near the incident sites for additional IEDs and missile damage. The multi-spectral imaging and thermal-capable UAS systems also detect potential fire “hotspots” and hazardous materials releases as a result of the attacks. As at “ground zero” in New York City and at Hurricane Katrina, the CSTs attached to the HRF provide the backbone of response communications with the secure Trojan Spirit linked mobile Secret Internet Protocol Router (SIPR) network and civilian response communications. Outside of the state and local response, NORTHCOM/NORAD begins to identify potential targets in known cartel areas of operations near the impacted areas while the State Department begins engagement with appropriate counterparts. In other regions, government agencies begin to look for groups specifically linked to the attacks while the U.S. Navy and Coast Guard search for submarines that might be moving weapons in addition to drugs.

After a 48-hour period, additional National Guard HRF personnel supplement the border patrol and customs officials at border checkpoints to help the resumption of normal cross border commerce while looking for drugs, weapons, and cartel members. The CST personnel continue work with fire departments and state and federal level EPAs to detect and identify hazards in the impacted areas. To counter explosive hazards DoD explosive ordinance (EOD) teams work with police and fire to render safe any unexploded missiles and IEDs. HRF medical personnel have provided “surge” medical capacity to support local hospitals, emergency medical services (EMS), and to the shelters near the impacted areas. Other HRF and attached CERFP personnel continue to decontaminate responders and equipment working in the impacted areas. A portion of these assets are posted near major hospitals to decontaminate victims and ambulances

that might be covered with asbestos dust or other toxic materials. The collapsed shopping mall and parking garage sites are managed by local fire and FEMA USAR teams that direct HRF personnel searching for bodies and extracting victims. State and federal agencies continue to request HRF resources to support rapidly established shelters. Occasional rocket fire continues to tax response resources but produce fewer casualties and damage than the initial coordinated barrage due to heightened public awareness and the new multimedia- linked missile alert system.

After seven days, private medical facilities begin to rebound as do private and public utilities. Contract resources replace many military functions outside of missile impact ranges. The EPA handles some of the hazardous materials response under the Comprehensive Environmental Response Compensation Liability Act (CERCLA) response law while Stafford Act funds offset losses to businesses, infrastructure, and homes. The demands for CST communications abate but fire departments request prolonged CST support to supplement fire fighters recovering from weeklong shifts and sustained rescue efforts. HRF security elements remain four more days to secure impacted sites and to support other military forces already engaged in long-term border deployments. As the response efforts slow and recovery begins, HRF resources are released for future events.

While such attacks have occurred in Israel's northern cities, this depicted incident is occurring simultaneously in El Paso, Texas, and El Centro, California, as cartels hypothetically battle for control of drug and human trafficking into the U.S. cross-border violence could damage commerce in U.S. communities close to the border between Brownsville, Texas and San Diego, California. Grenades, automatic weapons, IEDs, evacuated towns, and beheadings are commonplace with cartels battling along the border. Manportable Air Defense (MANPAD) systems, land mines, advanced communication systems, mortars, unmanned air systems (UAS), frequency-hopping radios, IEDs and electronic "warfare" type systems are less prevalent but still found in the hands of cartels. While this scenario is remote, the violence in the cartel sanctuaries near the Mexican border could potentially require a type of military support similar to the Home Front Command's (HFC) employment in Israel.

## **B. RECOMMENDATIONS**

Although it is uncertain that any HRF might respond to the scenario described above, the devastation of recent earthquakes and tsunamis provide clear examples of likely natural disaster scenarios that could tax the resources of an HRF well beyond the depicted cross-border attack. Conventional military training, doctrine, and equipment cannot adequately meet the needs of the potential domestic missions the HRF will face as the nation's first military regional-level CBRNE and all-hazards response capability. Based on the experiences and the lessons provided by previous DoD and Israeli CBRNE and disaster response units, the public and elected officials will demand significant response capabilities and performance in the HRF.

### **1. Technologies and IAA**

The border scenario points to the critical need for the HRF to possess advanced technologies to support response to complex disasters or terrorist attacks. The same controversial forward thinking that provided advanced communications and technology spin-offs from the CST program should be applied to the HRF's future command, control, communication, and information systems. Feed from UAS systems, previously employed by Guard forces in floods and fires with state level consent, can enhance the HRF's situational awareness capabilities over large areas in a wide variety of response operations. Attention to intelligence oversight, proper integration of incident awareness and assessment (IAA) doctrine, and the safeguarding of American civil liberties must be integral to the HRF's employment of new technologies and systems. Intelligence oversight will become more critical as more civilian response agencies use individual Americans' cell phones, Twitter, Facebook, and other GIS-linked information to locate disaster victims, determine resource allocations, and address public-affairs concerns. Within the HRF, an IAA staff section in place of a traditional military S-2 intelligence staff can work closely with state, federal, and military legal representatives to ensure the HRF employs advanced technologies to save lives and provide a COP while avoiding

intelligence oversight pitfalls. The Army's FM 3-28, TC 2-91, and the First Air Force DSCA Air Support Handbook all provide guidance on how to employ DoD capabilities legally in the domestic environment.

## **2. Mission Scope and Flexibility**

The potential of terror attacks combined with the realities of recent disasters in Haiti and Japan also point to the need for HRFs to train on medical, SAR, and CBRNE tasks as “core capabilities” tasks that provide a basis for flexibility in responding to a wide range of missions. The original narrow CBRNE mission scope of the CST's was widened by the U.S. Congress in 2007 to allow for this type of response flexibility. The addition of a radiological component in Japan's earthquake further reinforces that many natural disasters also include CBRNE-related responses. This was evident in the dual purpose capabilities that the CST's CBRNE, laboratory, and communications capabilities brought to the space shuttle disaster and the mitigating of the hazardous materials displaced in the wake of Hurricane Katrina. The HRF's need to work closely with civilian response organizations and within civilian response standards is also clear from past CBRNE responses and integration with responders for potential significant disasters like a New Madrid Seismic Zone event.

## **3. Collaboration and Plans**

As a regional force, HRFs are designed and intended to respond across state boundaries. This specifies that HRFs must cooperate and coordinate with the state and National Guard entities within the boundaries of the 10 Federal Emergency Management Agency (FEMA) regions. Conversely, the HRF's regional National Guard and state agency partners must provide committed “pre-incident” support and cooperation to an HRF's regional planning, training, and exercise efforts. Such regional collaboration and sharing of resources is unprecedented but essential to an integrated civil-military response required by large disasters. The present regional sharing of Guard forces occurring through emergency management assistance compacts (EMAC) must now extend “pre-incident” to the new HRF to ensure regional level response success. Such collaboration will ensure the HRFs maintain both the “proximity” and utility to response

efforts that other National Guard CBRNE elements have demonstrated. External to their FEMA regions, the HRFs will have to collaborate with NORTHCOM and federal military forces responding to natural disasters or as part of DoD’s CBRN enterprise.

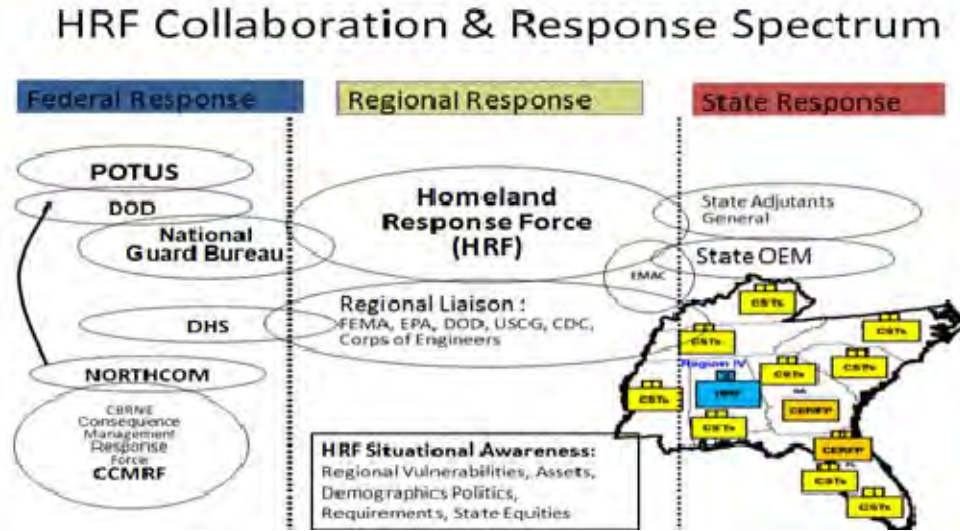

Figure 14. HRF Collaboration & Response Spectrum

Familiarity with the plans of state, federal, and DoD agencies such as U.S. NORTHCOM’s CONPLAN 3500 are another essential element of HRF collaboration. In addition to state and DoD plans, the National Contingency Plan (NCP), which was approved by President Johnson in 1968, already provides a blueprint for the nation’s CBRNE and hazardous materials response under the authorities of an appointed Federal On-Scene Coordinator (FOSC). The NCP also has a “family of plans” in the Regional Contingency Plans (RCPs) and Area Contingency Plans (ACPs) that the HRF’s can follow for CBRNE and hazardous materials response. To date the majority of NORTHCOM’s contingency plans have been used only in exercises whereas the NCP is used daily for local and national level responses. The “gap” between non-statutorily based DoD plans and the statutorily based NCP plans reflect only one challenge the HRF faces in domestic collaboration, planning, and response.

#### **4. Civil Liberties**

Concurrent with technologies, IAA and intelligence oversight concerns, National Guard leaders, and legal staff must pay due diligence to an issue as old as the U.S. itself. Civil liberty concerns always stand to inflame a broad political spectrum. The initial concern over the initial RAID title for the CSTs and the viral nature of comments made by the original CCMRF commander regarding “crowd control” reflects the sensitive and sometimes contradictory nature of domestic U.S. military employment. The types of security the National Guard and federal military forces provided successfully during the Los Angeles riots and Hurricane Katrina will be essential to future HRF missions. Still, poorly worded statements about of the HRF’s security element training with “non-lethal” packages for crowd control could pose the greatest potential public relations and political concerns for the HRF. Knowledge and appropriate employment of the HRF under the opposing Posse Comitatus and Insurrection Acts is critical to the HRF’s ability to provide timely and relevant security and life-saving support to a domestic incident.

#### **5. Examples from Israel’s Home Front Command**

Keeping mission flexibility similar to what the Israeli Home Front Command (HFC) demonstrates in meeting the demands of terrorism, rocket attacks, and natural disasters can enhance the capabilities of the HRF’s ability to provide response capability. The use of multi-media technology linked to the Color Red alert system, frequent exercises, and military support combined with close civilian cooperation represent HFC successes that the HRF can also apply. The HFC’s overseas response efforts in Turkey, Pakistan, and Haiti represent another practice that the HRFs should adopt to improve unit expertise while providing U.S. humanitarian assistance overseas. Additionally, the HFC’s ability to internalize criticisms and implement changes based upon an external document like the Winograd report reflects another “best practice” that the HRF can emulate.

### **C. CONCLUSIONS**

With 57 full-time CSTs, 17 CERFPs and now 10 HRFs, the National Guard has committed over 10,000 soldiers and airmen to domestic missions that require advanced domestic training in addition to supporting ongoing unit deployments to Iraq,



Afghanistan, Bosnia, Kosovo, and the Horn of Africa. This significant commitment of resources to both complex domestic and overseas missions must be matched with a commitment of substantial funding and training to ensure a force that can actually provide credible command and control, security, decontamination, SAR, CBRNE, and medical capabilities. Within the domestic response arena, a failure of these “advertised” capabilities could lead to reduced funding or a loss of mission. As seen in the CST and CERFP programs, Congress has played a decisive role regarding the domestic DoD CBRNE response capabilities and may contribute to the HRF’s future. With looming DoD funding reductions poor performance by the HRFs is something the National Guard can ill afford when supporting future domestic operations. As the nation’s first two HRFs become operational in the Washington and Ohio on October 1, 2011, they serve as the test platforms for an evolution in domestic-military employment and the successes of the HRF program.

With an annual budget of \$156 million, it is essential to ensure the HRF meets the demands of both regional CBRNE response and public scrutiny (National Guard Bureau, 2010). Selecting standards, technologies, and practices for an organization, which does not yet fully exist and has a new mission, are central problems in creating the 10 new HRFs. Past GAO audits, ACLU concerns, and internal DoD “push-back” demonstrate the scrutiny the HRF will face. Criticisms of the Israeli HFC in the Winograd report further demonstrate the oversight that domestic response organizations encounter. Still, DoD’s previous CBRNE organizations provide sound examples of successes that HRF leaders can follow in the creation of these new units. The institutional knowledge of these CBRNE organizations now extends back to 1996 and through thousands of successful response, support, and training missions that have occurred in every state and region.

The HRF will coordinate the regional EMAC response of CSTs and CERFPs that reside in individual states. The HRF’s unique regional mission will require greater collaboration and coordination across more federal and state entities than any previous CBRNE organizations. The HRF’s hybrid domestic and overseas requirements also present unique challenges. Operating domestically, the HRF must follow both DoD and civilian emergency response requirements and adhere to intelligence oversight laws,

while most military units simply employ “doctrine” for overseas. Through intra- and inter-regional coordination, selection of technologies capable of supporting regional command and control, use of IAA practices and appropriate civil-military standards, the HRF can capitalize on past CBRNE organizations and provide a credible suite of regional CBRNE and disaster response capabilities.

THIS PAGE INTENTIONALLY LEFT BLANK

## LIST OF REFERENCES

- Alibek, K. (1999). *Biohazard: The chilling true story of the covert biological weapons program in the world—Told from the inside man who ran it*. New York: Dell Publishing.
- Air Forces Northern. (2011). *First Air Force, Defense support to civil authorities air support handbook*. Tyndall AFB, FL: U.S. Air Force.
- Bacon, S. (2008, July 2). *U.S. Marine Corps, Chemical biological incident response force, command brief*. Retrieved November 10, 2010, from <http://www.dtic.mil/ndia/2008cbrn/Bacon.pdf>
- Blum, H. S. (2006, August 16). Presentation to the National Guard Civil Support Team Commander's Conference, Mark Hopkins Hotel, San Francisco, CA.
- Campbell, J. (2007). Headquarters for National Guard civil support teams: A homeland security imperative. *Military Review*, 87(6).
- Cavallaro, G. (2008, September 30). Brigade homeland tours start Oct. 1. *The Army Times*. Retrieved January 10, 2010, from [http://www.armytimes.com/news/2008/09/army\\_homeland\\_090708w/](http://www.armytimes.com/news/2008/09/army_homeland_090708w/)
- Chin, G. (2009, November 24). Military decision making process of the CBRNE consequence management response force and homeland response force. Internal staffing document, National Guard Bureau.
- Christensen, A. (2008, October 23) *An attack on posse comitatus*. Retrieved June 18, 2010, from [www.aclu.org/2008/10/23/an-attack-on-posse-comitatus](http://www.aclu.org/2008/10/23/an-attack-on-posse-comitatus)
- Coble, R. (2011, April 11). *Chemical, biological, radiological, nuclear (CBRN) response enterprise update to FEMA region VII homeland response force, in process review, #1*. Kansas City, MO: U.S. Northern Command.
- Department of Defense, (1993). *Military support to civil authorities* (Department of Defense Directive Number 3025.1). Retrieved June 12, 2010, from <http://www.dtic.mil/whs/directives/corres/pdf/302501p.pdf>
- Department of Homeland Security. (2003). *Homeland security presidential directive five: The management of domestic incidents*. Retrieved June 12, 2010, from [http://www.dhs.gov/xabout/laws/gc\\_1214592333605.shtm](http://www.dhs.gov/xabout/laws/gc_1214592333605.shtm)
- Department of Homeland Security. (2008, December). *National incident management system*. Washington, DC: author.

- Department of Homeland Security. (2008, January). *National response framework*. Washington, DC: author.
- Department of Homeland Security. (2003). *Department of Homeland Security homeland security directive 8: national preparedness*. Retrieved January 5, 2010, from [http://www.dhs.gov/xabout/laws/gc\\_1215444247124.shtm](http://www.dhs.gov/xabout/laws/gc_1215444247124.shtm)
- Gereski, J. (2010, September 27). *Legal aspects of defense support to civil authorities*. Presentation at the Center for Homeland Defense and Security, Naval Postgraduate School, Monterey, CA.
- Giambastiani, E. (2006, August 17). Chemical biological, radiological, nuclear and high yield explosive emergency response force package DOTMLPF changes. Internal document, Department of Defense, Washington, DC.
- Greenhill, J. (2007, December 13). Guard learns from a city under fire. *Army News Service*. Retrieved August 15 2010 from <http://www.military.com/features/0,15240,158180,00.html>
- Huboba, F. & Reese, M. (2007, September). National Guard consequence management capabilities. Internal document, National Guard Bureau J/3 Domestic Operations.
- Headquarters, Department of the Army. (2009). *Field manual 3-28: Civil support operations*. Leavenworth, KS: author.
- Headquarters, Department of the Army. (2009). *Training circular 2-91.501: Intelligence handbook for civil support operations*. Fort Huachuca, AZ: author.
- Israel Defense Force. (n.d. a). *Home Front Command: History*. Retrieved August 14, 2010, <http://dover.idf.il/IDF/English/units/pikudim/homefront/History>
- Israel Defense Force. (n.d. b). *Home Front Command*. Retrieved August 1, 2010, from <http://www.oref.org.il/502-1706-en/PAKAR.aspx>
- Jones, A. (2004, May 26). Guidance to the Army G-3 (Operations) and the Chief of National Guard Bureau, on the National Guard CBRNE enhanced response force packages (CERFP). Internal document, United States Army Training and Doctrine Command, Fort Monroe, VA.
- Leyden, J. (2010 May 24). Israel Defense Forces IDF Home Front Command exercise turning point 4. *Israeli New Agency*. Retrieved August 13, 2010, from <http://www.freerepublic.com/focus/f-news/2519789/posts>
- Miller, J., Engelberg S., & Broad, W. (2001). *Germs: Biological weapons and America's secret war*. New York: Simon and Shuster.

- Nash, M. (2002, November 24). In person: Where terrorism meets optimism. *New York Times*. Retrieved June 12, 2010, from <http://www.nytimes.com/2002/11/24/nyregion/in-person-where-terrorism-meets-optimism.html>
- National Guard Bureau & U.S. Northern Command. (2010, August 17–19). *Homeland response force and CBRN enterprise presentation*. National Guard Bureau and NORTHCOM CBRNE Planning Workshop, Kansas City, MO.
- Office of Inspector General, Department of Defense. (2001, May 1). *Statement of Robert J. Lieberman, Deputy Inspector General, to the Subcommittee on Emerging Threats and Capabilities, Senate Armed Services Committee on National Guard Weapons of Mass Destruction, Civil Support Team* (Report Number D-2001-113). Washington, DC: author.
- Office of the Federal Register National Archives and Records Administration. (2009). *National oil and hazardous substances pollution contingency plan*. Washington, DC: U.S. Government Printing Office.
- National Fire Protection Association. (2008). *NFPA 472: Standard for competence of responders to hazardous materials/weapons of mass destruction incidents*. Quincy, MA: author.
- Office of the Director of National Intelligence. (2007). *U.S. Intelligence community legal reference book*. Washington, DC: author.
- Office of the Secretary of Defense, Department of Defense. (2009a). *Alternatives to the CBRNE Consequence Management Response Force (CCMRF)*. Internal document.
- Opall-Rome, B. (2009, January 19). In Israel: Anti-sniper gear spots rockets. *Defense News*. Retrieved August 18, 2010, from <http://www.defensenews.com/story.php?i=3907655>
- Preston, R. (1998). *The cobra event*. New York: Random House.
- Preston, R. (1994). *The hot zone: A terrifying true story*. New York: Random House.
- Raday F. (2006, August 20). *Israel under rocket attack: A profile of displacement and destruction, 12 July–15 August 2006*. New York: Jacob Bluestein Institute for the Advancement of Human Rights of the American Jewish Committee.
- Sims, J. & Gerber, B. (2005). *Transforming US intelligence*. Washington, DC: Georgetown University Press.

- Tahlequah Daily Press. (2007, June 1). *Insurrection act recipe for weaker states*. Retrieved February 16, 2010, from <http://tahlequahdailypress.com/archive/x519333515/print>
- U.S. Army, Center for Lessons Learned. (2009). *Civil support and the U.S. Army: Tactics, techniques, and procedures* (No. 10-16). Leavenworth, KS: author.
- U.S. Congress. (1807). *USC Title 10, Chapter 15—Insurrection Act*. Retrieved January 20, 2010, from [http://www4.law.cornell.edu/uscode/10/usc\\_sup\\_01\\_10\\_10\\_A\\_20\\_I\\_30\\_15.html](http://www4.law.cornell.edu/uscode/10/usc_sup_01_10_10_A_20_I_30_15.html)
- U.S. Congress. (1878). *USC Title 18, Section 1835—Use of Air Force and Army as posse comitatus*. Retrieved January 20, 2010, from [http://www.law.cornell.edu/uscode/18/usc\\_sec\\_18\\_00001385----000-.html](http://www.law.cornell.edu/uscode/18/usc_sec_18_00001385----000-.html)
- U.S. Department of Labor, Occupational Safety and Health Standards. (n.d.). *Hazardous waste operations and emergency response, 29 Code of Federal Regulations 1910.120*. Retrieved January 5, 2010, from [http://www.osha.gov/pls/oshaweb/owadisp.show\\_document?p\\_table=standards&p\\_id=9765](http://www.osha.gov/pls/oshaweb/owadisp.show_document?p_table=standards&p_id=9765)
- U.S. Government Accountability Office. (2006). *Homeland Defense: National Guard Bureau needs to clarify Civil Support Teams' mission and address management challenges* (GAO-06-498). Retrieved June 12, 2010, from <http://www.gao.gov/products/GAO-10-123>
- U.S. Government Accountability Office. (2009). *Homeland defense: planning, resourcing, and training issues challenge DoD's response to domestic chemical, biological, radiological, nuclear, and high-yield explosives* (GAO-10-123). Retrieved June 12, 2010, from <http://www.gao.gov/products/GAO-06-498>
- U.S. Senate. (1976). *Book VI: United States Senate Select Committee to Study Governmental Operations with Respect to Intelligence Activities*. Washington DC: U.S. Government Printing Office.
- U.S. Army Training and Doctrine Command. (2009, October 23), Order to the maneuver support center (manscen) to “cease work” on the CCMRF. Internal document.
- U.S. Congress, (2006, January 6). *National Defense Authorization Act for Fiscal Year 2007*.
- U.S. Congress. (1980, December 11). *The Comprehensive Environmental Response, Compensation, and Liability Act (CERCLA)*. Retrieved on September 14, 2010, from <http://www.epa.gov/superfund/policy/cercla.htm>

- U.S. Congress (2007). *National Defense Authorization Act for Fiscal Year 2007*. Retrieved September 14, 2010, from <http://www.gpoaccess.gov/serialset/creports/ndaafy07.html>
- White House. (1995). *Presidential decision directive 39: U.S. policy on counterterrorism*. Retrieved September 30, 2010, from <http://www.epa.gov/radiation/rert/presidentialdirectives.html#pdd39>
- White House (1998a). *Presidential decision directive 62: Protection against unconventional threats to the homeland and Americans overseas*. Retrieved September 30, 2010, from <http://www.epa.gov/radiation/rert/presidentialdirectives.html#pdd62>
- White House. (1998b). *Presidential decision directive 63: Critical infrastructure protection*. Retrieved September 30, 2010, from <http://www.epa.gov/radiation/rert/presidentialdirectives.html#pdd63>
- Winograd, E. (2008, January 30). *Commission final report: press conference of Judge Eliyahu Winograd*. Retrieved August 14, 2010, from <http://www.jewishvirtuallibrary.org/jsource/Winograd>



THIS PAGE INTENTIONALLY LEFT BLANK

## **INITIAL DISTRIBUTION LIST**

1. Defense Technical Information Center  
Ft. Belvoir, Virginia
2. Dudley Knox Library  
Naval Postgraduate School  
Monterey, California