



# NAVAL POSTGRADUATE SCHOOL

MONTEREY, CALIFORNIA

## THESIS

**IDENTIFYING THE METHOD FOR EFFECTIVE COMBAT  
MARKSMANSHIP TRAINING USING SITE OPTICS AND  
PACKAGED SENSOR FEEDBACK**

by

Gabriel D. Diaz

September 2011

Thesis Co-Advisors:

William Becker

Antony Ciavarelli

Second Reader:

Christian Smith

**This thesis was performed at the MOVES Institute  
Approved for public release; distribution is unlimited**

THIS PAGE INTENTIONALLY LEFT BLANK

REPORT DOCUMENTATION PAGE			Form Approved OMB No. 0704-0188	
Public reporting burden for this collection of information is estimated to average 1 hour per response, including the time for reviewing instruction, searching existing data sources, gathering and maintaining the data needed, and completing and reviewing the collection of information. Send comments regarding this burden estimate or any other aspect of this collection of information, including suggestions for reducing this burden, to Washington headquarters Services, Directorate for Information Operations and Reports, 1215 Jefferson Davis Highway, Suite 1204, Arlington, VA 22202-4302, and to the Office of Management and Budget, Paperwork Reduction Project (0704-0188) Washington DC 20503.				
1. AGENCY USE ONLY (Leave blank)		2. REPORT DATE September 2011	3. REPORT TYPE AND DATES COVERED Master's Thesis	
4. TITLE AND SUBTITLE Identifying the Method for Effective Combat Marksmanship Training Using Site Optics and Packaged Sensor Feedback			5. FUNDING NUMBERS	
6. AUTHOR(S) Gabriel D. Diaz				
7. PERFORMING ORGANIZATION NAME(S) AND ADDRESS(ES) Naval Postgraduate School Monterey, CA 93943-5000			8. PERFORMING ORGANIZATION REPORT NUMBER	
9. SPONSORING /MONITORING AGENCY NAME(S) AND ADDRESS(ES) N/A			10. SPONSORING/MONITORING AGENCY REPORT NUMBER	
11. SUPPLEMENTARY NOTES The views expressed in this thesis are those of the author and do not reflect the official policy or position of the Department of Defense or the U.S. Government. IRB Protocol number NPS.2001.0094-IR-EP7-A				
12a. DISTRIBUTION / AVAILABILITY STATEMENT Approved for public release; distribution is unlimited			12b. DISTRIBUTION CODE A	
13. ABSTRACT (maximum 200 words)  The Marine Corps is assessing how shooters train for Combat Marksmanship. An implementation of the Rifle Combat Optics (RCO) has been introduced into the Annual Rifle Qualification requirement. The question now is, How do coaches modify training to effectively instruct the shooters in firing with the RCO? This study provides feedback using the Split Shot Scope System as an aid in training doctrinal techniques for marksmanship on live fire ranges. The assessments, provided by current Marine Corps Marksmanship Instructors, highlight a necessity to using a device such as the Split Shot Scope System. In a postsurvey conducted in the study, responses provide a viable path to employing this diagnostic tool during live fire shooting and reporting the level of utility of this device. Added, in this study, is the use of a sensor package derived from concepts of the Indoor Simulated Marksmanship Trainer (ISMT), which will be discussed to provide the utility of such a device for improving and defining a useful technique for training shooters. While this may not be a complete fix to the dilemma, this study has provided an approach to understanding and deriving methods for effective marksmanship training and diagnosing fundamental problems more clearly.				
14. SUBJECT TERMS Marksmanship, Optics, Remote Sensors, Shooting, Simulation, Rifle, Weapons, Training			15. NUMBER OF PAGES 89	
			16. PRICE CODE	
17. SECURITY CLASSIFICATION OF REPORT Unclassified	18. SECURITY CLASSIFICATION OF THIS PAGE Unclassified	19. SECURITY CLASSIFICATION OF ABSTRACT Unclassified	20. LIMITATION OF ABSTRACT UU	

NSN 7540-01-280-5500

Standard Form 298 (Rev. 8-98)  
Prescribed by ANSI Std. Z39.18

THIS PAGE INTENTIONALLY LEFT BLANK

**Approved for public release; distribution is unlimited**

**IDENTIFYING THE METHOD FOR EFFECTIVE COMBAT MARKSMANSHIP  
TRAINING USING SITE OPTICS AND PACKAGED SENSOR FEEDBACK**

Gabriel D. Diaz  
Captain, United States Marine Corps  
B.S., Naval Postgraduate School, 2011

Submitted in partial fulfillment of the  
requirements for the degree of

**MASTER OF SCIENCE IN  
MODELING, VIRTUAL ENVIRONMENTS, AND SIMULATION (MOVES)**

from the

**NAVAL POSTGRADUATE SCHOOL  
SEPTEMBER 2011**

Author: Gabriel D. Diaz

Approved by: William Becker, PhD  
Thesis Co-Advisor

Anthony Ciavarelli, PhD  
Thesis Co-Advisor

Christian (Kip) Smith  
Second Reader

Mathias Kölsch  
Chair, MOVES Academic Committee

Peter Denning  
Chair, Computer Science Department, GSOIS

THIS PAGE INTENTIONALLY LEFT BLANK

## **ABSTRACT**

The Marine Corps is assessing how shooters train for Combat Marksmanship. An implementation of the Rifle Combat Optics (RCO) has been introduced into the Annual Rifle Qualification requirement. The question now is, How do coaches modify training to effectively instruct the shooters in firing with the RCO? This study provides feedback using the Split Shot Scope System as an aid in training doctrinal techniques for marksmanship on live fire ranges. The assessments, provided by current Marine Corps Marksmanship Instructors, highlight a necessity to using a device such as the Split Shot Scope System. In a postsurvey conducted in the study, responses provide a viable path to employing this diagnostic tool during live fire shooting and reporting the level of utility of this device. Added, in this study, is the use of a sensor package derived from concepts of the Indoor Simulated Marksmanship Trainer (ISMT), which will be discussed to provide the utility of such a device for improving and defining a useful technique for training shooters. While this may not be a complete fix to the dilemma, this study has provided an approach to understanding and deriving methods for effective marksmanship training and diagnosing fundamental problems more clearly.

THIS PAGE INTENTIONALLY LEFT BLANK



## TABLE OF CONTENTS

I.	INTRODUCTION.....	1
A.	PROBLEM STATEMENT.....	2
B.	MOTIVATION.....	3
C.	RESEARCH QUESTION.....	6
II.	BACKGROUND.....	9
A.	MARINE CORPS MARKSMANSHIP TRAINING PROGRAM.....	9
B.	MARKSMANSHIP FUNDAMENTALS.....	10
1.	Aiming.....	12
2.	Breath Control.....	13
3.	Trigger Control.....	13
4.	Muscle Relaxation and Natural Point of Aim.....	14
C.	CURRENT COMBAT MARKSMANSHIP TRAINING PROCEDURES.....	14
D.	RELATED RESEARCH.....	16
1.	Simulation Training.....	17
2.	Motion Capture.....	21
E.	OTHER SOURCES.....	23
1.	Process of Refining Necessary Variables.....	23
2.	Tutoring and Learning.....	24
3.	Packaged Sensor Feedback.....	25
III.	METHODOLOGY FOR EXPERIMENT.....	29
A.	EXPERIMENT WITH REMOTE COMBAT OPTICS.....	31
1.	Purpose.....	31
2.	Subjects.....	31
3.	Procedures.....	32
B.	SPECIFICATION OF THE SPLIT SHOT SYSTEM.....	33
C.	CURRENT SUSTAINMENT TRAINING PROCEDURES.....	34
1.	Table 1 KD Course.....	34
2.	200 Yard Line.....	36
3.	300 Yard Line.....	38
4.	500 Yard Line.....	39
5.	Table 2 KD Course.....	40
6.	Table 3 KD Course.....	41
7.	Table 4 KD Course.....	42
8.	Remote Combat Optics (RCO) Instruction.....	42
a.	<i>RCO Fundamentals</i> .....	43
IV.	RESULTS.....	49
A.	SUMMARY OF FINDING FOR THE SLIT SHOT SCOPE TRANSMITTER.....	49
V.	CONCLUSION AND RECOMMENDATION.....	57

A.	OBSTACLES AND TECHNICAL DIFFICULTIES.....	57
B.	TRAINING OUTCOMES AND RECOMMENDATIONS .....	59
C.	FUTURE WORK.....	60
APPENDIX A.	TABLE 1 KNOWN DISTANCE COURSE .....	63
APPENDIX B.	DEMOGRAPHICS QUESTIONNAIRE/ POSTSURVEY (SHOOTERS) .....	65
APPENDIX C.	DEMOGRAPHICS QUESTIONNAIRE/POSTSURVEY (SUBJECT MATTER EXPERTS) .....	67
	LIST OF REFERENCES.....	69
	INITIAL DISTRIBUTION LIST .....	73

## LIST OF FIGURES

Figure 1.	SIGHT PICTURE (From NAVMC 42, 2011) .....	12
Figure 2.	SIGHT ALIGNMENT (From NAVMC 42, 2011) .....	13
Figure 3.	ISMT (From Marine Corps website, 2011).....	18
Figure 4.	ISMT Sensor Chart (From Becker, 2010).....	21
Figure 5.	Sensor Components (From Becker, 2010).....	26
Figure 6.	Sensor Components (From Becker, 2010).....	27
Figure 7.	Sensor Feedback Interface (From Becker, 2010).....	28
Figure 8.	Split Shot Scope Transmitter (From Tactical Electronics, 1999) .....	30
Figure 9.	Split Shot Scope Mounted (From Tactical Electronics, 1999).....	30
Figure 10.	Split Shot Scope and Monitor (From Tactical Electronics, 1999).....	34
Figure 11.	“A” TARGET (From NAVMC 42, 2011).....	37
Figure 12.	“D” TARGET (From NAVMC 42, 2011) .....	38
Figure 13.	“B” TARGET (From NAVMC 42, 2011).....	39
Figure 14.	Scope Shadow (From TBS Marksmanship Student Outline, 2011)....	43
Figure 15.	RCO Reticle Pattern (From TBS Marksmanship Student Outline, 2011) .....	44
Figure 16.	Aiming Sight Picture at 100 Yards (From TBS Marksmanship Student Outline, 2011).....	45
Figure 17.	Reticle Sight Picture at 200 Yards (From TBS Marksmanship Student Outline, 2011).....	45
Figure 18.	Reticle Sight Picture at 300 Yards (From TBS Marksmanship Student Outline, 2011).....	46
Figure 19.	Reticle Sight Picture at 500 Yards (From TBS Marksmanship Student Outline, 2011).....	46
Figure 20.	Post Question 6 (In comparison, did you find it easier to coach the shooter using the live video feedback than shooters not using the video feedback?) .....	50
Figure 21.	Experienced Coaches response to whether or not they found it easier to instruct using the Split Shot Scope Transmitter .....	50
Figure 22.	Post Question 7 (How much time did you find yourself spending on the shooter with the live video feedback than the other shooters not using the video feedback?).....	51
Figure 23.	Experienced coaches response to whether they found themselves spending more, less or equal time with the Split Shot Scope Transmitter coaching shooters .....	52
Figure 24.	Post Question 8 (Do you feel the optical video feedback device was useful in aiding your coaching with the RCO?).....	53
Figure 25.	Experienced Coaches response to Usefulness of System .....	53
Figure 26.	Post Question 9 (Do you feel that using video feedback on the RCO eliminated some unknown factors and made it easier to focus your coaching of the shooter in other areas?) .....	54

Figure 27. Experienced Coaches response to whether they found it easier to coach shooter given the system eliminated some unknown factors ... 55

## LIST OF ACRONYMS AND ABBREVIATIONS

BZ0	Battle-Sight Zero
CMC	Combat Marksmanship Coach's Course
CMS	Combat Marksmanship Symposium
EST	Engagement Skills Trainer
FMFM	Fleet Marine Force Manual
ISMT	Indoor Simulated Marksmanship Trainer
KD	Known Distance
MCDP	Marine Corps Doctrine Publication
MCO	Marine Corps Order
MCRD	Marine Corps Recruit
MOVES	Modeling Virtual Environments and Simulation Institute
NPS	Naval Postgraduate School
OCS	Officer Candidate School
RCO	Rifle Combat Optics
ROP	Record Of Proceedings
TBS	The Basic School
WTBn	Weapons Training Battalion

THIS PAGE INTENTIONALLY LEFT BLANK

## ACKNOWLEDGMENTS

I wish to thank those that have provided guidance and support in my endeavors to complete this study. First, I wish to thank Weapons Training Battalion in Quantico, VA for their support on a last minute notice. Their professionalism and enthusiasm in the willingness to sacrifice their time and efforts to be part of studies that promote advancement in marksmanship are truly appreciated. Secondly, Terry Norbraten and Brooks Lamé, for their encouragement and technical support in the systems used for this study. Their direction and selflessness has greatly provided me with the opportunity to creatively design this study and talk through the direction of the work. Tony Ciavarelli (Dr. C), whom I can't thank enough for the knowledge in Human Factors and the direction that has so greatly provided me with structure. His mentorship and most gracious enthusiasm to continue to support my work from afar has surpassed expectations. Thanks to Kip Smith and his direction, along with tiresome assignments, without them I could have not obtain the clear direction in conducting this study. My thesis advisor, Bill Becker, for his willingness to take me on as a thesis student. His support and patience in my work has truly been a blessing. Without his mentorship, my efforts would have been in limbo. Lastly, I want to thank my lovely wife, Kimberly, for putting up with me on stressful days, and her patience during the late nights needed for me to complete not only this thesis, but also my class work in the process. My two sons, Trentin and Devin, for understanding their dad could not make every game, though I tried. This evolution has truly been an experience.

THIS PAGE INTENTIONALLY LEFT BLANK



## I. INTRODUCTION

The Marine Corps' motto, "Every Marine is a rifleman," has withstood the sands of time. The Marine Corps has always taken pride ensuring the basic Marine is trained to the best capable shooter possible. Every Marine is trained to effectively operate all weapons of issue within their command (Marine Corps Order MCO 3574.2K, 2007). The most basic weapon in today's Marine Corps arsenal is the M-4 carbine. The M-4 carbine is the next-generation rifle currently issued to Marines for combat marksmanship. While the M-16 A2 and A4 service rifles are still provided and in use, they are slowly transitioning out of armories and replaced with the M-4.

The M-4 rifle was issued in response to the close-quarter combat that most Marines encountered in recent wars. This weapon provides the ability to easily maneuver in small areas, especially while conducting room clearings, all the while still providing the ability to effectively hit a far-distant target of ranges up to, but limited to, 500 yards. This rifle is currently the standard issued weapon for the Marine Corps. Though advancements in weaponry are aimed at providing the best capabilities possible, there still exists a gap in effectively training users in the operation of these weapons—the rifle cannot hit a target by itself without some human interaction in the process. Additionally, the use of iron sights for annual rifle qualification is becoming a thing in the past. The Marine Corps has chosen to train using the Rifle Combat Optics (RCO), a scope used in place of the iron sights, and moving toward only qualifying with the RCO. The RCO puts an added variable of uncertainty when coaches attempt to instruct shooters on refining skills and techniques. So an attempt to eliminate, or simplify, certain behaviors that might be known to contribute to the troubles of achieving high performance, may be a possible solution to mitigating the frustration of the trial and error approach to marksmanship training.

The Marine Corps invests greatly in training the Marine fighter to ensure it maintains the highest standard of professionalism and success in combat. Marines are required to master “the techniques and procedures that contribute to the development of warfighting skills such as marksmanship, navigation, gunnery, and close air support. The execution of these techniques and procedures must become second nature for all Marines; meeting this goal requires intensive and continuous training. Without mastery of basic warfighting skills, artistry and creativity in their application are impossible” (Krulak,1997).

As the world continues with multiple war campaigns, and with the operational tempo still at an ultimate high, time to train in order to prepare for combat is becoming only a memory. Deployment rotations are overlapping, time to dwell at home is shorter than projected, and effective professionals of warfare are getting less and less time behind the gear to train. Marines, as well as other U.S. Armed Services, need not only the time to train, but also need an effective way to maximize training in the time allotted.

## **A. PROBLEM STATEMENT**

So the question now is not how can more time allotted to train, nor is it a question of whether or not practice will make perfect, because this study is not just about practice. The study should be about the most effective way to assist trainers, instructors, and coaches to ensure they can best identify the weakness of a shooter and focus training based from those collected observations.

As mentioned earlier, the Marine Corps is currently implementing the use of the RCO for annual rifle qualification. The problem is understanding what method of instruction and coaching is most effective. In the Combat Marksmanship Symposium (CMS) Record Of Proceedings (ROP) conducted in March of 2011, the Marine Corps determined to order the conduct of RCO testing for Entry Level Training (ELT). With this order, questions were asked whether there is an advantage to training with the RCO or with iron sights. Since the RCO is currently employed in combat zones and used in U.S. Marine Corps

Marksmanship Training tables three and four, the intentions are that it would not be must of a stretch to begin ELT of the RCO from the start—but would this be effective? Table three (3) and four (4) are part of the annual training requirements for marksmanship training but is not a scored event. Table 3 consist of engaging targets under more realistic situations than the Tables 1 and 2 that are typically at the start of training. Table 4 is an extended version of Table 3 complimenting the training by having the shooter conduct movement and pivoting demonstration for engagement of target. (More is discussed on the tables of the Known Distance (KD) course of fire later in Chapter II). RCO training is meant to enhance the shooter's ability to accurately engage targets and to make the use of the RCO as normal as the iron sights have become. Simplicity and clear direction in training shooters needs to be the focus by ensuring that the shooter and marksmanship coach alike apply the techniques and procedures of proper marksmanship in RCO training.

General Krulak, former Commandant of the Marine Corps and author of Marine Corps Doctrine Publication (MCDP) 1–3, (1997) mentions

Good tactics depend upon sound technical skills. These are the techniques and procedures that enable us to move, shoot, and communicate. We achieve technical competence through training. We build skills through repetition. Training also instills confidence in weapons and equipment. One of the ultimate aims of training is speed. Essential to speed is the requirement for accuracy. Speed without accuracy may be counterproductive and causes more damage than inaction. Whether Marines compute firing data, practice rifle marksmanship or weapons gunnery, rearm and refuel aircraft, repair vehicles, stock or transport supplies, or communicate information, the speed and accuracy of their actions determine the tempo of the overall force. Training develops the proficiency which enables this effective combination of speed and accuracy (p. 117).

## **B. MOTIVATION**

In the past fifteen years the Marine Corps has modified its approach multiple times to qualifying on the Known Distance Course for sustainment training. The initial concept was to maintain the established form of qualifying by

using the 0–250 point system. This method has been in current employment in both Marine Corps Recruit Depot training facilities and the Marine Corps Officer Candidate School (OCS). The next approved approach was to change the point system to cover 0–65. From the author’s personal experience, this method made it easier for most shooters, who already demonstrated high proficiency levels, to qualify expert at the completion of the 200 yard firing line and allowing other less skilled shooters to qualify at the lowest level as marksman at the same distance. This approach created a huge discrepancy in ensuring that shooters were demonstrating acceptable levels of proficiency at the 300- and 500-yard firing lines. Most Marines were only concerned with the level of their score in order to obtain promotion points toward their next rank. To add insult to injury, consecutive qualified experts were allowed to forego shooting and claim their last qualification score as a waiver to fulfilling annual requirements. Though these shooters were mandated to fire the following annual requirement, it added a larger training gap to an already limited exposure of weapons training. The Marine Corps then decided to revert to the original method of qualification. To qualify as marksman, Marines will need to score between a 190 to 209, a 210 to 219 for sharpshooter and an expert needs 220. The Marine Marksmanship training only allows the shooters to receive two days of live fire training, one of those days being the pre-qualification stage. On the third day the shooters fire for qualification. The approach would give less time for Marines not working or maintained in a military occupational skill that requires the primary use of a weapon. If the Marine Corps is changing the way Marines conduct weapons training for combat, then there needs to be an approach that is most effective to ensuring that these changes in training will not affect the utility of training and degrade the level of proficiency in marksmanship?

Technology is susceptible to Moore’s law, and has provided an increased technological capability that has enhanced the experience of simulations (Scribner, Wiley, & Harper, 2007). After recognizing that the Modeling Virtual Environments and Simulation (MOVES) Institute at the Naval Postgraduate

School (NPS) maintains an operational Indoor Simulated Marksmanship Trainer (ISMT), an exact replica of what the Marine Corps maintains throughout its installations, there opened a door to learning what techniques work best in marksmanship training. Problems associated with the current use of ISMT have led to a lack of trust in the simulator. Therefore, this thesis' author raised the question, Why not derive a method that will enhance ISMT involvement in training to better assist instructors to coach shooters? ISMT is a training simulator with life-size screens displaying computer generated images for scenarios on engaging realistic targets and providing a virtual Known Distance course for training shooters. It simulates realistic audio and video feedback, as well as haptic feedback in the form of recoil when the shooter fires a weapon in the trainer. ISMT was created to provide weapons training support to shooters that needed more practice. This enables shooters to take advantage of an enhanced “snap-in time” 24 hours a day. Snap-in is a process of a shooter taking the time to obtain a comfortable posture in different firing positions and practice all mental and physical motions of firing the weapon, such as reloading, pulling the trigger, and obtaining proper sight alignment and sight picture, without actually having a round (bullet) in the chamber of the weapon.

In a previous study, conducted by Army majors William L. Platte and Johnny J. Powers, the discussion was aimed at identifying qualities of an expert shooter. More narrowly speaking, “If these qualities are clearly identifiable why has there not been an effort to record and visually display what ‘right’ looks like?” (2008). The study used the use of the Army’s Engagement Skills Trainer (EST) that currently has features mirrored within the ISMT. So this study has prompted a curiosity to using ISMT and determining not one single profile but rather to use common characteristics (variables) that are valued at different levels for each shooter based from their individual performance and shooting habit—unique profiles for each shooter.

### **C. RESEARCH QUESTION**

The effectiveness of training with ISMT is not only a function of the quality of the simulation, but also depends upon how the simulator is used. In other words, the training outcome depends upon the instruction provided too. This thesis will address an approach on how best to use the ISMT from the standpoint of effective instruction and simulation.

Is there an effective method for aiding marksmanship coaches using live video feedback and instantaneous sensor feedback during live fire training?

By identifying proper training procedures, in and out of virtual environments, that focusing on techniques to engage targets, and teach effective combat marksmanship training at the basic level, ISMT can become a system of reliable use. The need to break down the details of what is required to effectively utilize ISMT and enhance the learning experience will in turn provide positive training transfer to the real world.

The intent of this study is to identify a method for instruction, by using the Marine Corps' doctrinal publications for weapons training as a guide, and compare it to the training currently used by marksmanship instructors in the Marine Corps. The intentions of this derived method is to provide quality instruction using ISMT as a compliment for training by range coaches, and foremost, using the capabilities of a wireless remote camera allowing coaches to instantaneously view through the scope of the shooter through a handheld device. This effort aims at improving the shooter's technique and success, after instruction, in the completion of the KD Course of fire. Only Table 1 of the training evaluation scenario will be used to determine a final score for each shooter and to gather data that will assist not only in the face validation of the video feedback package, but also in addressing potential variables used for the sensor package to derive a method of instruction that will not use simulated scores as a guideline for improvement. The scores collected will be compared between shooters of the test group and control group on the KD Course for rifle qualifications by means of

the current scoring system (score card) for each stage of fire within Table 1. (See Appendix D for the Table 1 Marksmanship Training doctrine.)

THIS PAGE INTENTIONALLY LEFT BLANK



## **II. BACKGROUND**

### **A. MARINE CORPS MARKSMANSHIP TRAINING PROGRAM**

The Marine Corps builds the shooter to a level of proficiency through a four-stage training evolution (Combat Marksmanship Course, 2006). This bottom-up process begins at Marine Corps basic training and is continued throughout the service time of the Marine. From the beginning, a shooter is taught the basic rifle handling procedures from the standpoint that the Marine has never fired a weapon. These techniques are aimed at ensuring that every Marine receives and demonstrates the same basic fundamentals required to become an effective marksmanship shooter.

The Marine Corps trains its shooters using a five stage process. This technique remains the same throughout the Marine's career. Marine recruits, at both Marine Corps Recruit Depot (MCRD) San Diego, California and Marine Corps Recruit Depot (MCRD) Paris Island, South Carolina, receive their first and most important training on basic fundamentals of marksmanship aimed to provide the Corps with effective shooters.

In the preparatory phase (stage I) of marksmanship training, all Marines, recruits included, receive periods of instruction in the form of classroom lectures, demonstrations and practical application. This allows them to focus on understanding the procedures and rules of shooting, both on and off the Marine firing ranges, in order to confidently employ the weapon in a combat situation. It also allows the shooters to mentally prepare themselves for employing the weapons for which they are receiving instruction. While the classes are given, shooters become familiarized with their weapon. They are given hands-on classes on the maintenance, handling and operations of the weapon. During this preparatory phase, shooters practice the fundamental handling of the weapons as well as practicing different stances for engagement at the next stage.

Shooters currently conduct a series of dry-fire drills to allow the shooter to practice proper trigger squeeze and eliminate anticipation of the round being fired.

Once the shooters complete this part of the training they proceed training for follow-on evaluation of performance employing the weapon. Shooters must complete and pass Table 1 (stage II) and Table 2 (stage III) of the Known Distance (KD) Course. Table 1 allows the range coaches and shooters to identify and correct techniques of marksmanship fundamental (Combat Marksmanship Course, 2006). The purpose of Table 1 is to establish that the shooter has mastered a level of marksmanship proficiency at the fundamental level by engaging static targets at a known distance from 200, 300 and 500 yards (Marine Corps Order MCO 3574.2K, 2007). Each stage of firing prepares the shooters for the follow-on stages—Basic Combat Marksmanship (Table 2), Intermediate Combat Marksmanship, Table 3 (stage IV) and Advanced Combat Marksmanship, Table 4 (stage V). The purpose of Table 2 is to establish a fundamental level of proficiency by demonstrating the ability to engage targets of limited exposure, engaging targets during low light and darkness, engaging targets while wearing a field protective mask, engaging multiple targets, engaging moving targets, and engaging moving targets at unknown distances (Fleet Marine Force Manual FMFM 0–9, 1995). This study completed in this thesis consists of identifying a technique of training at the fundamental level of marksmanship.

## **B. MARKSMANSHIP FUNDAMENTALS**

The study of marksmanship performance at the fundamental level is one of the main areas of interest for the military. Studies have been aimed at not only providing analysis on training systems designed to provide this assistance, but also studies on how to improve the way we use these systems and how to best learn to employ them. The Marine Corps teaches entry-level marksmanship through known methods that have been deemed effective. Identifying

characteristics of marksmanship has enabled shooting instructors to establish a series of building blocks that are later applied in more complex situation or surroundings. This way acquisition of improved skills can take place without needing to reiterate, or train, the basics again. This provides less clutter to the shooter when learning more advanced techniques, therefore, some lectures, though sometimes necessary, are omitted with the understanding that the fundamentals have been recently taught and not depreciated. Every Marine undergoes the fundamentals each time they qualify for annual sustainment. In this circumstance, it is necessary to reiterate the basics because of the diminished time spent for marksmanship training due to operational tempo. Shooters will usually qualify only once a year, other than that, they never practice shooting the KD Course on a regular basis. This method of marksmanship training is standard operating procedures for the Marine Corps regardless of their jobs, but, there are times where an abridged technique may be used for shooters where their weapons are part of their daily course of work. The infantry, for example, employ their carbine weapons on a daily basis, so their ability to operate and engage targets would be more advanced compared to other daily jobs in the military.

Marksmanship fundamentals address how to maintain proper breath control, muscle relaxation, bone support, natural point of aim, sight picture and sight alignment. The shooter needs to also understand proper trigger pull, weapons cant, eye relief, the correct placement of the forward hand, the proper elevation and wind-age adjustments and necessary calculations necessary for accurate shooting (Combat Marksmanship Coach's Course CMC.20, 2006).

The Marine Corps has used the FMFM 0-9 (1995) as a guide to training shooters. Shooters begin learning the cognitive fundamentals of marksmanship training beginning with the introduction of the "Combat Mindset." This period of instruction addresses to the shooter to affects of a stressful situation and to become aware of their situation in order to remain focused. The next level of introduction incorporates learning the detailed features of the weapon. Shooters

learn how to maintain and handle their weapon. This incorporates the mental skills needed to respond to changes in the weapon's condition and cycle of operation and learning how to deal with uncontrollable variables such as weather. The most important part of the skills to be learned are the fundamentals of marksmanship training. Once these skills are learned they follow-on to the next stage, which is going through the motor skills of employing these fundamentals accurately (1995).

## 1. Aiming

Shooters learn how to aim in on a target. They learn the process of what it means to have sight picture and sight alignment. Sight picture is the knowing what should be in focus and what should remain as a blur while keeping the top of the front sight post centered on the target, referenced in Figure 1. Sight alignment is ensuring that the front sight aiming post and the rear sight aperture are properly aligned and centered accurately, referenced in Figure 2.

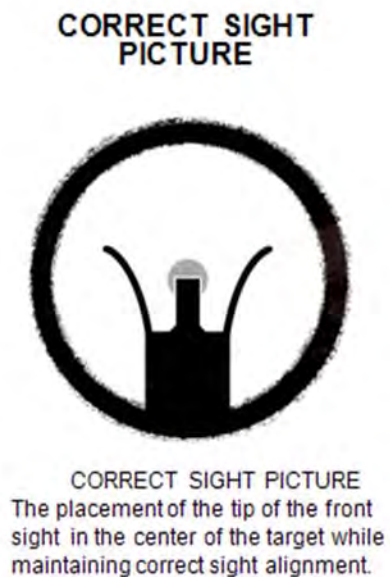
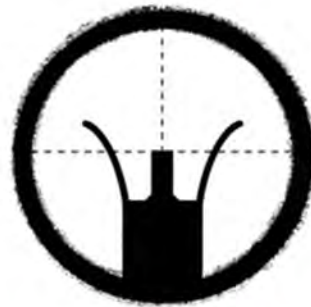

Figure 1. SIGHT PICTURE (From NAVMC 42, 2011)

## CORRECT SIGHT ALIGNMENT



CORRECT SIGHT ALIGNMENT  
The tip of the front sight post centered both vertically and horizontally in the rear sight aperture.

Figure 2. SIGHT ALIGNMENT (From NAVMC 42, 2011)

## 2. Breath Control

Along with aiming, breath control is another skill needed to assist the shooter in hitting the target. A shooter needs to be able to control breathing before, during and after the shot in the event that another shot is immediately required. The shooter must achieve the ability to interrupt their normal breathing during a shot. They must be able to know what is tolerable so as not to tighten up the grip of the weapon nor increase the heart rate causing the weapon to pulsate up and down in sequence with the heart.

## 3. Trigger Control

Trigger control is another fundamental taught. This must be in concert with breath control. Once the shooter has achieved proper aiming on a target, the shooter only has a few second, once the decision to interrupt breathing occurs, to pull the trigger. In this situation, the shooter must learn to effectively place the weapon from safe to fire and apply a consistent, smooth pull of the trigger to the rear engaging the bolt to fire a round. One the shot is fired the shooter must learn

to maintain a proper follow-through and recovery in order to prepare to fire another round directly after. This proper follow-through of the recoil of the weapon prevent the shooter from strenuously having to maintain proper sight alignment and sight picture (Fleet Marine Force Manual FMFM 0–9, 1995).

#### **4. Muscle Relaxation and Natural Point of Aim**

Other variables are considered when engaging a target such as firing position at the different distances of the Known Distance Course. This is where skeletal support and ensuring muscle relaxation are achieved. Achieving muscle relaxation is allowing a shooter to set into the aiming position using minimal muscular effort and allowing the skeletal frame of the body take on the brunt of weapon's weight while aiming. A shooter should not have to muscle their way to acquire a target. A shooter should achieve a position that gives the natural point of aim. Natural point of aim is achieved when the shooter brings the weapon up to the firing position without attempting to aim at the target and only looking through the aiming sights. The location where the weapon is pointing is considered the natural point of aim. The shooter must adjust their body so that the weapon is naturally pointed within the vicinity of the intended target. This allows the shooter to engage the target with less effort and enable the shooter to properly more accurately hit the target (FMFM 0–9, 1995).

### **C. CURRENT COMBAT MARKSMANSHIP TRAINING PROCEDURES**

The current training package practiced throughout the Marine Corps has always been geared around aiming with iron sights. The Marine Corps has now chosen to enhance the way shooters train with new technology that is now a part of the T/O arsenal of weapons. The Combat Marksmanship Training package is now implementing the use of the Rifle Combat Optics (RCO) for annual rifle qualification. This change in the course of instructions leaves range coaches to attempt their own derivation of instruction using the RCO. At the Combat Marksmanship Symposium ROP (2011), which occurs annually to identify

benefits and changes to marksmanship training in the Marine Corps, studies on the implementation of the RCO have been ordered to be conducted at The Basic School (TBS) in Quantico, Virginia; MCRD Parris Island, South Carolina; and MCRD San Diego at Camp Pendleton, California, with results still pending. These studies attempt to establish criteria that give a hint of significant improvement over the iron sights and an initial stab at the instructional techniques needed to teach with the RCO.

Iron sights have always been used as part of the training for entry-level marksmanship. Seasoned instructors have honed the art of shooting and refined the ability to teach the fundamentals. Knowing what to teach is one thing, but knowing what is being taught to the shooter, and also being equally applied by the shooters, is another. The one thing that seems to remain a mystery is a clear understanding of exactly how the student shooter is truly applying what they have learned. Periods of instruction are taught in a sequence that builds on top of each other—sort of like learning math, in order to know calculus there is a list of required prerequisites that need to be taught. Coaches can ask questions to the shooter but even that method is limited to the integrity of the shooter, especially when the shooter is in the fundamental stages of learning to handle a weapon. The same, interestingly enough, happens to shooters who have already been trained, especially if they have learned their own habits and may subtly refuse coaching.

Consistent acquisition of the target is pretty much how performance is measured, but what about shooters who have a consistent difficult time acquiring the target? If practice makes perfect, then how does a marksmanship instructor ensure their student shooters are practicing correctly, given all the fundamentals are aptly exhibited, or so it seems to the instructor? Fortunately, shooters at the entry level have not had the opportunity to acquire bad habits, given the shooter is coachable and has hopefully not inherited any bad habits prior to military training. This fresh foundation gives coaches the unique opportunity to establish a strong set of fundamental skills that can be built upon over the years of training

while active in the military. It is not until the shooter has achieved some personal self actualization in marksmanship that performance can be achieved at higher levels of expertise, but the good fundamentals need to be established from the start. This starts with identifying what variables are most influential to marksmanship.

#### **D. RELATED RESEARCH**

The research used to guide this study is geared towards marksmanship training using virtual simulations and the use of video capture to profile performance levels of shooters. These areas served as a stepping stone to determining the scope of study.

The Marine Corps is adjusting to include the Remote Combat Optics (RCO) component as part of the annual rifle qualification sustainment requirement. The reasoning behind this change was acknowledgement that Marines go into combat with these RCO as part of the required gear. So the question that derived from the Combat Marksmanship Symposium ROP (2011) was why not train and qualify Marines with what they actually use out in combat? The introduction of the RCO for marksmanship training adds another variable to the list of items to look for during the course. As RCO's are being introduced as part of the required training, how will coaches understand what the shooters are truly aiming in on? It is hard enough to trust, blindly, that the shooter is conducting proper sight alignment, sight picture and eye relief, and remaining consistent in those aspects to boot. The first phase in learning, according to Paul M. Fitts and Michael I. Posner (1967), in their series on "Human Performance," one of three phases of skilled learning is the cognitive phase. Fitts and Posner mention that, during this phase, skill learning requires understanding what needs to be accomplished and learning how to accomplish that task or acquire that skill being taught (1967). "A good instructor will call his attention to important perceptual cues and response characteristics and give diagnosis knowledge of results" (Fitts & Posner, 1967). Trained marksmanship instructors take their



knowledge of personal shooting and attempt to apply it their shooters. These known techniques in acquiring the target are used as a baseline profile in training shooters. Also, the number of days to training for sustainment marksmanship has shortened. Rifle Range training began with two days of instructional and demonstration classes to include a session of adjusting their weapon with a Battle-sight Zero, (BZO, more in detail about BZO to follow), then the shooters only receive two more days of live fire training on the range before qualifying. This is a change to receiving three days firing prior to qualification day. This in turn gives coaches less time to assess the shooter and get them qualified. The need maximizing their instruction to help trouble shooters pass and seasoned shooters achieve higher performance is even more prevalent.

### **1. Simulation Training**

A source reviewed for this thesis was one conducted by former Naval Postgraduate School Student, LtCol William Walter Yates, in 2001. His study titled, “A Training Transfer Study Of The Indoor Simulated Marksmanship Trainer” (ISMT), focuses on assessing the ISMT, referenced in Figure 3, as a whole or part-task “black box” trainer. The idea was to establish validity of ISMT’s ability to be a stand-alone trainer to aid in improving marksmanship fundamentals for the Marines Corps’ Known Distance Course annual qualification. Yates’ study focused on a transfer of training from a simulation to the real world. The intent was to establish effectiveness of the ISMT in training shooters in the basic marksmanship fundamentals and to also establish any possible indications that may hint that ISMT can be an effective predictor of live fire performance (2001).



Figure 3. ISMT (From Marine Corps website, 2011)

In Yates' study, the novice shooter was the population of interest. This aimed to determine if ISMT was just as effective as conventional method of instruction if given the same amount of time to train. Also, the metric used to determine training transfer was the use of the scoring method and comparing the final scores of both the simulated and live fire results after qualification on both.

Participants of the Marine Corps Recruit Depot training command from San Diego, California, were used for this experiment. The intent was to use shooters who were not currently training or have had minimal professional training. The second part of the experiment was to determine if ISMT provided improvement of skill by way of a "black box" trainer. The population for this study consisted of active duty personnel and students at the Naval Postgraduate School and civilians of the school. They were assessed by the consistent size of the mean diameter of the shot groups.

The first experiment failed to reject the null in that there would not be statistical significance in performance using the ISMT. This was due partly to the data collected and that possible improvements during the live fire training preceding qualification day may have had an effect on the performance score

achieve on qualification day. The second experiment failed to retain the null stating that there would be no difference in the performance improvement achieved by the shooter. The results showed a mixed number of data with some shooters having shown improvement and others not. Yates (2001) attributing the lack of significance between treatments and control to extreme changes in weather inherited by a gap of three weeks between the groups during live fire qualification—a confounding variable that was addressed by the author (2001) .

ISMT is a computer based system with screen projections and volume adjustable realistic audio, referenced in Figure 3. ISMT's are designed to provide marksmanship training for all weapons inherent to an infantry battalion from the M-9 pistol through the 81-mm mortar. The weapons use non-visible eye safe lasers, and shots are recorded for playback after action review. There are many different scenarios from zeroing, re-qualification, combat scenarios, shoot/don't shoot, as well as excellent programs for Call For Fire and Close Air Support training. To understand the capabilities of ISMT with respect to the Yates study, an excerpt of the study mentions the use of feedback provided to the shooter for training.

Simulated firing in the ISMT provides the shooter with:

- Almost immediate round to round feedback on performance.
- The feedback consists of several graphical displays task performance.
- The most basic feedback is the computed point of impact of the recruit's simulated round fired.
- Capable of accurately displaying the point of aim to a precision of two minutes of angle.
- At the distance of approximately 240 inches from the muzzle of the SRS (and the hit sensor camera) to the projection screen, the point of impact is accurate to a distance of approximately 0.14 inches [sin

$(2/60) * 240'' == 0.1396''$ ] on the projection screen which is slightly larger than one half of a 5.56mm bullet's diameter.

- The projected point of impact the ISMT can replay a real time trace of the shooter's point of aim prior to the instant the SRS is fired and also in the seconds after the weapon is fired during the recoil motion.
- The aim point trace along with the graphical representations of barrel cant angle, butt pressure, and trigger pressure are used to analyze the performance and correct technical deficiencies in the shooter's actions (2001).

In order to train shooters to be consistently accurate they need to be aware of certain human performance factors before, during and after the shot (Chung, K.W., Delacruz, G.C., dVries, L.F, Bewley, W.L., & Baker, E.L., 2006). An analysis of the shooters results are given and it will display the sensor data chart table, referenced in Figure 4. This chart displays the sensors results for each shot. This means that the shooter and instructor, if using a fully instrumented weapon that renders the sensor data possible, may see the red, yellow, green light criteria, but it would be difficult to know what the shooter was feeling at the third shot of a fifty-shot qualification course that takes approximately one hour to complete. Shooting is a complex cognitive skill that requires simplistic and immediate feedback to corrective training where needed (Chung et al., 2006).

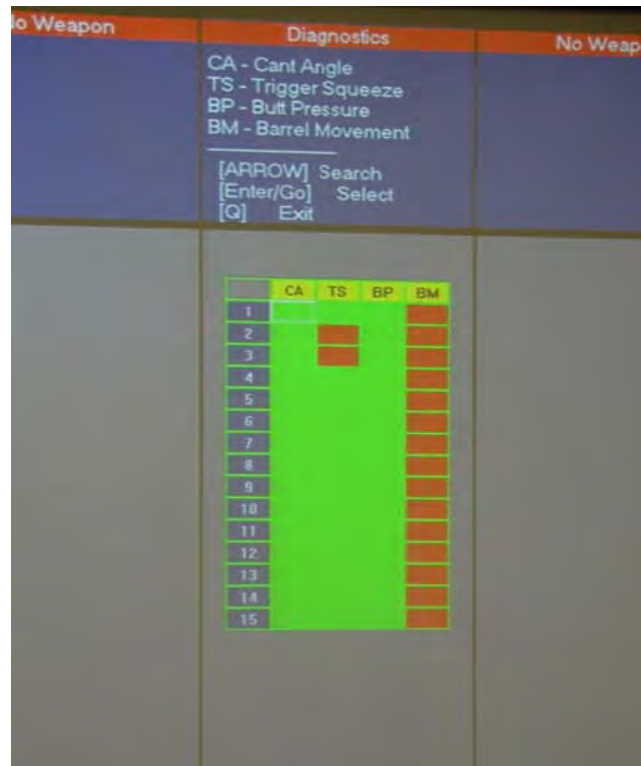

Figure 4. ISMT Sensor Chart (From Becker, 2010)

## 2. Motion Capture

In another thesis study titled, “Using Motion Capture To Determine Marksmanship Shooting Profiles: Teaching Soldiers To Shooter Better Faster,” conducted by Army Majors William L. Platte and Johnny J. Powers in 2008, the focus was on the use of the U.S. Army’s Engagement Skills Trainer (EST) and motion capture technology to measure profiles at various levels of marksmanship performance. EST is a simulation used by the Army for weapons familiarization, target acquisition and sustainment. It has screens that allow for human size projections and provides a multitude of marksmanship training. This simulator is much like the Marine’s ISMT earlier discussed. Their study set out to discover if it is possible to determine individual profiles and whether or not these profiles can predict the level of performance. All shooter participants were measured and predicted using the EST. The study goes on to mention that the identification of

complex skills for each individual is needed in order to understand how to best train the shooter. An excerpt from the study explains why the EST was chosen for further research by these two authors:

Each EST 2000 system can train 800–1,000 troops a month. An instructor runs the software that controls the system, and the training. Troops who have been through the “shoot/don’t shoot” simulator report that facing the real thing was a lot easier, less bloody, less stressful and less dangerous as a result. Troops who practice other types of combat situations on EST 2000 also report excellent results in combat. The simulator not only provides better training, but does it at less cost, and is much safer. Much like the payoff with flight simulators. (2008)

The Platte and Powers (2008) pilot study dealt with ensuring that the EST and the motion capture technology was interoperable with each other. They set out to gather a profile in the prone (lying down) position that is the most basic in nature and most stable of all other shooting positions. They collected expert marksmanship data using the camera and sensors to establish an expert profile for inclusion to a virtual avatar using a system derived by personnel of the Virtual research Center at the University of Iowa, named Santos.

Platte and Powers (2008) wanted to know if using the motion capture technology for instruction can validate the characteristics identified as the marksmanship fundamentals and if all characteristics are required to perform at a level of an expert. The authors also wanted to know if, using motion capture technology, they can establish clearly defined profiles of different levels of shooters and show, through the use of the Santos software, what an expert profile looks like. The study concluded that there were distinct differences in shooting profiles using the motion capture technology (Platte & Powers, 2008).

The Platte’s and Power’s (2008) study found that not all fundamental characteristics of marksmanship are required to be an expert. They continue to mention that there does have to exist some degree of smaller combinations of

these characteristics needed to be an expert. Breath control, trigger pull and aiming point are concluded to always be necessary in developing the skills of an expert shooter.

## **E. OTHER SOURCES**

In other related sources used for this study, the author found it useful to reference works that presented thoughts and ideas about teaching, learning and process of refining necessary variables for simple instruction. Also, another underlying prototype that prompted this study is discussed.

### **1. Process of Refining Necessary Variables**

Researchers Richardson, M., Jones, G., Torrance, M., Baguley, T., at the University of Derby, Staffordshire University and Nottingham Trent University, all in the United Kingdom, titled, "Identifying the Task Variables That Predict Object Assembly Difficulty" (2006), the focus of the study was identifying variables that make assembly of objects (desks, chairs, etc.) difficult, enable simpler instructions to the novice. They wanted to know if identification of object characteristics, along with their relationship on task variables needed for self-assembly of those objects, help identify the difficulty of the cognitive workload needed to successfully assemble an object.

This study conducted by Richardson et al. (2006), suggest that there exists a correlation of variables that can be summarized into a common set of generalized instructions that enhance assembly of objects. The level of difficulty to assemble any given object can be predicted in order to simplify a set of instructions using the following task variables: component groups, selections, symmetrical planes, fastening points, fastening (total number of fastenings required), novel assemblies (number of unique assemblies in a step), and components (number of components added in an assembly step). The principle focus in this experiment is to enable a simpler way to create a set of instructions for self-assembly of objects. According to the study, there seems to be four task

variables that significantly help to predict level of difficulty in assembly of objects: Components, novel assemblies, symmetrical planes, and selections (Richardson et al., 2006). Identifying influential characteristics to effectively increase performance and decrease mental workload is crucial. In Fitts and Posner's (1967) series on "Human Performance," the second phase of skill learning is the associative phase, "in which responses that must be made are learned and become readily available" (1967). Fitts and Posner (1967) discuss "proper sequence of practice" and how training can be segregated into "components for the whole task" (1967). By clearly understand the critical fundamental techniques to learning a skill, how the skill is learned by individuals, and being able to build upon those skills, can be the key to improving performance.

## **2. Tutoring and Learning**

In an article by Michelene T. H. Chi, Stephanie A. Siler, and Heisawn Jeong, from the University of Pittsburg, titled, "Can Tutors Monitor Students' Understanding Accurately?" (2004), the authors investigated whether or not tutors, both novice and expert, could adapt to learning exactly what the tutee's were understanding or not, and, if the tutee's understanding was incorrect, was it due to incorrect beliefs? In order for the tutors to be adaptive "the tutors must monitor the students' understanding or incorrect understanding accurately" (Michelene et al., 2004). This form of understanding refers to what the students believe to be true in their mind, and whether or not they are correct, can the tutor recognize this and correct the students' understanding of knowledge if the students are deemed to have an incorrect belief of that knowledge (2004).

One of the studies focused on analyzed focused on comparing "Normative Versus Alternative Understanding" (2004). In the article, Chi, et al. (2004) described normative to be "correct conceptual knowledge," knowledge to be textually factual and true. The authors continue to note that in respect to tutoring, "correct knowledge can also be the tutor's expectations, which may deviate from the normative" (2004).



Chi et al. (2004) discuss that students build mental models made up of beliefs they have learned and it is these models that “often reflects their deep understanding.” In order for tutors to accurately adapt understand the what the student correctly understands, the authors describe the difference between contradictory and false beliefs. They define contradictory to be an incorrect belief “if a correct proposition that is either explicitly or implicitly stated in a text [that] contradicts it” (2004). False beliefs “are incorrect beliefs that are presumably not addressed by any text that the students have encountered” (2004). The authors mention that contradictory beliefs are easier to remove than false beliefs because they are explicitly refuted” (2004).

Chi et. al. (2004) also described two forms of monitoring: Assessment and Diagnosis. Assessment, as defined by the authors, is monitoring from the tutors point of view, whereas diagnosis is monitoring taking the students perspective (2004). The intent of this study was to determine if tutors can accurately model what the student understands correctly. Results showed that “both experienced tutors and novice tutors (who were experienced teachers) do try to find out what information about the domain their students know from the normative but not the alternative perspective” (2004).

### **3. Packaged Sensor Feedback**

In a Thrust Technical Review conducted in November of 2010 on “Marine Corps Small Arms & Marksmanship Training,” presented by Dr. William (Bill) Becker, Research Professor at the Modeling of Virtual Environments and Simulation (MOVES) Institute, Naval Postgraduate School, Monterey, California, a project funded by Office of Naval Research set out to derive a system to answer one question, “ Can a system be designed that will give coaches on the live fire range some of the diagnostic tools that currently can only be found in a simulator?” (2010).

This system was to exploit capabilities existent within current training systems used for marksmanship training. In this review, Dr. Becker (2010)

proposed a design that brought diagnosing capabilities from the simulator out to live fire training. Though currently still in its prototype and testing stages, this Packaged Sensor Feedback was designed to address particular objectives (2010).

- Improve marksmanship skills acquisition/sustainment by developing automated assistance capability for coaches and students.
- Demonstrate the utility of a generalized training system model that links performance monitoring to customized training interventions with predictable training transfer.

The Package Sensor Feedback design currently provides automated feedback on butt-stock pressure, trigger pressure (left, center, right), and weapons cant (angle at which the shooter has the weapon while aiming). Figures 5 and 6 show the prototype appended to an M16A2 service rifle.



Figure 5. Sensor Components (From Becker, 2010)



Figure 6. Sensor Components (From Becker, 2010)

These features are currently seen in the Indoor Simulated Marksmanship Trainer (ISMT) for the Marine Corps. These particular characteristics can only be accessed by a fully instrumented ISMT weapon capable of transmitting these particular sensors. Within the ISMT, feedback of these sensors are shown in real-time on a monitor but cannot be recorded for further analysis. No capability to save this data exist in the ISMT. Dr. Becker's (2010) Package Sensor Feedback takes this concept and provides real-time sensor data feedback while shooters are either in the ISMT training or on the range conducting live fire training. Range Coaches are able to assess shooters on a shot by shot basis using an interface providing a simplistic stop-light approach for each sensor recorded, referenced in Figure 7.



Figure 7. Sensor Feedback Interface (From Becker, 2010)

This system allows for a coach to view up to four shooters on a single monitor. After observing this system in operation during a simulated testing phase, it provides the ability to save the data recorded to use for later analysis and in hopes to establish profiles aimed at possibly predicting levels of performance by comparison for shooters' data to established profiles.

### III. METHODOLOGY FOR EXPERIMENT

Most studies in the field of marksmanship training have been aimed at improving the skilled performance of the shooter. This study wants to gear the concept of skill acquisition from the coach's perspective of training—methods of instruction that are most effective and providing simplistic guidance for shooter's to receive during real-time live fire. "For tutors to be adaptive in the skillful execution of any of the tutoring tactics, the tutors must monitor the students' misunderstanding or incorrect understanding accurately" (Chi et al., 2004).

The design of the experiment used in this study focused on aiding the range coached with remote live video feedback. This apparatus called, "Split Shot Scope Transmitter, referenced in Figure 8, derived from Tactical Electronics & Military Supply LLC founded in (1999), was appended to the shooter's RCO for the duration of the live firing training, referenced in Figure 9.

The intent was to use shooters that are in their sustainment stages, or in terms of phased skills learned, in the intermediate phase of marksmanship but have not mastered shooting as experts. At the intermediate phase, shooters have graduated from the initial tasks of learning a new skill to focusing on turning the cognitive skills learned into learning to apply it to the motor skills required to employ the weapon (Chung et al., 2006). The coaches, in this sense, remain the cognitive skill level instructor. They are the subject matter experts in their field and concentrate on ensuring shooters maintain the correct fundamental mental techniques and procedures required to employ the weapons.



Figure 8. Split Shot Scope Transmitter (From Tactical Electronics, 1999)



Figure 9. Split Shot Scope Mounted (From Tactical Electronics, 1999)

Now that the RCO is becoming a part of marksmanship training, especially for use during annual qualification in the Marine Corps, the fundamentals will still apply as they do for any weapon, but now coaches have another feature to train—adding to the long list of obstacles that a shooter must learn to overcome.

## **A. EXPERIMENT WITH REMOTE COMBAT OPTICS**

### **1. Purpose**

The purpose of conducting an experiment with the RCO is to assess possible benefits that may provide marksmanship coaches with a viable aid for training shooters during live fire exercises on the KD Course. As mentioned earlier, this study is to assess any viable utility of live video feedback through the use of a remote camera attached the RCO. The question of focus is to identify an attempt to identify if there exists an effective method for aiding marksmanship coaches using live video feedback and instantaneous sensor feedback during live fire training? The null hypothesis is that there is no significant difference in the advantage of using the Split Shot Scope Transmitter in aiding coaches to instruct shooters during live fire training. \*[This study will also assess the results of the shooters who were able to append the Split Shot Scope Transmitter during live fire. The null hypothesis for this part of the study is that there is no significant difference between those shooters who have received coaching via the Split Shot Scope Transmitter and the shooters who received coaching without the aided enhancement.]

### **2. Subjects**

The participants selected were volunteers drawn from current active duty Marines whose current job is devoted to training shooters in achieving marksmanship qualification scores in the Marine Corps. Also, the shooters assessed were Marines who are currently conducting sustainment marksmanship training for their annual qualification requirements. The age range

of the coaches assessed ranged from 18 years old to 41 years of age. This allowed the study to receive a wide range of responses from skilled coaches who have only been coaches who are recently considered novice range coaches to season coaches training from four (4) to over ten (10) years experience in marksmanship training. All Marines are required to be proficient in the employment of their issued weapons. In this study, the weapons of choice are the M16A4 and the M4 carbine service rifles. These rifles are currently the weapon of issue in the Marine Corps arsenal..

### **3. Procedures**

The range coaches were introduced to the Split Shot Scope Transmitter prior to employing it on the range. They were able to get a review of the capabilities of the gear and learn how to append the system to the RCO.

Due to limited supply of Split Shot Systems, only four coaches were chosen and tracked with shooters while the shooters were conducting live fire training. All other coaches were able to use the system on their respective shooters in order to get an understanding of how to employ the system and assess any utility it may provide to their ability to better understand and instruct the shooter. Prior to handling the system, coaches and participating shooters were asked to take a demographics questionnaire (see Appendix B and C) . At the completion of the study the same participants were asked to complete a postsurvey (see Appendix B and C).

Two coaches were assessed for the first three relays firing. Each coach picked a marksman level shooter (or one that achieved marksman from the last qualification they participated in) if they had one for each relay. Otherwise, they were to match up each shooter with the Slit Shot System with equal shooters of at the same qualified level for the other two relays. This entails a combined total of six shooters (three per coach, one in each relay) with the Split Shot System. Since each coach technically can instruct four shooters under their charge at a time, the other shooters who did not have the Split Shot System were the control



variable. This was to mitigate any confounds inherited with multiple coaches. The last three relays followed suit with the other two coaches. Two coaches were picked who were considered to be seasoned instructors in the field and two coaches who were considered novice coaches. The two seasoned coaches took the first three relays and the novice coaches took the last three relays.

The shooters with the Split Shot System had the camera appended for the entire evolution of the two training days. Since there only were two Split Shot Systems available each coach was required to remove and place the camera on each shooter's weapon between changes of relays firing. At the conclusion of the two training days, no shooter had the Split Shot System on qualification day—standard operating procedures prohibit any coaching or guidance during final qualification day.

Data collection consisted of obtaining final scores on the rifle range from the shooters with the camera appended and receiving instruction from the selected coaches in charge of them, scores from the rest of the shooters in the same respective groups each coach was in charge of, and the survey data collected from the all coaches involved in order to obtain their professional opinion on the utility of the Split Shot Scope Transmitter.

## **B. SPECIFICATION OF THE SPLIT SHOT SYSTEM**

The Split Shot System offers the following specifications, referenced in Figure 10 show the following.

- 4.0 Hours continuous operation from two 3V Lithium CR123 cells
- Lens focal length: 20mm - 25mm
- 0.0003 lux B/W CCD imager
- 600 lines of resolution (B/W)
- 0.2 lux Color CCD imager
- 550 lines of resolution (color)
- Weighs less than 0.5 pounds

- LOS Signal Transmission just under one half mile w/ integrated RF transmitter
- One monitoring option: Head Mounted Monitor, Handheld Monitor, Wrist Mounted
- Monitor, or Monocular Micro Viewer
- Full interoperability with all Tactical Electronics monitoring options for multi-operator viewing of transmitted video.



Figure 10. Split Shot Scope and Monitor (From Tactical Electronics, 1999)

## C. CURRENT SUSTAINMENT TRAINING PROCEDURES

### 1. Table 1 KD Course

Rifle sustainment qualification follows the Marine Corps Individual Training Standards (ITS) set to provide a “foundation upon which unit commanders... build training packages for individual Marines as part of unit training plans or

formal courses of instruction” (Marine Corps Order MCO 1650.84A, 2000). The initial training for marksmanship takes place by learning precision shooting by firing live rounds on static targets from various distances. Depending on the size of the weapon detail for any particular week, shooters are split into a morning and afternoon groups. This way one group of shooters provides target assistance for those shooting and vice-versa. Any group may have up to four shooters per target in the morning and four per target in the afternoon. The first shooter at each target on the firing line is called the first relay, therefore, there may be as many as four to five relays per group. First and foremost, shooters need to conduct a battle-sight zero (BZO) at the 300 yard line or 36 yard line. Since the trajectory of a round passes the line of sight at two points, these two distances are the most effective to ensuring a weapon hits the target with consistency (Fleet Marine Force Manual FMFM 0-9, 1995). One of the most important ingredients to qualification is ensuring the weapon’s aiming components (front/rear sights, wind and elevation knobs, scope or RCO) are zeroed. This ensures that the shooters will hit what they are aiming at—keeping all other conditions normal as possible provides a strong setting for a uniquely tailored weapon and shooter combination (Student Outline 0300-M16-1004, 2008). After the shooters verify their issued weapons have their established BZO or are zeroed in, this zero becomes each shooter’s unique baseline for any further adjustment during the courses of fire.

One thing to note about the BZO and Zeroing process are their distinct differences. A BZO is conducted when attempting to establish a baseline for use of the iron sights. As mentioned earlier, the BZO can be conducted either at 36 yards or 300 yards to the target. A Zeroing of the weapon is conducted when establishing the alignment of the RCO to the weapon. There are two stages to this process: Stage One is the Pre-Zero Sight Setting that is conducted at the 36 yard / 33 meter distance; Stage Two is conducted at the 100 meter distance line. This establishes the setting on the RCO for firing the KD Course (The Basic

School (TBS) Marksmanship Student Outline, 2011). Appendix A shows the course of fire for the Table 1 of the KD Course.

The following ITS, provided by MCO 3574.2K (2007), met at this stage are as follows.

- 0300.M16.1005 Engage targets from a prone position with a service rifle/carbine.
- 0300.M16.1006 Engage target from a sitting position with a service rifle/carbine.
- 0300.M16.1007 Engage targets from a kneeling position with a service rifle/carbine.
- 0300.M16.1008 Engage targets from a standing position with a service rifle/carbine.
- 0300.M16.1009 Engage targets at the sustained rate of fire with a service rifle/carbine.

## **2. 200 Yard Line**

The first two stages of fire in Table 1 are at the 200 yard firing line. Shooters conduct live fire practice firing round in the sitting, kneeling and standing (off-hand) positions. In the first stage, shooters fire five slow and controlled rounds in each position in a time limit of twenty minutes engaging a static Able (A)-target, referenced in Figure 11. Each shooter is to have three magazines each filled with five rounds—no shooter is to have a loaded weapon (no round in the chamber or a magazine inserted) while transitioning from positions.

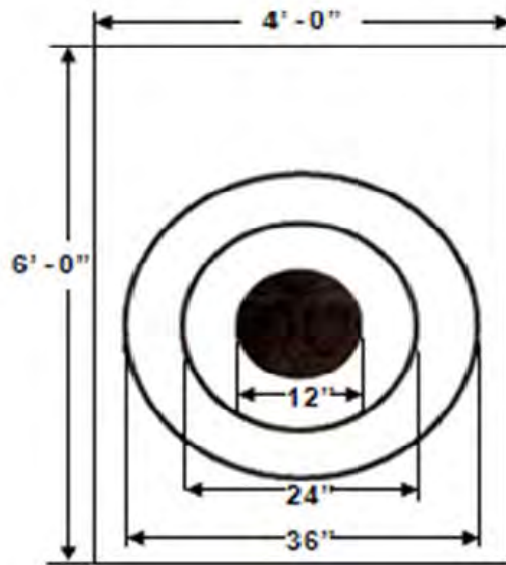

Figure 11. "A" TARGET (From NAVMC 42, 2011)

After every shooter in the first group completes this slow stage, the rapid firing stage comes next. In the second stage at the 200 yard line, rapid stage, shooters will engage a static Dog (D)-target firing ten rounds, referenced in Figure 12. Shooters will prepare for this stage by prepositioning themselves in the sitting position.

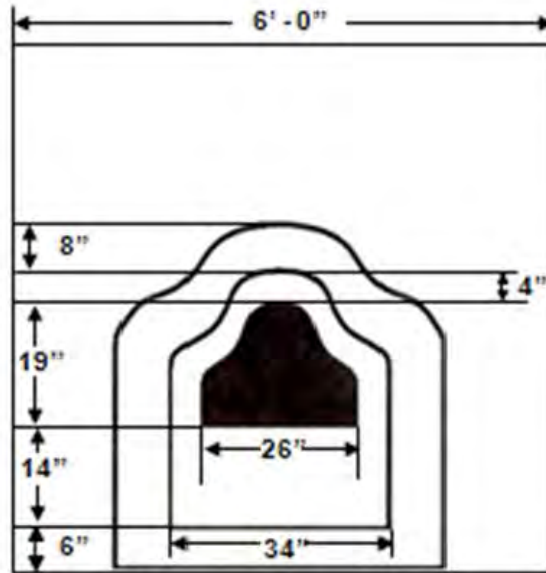

Figure 12. "D" TARGET (From NAVMC 42, 2011)

Next, they are to stand up, while trying to keep their feet in place in order to minimize adjustment of the natural point of aim. (Natural point of aim is acquired bringing the weapon up to the shoulder, relaxing all muscle tension and looking through the aiming components, front and rear sights without adjusting. The direction of the weapon while aiming is the natural point of aim. At this point the shooter will need to adjust the entire body to bring the weapon within the vicinity of the intended target allowing minor adjustments, afterwards, for precision aiming.) During the rapid stage the shooter will load the weapon chamber a round at this point. When given the command to fire, the shooters immediately take the seated position and begin firing in a time limit of sixty seconds. Shooters will fire a total of twenty-five rounds for a possible score of 125 points at the 200 yard firing line.

### 3. 300 Yard Line

The third stage of the Table 1 KD Course is conducted at the 300 yard firing line. This stage is slow fire stage where shooters will fire five round at a

static A-target, referenced in Figure 11, in the sitting position for a time limit of five minutes. The fourth stage is the rapid fire. Shooters will fire ten rounds at a static D-target, referenced in Figure 12, from the standing to prone (laying down) position in a time limit of sixty seconds. Shooters will fire a total of fifteen rounds for a possible score of 75 points at the 300 yard firing line for a range total of 200 points. At this point shooters will have had the opportunity to qualify at the marksmanship level for Table 1. It is possible that shooters will not have qualified at the minimal level by this stage (190 for minimum qualification).

#### 4. 500 Yard Line

The final stage of the Table 1 KD Course is conducted at the 500 yard firing line. Shooters take a prone position and obtain their adjusted natural point of aim. Shooters will fire ten rounds at a static B-mod target, referenced in Figure 13, while remaining in the prone position, for a time limit of ten minutes. The max possible total score at this stage is fifty points for a range total of 250 points. This is the most critical stage of firing due to not only climate conditions and distance, but also added stress of those shooters who are on the brink of not qualifying.

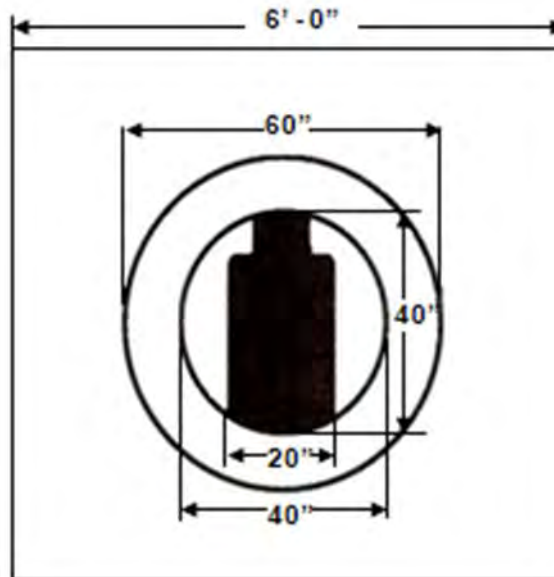

Figure 13. "B" TARGET (From NAVMC 42, 2011)

Though shooters obtain their Table 1 qualification score for marksman, sharpshooter or expert, they must still complete and pass the Table 2 course of fire to in order to pass their required marksmanship training. Table 1 qualification levels are as follows:

- a. Unqualified (0–189) pts.
- b. Qualified (190–250) pts.
  1. Marksman : 190–209
  2. Sharpshooter : 210–219
  3. Expert : 220–250

## **5. Table 2 KD Course**

After shooters qualify in Table 1 they are evaluated at the next table for engaging target of limited exposure, engaging targets during low light and darkness, engaging targets while wearing a field protective mask, engaging multiple targets, engaging moving targets, and engaging moving targets at unknown distances (Fleet Marine Force Manual FMFM 0–9, 1995). Shooters engage targets within distances of 200 yards depending on the capabilities of the range. This entire table is introduced the next day following qualification of the Table 1 course of fire. Shooters receive classroom instruction on Table 2 Basic Combat Rifle Marksmanship, (MCO 3574.2K, 2007) course of fire as well as training with live rounds on the same day. Shooters receive approximately 86 rounds for live fire training, plus an extra 34 rounds for BZO and Position Refinement prior to shooting the Table 2 course of fire, then return for a second day to qualify, this time only firing fifty rounds for a possible score of 100 points. Only Table 1 and Table 2 are currently scored for points towards the shooters annual qualification requirement. In order to qualify in Table 2 the shooter must obtain a minimum score of sixty (60) points. The following ITS, provided by MCO 2574.2K (2007), met at this stage are as follows.



- 0300.M16.1011 Demonstrate weapons carries with the service rifle/carbine.
- 0300.M16.1012 Execute a Tactical Reload with a service rifle/carbine.
- 0300.M16.1013 Execute a Speed Reload with a service rifle/carbine.
- 0300.M16.1014 Execute Controlled Pairs with a service rifle/carbine.
- 0300.M16.1015 Execute Failure to Stop Drills with a service rifle/carbine.
- 0300.M16.1016 Execute Multiple target Engagement with a service rifle/carbine.
- 0300.M16.1017 Engage a moving target with a service rifle/carbine.

Table 1 and Table 2 qualification scores for the three performance levels are as follows:

- a. Unqualified (0–249)
- b. Qualified (250–305) Table 1 & 2 combined
  1. Marksman : 250–279
  2. Sharpshooter : 280–304
  3. Expert : 305–350

## **6. Table 3 KD Course**

Table 3 is the Intermediate Combat Marksmanship period of instruction provided by the Combat Marksmanship Coach's (CMC) Course (Combat Marksmanship Course, 2006). This portion is not scored for qualification but Marine shooters must still demonstrate and pass the required skills taught at this level. According to the CMC Course (2006) and the MCO 3574.2K (2007), shooters must perform employment of the weapon by completing the following ITS requirements for marksmanship.

- 0300.M16.1019 Zero a Rifle Combat Optic to a service rifle/carbine.
- 0300.M16.1020 Zero a Target Pointer Illuminator/Aiming Light to a service rifle/carbine.
- 0300.M16.1021 Execute Hammer Pairs with a service rifle/carbine.
- 0300.M16.1022 Engage target using pivot techniques with a service rifle/carbine
- 0300.M16.1023 Engage targets while moving forward with a service rifle/carbine.
- 0300.M16.1024 Engage targets with a service rifle/carbine at night.
- 0300.M16.1025 Engage targets with a service rifle/carbine using a Target Pointer Illuminator/Aiming light.
- 0300.M16.1026 Engage targets from an unknown distance with a service rifle/carbine.

## **7. Table 4 KD Course**

The final table of the Marksmanship Course is Advanced Combat Marksmanship. This table reiterates Table 3. Shooters must pass a night course and engage targets while moving. In addition to conducting Table 3 again, they must also engage targets pivoting right/left and 180 degrees. The following ITS, provided by MCO 3574.2K (2007), met at this stage are as follows.

- 0300.M16.1028 Engage targets while using lateral movement techniques with a service rifle/carbine.
- 0300.M16.1029 Perform Advance Combat Marksmanship Skills (Table 4/Day) with a service rifle/carbine.
- 0300.M16.1030 Perform Advance Combat Marksmanship Skills (Table 4/Night) with a service rifle/carbine during night.

## **8. Remote Combat Optics (RCO) Instruction**

The change to use the RCO as a required item to be include in the Marine's Annual Sustainment Rifle Qualification has provided training battalions to derive some course of action to instruct shooters on its employment. As

mentioned earlier, the consideration to incorporate the RCO was partly in reply to it being a required item for use while being deployed to combat areas (CMS, 2011).

**a. RCO Fundamentals**

Just like the Iron Sights there is a technique required to maintain sight alignment. In the TBS Marksmanship Student Outline (2011), derived by the Weapons Training Company, Weapons and Training Battalion, at the Marine Corps Base Quantico, Virginia, the introduction of Sight Alignment is presented in terms of achieving correct sight picture by recognizing what is known as Scope Shadow as shown in Figure 14 , (2011). A shooter must get the appropriate eye relief (distance of the shooting eye to the eye piece of the RCO), which is approximately one to two inches, in order to eliminate large amounts of scope shadow. Otherwise the shooter must be diligent on achieving equal measure of scope shadow within the view of the RCO (TBS, 2011).

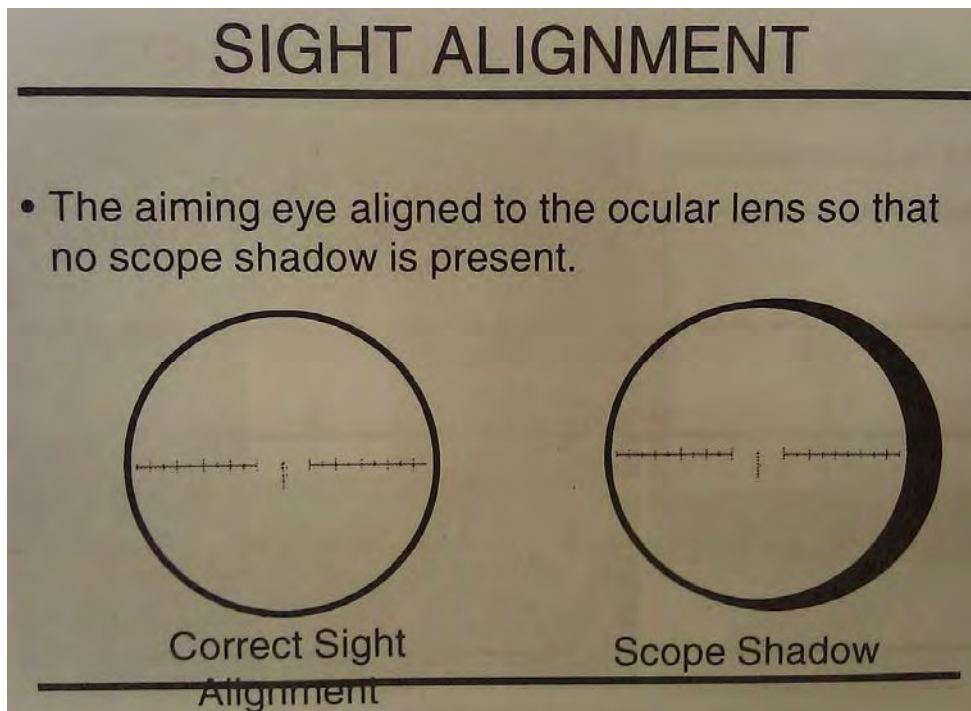

Figure 14. Scope Shadow (From TBS Marksmanship Student Outline, 2011)

Shooter must also learn how to use the appropriate scales marked within the RCO device itself, referenced in Figure 15. The distance of the target will determine what section of the reticle the shooter will use to engage (TBS, 2011). Proper Sight picture and reticle alignment are needed to properly engage the target with the RCO. This is one area that coaches are battling with on the range during live fire.

As mentioned earlier, shooters must Zero their RCO to their weapon. While the use of the Iron Sights are “zeroized” during the BZO stage at the 36 yard or 300 yard distance, the RCO zeroing is conducted at 100 yards as shown in Figure 16 (TBS, 2011). Figures 17, 18 and 19 show the reticle required to engage targets at the 200 yard, 300 yard and 500 yard firing line. One thing to note, once the RCO is zeroed, there are no further adjustments made to the RCO during the remainder of the of live fire shooting. Any adjustments are done by learning the use of the reticle and approximating the target.

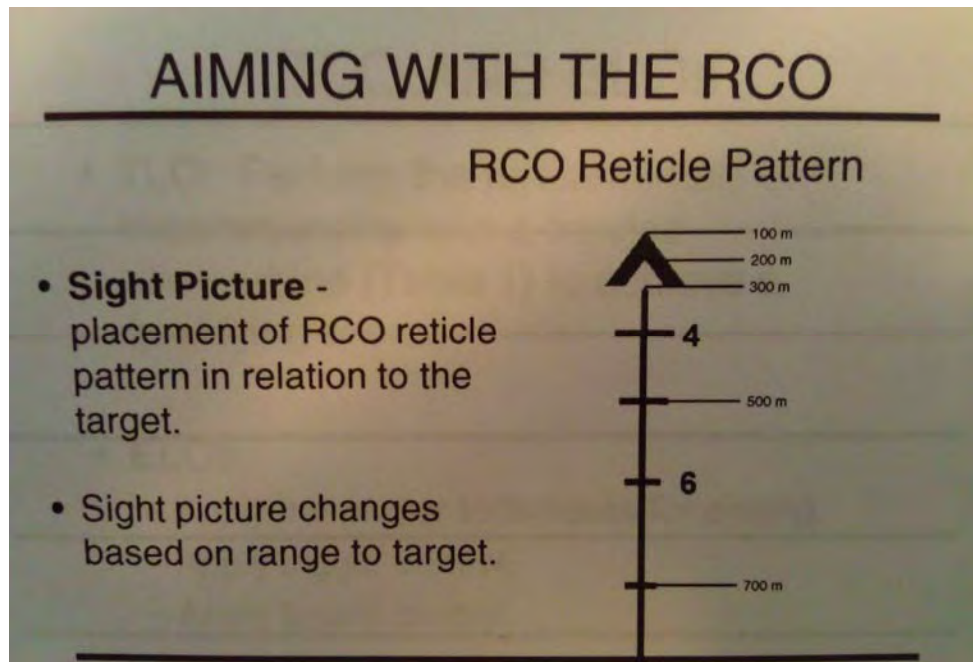

Figure 15. RCO Reticle Pattern (From TBS Marksmanship Student Outline, 2011)

## SIGHT PICTURE – RCO (100 YDS)

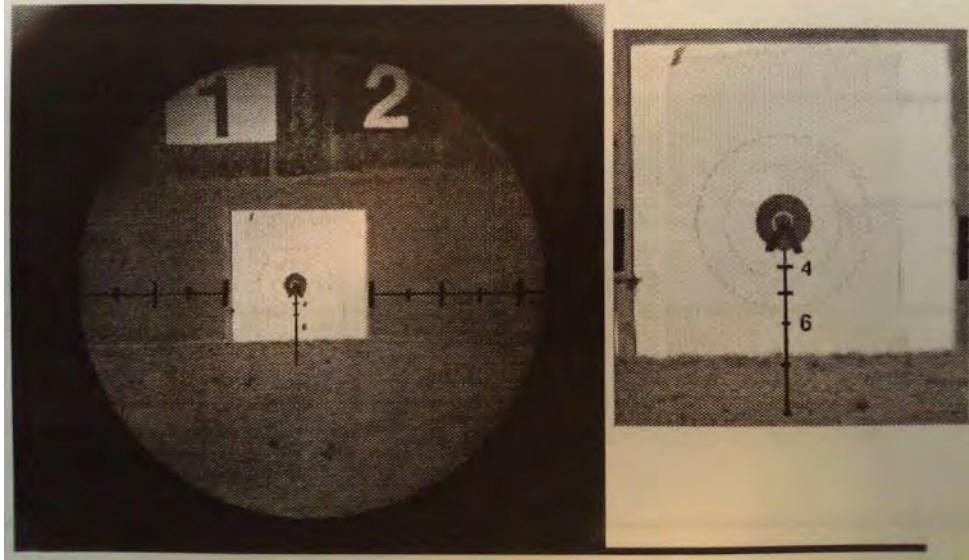

Figure 16. Aiming Sight Picture at 100 Yards (From TBS Marksmanship Student Outline, 2011)

## SIGHT PICTURE - RCO (200 YDS)

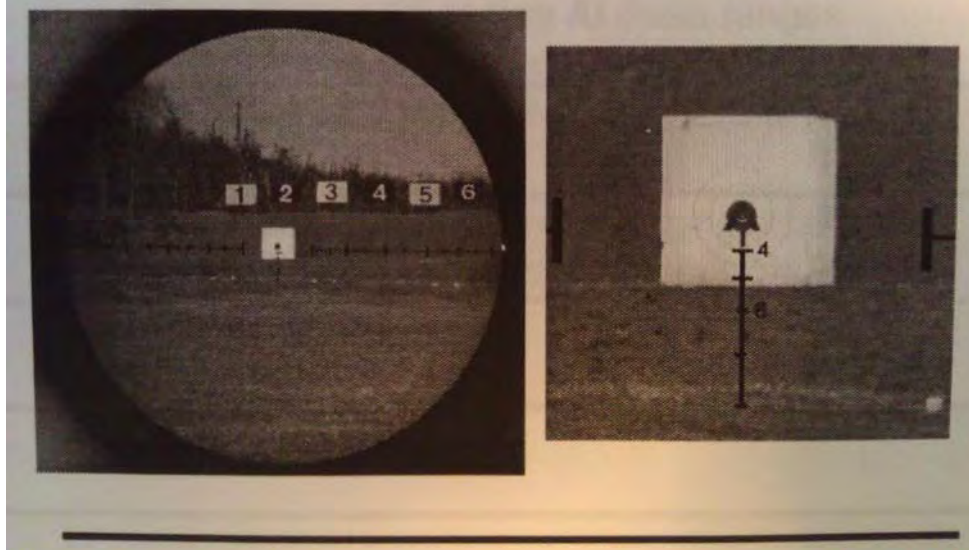

Figure 17. Reticle Sight Picture at 200 Yards (From TBS Marksmanship Student Outline, 2011)

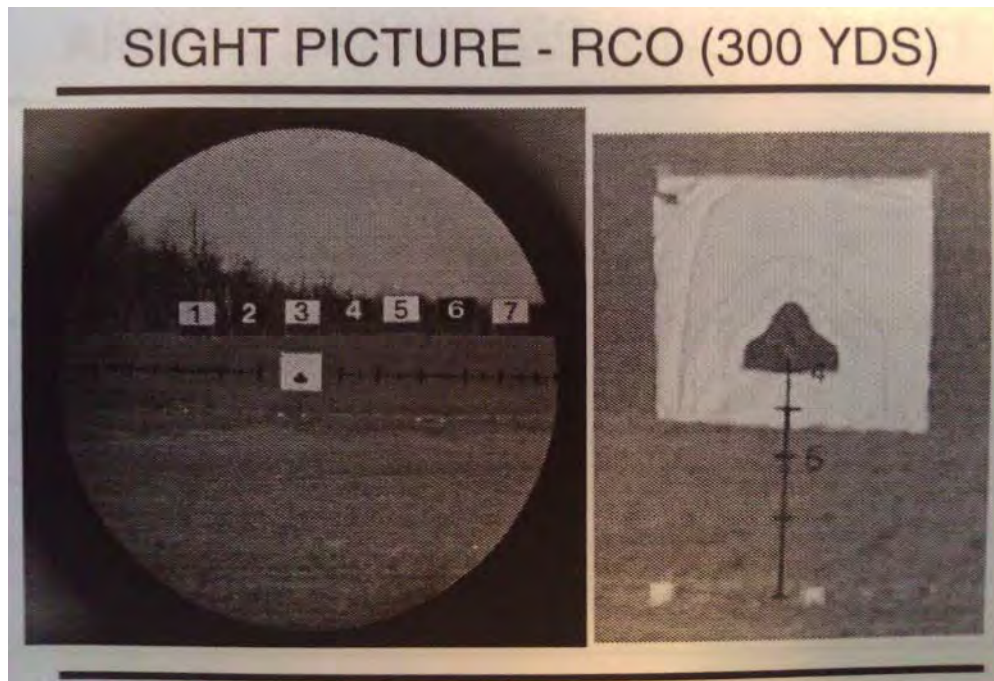

Figure 18. Reticle Sight Picture at 300 Yards (From TBS Marksmanship Student Outline, 2011)

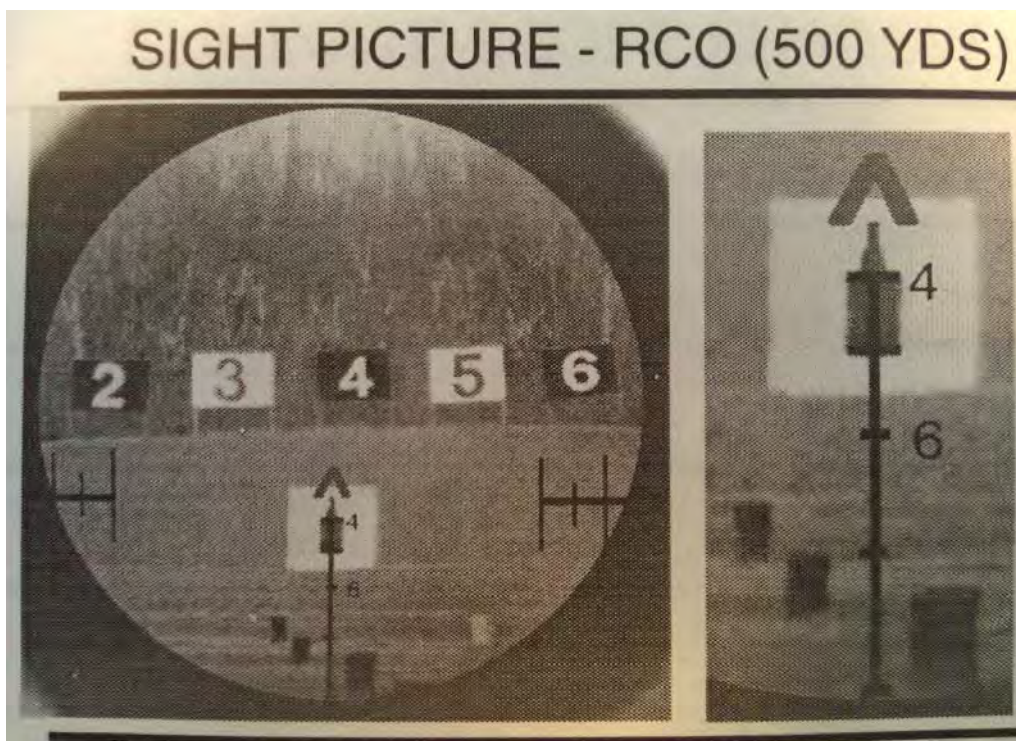

Figure 19. Reticle Sight Picture at 500 Yards (From TBS Marksmanship Student Outline, 2011)

“The RCO is designed to shoot with both eyes open” (TBS, 2011). The idea behind shooting at close distances (less than 100 yards) is to take advantage of the use of the chevron “through the dominant eye” as seen through the optics and while the “brain picks up the target and background via the non-dominant eye” thus merging the two together (TBS, 2011).

THIS PAGE INTENTIONALLY LEFT BLANK



## IV. RESULTS

### A. SUMMARY OF FINDING FOR THE SLIT SHOT SCOPE TRANSMITTER

The question of interest here is an attempt to find out if there exists an effective method for aiding marksmanship coaches using live video feedback and instantaneous sensor feedback during live fire training? After allowing the range coaches to use the Split Shot Scope Transmitter for training their selected shooters, other range coaches were allowed to append the system to a few of their shooters within their sections under their charge for the rifle detail.

After the conclusion of the firing week, coaches were asked to complete a postsurvey on their assessment of the use of the Split Shot Scope Transmitter as an aid for coaching shooters.

Figure 20 shows the responses to whether they felt it easier coaching the shooter with the Split Shot Scope Transmitter. Of the 18 coaches questioned in the study, 12 found that it is easier to coach with the system. Only three coaches found it difficult. The remaining three coaches mentioned either it was no different coaching either shooter, or they did not get the chance to thoroughly compare.

Of the coaches who found it easier, the common response was that they were able to actually see what the shooter was seeing while they were preparing to shoot and the follow through after the shot, something they have not ever been able to do during live fire. Coaches that did not find it easier to instruct the shooter with the system mentioned they had difficulty viewing the monitor because of the black and white contrast. Figure 21 shows the number of responses of the coaches who were considered to be seasoned (experienced) coaches.

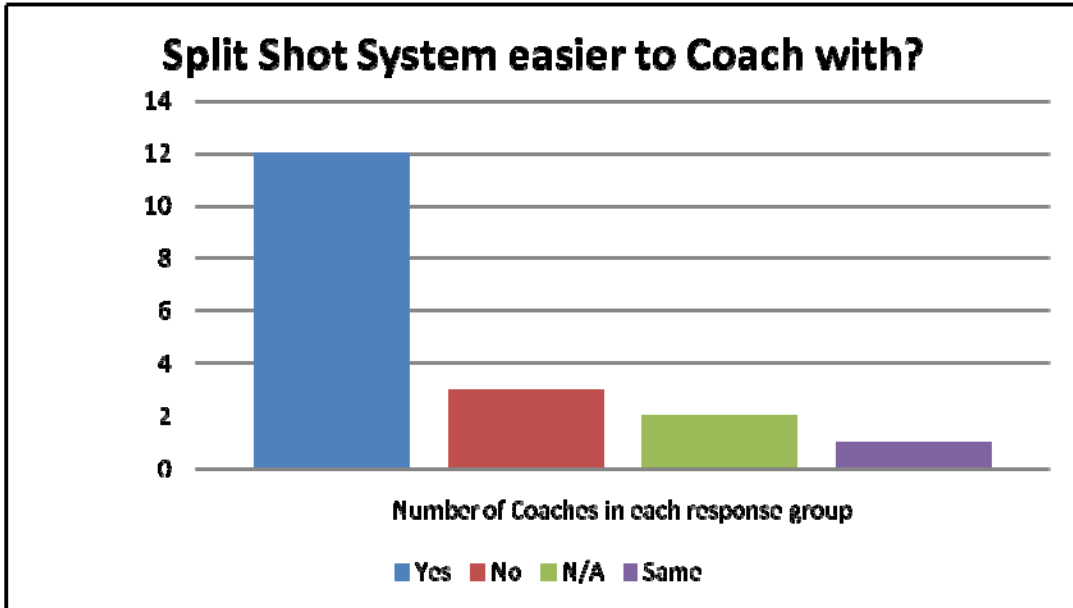

Figure 20. Post Question 6 (In comparison, did you find it easier to coach the shooter using the live video feedback than shooters not using the video feedback?)

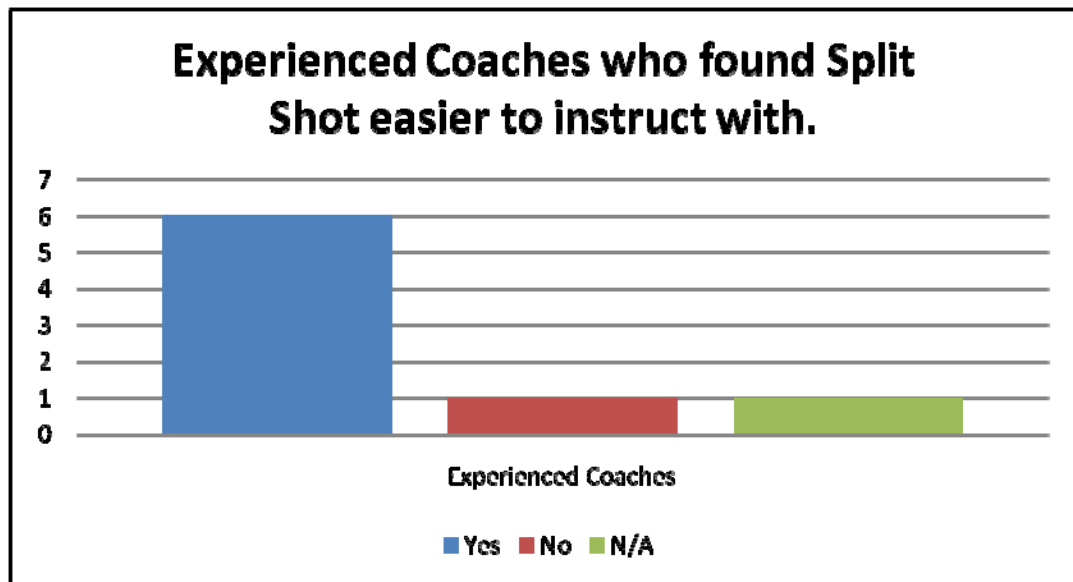

Figure 21. Experienced Coaches response to whether or not they found it easier to instruct using the Split Shot Scope Transmitter

Figure 22 shows the response to whether the coaches found themselves spending more, less or equal amount of time with the shooter who had the Split Shot Scope Transmitter in relation to the other shooter who did not have the system.

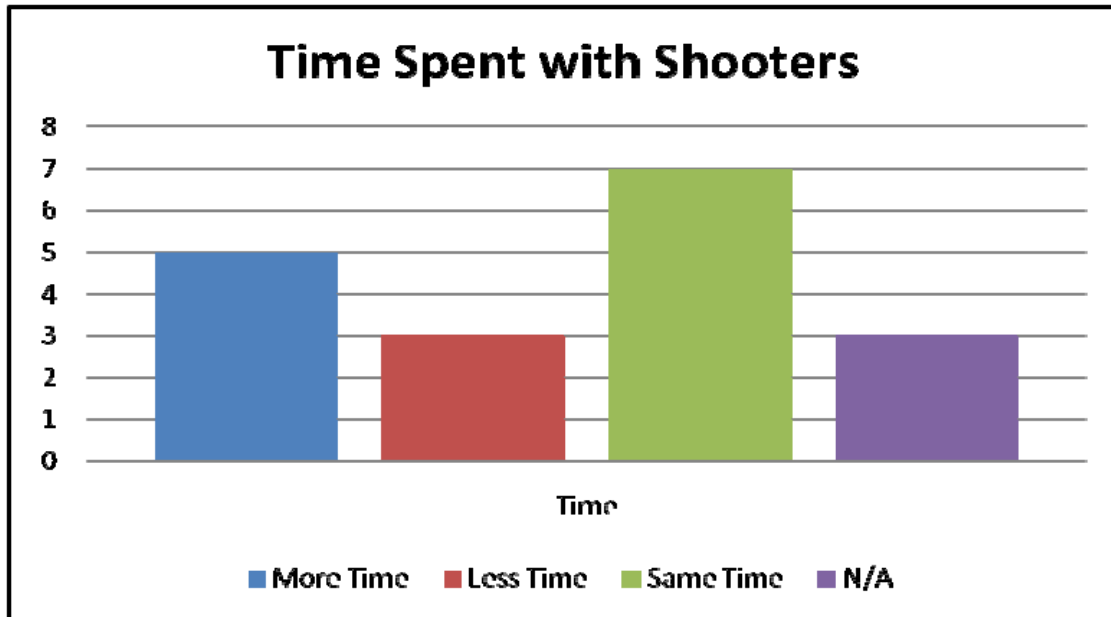

Figure 22. Post Question 7 (How much time did you find yourself spending on the shooter with the live video feedback than the other shooters not using the video feedback?)

Figure 23 shows the response of the experienced coaches of whether they felt they spent, or feel they would spend, more, less or equal amounts of time coaching the shooter with the Split Shot Scope Transmitter over the other shooter. One coach did mention that the reason he feels more time is spent on the shooter with the system is due to some much information now being presented to the coach, but that in turn, once they become accustomed to the system, they will end up spending less time diagnosing the shooter, something that coaches can normally spend days trying to figure out.

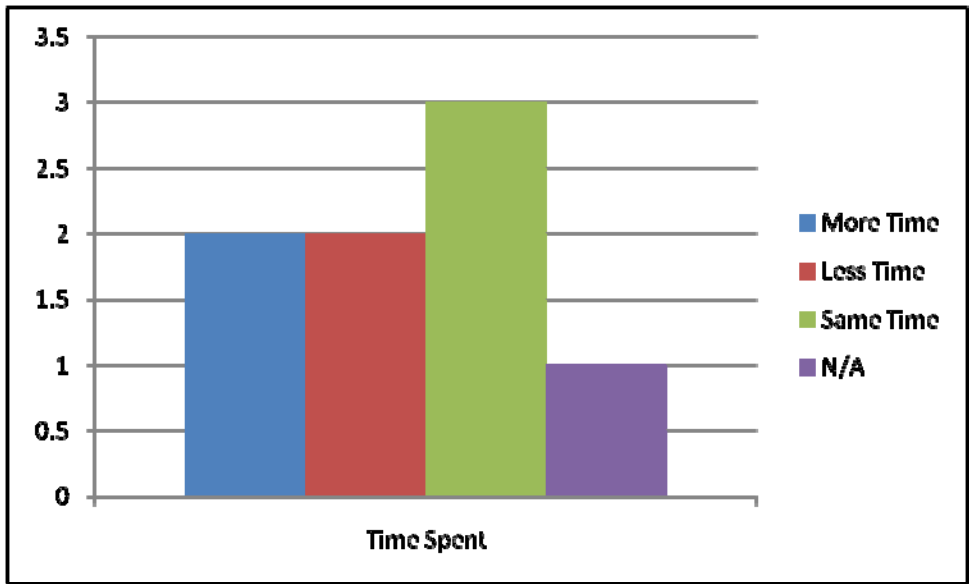

Figure 23. Experienced coaches response to whether they found themselves spending more, less or equal time with the Split Shot Scope Transmitter coaching shooters

Figure 24 shows the response to whether they felt the Split Shot Scope Transmitter live video feedback capability was useful in aiding their ability to diagnose and instruct the shooter. Some of the most common responses of this question is how they found it useful in their ability to visually see fundamentals such as breathing and aiming points that they would normally not notice. Other responses came in the form of how the Split Shot Scope Transmitter would take too much time to be used as an aid. The other comment was their preference to coach better by normal procedures (the naked eye). Another interesting comment was mentioned as to how the Split Shot eliminated the guessing for one coach.

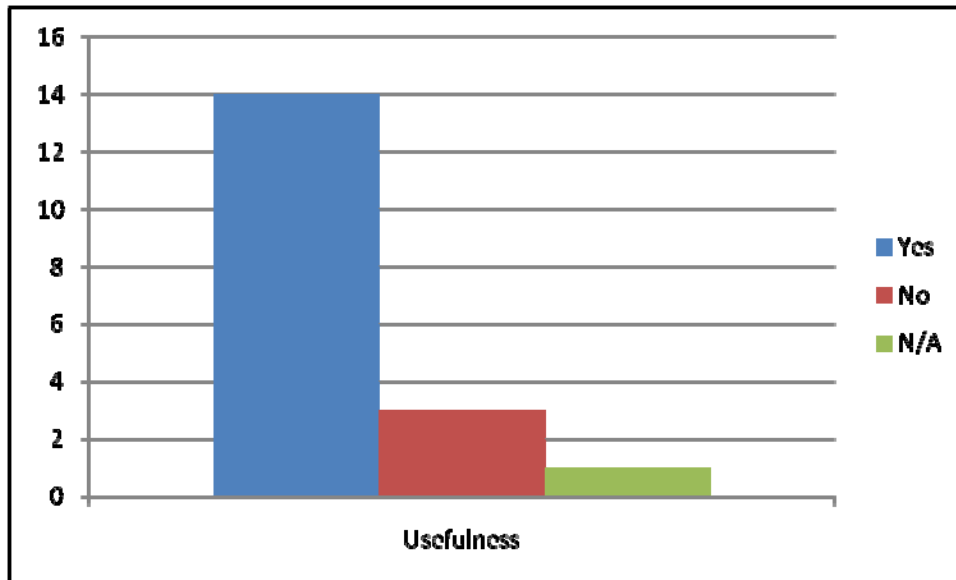

Figure 24. Post Question 8 (Do you feel the optical video feedback device was useful in aiding your coaching with the RCO?)

Figure 25 shows the response of the experienced coaches, only, in relation to their assessment of the usefulness of the Split Shot Scope Transmitter to instruct the shooter.

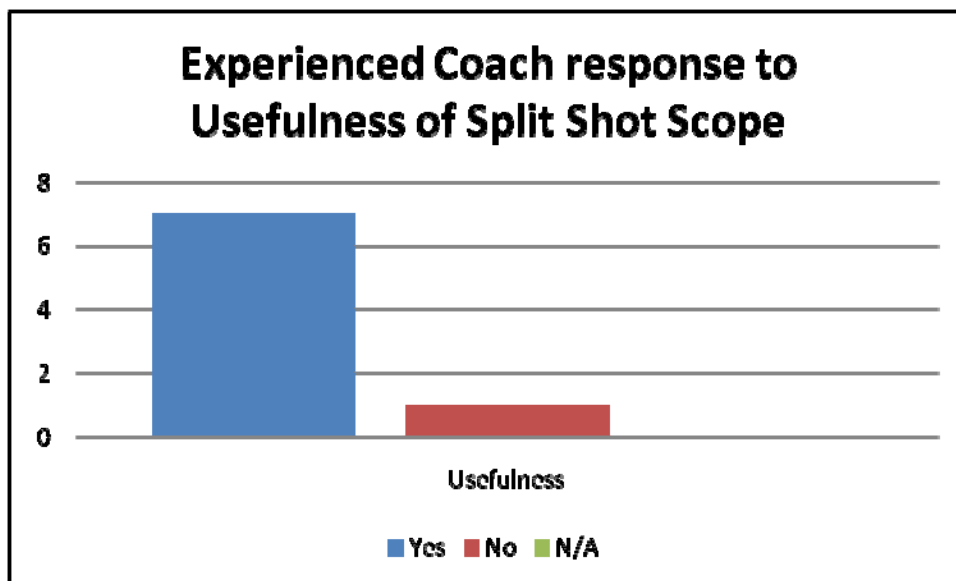

Figure 25. Experienced Coaches response to Usefulness of System

Figure 26 shows the response of the coaches assessing whether they felt the Split Shot may have eliminated some unknown factor in their diagnosis of the shooter that they would not have otherwise realized. The majority of the responses mentioned how they were able to notice the follow through of each shot as it is seeing through the scope—a completely different perspective. Also, coaches were able to ensure that the shooter was aiming and using the proper aiming, rather than taking the shooter at their word and trusting blindly they were conducting the correct techniques.

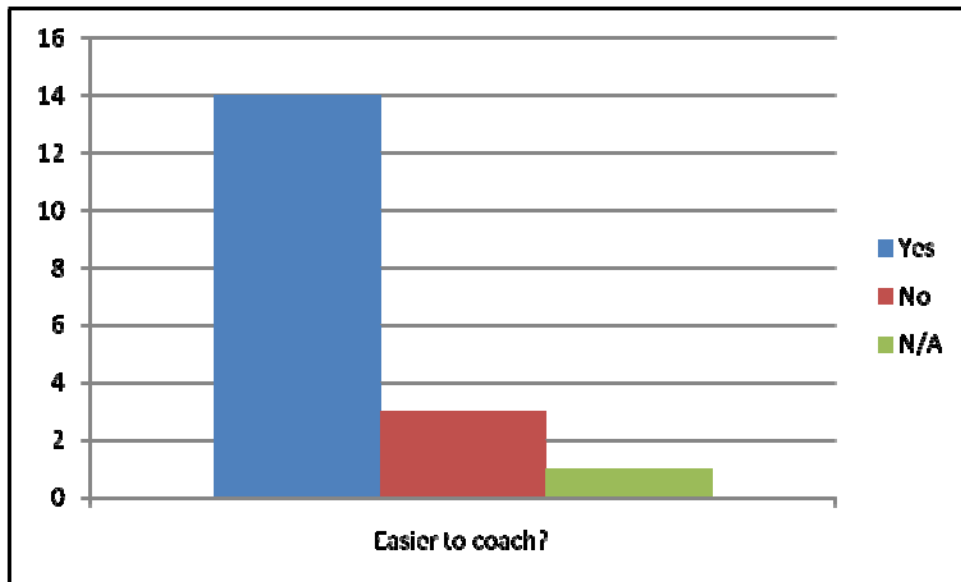

Figure 26. Post Question 9 (Do you feel that using video feedback on the RCO eliminated some unknown factors and made it easier to focus your coaching of the shooter in other areas?)

Figure 27 shows the responses to the ability of the Split Shot Scope Transmitter to eliminate unknown factors.

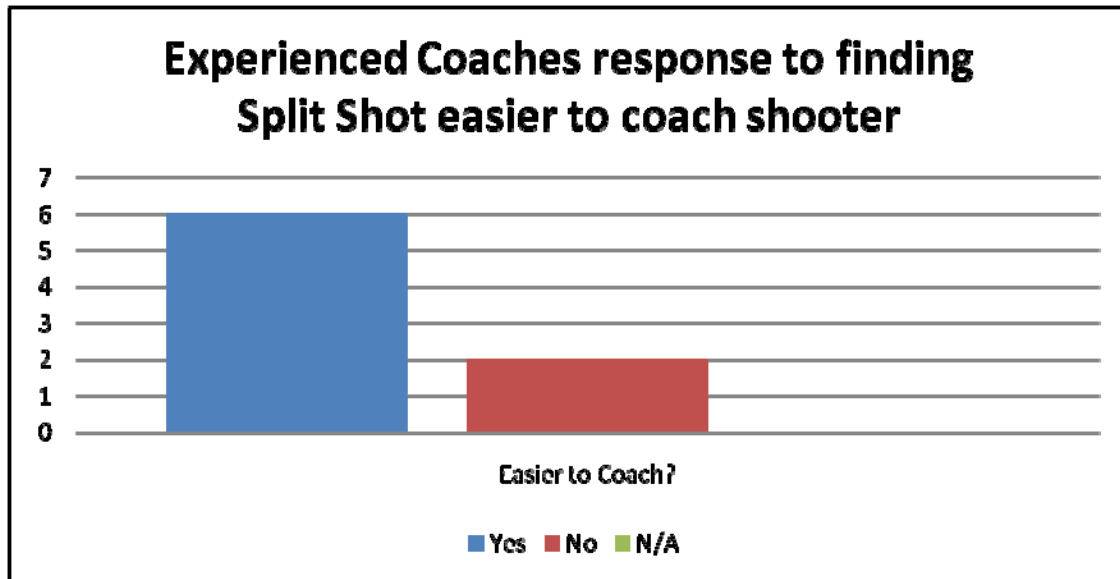

Figure 27. Experienced Coaches response to whether they found it easier to coach shooter given the system eliminated some unknown factors

When asked in the postsurvey whether or not the coaches felt that this had improved the shooters performance on the range, the majority had mentioned it had not. There may not have been enough time to notice this aspect, though, they were able to correct a few shooters that did clarify some confusion while they were shooting. In the added comment section of the postsurvey, a longtime expert shooter, in his more than 23 years of active duty service, and sniper for the Marine Corps, Infantry Weapons Officer for Marksmanship Training Company, Weapons Training Battalion mentions, “This is the piece that we have been missing. I see opportunities to place this device on other weapons with other optical sighting systems (i.e., machine guns with optics, M27 IAR, rockets, missiles, etc)... in theory, this device enhances training efficiency” (Gunner Christian P. Wade, CWO3, United States Marine Corps, 2011).

The shooters with the Split Shot Scope Transmitter appended to their RCO for the duration of the two live fire training days were asked to fill out a

demographics questionnaire and a post question after the completion of Table 1 of the KD Course. The initial attempt was to collect data scores from 12 shooters who were being coached by the range coach and the Split Shot System combined. Unfortunately the last four relays were omitted due to a few shooters requesting to opt out of the study because they felt the Split Shot component was hindering their ability to clearly see and aim in on the target, having a shooter not show up on the final day of qualification. Since there were only five complete relays and the sixth only being half a crew, there didn't exist enough data to statistically determine any meaningful evidence in the performance of the shooters using the Split Shot Scope Transmitter in comparison to the control group of shooters.

To note, the shooters that did have the appended Split Shot System on the first day, whether or not they completed the study or firing on qualification day, three improved one level from their previous skill level, one improved from a marksman to an expert shooter, one shooter remained at the same skill level as the previous, one was disqualified for not showing up on qualification day, one actually failed to qualify but was later allowed to fire again with the afternoon relays to obtain the default minimum score of 190 to pass the Table 1 phase of the KD Course.

After the assessments were completed, the use of the Split Shot Scope Transmitter shows potential to be a positive compliment to aiding marksmanship coaches in diagnosing and training shooters during live fire. This study still fails to reject the null hypothesis that there is no significant difference in the advantage of using the Split Shot Scope Transmitter in aiding coaches to instruct shooters during live fire training. Due to limited equipment and only two relays left for comparison, there was not sufficient data to collect showing any statistical effect influencing the shooters.



## **V. CONCLUSION AND RECOMMENDATION**

In conclusion, this study provides a discussion on some obstacles and technical difficulties and recommendations for the use of the Split Shot Scope Transmitter.

### **A. OBSTACLES AND TECHNICAL DIFFICULTIES**

Participation during the study was limited due to the inability to obtain all coaches of the command. This was partly due to a current Combat Marksmanship Coaches Course that ran concurrently with this study. Regardless of this issue, there are still a limited amount of coaches allotted to each rifle range and are mostly dependent on other demands for the training battalion. Multiple sessions should be conducted in order to obtain a broader response to this study.

Data collected from the shooters for comparison was limited. Shooters were pulled off the rifle range, or did not fire during the final qualification day, for a number of reasons that are uncontrollable in the study. As a results, this study had to drop a between groups study and only show the outcome of shooters who did use the camera while receiving coaching concurrently.

Technical problems were limited. One issue that arose was how often the C123 3Volt batteries had to be swapped out. Also, the coaches recognized the amount of the heat felt on the monitoring device. According to the technical specifications of the system, the Split Shot Transmitter can work up four hours continuously. The study found that, at most, the life of the batteries in the transmitter lasted on an average of three hours without turning it off. The monitor of the Split Shot System lasted on average between 30 minutes to one hour—1.5 hours at best. In order to extend the life of the batteries, the coaches were instructed to turn off the monitor while instructing the other shooters not with the system appended then turn it on again as needed. This extended the monitor's

batteries on average of 45 extra minutes. Since the Split Shot Scope was on the weapon while shooting, it was not turned off except only when transitioning from the different firing lines. The monitor operated either on an AC adaptor or on four C123 3Volt batteries while the Split Shot Scope Transmitter operated only on two C123 3Volt batteries.

Another complaint of the Split Shot Scope itself was the location of the placement on the RCO. Once appended the closest facing edge of the Split Shot Scope to the shooter shortened their ability to obtain proper eye relief to the RCO. This was mostly that the Split Shot Scope's closest edge was at the common distance that a shooter's eye relief was obtained. This may have been a good guide for those not knowing how to get the appropriate distance, but as a result, during the recoil of the weapon when fired, it would give a jab to the forehead of the shooter. Also, placement of this system seemed to only accommodate left handed shooters. Since it was a conflict for some shooters to fight with eye relief, a hasty adjustment to this issue to keep the shooters participating was to append the system to the other side as best possible. Though this adjustment was not aesthetically pleasing on the monitor, nor was it always easily placed on the opposite side, when it did lock into place it did allow the coach to view the center aiming points on the RCO while eliminating any hindrance to the shooter.

The monitor was easily operable and mobile but contrast was difficult to observe the picture during brighter days. Bright light overwhelms the power of the black and white contrast, especially outdoors where it will mostly be used. Problems of the monitor getting extremely hot was another issue observed from the study.

## **B. TRAINING OUTCOMES AND RECOMMENDATIONS**

The design of the study called for the Split Shot Scope Transmitter to be appended to the shooters RCO for the duration of the training days. This inadvertently resulted in learning how best employ and exploit the benefit of the system. A technique recognized for the use of the Split Shot Scope System was to only append the Scope Transmitter to a shooter the coaches have identified to need additional help. Since the system is easily employed (less than 30 seconds), coaches have the ability to diagnose in more detail what possible inconsistencies the shooter is showing. Viewing the actual target through the RCO from the shooters perspective allowed the coach to recognize the sensitivity in the aiming felt by the shooter. This live video feedback ability provided the coach an avenue to view breath control, proper sight alignment, and follow through after the shot, in turn being able to better diagnose the shooter in a shorter time.

Given that shooters have two training days of live fire prior to qualifying for their annual sustainment, coaches may use the first day to observe the shooters and determine which shooters need additional help. This Split Shot System can then be applied in a virtual marksmanship simulation and later applied on live fire training the next day. This will provide the coaches to diagnose the shooter's fundamentals not normally recognized otherwise. A reoccurring recommendation, from the participating coaches, resulting from this study was to only use the Split Shot System only after identifying a shooter needing help and to use this system in short spurts. In other words, this system should not be left on the shooters weapon for the entire evolution of live fire. It should only be used to help diagnose any problems the shooters might be exhibiting that the coach has not verified without the system. This recommendation was also partly due to complaints from the shooters who used the Split Shot eyepiece overlay, and at points of larger distances than 300 yards, the grey tint that exists on the camera area of the eyepiece hindered some ability to clearly view the target and scope shadow.

A recommendation for the modification of the Split Shot System would be to primarily modify how the monitor obtains its power. A small battery pack with longer life would suffice. Since this system is used in close distances, the requirement for the monitor to be light can have some fluctuation. Secondly, allow the ability to rotate the Split Shot Scope Transmitter from one side of the RCO to the other by use of a catch and release switch. Lastly, possible adjust the contrast of the picture on the monitor to allow it to be more easily viewed under bright natural light.

### **C. FUTURE WORK**

This study only scrapped the surface in attempting to address a gap in the current changes to marksmanship training. One study for future work would entail using the Split Shot Scope System for additional training within ISMT for a transfer study. ISMT has provided the ability for trouble shooters to receive additional instruction from range coaches but no methodology have proven consistently successful on the live firing range. Providing the ability to view the sensitive movement through the shooters point of view may provide some insight to a viable training method for effectively using ISMT as a predictor for live fire score.

Secondly, the sensor capabilities within ISMT provided excellent feedback for each shot while the shooter is firing in the simulator. The problem with this feature is the inability to capture this data for instantaneous shot by shot analysis for both the shooter and coach to view. Data cannot be automatically saved during this fully instrumented feature nor is it (has not been) proven to be a trusted feature to improving a shooters live firing results due to the shear fact that this sensor capability is only inside the ISMT.

A fully capable and mobile sensor package system, derived from similar concept, has provided the ability to assess a shooter on the live firing range. The mobile sensor package may be appended to any small arms weapon and provide instantaneous collectable data as the shots are fired. The sensor package

transmits wireless capabilities to a hand-held device for the coaches to monitor. This provides the coaches with immediate results in the form of a simplistic green, yellow, red light criteria for each sensor recorded (butt-stock pressure, trigger pull, weapons cant). The ability to record this data, in and out of the ISMT, can be studied to predict shooter performance without using the scoring feature within ISMT.

THIS PAGE INTENTIONALLY LEFT BLANK

## APPENDIX A. TABLE 1 KNOWN DISTANCE COURSE

Table 1 Course of Fire: Training Days												
<u>Distance</u>	<u>Target</u>	<u>Time</u>	<u># of Rounds</u>	<u>Position</u>								
<u>Tri-fire</u> 200 yds	"A"	60 sec per string	10 (3,3,4)	Sitting								
<u>Stage One</u> 200 yds 200 yds 200 yds 200 yds	"A"	25 min	<table style="display: inline-table; vertical-align: middle;"> <tr><td style="border: none;">}</td><td>5</td></tr> <tr><td style="border: none;">}</td><td>5</td></tr> <tr><td style="border: none;">}</td><td>5</td></tr> <tr><td style="border: none;">}</td><td>5</td></tr> </table>	}	5	}	5	}	5	}	5	Sitting Kneeling Standing (Sitting, Standing, or Kneeling)
}	5											
}	5											
}	5											
}	5											
<u>Stage Two</u> 200 yds	"D"- MOD	60 sec	10 x 2	Standing to Sitting								
<u>Stage Three</u> 300 yds	"A"	5 min	5	Sitting								
<u>Stage Four</u> 300 yds	"D"- MOD	60 sec	10 x 2	Standing to Prone								
<u>Stage Five</u> 500 yds	"E"	15 min	15	Prone								

Annual Rifle Training ART-A.14, (2008)

Table 1 Course of Fire: Qualification				
Distance	Target	Time	# of Rounds	Position
Stage One 200 yds 200 yds 200 yds	"A"	20 min	5 5 5	Sitting Kneeling Standing
Stage Two 200 yds	"D"-MOD	60 sec	10	Standing to Sitting
Stage Three 300 yds	"A"	5 min	5	Sitting
Stage Four 300 yds	"D"-MOD	60 sec	10	Standing to Prone
Stage Five 500 yds	"E"	10 min	10	Prone

Annual Rifle Training ART-A.14, (2008)



## APPENDIX B. DEMOGRAPHICS QUESTIONNAIRE/ POSTSURVEY (SHOOTERS)

### **Error! Not a valid link.**

14. Have you ever qualified with the Rifle Combat Optic (RCO) device? (circle one): Yes No
- a. If you answered yes, what was your level of the qualification with the RCO?
- i. Novice
  - ii. Marksman
  - iii. Sharpshooter
  - iv. Expert

### **Post Critique**

Directions: Write a short answer for the following questions. **Please print clearly.**

#### **Sensor:**

1. How useful do you think the Indoor Simulated Marksmanship Trainer, would be for marksmanship training?
  
  
  
  
  
  
  
  
  
  
2. Did you ever feel the sensors were a distraction while firing in both the simulator and live fire? If yes, what part / component was a distraction?
  
  
  
  
  
  
  
  
  
  
3. Do you think simulated training using the sensors enabled you to better correct your shooting technique? Explain.
  
  
  
  
  
  
  
  
  
  
4. Explain your experience with using **ANY** simulations for formal training? (ex. Ship handling, simulator, flight simulator, motorcycle simulator)
  
  
  
  
  
  
  
  
  
  
5. Have you ever played shooter games on any gaming system? If yes, on average how many hours a week?

#### **RCO:**

6. Did you find the optical camera a distraction while shooting? (circle one):    Yes            No  
    a. If yes, please comment below:

7. Any additional comments.

## APPENDIX C. DEMOGRAPHICS QUESTIONNAIRE/POSTSURVEY (SUBJECT MATTER EXPERTS)

**Error! Not a valid link.**

9. Have you ever used a Marksmanship simulator prior to this study? (circle one): Yes No
10. Have you ever qualified with the Rifle Combat Optic (RCO) device? (circle one): Yes  
No
- a. If you answered yes, what was your level of the qualification with the RCO?
- v. Novice
  - vi. Marksman
  - vii. Sharpshooter
  - viii. Expert

### **Post Critique**

Directions: Write a short answer for the following questions. **Please print clearly.**

#### **Sensor:**

7. How useful do you think the Indoor Simulated Marksmanship Trainer, would be for marksmanship training?
8. After viewing the sensor system in operation, what is your assessment while shooters fired in both the simulator and live fire?
9. After viewing the system in operation, do you think simulated training using the sensors would enable you to better assist in your instruction to shooting techniques? Explain.
10. Explain your experience with using **ANY** simulations for formal training? (ex. Ship handling, simulator, flight simulator, motorcycle simulator)

11. Have you ever played shooter games on any gaming system? If yes, on average how many hours a week?

**RCO:**

6. In comparison, did you find it easier to coach the shooter using the live video feedback than shooters not using the video feedback?

7. How much time did you find yourself spending on the shooter with the live video feedback than the other shooters not using the video feedback? (circle one)

- a. More time was spent on the shooter with video feedback.
- b. Less time was spent on the shooter with video feedback.
- c. The same amount of time was spent on all shooters regardless of the video feedback.

8. Do you feel the optical video feedback device was useful in aiding your coaching with the RCO? (circle one): Yes No

- a. Please provide your comments below.

9. Do you feel that using video feedback on the RCO eliminated some unknown factors and made it easier to focus your coaching of the shooter in other areas? (circle one): Yes No

10. Did you notice any difference in improvement of the shooter at faster rate than the other shooters in your group? (circle one): Yes No

11. Any additional comments.

## LIST OF REFERENCES

- Annual Rifle Training ART-A.14, (2008). *Rifle table 1 course of fire*. Weapons Training Battalion, Quantico, VA.: Marine Corps Combat Development Command.
- Baggett, P., & Ehrenfeucht, A. (1988). Conceptualizing in assembly tasks. *Human Factors*, 30, 269–284.
- The Basic School (TBS) Marksmanship Student Outline, 2011. *Introduction to Marine Corps combat marksmanship*. [PowerPoint slides]. Quantico, VA: Marksmanship Training Company, Weapons Training Battalion.
- Becker, W. (2010) *Marine Corps small arms and marksmanship training: Thrust technical review*. [PowerPoint slides] Arlington, VA: Office of Naval Research.
- Chi, M. T. H., Siler, S. A., & Jeong, H. (2004). *Can tutors monitor students' understanding accurately*. University of Pittsburg, Pittsburg, PA.: Learning Research and Development Center.
- Chung, K. W., Delacruz, G. C., dVries, L. F, Bewley, W. L., & Baker, E. L. (2006). New directions in rifle marksmanship research. *Military Psychology*. 18(2), 161–179.
- Combat Marksmanship Course. (2006). *Introduction to Marine Corps rifle marksmanship*. Quantico, VA.: Weapons Training Battalion, Marine Corps Combat Development Command.
- Combat Marksmanship Coach's Course CMC.20. (2006). *Analyzing the fundamentals of rifle marksmanship*. Quantico, VA: Marine Corps Marksmanship Center of Excellence. Marine Corps Combat Development Command.
- Combat Marksmanship Symposium (CMS) Record of Proceedings (ROP). (2011). *Rifle combat optic (RCO) Test*. Quantico, VA: Weapons Training Battalion, Marine Corps Combat Development Command.
- Drury, C. G., & Clement, M. R. (1978). The effect of area, density, and number of background characters on visual search. *Human Factors*, 20, 597–602.
- Fitts, P. M., & Posner, M. I. (1967). *Basic concepts in psychology series: human performance*. Belmont, CA: Brooks/Cole Company. 2, 8–25.

- Fleet Marine Force Manual FMFM 0–9 (1995). *Field firing for the M16A2 service rifle*. Washington, DC: Headquarters United States Marine Corps. Chapters 1–13.
- Infantry: combat simulators for the infantry*. (2008). Strategy. Retrieved September 1, 2011, from [strategypage.com](http://strategypage.com):
- Kalyuga, S., Chandler, P., & Sweller, J. (1998). Levels of expertise and instructional design. *Human Factors*, 40, 1–17.
- Krulak, C. C. (1997). *MCDP 1–3: Tactics*. Washington, DC: Headquarters United States Marine Corps.
- Marine Corps Order MCO 3574.2K. (2007). *Marine Corps combat marksmanship programs*. Washington, DC: Headquarters United States Marine Corps.
- Marine Corps Website, (2011). Image Archive. Retrieved September 18, (2011), from <http://192.156.19.109/marinelink/image1.nsf/imagearchive?OpenForm&Start=535>
- NAVMC 42. (2011). *Annual rifle training databook service rifle/carbine: iron sights*. Retrieved September 18, (2011), from <http://www.tecom.usmc.mil/wtbn/MainPageBase/default.asp>
- Powers, J. J., & Platte, W. J. (2008). *Using motion capture*. Monterey, CA: Modeling, Virtual Environments and Simulations (MOVES), Naval Postgraduate School.
- Richardson, M., Jones, G., Torrance, M., & Baguley, T. Identifying the task variables that predict object assembly difficulty. *Human Factors: The Journal of the Human Factors and Ergonomics Society* 2006, 48, 511
- Scribner, D. R., Wiley, P. H., & Harper, W. H. (2007). *A comparison of live and simulated fire soldier shooting performance*. U.S. Army. Aberdeen Proving Ground, MD: Army Research Laboratory.
- Student Outline 0300-M16–1004 (2008). *Zeroing the service rifle/carbine*. Parris Island, S.C.: Marine Corps Recruit Depot/Eastern Recruiting Region.
- Tactical Electronics & Military Supply LLC. (2007). Retrieved September 1, (2011), from <http://www.tacticalectronics.com/products/21/products/62/weapon-mounted-cameras/90/split-shot-scope-transmitter>

Yates, W. W. (2004). *A training transfer study of the indoor simulated marksmanship trainer*. Modeling, Virtual Environments and Simulations (MOVES) Department, Naval Postgraduate School.

THIS PAGE INTENTIONALLY LEFT BLANK



## INITIAL DISTRIBUTION LIST

1. Defense Technical Information Center  
Ft. Belvoir, Virginia
2. Dudley Knox Library  
Naval Postgraduate School  
Monterey, California