



**NAVAL
POSTGRADUATE
SCHOOL**

MONTEREY, CALIFORNIA

THESIS

**IMPROVING HEALTH-CARE DELIVERY FOR
POST-TRAUMATIC STRESS DISORDER:
AN INTERRELATED APPROACH LEVERAGING
SYSTEMS ENGINEERING AND OPTIMIZATION**

by

Scott Alexander McKenzie

September 2011

Thesis Advisor:

Douglas MacKinnon

Thesis Co-Advisor:

John Osmundson

Approved for public release; distribution is unlimited

THIS PAGE INTENTIONALLY LEFT BLANK

REPORT DOCUMENTATION PAGE			Form Approved OMB No. 0704-0188	
Public reporting burden for this collection of information is estimated to average 1 hour per response, including the time for reviewing instruction, searching existing data sources, gathering and maintaining the data needed, and completing and reviewing the collection of information. Send comments regarding this burden estimate or any other aspect of this collection of information, including suggestions for reducing this burden, to Washington headquarters Services, Directorate for Information Operations and Reports, 1215 Jefferson Davis Highway, Suite 1204, Arlington, VA 22202-4302, and to the Office of Management and Budget, Paperwork Reduction Project (0704-0188) Washington DC 20503.				
1. AGENCY USE ONLY (Leave blank)		2. REPORT DATE September 2011	3. REPORT TYPE AND DATES COVERED Master's Thesis	
4. TITLE AND SUBTITLE Improving Health-care delivery for Post-Traumatic Stress Disorder: An Interrelated Approach Leveraging Systems Engineering and Optimization			5. FUNDING NUMBERS	
6. AUTHOR(S) Scott Alexander McKenzie				
7. PERFORMING ORGANIZATION NAME(S) AND ADDRESS(ES) Naval Postgraduate School Monterey, CA 93943-5000			8. PERFORMING ORGANIZATION REPORT NUMBER	
9. SPONSORING /MONITORING AGENCY NAME(S) AND ADDRESS(ES) N/A			10. SPONSORING/MONITORING AGENCY REPORT NUMBER	
11. SUPPLEMENTARY NOTES The views expressed in this thesis are those of the author and do not reflect the official policy or position of the Department of Defense or the U.S. Government. IRB Protocol number _____N.A._____.				
12a. DISTRIBUTION / AVAILABILITY STATEMENT Approved for public release; distribution is unlimited			12b. DISTRIBUTION CODE	
13. ABSTRACT (maximum 200 words) Post-Traumatic Stress Disorder (PTSD), major depression, anxiety disorders, and other post-deployment adjustment difficulties affect a significant number of veterans returning from Operation Iraq Freedom and Operation Enduring Freedom. To contend with this new influx of veterans suffering from the psychological aftermath of military combat, the VA has been proactive, including commissioning this study of their PTSD health-care delivery system. Its objective is to provide the best care, in the most efficient manner possible to as many affected veterans as possible. This study examines PTSD health-care delivery from a systems engineering perspective. It employs state-of-the-art tools such as: ExtendSim modeling and simulation software, and JMP analysis software. The resulting models produce a set of eight optimized system factors, which maximize the desirability of four system performance measures that define the efficiency, capacity, and timeliness of the system. We argue that these models can and should be used as a platform for future work in this area of study.				
14. SUBJECT TERMS PTSD, Post Traumatic Stress Disorder, Systems Engineering, Optimization, ExtendSim, VDT Power, JMP, Excel, Health-care delivery, Veteran's Affairs, VA			15. NUMBER OF PAGES 79	
			16. PRICE CODE	
17. SECURITY CLASSIFICATION OF REPORT Unclassified	18. SECURITY CLASSIFICATION OF THIS PAGE Unclassified	19. SECURITY CLASSIFICATION OF ABSTRACT Unclassified	20. LIMITATION OF ABSTRACT UU	

THIS PAGE INTENTIONALLY LEFT BLANK

Approved for public release; distribution is unlimited

**IMPROVING HEALTH-CARE DELIVERY FOR POST-TRAUMATIC STRESS
DISORDER: AN INTERRELATED APPROACH LEVERAGING SYSTEMS
ENGINEERING AND OPTIMIZATION**

Scott Alexander McKenzie
Civilian, Department of the Navy
B.S., Mississippi State University, 2002

Submitted in partial fulfillment of the
requirements for the degree of

MASTER OF SCIENCE IN SYSTEMS ENGINEERING MANAGEMENT

from the

**NAVAL POSTGRADUATE SCHOOL
September 2011**

Author: Scott Alexander McKenzie

Approved by: Douglas MacKinnon, PhD
Thesis Advisor

John Osmundson, PhD
Thesis Co-Advisor

Cliff Whitcomb, PhD
Chair, Department of Systems Engineering

THIS PAGE INTENTIONALLY LEFT BLANK

ABSTRACT

Post-Traumatic Stress Disorder (PTSD), major depression, anxiety disorders, and other post-deployment adjustment difficulties affect a significant number of veterans returning from Operation Iraq Freedom and Operation Enduring Freedom. To contend with this new influx of veterans suffering from the psychological aftermath of military combat, the VA has been proactive, including commissioning this study of their PTSD health-care delivery system. Its objective is to provide the best care, in the most efficient manner possible to as many affected veterans as possible.

This study examines PTSD health-care delivery from a systems engineering perspective. It employs state-of-the-art tools such as: ExtendSim modeling and simulation software, and JMP analysis software.

The resulting models produce a set of eight optimized system factors, which maximize the desirability of four system performance measures that define the efficiency, capacity, and timeliness of the system. We argue that these models can and should be used as a platform for future work in this area of study.

THIS PAGE INTENTIONALLY LEFT BLANK

TABLE OF CONTENTS

I.	INTRODUCTION.....	1
	A. BACKGROUND	1
	B. RESEARCH QUESTIONS	3
	1. Main Research Question	3
	2. Supporting Research Questions	3
	C. SYSTEMS ENGINEERING APPROACH	3
	1. Define the Problem	4
	2. Identify and Analyze Mission and Environments.....	4
	3. Identify and Decompose Functional Requirements.....	5
	4. Quantify Processes	6
	5. Define System Attributes and Measures.....	7
	6. Construct Model.....	8
	<i>a. VDT Power</i>	<i>8</i>
	<i>b. Microsoft Excel</i>	<i>8</i>
	<i>c. ExtendSim</i>	<i>9</i>
	7. Verify Model.....	9
	8. Design of Experiments (DOE) and Analysis of Results.....	10
	<i>a. Determine Design Factors and Levels</i>	<i>10</i>
	<i>b. Select Orthogonal Array</i>	<i>10</i>
	<i>c. Probabilistic Design</i>	<i>10</i>
	<i>d. Conduct Experiment and Analyze Data (ExtendSim v7 and Excel).....</i>	<i>11</i>
	<i>e. Program and Conduct Experiment (ExtendSim v8).....</i>	<i>11</i>
	<i>f. Create JMP Model</i>	<i>12</i>
	D. SCOPE OF THIS THESIS.....	12
	E. BENEFITS OF THIS STUDY	12
II.	SYSTEM DESCRIPTION	15
	A. OVERVIEW	15
	B. RECEIVE PATIENT	17
	1. Receive Referral.....	17
	2. Schedule Assessment.....	18
	C. ASSESS PATIENT	18
	1. Perform Assessment.....	18
	2. Establish Diagnosis	18
	3. Create Treatment Plan	18
	D. PREPARE PATIENT FOR TREATMENT.....	18
	1. Scaffolding	18
	E. PROVIDE TREATMENT	19
	1. Prolonged Exposure.....	19
	2. Cognitive Processing Therapy	19
	3. Care Management.....	20

	4.	Medication Management.....	20
F.		DISENGAGE	20
G.		CONTINUOUSLY IMPROVE	20
	1.	Maintain Patient History.....	20
	2.	Monitor Performance and Effectiveness	21
	3.	Adjust Process	21
III.		OPERATIONAL MODEL.....	23
A.		MODEL DEVELOPMENT AND IMPLEMENTATION	23
	1.	Providers.....	23
	a.	Work Schedule	23
	b.	Provider Quantity.....	23
	c.	Utilization	23
	2.	Patients.....	24
	a.	Rate of Arrival.....	24
	b.	Rate of Drop	24
	3.	Assessments	25
	4.	Establishing Diagnoses	25
	5.	Distribution of Treatment Plan Types	26
	a.	General.....	26
	b.	Traditional Therapy	26
	c.	EBT.....	26
	6.	Scaffolding	27
	7.	Provider Intensity	27
	8.	Structure of Therapies.....	28
	a.	PE	28
	b.	CPT.....	28
	c.	Care Management.....	28
	d.	Medication Management.....	28
	9.	Patient-Provider Encounters	29
	a.	Patient Cancellation.....	29
	b.	Encounter Failure	30
B.		SUMMARY OF FACTORS, RESPONSES, AND EXPERIMENTAL DESIGN	31
	1.	Factors.....	31
	2.	Responses	32
C.		RESULTS	32
IV.		ANALYSIS	33
A.		JMP MODEL	33
B.		PREDICTION PROFILER	33
	1.	Interpreting Factors and Responses.....	34
	2.	Interpreting System Sensitivities	35
C.		DESIRABILITY FUNCTIONS (OPTIMIZATION)	35
D.		FACTORS OPTIMIZED FOR MAXIMUM DESIRABILITY	36
	1.	Optimized Factor Settings.....	36
	2.	Actual vs. Expected Results	37

	a.	<i>Provider Count</i>	37
	b.	<i>Provider Intensity</i>	37
	c.	<i>CPT and CM Group Sizes</i>	37
	d.	<i>Scaffolding Session Count</i>	37
	e.	<i>Cancellation, Failure, and Drop Rates</i>	38
	3.	Optimal Responses (Maximized Desirability)	38
	4.	System Improvements Gained Over Base Case	38
V.		CONCLUSIONS AND RECOMMENDATIONS	41
	A.	SECONDARY RESEARCH QUESTIONS	41
		1. Definition of <i>Efficiency</i> in PTSD Health-care delivery	41
		2. Definition of <i>Capacity</i> in PTSD Health-care delivery	41
		3. Definition of <i>Quality</i> in PTSD Health-care delivery	41
	B.	PRIMARY RESEARCH QUESTION	41
	C.	OBJECTIVE ACHIEVEMENT	42
	D.	SUMMARY OF RECOMMENDATIONS FOR FUTURE WORK	43
		1. Validate the Models	43
		2. Improve the Measurement of <i>Quality</i>	43
		3. Improve the Modeling of Human Resources	43
		4. Improve the Alignment of the Models with Reality	43
		5. Improve VA Data Tracking and Presentation	44
		APPENDIX A: EXTENDSIM SCREEN SHOTS	45
		APPENDIX B: JMP MODEL FIT STATISTICS	49
		LIST OF REFERENCES	53
		INITIAL DISTRIBUTION LIST	55

THIS PAGE INTENTIONALLY LEFT BLANK

LIST OF FIGURES

Figure 1.	Functional decomposition of PTSD health care	5
Figure 2.	Basic flowchart for PTSD health-care delivery	15
Figure 3.	Expanded flowchart for PTSD health-care delivery	15
Figure 4.	Cross-functional flowchart for the system of PTSD health-care delivery	17
Figure 5.	JMP prediction profiler (including maximized desirability functions).....	34
Figure 6.	Extend Sim Model of PTSD System (Entire View)	46
Figure 7.	Control section of ExtendSim model.....	47
Figure 8.	Receive, assess, and prepare functions represented in ExtendSim model.....	47
Figure 9.	Traditional therapy represented in ExtendSim model	47
Figure 10.	Medication management represented in ExtendSim model.....	47
Figure 11.	Detail of “Prepare Patient” block seen in Figure 6.	48
Figure 12.	Actual provider utilization responses predicted by JMP model	51
Figure 13.	Actual quantity complete responses predicted by JMP model	51
Figure 14.	Actual average treatment duration responses predicted by JMP model	52
Figure 15.	Actual average time-between-encounters responses predicted by JMP model.....	52

THIS PAGE INTENTIONALLY LEFT BLANK

LIST OF TABLES

Table 1.	System improvements gained using optimized factors over base case.....	xix
Table 2.	Comparison of base and optimal factors.....	xx
Table 3.	Mapping functions to physical components	16
Table 4.	Definition of probabilistic design levels for patient drop rate	24
Table 5.	Definition of probabilistic design levels for provider intensity	27
Table 6.	Definition of probabilistic design levels for patient cancellation rate	30
Table 7.	Definition of probabilistic design levels for encounter failure rate	31
Table 8.	Summary of experiment factors.....	32
Table 9.	Summary of experiment responses	32
Table 10.	Desirability table for system responses.....	36
Table 11.	Optimal factors, as determined by JMP to maximize desirability functions ...	36
Table 12.	Simulation responses resulting from optimal factors.....	38
Table 13.	Comparison of base and optimal factors.....	39
Table 14.	System improvements gained using optimized factors over base case.....	39
Table 15.	Optimized factors.....	42
Table 16.	JMP model fit statistics.....	50

THIS PAGE INTENTIONALLY LEFT BLANK

LIST OF ACRONYMS AND ABBREVIATIONS

BH	Behavioral Health
CBOC	Community-Based Outpatient Clinic
CPT	Cognitive Processing Therapy
DISE	Distributed Information Systems Experimentation
EBT	Evidence-Based Treatment
GMC	General Medical Clinic
ICD	International Statistical Classification of Diseases and Related Health Problems
MH	Mental Health
MHC	Mental Health Clinic
MOP	Measures of Performance
NPS	Naval Postgraduate School
NCPTSD	National Center for PTSD
OEF	Operation Enduring Freedom
OI&T	Office of Information and Technology
OIF	Operation Iraqi Freedom
PCT	PTSD Clinical Team
PE	Prolonged Exposure
PTSD	Post-Traumatic Stress Disorder
VA	United States Department of Veteran Affairs
VAPAHCS	VA Palo Alto Health-care system
VDT	Virtual Design Team
VistA	Veterans Health Information Systems and Technology Architecture

THIS PAGE INTENTIONALLY LEFT BLANK

EXECUTIVE SUMMARY

Post-Traumatic Stress Disorder (PTSD), major depression, anxiety disorders, and other post-deployment adjustment difficulties affect a significant number of veterans returning from Operation Iraq Freedom and Operation Enduring Freedom. To contend with this new influx of veterans suffering from the psychological aftermath of military combat, the VA has been proactive, including commissioning this study of their PTSD health-care delivery system, with the objective of providing the best care in the most efficient manner possible to as many affected veterans as possible.

This study examines PTSD health-care delivery from a systems engineering perspective. First, a comprehensive study of the system of PTSD health-care delivery was completed. This included identification and analysis of the mission and the environments, identification and decomposition of functional requirements, the quantification of system processes, and the identification of systems attributes and measures.

The main functions of the system were determined to be: “cure people” and “continuously improve.” Under *cure people*, the main work of PTSD occurs. The sub-functions for *cure people* are receive patient, assess patient, prepare patient for treatment, provide treatment, and disengage. Under *continuously improve* are the administrative sub-functions maintain patient history, monitor performance, and adjust process.

The characterization of the system was completed with the mapping of functions to form and the creation of a cross-functional flowchart.

Armed with this information, the work of creating a usable model of the system began to answer the research question, “For the system of PTSD Health-care delivery, what are optimal factors that will maximize efficiency, capacity, and quality?” State-of-the-art tools, including ExtendSim modeling/simulation software and JMP analysis software were employed (JMP Ver 9.0.0 and ExtendSim Suite Ver. 8.0.1).

Each subfunction was decomposed into the major tasks required to support the functional requirement. Then, over numerous discussions with the sponsor, the

parameters of each task were determined in sufficient detail so that they could be represented in the ExtendSim model. ExtendSim 8 was used, which provides a powerful tool (Scenario Manager) for the design of experiments.

Using Scenario Manager, an experiment was designed around eight factors and four responses. Six factors were evaluated over three levels, and the remaining two factors were evaluated over two levels.

The eight factors of the system are number of health care providers, provider intensity (number of providers required per patient encounter), group sizes for two separate forms of therapy, number of sessions provided to prepare patients for intense therapy, patient cancellation rate, encounter failure rate, and patient drop rate.

The four responses were provider utilization (measures efficiency), patient throughput (measures capacity), average treatment duration (measures timeliness) and average time-between-encounters (also measures timeliness). For this thesis, timeliness represents quality of service in the delivery of PTSD health care. Maximizing quality equates to providing the best care. From the standpoint of measuring quality, important future work would incorporate efficacy for the various treatment paths into the model.

The resulting ExtendSim model was programmed to simulate 260 weeks (approximately five years) of system operation. The amount of time allowed for the system to reach equilibrium averaged 26 weeks (approximately 10% of the simulation time). Note that a full-factorial experiment design would include $(3^6)(2^2) = 2916$ scenarios. With three trials per scenario, there are 8748 separate trials. This would not have been practicable without the Scenario Manager feature of ExtendSim 8.

The results were automatically recorded to a table within Scenario Manager. Scenario Manager then exported the table to JMP for analysis.

Using the Fit Model platform within JMP and invoking the Prediction Profiler, a response curve was generated for each factor-response combination. Then, a desirability function was created for each response. Executing the maximize desirability command

within JMP produced a set of eight optimized system factors, which maximize the desirability of four system performance measures that define the efficiency, capacity, and timeliness of the system.

The improvements in system performance gained by using optimal factors over the base case were notable. These improvements are summarized in Table 1. Note that all system attributes are improved, and that an 80% improvement in overall system desirability can be theoretically achieved.

Attribute	Measured Response	Base	Optim	Delta	% Improve
Efficient	Provider Utilization	0.61	0.88	0.27	44%
Capacity	Throughput (patients)	270	310	40	15%
Timely	Treatment Duration (weeks)	17.6	10.0	-7.6	43%
Timely	Time Between Encounters (weeks)	2.30	1.58	-0.72	31%
Overall System Desirability		0.49	0.88	0.39	80%

Table 1. System improvements gained using optimized factors over base case

These improvements are obtainable by altering the system factors from base to optimal as described in Table 2. Note that optimal factors for *provider count*, *scaffolding session count*, *cancellation rate*, *failure rate*, and *drop rate* were expected, while those for *provider intensity* and *CPT/CM group size* were not expected.

#	Factor	Base	Optim
1	Provider Count	2	2
2	Provider Intensity	Base	Base
3	CPT Group Size	9	1
4	CM Group Size	9	1
5	Scaffolding Session Count	4	3
6	Cancellation Rate	Base	Less
7	Failure Rate	Base	Least
8	Drop Rate	Base	Less

Table 2. Comparison of base and optimal factors

We argue that these models can and should be used as a platform for future work in this area of study. They are valuable tools for real-world decision-making. Enhancing the accuracy and scope of these models will speed the rate of improvement to the overall system of PTSD health-care delivery.

ACKNOWLEDGMENTS

“We’re never so vulnerable than when we trust someone—but paradoxically, if we cannot trust, neither can we find love or joy.” —Walter Anderson

To Harley Barber, for all the time and effort you spent querying VistA. You are a true professional—always willing to do “what it takes.” Thank you also for your life of service to our country.

To Josef Ruzek and Steven Lindley, for the guidance and feedback during all those Friday teleconferences and the occasional face-to-face meeting. Thank you for your unwavering service to the men and women suffering from PTSD. Your efforts are so important to improving their plight.

To all the Monterey CBOC personnel, especially Beth and Katranker.

To Doug MacKinnon and John Osmundson, for your subtle-yet-highly-effective guidance. More than anything, your expressed faith in my abilities inspired me.

To Shelley Gallup, for the “slide.”

To Gordon Schacher, the “burning bush” of wisdom and insight in all things experimentation. I will forever be your student.

To Melissa McKenzie, my faithful and supportive wife.

To Julie Harper, for the innumerable hours of work it took to transfer money from the VA to NPS. It was a little easier the second time, but still difficult. Thank you for your persistence.

To Sharon McNally, for handling the money on this end of things. I know and appreciate what you go through every day.

To Jade DePalacios, for encouraging me when I was content to procrastinate.

To Tomas Sabinella, for making the heavy things light.

To Dayton Hughes, for being a great friend.

THIS PAGE INTENTIONALLY LEFT BLANK

I. INTRODUCTION

What cannot be talked about cannot be put to rest. And if it is not, the wounds will fester from generation to generation.

—Bruno Bettelheim

A. BACKGROUND

Post-Traumatic Stress Disorder (PTSD), major depression, anxiety disorders, and other post-deployment adjustment difficulties affect a significant number of veterans returning from Operation Iraq Freedom (OIF) and Operation Enduring Freedom (OEF). For example, it is estimated that up to 28% of those who served in OIF/OEF would meet the diagnostic criteria of PTSD if broader screening criteria were used (Hoge, Castro, Messer, McGurk, Cotting, & Koffman, 2004).

The VA has taken a proactive approach to dealing with a new influx of veterans suffering from the psychological aftermaths of military combat. These measures have included expanding outreach efforts to veterans in the community, integrating mental health care within the primary care setting to decrease stigma and improve access, and instituting universal mental health screenings. According to statistics gathered from the Veterans Health Information Systems and Technology Architecture (VistA), within the Palo Alto VA Health-care system (HCS), approximately 80 veterans screen positive for PTSD per month of which 72% have not had mental health care within the last two years. These numbers indicate that accurate, comprehensive tracking of patients from diagnosis to outpatient care is integral part of helping these veterans.

Treatment options in VA for patients with PTSD range widely in duration and clinician involvement. They include: include psychoeducation, motivational interviewing/behavioral activation, web-based self-help, time-limited group therapy, short-term individual therapy and psychopharmacological treatments (DCOE for Psychological Health & Traumatic Brain Injury, 2011).

In terms of health-care delivery, the goal is to provide the most appropriate, effective and least intrusive intervention as soon as possible to the greatest number of affected individuals possible. For patients with moderate to severe PTSD whom do not respond to very brief interventions, forms of individual therapy known as Prolonged-Exposure (PE) and Cognitive Processing Therapy (CPT) are currently the “gold standards.” Both of these therapies have significant amounts of empirical support for their effectiveness (Monson, Schnurr, Resick, Friedman, Young-Xu, & Stevens 2006) (Schnurr, Friedman, Engel, Foa, Shea, Chow, Resick, Thurston, Orsillo, Haug, Turner, & Bernardy 2007). Both therapies, however, are time-intensive (e.g., PE is most often administered in twelve, 90 minute sessions). Like all therapies, there is a variable response to exposure-based therapies and many patients will require continuing mental health care even after the best available interventions are administered. And, acuity of presentation will, of course, factor into clinical decision-making regarding frequency/intensity of provider intervention.

To respond to new guidelines mandating the provision of state-of-the-art, research-based PTSD intervention, mental health staffing has been expanded, but increased staffing alone will be insufficient without other, more systemic changes in clinical practice (Department of Veterans Affairs, 2010).

These changes include improvements in office efficiency to enhance timely access of care, track patient status from inpatient to outpatient care, improved coordination of care between providers, decreases in treatment barriers, increases in effective initial treatment assignments, and enhanced efficiency of chronic care to reduce staff burden and maximizing staff productivity. *The objective is to provide the best care in the most efficient manner possible to as many affected veterans as possible.* However, without a systems approach to this goal, it is unlikely to be achieved.

Further, challenges inherent to the treatment of PTSD in veterans (e.g., resistance to change due to identity issues or to compensation seeking) must be factored into any algorithm addressing system performance in this arena.

B. RESEARCH QUESTIONS

1. Main Research Question

While the answer may be somewhat elusive, the question to be asked is readily apparent. In short, it is, “For the system of PTSD Health-care delivery, what are optimal factors that will maximize efficiency, capacity, and quality?”

2. Supporting Research Questions

To answer the main research question, it will be necessary to define some terms. Specifically, the definitions of *efficiency*, *capacity*, and *quality* must be defined. Therefore the supporting research questions are:

- What defines *efficiency* in PTSD Health-care delivery?
- What defines *capacity* in PTSD Health-care delivery?
- What defines *quality* in PTSD Health-care delivery?

C. SYSTEMS ENGINEERING APPROACH

A systems engineering (SE) methodology provides structure through which complex systems may be examined. In a purely developmental project, the starting point would begin with a definition of the problem to be solved or a requirement to be met. In a re-engineering project, this beginning point is a requirement to improve the performance of a complex system already in place. In this case, “system” refers to people, technology, policy, tools and techniques, which are interrelated for the purpose of doing the work required to meet required measures of performance.

The development of a working model, or simulation, reveals the specific factors to which the system is most sensitive. The assumption is that PTSD health care includes many aspects of a dynamic system that are best understood in a working simulation that includes the relationships and interactions between all of the working components of the system.

While the SE approach is broadly methodical and leads to a reliable solution, there remains an infinite variety within the path of the research, due to the myriad of tools available to today's systems engineer. As part of the research work, an investigation of these tools and their suitability to the problem was accomplished. In this section, a chronology of the research is provided. Some of this narrative describes that of the overarching SE approach, and some of it is the investigation of various tools and their suitability to this particular project.

1. Define the Problem

The problem presented itself during several discussions with principal investigators from the VA: Drs. Josef Ruzek and Steven Lindley. The discussions were summarized in the paragraph entitled "Background" and the problem was consolidated into the research questions presented previously.

2. Identify and Analyze Mission and Environments

The next phase of the systems engineering approach was applied to the investigation of the work of the PTSD health care providers within the environment of the VA Health-care system (VAHCS). As the VAHCS is distributed nation-wide across dozens of clinics, a single clinic was chosen to represent the system.

The Monterey Community-Based Outpatient Clinic (CBOC) was an obvious choice as the subject for case study. The clinic serves the populations of the Monterey peninsula, south to Big Sur, CA, and north to Gilroy, CA. The clinic served 1480 mental health and 5597 primary care patients in FY 2008. In terms of patients served and staffing levels, its falls into a "medium" size range for clinics in VAPAHCS. Similar to most of the VA clinics, it is geographically isolated from residential and other specialty treatment providers. It is the site of a PTSD Clinical Team (PCT), comprised of a psychologist, a social worker, and a recreational therapist. These factors make it representative of other VAPAHCS CBOCs, and appropriate to serve as the test site for the project. In addition, it treats a diverse population: former military, active duty,

National Guard and Reserve personnel. It is approximately 5 miles from the Naval Postgraduate School (NPS), making it a logical choice due to its proximity.

Data was gathered for the purpose of defining specific problems apart from systems-related symptoms. Types of data collected included those obtained through interview and observation, acquired from people who are engaged in work within the system. A dozen health care providers were interviewed. Each provider was asked to relate their typical workday, the segment of the PTSD population they served and in what capacity they served them, and specific challenges that are associated with their work.

3. Identify and Decompose Functional Requirements

Categorizing functional areas and their relationships to people, technology, policy, or health care schemas was necessary for development of the working model of the system. The process of codifying the basic functions of the system began as a distillation of the interview notes. Functions were then decomposed and presented to the VA for validation prior to the commencement of model development efforts. Figure 1 shows the results of the functional decomposition.

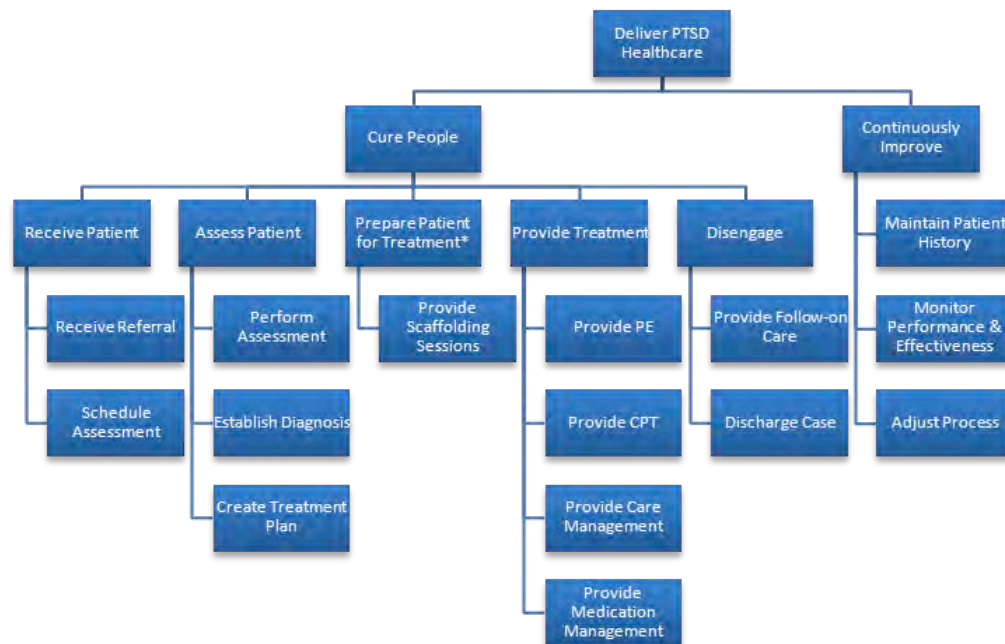

Figure 1. Functional decomposition of PTSD health care

The functional requirements of a system that delivers PTSD health care can be divided into two broad categories. The first is the function of curing people of their PTSD. The word “cure” may be a misnomer, because most people will never become fully cured; this is due to the nature of the disorder. “Treat” could be substituted for “cure,” but the ultimate desire is for people to lead a PTSD-free life, so “cure” is used.

The second major functional category is to continuously improve. This category contains all of the administrative functions that are not directly related to providing treatment and curing people. The title of this functional category was specifically chosen to represent the true purpose of the sub-functions that it contains. Of course, PTSD therapy can be delivered without the tedium of tracking patients (either individually or on the aggregate) but, to gain improvements to the system these things must be done. Moreover, collecting data but not using it in a meaningful way to improve the success rate of PTSD health care (i.e., refining the correlation between key factors and measures) would not be responsible to the overarching function of delivering PTSD health care. Similarly, collecting the wrong or insufficient information does not help to advance the system performance and therefore does not support the overarching function. Lastly, the information, even if correct and complete, must be easily accessible and readily usable.

4. Quantify Processes

Considerable time was spent in consultation with Mr. Harley Barber, a VA information system specialist, to gather baseline statistics of the system. In the process, it was discovered that the VistA information system is not (currently) adequately tracking PTSD system metrics.

Data was captured (with some level of difficulty) that characterized the system parameters. Aggregate statistics were used for model development. As there is considerable variety, both in the severity of PTSD from patient to patient and the treatment paths prescribed, consultation with the research sponsor was necessary to form a backdrop to the statistics. The problem was compounded by the efforts to transform and standardize treatment paths. In other words, should a model be built to represent the current state of a system in transition (a very complicated process), or should it be based

on the desired end-state of the system (a more achievable, and possibly more useful goal)? The decision was made in favor of the latter.

5. Define System Attributes and Measures

Recall the main research question: *For the system of PTSD Health-care delivery, what are optimal factors that will maximize efficiency, capacity, and quality?* The key responses are in the realms of efficiency, capacity, and quality.

Efficiency implies efficiency of resources used in the system. The resources in PTSD health care are mainly human resources (viz., health care providers). Efficiency in the use of human resources can be measured in *Utilization*. Simply put, utilization is the percentage of the providers' available time that is spent engaged in the provision of PTSD health care.

Capacity is easily measured as the number of patients processed by the system over a period of time.

Standards of quality are measured from the patient's perspective. A patient suffering from PTSD might judge quality by the frequency of provider contact and the speed of recovery. For instance, if a treatment plan calls for provider-patient contact on a weekly basis, but because the clinic is understaffed, the patient sees the provider every three, the quality of care might be deemed to be low. In this case, the situation could lead to patient disillusionment or apathy, resulting in increased patient drop rates, for example. The same argument applies to speed of recovery.

Provider contact frequency is easily measured in the model by tracking and averaging the times-between-encounters. Speed of recovery can be measured in the model by tracking and averaging the delta of entry to and exit from the system for each patient. These are both measurements that quantify an attribute of the system that could be called *timeliness*. Therefore, *quality*, in one sense of the case of PTSD health care, is defined by how *timely* the care is.

Timeliness is not the only quality attribute of PTSD health-care delivery. If it were, that would assume that every patient exiting the system has the same level of

recovery from his or her disorder. Future work should compare the entrance and exit PTSD scores from standardized psychological tests and incorporate the efficacy of treatment plans into the model.

6. Construct Model

A key goal of the research was to construct a working model of the system. This task was attempted using a variety of tools. VDT Power and Excel both produced working models, but ultimately ExtendSim provided the most robust model with the greatest flexibility.

a. VDT Power

A model was built using VDT Power, given workload as stated by the providers. VDT Power is an excellent tool for single, start-to-finish projects, particularly when inter-functional communication is important to the performance of the system. It was difficult to apply VDT to multiple, asynchronous, and disparate projects (viz., individual patients receiving individualized treatment in overlapping time domains). VDT Power focuses on “information flow physics” in projects where “all activities in the project can be predefined” (Levitt, 2009).

b. Microsoft Excel

A standard tool for smaller problems in operations research is Microsoft Excel, in conjunction with the Solver add-in by Frontline Systems, Inc. An Excel model of the system was constructed that incorporated many of the system parameters. Using Solver, the model was optimized for lowest provider cost. When multiple responses are presented, as in the PTSD health care system, use of Solver and Excel becomes tedious and impracticable. For this reason, the Excel model was abandoned and construction in ExtendSim began.

c. ExtendSim

For this modeling effort, ExtendSim presented itself as the most appropriate tool. ExtendSim is a software product that enables the building-block style creation of discrete event models that represent real-life processes. ExtendSim supports the creation of shift schedules, which are useful in describing the availability of health care providers. The software supports database communication, allowing the user to pre-define a set of experimental parameters from one set of tables, and then record the results to another set of tables. In addition, version 8 of ExtendSim presents excellent interoperability with the JMP analysis tool, which became an important part of this research.

The modeling process began as a simple approximation of the functional requirements. During numerous conferences with the research physicians from the VA, and through analysis of encounter data provided by the VA, the model was quantified and refined until, after several iterations, it was accepted as a useful approximation of the actual system. The resulting model is a dynamic simulation that mathematically describes the behavior of the system of PTSD health-care delivery over time.

A version of the model was constructed in version 7 of ExtendSim. The model was then upgraded to version 8, which greatly improved the design of experiments functionality.

7. Verify Model

The ExtendSim model was verified by comparing the results of one scenario with those obtained through manual (Excel) number-crunching. The model was deemed to be mathematically accurate.

8. Design of Experiments (DOE) and Analysis of Results

a. Determine Design Factors and Levels

Design factors became evident in the model as the parameters of the system functions that might be considered “controllable” in the real world. For each factor, a set of levels was designed, under consultation with VA physicians. These levels represented incremental, obtainable, improvements to the real-world system.

b. Select Orthogonal Array

The number of combinations of factors and levels being too high for an exhaustive, full-factorial, manual execution, a suitable orthogonal array was found from listings of predesigned arrays. With an orthogonal array, a subset of level combinations was required that would avoid significant loss of experiment integrity. A predesigned orthogonal array was chosen that would provide 24 factor scenarios.

c. Probabilistic Design

Included in the DOE are probabilistic design factors. In the simplest terms, probabilistic design allows the factors to become more than numeric variables. With the incorporation of probabilistic design into the model, some of the factors are represented by distributions. In the case of this research in its current state, all distributions are empirical. Future work should include a more detailed analysis of the data. This may uncover smoother distributions that may result in an improved representation of reality.

d. Conduct Experiment and Analyze Data (ExtendSim v7 and Excel)

Using ExtendSim version 7, the factor levels were manually manipulated. Multiple (5) trials of each experimental unit were completed, to ensure that the results were corrected for randomness. After each trial, the resulting values for the measures were manually recorded to a response table. The manual execution of the experiment required approximately 3.5 hours to complete.

Then, using Excel to analyze the response table, for each experimental unit and for each measure, an average of the 5 trials was computed. An average was computed across experimental units, within each parameter and level. The results, displayed in response curves, were the combined main effects of changing parameter levels on the system performance measures.

e. Program and Conduct Experiment (ExtendSim v8)

The tedious process of conducting the experiment was automated with the implementation of the model in version 8 of ExtendSim, which increased the experimental budget significantly. Using Scenario Manager, the experiment simply needed to be programmed into ExtendSim. Execution was automatic, requiring no human interaction. Analysis of the resulting table of responses was greatly simplified using Scenario Manager's interoperability with JMP.

As result, the design was improved to a full-factorial experiment. A full-factorial scheme of the experiment's 2916 design points was executed, at three trials each, for a total of 8748 runs of the model. Once Scenario Manager was fully programmed, the experiment was executed, without further input, over a period of four hours.

f. Create JMP Model

The results of the experiment were then exported to JMP for analysis. After some adjustments were made to the response table (viz., renaming field codes and defining sort criteria to enhance readability of the results,) the JMP model was created using the “Fit Model” platform.

Next, the “Profiler” platform in JMP was used to generate a matrix of response curves for each response-factor combination.

The last step in the analysis was to set, within JMP, the desired setting for each response. JMP created a set of desirability functions using those factors. Upon giving JMP the command to “maximize desirability,” a list of optimized factors was generated. The results were interesting, as will be shown.

D. SCOPE OF THIS THESIS

The scope of this research is primarily to examine a generalized system of PTSD health-care delivery. The generalized system is represented by the ExtendSim model, and ultimately in the JMP model, either of which can be manipulated to discover the outcomes of various factors.

It is important to emphasize that the models presented in this thesis are representations of reality made within the filter of a broad set of assumptions. It is acknowledged that these assumptions may be in need of fine-tuning, which should be the subject of future work. In the process, the model will require initial validation and subsequent validation at each iteration of major improvement.

E. BENEFITS OF THIS STUDY

Using the products of this research, the VA decision maker can discover the factors that have the greatest impact on PTSD health-care delivery, which will allow him to make improvements to the system in the most efficient manner, given the limited resources available. The end result is a more rapidly-improved system that provides better, more efficiently-delivered health care serving more patients with PTSD.

In addition, this systems engineering-based research will inform the VA decision maker of the data that is required to be collected for successful monitoring of the PTSD Health-care system. Knowing this, the VistA Information system can be replaced or modified to collect this data and present the resulting information in a more usable and readily-available form, thereby improving the function of system monitoring (and ultimately increasing the speed of system improvement).

Future work can be applied to enhancing the models to bring them to a higher degree of alignment with reality. This will cause the models to become more complex, but it will increase the ability of the decision maker to more finely tune the real-life system.

THIS PAGE INTENTIONALLY LEFT BLANK

II. SYSTEM DESCRIPTION

A. OVERVIEW

In the simplest of terms, the system of providing PTSD health care involves untreated patients entering the system and cured patients exiting the system. Along the way, health care providers are used as a resource. Figure 2 shows a very basic flowchart diagramming this system.

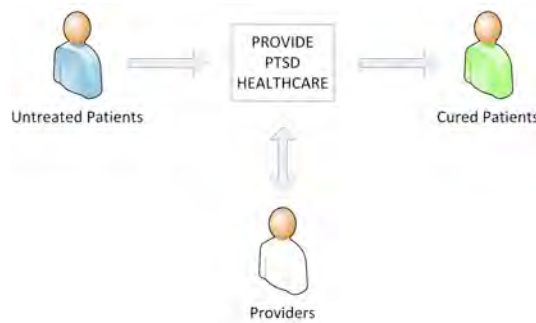

Figure 2. Basic flowchart for PTSD health-care delivery

Expanding upon the basic flowchart, the functional decomposition of *curing people* (Figure 1) is incorporated, resulting in Figure 3.

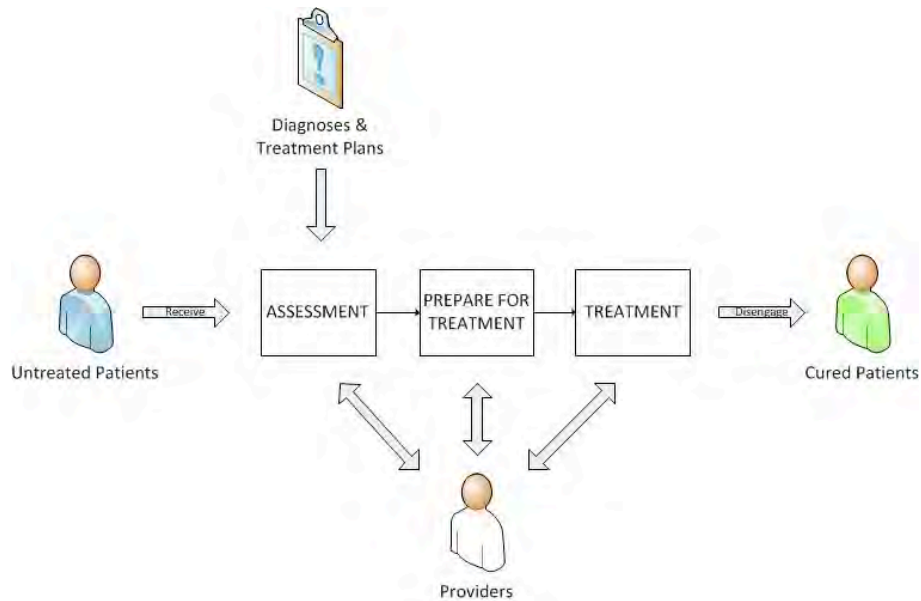

Figure 3. Expanded flowchart for PTSD health-care delivery

Note that providers are involved in all of the major sub-functions of *curing people*. This is the nature of PTSD health care. To further emphasize this point, functions were mapped to physical components of the system in Table 3. Note that all of the functions require a human health care provider or staff. Second to human health care provider in system intensity is the medical information system.

	Receive		Assess			Prepare		Treat				Disengage		Continuously Improve		
	Receive Referral	Schedule Assessment	Perform Assessment	Establish Diagnosis	Create Treatment Plan	Provide Scaffolding		Provide PE	Provide CPT	Provide Care Management	Provide Medication Management	Provide Follow-on Care	Discharge Case	Maintain Patient History	Measure Performance & Effectiveness	Adjust Process
Telephone Reception	X															
Reception Desk	X	X														
Medical Info System	X	X	X	X	X	X						X	X	X	X	
Human Provider/Staff	X	X	X	X	X	X		X	X	X	X	X	X	X	X	X
PTSD Website						X						X				X
PTSD Policy																X

Table 3. Mapping functions to physical components

As described in the introduction, the system of delivering PTSD healthcare involves two major functions: *curing people* and *continuously improving*. Supporting functions for curing people are: *receiving*, *assessing*, and *preparing the patient*, followed by *providing treatment* and *disengaging*. Under *continuously improve*, the functions are *maintain patient history*, *monitor performance and effectiveness*, and *adjust process*.

Figure 4 integrates the sub-functions of *cure people*, as they are shown in Figure 1 into a business process flowchart. The result is a cross-functional flowchart that provides a clear chronology of the major activities involved with *delivering PTSD health care* (Microsoft Visio Premium, 2010).

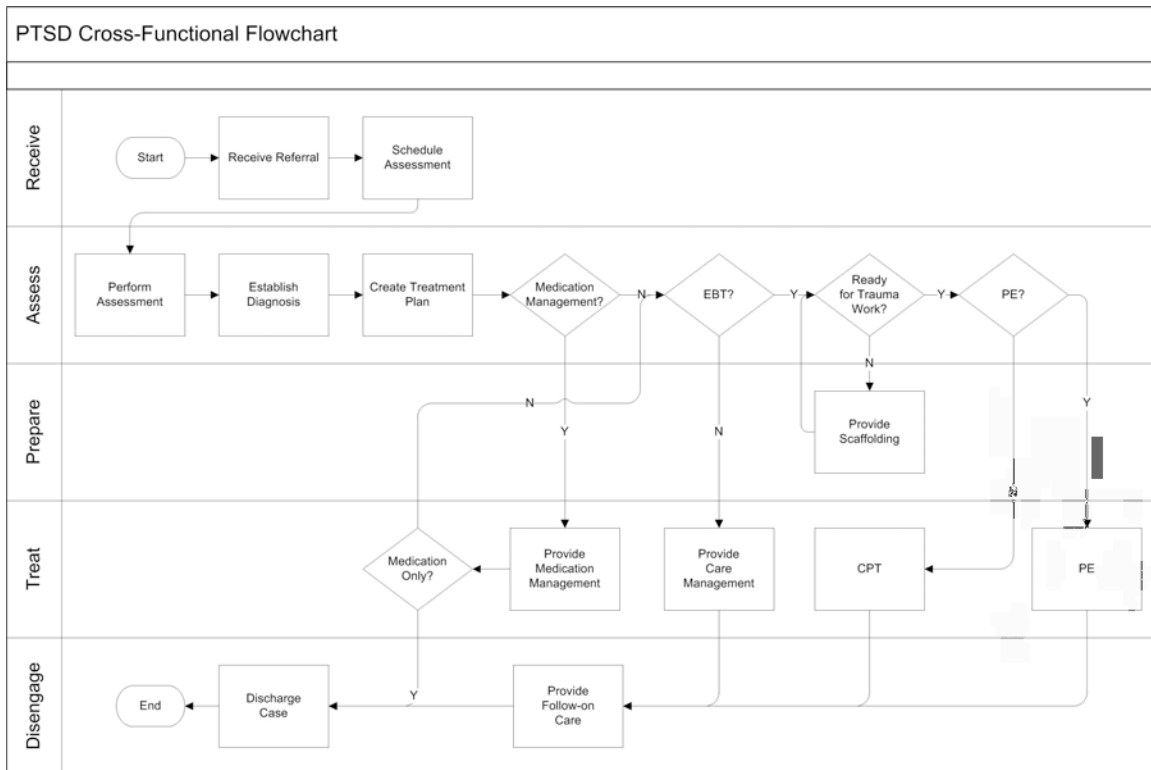

Figure 4. Cross-functional flowchart for the system of PTSD health-care delivery

B. RECEIVE PATIENT

Receiving a patient involves receiving a referral and scheduling an assessment.

1. Receive Referral

Referrals can come from a variety of sources. As PTSD screening has been integrated into the primary care setting, a majority of referrals come from this source. Other referral sources include self-referral, referrals from psychiatric care, referrals from law enforcement, etc.

2. Schedule Assessment

Scheduling an assessment is a relatively simple administrative function. It involves matching a new patient up with a provider for an in-depth assessment.

C. ASSESS PATIENT

1. Perform Assessment

Most patients are assessed over a single 90-minute one-on-one interview session with a provider. Some patients require more than one session to complete the assessment.

2. Establish Diagnosis

Providers establish the diagnosis of PTSD during and after the 90-minute assessment. The severity of the diagnosis is also established. The severity will influence the treatment plan prescription. If the patient is determined not to have PTSD, no further action will be taken.

3. Create Treatment Plan

The treatment plan is created once the diagnosis is set. This involves documenting the diagnosis in the medical information system. It may involve conferring with other qualified providers and/or transferring the patient to a different provider.

D. PREPARE PATIENT FOR TREATMENT

1. Scaffolding

Some patients are prescribed PE or CPT in their treatment plan. PE and CPT are Evidence-Based Therapies (EBT). EBT are intense therapies, designed for severe cases of PTSD. These therapies require a significant amount of commitment, readiness, and willingness from the patient. Accordingly, not all patients are immediately prepared for EBT. To prepare an EBT candidate for CPT or PE, a provider will meet with the patient

for an indeterminate number of encounters. This preparatory phase is referred to in this thesis as *scaffolding*. The term is not widely accepted, but generally it describes groundwork that is required before EBT can begin. It consists of an indeterminate number of sessions with a provider, focused on preparing the patient for the rigorous, intense therapy that is EBT.

If a patient is not prescribed EBT in their treatment plan, they generally do not require scaffolding.

E. PROVIDE TREATMENT

All therapies are intended for delivery over a multiple number of encounters, with one encounter being delivered each week (except medication management, which is delivered every 13 weeks). The actual frequency of the treatment will vary, depending on the availability of a provider, the availability of group members, and whether the patient cancels the encounter appointment. Therefore, the frequency indicated for the prescribed treatment is to be viewed as a maximum frequency.

Some therapies are delivered in groups (i.e., more than one patient per provider,) and some treatment plans require more than one provider. Group size and provider intensity and their incorporation into the model will be discussed later.

1. Prolonged Exposure

PE includes psychoeducation, breathing retraining, exposure to situations that the patient has related to the trauma, and the recalling/recounting of traumatic events. It is a 12-session program, and is always conducted on an individual basis (group size = 1). Patient-provider encounters are meant to be 90 minutes each.

2. Cognitive Processing Therapy

Cognitive Processing Therapy is designed to address non-fear-related emotions, the context of the meaning elements of the traumatic memory, and examine the level of

accommodation that has been made for the traumatic memory. The structure of CPT is similar to that of PE, except that CPT may be provided in a group setting. Group size for CPT is a design factor for the system.

3. Care Management

Non-EBT therapy is referred to as care management. This is more general psychotherapy, focused on the PTSD symptoms of the patient. It is defined by both the number of appointments and the group size. Both are design factors for the system and can vary widely among patients.

4. Medication Management

All PTSD patients are offered medication if their assessment indicates it. Half of these patients will accept the medication. Of those who accept, about half will require traditional (i.e., PE, CPT, or care management) in addition to medication management.

F. DISENGAGE

Most PTSD patients will live with some level of their disorder for the rest of their lives. For this model, however, all patients are assumed to have a finite treatment plan, as described in this document. Further study will be required to determine more realistic categories for the methods of disengagement from (or continuance in) the PTSD health-care system.

G. CONTINUOUSLY IMPROVE

1. Maintain Patient History

The medical information system in this case is VistA. VistA is a legacy system that has been evolving over the past few decades. It needs considerable improvement or replacement to adequately serve the function of delivering PTSD health care.

2. Monitor Performance and Effectiveness

A robust medical information system that is tailored to deliver the required measures of performance and effectiveness is a necessary component to sustain continuous improvements to the overall system.

3. Adjust Process

Adjusting the process involves changing PTSD policy, based on revised optimization resulting from a refined model. Improvements made in this manner will improve the quality, efficiency, and timeliness of the PTSD health-care system.

THIS PAGE INTENTIONALLY LEFT BLANK

III. OPERATIONAL MODEL

A. MODEL DEVELOPMENT AND IMPLEMENTATION

As previously noted, the main simulation platform for the model was originally ExtendSim, Version 7, but was upgraded to Version 8 to capitalize on new features that were important to the research. The description of model development and implementation below concerns the use of Version 8. Screen shots of the final version of the ExtendSim model are provided in Appendix A: ExtendSim Screen Shots. Next, we describe the parameters of the PTSD health-care delivery system as they are used in the model. We will also highlight the factors and responses.

1. Providers

a. Work Schedule

Each provider works 40 hours per week (Monday through Friday), and receives five weeks of vacation per year. Within each workday, a provider works eight hours, but three of those hours are consumed with meetings and chart work (patient tracking). This leaves five hours per workday available for patient contact.

b. Provider Quantity

To determine the effect that the number of available providers has on the system, the *provider quantity* is made to be a design factor of the experiment. The levels for this factor are two, three, and four providers.

c. Utilization

Provider utilization is a measure of efficiency for the system. ExtendSim provides automatic calculation of resource utilization. Two variations of utilization are considered for this research. One considers patient cancellations as utilized time, the other considers patient cancellations as unutilized (lost) time. This technique will help

the user of the model to determine the scheduling requirements needed to obtain a desired *provider utilization* given an expected patient cancellation rate.

2. Patients

a. *Rate of Arrival*

Patients are assumed to arrive at a rate that is determined by an exponential distribution, with a mean of one patient every four calendar days. While this parameter is adjustable within the ExtendSim model, it is not a design factor of the experiment.

b. *Rate of Drop*

Patients will discontinue treatment for a variety of reasons. The overarching desire is that all patients adhere to their prescribed treatment plans, but it is expected that, regardless of the effort made to retain patients, a certain drop rate will exist. As the objective is to provide the best care possible to as many patients as possible, and given that there exists a finite amount of resources available with which to accomplish this, it would be good to know how patient drop rate affects the system.

To determine its effect on the system, *patient drop rate* is made to be a probabilistic design factor for the experiment. There are two levels for this design factor: *base case* and *less drops*. Each level is an empirical distribution representing the probability of a patient dropping after a traditional therapy session. The levels are defined in Table 4.

	After Each Traditional Therapy Session, the Probability a Patient Will:	
	Drop	Adhere
Base Case	0.02	0.98
Less Drops	0.01	0.99

Table 4. Definition of probabilistic design levels for patient drop rate

Future work would investigate the characteristics of the *patient drop rate* to develop a more precise modeling of this activity. Discovering categories of drop reasons and linking these categories to events within the model would help significantly to discover the optimal application of resources toward the reduction of the overall drop rate.

3. Assessments

Within the ExtendSim model, a patient is assessed as soon as a provider resource is available. Note, in its current state, this model only considers one resource: the PTSD health care provider. In addition, all providers are assumed to be equally qualified and equally appropriate to every task. Therefore, staff time required for handling the referral and scheduling the assessment are not considered in the model.

Assessments are approximately 90 minutes each, and require a single provider resource to complete. The model introduces randomness to the assessment session duration by incorporating a triangular distribution with a minimum of 80, a maximum of 100, and a mean of 90 minutes.

Future work may include developing multiple human resource categories (e.g., staff, multiple levels of qualification within the provider ranks, etc.). While ExtendSim version 8 provides a new feature named *Advanced Resource Management (ARM)* that will prove to be a valuable tool for this effort, it is not used in this thesis.

4. Establishing Diagnoses

In this model, all referrals are assumed to have PTSD in some form that will require treatment using one or more of the four treatment plans: medication management, care management, PE, or CPT.

Future work may include a bogus referral rate, if that is appropriate to the model.

5. Distribution of Treatment Plan Types

a. General

The current distribution of treatment plans among the patient population is assumed to be known. In broad terms, there are three treatment paths: a patient can be treated with traditional therapy (viz., care management, PE, or CPT); a patient can be treated with medication management alone; or a patient can be treated using both approaches. For the model in its current state, the following distribution is applied. This distribution is adjustable, but it is not a design factor for the experiment:

- 50% will require traditional therapy only
- 25% will require medication management only
- 25% will require a combination of the two

b. Traditional Therapy

Within traditional therapy, there are two possible treatment paths: EBT or care management. As previously stated, EBT is intensive therapy for severe cases of PTSD, while care management is reserved for milder cases. For the model in its current state, the following distribution is applied. This distribution is adjustable, but it is not a design factor for the experiment:

- 27% will require EBT
- 73% will require care management

c. EBT

Within EBT, there are two possible treatment paths: PE or CPT. For the model in its current state, the following distribution is applied. This distribution is adjustable, but it is not a design factor for the experiment:

- 50% will require PE
- 50% will require CPT

6. Scaffolding

When prescribing EBT, the model currently assumes that some quantity of scaffolding sessions will be required, as previously described. To determine the effect that quantity of scaffolding sessions has on the system. It is included as a design factor of the experiment. In setting this parameter as a design factor, the assumption is made that there is a certain amount of control over the average number of scaffolding sessions that are provided to the patient population that is prescribed EBT. The levels for this design factor are three, six, or nine sessions.

Scaffolding sessions are approximately 60 minutes each, and require a single provider resource to complete. The model introduces randomness to the scaffolding session duration by incorporating a triangular distribution with a minimum of 50, a maximum of 70, and a mean of 60 minutes.

7. Provider Intensity

Provider intensity is defined as the number of providers required, on average, for a given traditional therapy session. Currently, a majority of traditional therapy is provided by more than one provider. To determine its effect on the system, provider intensity is made to be a probabilistic design factor for the experiment. There are three levels for this design factor: base case; less intensity; and least intensity. Each case is a different distribution of the number of providers required for a traditional therapy session. The probabilistic design levels for provider intensity are defined in Table 5.

	% of Traditional Therapy Sessions Requiring:	
	1 Provider	2 Providers
Base Case	25	75
Less Intensity	50	50
Least Intensity	75	25

Table 5. Definition of probabilistic design levels for provider intensity

8. Structure of Therapies

a. PE

PE is set in the model as consisting of 12 weekly sessions in a nongroup (single patient) setting. Session duration and variability are identical to those for assessments.

b. CPT

CPT is set in the model as consisting of 12 weekly sessions in either a group or single patient setting. To determine the effect of *CPT group size* on the system, it is made to be a design factor of the experiment. The levels for this factor are groups of one, five, and nine patients per group. Session duration and variability for CPT sessions are identical to those for assessments.

c. Care Management

Care management is the most common of the traditional therapies in use. It consists of 4 weekly sessions in either a group or single patient setting. To determine the effect of *care management group size* on the system, it is made to be a design factor of the experiment. The levels for this factor are groups of one, five, and nine patients per group. Session duration and variability for care management sessions are identical to those for assessments.

d. Medication Management

Medication management consists of quarterly visits with a provider in a single patient/single provider setting, with each session lasting approximately 30 minutes. The model introduces randomness to the medication management session duration by incorporating a triangular distribution with a minimum of 20, a maximum of 40, and a mean of 30 minutes.

If a patient is undergoing traditional therapy concurrent with medication management, it is assumed that the quarterly medication appointments will occur within a traditional therapy session for as long as the traditional therapy plan continues. When the traditional therapy is concluded, separate medication management appointments are scheduled.

In reality, patients continue medication management for varying lengths of time. For the model in its current state, all patients are assumed to continue medication management for five years. At the end of five years, the patient is disengaged.

Future work would investigate the characteristics of the medication management program to develop a more precise modeling of this activity. This would require modifications to the VistA medical information system, as it is not currently set up to track this information.

9. Patient-Provider Encounters

Patient-provider encounters are subject to variability completion rate due to variability in rates of patient cancellation and encounter failure.

a. Patient Cancellation

Patients will cancel their scheduled appointment at a known rate. There are two basic types of patient cancellations: those that are made sufficiently in advance of the scheduled appointment such that the provider may be rescheduled; and those that are not. The former are not considered in this model, because they do not affect provider utilization. The latter are important to the system.

To determine its effect on the system, *patient cancellation rate* is made to be a probabilistic design factor for the experiment. There are two levels for this design factor: *base case* and *less cancellation*. Each level is an empirical distribution representing the probability of a patient cancelling prior to a traditional therapy session (with insufficient time to reschedule the provider). The probabilistic design levels for patient cancellation rate are defined in Table 6.

	Prior to Each Traditional Therapy Session, the Probability a Patient Will:	
	Cancel	Attend
Base Case	0.18	0.82
Less Cancellation	0.09	0.91

Table 6. Definition of probabilistic design levels for patient cancellation rate

Future work would investigate the characteristics of the *patient cancellation rate* to develop a more precise modeling of this activity. Discovering categories of cancellation reasons and linking these categories to events within the model would help significantly to discover the optimal application of resources toward the reduction of the overall cancellation rate.

b. Encounter Failure

Not all patient-provider encounters will be successful. Assuming there is an established structure to traditional therapy that must be completed in a sequential manner (i.e., completing the current phase is a prerequisite to proceeding to the next phase, etc.), then failing to meet the requirements of the scheduled encounter will result in the need to repeat that session.

To determine its effect on the system, *encounter failure rate* is made to be a probabilistic design factor for the experiment. There are three levels for this design factor: *base case*; *less failure*; and *least failure*. Each level is an empirical distribution representing the probability of the failure of a traditional therapy session. The probabilistic design levels for encounter failure rate are defined in Table 7.

	Probability that a Traditional Therapy Session Will:	
	Fail	Succeed
Base Case	0.30	0.70
Less Failure	0.20	0.80
Least Failure	0.10	0.90

Table 7. Definition of probabilistic design levels for encounter failure rate

Future work would investigate the characteristics of the *encounter failure rate* to develop a more precise modeling of this phenomenon. Discovering categories of reasons for failure and linking these categories to events within the model would help significantly to discover the optimal application of resources toward the reduction of the overall failure rate.

B. SUMMARY OF FACTORS, RESPONSES, AND EXPERIMENTAL DESIGN

1. Factors

Experiment factors are summarized in Table 8. Note that a full-factorial experiment design includes $(3^6)(2^2) = 2916$ scenarios. With three trials per scenario, there are 8748 separate trials. This would not have been practicable without the Scenario Manager feature of ExtendSim 8.

#	Factor	Level 1	Level 2	Level 3
1	Provider Count	2	3	4
2	Provider Intensity	Base	Less	Least
3	CPT Group Size	1	5	9
4	CM Group Size	1	5	9
5	Scaffolding Session Count	3	6	9
6	Cancellation Rate	Base	Less	--
7	Failure Rate	Base	Less	Least
8	Drop Rate	Base	Less	--

Table 8. Summary of experiment factors

2. Responses

Experiment responses are summarized in Table 9.

Attribute	Measured Response	Definition
Efficient	Provider Utilization	% of available provider time engaged in PTSD work
Capacity	Throughput	Quantity of patients completed over time
Timely	Treatment Duration	Average duration of traditional treatment plan
Timely	Time Between Encounters	Average time between traditional therapy encounters

Table 9. Summary of experiment responses

C. RESULTS

The resulting ExtendSim model was programmed to simulate 260 weeks (approximately five years) of system operation. The amount of time allowed for the system to reach equilibrium averaged 26 weeks (approximately 10% of the simulation time). The experiment executed automatically and was completed in approximately four hours. The results were automatically recorded to a table within scenario manager. Scenario manager then exported the table to JMP for analysis.

IV. ANALYSIS

A. JMP MODEL

Given that a full-factorial experiment was conducted on using the ExtendSim model, JMP was able to generate a *least squares fit* that well predicts the combined effects of the model factors. For parameter estimates and prediction plots of the JMP model, please see Appendix B: JMP Model Fit Statistics.

B. PREDICTION PROFILER

The prediction profiler (Figure 5) displays response curves for each factor. A response curve is the predicted response as one variable is changed while the others are held constant at the current values. The profiler recalculates the predicted responses (in real time) as the value of a factor is varied. In this manner, the profiler is a way of testing the system responses due to changing one factor at a time.

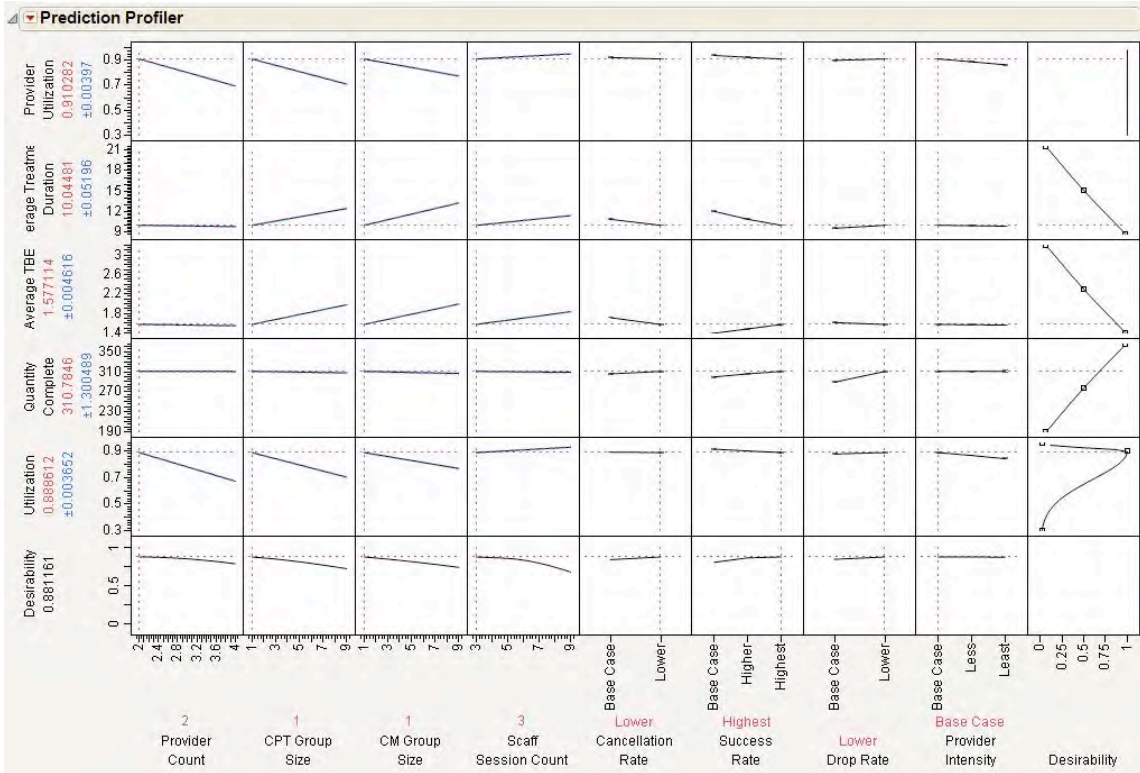

Figure 5. JMP prediction profiler (including maximized desirability functions)

1. Interpreting Factors and Responses

The vertical dotted line for each factor shows its current value or setting. If the factor is nominal, the X-axis identifies categories. For each factor, the value above the name is its current value. In JMP, the current value can be changed by clicking in the graph or by dragging the dotted line to a new value. As shown, all the factors are in the optimal factors to maximize desirability, which will be discussed later.

The horizontal dotted lines show the current predicted values for each response given the current values of the factors. The current predicted value is shown to the right (underneath) the response name. The 95% confidence interval on the mean response is shown underneath the current predicted value.

2. Interpreting System Sensitivities

Within each graph of the prediction profiler, the slope of the response curve is an indication of the sensitivity of the system to that factor. The user should leverage this fact to aid in the decision-making process for system adjustments. The assumption is that implementing changes in factors requires time and human/financial resources, and that time and resources are limited. It follows that the most efficient use of these limited resources would be to apply them toward changing the more influential factors first.

C. DESIRABILITY FUNCTIONS (OPTIMIZATION)

Within the JMP prediction profiler platform resides an option to set and manipulate system *desirabilities*. A desirability graph is displayed for each response in Figure 5. For each response, JMP knows the range of values that occur. When setting a desirability, JMP will display a high, middle, and low value for the response. If, for example, the average treatment duration were desired to be minimized, JMP would recommend a 0.9819 desirability for a value of 8.75 weeks (the lowest value in the experiment for average TBE). JMP would then recommend a 0.5 desirability for 15.125 weeks (the middle value for that response), and a 0.066 desirability for 21.5 weeks (the highest value).

In this manner, the desirability of each response was programmed. The desirabilities are summarized in Table 10. For high, middle, and low, values are on the left and the desirability for that value is indicated on the right. Note that the goal is to maximize timeliness and capacity, while the specific goal of 90% provider utilization is desired.

Attribute	Measured Response	High Value & Desirability		Middle Value & Desirability		Low Value & Desirability	
Efficient	Provider Utilization	0.96	0.0183	0.9	1.0	0.3	0.0183
Capacity	Throughput	365	0.9819	277.5	0.5	190	0.066
Timely	Treatment Duration	21.5	0.066	15.125	0.5	8.75	0.9819
Timely	Time Between Encounters	3.2	0.066	2.3	0.5	1.4	0.9819

Table 10. Desirability table for system responses

D. FACTORS OPTIMIZED FOR MAXIMUM DESIRABILITY

1. Optimized Factor Settings

Once all desirability values were programmed and the profiler was instructed to maximize overall system desirability, the prediction profiler recalculated the response curves and displayed the optimized results, as seen in Figure 5. Note the overall system desirability of 88.1%. The optimized factors can also be seen in Figure 5, but they are summarized (displayed unshaded) in Table 11.

#	Factor	Level 1	Level 2	Level 3
1	Provider Count	2	3	4
2	Provider Intensity	Base	Less	Least
3	CPT Group Size	1	5	9
4	CM Group Size	1	5	9
5	Scaffolding Session Count	3	6	9
6	Cancellation Rate	Base	Less	--
7	Failure Rate	Base	Less	Least
8	Drop Rate	Base	Less	--

Table 11. Optimal factors, as determined by JMP to maximize desirability functions

2. Actual vs. Expected Results

a. Provider Count

A provider count of two was expected, as this is the number of providers that are currently available to handle the current patient load. Rough estimates for provider utilization for the test site (Monterey CBOC) in the base case (prior to model development) were 60%. Therefore, it would not be logical to add more providers when the desired efficiency level (provider utilization) is 90%.

b. Provider Intensity

The optimal factor setting of base case was surprising. Recall that the base case for provider intensity was the most provider intense setting. Further investigation is required, but it is hypothesized that, since reducing provider count to a setting lower than two was not an option, provider intensity was able to stay high. A higher provider-patient ratio would seem to indicate higher system quality, so this setting is not undesirable.

c. CPT and CM Group Sizes

Group sizes of one for these factors were surprising. It was expected that higher group sizes would lead to higher throughput, and that optimal factors for these factors would be close to nine. Further investigation is required, but it is hypothesized that with large groups comes high administrative overhead. For example, if a patient drops from a group, another patient must replace him. That person may not be at the same level as his predecessor, which would delay the group's recovery.

d. Scaffolding Session Count

Scaffolding session count at a low optimal setting was expected. Every extra session is noted as a cost to the system.

e. Cancellation, Failure, and Drop Rates

Results for these rates were also expected. The decision maker must decide whether the cost in time, human resources, and funding are worth the improvement in system performance.

3. Optimal Responses (Maximized Desirability)

The optimal responses (or maximized desirability) can also be seen in Figure 5, but they are summarized in Table 12.

Attribute	Measured Response	Result	Units
Efficient	Provider Utilization	0.88	--
Capacity	Throughput	310	Patients
Timely	Treatment Duration	10.0	Weeks
Timely	Time Between Encounters	1.58	Weeks

Table 12. Simulation responses resulting from optimal factors

4. System Improvements Gained Over Base Case

To demonstrate the improvements that are available to the system, a comparison was made between the optimal and base factors. Using the JMP model, the base factors were entered into the prediction profiler. The base factors, along with the optimized factors, are summarized in Table 13.

#	Factor	Base	Optim
1	Provider Count	2	2
2	Provider Intensity	Base	Base
3	CPT Group Size	9	1
4	CM Group Size	9	1
5	Scaffolding Session Count	4	3
6	Cancellation Rate	Base	Less
7	Failure Rate	Base	Least
8	Drop Rate	Base	Less

Table 13. Comparison of base and optimal factors

With the base factors set, the system responses were noted, and summarized in Table 14. Note that considerable improvements can be obtained. In fact, all attributes of the system are improved, and overall system desirability can be improved by 80% over the base case.

Attribute	Measured Response	Base	Optim	Delta	% Improve
Efficient	Provider Utilization	0.61	0.88	0.27	44%
Capacity	Throughput (patients)	270	310	40	15%
Timely	Treatment Duration (weeks)	17.6	10.0	-7.6	43%
Timely	Time Between Encounters (weeks)	2.30	1.58	-0.72	31%
Overall System Desirability		0.49	0.88	0.39	80%

Table 14. System improvements gained using optimized factors over base case

THIS PAGE INTENTIONALLY LEFT BLANK

V. CONCLUSIONS AND RECOMMENDATIONS

A. SECONDARY RESEARCH QUESTIONS

Recall that, to answer the primary research question, the definitions of *efficiency*, *capacity*, and *quality* needed to be determined.

1. Definition of *Efficiency* in PTSD Health-Care Delivery

As the system analysis has shown, PTSD health-care delivery is a human resource-intensive endeavor. Therefore, *efficiency* in the system implies *efficiency* in the use of providers. Accordingly, the definition of *efficiency* in PTSD health-care delivery is *high provider utilization*.

2. Definition of *Capacity* in PTSD Health-Care Delivery

Defining *capacity* of the system was intuitively accomplished. The system should treat as many patients as possible. Therefore, *patient throughput* was measured to assess *capacity*.

3. Definition of *Quality* in PTSD Health-Care Delivery

Quality is a patient determination. For this research, a patient is assumed to want to become as healthy as possible as soon as possible. The latter refers to the *timeliness* of the system. Therefore, *average treatment duration* and *average time-between-encounters* were measured to determine *timeliness*, and therefore *quality*. In future work, *treatment efficacy* will be incorporated into the model. In doing so, a full measure of quality will be obtained.

B. PRIMARY RESEARCH QUESTION

Recall that the research question was, “For the system of PTSD Health-care delivery, what are optimal factors that will maximize *efficiency*, *capacity*, and *quality*?” Assuming the models are valid, the factors in Table 15 should be attempted at the

Monterey CBOC. In real terms, this would involve dissolving group therapy, lowering the average scaffolding session count, implementing training and policies that would cut the cancellation and drop rates by half, and influencing the success rate of therapy sessions to reduce their failure rate to 10%.

#	Factor	Optim
1	Provider Count	2
2	Provider Intensity	75% 2:1 25% 1:1
3	CPT Group Size	1
4	CM Group Size	1
5	Scaffolding Session Count	3
6	Cancellation Rate	9%
7	Failure Rate	10%
8	Drop Rate	1%

Table 15. Optimized factors

If successful in achieving these factors, the Monterey CBOC would realize a 44% increase in *efficiency* (provider utilization), a 15% increase in *capacity* (patient throughput), and approximately a 37% increase in *quality* (timeliness, measured in treatment duration and time-between-encounters). Overall, the system will achieve an 80% increase in desirability.

C. OBJECTIVE ACHIEVEMENT

Recall that the objective was *to provide the best care in the most efficient manner possible to as many affected veterans as possible*. The use of the words “best,” “most,” and “to as many as possible” categorize this objective as arguably unachievable. The mere act of pursuing the objective, however, will result in improvements in the areas of quality, efficiency, and capacity. Toward that end, it has been shown that improvements

can be made in these areas, assuming the model is valid. It is fair to say, therefore, that this research is a positive step toward achievement of that objective, as discussed above.

D. SUMMARY OF RECOMMENDATIONS FOR FUTURE WORK

As the objective is a constantly moving target, there will continue to be work in this field. Given the grave human aspect of the problem, it should continue to benefit from continued and abundant support. Suggestions for future work have been mentioned throughout this thesis. They are summarized here.

1. Validate the Models

Conduct an initial validation of the models and repeat validations at each iteration of major improvement.

2. Improve the Measurement of *Quality*

Incorporate efficacy for the various treatment paths into the model. Compare the entrance and exit PTSD scores from standardized psychological tests and incorporate the efficacy of treatment plans into the models.

3. Improve the Modeling of Human Resources

Develop multiple human resource categories (e.g., staff, multiple levels of qualification within the provider ranks). Leverage the ARM feature of ExtendSim 8, which will prove to be a valuable tool for this effort.

4. Improve the Alignment of the Models with Reality

Enhance the models to bring them to a higher degree of alignment with reality. This will cause the models to become more complex, but it will increase the ability of the decision maker to more finely tune the real-life system.

For the probabilistic design factors, a more detailed analysis of the historical data should be conducted. This may uncover smoother distributions that may result in an improved representation of reality within the models.

To account for patient referrals that are discovered to be in error (i.e., after assessment, the patient is discovered to not have PTSD), incorporate a bogus referral rate into the model.

Investigate the characteristics of the medication management program to develop a more precise modeling of this activity. This would require modifications to the VistA medical information system, as it is not currently set up to track this information.

Investigate the characteristics of the *patient drop rate*, *patient cancellation rate*, and *encounter failure rate* to develop a more precise modeling of these activities. Discovering categories for these rates, and linking them to events within the model would help significantly to discover the optimal application of resources toward their reduction.

5. Improve VA Data Tracking and Presentation

Gathering system statistics were a challenge for this project. The VA information system technician worked long hours to gather information that should (in a system designed to *continuously improve*) be readily available. We contend that future work must include a redesign of the VA medical information system.

APPENDIX A: EXTENDSIM SCREEN SHOTS

Figure 6 through Figure 11 display screen captures of the ExtendSim model. They are inserted here to provide a visual sense of the complexity of the ExtendSim model.

Figure 6 displays a view of the entire model, including the control section. Areas of the model have been blocked off and labeled to generally show what sub-functions are being supported.

The rest of the screen shots are exploded views of various sections of the model. Figure 7 shows the control section of the model, including the executive block (clock icon that controls the discrete time activity of the model), provider count and resource blocks, provider utilization calculators, provider shift schedules, and the scenario manager block. Figure 8 shows the receive, assess, and prepare activities as they are represented in model. Figure 9 shows how traditional therapy is represented in the model, along with the tracking activities as they support the *continuously improve* function. Figure 10 shows how medication management is represented in the model. Figure 11 shows an exploded view of the scaffolding block, which supports the *prepare patient* function.

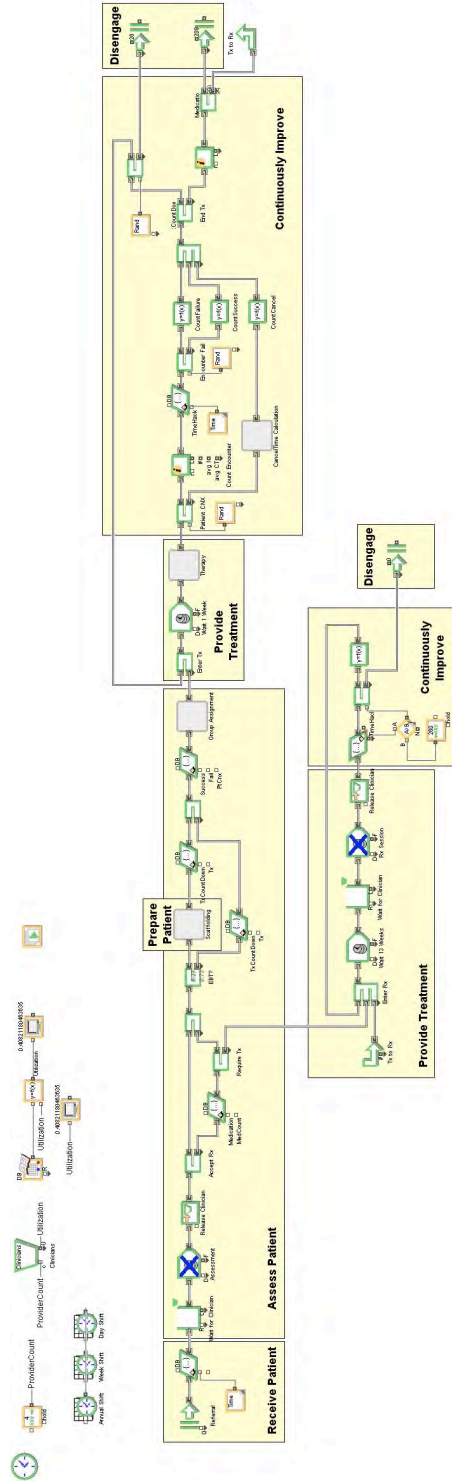

Figure 6. Extend Sim Model of PTSD System (Entire View)

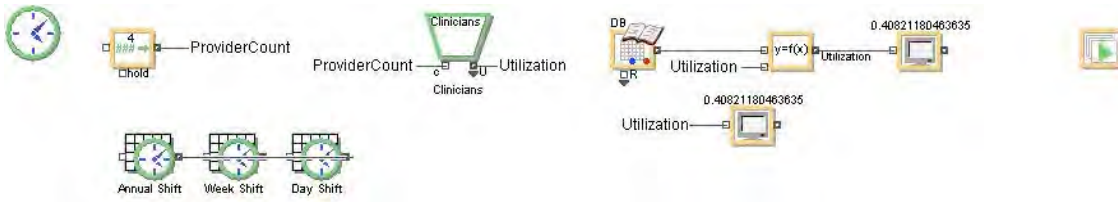

Figure 7. Control section of ExtendSim model

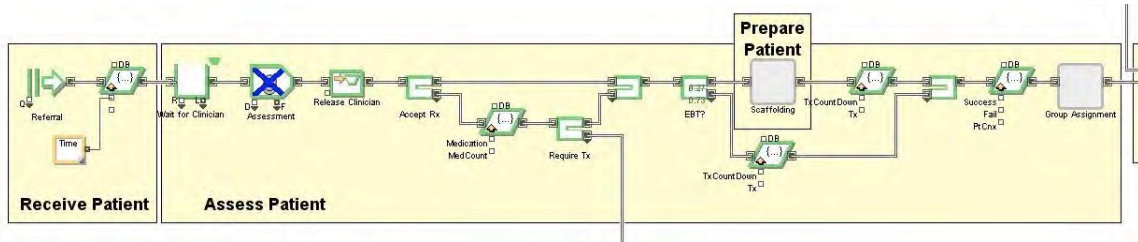

Figure 8. Receive, assess, and prepare functions represented in ExtendSim model

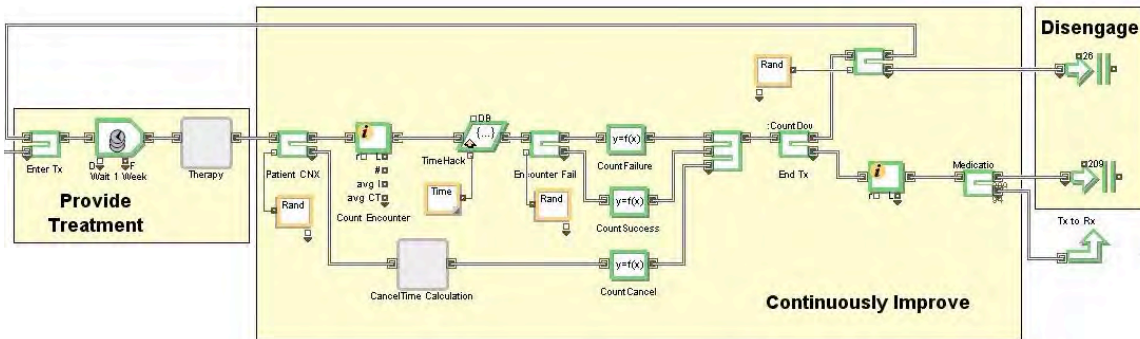

Figure 9. Traditional therapy represented in ExtendSim model

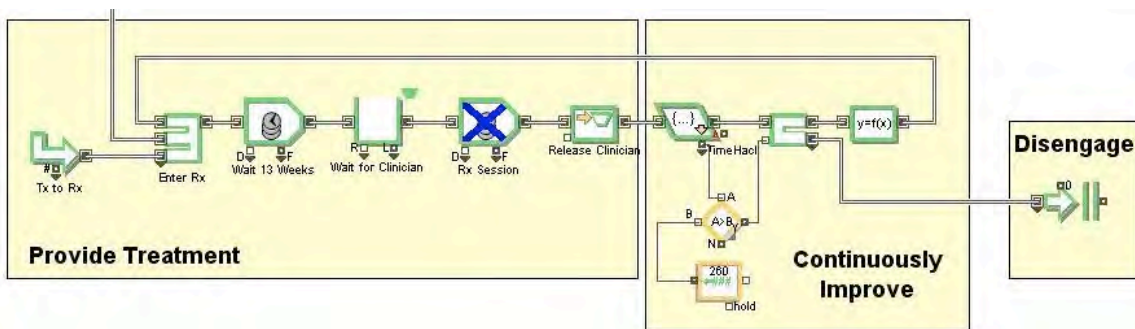

Figure 10. Medication management represented in ExtendSim model

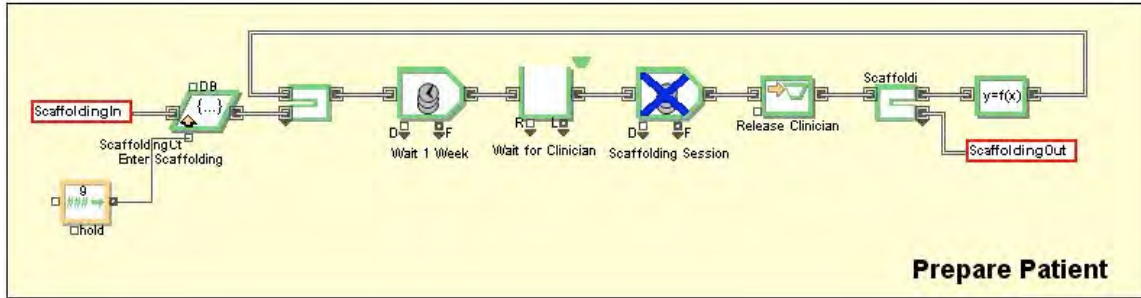

Figure 11. Detail of “Prepare Patient” block seen in Figure 6.

APPENDIX B: JMP MODEL FIT STATISTICS

Table 16 shows that most factors correlate with the responses (i.e., probability < 0.0001 of t ratio assuming null hypothesis is true). Figure 12, Figure 13, Figure 14, and Figure 15 show, for each response, plots of how well the JMP model was able to predict results from the ExtendSim simulation. Actual ExtendSim simulation results are shown as gray dots. The JMP prediction is indicated by a solid line.

It can be seen at a glance that this model fits well. The horizontal dashed line (sample mean of the response) falls well outside the bounds of the 95% confidence curves (dotted lines surrounding solid line of JMP prediction), indicating the model is significant. The response p-values (all are below 0.0001), R^2 , and root mean square error (RMSE) appear below the plot. The RMSE is an estimate of the standard deviation of the system noise, assuming that the unestimated effects are negligible. Note that quantity complete has a large deviation, but all other responses are tightly correlated.

Resp.	Factor	Estimate	Std Error	t Ratio	Prob> t
Average Treatment Duration	Intercept	9.950346294	0.036895858	269.6873549	<0.0001
	Provider Count	-0.094277881	0.009003901	-10.47078162	<0.0001
	CPT Group Size	0.306138024	0.002250975	136.0023953	<0.0001
	CM Group Size	0.406729255	0.002250975	180.6902395	<0.0001
	Scaffolding Session Count	0.236315734	0.0030013	78.73778314	<0.0001
	Cancellation Rate[Base Case]	0.438287439	0.007351654	59.61752523	<0.0001
	Success Rate[Base Case]	1.064221542	0.010396809	102.3603985	<0.0001
	Success Rate[Higher]	-0.088334096	0.010396809	-8.496269729	<0.0001
	Drop Rate[Base Case]	-0.215088685	0.007351654	-29.25718144	<0.0001
	Provider Intensity[Base Case]	0.06029373	0.010396809	5.799253241	<0.0001
	Provider Intensity[Less]	0.007048107	0.010396809	0.677910581	0.4978
Average Time-Between-Encounters	Intercept	1.359936608	0.003277707	414.9048826	<0.0001
	Provider Count	-0.013079944	0.000799877	-16.35244437	<0.0001
	CPT Group Size	0.050686367	0.000199969	253.4708038	<0.0001
	CM Group Size	0.052350811	0.000199969	261.7943017	<0.0001
	Scaffolding Session Count	0.04371071	0.000266626	163.9403647	<0.0001
	Cancellation Rate[Base Case]	0.0695809	0.000653097	106.5399419	<0.0001
	Success Rate[Base Case]	-0.090431302	0.000923618	-97.90980756	<0.0001
	Success Rate[Higher]	-0.001017726	0.000923618	-1.101890448	0.2705
	Drop Rate[Base Case]	0.018911024	0.000653097	28.95592558	<0.0001
	Provider Intensity[Base Case]	0.006211004	0.000923618	6.724642786	<0.0001
	Provider Intensity[Less]	0.000383983	0.000923618	0.415737295	0.6776
Quantity Complete	Intercept	294.3844307	0.923462545	318.7832925	<0.0001
	Provider Count	-0.101508916	0.225357691	-0.450434667	0.6524
	CPT Group Size	-0.344007202	0.056339423	-6.105976695	<0.0001
	CM Group Size	-0.51093107	0.056339423	-9.068802022	<0.0001
	Scaffolding Session Count	-0.307613169	0.07511923	-4.09499895	<0.0001
	Cancellation Rate[Base Case]	-2.469364426	0.184003784	-13.42018286	<0.0001
	Success Rate[Base Case]	-5.796296296	0.260220647	-22.27454421	<0.0001
	Success Rate[Higher]	0.500342936	0.260220647	1.92276417	0.0545
	Drop Rate[Base Case]	-10.8001829	0.184003784	-58.69543916	<0.0001
	Provider Intensity[Base Case]	-0.184499314	0.260220647	-0.709011051	0.4783
	Provider Intensity[Less]	-0.067901235	0.260220647	-0.260937153	0.7941
Utilization	Intercept	1.108718915	0.002592897	427.5984694	<0.0001
	Provider Count	-0.107813982	0.000632759	-170.387085	<0.0001
	CPT Group Size	-0.02316515	0.00015819	-146.4389772	<0.0001
	CM Group Size	-0.014993697	0.00015819	-94.78296992	<0.0001
	Scaffolding Session Count	0.006826463	0.00021092	32.36522229	<0.0001
	Cancellation Rate[Base Case]	0.002007637	0.000516646	3.885907071	0.0001
	Success Rate[Base Case]	0.013122735	0.000730647	17.96042422	<0.0001
	Success Rate[Higher]	-0.000292078	0.000730647	-0.39975255	0.6893
	Drop Rate[Base Case]	-0.005241223	0.000516646	-10.14471496	<0.0001
	Provider Intensity[Base Case]	0.022798066	0.000730647	31.20256031	<0.0001
	Provider Intensity[Less]	0.00071393	0.000730647	0.977119784	0.3285

Table 16. JMP model fit statistics

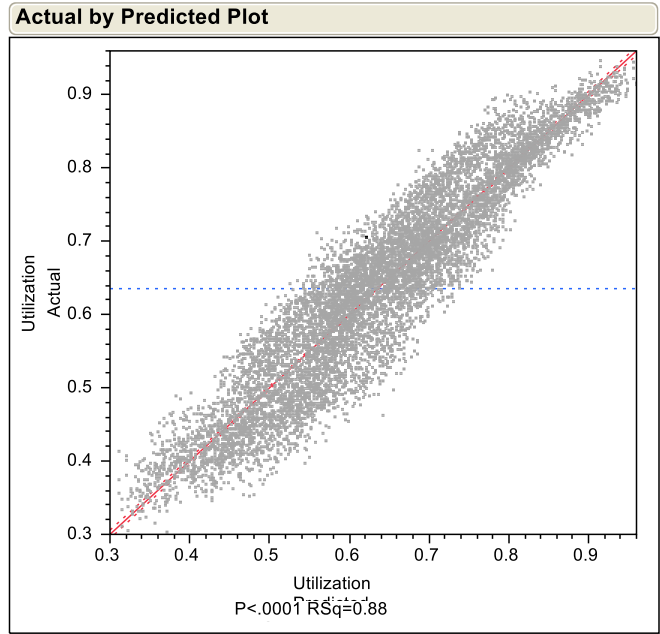

Figure 12. Actual provider utilization responses predicted by JMP model

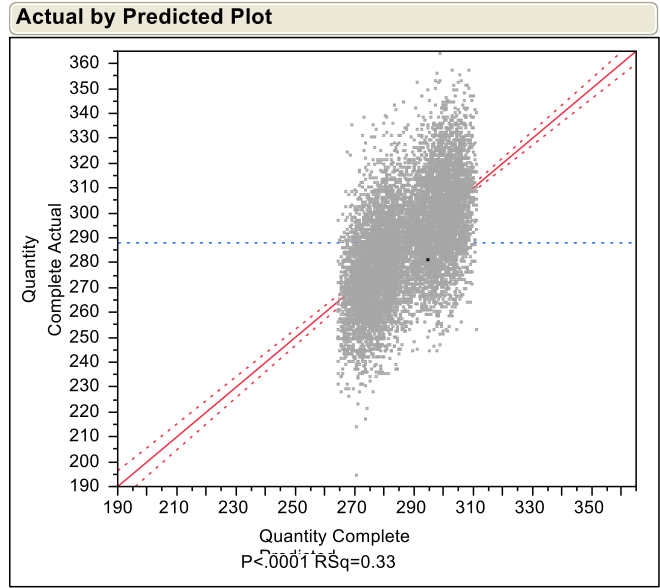

Figure 13. Actual quantity complete responses predicted by JMP model

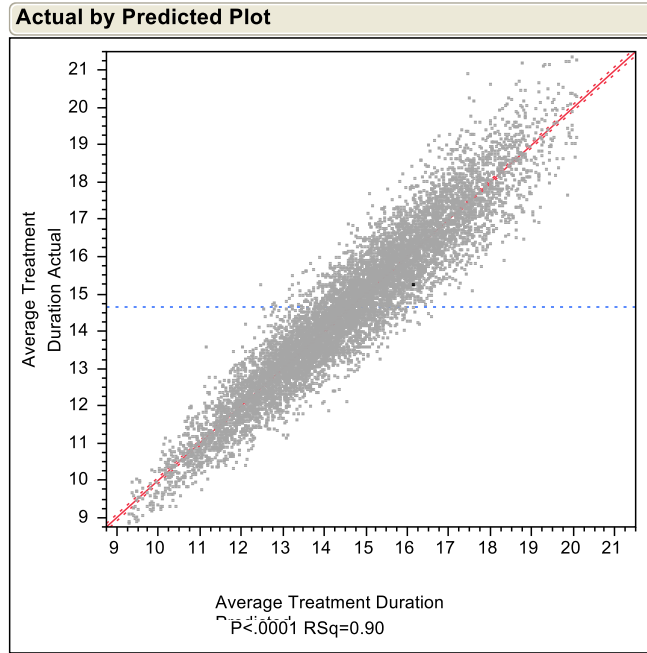

Figure 14. Actual average treatment duration responses predicted by JMP model

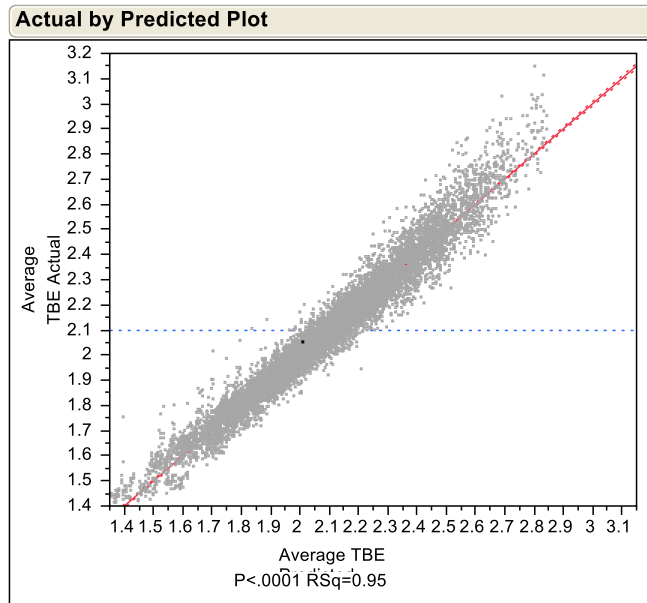

Figure 15. Actual average time-between-encounters responses predicted by JMP model

LIST OF REFERENCES

- Department of Veterans Affairs. (March 12, 2010) *VHA HANDBOOK 1160.03*. Retrieved from VA website:
http://www.va.gov/vhapublications/ViewPublication.asp?pub_ID=2174
- Hoge, C. W., Castro, C. A., Messer, S. C., McGurk, D., Cotting, D. I., & Koffman, R. L. (2004). Combat duty in Iraq and Afghanistan, mental health problems, and barriers to care. *The New England Journal of Medicine*, *351*(1), 13–22.
- Imagine That! ExtendSim Suite, Ver. 8.0.1. San Jose, California.
- SAS Corporation. JMP Ver. 9.0.0. Raleigh, North Carolina.
- Levitt, Raymond E. *Overview of The Virtual Design Team (VDT): A computational model of project teams*. (2009, August).
- Microsoft Corporation. Microsoft Office Professional Plus 2010 Ver. 14.0.5128.5000. Redmond, Washington.
- Microsoft Corporation. Microsoft Visio Premium 2010 Ver. 14.0.5128.5000. Redmond, Washington.
- Monson, C. M., Schnurr, P. P., Resick, P. A., Friedman, M. J., Young-Xu, Y., & Stevens, S. P. (2006). Cognitive processing therapy for veterans with military-related Post-Traumatic Stress Disorder. *Journal of Consulting and Clinical Psychology*, *74*, 898–907.
- Defense Centers of Excellence (DCOE) for Psychological Health & Traumatic Brain Injury. (n.d.). *PTSD: treatment options*. Retrieved from DCOE website:
<http://www.dcoe.health.mil/ForHealthPros/PTSDTreatmentOptions.aspx>
- Schnurr, P. P., Friedman, M. J., Engel, C. C., Foa, E. B., Shea, M. T., Chow, B. K., Resick, P. A., Thurston, V., Orsillo, S. M., Haug, R., Turner, C., and Bernardy, N. (2007). Cognitive behavioral therapy for Post-Traumatic Stress Disorder in women: A randomized controlled trial. *Journal of the American Medical Association*, *297*, 820–830.

THIS PAGE INTENTIONALLY LEFT BLANK

INITIAL DISTRIBUTION LIST

1. Defense Technical Information Center
Ft. Belvoir, Virginia
2. Dudley Knox Library
Naval Postgraduate School
Monterey, California
3. Doug MacKinnon
Naval Postgraduate School
Monterey, California
4. John Osmundson
Naval Postgraduate School
Monterey, California