

# FINAL REPORT

## Pilot-Scale Electrochemical Synthesis of Potassium 2,2-Dinitroethanate

SERDP Project WP-1460

JANUARY 2011

Alexander Paraskos  
Marvin Hawkins  
**ATK Launch Systems**

Tedd Lister  
Robert Fox  
**Idaho National Labs**

Peter Symons  
**Electrosynthesis Inc.**

*This document has been cleared for public release*



**REPORT DOCUMENTATION PAGE**Form Approved  
OMB No. 0704-0188

Public reporting burden for this collection of information is estimated to average 1 hour per response, including the time for reviewing instructions, searching existing data sources, gathering and maintaining the data needed, and completing and reviewing this collection of information. Send comments regarding this burden estimate or any other aspect of this collection of information, including suggestions for reducing this burden to Department of Defense, Washington Headquarters Services, Directorate for Information Operations and Reports (0704-0188), 1215 Jefferson Davis Highway, Suite 1204, Arlington, VA 22202-4302. Respondents should be aware that notwithstanding any other provision of law, no person shall be subject to any penalty for failing to comply with a collection of information if it does not display a currently valid OMB control number. **PLEASE DO NOT RETURN YOUR FORM TO THE ABOVE ADDRESS.**

<b>1. REPORT DATE (DD-MM-YYYY)</b> 01-31-2011		<b>2. REPORT TYPE</b> Final		<b>3. DATES COVERED (From - To)</b> 2005 - 2011	
<b>4. TITLE AND SUBTITLE</b>  Pilot Scale Electrochemical Synthesis of Potassium 2,2-Dinitroethane (KDNE)				<b>5a. CONTRACT NUMBER</b>	
				<b>5b. GRANT NUMBER</b>	
				<b>5c. PROGRAM ELEMENT NUMBER</b>	
<b>6. AUTHOR(S)</b>  Dr. Nick Straessler, Dr. Alex Paraskos, Mr Scott Shultz, Mr. Marvin Hawkins, Mr. Mike Cramer				<b>5d. PROJECT NUMBER</b> WP-1460	
				<b>5e. TASK NUMBER</b>	
				<b>5f. WORK UNIT NUMBER</b>	
<b>7. PERFORMING ORGANIZATION NAME(S) AND ADDRESS(ES)</b>  ATK Launch Systems PO Box 707 9160 N. Hwy 83 Brigham City, UT 84302				<b>8. PERFORMING ORGANIZATION REPORT NUMBER</b>	
<b>9. SPONSORING / MONITORING AGENCY NAME(S) AND ADDRESS(ES)</b> SERDP Weapons Systems and Platforms SERDP and ESTCP Offices 901N. Stuart Street, Suite Arlington, VA 22203-2114				<b>10. SPONSOR/MONITOR'S ACRONYM(S)</b> SERDP	
				<b>11. SPONSOR/MONITOR'S REPORT NUMBER(S)</b>	
<b>12. DISTRIBUTION / AVAILABILITY STATEMENT</b>					
<b>13. SUPPLEMENTARY NOTES</b>					
<b>14. ABSTRACT</b> The purpose of this research is to develop environmentally sound electrochemical methods for the production of DoD materials. More particularly, this particular program will focus on the development and scale-up of electrochemical methods for the synthesis of potassium 2,2-dinitroethanate (KDNE) from nitroethane (NE). KDNE is a key ingredient in the production of 2,2-dinitropropanol (DNPOH), which is in turn an intermediate in the synthesis of several important DoD energetic materials. The production of DoD-related polynitroalkanes <i>via</i> electrochemical routes promises to drastically reduce the waste streams associated with the classical chemical production processes, thereby enabling the production of such energetic ingredients in a more efficient and environmentally-responsible fashion. This is consistent with the SERDP goal of reducing the environmental impact of DoD manufacturing requirements. The research described herein builds upon preliminary bench-scale results obtained at Idaho National Labs (INL) under the previous SERDP-funded Phase I program.					
<b>15. SUBJECT TERMS</b> KDNE, Electrochemistry, polynitoralkanes, 2,2-dinitropropanol, 2,2-dinitroethanate					
<b>16. SECURITY CLASSIFICATION OF:</b>			<b>17. LIMITATION OF ABSTRACT</b>	<b>18. NUMBER OF PAGES</b>	<b>19a. NAME OF RESPONSIBLE PERSON</b> Nathan Seidner
<b>a. REPORT</b>	<b>b. ABSTRACT</b>	<b>c. THIS PAGE</b>			<b>19b. TELEPHONE NUMBER (include area code)</b> 435-863-4486

## INSTRUCTIONS FOR COMPLETING SF 298

**1. REPORT DATE.** Full publication date, including day, month, if available. Must cite at least the year and be Year 2000 compliant, e.g. 30-06-1998; xx-06-1998-, xx-xx-1998.

**2. REPORT TYPE.** State the type of report, such as final, technical, interim, memorandum, master's thesis, progress, quarterly, research, special, group study, etc.

**3. DATES COVERED.** Indicate the time during which the work was performed and the report was written, e.g., Jun 1997 - Jun 1998; 1-10 Jun 1996; May - Nov 1998; Nov 1998.

**4. TITLE.** Enter title and subtitle with volume number and part number, if applicable. On classified documents, enter the title classification in parentheses.

**Ba. CONTRACT NUMBER.** Enter all contract numbers as they appear in the report, e.g. F33615-86-C-5169.

**5b. GRANT NUMBER.** Enter all grant numbers as they appear in the report, e.g. AFOSR-82-1234.

**5c. PROGRAM ELEMENT NUMBER.** Enter all program element numbers as they appear in the report, e.g. 61101A.

**5d. PROJECT NUMBER.** Enter all project numbers as they appear in the report, e.g. 1F665702D1257; ILIR.

**5e. TASK NUMBER.** Enter all task numbers as they appear in the report, e.g. 05; RF0330201; T4112.

**5f. WORK UNIT NUMBER.** Enter all work unit numbers as they appear in the report, e.g. 001; AFAPL30480105.

**6. AUTHOR(S).** Enter name(s) of person(s) responsible for writing the report, performing the research, or credited with the content of the report. The form of entry is the last name, first name, middle initial, and additional qualifiers separated by commas, e.g. Smith, Richard, J, Jr.

**7. PERFORMING ORGANIZATION NAME(S) AND ADDRESS(ES).** Self-explanatory.

**8. PERFORMING ORGANIZATION REPORT NUMBER.**

Enter all unique alphanumeric report numbers assigned by the performing organization, e.g. BRL-1234; AFWL-TR-85-4017-Vol-21-PT-2.

**9. SPONSORING/MONITORING AGENCY NAME(S) AND ADDRESS(ES).** Enter the name and address of the organization(s) financially responsible for and monitoring the work.

**10. SPONSOR/MONITOR'S ACRONYM(S).** Enter, if available, e.g. BRL, ARDEC, NADC.

**11. SPONSOR/MONITOR'S REPORT NUMBER(S).**

Enter report number as assigned by the sponsoring/monitoring agency, if available, e.g. BRL-TR-829; -21 5.

**12. DISTRIBUTION/AVAILABILITY STATEMENT.** Use agency-mandated availability statements to indicate the public availability or distribution limitations of the report. If additional limitations/ restrictions or special markings are indicated, follow agency authorization procedures, e.g. RD/FRD, PROPIN, ITAR, etc. Include copyright information.

**13. SUPPLEMENTARY NOTES.** Enter information not included elsewhere such as: prepared in cooperation with; translation of; report supersedes; old edition number, etc.

**14. ABSTRACT.** A brief (approximately 200 words) factual summary of the most significant information.

**15. SUBJECT TERMS.** Key words or phrases identifying major concepts in the report.

**16. SECURITY CLASSIFICATION.** Enter security classification in accordance with security classification regulations, e.g. U, C, S, etc. If this form contains classified information, stamp classification level on the top and bottom of this page.

**17. LIMITATION OF ABSTRACT.** This block must be completed to assign a distribution limitation to the abstract. Enter UU (Unclassified Unlimited) or SAR (Same as Report). An entry in this block is necessary if the abstract is to be limited.



## TABLE OF CONTENTS

TABLE OF CONTENTS.....	i
LIST OF FIGURES.....	ii
LIST OF TABLES .....	iii
LIST OF SCHEMES .....	iv
LIST OF ACRONYMS AND SYMBOLS.....	v
ACKNOWLEDGEMENT .....	vi
<b>1.0 ABSTRACT .....</b>	<b>1</b>
<b>2.0 OBJECTIVES .....</b>	<b>2</b>
<b>3.0 BACKGROUND.....</b>	<b>2</b>
3.1 Bis(2,2-dinitropropyl)acetal/formal .....	2
3.2 Phase 1 INL Development of Lab-Scale EC Synthesis of KDNE.....	3
<b>4.0 MATERIALS AND METHODS.....</b>	<b>3</b>
4.1 Phase 2 Materials and Methods .....	7
4.1.1 System Setup .....	7
4.1.2 Pilot Plant Engineering and Construction .....	9
4.1.3 Operation Description .....	11
4.1.4 System Troubleshooting and Initial Testing .....	11
4.2 Phase 3 Materials and Methods .....	12
4.2.1 Optimization and Feasibility Study .....	12
<b>5.0 RESULTS AND DISCUSSION .....</b>	<b>13</b>
5.1 Phase 2 Results and Discussion.....	13
5.1.1 Preliminary and Replenishment Test of the EC Process .....	13
5.1.2 Process Chemical Analysis.....	20
5.1.3 Process Time and Operating Capacity.....	21
5.1.4 Volume Increase of Anolyte Solution.....	21
5.1.5 Purity and Yield of KDNE and DNPOH .....	22
5.2 Phase 3 Results and Discussion .....	25
5.2.1 Optimization of EC Process .....	25
5.2.2 Optimization of the Conversion of KDNE to DNPOH .....	33
<b>6.0 PROCESS AND SCALABILITY ASSESSMENT .....</b>	<b>34</b>
6.1 Estimate of In-Production Reaction Yields.....	34
6.2 Basis of Assessment .....	35
6.3 Scaling of the EC Cell .....	36
6.4 Continuous Removal of Byproduct Water .....	39
6.5 Continuous Precipitation of KDNE .....	39
6.6 Scale-up of DNPOH from KDNE.....	40
6.7 Raw Material Costs in Production.....	41
6.8 Waste Streams Generated by Production Process .....	42
<b>7.0 CONCLUSIONS AND IMPLICATIONS FOR FUTURE RESEARCH/IMPLEMENTATION .....</b>	<b>43</b>
<b>APPENDIX A .....</b>	<b>44</b>

## LIST OF FIGURES

Figure		Page
1	The mediated EC oxidation of nitroethane with Fe <sup>2+/3+</sup> .....	4
2	The EC Process for the production of KDNE as developed at INL .....	5
3	Diagram of the continuous-flow bench-scale electrolysis system developed at INL.....	6
4	The bench-scale electrolysis system used at INL .....	6
5	Process flow diagram for the EC synthesis of KDNE at ATK.....	8
6	The pilot-scale EC setup constructed in M-346 Bay 5 at ATK for the Synthesis of KDNE .....	9
7	Computer-based system interface created at ATK for the M-346 pilot-scale EC system.....	10
8	Process trend from Run 3 .....	16
9	Orange gummy by-product in anolyte vessel following Run 3 .....	16
10	FT-IR spectra of the orange by-product from Run 3 and nitroethane .....	17
11	Process Trend from Run 3-1 .....	18
12	Process Trend from Run 4-A .....	19
13	Process Trend from Run 4-B .....	19
14	<sup>1</sup> H and <sup>13</sup> C NMR spectra of KDNE .....	23
15	<sup>1</sup> H and <sup>13</sup> C NMR spectra of DNE .....	24
16	<sup>1</sup> H and <sup>13</sup> C NMR spectra of DNPOH .....	25
17	Process trend from Run 5 .....	26
18	Process trend from Run 5 including reactant and product concentrations .....	27
19	Charge efficiency based on NE consumption in Run 5 .....	28
20	Comparison of UV-VIS peak intensities with anolyte solution concentrations by HPLC .....	29
21	Process trend from Run 7 .....	30
22	Overlay of the NE and DNE concentrations and current profile from Run 7.....	31
23	Evaluation of highest instantaneous yield from pilot scale experiments .....	35
24	Proposed unit operations for production scale synthesis of DNPOH .....	37

## LIST OF TABLES

Table		Page
1	Benefits of the EC synthesis of KDNE; a comparison of estimated process waste streams. ....	7
2	Measured $E_{rp}$ values as a function of mediator ferri/ferro ratio.....	11
3	Standard operating parameters for the pilot-scale EC synthesis system .....	11
4	Operating conditions and results of troubleshooting tests .....	14
5	Operating conditions and results of baseline/replenishment tests.....	15
6	Oxidation/reduction potentials at termination of EC operations.....	20
7	HPLC analysis of anolyte solutions .....	21
8	Theoretical hourly production rates of KDNE .....	21
9	Amounts of starting NE, NE remaining after reaction, and solid KDNE produced in Run 7 .....	32
10	Mass Balance for Run 7 .....	32
11	Results of the laboratory optimization study for the conversion of KDNE to DNPOH.....	33
12	Raw materials consumed by proposed production scale process .....	41
13	Waste stream assessment for proposed EC process .....	42

## LIST OF SCHEMES

Scheme	Page
1	The standard chemical process for the syntheses of DNPOH and BDNPA/F ..... 3
2	The deprotonation of nitroethane by potassium hydroxide (KOH). ..... 5
3	The oxidative nitration of nitroethane ..... 5
4	The oxidation of KDNE radical anion by a second equivalent of ferricyanide ..... 5



## LIST OF ACRONYMS AND SYMBOLS

A/F – Bis(2,2-dinitropropyl)acetal/formal  
ATK – ATK Launch Systems  
BDNPA/F – Bis(2,2-dinitropropyl)acetal/formal  
DI – Deionized  
DNE – 2,2-dinitroethane  
DNPOH – 2,2-Dinitropropanol  
DoD – Department of Defense  
EC – Electrochemical  
 $E_p$  – Oxidation/Reduction Potential  
FT-IR – Fourier Transform Infra-Red  
GPC – Gel Permeation Chromatography  
HPLC – High Performance Liquid Chromatography  
IC – Ion Chromatography  
ICP – Inductively Coupled Plasma  
INL – Idaho National Laboratory  
KDNE – Potassium 2,2-dinitroethanate  
KDNP – Potassium 2,2-dinitropropoxide  
NE – Nitroethane  
NMR – Nuclear Magnetic Resonance  
ORP – Oxidation/Reduction Potential  
SERDP – Strategic Environmental Research and Development Program  
UV-VIS – Ultraviolet-Visible

## **ACKNOWLEDGEMENT**

The financial support of the Strategic Environmental Research and Development Program (SERDP) is acknowledged.

## 1.0 ABSTRACT

Research results aimed at discovering environmentally sound EC methods for the production of Department of Defense (DoD) materials are described. Specifically, this program focused on the development and scale-up of electrochemical (EC) methods for the synthesis of potassium 2,2-dinitroethanate (KDNE) from nitroethane (NE). KDNE is a key ingredient in the production of 2,2-dinitropropanol (DNPOH), which is an intermediate in the synthesis of several important DoD materials. This project was carried out in three phases consisting of a lab-scale development (Phase 1), pilot-plant construction/operation (Phase 2), and optimization of EC process and subsequent conversion of the KDNE to DNPOH (Phase 3). The production of DoD-related polynitroalkanes via EC routes promises to drastically reduce the waste streams associated with the classical chemical production processes, thereby enabling the production of such energetic ingredients in a more efficient and environmentally-acceptable fashion. This is consistent with the overall SERDP goal of reducing the environmental impact of DoD manufacturing requirements. Detailed results of Phase 1 of this project are provided in a separate report.<sup>1</sup>

---

<sup>1</sup> Year End Report FY-2007, SERDP Project # WP-1460, "EC Synthesis of Alkyl Nitro Compounds", ATK Launch Systems and Idaho National Laboratory.

## 2.0 OBJECTIVES

The purpose of this project was to design, build and operate a pilot-scale EC cell and equipment at ATK Launch Systems (ATK) and demonstrate its success by producing KDNE. This was to be achieved through a coordinated collaboration between Idaho National Laboratories (INL), ATK, and Electrosynthesis Inc (pilot-scale EC cell manufacturer). The primary objective of Phases 2 and 3 of the project was to confirm and verify that the laboratory EC synthesis of KDNE at INL (Phase 1) can be accomplished at the pilot-scale. The development and optimization effort focused on determining scalability of the reaction and refinement of the economic feasibility and manufacturing scale potential. The envisioned size-of-scale at the end of the 3-year effort was to be at the pounds-per-hour pilot-scale level. The specific goals were:

1. Demonstrate  $\text{Fe}(\text{CN})_6^{-3/4}$  is a good reaction mediator for the pilot-scale EC synthesis of KDNE.
2. Determine the operating capacity of the EC synthesis system.
3. Evaluate the potential aging effects of KDNE/DNE product in the process solution.
4. Establish the appropriate operating conditions to yield clean KDNE/DNE product by a combination of EC and crystallization processes.
5. Identify other potential process problems and gain experience from the process operation.
6. Demonstrate the clean conversion of electrochemically produced KDNE to DNPOH at the 1 lb/hr level.

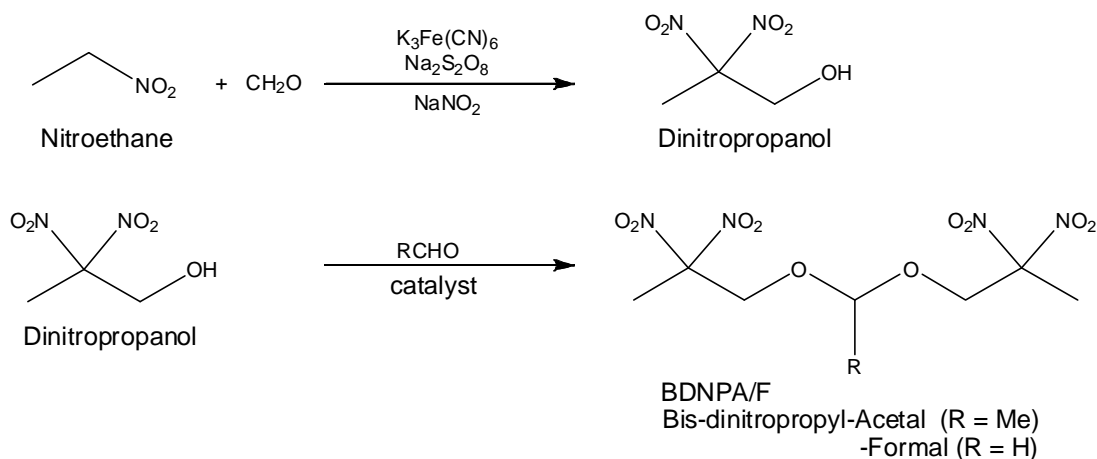
## 3.0 BACKGROUND

### 3.1 Bis(2,2-dinitropropyl)acetal/formal

Bis(2,2-dinitropropyl)acetal/formal (BDNPA/F or A/F) is a nitroplasticizer ingredient used in military explosive/propellant formulations and applications. This material was historically produced on the commercial scale using the ter Meer process.<sup>2</sup> Thiokol Corporation made several improvements/alterations to the process with funding from the US Army (contract # DAA-21-94-D-0003, Task 2). Most notably, the use of carcinogenic and environmentally undesirable chlorinated solvents was eliminated and the process was run as a continuous, "solventless" synthesis up until the extraction/washing steps. This overall process (Scheme 1) was scaled up at ATK (then Thiokol) from the laboratory bench scale to the pilot scale, and ultimately to the production scale.

---

<sup>2</sup> Hamel, E.E.; Dehn, J.S.; Love, J.A.; Scigliano, J.J.; Swift, A.H. *Ind. and Eng.Chem. Prod.Res. and Dev.*, p108 (1962).



**Scheme 1.** The standard chemical synthesis of DNPOH (top) which is used as a starting material in the preparation of the energetic plasticizer BDNPA/F (bottom).

Several serious issues are associated with the chemical BDNPA/F production process. The synthesis of the KDNE, the immediate synthetic precursor to DNPOH, results in the formation of large amounts of corrosive salt waste. It is estimated that in order to produce roughly 200,000 lb of the DNPOH precursor more than 2.5 million pounds of hazardous wastes were generated. The production of DoD-related polynitroalkanes via EC routes promises to drastically reduce the associated waste streams and enable the production of such energetic ingredients in a more efficient and environmentally responsible fashion. This is consistent with the overall SERDP goal of minimizing the environmental impact of DoD materials.

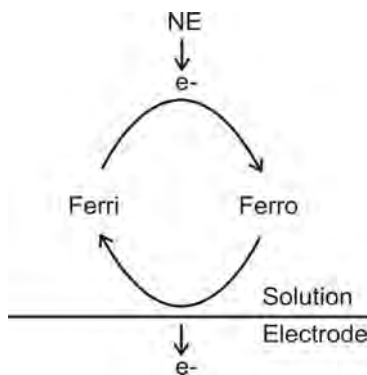
### 3.2 Phase 1 INL Development of Lab-Scale EC Process for KDNE

The EC synthesis of KDNE was successfully demonstrated on the laboratory scale at INL and is described in the corresponding Phase 1 report.<sup>1</sup> The EC synthesis of KDNE from NE was demonstrated along with its subsequent chemical conversion to DNPOH in > 60% overall yield on the bench-top scale.

## 4.0 MATERIALS AND METHODS

The oxidative nitration reaction was attempted directly on electrode surfaces at the early stages of the INL work but resulted in discouraging low observed yields. The prospect for a mediated EC synthetic route involving ferricyanide ions led to an investigation in the Fall of 2006 at INL. Promising results were quickly achieved and a bench-scale optimization study ensued, ultimately providing the scientific basis for the ATK pilot-scale effort described herein. Early development at INL evolved around the use of a typical H-cell EC system. To make the process amendable to the larger scales it was adapted to a continuous flow design.

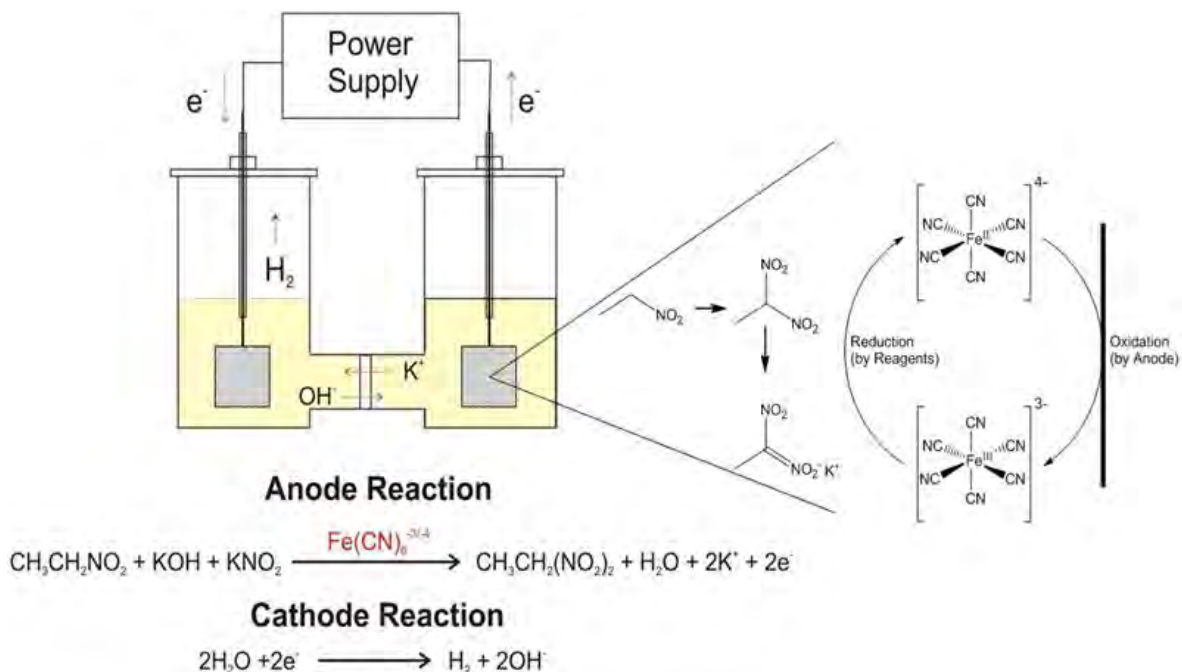
The mediated EC synthesis uses potassium ferricyanide (Fe<sup>+3</sup>) and the reduced ferrocyanide (Fe<sup>+2</sup>) form as the electron shuttle (Figure 1). The electrode eliminates the need for chemical oxidants (such as potassium persulfate) by electrochemically converting the spent ferrocyanide back to the active ferricyanide, thus reducing both materials costs and the associated waste streams.



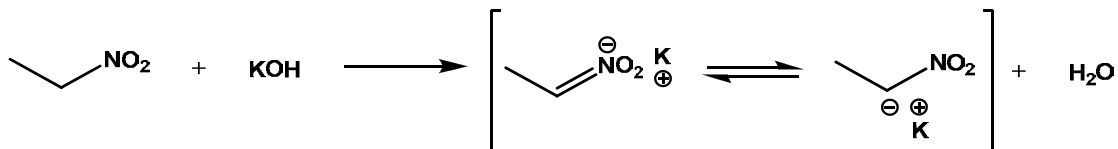
**Figure 1.** The mediated EC oxidation of nitroethane with  $\text{Fe}^{2+/3+}$ .

The oxidative nitration reaction is conducted within the anode compartment of the EC cell (Figure 2). The reaction starts with the deprotonation of nitroethane by the aqueous KOH (Scheme 2). The resulting anion is then oxidized by ferricyanide and the resulting radical reacts with potassium nitrite, forming a dinitroethane radical (Scheme 3), which is further oxidized to KDNE by another equivalent of ferricyanide (Scheme 4). Two ferricyanide ions are therefore required per nitroethane molecule, one to oxidize the NE prior to reaction with the nitrite and another to oxidize the resulting dinitroethane radical anion. The EC reaction rate (applied current) is limited by the concentration and mass transport of the ferrocyanide form of the mediator to the solution. The reverse reaction is limited by the chemical kinetics of the reaction.

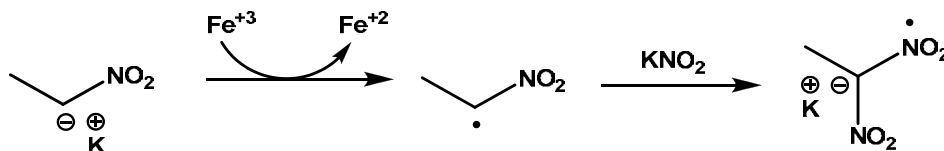
The EC reaction rate can be limited by the chemical reaction rate if the reaction depleting ferricyanide ions is sufficiently slow. If most of the mediator in solution is converted to ferricyanide the current will be diverted into undesired reactions occurring at higher potentials. The cathode reaction involves reduction of water to  $\text{H}_2$  gas and hydroxide ions. The hydroxide produced in the cathode solution is used to maintain the solution pH and to deprotonate the starting NE. The separation of KDNE is realized by exploiting the limited solubility of the product at low temperature, removing it from the reaction solution through precipitation (Figure 3). This enables the continuous addition of starting materials to the original solution as the solid product is removed. Several subsequent regeneration cycles were achieved in the 2006 work. A preliminary analysis of the process developed on the bench-scale at INL (Figure 4) suggests more than a 92% reduction in waste through the use of the EC process for the production of DNPOH (Table 1).



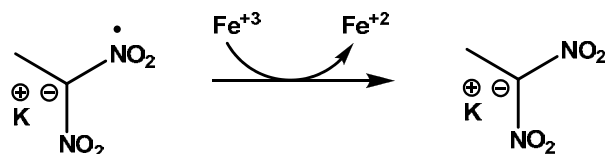
**Figure 2.** The EC process for the production of KDNE as developed at INL. Preliminary results were obtained using a typical H-cell set-up such as that depicted here.



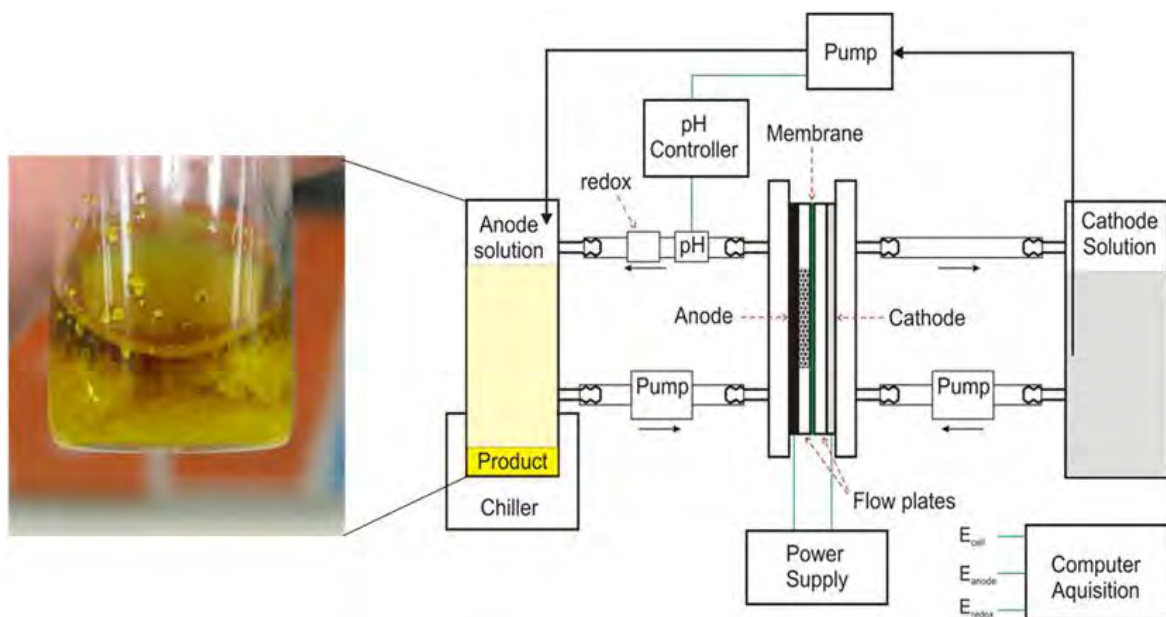
**Scheme 2.** The deprotonation of nitroethane by potassium hydroxide (KOH).



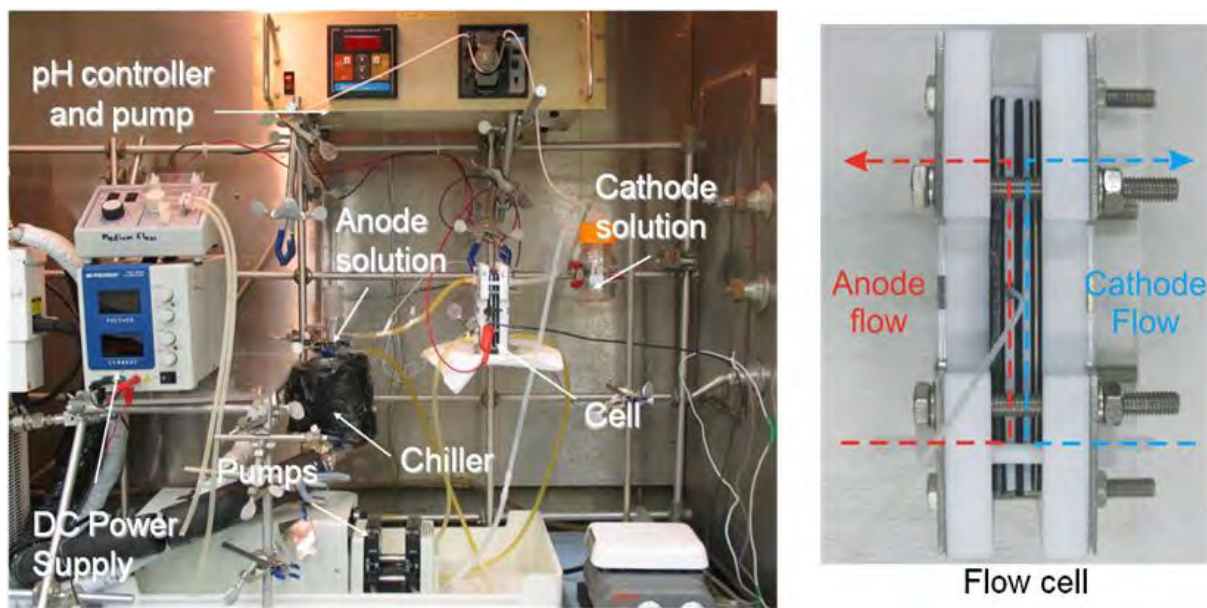
**Scheme 3.** The oxidation of nitroethane by ferricyanide and subsequent nitration with potassium nitrite.



**Scheme 4.** The oxidation of KDNE radical anion by a second equivalent of ferricyanide.



**Figure 3.** Diagram of the continuous-flow bench-scale electrolysis system developed at INL. The product, KDNE, crystallizes from the analyte solution at 0-2 °C (left).



**Figure 4.** The bench-scale electrolysis system used at INL.



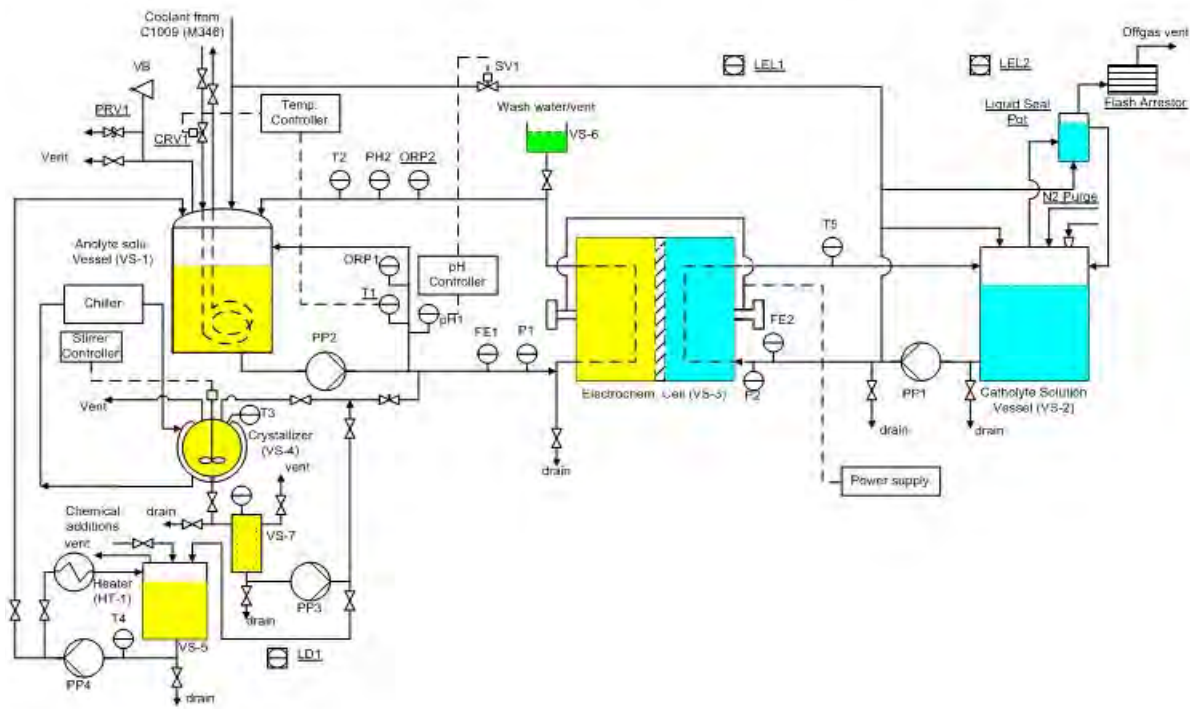
**Table 1.** Benefits of the EC synthesis of KDNE; a comparison of estimated process waste streams.

<b>PRODUCT</b>	<b>ATK DNPOH BDNPA/F Process (LBS)</b>	<b>PRODUCT</b>	<b>Continuous Flow Electrolysis (LBS)</b>
DNPOH	79,500	DNPOH	80,000
<b>WASTE</b>		<b>WASTE</b>	
Water	2,011,000	Water	90,000
Sodium Nitrite	158,000	Potassium Nitrite	21,000
Sodium Bicarbonate	25,000	Potassium Hydroxide	n/a
Ethanates	17,000	Ethanates	9,000
Potassium Ferricyanide	46,600	Potassium Ferricyanide	4,100
Sodium Sulfates	194,000	Sodium Sulfates	0
Formaldehyde	7,700	Formaldehyde	7,700
Sodium Phosphate	65,000	Sodium Phosphate	65,000
<b>TOTAL WASTE</b>	<b>2,524,300</b>	<b>TOTAL WASTE</b>	<b>196,800</b>

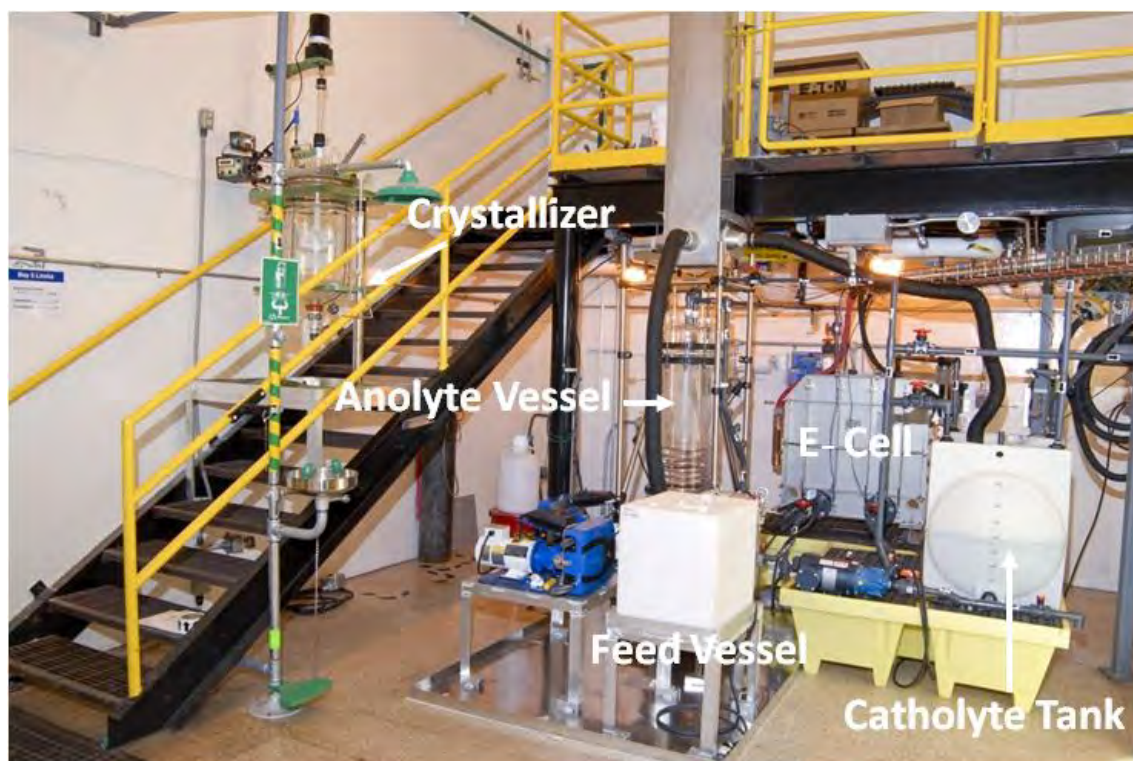
## 4.1 Phase 2 Materials and Methods

### 4.1.1 System Setup

The location of the pilot-scale EC set-up was established in Bay 5 of the M-346 pilot-plant facility at ATK. A simplified diagram of the setup is illustrated in Figure 5 and a photograph of the setup is shown in Figure 6. The EC cell (VS-3, Figure 5) used in this process consists of a carbon felt anode and a nickel cathode separated by a Nafion membrane. The total cell surface area measures 1.2 m<sup>2</sup>. Power to the cell is direct current and can be supplied with a maximum limit of 1200 amps (A) and 8 volts (V). For the test runs a limit of 600 A was maintained. The anolyte reactor (VS-1, Figure 5) is a 50-liter glass cylinder which is approximately 51 inches tall and 10 inches in diameter. This vessel is supported by an exterior frame structure. Due to the concern of potential product decomposition in the anolyte vessel, black plastic (velostat) sheeting was wrapped around the glass vessel to minimize exposure to light. The catholyte solution is contained in a separate plastic reservoir (VS-2, Figure 5). Non-metallic centrifugal pumps are used to circulate the solutions from each reservoir through the EC cell and back to their respective vessels. The chemical oxidation of NE by [+3] ferricyanide (Fe(CN)<sub>6</sub><sup>-3</sup>) reduces the iron mediator to its inactive [+2] state as ferrocyanide (Fe(CN)<sub>6</sub><sup>-4</sup>). As the solution passes through the EC cell the inactive ferrocyanide ions get oxidized back into catalytically active ferricyanide ions at the surface of the anode.



**Figure 5.** Process flow diagram for the EC synthesis of KDNE at ATK.



**Figure 6.** The pilot-scale EC setup constructed in M346 Bay 5 at ATK for the synthesis of KDNE.

#### **4.1.2 Pilot-Plant Engineering and Construction**

During design of the EC pilot plant an extensive hazards analysis and ATK management-level review was required in order to identify and evaluate potentially hazardous situations stemming from the process operation. The release of hydrogen from the catholyte and potential leakage of the anolyte solution (containing the sensitive explosive product) were two hazards for which mitigation was required. Countermeasures such as the use of hydrogen sensors to monitor flammable gas levels, the establishment of secondary containment measures and the implementation of several procedural modifications were adopted to reduce the risk of operation.

In addition, it was decided that the continuous extraction of KDNE product through cooling of the anolyte tank would not be conducted; this decision was made in order to try to avoid a situation in which solid KDNE collected in the process equipment, such as the tubing and/or EC cell as a result of direct cooling. Instead, it was proposed that a separate 30 L jacketed crystallization side tank would be utilized; following EC operation the anolyte solution would be pumped to the crystallization tank for cooling and crystallization. During operation the anolyte solution fed to the EC cell would be kept at roughly room temperature in order to prevent uncontrolled crystallization as well as facilitate product collection. However, the entire volume of product-containing anolyte solution did not fit in the crystallizer used, thereby limiting batchwise crystallizations to only a fraction of the total available solution.

As the electrolysis proceeds, the basic nitroethanate anion is depleted with product formation and the pH of the anolyte solution drops as a result. The anolyte solution is kept at  $\text{pH} > 10$  in order to maintain nitroethane as the deprotonated nitroethanate ion; this is accomplished through the actuation of a

solenoid valve (SV-1, Figure 5) which opens and allows catholyte solution (pH > 12) to flow as necessary into the anolyte vessel. The valve is actuated based on pH measurements taken from the pH 1 (Figure 5) probe.

Once the chemical reaction is complete a portion of the anolyte solution is transferred from the anolyte tank (VS-1, Figure 5) to the crystallizer (VS-4, Figure 5). Cold glycol is cycled through the crystallizer jacket to reduce the temperature of the anolyte solution below its saturation point. Following a given residence time to allow for crystallization, the solid KDNE product is filtered from the cold anolyte solution using a bag filtration unit located downstream of the crystallizer. The filtrate is then pumped to the feed vessel (VS-5, Figure 5) where the depleted starting materials may be replenished as needed in preparation for subsequent runs.

A computer-based data acquisition system and system interface (Figure 7) was designed at ATK to monitor and gather information regarding solution temperatures (T1, T2, T4, and T5, Figure 5), pH (pH1, pH2, Figure 5), amperage, voltage, and oxidation/reduction potentials (ORP: ORP1 and ORP2, Figure 5). Oxidation/reduction potential ( $E_{rp}$ ) measurements are measured at the exit line of EC cell and anolyte solution circulation loop. Applied current (number of electrons) and  $E_{rp}$  are the most important process parameters for the EC synthesis; if the majority of the mediator is converted to ferricyanide the excess current supplied can result in the initiation of undesired reactions occurring at higher electrical potentials. Thus, real-time knowledge of the ferri/ferro ratio is helpful both in understanding and monitoring the reaction. The  $E_{rp}$  is calibrated and verified using standard solutions; calibration curves for five different standards are presented in Table 2. The  $E_{rp}$  increases as the ratio of ferricyanide to ferrocyanide increases. It is thereby possible to monitor the starting material consumption by monitoring  $E_{rp}$  of the anolyte. The operating parameters of the EC synthesis are presented in Table 3.

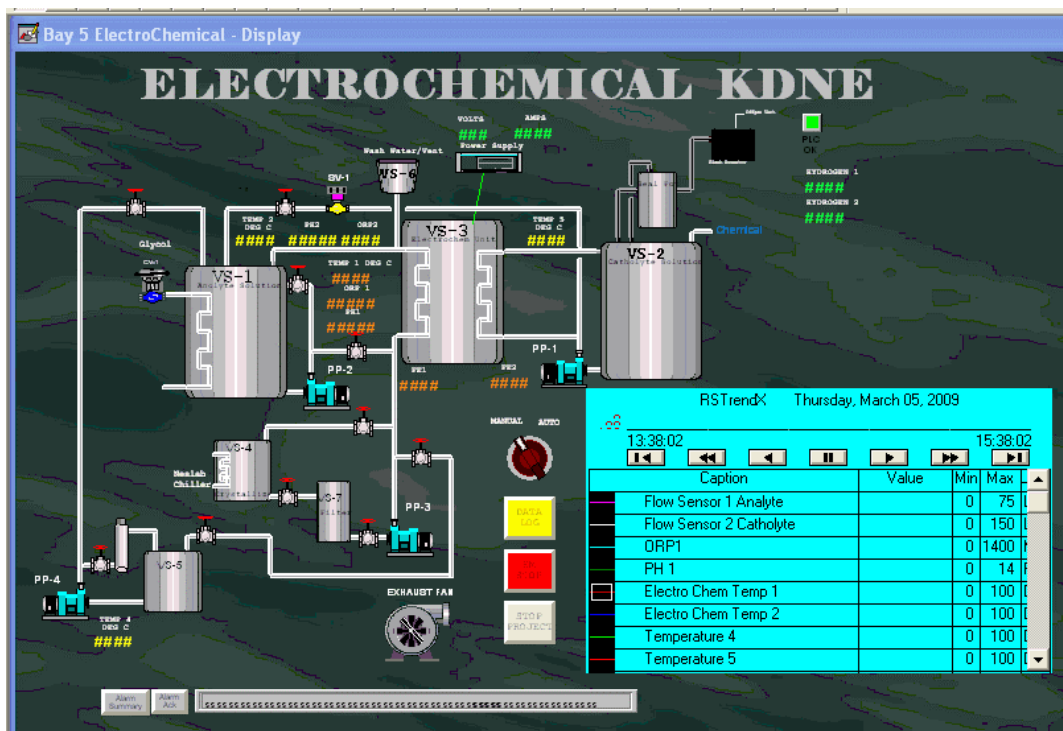


Figure 7. Computer-based system interface created at ATK for the M346 pilot-scale EC system.

**Table 2.** Measured  $E_{rp}$  values as a function of mediator ferri/ferro ratio.

$Fe^{+3}/Fe^{+2}$ ratio	$E_{rp}$ (mV)
0.1/1	136
0.5/1	180
1/1	201
2/1	225
5/1	256

**Table 3.** Standard operating parameters for the pilot-scale EC synthesis system.

Parameters	Range	Parameters	Range	
Current Density ( $A/cm^2$ )	<0.05 (@ 600A)	Anolyte temperature	20 – 35 <sup>o</sup> C	
$E_{rp}$	< 350 mv	Catholyte temperature	Ambient	
Anolyte flow rate	10 – 50 liter/min.	Initial Anolyte Feed	NE	0.2 – 1.2 M
Catholyte flow rate	15 – 80 liter/min.		KOH	0.2 – 1.2 M
Anolyte pH	10 - 13		KNO <sub>2</sub>	0.8 – 0.48 M
Anolyte volume	8 – 14 gal		K <sub>4</sub> Fe(CN) <sub>6</sub> (and K <sub>3</sub> Fe(CN) <sub>6</sub> )	0.1 – 0.16 M
Catholyte volume	40 – 65 gal	Catholyte (KOH)	5 – 11.6 M	

#### 4.1.3 Operation Description

The initial anolyte feed solution was added as separate aqueous solutions or suspensions of the individual components for Runs 1-3. In contrast, the anolyte feed was added as a pre-mixed solution for Run 4. All reagents were added through the anolyte feed vessel (VS5, Figure 5). Once the resulting solution appeared homogeneous it was pumped to the EC cell via the anolyte vessel to initiate the electrolysis and subsequent chemical reactions. The extent of electrolysis reaction was estimated in each case by the calculated theoretical charge, the total delivered charge and the  $E_{rp}$  values recorded during the initial EC process. The theoretical charge is the charge needed to achieve the complete reaction of all the nitroethane in the anolyte solution.

Upon completion of the EC reaction, the power supply was turned off and approximately six gallons (~23 L) of anolyte product solution was transferred to the crystallizer and cooled to 2 - 4 °C to cause precipitation of the KDNE product. After crystallization was complete the crystalline products were filtered using a 5 micron filter bag and the water-wet product was weighed. Typically, a small sample of the collected solid was dried under vacuum until constant weight was achieved in order to estimate the percent water and overall percent yield of KDNE.

#### 4.1.4 System Troubleshooting and Initial Testing

The EC synthesis testing consisted of seven test runs in which equipment troubleshooting was conducted (run 1, 1-1, 2, 2-1, 2-2, 2-3, 2-4) as well as two baseline test runs (run 3, 4-A) and two replenishment runs (run 3-1, 4-B), where depleted materials were replaced and operation recommenced.

## 4.2 Phase 3 Materials and Methods

### 4.2.1 Optimization and Feasibility Study

Following the early EC runs, efforts were focused on optimizing the conditions for both the EC synthesis of KDNE and its subsequent conversion to DNPOH. Additionally, it seemed prudent at this point to examine the scalability of the process and identify additional equipment needed for production-scale EC synthesis of DNPOH, followed by an economic feasibility and manufacturing study. To improve the EC process, development of specific analytical methods was necessary for characterization of the feed solutions and product distribution (mass balance) within the anolyte.

While the purity of the crystallized product produced in the EC process was known to be of extremely high quality, analysis of materials remaining in the anolyte solution was considerably more challenging. Solubilized KDNE product slowly decomposes in the process anolyte solution and when exposed to white light. It was believed that product decomposition between completion of the baseline runs and addition of the replenishment solutions were responsible for the moderate yields observed in the early replenishment tests. In an effort to quantify this and get a decent handle on mass balance several analytical methods were developed for the detection/analysis of both starting materials and products. High-performance liquid chromatography (HPLC) was used for the analysis of NE, DNE and KDNE. Gas chromatography (GC) was used to corroborate the HPLC results for NE. Ion chromatography (IC) was used to investigate concentrations of nitrite in solution. However, concentrations of materials suggested by these analytical methods were not always in good agreement with the expected solution concentrations

Optimization of the feed chemical solution replenishment was conducted in an effort to improve the yield of repeat cycles. The runs were conducted in a continuous batch type of process, with the replenishment operations being conducted immediately following the previous crystallization operations, thereby minimizing the chance of decomposition of materials in solution between runs. This type of operation best represents the round-the-clock operation to be expected in production scale-up operations. Extensive process solution sampling and analysis were conducted to perform mass balance calculations.

The EC process for the production of KDNE was developed at INL using a setup such that the anolyte solution was constantly held at approximately 2 °C both during the operation as well as during any process interruptions. The yield from this process was calculated to be approximately 60% (based on yield of DNPOH on condensation with formaldehyde). The estimated yield of KDNE from the initial ATK pilot-scale studies was 18%; it seemed likely that the discrepancy in the yields was the result of the operating temperature, as this represented one of the single-largest changes between the two setups. The effects of decreasing the temperature on the overall process yield were examined

The effect of increasing the current density was probed while keeping all other variables constant with regard to previous testing. In early runs, current to the cell was held at or below 300 A; in this experiment the current was increased to ~500 A. Increasing the current was expected to increase the reaction rate and in theory would increase the overall output of the cell per unit time. It was speculated that this may also help to decrease the product decomposition in solution, as the overall time from process initiation to crystallization and collection of product should be reduced. However, the possibility of increased side-product formation as a result of increased current density was not discounted.

The effect of decreasing the amount of NE used in the reaction was probed while keeping all other variables constant with regard to previous testing. While this was known to slow the overall reaction rate, it was thought that lowering the concentration of NE may help to reduce the occurrence of undesired side-reactions. In the early runs, significant accumulation of an orange residue was observed in the anolyte tank. While the accumulation of this product did not dramatically affect the operation in previous tests, ultimately such relatively minor side-reactions may severely limit the achievable total continuous reaction time with a given anolyte solution, as the material can build up, affect reaction pathways, and perhaps affect the operation of the cell itself as it flows through the system.

The reaction between KDNE and aqueous formaldehyde is known to be an efficient method to produce DNPOH (potassium salt). Attempts to optimize this process were carried out on the laboratory (< 20 g) scale using KDNE harvested from the pilot-scale process. The specific process parameters that were explored were: 1) concentration of KDNE in water, 2) equivalents of formaldehyde per mol KDNE, and 3) the temperature of the reaction. This provided critical process requirement data to make preliminary design plans for the eventual production-scale conversion of KDNE to DNPOH and aided in the estimation of cost and scalability of the overall NE to DNPOH transformation. The recovered DNPOH was analyzed by FT-IR spectroscopy, HPLC and  $^1\text{H}$  and  $^{13}\text{C}$  NMR spectroscopy and compared to DNPOH produced by the historical chemical processes.

The EC process scalability and economic feasibility of production was assessed, including consideration of additional process equipment needed for production-scale EC synthesis of DNPOH at ATK.

## **5.0 RESULTS AND DISCUSSION**

### **5.1 Phase 2 Results and Discussion**

#### **5.1.1 Preliminary and Replenishment Tests of the EC Process**

During the early troubleshooting runs the system was tested by operating it at brief intervals to identify any equipment shortcomings and unforeseen problems. Valuable operational experience and system familiarity was gained during these runs. Operating conditions for these tests are presented in Table 4. The pH of anolyte solution increased between tests during several of the runs, probably due to migration of hydroxide ions across the membrane from catholyte solution. When the pH increased appreciably, NE was added in order to maintain a pH <13. Significant power supply problems were encountered in the initial runs. It was ultimately determined that the power supply provided by the manufacturer was designed for operation on European electrical grids only. Eventually that power supply was replaced with the United States compatible equivalent. With the power supply problem solved, the first attempt at a complete EC synthesis run (run 2-4) was attempted. This run concluded with a controlled shutdown of the system. During this test the electrical current was gradually increased from 94 A (@1.8 V) to 493 A (@2.8 V), and remained at 493 A for the duration (~144 minutes).

**Table 4.** Operating conditions and results of EC troubleshooting tests.

Run	Anolyte feed solution	Power supply			Comment
		Current (A)	Time (minutes)	Total Charge (coulomb)	
1	0.6 M NE, 0.6 M KOH, 2.4 M KNO <sub>2</sub> , 0.12 M K <sub>4</sub> Fe(CN) <sub>6</sub>	99 – 397	155	2.72 x 10 <sup>6</sup>	EC process terminated early due to failure of power supply
1-1	Same solution from run 1	197	12	1.42 x 10 <sup>5</sup>	EC process terminated early due to failure of power supply
2	0.6 M NE, 0.6 M KOH, 2.4 M KNO <sub>2</sub> , 0.12 M K <sub>4</sub> Fe(CN) <sub>6</sub>	99 – 297	58	7.58 x 10 <sup>5</sup>	EC process terminated early due to failure of power supply
2-1	Added 150 ml NE to anolyte product solution from run 2	NA	0	0	Added NE to adjust anolyte pH, no output from power supply
2-2	Added 200 ml NE to anolyte solution from run 2-1	NA	0	0	Added NE to adjust anolyte pH, no output from power supply
2-3	Same solution from run 2-2	NA	0	0	No output from power supply
2-4	Added 500 ml NE to anolyte solution from run 2-3	99 – 495	144	3.04 x 10 <sup>6</sup>	Added NE to adjust anolyte pH, test run successful

Following the first successful complete run (2-4), two baseline and two replenishment tests were conducted to evaluate the potential performance of the EC system and its capacity to support a production scale application. The two baseline tests, Runs 3 and 4-A, were conducted with fresh anolyte solutions. After the baseline tests, the solid KDNE products were filtered and isolated as water-wet material (drying of the bulk KDNE was avoided due to the explosive sensitivity of the dry material). Based on the molar quantity of material removed by filtration additional NE, KOH, and KNO<sub>2</sub> were added for the replenishment tests (Runs 3-1 and 4-B). The replenishment solutions were mixed with the combined filtrate solutions and anolyte solutions remaining from the baseline tests. The operating conditions and results of the two baseline and two replenishment tests are summarized in Table 5.



**Table 5.** Operating conditions and results of baseline/replenishment tests

Run No. date	Analyte feed solution			Power supply			Wet KDNE yield		
	*Solution and total NE	Initial Vol. (gal)	Final Vol. (gal)	Theoretical charge*** (coulomb)	Test data			Wet KDNE(g)/ 6 gal solution	H <sub>2</sub> O %
					Current (A)	Time (min)	Tot charge (coulomb)		
3 Apr 8, 9	A/31.4 moles NE (2.3 L)	12	13.5	$6.06 \times 10^6$	94 - 497	165	$4.63 \times 10^6$	847	~45
3-1** Apr 15	B/9.26 moles NE	12	12	$1.79 \times 10^6$	195	40	$4.68 \times 10^5$	118	NA
4-A Apr 28, 29	C/23.6 moles NE (1.73 L)	9	9.5	$4.56 \times 10^6$	48 - 295	221	$3.45 \times 10^6$	837	~37
4-B** Apr 30	D/8.38 moles NE	10	10	$1.62 \times 10^6$	99 - 197	66	$5.8 \times 10^5$	242	~37

\*Solution: A: fresh solution 0.69 M NE, 2.4 M KNO<sub>2</sub>, 0.12 M K<sub>4</sub>Fe(CN)<sub>6</sub>, 0.69 M KOH; B: mixed solution from 6 gal anolyte product solution (run 3) + anolyte filtrate solution (run 3) + replenish solution (replenish solution: 210 ml NE + 250 ml KOH solution (45.1%) + 247 g KNO<sub>2</sub> + DI water, volume 800 ml), discarded 1.5 gal anolyte product solution from run 3; C: fresh solution 0.69 M NE, 2.4 M KN O<sub>2</sub>, 0.09 M K<sub>4</sub>Fe(CN)<sub>6</sub>, 0.03 M K<sub>3</sub>Fe(CN)<sub>6</sub>, 0.69 M KOH; D: mixed solution from leftover anolyte product solution (run 4-a) + anolyte filtrate solution (run 4-A) + water rinse + replenish solution (replenish solution: 210 ml NE + 250 ml KOH solution (45.1%) + 247 g KNO<sub>2</sub> + DI water, volume 1 liter)

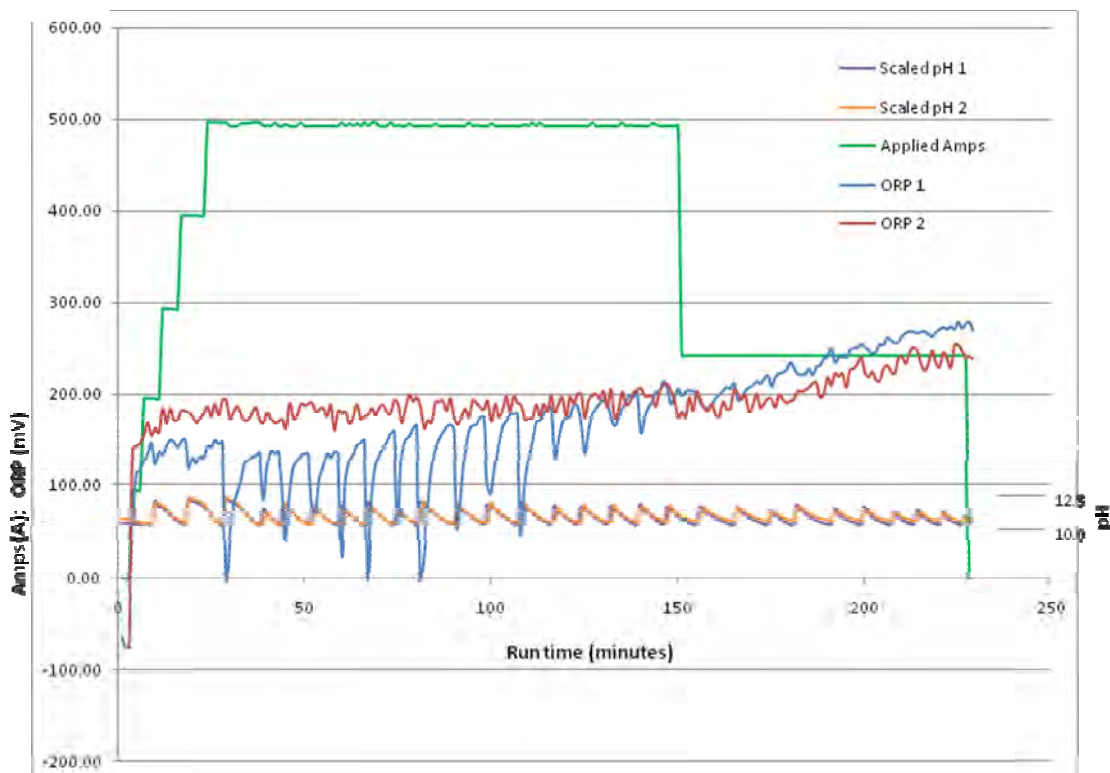
\*\*Total NE was calculated base on the estimated un-react NE from the baseline run and additional NE from replenish solution

\*\*\*Theoretical charge was base on all the NE that may present in anolyte feed solution, theoretical charge for reaction with 210 ml NE in replenish solution is  $5.65 \times 10^5$

The baseline and replenishment tests were run with few problems, and no major shutdowns experienced due to operational difficulties. Baseline test Run 3 and its replenishment test Run 3-1 were terminated after approximately 165 and 40 minutes of operation, respectively. Run 4-A and its replenishment test Run 4-B were terminated after 221 and 66 minutes of operation, respectively. Both baseline tests were terminated when the overall process electrical input was greater than 75% of the theoretical charge required to convert all starting nitroethane to dinitroethane. The theoretical charge was based upon the known amount of NE reactant in the original anolyte solution. However, the exact amount of NE in the replenished solutions was not known; both replenishment tests (run 3-1, 4-B) were terminated based on the theoretical charge calculated from the amount of NE added within the replenishment solution coupled with the reading from  $E_{rp}$ . A longer operating time (and higher electrical charge) was adapted for run 4-B in an attempt to achieve a higher yield of KDNE.

The anolyte feed solution for Run 3 was prepared in the feed vessel; an additional 300 mL of NE was then injected to adjust the solution pH prior to transferring to the anolyte vessel. It is possible that this mixed solution not was fully homogenized prior to the transfer. The process trend from Run 3 is shown in Figure 8. Two days following termination of the EC synthesis process an unanticipated orange gummy material was observed on top of the cooling coils, on the inner glass surfaces, and floating on top of the

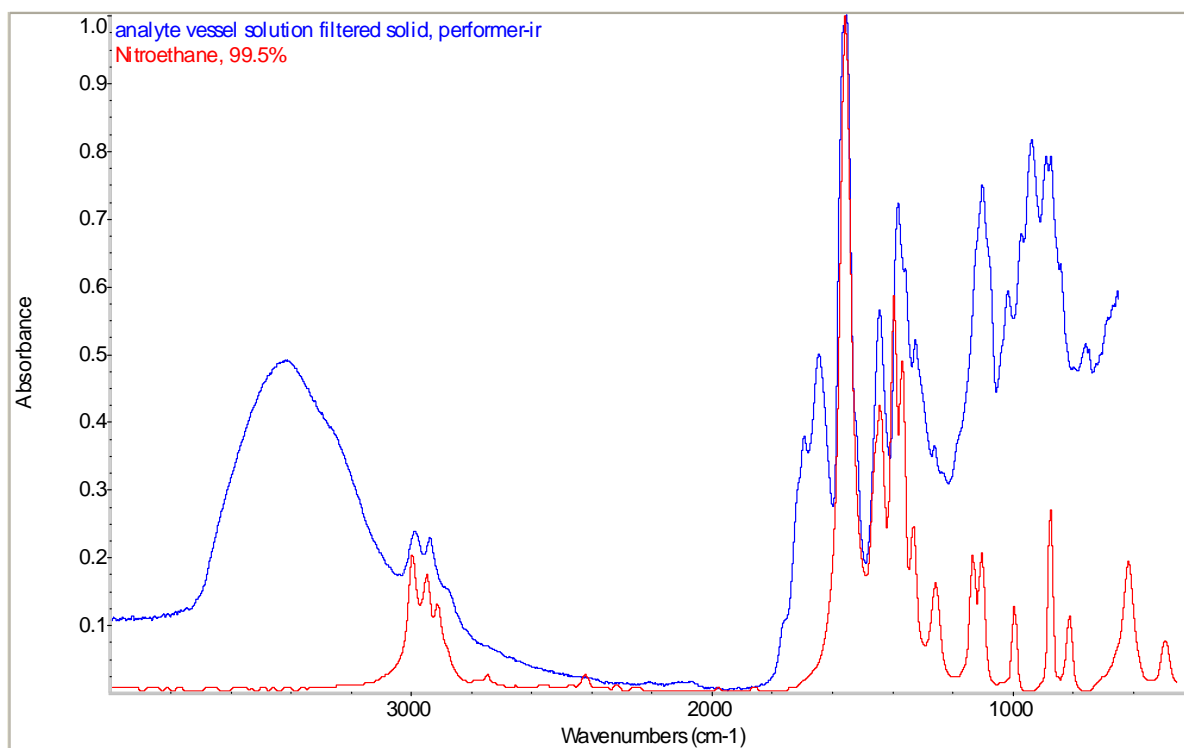
anolyte solution (Figure 9). Regardless, the crystallization and filtration processes were completed as planned. A sample of the unknown orange residue was collected and analyzed; FT-IR spectroscopic analysis (Figure 10) identified the unknown as predominantly NE with a small percentage of unidentified iron species (detected by inductively coupled plasma analysis), which presumably accounts for the orange color. HPLC and gel permeation chromatography (GPC) analyses of the unknown were inconclusive.



**Figure 8.** Process trend from Run 3. The pH clearly oscillates, decreasing gradually with potassium ethanate depletion and then suddenly rising with addition of KOH-containing catholyte solution. The ORP gradually climbs as expected as the available nitroethane is depleted.

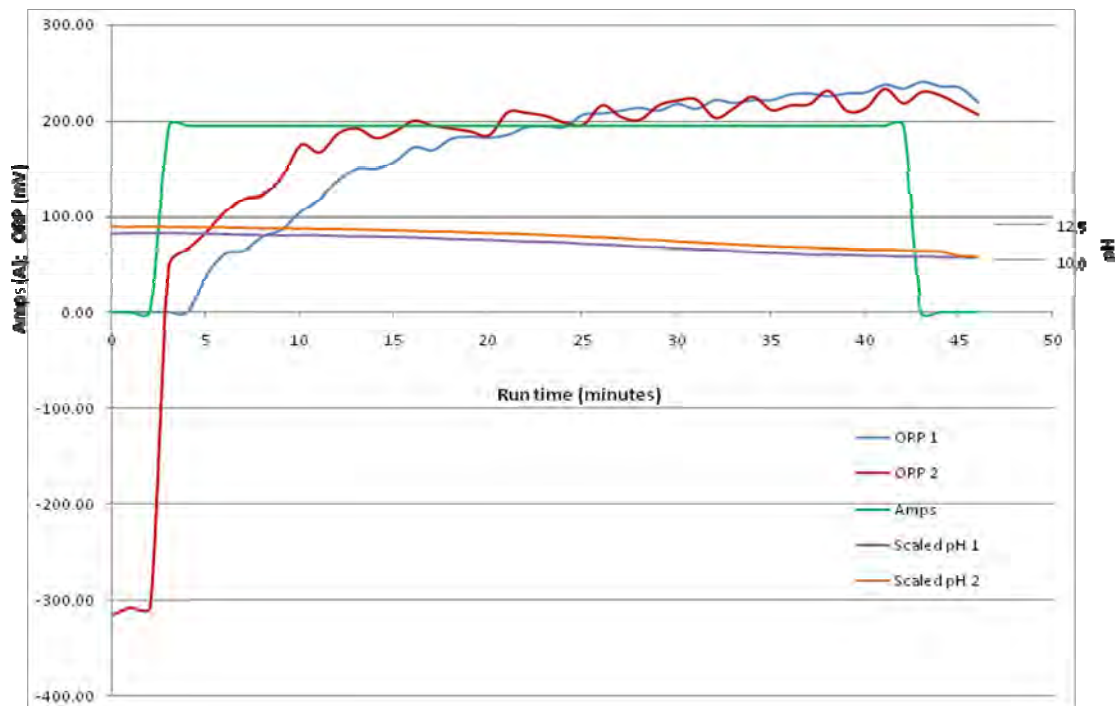


**Figure 9.** Orange gummy by-product in analyte vessel following Run 3.



**Figure 10.** FT-IR spectra of the orange by-product from Run 3 (blue) and nitroethane (red).

Run 3-1 began one week after termination of Run 3; the trend data for Run 3-1 is shown in Figure 11. At the start of Run 3-1 the pH of anolyte solution had dropped to  $\sim 7.6$  (from an initial value of pH 10.2 measured immediately following run 3). The most likely cause of the change in pH is the gradual decomposition of the KDNE in solution over time.



**Figure 11.** Process trend from Run 3-1.

To ensure homogeneity of the anolyte feed solution prior to run 4-A the NE and KOH solution mixture was first prepared and thoroughly mixed by manual agitation of the solution carboy before introduction to the anolyte feed vessel. The aqueous solutions of  $\text{KNO}_2$  and  $\text{K}_4\text{Fe}(\text{CN})_6$  were then added and the solution mixture was circulated in the feed vessel to ensure mixing prior to transport to the anolyte vessel. A brief shutdown was encountered during run 4-A due to a small leak that developed on the circulation loop of anolyte vessel. The leak was regarded as being insignificant for Run 4-A, and was fixed prior to run 4-B. The data trends of solution pH,  $E_{rp}$ , and the applied current for Run 4-A are shown in Figure 12. Clearly visible in the trend are the continuous automated pH adjustments to the solution and the gradually increasing  $E_{rp}$  during operation. Following Run 4-A the amount of unknown material deposited on the interior of the anolyte vessel was greatly reduced compared to the prior run. Significant crystalline yellow precipitate (KDNE) was visible both at the bottom of anolyte vessel and in the anolyte product solution samples the next day, indicating that the yield of KDNE was high enough that the saturation temperature of the solution was greater than room temperature. The actual saturation temperature was determined in the lab by heating a sample of the solution until all the KDNE was dissolved and then slowly cooling until turbidity was observed in the solution due to recrystallization. The measured saturation temperatures for the anolyte product solution from Run 4-A was  $28^\circ\text{C}$ . In retrospect, it would appear that the decision to run using a non-continuous (batch) crystallization strategy may not have been entirely preferable; the use of a batch-wise crystallization scheme was adopted in order to avoid unintended crystallization within the system, yet it was found in Run 4-A that this can occur even at room temperature. It is likely that a continuous recrystallization

scheme may ultimately prove preferable, as the crystallization would gradually occur in a pre-determined location rather than throughout the system.

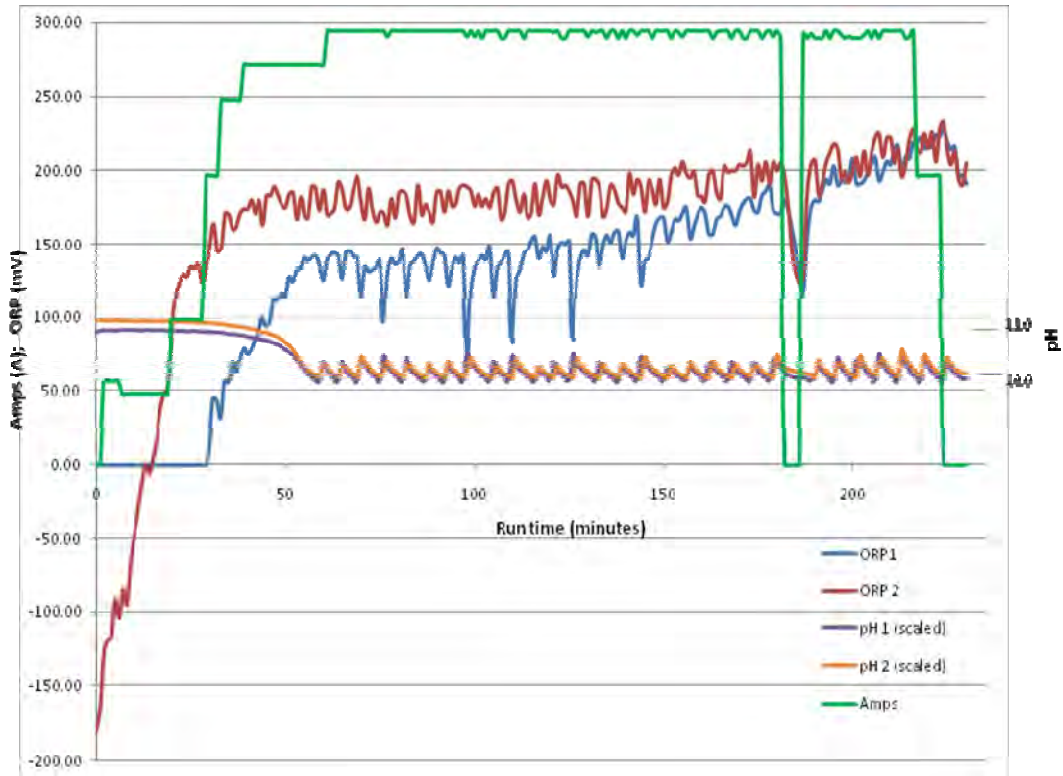


Figure 12. Process trend from Run 4-A.

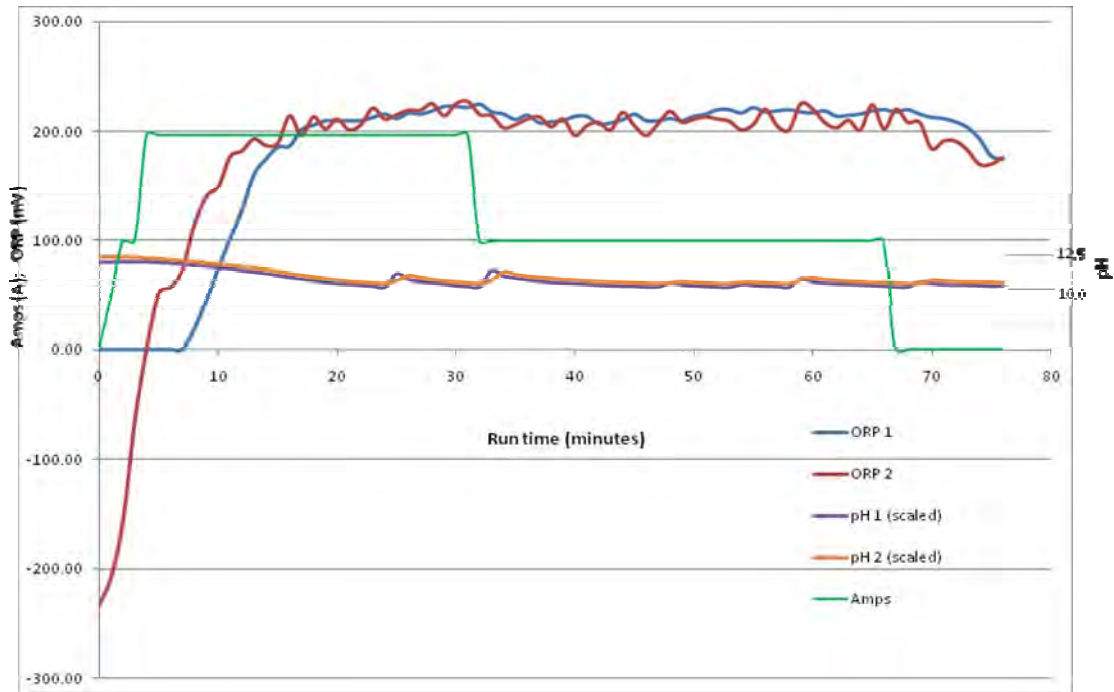


Figure 13. Process trend from Run 4-B.

Replenishment Run 4-B was conducted with more electrical current than run 3-1. The data trend for Run 4-B can be seen in Figure 13. More KDNE product was collected from this particular replenishment test than in 3-1, likely due to the fact that it was within 18 hours of completion of run 4-A rather than allowing solution to age for a week. Sample 4-B did not contain solid KDNE at room temperature; for this sample the solution was cooled slowly until turbidity was observed due to crystal growth. The measured saturation temperature for sample 4-B was 8 °C. The temperature difference between the two samples is clearly due to a greater concentration of KDNE in the 4-A sample relative to the 4-B sample. Ultimately, it may prove important to quantify the KDNE saturation concentration versus temperature for production applications to maximize process yield.

Table 6 summarizes the ORP readings at the point of process termination for Runs 3, 3-1, 4-A, and 4-B. This table can be used in conjunction with Table 4 to compare and contrast the results of these runs. The calculated total charge efficiency based on the total charge (number of electrons) and the theoretical charge (based on the amount of NE) was 76.4% for run 3 and 75.7% for run 4-A.

**Table 6.** Oxidation/reduction potentials at termination of EC operations.

Run No.	ORP1 (mv)*	ORP2 (mv)*
3	216 – 230	236 – 250
3-1	191 – 212	214 – 228
4-A	188 – 210	214 – 222
4-B	201 – 208	209 – 215

\*Reading of the last 10 – 15 minutes of EC run, prior to termination of the power supply.

Crystallization and solid/liquid separation of KDNE from the anolyte product solutions was relatively trouble-free. After the EC process was complete the anolyte product solution was introduced to the pre-cooled crystallizer and allowed to cool for ~ 2 hours with agitation then stirred at ~2 to 4 °C for another 45 to 60 minutes. The KDNE precipitate was vacuum filtered and collected in a filter bag . The optimal cooling profile for crystallization was not investigated and the crystal size distribution of KDNE product from the EC synthesis process was not determined.

### 5.1.2 Process Chemical Analyses

In order to complete a mass balance on the entire system, several parameters needed to be quantified. Quantitative analysis of the starting materials and products within reaction solutions proved more challenging than originally anticipated as the analytical results of samples taken from Runs 4-A and 4-B did not match the expected values.

Several analytical methods were developed for the detection and analysis of anolyte starting materials and product. HPLC was used for the analysis of NE, KDNE, and dinitroethane (DNE). Analytical results by HPLC for both anolyte starting and product solutions from Runs 4-A and 4-B are presented in Table 7. Due to the potential for decomposition of the KDNE product, the anolyte product solutions were analyzed several times within three days to evaluate decomposition. GC analysis was used to corroborate the HPLC results for NE; these results were in close agreement with the HPLC data.

**Table 7.** HPLC analysis of anolyte solutions.

Run 4-A	Age (hr)*	pH**	NE (molar)	DNE/KDNE (molar)
Anolyte Initial	0	11	0.033	0.009
Anolyte Product	0	8	<0.005	0.257
	18	8	<0.005	0.178
	24	8	<0.005	0.178
	42	8	<0.005	0.181
	48	8	<0.005	0.176
	72	8	<0.005	0.174
Run 4-B	Age (hr)	pH	NE (molar)	DNE/KDNE (molar)
Anolyte Initial	0	10	<0.005	0.114
Anolyte Product	0	10	<0.005	0.155
Filtrate (from crystallizer)	0	10	<0.005	0.094

\* Original sample was prepared for analysis at the time listed (age)

\*\* Measured using litmus paper

The initial solution concentrations of NE as prepared were ~0.69 M; however, the analytically-determined initial NE concentrations were not in agreement with this value, making mass balance calculations difficult. Yellow precipitate (KDNE) was observed in the anolyte product solution at ambient temperature, which may have caused some of the discrepancy in the analytical methodologies. Preliminary chemical analyses indicate that approximately 30% of KDNE in the original sample solution decomposed in the first 18 hours; the remainder was stable for two days.

### 5.1.3 Process Time and Operating Capacity

In addition to processing time required for the EC synthesis, the crystallization process takes approximately 2 ½ to 3 hours for a six gallon batch of anolyte solution. The process time to produce KDNE is dependent upon the current supplied to the cell, the solution volume, and the NE concentration in the anolyte solution (Table 8). However, the actual realized production rate is dependent on the system configuration and varies depending on the specific operating procedure used.

**Table 8.** Theoretical hourly production rates of KDNE.

Current (A)	Electricity (C)	Mole (g) NE reacted*	KDNE (lb)
100	$3.6 \times 10^5$	1.87 (140)	0.66
200	$7.2 \times 10^5$	3.73 (280)	1.32
300	$1.08 \times 10^6$	5.61 (420)	1.98
600	$2.16 \times 10^6$	11.19 (840)	3.94

\*Two moles of electron are required to convert one mole of NE to KDNE

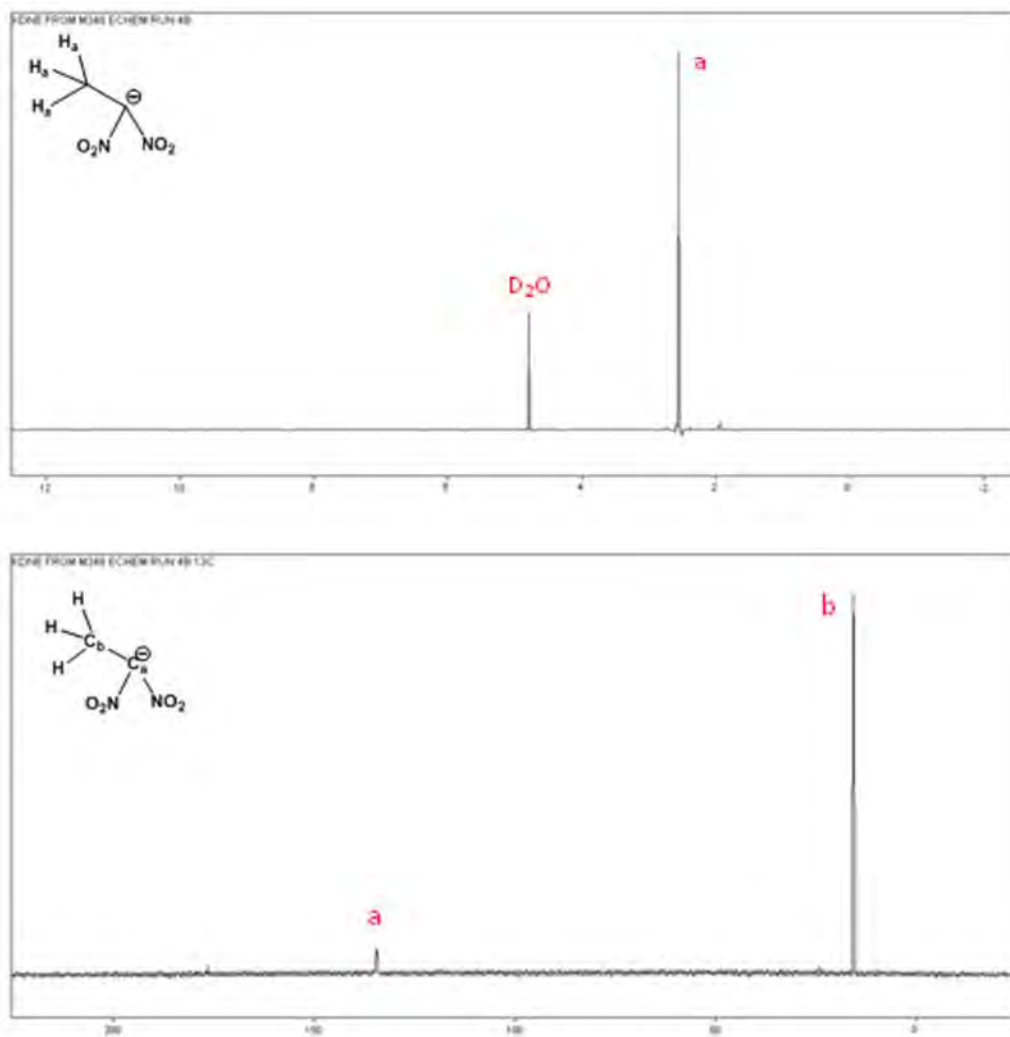
### 5.1.4 Volume Increase of Anolyte Solution

Following Run 3 the analyte solution volume had increased by more than 10% (from 12 gallons to approximately 13.5 gallons). The volume increase for run 4-A was 0.5 gallons, from 9 gallons to 9.5 gallons. A small fraction of the increase is attributable to the formation of water from the chemical reaction. The replenishment solutions also contribute to the volume increase. However, the majority of the volume increase is attributed to pH adjustments made by automatic injection of catholyte solution (5 M KOH) to the analyte vessel during the operation. Further evaluation is needed in order to minimize the overall solution volume increase over time in an effort to streamline the process for production.

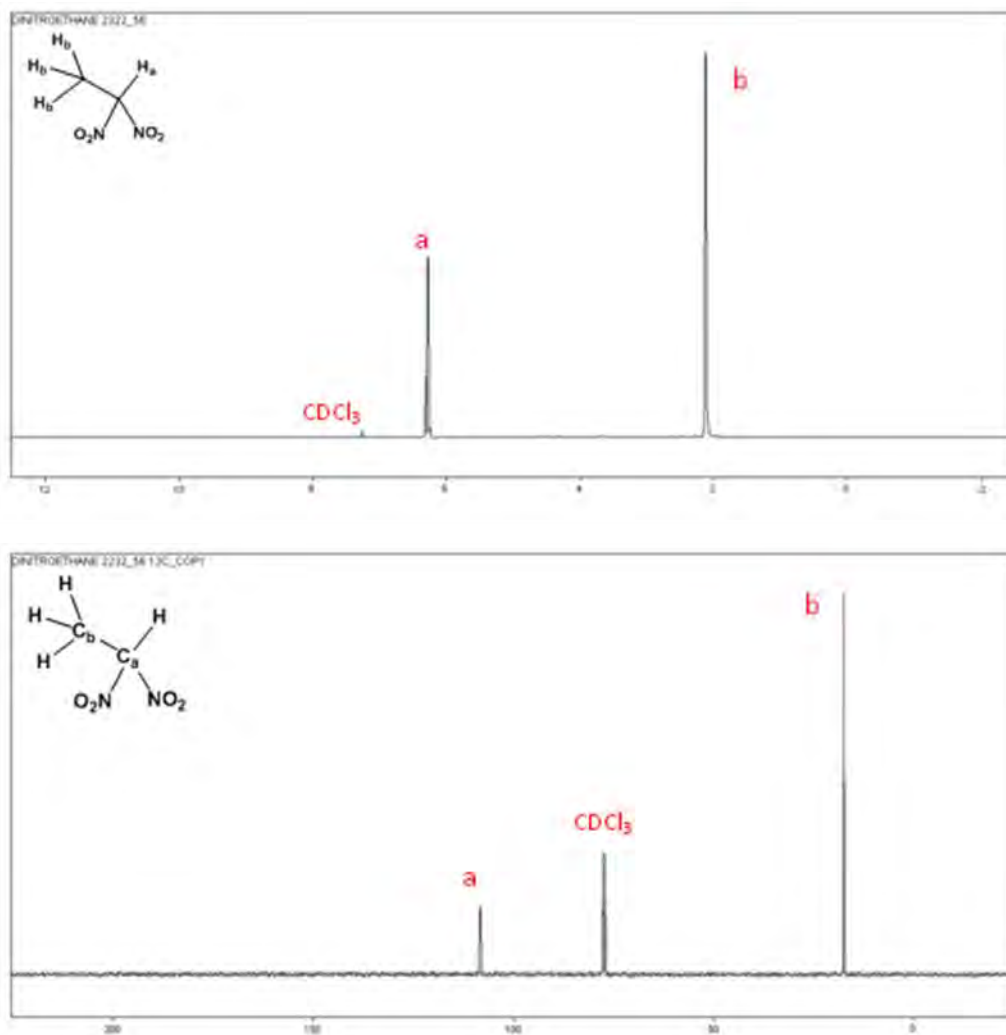
#### **5.1.5 Purity and Yield of KDNE and DNPOH**

The precipitated KDNE generated in the baseline and replenishment tests were yellow crystalline solids. They were isolated without difficulty by filtration.  $^1\text{H}$  and  $^{13}\text{C}$  NMR spectroscopic analyses of the solid samples indicated that the product consisted of high purity KDNE (Figure 14). The KDNE was also protonated (brought to pH 4-5 with 1 M phosphoric acid) and the resulting DNE was analyzed by  $^1\text{H}$  and  $^{13}\text{C}$  NMR spectroscopy. These spectra also indicated very high purity of material (Figure 15). Finally, the KDNE was converted to DNPOH on the lab scale. For the conversion to DNPOH 1.5 molar equivalents of 37% aqueous formaldehyde was added to KDNE dissolved in approximately 10 weight equivalents of water. Prior to formaldehyde addition, one drop of 45.1 wt% aqueous KOH was added to bring the pH to 10-11. The reaction was stirred for 40 minutes then acidified to pH 4-5 through the addition of 1M aqueous phosphoric acid solution. The resulting DNPOH product was extracted with ethyl acetate (2 x 50 ml), the organics were dried over magnesium sulfate and filtered to remove the drying agent. Upon solvent removal *in vacuo*, DNPOH was recovered as a waxy solid in nearly quantitative yield from KDNE. The  $^1\text{H}$  and  $^{13}\text{C}$  NMR spectra indicate that the DNPOH is highly pure (Figure 16).

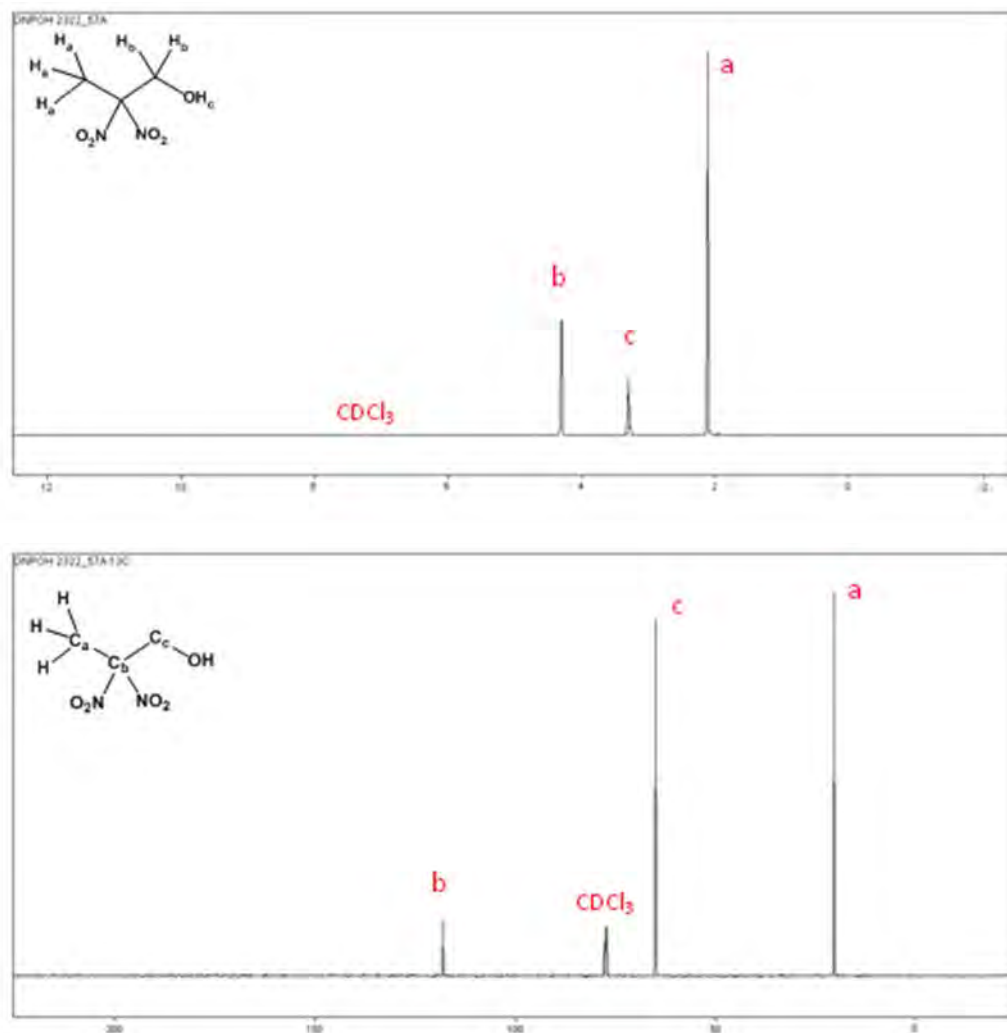




**Figure 14.** <sup>1</sup>H (top) and <sup>13</sup>C (bottom) NMR spectra (D<sub>2</sub>O) of KDNE recovered from Run 4-B.



**Figure 15.** <sup>1</sup>H (top) and <sup>13</sup>C (bottom) NMR spectra (CDCl<sub>3</sub>) of DNE obtained by protonation of KDNE recovered from Run 4-A.



**Figure 16.**  $^1\text{H}$  (top) and  $^{13}\text{C}$  (bottom) NMR spectra ( $\text{CDCl}_3$ ) of DNPOH prepared by formylation and subsequent protonation of KDNE recovered from Run 4-A.

## 5.2 Phase 3 Results and Discussion

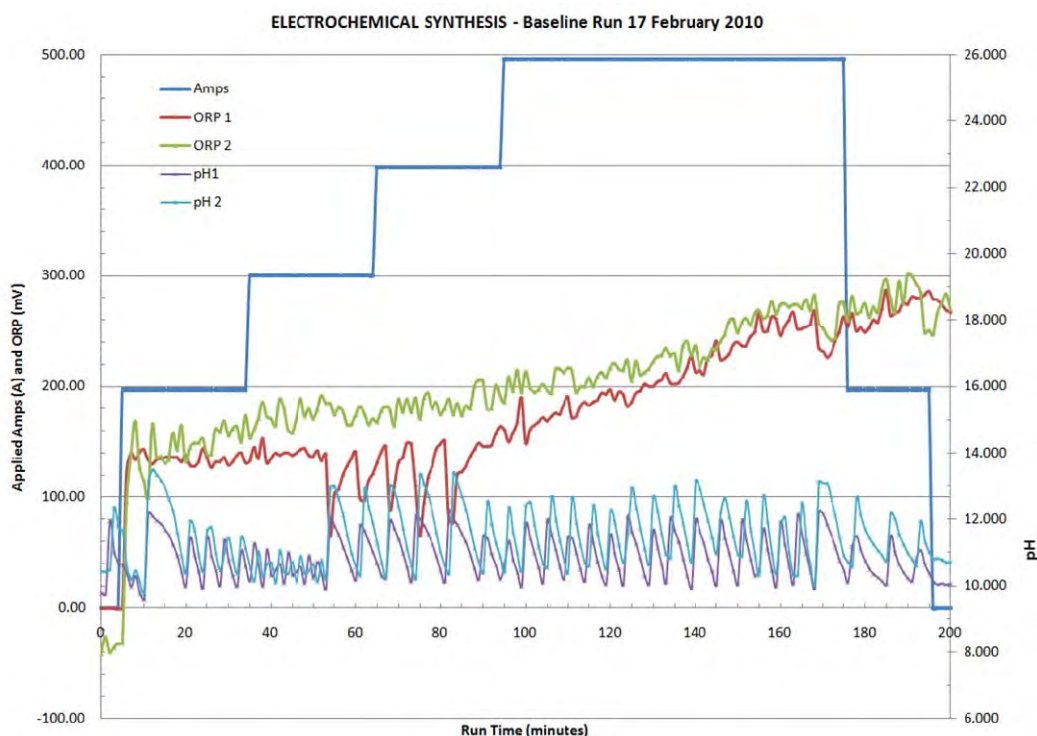
### 5.2.1 Optimization of EC Process

Throughout the development of the pilot-scale EC process, quantitative analysis of the starting materials and reaction products had proven quite challenging. This is due to the multiple dynamic equilibria occurring in the analyte solution. The HPLC method being used to track the NE starting material and KDNE product in solution was found to be unreliable and highly pH-dependent. As a result, it was not possible to produce accurate mass balances for the reaction. For this reason, significant effort was spent to verify that the methods being used for the quantitative determination were in fact achieved prior to spending additional resources on continuing the synthetic efforts. Indeed, the HPLC methodology was improved by using a buffer solution to neutralize the analyte solution prior to injection into the column; the instrument conditions were also improved in order to increase the reliability of the results. The repeatability of this HPLC method was tested by preparing several representative analyte solutions with known concentrations of NE, KDNE,  $\text{KNO}_2$  and  $\text{K}_4\text{Fe}(\text{CN})_6$ . These

solutions were then submitted for HPLC analysis and the reported results corresponded for all components to +/- 5% with the known concentrations.

With the improved analytical techniques established, planning for Run 5 was finalized. In preparation for the run a sampling port was installed at the cell outlet such that frequent sampling could be accomplished at predetermined points in the EC run. The plan was to operate at 200 A, then 250 A, then 300 A, then 400 A, and then 500 A while observing the oscillations in ORP over these currents. The pH drift was confined to 10-13 and the NE and KOH concentrations in the starting anolyte solution were decreased to 0.6 M in accordance with the best results obtained by the INL team on the bench scale optimization study. The run was conducted in a batch mode in order to allow for direct comparison to the past runs before making any alterations to the system in preparation for moving to a semi-continuous mode of operation.

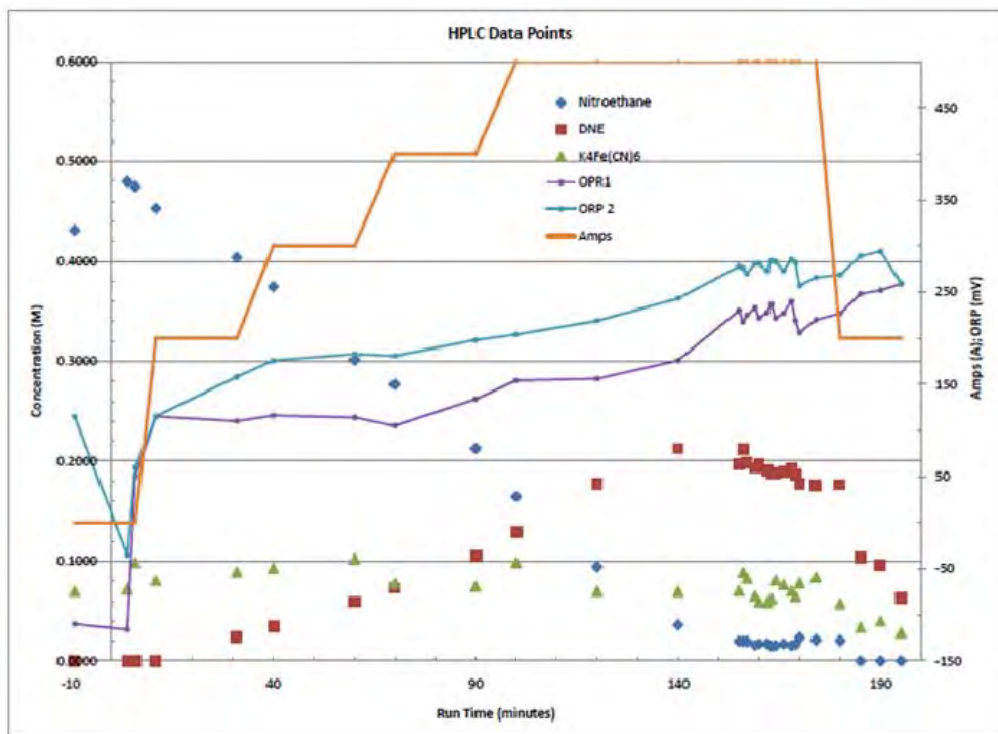
In total, 29 samples were collected and analyzed from the outlet of the EC cell through the course of the reaction. The solutions were analyzed by HPLC to determine the concentrations of constituents over time. The process trend from Run 5 is shown in Figure 17, below. These parameters all traced nominally as expected.



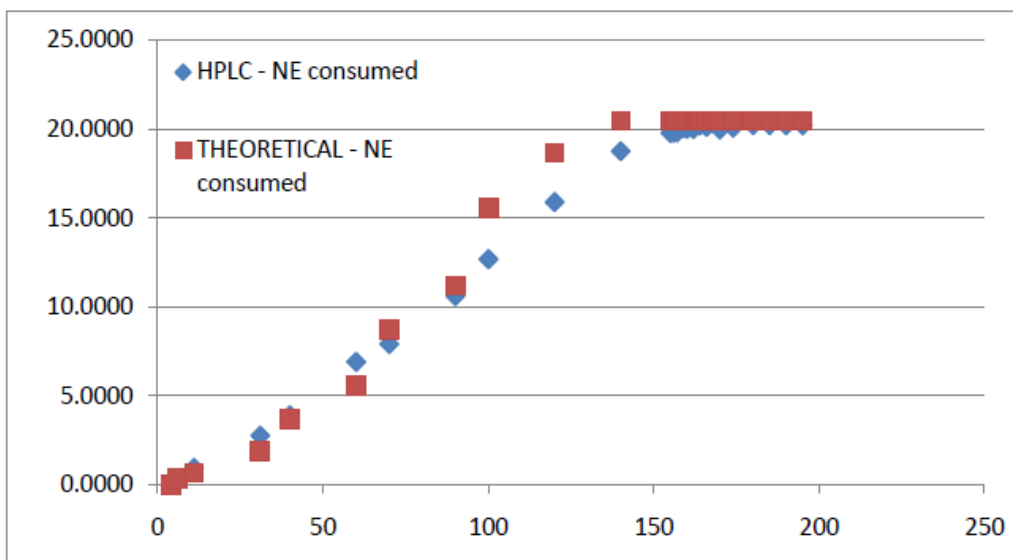
**Figure 17.** Process trend from Run 5 including current (left axis), pH (right axis), and ORP

The HPLC data from Run 5 was plotted and overlaid with the current and ORP data from the same run (Figure 18). Several observations can be made from this data. First, it is apparent that the rates of starting material consumption and product formation are relatively linear over the full range of applied currents. The catalyst concentration is also reasonably constant, suggesting that it remains stable in solution. The ORP slowly increases with time, as to be expected as the amount of starting material decreases (due to the increase in the amount of oxidized catalyst relative to reduced catalyst). Also, the

concentration of KDNE in solution never reaches the anticipated value, which was expected to be at least 0.36 M based on the INL bench-scale results. Finally, the rate of starting material (NE) consumption seems to be significantly faster than the rate of product (KDNE) formation. It would be expected that at least up until the time of product precipitation these rates would be roughly equivalent. A comparison of the theoretical amount of NE consumption (based on delivered charge) to the measured NE consumption (based on HPLC data) suggests that the charge efficiency based on NE depletion was quite good (Figure 19).



**Figure 18.** Process trend from Run 5 including NE, DNE and catalyst concentrations from HPLC (left axis), current (right axis), and ORP.



**Figure 19.** Charge efficiency based on NE consumed in Run 5. A comparison of the theoretical amount of NE consumption (based on delivered charge) to the measured NE consumption (based on HPLC data).

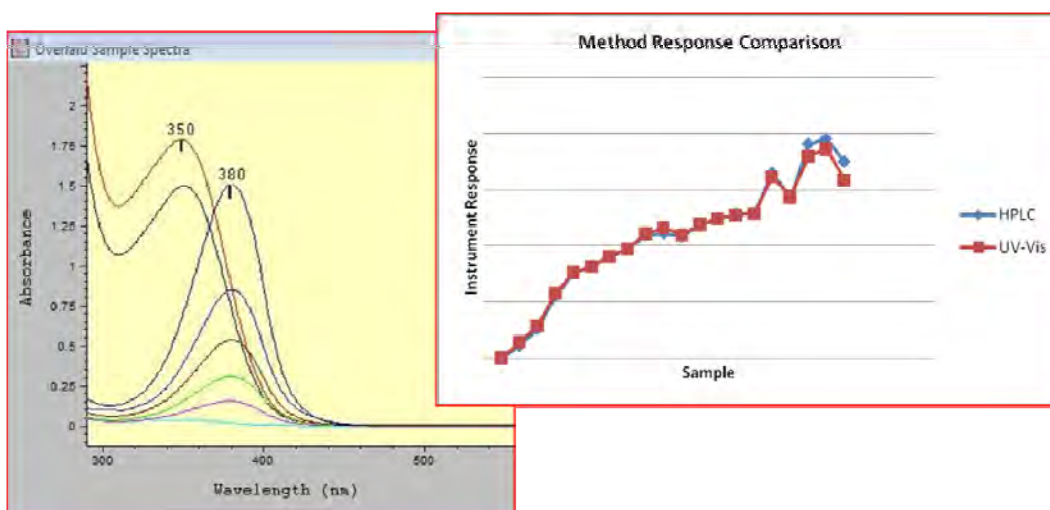
The KDNE from Run 5 was collected as a wet cake. Upon moisture analysis the amount collected corresponds to approximately 360 g of dry KDNE. If this is extrapolated to account for the amount of anolyte solution not sent to the crystallizer, this corresponds to a total of 540 g dry KDNE. The run was conducted for 200 minutes, so this amount corresponds to a rate of solid KDNE collection of approximately 0.36 lb/hour and a total collected KDNE yield of approximately 16.7%.

The results of Run 5 prompted an alteration of the equipment configuration such that a semi-continuous type crystallization scheme could be employed. In order to achieve this, a continuous loop was constructed between the anolyte vessel and the chilled crystallizer. This was viewed as an improvement in that material could be continuously precipitated out of the anolyte solution into the crystallizer, reducing the potential for the precipitation of product in unwanted areas of the system, such as the inlet to the cell where material might accumulate and plug the cell over time. It would also minimize the exposure of the product to the energy of the cell, which might otherwise lead to product decomposition over time. The modification was also more consistent with the program goal of increasing the production rate/hour, thereby decreasing overall labor costs associated with the product. In addition, the plan was to replenish the anolyte solution with NE at least 2-3 times based on ORP measurements, with the hope of reaching a “steady state” condition with respect to product formation/collection. The operation (Run 6) was to be conducted for 400 A for the entire run.

Run 6 commenced and the cell operated for approximately 90 minutes when an unplanned event occurred involving the anolyte solution preparation. In short, a 1 gallon Nalgene container with nitroethane/KOH solution developed pressure sufficient to rupture the container in the operating bay. There were no injuries or damage to personnel or equipment, but ATK safety protocols required that the run be prematurely halted until an investigation into the cause of the unplanned event could be determined. The cause of the pressure was determined to be due to heating developed by the acid/base reaction of nitroethane with potassium hydroxide solution, ultimately reaching the boiling/decomposition temperature of nitroethane. This undesired heat buildup was the consequence of inadequate agitation upon introduction of the NE to the basic aqueous solution which resulted in the formation of a biphasic system. Subsequently a technician noticed the two-layer system and shook the

container with cap tightly sealed, thereby allowing the heat and pressure buildup to take place. The vessel was standing alone on the floor, not in the technician's possession, when it ruptured. This was the first time that the technician had performed the procedure, and ultimately it was found that the planning was inadequate for a technician inexperienced in the specific operation to follow and that inadequate supervision was present. The necessary adjustments to the procedure were made and several internal ATK corrective actions based on "lessons learned" were imposed before operations continued on the program.

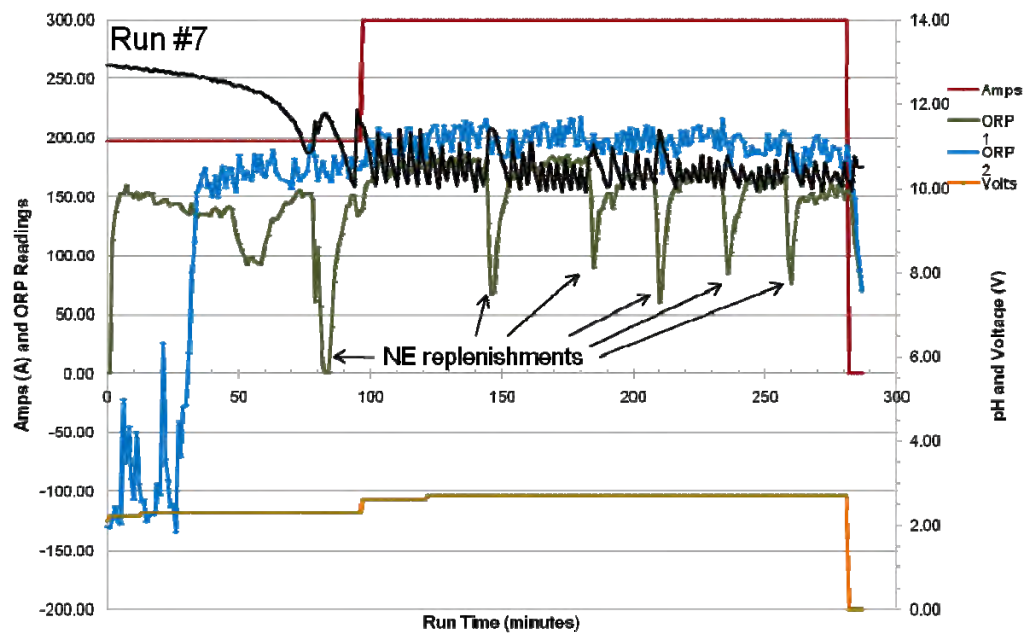
In the interim, several of the anolyte solutions collected during the course of Run 6 were analyzed by HPLC as well as ultraviolet-visible (UV-VIS) spectroscopy. Comparison of UV-VIS peak intensities with solution concentrations as determined by HPLC suggested that UV-VIS is promising method for offering real-time analysis of KDNE concentration (Figure 20). However, implementing such a method would require investment into a dedicated instrument and a dilution injection port and therefore was not realized. In the future this might be a valuable tool to indicate optimal replenish times and overall health of the anolyte.



**Figure 20.** Comparison of UV-VIS peak intensities with anolyte solution concentrations determined by HPLC. The consistency between both methods strongly suggests UV-VIS may be a valuable tool for real-time tracking of KDNE concentration.

The ensuing run identified as Run 7 was conducted in a manner similar to that planned for Run 6. The system configuration utilized the newly implemented side-loop crystallizer (semi-continuous mode). There was one in-line filtration device (at the outlet of anolyte vessel) through which the anolyte solution flowed to prevent solid KDNE from entering the EC cell. Prior to each replenishment operation the entire crystallizer contents were flushed and passed through the filter sock in order to collect the precipitated KDNE product. The plan was to replenish at minimum 4 times, optimally 5-6, in order to reach steady-state conditions, with the replenishments occurring *before* all of the NE starting material was depleted, with the goal of replenishing when 25-50% NE was depleted. This was meant to keep the system in a regime where the chemical reaction is proceeding faster than the EC reaction (to prevent buildup of oxidized catalyst, leading to undesired side reactions). The concentration of the base/NE solution was also lowered to 29% KOH, compared to 45.1% for Run 6, in order to reduce the likelihood of overheating which led to the aforementioned.

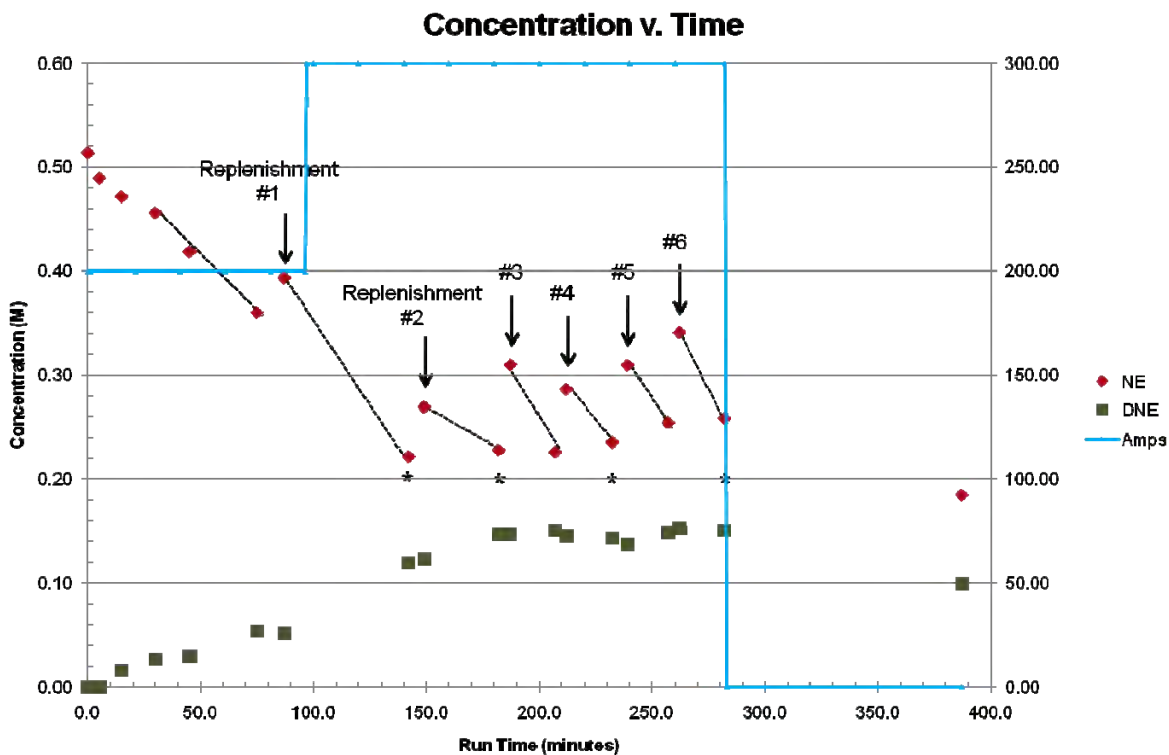
The initial analyte feed solution for Run 7 consisted of 2000 ml (28 mol) of NE, 2.3 kg (5.5 mol)  $K_4Fe(CN)_6$ , and 9.3 kg (109 mol) of  $KNO_2$  dissolved in DI water for a total solution volume of 12 gallons. The initial power supply to the cell was 200 A ( $\sim 2.3$  V), which was subsequently raised to 300 A after the first replenishment and remained constant at that current for the remainder of the run. In total, six replenishments were conducted, approximately every 25 minutes. The filter socks were removed after replenishments 1, 2, 4 and 6. The process trend for Run 7 is shown in Figure 21.



**Figure 21.** Process trend from Run 7.

The analyte solution from Run 7 was analyzed by HPLC. The HPLC data was plotted and overlaid onto the current profile from Run 7 (Figure 22). It is clear from this data that the rate of nitroethane depletion is fairly constant over the course of the entire run, independent of applied current and relatively independent of concentration within the examined range of 0.2 M - 0.6 M. As was seen in the batchwise process (Run 5), however, both the rate of formation of KDNE and the overall concentration of KDNE do not keep up with what would be expected based on the NE depletion rate. The KDNE concentration never appeared to rise above 0.15 M, well below the expected 0.36 M based on the INL bench-scale results.





**Figure 22.** Overlay of the NE and DNE concentrations determined by HPLC (left axis) and current profile from Run 7 (right axis). \*Denotes production collection points.

The total amounts of NE added to the anolyte solution, the amount of NE remaining after the reaction in the anolyte solution, and the amount of solid KDNE produced is shown in Table 9. The nitroethane added includes that contained in the initial feed solution as well as that added in the subsequent replenishments. The NE remaining after the run includes the NE in solution (that remaining in the anolyte) as well as that recovered in subsequent rinses of the EC cell with DI water. The difference provides the molar amount of NE consumed, which was 42.1 moles. The amount of solid KDNE produced and collected in each filter sock is also listed. The estimated rate of solid KDNE production throughout the run was approximately 925 g (2.1 lb) over the course of ~ 2.3 hours (once solution saturation was observed), which corresponds a production rate of approximately 0.91 lb/hour of solid (dry equivalent) KDNE.

**Table 9.** Amounts of starting NE, NE remaining after reaction, and solid KDNE produced in Run 7.

<u>Nitroethane Consumption:</u>				<u>Solid KDNE Production:</u>			
<b>Nitroethane Added</b>				<b>KDNE out</b>			
	Vol. (mL)	Mass (g)	moles	Filter	wet product	% moisture	dry product
Feed solution	2000	2090	27.8	1*	0.00	100.00	0.00
Replenishment	1860	1943.7	25.9	2*	0.00	100.00	0.00
<b>TOTAL IN</b>	<b>3860</b>	<b>4033.7</b>	<b>53.7</b>	<b>3</b>	<b>172.80</b>	<b>25.80</b>	<b>128.2</b>
				4	306.20	20.50	243.4
				5	280.04	25.20	209.4
				6	258.16	26.10	190.7
	Conc [M]	Volume (L)	moles	<b>TOTAL</b>	<b>1017.20</b>	<b>24.12</b>	<b>771.9 grams</b>
<b>NE in solution</b>	0.18	54.8825	9.9				<b>10.3 moles</b>
rinse 2	0.03	54.8825	1.6				
rinse 3	0.02	5.6775	0.1				
<b>NE consumed</b>			<b>42.1</b>	Correction factor for filter weigh procedure before vs. after filtration:			
				180	extra grams wet KDNE		
				2.4	extra moles KDNE		

**Table 10.** Mass balance for Run 7.

	Conc [M]	Volume (L)	moles
KDNE in solution	0.1	54.8825	5.5
Cell rinse 2	0.07	54.8825	3.8
Cell rinse 3	0.07	5.6775	0.4
Cell rinse 4	0.01	54.8825	0.6
<b>Total KDNE in solution</b>			<b>10.3 moles</b>
Collected Solid KDNE			12.7 moles
<b>TOTAL KDNE Accounted for:</b>			<b>23.0 moles</b>
Total NE consumed:			42.1 moles
<b>KDNE total yield from NE:</b>			<b>55%</b>

Consideration of the mass balance shows that improvements still need to be made with regard to efficiency and yield of the reaction (Table 10). When all produced KDNE (collected solid + remaining in anolyte solution + collected in rinse water) is compared to all of the nitroethane consumed (NE added – (remaining in anolyte + remaining in rinse water)) one can see that the yield of KDNE produced is approximately 55% based on the NE consumed. One possible explanation for this disparity would be over-oxidation of the NE product. However, no unidentified peaks from organic materials were identified in any of the analytical tests performed on the anolyte solution. These tests included HPLC, GC, FT-IR, UV-Vis, and ion chromatography. Oxidation to gaseous products might lead to the escape of organics from the system in gaseous form, but this does not seem likely, as the anolyte loop was a closed system vented to the atmosphere only through a simple oil bubbler located at the inlet to the anolyte tank; at no time was significant bubbling observed at this location. Discussion with the cell

manufacturer led to the hypothesis that perhaps product had become trapped within the carbon-felt matrix of the anode within the cell itself. However, disassembly of the cell did not reveal any additional product. At this point, it is still unclear why the molar amount KDNE produced is only about half the molar equivalents of nitroethane added. The answer would have to be ascertained through further exploration of the problem through expanded chemical analysis of the anolyte solution over time.

### 5.2.2 Optimization of the Conversion of KDNE to DNPOH

An additional task on this program was to use the KDNE obtained from the EC synthesis to optimize the reaction conditions for the conversion of KDNE to DNPOH. This work was conducted in the laboratory using KDNE product from Run 7. A matrix of eight different reactions, varying three parameters was devised. The variables were temperature, concentration in H<sub>2</sub>O and molar equivalents of formaldehyde added. The corresponding reactions were carried out and the yield and product purity of each reaction were measured by both GC and HPLC. In each reaction, the KDNE was dissolved into distilled water and adjusted to pH 10-11 with 5% KOH solution. The desired number of equivalents of 37% formaldehyde solution (aqueous) was added with stirring. The reactions were stirred for approximately one hour at temperature, the product was extracted with EtOAc and isolated *in vacuo*. The results are shown in Table 11. Although not completely conclusive based due to the limited number of experiments evaluated, the results indicated that the reaction is relatively tolerant of the range of variables explored. The best conditions based on yield and percent impurities appears to be experiment # 5 (Table 11): 1.2 molar equivalents of formaldehyde per mole of KDNE, higher dilution in water (HW = 14 weight equivalents of H<sub>2</sub>O per equivalent of KDNE), and higher temperature (HT = 50 °C). This information provides guidelines for a path forward to further optimize this reaction at the pilot/production scale.

**Table 11.** Results of the laboratory optimization study for the conversion of KDNE to DNPOH.

Reaction #	Conditions	% Yield (GC)	Impurity (HPLC)
1	LF/LW/LT	94.5	1.5
2	LF/HW/LT	91.4	0.8
3	LF/LW/HT	84.4	1.1
4	HF/LW/LT	88.0	2.3
5	LF/HW/HT	97.3	0.4
6	HF/HW/LT	91.4	1.5
7	HF/LW/HT	96.0	2.3
8	HF/HW/HT	85.9	0.8

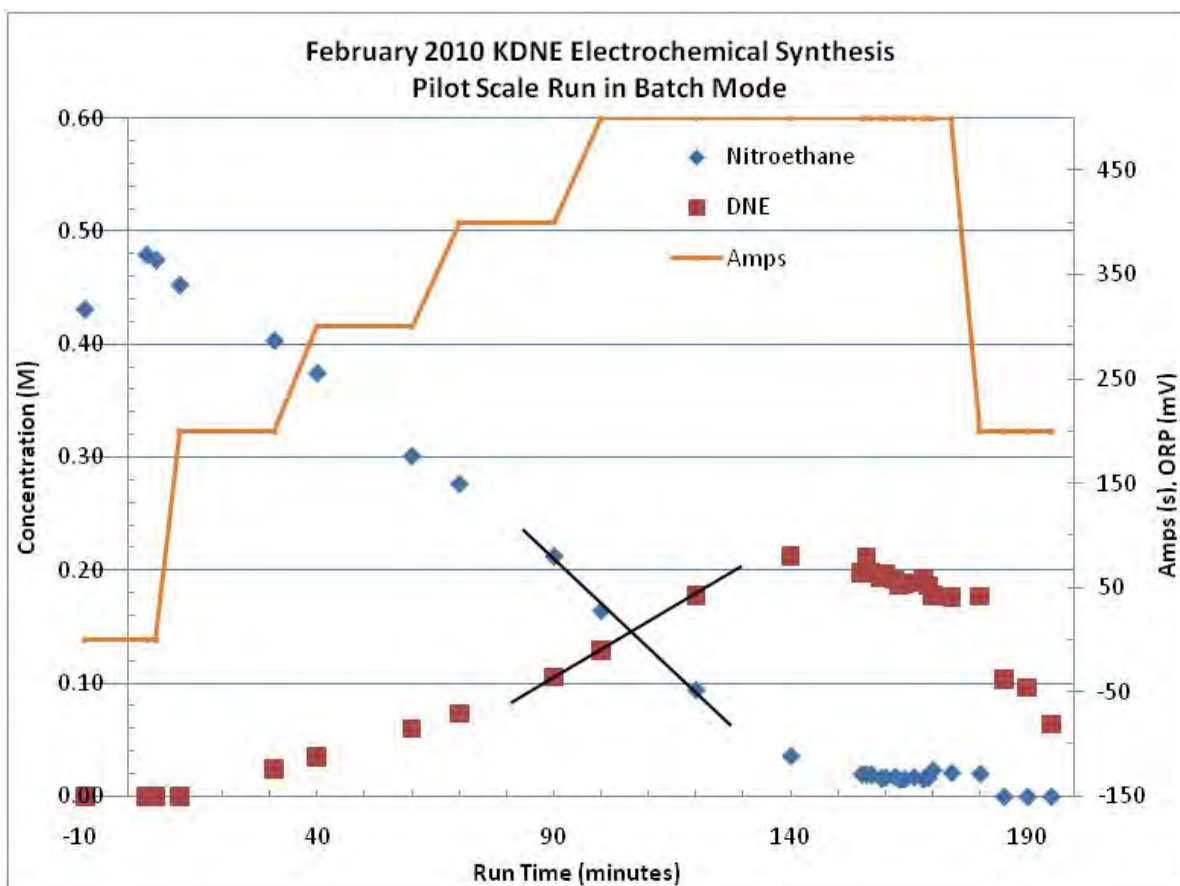
LF = 1.2eq formaldehyde / eq. KDNE, HF = 1.8eq. formaldehyde / eq. KDNE  
 LW = 10 wt eq H<sub>2</sub>O / eq. KDNE, HW = 14 wt eq H<sub>2</sub>O / eq. KDNE  
 LT = 25 °C, HT = 50 °C

## 6.0 PROCESS SCALABILITY ASSESSMENT

The pilot scale experiments provided enough information to develop a conceptual model for a large scale production facility. For the purpose of this assessment, it was assumed that a 10,000 lb of A/F per year market demand exists. Consideration was also given to potential market growth to 100,000 lb of A/F per year. The goal of the scalability assessment was to identify the potential cost advantages of A/F production via an EC route taking into account amortized equipment capital costs. To identify the cost breaks, detailed specification of equipment, and an accurate understanding of labor to support processes was needed. A detailed cost analysis is premature at the current state of development, based on the maturity of the process and understanding of the operating conditions. A less formal treatment is presented here, comparing raw material costs and waste streams generated by the proposed and legacy processes. In addition, the type of equipment required by the scaled up EC process is specified and roughly scaled.

### 6.1 Estimate of In-Production Reaction Yields

Estimating EC process yields in production is key to accurately scaling the process. As demonstrated in the pilot scale, anolyte reactants (i.e. NE,  $\text{KNO}_2$ ) can be replenished as they are consumed, providing for continuous operation. Though the starting concentrations of reactants were not sustained during the pilot scale experiment run in continuous mode, it is certain that a replenishment rate will be determined to hold the reactant concentrations at steady state. The best observed instantaneous yield from preliminary pilot scale experiments is assumed to be achievable in continuous operation. From batch experiments in February 2010, at 400 A, and greater, an instantaneous reaction yield of 62% (on a molar basis conversion of NE to KDNE) was achieved as shown in the Figure 23. It is reasonable to believe that this yield is sustainable in a continuous mode, though this has yet to be demonstrated at the pilot scale. For the brief period of time where this conversion was obtained (30 minute duration), the production rate of KDNE was 2.77 lb/hr.



**Figure 23.** Evaluation of highest instantaneous yield from pilot scale experiments. The equations for the linear trend lines are  $y = 2.396E-03x - 1.102E-01$  and  $y = -3.883E-03x + 5.585E-01$  for the instantaneous KDNE production and NE consumption rates respectively, providing an instantaneous KDNE yield of 62%.

## 6.2 Basis of Assessment

It is necessary to identify the target production capacity in order to accurately specify the process equipment. The current market demand for A/F is estimated to be 10,000 lb per yr. The government has historically been comfortable procuring 100,000 lb of A/F at a time, as it can be stored without degradation for many years. Therefore, the design space for production capacity is bound between 10,000 and 100,000 lb A/F per year. Production cost per pound of A/F by the legacy process was found to range by 40% between the two scales of production above. A tradeoff exists between low labor and high production rates and startup capital costs determined by equipment sizing. The annual A/F production rate of 10,000 lb per year can be produced, for example, over the course of a calendar year, or in a month (the approximate production duration of the legacy process). For the purposes of this preliminary assessment, it is assumed that the instantaneous production rate of the new process should be commensurate with the legacy process, to maintain similar process labor costs. This scaling assessment not only considers a plant optimized for producing 10,000 lb of A/F per month, but is also capable of running year-round to produce 100,000 lb of A/F annually.

The EC synthesis of KDNE followed by chemical conversion to DNPOH replaces the legacy synthesis of DNPOH, while processes to convert DNPOH to A/F are assumed to remain the same. An A/F annual production capacity of 100,000 lb/yr, with a standard 20% annual downtime, is capable of an instantaneous production rate of 120,000 lb of A/F/year. Molar yields from the legacy processes are

53.5% for conversion of DNPOH to BDNPA, and 66.3% for conversion of DNPOH to BDNPA/F, for an average yield of 60% from DNPOH. Therefore, the target annual production rate is 95,000 lb DNPOH per year, and 103,000 lb of KDNE per year. The plant then is optimized to produce 10,000 lb batches of A/F, but is also capable of producing up to 100,000 A/F a year.

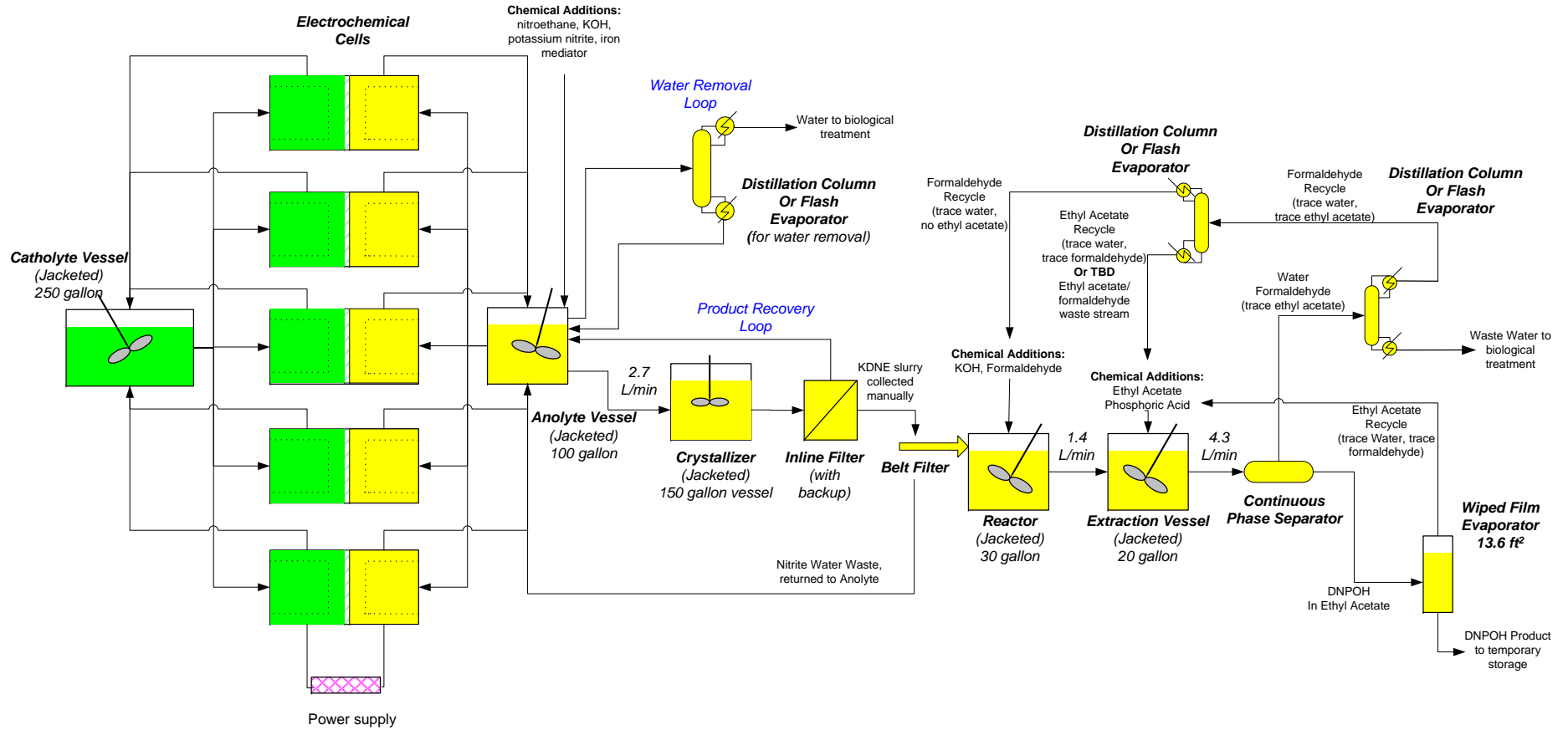
### **6.3 Scaling of the EC Cell**

The EC cell can be scaled to a larger cell, or multiple cells can be run in parallel, or a combination of these two approaches. The dimensions of the EC cell used at the pilot scale were found to be practical from a handling and cleaning perspective. It is assumed that a bank of cells, identical to the cell used in pilot scale experiments, could be used in production. Further study of cell size and reaction efficiency is recommended, as well as a cost trade analysis between cell size and quantity. In the event that market demand increases, modular additions could be made to the cell bank and to downstream processing equipment.

The instantaneous production rate of 103,000 lb of KDNE per year, produced with similar sized cells as the pilot scale cell, would require a bank of 5 cells (4.3 cells rounded up) in parallel. Figure 24 shows the unit operations flow diagram depicting a general overview of the DNPOH production process. For lack of better information, it is assumed that the catholyte and anolyte volume should scale linearly from the pilot scale to production. Two hundred seventy-five liters of anolyte and 750 L of catholyte would therefore support the 5 cells. It is possible that the catholyte and anolyte volumes could be reduced, though further study of the effect of changing volume is warranted.



**Synthesis of DNPOH via  
Electrochemical Synthesis of KDNE  
Unit Operations At Full Scale Production**



**Figure 24.** Proposed unit operations for production scale synthesis of DNPOH via EC synthesis of KDNE.



#### 6.4 Continuous Removal of Byproduct Water

Running as a continuous process, the reactant concentrations must be maintained considering that water is produced as a byproduct of the nitration of nitroethane. In the batch configuration, the produced water acts to continuously dilute the anodic solution, thus requiring continuous addition of reactants in excess of the amount consumed. Additionally, KOH and  $K_4Fe(CN)_6$  must be added to maintain targeted anolyte concentrations. As performed at the pilot scale, these additions would lead to an ever increasing solution volume, and effectively generate an additional waste stream containing difficult to remove nitrite salt. While water generation was not tracked in pilot scale experiments, the assumption is made that a mole of  $H_2O$  is generated for every mole of NE consumed, resulting in a generation rate of approximately 1 L of  $H_2O$  per hour.

A process is required that removes the byproduct water, without removing or degrading the reactants. One potential solution is to remove the water by distillation or flash evaporation. The effect of heating the mixture on the reactants is unknown and would have to be investigated, as would recovery rates, though the boiling point and vapor pressure difference would suggest that the water is readily separable. Vacuum distillation should be considered, to minimize heating of the reactants. A continuous bypass of reactant solution would be passed through distillation equipment. A chiller would be necessary to return the anolyte solution to the desired reaction temperature. Due to the relatively small quantity of water that would be removed, a traditional distillation column may not be necessary, and instead a single stage flash evaporator may suffice; though nitroethane concentrations in the distilled water would likely be higher than could be achieved with multistage distillation. A price trade analysis between capital cost and raw material savings from greater nitroethane recovery will require an assessment of recovery of designed evaporators. Condensed distillate water, contaminated with small amounts of nitroethane is readily treatable by a biological wastewater treatment plant (such as that at ATK) at negligible cost.

#### 6.5 Continuous Precipitation of KDNE

Continuous removal of KDNE product is necessary to prevent saturation of the anolyte solution and precipitation in the cell. With limited success, continuous crystallization of KDNE was demonstrated at the pilot scale, despite the fact that the crystallization vessel was designed specifically for batch operation. Shocking cooling the anolyte solution to temperatures far below its saturation temperature is not under consideration due to the likelihood of precipitating small, difficult to filter, particles, and the increased potential to trap contaminants in the crystals. The crystallization vessel should be designed for the necessary residence time to promote crystal growth to filterable particle size distributions. For the purpose of this preliminary assessment, no improvements to the crystallization process are implemented during scale-up, and the 2.5 hour crystallization residence time demonstrated at the pilot scale is adequate to achieve the desired particle size distribution. Continuous removal of KDNE in production should be designed to prevent KDNE precipitation in the EC cell. The saturation temperature of KDNE in the anolyte solution is high enough that precipitation can occur in the cell during at ambient conditions. Continuous crystallization was performed at pilot scale, but with concern that precipitation could occur past the inline filters, in the EC cell. Precipitation concerns are remedied by controlling the temperature of the anolyte vessel, and continuously removing only a fraction of the anolyte solution for crystallization. In the pilot scale process, inline filters were used to remove precipitated KDNE and are considered the ideal method for filtration at production scale. A parallel backup filter is required to support continuous production. Settling basins have been considered, and could feasibly settle particles, but would require very large anolyte volumes to enable residence times necessary for settling, and still require significant labor support to remove KDNE precipitate.

In order to maintain a steady state concentration in the anolyte, KDNE must be removed at the same rate it is produced. The ideal concentration of KDNE in the anolyte is 0.2 M based on pilot scale runs (maximum concentration achieved at max production rate with negligible signs of product degradation). At this

concentration, and the given KDNE production rate, approximately 2.8 L of anolyte per minute must be diverted to the crystallization process at a steady state. Complete crystallization of KDNE in the crystallizer and return of KDNE-free solution to the anolyte vessel is assumed as a rough approximation. A 2.5 hour residence time, with a feed of 2.8 L of anolyte per minute indicates that a 420 L crystallization vessel is required. The total system volume of anolyte is roughly 750 L which is the sum of the volumes of the cell, anolyte vessel, crystallizer (20 L), piping, and inline filter (1" diameter, 200 ft).

Ideally, processes downstream of KDNE precipitation will generate water waste streams with no nitrite salts, to avoid salt removal processes that make waste water treatment costly. The wet KDNE recovered from the inline filter will be dried on a belt filter prior to further reaction, in order to remove residual anolyte solution containing nitrite salts. Residual anolyte solution will be returned to the anolyte vessel. It is assumed that the residual concentration of nitrite salts in the KDNE will be low enough to avoid special treatment of wastewater in the subsequent processes.

### **6.6 Scale-up of DNPOH from KDNE**

The conversion of KDNE to DNPOH was demonstrated in the laboratory, and could readily be scaled up with common processing equipment. The laboratory process has not been scaled up to the pilot facility, and therefore has not been optimized for efficient low cost production. Excess volumes of formaldehyde, ethyl acetate, and phosphoric acid are used. Yield as a function of reaction time has not been evaluated. Regardless, the lab scale data is the best information available, and serves as a worst case assessment from the standpoint of equipment sizing and waste stream generation. It remains to be determined if the DNPOH synthesis is most efficiently run as a continuous or batch process. In practice, the synthesis could initially be run as a batch process, and later the process could be improved by incorporating KDNE solids feeding and conversion to a continuous process. For the purposes of this assessment, the process is assumed to run continuously.

Preliminary laboratory scale experiments suggest that the highest batch yield of DNPOH (97% yield) was achieved at elevated temperature (50 °C), thus requiring a heated mixing vessel for the formalation of KDNE. A second mixing vessel would be required for extraction with ethyl acetate, followed by a continuous phase separator. In the laboratory, the ethyl acetate was separated from the product under reduced pressure. This could be duplicated at the production scale, removing the bulk of the ethyl acetate by vacuum, collecting the vapor and recycling the solvent. A wiped film evaporator has historically been used to remove process solvent from DNPOH.

The scale of the formalation reactor is determined by the residence time required for reaction and the flow rate through the reactor. A reaction time of one hour was practiced at the lab scale to ensure sufficient time for reaction completion. The following quantities of materials were used in the formylation reaction: 0.5 g KDNE, 7 g H<sub>2</sub>O, 0.3 g formaldehyde solution (37% aq), and a negligible amount of 5% KOH solution. Scaled to production rates, total volumetric flow rate through the formylation reactor is approximately 1.4 L/min. To achieve an average residence time of one hour, a reaction volume of 22 L is required.

Prior to DNPOH extraction with ethyl acetate, the potassium salt solution is acidified with phosphoric acid. In production, it is assumed that extraction and acidification can be performed in the same mixing vessel. The required wash time for this operation to optimally extract DNPOH is not known from laboratory data, but is expected to be a relatively fast process. Typically with other synthesis processes, wash operations of 15 minutes are considered more than adequate. Based on the volumes of phosphoric acid (1.5 mL) and ethyl acetate (15 mL) used in the lab, the expected volumetric flowrate through the production extraction mixing vessel is 4.3 L per minute, requiring a reaction volume of 17 L.

Based on the excellent separation encountered at the laboratory scale, it is expected that a continuous liquid-liquid phase separator will successfully separate the liquids from the extraction vessel into an organic (ethyl acetate) stream rich in DNPOH, and an aqueous stream rich in formaldehyde. In theory, the excess formaldehyde can be recovered from the aqueous stream prior to disposal. The difficulty of separating formaldehyde from water must be investigated further to determine the optimal method. If formaldehyde recovery is not pursued, small amounts of formaldehyde can be handled by biological wastewater treatment.

Wiped film evaporation is used in the legacy A/F process to recover ethyl acetate from DNPOH. DNPOH is a waxy solid that has a melting point near room temperature, making it difficult to recover as a slurry in a continuous production system. A 13.6 ft<sup>2</sup> wiped film evaporator (such as that currently at ATK) is capable of supporting production of 75 lb of DNPOH per hour, and is therefore sufficient for the lower instantaneous production rate of the process proposed herein. It is proposed that ethyl acetate recovered by the wiped film evaporator be recycled to the KDNE to DNPOH process. The ethyl acetate may have small quantities of both water and formaldehyde returned without affecting the extraction process. The ethyl acetate stream may be returned directly from the wiped film evaporator to the extraction process without further processing.

### **6.7 Raw Material Costs in Production**

The raw materials costs to produce KDNE in support of a 10,000 lb A/F production campaign are summarized in Table 12. It is assumed that anolyte and catholyte solutions are not stable and are disposed of at end of the campaign, though this material only comprises 3% of the total material costs at this scale of production. Raw material costs to convert KDNE to DNPOH are calculated based on low maturity laboratory data, and with further study can likely be optimized for more efficient production. Complete recycle of formaldehyde and ethyl acetate is assumed, though further study of losses during extraction and subsequent separations should be investigated. Losses are expected to be negligible relative to consumed material costs. Cost of process water is negligible. Raw material costs to produce DNPOH are estimated to be roughly \$4.10 per pound of A/F produced. Cost estimates performed in 2002 by ATK place the raw material costs to produce DNPOH via the legacy process at roughly \$8.40 per pound of A/F produced. The cost of conversion of DNPOH to A/F remains the same as the legacy process, the raw material costs of which were estimated in 2002 to be \$9.30 per pound A/F. Therefore, the raw material cost of the proposed EC process is estimated to be \$13.4 per pound of A/F, down approximately \$4.30 from \$17.7 per pound A/F by the legacy process.

**Table 12.** Raw materials consumed by proposed production scale process.

<b>Raw Materials Consumed in the Synthesis of 8,600 lb of KDNE and 7,900 lb of DNPOH in Support of Production of 10,000 lb A/F</b>				
<b>Raw Material</b>	<b>Method of Consumption</b>	<b>lb</b>	<b>Unit Cost (\$/lb)</b>	<b>Cost (\$)</b>
Nitroethane	Continuous Reaction	6514	2.55	16770
	End of Run Anolyte Disposal	62		
Potassium Ferricyanide	End of Run Anolyte Disposal	87	2.65	231
Potassium Hydroxide	End of Run Anolyte Disposal	111	0.15	176
	End of Run Catholyte Disposal	1076		
Potassium Nitrite	Continuous Reaction	7385	0.19	1416
	End of Run Anolyte Disposal	68		
Formaldehyde 37%	Continuous Reaction	4367	0.38	1659
Phosphoric Acid	Not Recycled	48427	0.42	20339
<b>Total KDNE Raw Material Cost</b>				<b>40591</b>
<b>KDNE Raw Material Cost per lb A/F</b>				<b>4.06</b>

### 6.8 Waste Streams Generated by Production Process

The waste streams generated by the EC KDNE and DNPOH processes based on production of 10,000 lb of A/F are summarized in Table 13. Wastes laden with nitrites and sulfates dominated the cost of waste disposal in the legacy KDNE and DNPOH processes. By comparison, the proposed process generates an insignificant quantity of nitrite waste. It is possible that the anolyte solution could be recovered, stored, and reused in later campaigns. The long term stability of the solutions is not known, and should be investigated further. For the purposes of waste disposal cost estimation, no anolyte reuse is assumed. The DNPOH process yields a significant amount of water waste, but this waste is expected to be nitrite-free, and readily processed by a biological waste treatment plant at negligible cost. The water waste, based on laboratory data, may be reduced as this process is scaled to production. In comparison, the legacy process produces approximately 860,000 lb of aqueous nitrate and sulfate laden waste per 10,000 lb of A/F produced. In conclusion, it is estimated that conversion to the proposed KDNE and DNPOH process will reduce raw material costs by as much as 25%. Additionally, waste streams containing nitrite salt contaminants are nearly eliminated by the EC process, significantly reducing waste disposal costs.

**Table 13.** Waste stream assessment for proposed EC process.

<b>DNPOH Waste Streams via EC Synthesis of KDNE</b>					
<b>Waste</b>	<b>Source of Waste Stream</b>	<b>Pounds KDNE Synthesis Waste per 10,000 lb Batch of A/F</b>	<b>Biological Treatment</b>	<b>Contains Nitrite Salts Requiring Removal and Off-Plant Disposal</b>	<b>Solvents Requiring Off-Plant Disposal</b>
Water	Byproduct from EC Reaction	1,600	Yes	No	No
	Process Water from Formaldehyde Reactor	123,200	Yes	No	No
Catholyte Solution	End of Campaign Disposal	1,800	Yes	No	No
Anolyte Solution	End of Campaign Disposal	1,800	Yes	Yes	No
Ethyl Acetate/Formaldehyde	Separated from Formaldehyde Recycle	TBD	No	No	Yes

## 7.0 CONCLUSIONS AND IMPLICATIONS FOR FUTURE RESEARCH/IMPLEMENTATION

The bench-scale process for the EC production of KDNE has been successfully demonstrated on the pilot-scale at ATK Launch Systems. Through a collaborative effort with Idaho National Laboratory and Electrochemistry, Inc., the pilot-scale set-up was designed and built in the M-346 energetic materials synthesis facility at ATK. The production of high-purity KDNE was realized at the rate of 1 lb per hour of cell operation. The KDNE was then converted in the lab to high-purity DNPOH by treatment with formaldehyde and phosphoric acid. A competitive cost based analysis of the EC process compared to the traditional chemical synthesis proved that there are substantial savings in the EC route, both in material and disposal expenditures. Stability of multiple solution phase equilibria in the anolyte was the most challenging aspect of this project and is a topic that warrants additional investigation. Nonetheless, these results are extremely promising and with further optimization it is envisioned that this research will lead the way to an economically and environmentally sound route for the production of DNPOH and ultimately BDNPA/F. Finally, it is likely that this process can be used for the EC synthesis of an array of other explosive compounds that are classically produced by oxidative nitration reactions.

## APPENDIX A

### PROJECT PARTICIPANTS

- **ATK Launch Systems:** Principal research organization. Responsible for program management and operation of pilot-scale KDNE process.

Alexander Paraskos: [alex.paraskos@atk.com](mailto:alex.paraskos@atk.com)

Marvin Hawkins: [marvin.hawkins@atk.com](mailto:marvin.hawkins@atk.com)

- **Idaho National Labs:** Provide support and advise based on lab-scale electrochemistry when issues arise that can best be addressed through bench-scale experiments

Tedd Lister: [Tedd.Lister@inl.gov](mailto:Tedd.Lister@inl.gov)

Robert Fox: [Robert.Fox@inl.gov](mailto:Robert.Fox@inl.gov)

- **Electrosynthesis Inc:** Provided assistance and direction with use of pilot-scale EC cell and maintenance, as well as assistance with potential scale-up estimates with regard to production-scale EC cells and operation.

Peter Symons: [info@electrosynthesis.com](mailto:info@electrosynthesis.com)