



**AFRL-RX-WP-TR-2011-4322**

**MANUFACTURING TECHNOLOGY SUPPORT (MATES)  
Task Order 0021: Air Force Technology and Industrial Base Research  
and Analysis, Subtask Order 06: Direct Digital Manufacturing**

**Kevin Hartke**

**Mound Laser & Photonics Center, Inc.**

**AUGUST 2011  
Final Report**

**Approved for public release; distribution unlimited.**

*See additional restrictions described on inside pages*

**STINFO COPY**

**AIR FORCE RESEARCH LABORATORY  
MATERIALS AND MANUFACTURING DIRECTORATE  
WRIGHT-PATTERSON AIR FORCE BASE, OH 45433-7750  
AIR FORCE MATERIEL COMMAND  
UNITED STATES AIR FORCE**

## NOTICE AND SIGNATURE PAGE

Using Government drawings, specifications, or other data included in this document for any purpose other than Government procurement does not in any way obligate the U.S. Government. The fact that the Government formulated or supplied the drawings, specifications, or other data does not license the holder or any other person or corporation; or convey any rights or permission to manufacture, use, or sell any patented invention that may relate to them.

This report was cleared for public release by the USAF 88th Air Base Wing (88 ABW) Public Affairs Office (AFRL/PAO) and is available to the general public, including foreign nationals. Copies may be obtained from the Defense Technical Information Center (DTIC) (<http://www.dtic.mil>).

AFRL-RX-WP-TR-2011-4322 HAS BEEN REVIEWED AND IS APPROVED FOR PUBLICATION IN ACCORDANCE WITH THE ASSIGNED DISTRIBUTION STATEMENT.

\*//Signature//

---

STEPHEN L. SZARUGA, Chief Engineer  
Manufacturing & Technology Division  
Materials and Manufacturing Directorate

//Signature//

---

PERSIS A. ELWOOD, Division Chief  
Manufacturing & Technology Division  
Materials and Manufacturing Directorate

This report is published in the interest of scientific and technical information exchange, and its publication does not constitute the Government's approval or disapproval of its ideas or findings.

\*Disseminated copies will show “//Signature//” stamped or typed above the signature blocks.

# REPORT DOCUMENTATION PAGE

*Form Approved*  
OMB No. 0704-0188

The public reporting burden for this collection of information is estimated to average 1 hour per response, including the time for reviewing instructions, searching existing data sources, gathering and maintaining the data needed, and completing and reviewing the collection of information. Send comments regarding this burden estimate or any other aspect of this collection of information, including suggestions for reducing this burden, to Department of Defense, Washington Headquarters Services, Directorate for Information Operations and Reports (0704-0188), 1215 Jefferson Davis Highway, Suite 1204, Arlington, VA 22202-4302. Respondents should be aware that notwithstanding any other provision of law, no person shall be subject to any penalty for failing to comply with a collection of information if it does not display a currently valid OMB control number. **PLEASE DO NOT RETURN YOUR FORM TO THE ABOVE ADDRESS.**

<b>1. REPORT DATE (DD-MM-YY)</b> August 2011		<b>2. REPORT TYPE</b> Final		<b>3. DATES COVERED (From - To)</b> 19 October 2010 – 28 June 2011	
<b>4. TITLE AND SUBTITLE</b> MANUFACTURING TECHNOLOGY SUPPORT (MATES) Task Order 0021: Air Force Technology and Industrial Base Research and Analysis, Subtask Order 06: Direct Digital Manufacturing				<b>5a. CONTRACT NUMBER</b> FA8650-04-D-5711-0021-06	
				<b>5b. GRANT NUMBER</b>	
				<b>5c. PROGRAM ELEMENT NUMBER</b> 78011F	
<b>6. AUTHOR(S)</b> Kevin Hartke				<b>5d. PROJECT NUMBER</b> J0M505	
				<b>5e. TASK NUMBER</b> 00	
				<b>5f. WORK UNIT NUMBER</b> M0120400	
<b>7. PERFORMING ORGANIZATION NAME(S) AND ADDRESS(ES)</b> <b>By:</b> Mound Laser & Photonics Center, Inc. P.O. Box 223 Miamisburg, OH 45343-0223				<b>For:</b> Universal Technology Corporation 1270 North Fairfield Road Dayton, OH 45426-2600	
<b>9. SPONSORING/MONITORING AGENCY NAME(S) AND ADDRESS(ES)</b> Air Force Research Laboratory Materials and Manufacturing Directorate Wright-Patterson Air Force Base, OH 45433-7750 Air Force Materiel Command United States Air Force				<b>8. PERFORMING ORGANIZATION</b>  REPORT NUMBER	
				<b>10. SPONSORING/MONITORING AGENCY ACRONYM(S)</b> AFRL/RXM	
<b>11. SPONSORING/MONITORING AGENCY REPORT NUMBER(S)</b> AFRL-RX-WP-TR-2011-4322					
<b>12. DISTRIBUTION/AVAILABILITY STATEMENT</b> Approved for public release; distribution unlimited.					
<b>13. SUPPLEMENTARY NOTES</b> PAO Case Number: 88ABW 2011-5626; Clearance Date: 20 Oct 2011. Report contains color.					
<b>14. ABSTRACT</b> The project included a review of the Direct Digital Manufacturing industry, which included additive, subtractive, and hybrid manufacturing. The review also included reverse engineering, part information data storage, diagnostics, and CAD/CAM technologies. There was a significant amount of information gained on all of the above technologies. The key area of development for this industry is advancing additive manufacturing technology. This area of the Direct Digital Manufacturing industry provides the most promise on direct part fabrication but also requires additional development in materials qualification, machine to machine consistency, inline processing monitoring, increased deposition rates, and improve part surface finish.					
<b>15. SUBJECT TERMS</b> subcontract, final report, direct digital manufacturing					
<b>16. SECURITY CLASSIFICATION OF:</b>			<b>17. LIMITATION OF ABSTRACT:</b> SAR	<b>18. NUMBER OF PAGES</b> 104	<b>19a. NAME OF RESPONSIBLE PERSON (Monitor)</b> Stephen L. Szaruga
<b>a. REPORT</b> Unclassified	<b>b. ABSTRACT</b> Unclassified	<b>c. THIS PAGE</b> Unclassified			

# TABLE OF CONTENTS

<u>Section</u>	<u>Page</u>
LIST OF FIGURES .....	iii
1.0 SUMMARY .....	1
2.0 BACKGROUND ON DIRECT DIGITAL MANUFACTURING .....	3
3.0 DATA COLLECTION METHODOLOGY .....	4
4.0 FINDINGS AND DISCUSSION.....	5
4.1 Additive Manufacturing.....	5
4.1.1 Direct Metal Laser Sintering.....	5
4.1.2 Direct Metal Deposition.....	6
4.1.3 Electron Beam Melting.....	8
4.1.4 Electron Beam Free Form Fabrication.....	9
4.1.5 Summary of Additive Beam Based Processes .....	10
4.1.6 Selective Laser Sintering .....	12
4.1.7 Stereolithography .....	13
4.1.8 Fused Deposition Modeling.....	14
4.1.9 3D Ink-Jet Printing.....	14
4.1.10 Additive Manufacturing Summary .....	15
4.2 Subtractive Manufacturing.....	17
4.2.1 CNC Machining .....	17
4.2.2 Waterjet Machining .....	18
4.2.3 Laser Micromachining.....	18
4.2.4 Subtractive Manufacturing Conclusions.....	19
4.3 Hybrid Manufacturing .....	19
4.3.1 Ultrasonic Consolidation .....	20
4.3.2 Direct Write Electronics .....	20
4.3.3 Additive/Subtractive Manufacturing Technologies.....	21
4.3.4 Multi-Material Processing .....	21
4.4 Part Information Data Storage .....	22
4.4.1 Types of Information to Store.....	22
4.4.2 GUID.....	23
4.4.3 Alphanumeric Marking.....	24

4.4.4	2D Bar Codes .....	26
4.4.5	RFID .....	27
4.5	Reverse Engineering .....	27
4.5.1	Coordinate-Measuring Machines .....	27
4.5.2	Portable 3D Scanning .....	28
4.5.3	Laser Scanning.....	29
4.5.4	Computer Tomography (CT) X-Ray Scanning.....	30
4.5.5	Industrial Computed Tomography X-Ray Scanning .....	31
4.6	CAD/CAM Technologies .....	31
4.7	Diagnostics.....	33
5.0	CONCLUSIONS.....	35
6.0	REFERENCES .....	38
APPENDIX A		
	Direct Digital Manufacturing Survey .....	39
APPENDIX B		
	Book Summary .....	45
APPENDIX C		
	Additive Manufacturing Workshop – Wright State University.....	49
APPENDIX D		
	EWI Additive Manufacturing Consortium Meeting.....	58
APPENDIX E		
	LAM.....	60
APPENDIX F		
	IBIC Report.....	69
LIST OF SYMBOLS, ABBREVIATIONS AND ACRONYMS.....		93

## LIST OF FIGURES

<b><u>Figure</u></b>	<b><u>Page</u></b>
1. Direct Digital Manufacturing.....	3
2. Direct Digital Manufacturing Upstream and Downstream Process.....	3
3. Decision Tree.....	4
4. Examples of Components Fabricated Using DMLS (www.electroptics.com, www.eos.info) .....	5
5. Decision Tree for DMLS .....	5
6. Laser Engineering Net Shaping (LENS) in Process (www.sandia.gov).....	6
7. Decision Tree for DMD .....	7
8. POM DMD System Combined with Subtractive Femtosecond Laser Processing .....	7
9. BLISK DMD Fabrication Process Developed by Fraunhofer .....	7
10. 42” Jet Engine Fan Blade – GE Research - Shanghai .....	8
11. Hip Implant Components Fabricated Using EBM (www.arcam.com).....	8
12. EBM Ti6Al4V Microstructure (left) versus DMLS CoCr Microstructure (right).....	9
13. Decision Tree for EBM.....	9
14. Pre/Post EBF3 Part (left) (nasa.gov), EBF3 Schematic (right) (sciaky.com).....	10
15. Decision Tree for EBF3 .....	10
16. Comparison of Additive Beam Processes.....	12
17. Examples of SLS Parts in Polymer (left) and Metal (right) (www.louisville.edu, www.protocam.com).....	12
18. Decision Tree for Selective Laser Sintering .....	13
19. Part Fabricated Using Stereolithography .....	13
20. Decision Tree for Stereolithography.....	14
21. Parts Fabricated Using FDM (www.peridotinc.com) .....	14
22. Decision Tree for Fused Deposition Modeling.....	14
23. Examples of Parts Fabricated Using 3D Printing (www.objet.com).....	15
24. Decision Tree for 3D Printing.....	15
25. Overview of Additive Manufacturing Technologies .....	16
26. Decision Tree for CNC Machining.....	17
27. Example of Micro CNC Machined Parts.....	17

## LIST OF FIGURES (*Cont'd*)

<b><u>Figure</u></b>	<b><u>Page</u></b>
28. Decision Tree for Waterjet.....	18
29. Examples of Parts Fabricated with Micro Waterjet.....	18
30. Laser Micromachining Decision Tree .....	18
31. Examples of Parts Fabricated with Laser Micromachining.....	19
32. Femtosecond Laser Machining.....	19
33. Ultrasonic Consolidation Example Part (left) and Schematic (right) www.solidica.com.....	20
34. Decision Tree for Ultrasonic Consolidation .....	20
35. POM Hybrid DMD and Dry EDM Machine .....	21
36. Example Parts Fabricated Using Multi-Material Processing.....	22
37. Marking ID Numbers via Dot Peening. Taken from the Website of DAPRA, a Provider of Dot Peening Equipment. www.dapramarking.com/dot-peen-marking.....	25
38. Decision Tree for Dot Peen Marking.....	25
39. Marking ID Numbers via Laser Marking (left) or Micromachining (right). Fiber Shown in Right Hand Image for Scale is ~60 Microns Wide. Images Provided by MLPC, a Laser Processing Company. www.mlpc.com.....	25
40. Decision Tree for Laser Marking.....	26
41. Examples of 2D Barcodes Marked by Dot Peening (left) and Laser Micromachining (right). Cells are 0.3 mm Wide .....	27
42. A Table Top CMM (left) and Example of a Point Cloud (Blue) Generated for a Component of a Larger Device. (www.cmmquarterly.com) .....	28
43. Decision Tree for Coordinate Measuring Machines.....	28
44. Examples of Complex Objects Modeled with Portable 3D Scanners. (Left from www.creaform3d.com and right from www.artec3d.com.) .....	29
45. Decision Tree for Portable 3D Scanner .....	29
46. Examples of Complex Objects Measured with Laser Scanners. (www.nelpretech.com/reverse_engineering.htm).....	29
47. Decision Tree for Laser Scanners .....	30
48. A CT Scanner (left) and Complex Object Measured with the Scanner (right). (www.nelpretech.com/reverse_engineering.htm).....	30

**LIST OF FIGURES (Cont'd)**

<b><u>Figure</u></b>	<b><u>Page</u></b>
49. Decision Tree for CT-X-Ray Scanning .....	31
50. Schematic of Industrial Computed Tomography Technique (left) and Complex Object Imaged in this Way (right). (www.xviewct.com).....	31
51. Decision Tree for Industrial Computed Tomography X-Ray Scanning .....	31
52. Example Assembly Design in Solidworks.....	32
53. Online Survey Responses for DDM Software.....	32
54. Online Survey Results for Diagnostics Used in DDM .....	33
55. Laser Scanning Equipment .....	34
56. Industrial CT Scanning of Aluminum Cast Part (www.toshiba-itc.com).....	34
57. Recommended Development Areas from Conferences on Additive Manufacturing Over the Past 2 Years.....	36



## 1.0 SUMMARY

Direct Digital Manufacturing (DDM) is a broad compilation of technologies capable of producing parts directly from a computer-generated file. The manufacturing technologies have been subdivided into 3 main categories including additive, subtractive, and hybrid. Supporting these technologies are upstream and downstream processes including reverse engineering, CAD/CAM, and diagnostics. This industrial base assessment reviewed each of these areas at a high level and provided insight into the technical maturity, capability, and opportunities for development of each technology. Through this assessment there was not one technology that served as a panacea, but rather technologies that served well in some applications but not others.

Additive manufacturing is the largest area of development in DDM due to the transition of these technologies from rapid prototyping to manufacturing and the promise of being able to build parts up layer-by-layer starting with raw material. For metal fabrication these processes include Direct Metal Laser Sintering (DMLS), Direct Metal Deposition (DMD), Electron Beam Melting (EBM), and Electron Beam Free Form Fabrication (EBF3). For polymers the technologies include Fused Deposition Modeling (FDM) and Selective Laser Sintering (SLS). Each of these technologies has distinct advantages and disadvantages. For metal parts DMLS and EBM show the most promise for net shape part fabrication. However, it was found that there is a significant amount of upstream and downstream processing required to manufacture parts using these technologies. One expert in DMLS stated that the machine time represents 20% of the entire process cycle time. Significant amounts of upstream engineering and programming combined with downstream heat treating, machining, and polishing can put total part cycle times in the range of weeks not days.

Subtractive manufacturing is a much more mature area than additive manufacturing. Technologies with higher maturity include computer numerical control (CNC) machining, electro-discharge machining (EDM), and water jet machining. These technologies are currently used in mass production of components across a variety of industries and are considered industrially hardened. Developing areas in subtractive manufacturing include femtosecond laser micromachining. The maturity of femtosecond laser technology makes this process a viable solution for removing not only metals and polymers but ceramics and semi-conductor materials as well without having to manage tool wear or consumables.

Hybrid manufacturing is the least mature of all technology areas. Processes such as ultrasonic consolidation show promise to combine additive manufacturing with integrated fiber optics and electronics. Other areas of hybrid manufacturing include a combination of additive and subtractive technologies on the same manufacturing platform. Hybrid is an area for further research and development to progress unique manufacturing capability that allows the combination of materials during processing.

Additive, subtractive, and hybrid technologies provide a method for fabricating components out of raw material. However, there are upstream and downstream technologies required to make the manufacturing technologies viable. Upstream technologies include reverse engineering and CAD/CAM technologies. Both of the areas have a high level of technical maturity and are being driven forward by the needs of multiple industries. Downstream technologies include diagnostics and part information data storage. Diagnostics are broken down into geometrical inspection and non-destructive part evaluation. Geometrical inspection is a mature technology that has been developed by a need for improved fidelity in measurement of manufactured parts

across many industries. Non-destructive part evaluation is area for further development to investigate the parts manufactured through DDM. Both of these technologies are expensive and require relatively long cycle times to gather part information.

DDM is a technology space that has the attention of many industries. The ability to directly manufacture parts with nothing more than a computer and a printer is a concept that excites the imagination of many engineers and scientist. However, the current reality is there are a broad range of technologies required to manufacture functional parts. These manufacturing technologies range in maturity and capability. The advancement of machines, materials, software, and energy sources over the past 20 years have moved technologies doing rapid prototyping to rapid manufacturing. Many advances are required to bring DDM into the mainstream.

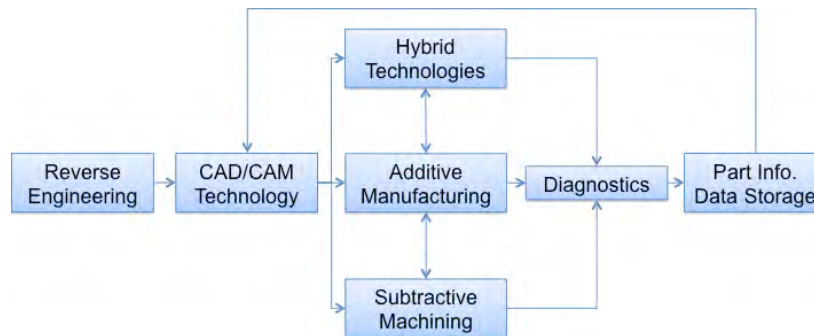
## 2.0 BACKGROUND ON DIRECT DIGITAL MANUFACTURING

Direct Digital Manufacturing (DDM) encompasses a broad range of technologies, which can be used to fabricate parts directly from an electronic file as shown in Figure 1.



**Figure 1. Direct Digital Manufacturing**

The computer aided drafting (CAD) file contains all the necessary geometrical information required to create the part. For the purposes of this program, the DDM processes have been grouped into common categories, which include subtractive, additive, and hybrid technologies. The upstream and downstream processes were also explored as a part of this program and the relationships are shown in Figure 2.

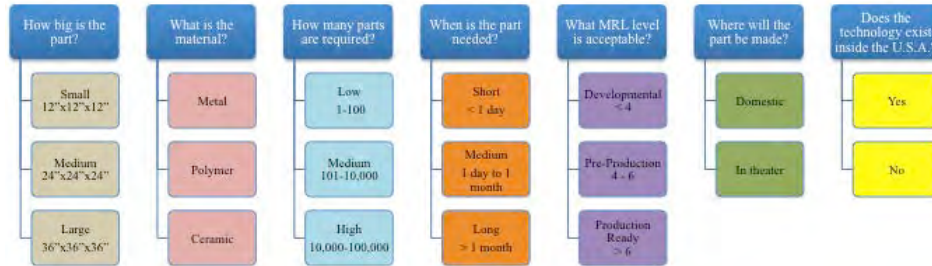


**Figure 2. Direct Digital Manufacturing Upstream and Downstream Process**

The upstream processes include reverse engineering and computer aided drafting (CAD) and computer aided manufacturing (CAM) technologies. Reverse engineering is used to gather information from an existing part, which can be translated into CAD data. CAD/CAM technology is used to generate digital part information and transform it into machine code. The machine code is loaded into an additive, subtractive, or hybrid process to create the part. The part is then checked using diagnostics including geometrical and non-destructive analysis. Part information data storage was the final area for review, which includes the ability to store detailed part geometry and manufacturing information on the part.

### 3.0 DATA COLLECTION METHODOLOGY

The data collection portion of the project required a variety of methods to gather and collate data. The first step was to create a decision tree (Figure 3), which could be used to characterize each process on a common platform. The decision tree allowed all direct digital manufacturing technologies to be characterized using seven key qualifiers.



**Figure 3. Decision Tree**

After the completion of the decision tree, data collection was completed using the following methods:

*Internet searches* – Each technology was thoroughly searched including equipment manufacturers, forums, and user websites.

*Interviews* – Key players were interviewed including researchers, users, and equipment manufacturers.

*Conferences* – Conferences were attended to review the on-going research in direct digital manufacturing technology.

*Industry Reports* – Were available industry reports were obtained and reviewed.

*Survey* – A comprehensive survey was completed and sent to researchers, users, and manufacturers in the industry.

In addition an analysis of the direct digital manufacturing market was accomplished by the Industrial Base Information Center (IBIC). The results of that effort are provided in Appendix F to this report.

## 4.0 FINDINGS AND DISCUSSION

### 4.1 Additive Manufacturing

Additive Manufacturing (AM) comprises a group of technologies that fabricates parts through a build up process. All of these technologies start with raw material and a CAD file. AM technologies have progressed from rapid prototyping to functional part fabrication over the past several years. At a high level these processes appear to be a perfect match for direct digital manufacturing. However, upon detailed investigation there is much more complexity than initially meets the eye.

#### 4.1.1 Direct Metal Laser Sintering

The Direct Metal Laser Sintering (DMLS) process is used to create metal parts by laser heat source melting metal powder in layer-by-layer part fabrication. The process is contained in an inert gas environment. The part build information is obtained directly a CAD file. Examples of parts created through this process are shown in Figure 4.



**Figure 4. Examples of Components Fabricated Using DMLS (www.electrooptics.com, www.eos.info)**

The leader in DMLS processing is EOS (www.eos.info), which is a German company. Per an EOS company presentation they have over 900 systems installed worldwide. The systems range in price from \$500-\$700K. Other top players in the industry include MTT (www.reinshaw.com) and Concept Laser (www.concept-laser.de). Based on all research it appears as though all DMLS equipment manufacturers are located in Europe.

The technology has been qualified through the decision tree which is shown in Figure 5.

Part Size	Material	Part Quantity	Part Cycle Time	MRL Level	Portability	Domestic/ Foreign
Small	Metal	Low				
		Medium	Medium	Pre-Prod.	Large Size/ High Power	Foreign
				Production Ready		

**Figure 5. Decision Tree for DMLS**

As shown in the decision tree the technology has limitations to small (12"x12"x12") parts and is only suitable for processing metals. There is also a limited number of metals available including stainless steel and cobalt chrome. The process is being used today to fabricate components. Per an interview with Greg Morris of Morris Technologies, this process requires engineering design knowledge, post process thermal treatments, post process machining (milling, drilling), and post

process polishing. Greg estimates that 20% of the process is in the equipment and the other 80% is in process knowledge and downstream processing.

DMLS is a fast growing technology area in DDM. The technology is currently being used to fabricate dental implants and other medical devices. The main limitations are the size of part, build rate, availability of materials, and in-process monitoring capability.

Based on an interview with Greg Morris of Morris Technology DMLS is a very capable technology for producing functional parts. Morris technology has 18 DMLS machines and is running CoCr, Stainless Steel, and Titanium alloys. The company is in the process of developing an aluminum alloy suitable for DMLS processing. According to Greg the market awareness of DMLS has increased rapidly over the past several years. The commercial sector has been much quicker than the government customer to adopt the technology. Greg believes many of the advances in DMLS are occurring as these commercial applications are being developed, and since this development is privately funded these advances are not being seen in the public domain. The total process cycle time for a DMLS part is in the range of 2 weeks. This includes engineering design, CAD/CAM, DMLS processing, post-process heat treating, machining, and polishing. The DMLS machine time only makes up 20% of the process and the remaining time is involved in upstream and downstream processing. Greg predicts the DDM market to be in the range of \$9-\$10 billion in 10 years and estimates the current market size at \$100 million. He also mentioned that flight critical hardware is currently being produced using DMLS and the mechanical performance is better than wrought material.

#### **4.1.2 Direct Metal Deposition**

Direct metal deposition (DMD) uses a focused laser beam combined with coaxial powder metal delivery to fabricate component. DMD is also known as Laser Engineered Net Shaping (LENS) and Laser Free Form Fabrication (LF3). This process is similar to DMLS with the exception of powder delivery through a nozzle for DMD and bed-based for DMLS. DMD is typically used for repair, cladding, and add-on features but can also be used for complete part fabrication.



**Figure 6. Laser Engineering Net Shaping (LENS) in Process (www.sandia.gov)**

This process has the advantage over DMLS in its ability to produce much larger components. There is also the advantage of being able to mix different metals through the nozzle to create custom alloys. This process is typically used to make near net shaped components with secondary subtractive operations to finish part fabrication. Figure 7 details the decision tree for this technology.

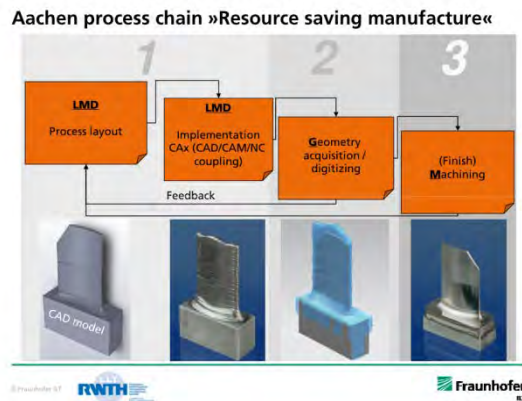
Part Size	Material	Part Quantity	Part Cycle Time	MRL Level	Portability	Domestic/ Foreign
Small	Metal	Low	Short	Develop.		Domestic
Medium			Medium	Pre-Prod.	Large Size/ High Power	
Large						

**Figure 7. Decision Tree for DMD**

POM ([www.pomgroup.com](http://www.pomgroup.com)) (Figure 8) and Optomec ([www.optomec.com](http://www.optomec.com)) are both US based companies developing and selling DMD equipment. Both companies are focusing on large scale (greater than 12”x12”x12”) components, which the DMD process is well suited. Fraunhofer has also made great strides using this technology to create near net shape BLISK components, which is funded through a 10.25M Euro program call TurPro (Figure 9). Using DMD a single BLISK blade can be fabricated in less than 2 minutes by employing a 10kW disk laser and coaxial powder delivery system. The GE Research Center in Shanghai has fabricated a 42” jet engine fan blade using DMD (Figure 10).



**Figure 8. POM DMD System Combined with Subtractive Femtosecond Laser Processing**



**Figure 9. BLISK DMD Fabrication Process Developed by Fraunhofer**



**Figure 10. 42” Jet Engine Fan Blade – GE Research - Shanghai**

Deposition rates for the DMD process can be up to 150 mm<sup>3</sup>/s based on reports from the Fraunhofer TurPro program. This makes the process industrially viable for large part fabrication.

#### **4.1.3 Electron Beam Melting**

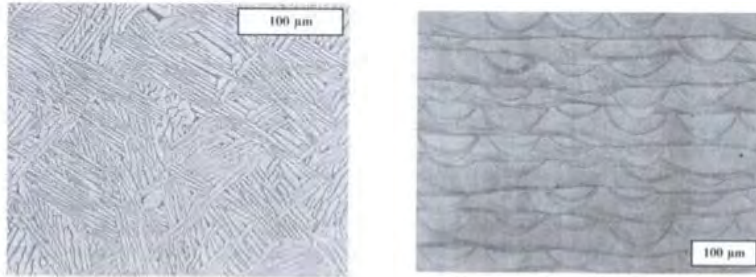
Electron Beam Melting (EBM) is a process where an electron beam is used as a heat source to melt metal powder in layer-by-layer part fabrication. Parts are fabricated in a vacuum and the electron beam heat source can hold the build chamber at an annealing temperature for the duration of the part fabrication cycle. The part build information is obtained directly from a CAD file. An example of parts fabricated via EBM is shown in Figure 11.



**Figure 11. Hip Implant Components Fabricated Using EBM (www.arcam.com)**

EBM is very similar to DMLS with the primary difference being the heat source. The ability of the heat source to maintain an annealing temperature during the build is evident in the part microstructure shown in Figure 12.





**Figure 12. EBM Ti6Al4V Microstructure (left) versus DMLS CoCr Microstructure (right)**

The anisotropic microstructure of the DMLS process requires post process heat-treating to normalize the material. The EBM process does not require this post process heat-treating.

The decision tree for EBM is shown in Figure 13. The main disadvantage of EBM is the resultant surface finish. The process creates a relatively rough outer surface of the part, which requires post part polishing or machining.

Part Size	Material	Part Quantity	Part Cycle Time	MRL Level	Portability	Domestic/ Foreign
Small	Metal	Low				
			Medium		Large Size/ High Power	Foreign
				Production Ready		

**Figure 13. Decision Tree for EBM**

Based on an interview with Kevin Slattery of Boeing over 80% of their titanium parts could be fabricated using the Arcam system. The processing time for a baseball size part takes around 15 hours and the rates would need to increase 2 to 4 times to make EBM a cost effective process. 50% of the production time is on the machine and it could take up to 3 hours of post machining to bring the part into tolerance. Boeing has a bracket produced using EBM and they found the process to be 2 to 5 times cheaper than conventional processing due to the time savings. Overall, EBM has further development to be used across a larger number of applications but it has been proven effective in a selective number of applications. Further area of development include: more qualified raw materials, machine improvements (better uptime and online process monitoring), bigger build chamber, better surface finish, and reduced capital cost.

#### 4.1.4 Electron Beam Free Form Fabrication

Electron Beam Free Form Fabrication (EBF3) is a process, which uses an electron beam as the heat source and an off-axis metal wire to fabricate parts. The process is used primarily for near net shaped additive manufacturing and requires post subtractive processing to fabricate finished parts. The process is specialized for aerospace applications with Sciaky ([www.sciaky.com](http://www.sciaky.com)) being the primary developer of the equipment. Figure 14 shows a schematic of the process and parts fabricated.

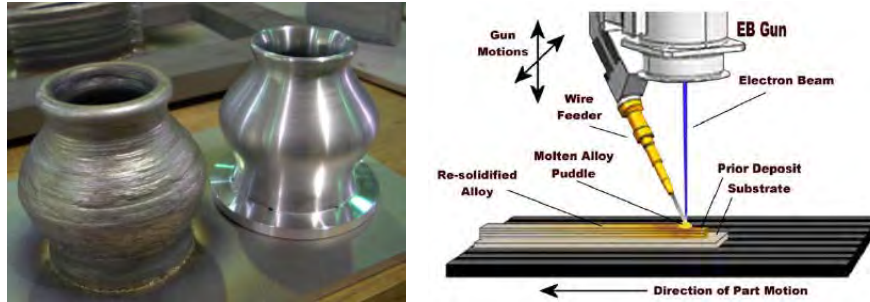


Figure 14. Pre/Post EBF3 Part (left) (nasa.gov), EBF3 Schematic (right) (sciaky.com)

Part Size	Material	Part Quantity	Part Cycle Time	MRL Level	Portability	Domestic/ Foreign
Small	Metal	Low			Small Size/ Low Power	
			Medium	Pre-Prod.	Large Size/ High Power	Foreign

Figure 15. Decision Tree for EBF3

The advantages of EBF3 are the ability to process difficult or specialty alloys in a vacuum into a near net shape. The process is capable of 7-10 lbs/hour deposition rate is high (need number) when compared to EBM, DMD, and DMLS.

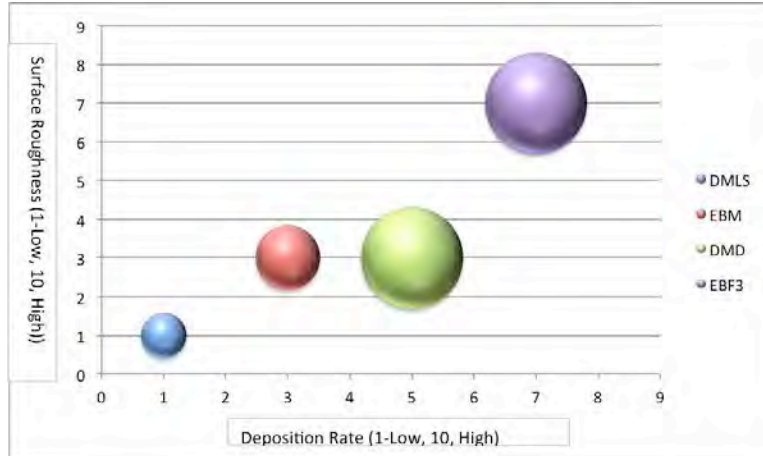
Based on an interview with Kevin Slattery of Boeing and Craig Brice of NASA, the EBF3 process provided excellent build rates with typical deposition rates being in the 7-10 lb/hour range. However, the process is only suited for near net shape fabrication and requires post process machining to bring the part into tolerance. However, the process can produce some of the largest parts compared to all of DDM processing with sizes up to 4 ft x 2 ft x 2 ft.

#### 4.1.5 Summary of Additive Beam Based Processes

The four additive beam based processes including DMLS, DMD, EBM, and EBF3 have distinct advantages and disadvantages. Each technology has enabled the fabrication of metal parts using a CAD file and raw material. The main areas for continued development of these technologies include:

- Feature Size vs. Deposition Rates
  - Deposition rates need to increase 2 to 3 times for full part fabrication while maintaining surface finish and feature size.
  - Limited part size.
- Post Processing
  - Eliminate the need for support structures and post processing
  - All processes require some or all of the following polishing, machining, and heat treating.

- Characterization of Materials
  - Limited material choices.
  - Limited characterization.
  - Fundamental research into new materials made specifically for AM processes
- Capital Equipment
  - Equipment is expensive and limited number of suppliers.
  - Equipment is not consistent from one machine to the next.
  - Domestic source of equipment
- Process Monitoring
  - Limited development on process control and feedback.
- Process Modeling
  - Limited knowledge/development in process modeling
  - Residual Stress/Distortion Prediction
- Education
  - Training – Common training platform for technicians.
  - Design – Improved training of designers on how the technology can be exploited.
  - Process Knowledge – All current process knowledge is proprietary and there is no open forum or handbook on how to use the technology.
- Government Consortium
  - Europe has multiple consortia working to solve the above issues
  - US has no funded consortia at this time.

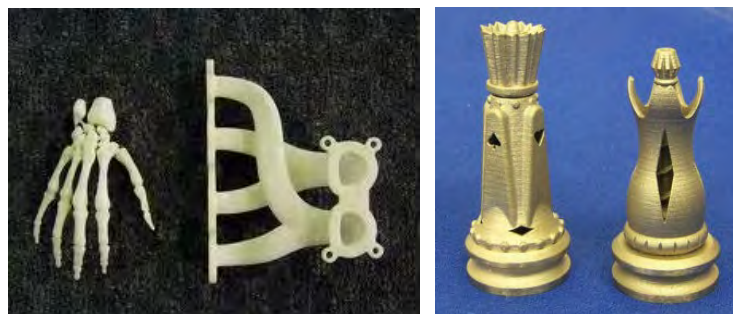


**Figure 16. Comparison of Additive Beam Processes**

Figure 16 shows a qualitative comparison between the four additive beam processes. The size of the data point equates to the size of the part the process can fabricate. The DMLS and EBM processes are well suited for small (<12"x12"x12") parts that require better surface finish with minimal post processing. The DMD and EBF3 processes are better suited for medium to large parts (>12"x12"x12") but will require more post processing due to lower quality surface finish. Based on the review of all four technologies there appears that there is an inverse relationship between surface roughness and deposition rate, which equates to an decrease in part surface finish with an increase in material deposition rate.

#### 4.1.6 Selective Laser Sintering

Selective Laser Sintering (SLS) is a laser-based additive manufacturing process that is capable of manufacturing parts in metals, polymers, and ceramics in a layer-by-layer build up. In the case of metals, the laser is melting a binder, which holds the powder material together versus fusing the part material directly. This produces a weaker part that requires additional post processing and backfilling for metals. For polymers, the laser fuses the polymer together directly. The process is excellent for producing rapid prototypes and functional parts in polymers. Example parts are shown in Figure 17.



**Figure 17. Examples of SLS Parts in Polymer (left) and Metal (right)**  
([www.louisville.edu](http://www.louisville.edu), [www.protocam.com](http://www.protocam.com))

The main players in this market include EOS ([www.eos.info](http://www.eos.info)) and 3D Systems ([www.3dsystems.com](http://www.3dsystems.com)). The technology is being used to manufacture polymer components for the Aerospace industry. Based on an interview with Scott Martin of Boeing, SLS is used to fabricate over 80 parts for the F-16. The process is well suited for rapid part manufacturing of polymer parts. However, there are cost considerations when compared to injection molding because of the low cost of the raw material for this process. These cost considerations make the process well suited for low volume manufacturing. The decision tree results are shown in Figure 18.

Part Size	Material	Part Quantity	Part Cycle Time	MRL Level	Portability	Domestic/ Foreign
Small	Metal	Low	Short			Domestic
Medium	Polymer	Medium	Medium	Pre-Prod.	Large Size/ High Power	Foreign
	Ceramic			Production Ready		

**Figure 18. Decision Tree for Selective Laser Sintering**

There are several areas of desired improvement for the SLS process which include improved surface finish, reduced cost of capital, machine to machine consistency, open architecture equipment, formalized test platform, and intelligent feedback and control.

#### 4.1.7 Stereolithography

Stereolithography (SLA) is a laser-based process, which can fabricate parts through a layer-by-layer build up of a liquid photo-curable polymer. The process is typically used only for rapid prototyping and an example part fabricated with this process is shown in Figure 19.



**Figure 19. Part Fabricated Using Stereolithography**

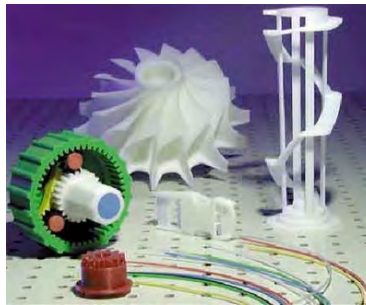
The leading company producing SLA equipment is 3D Systems ([www.3dsystems.com](http://www.3dsystems.com)). The decision tree for this process is shown in Figure 20.

Part Size	Material	Part Quantity	Part Cycle Time	MRL Level	Portability	Domestic/ Foreign
Small		Low				Domestic
Medium	Polymer		Medium		Large Size/ High Power	Foreign
				Production Ready		

**Figure 20. Decision Tree for Stereolithography**

#### 4.1.8 Fused Deposition Modeling

Fused Deposition Modeling (FDM) uses a polymer filament fed through a head extrusion nozzle to build parts up in a layer by layer process. FDM is limited to polymers but can fabricate parts with strength near that of the parent material. Figure 21 shows examples of parts fabricated through the FDM process.



**Figure 21. Parts Fabricated Using FDM (www.peridotinc.com)**

The key player in the industry is Stratasys/Hewlett Packard. There is also a movement to produce low cost FDM equipment through companies such as MakerBot and Bits for Bytes. The low cost of the technology makes it suitable for hobbyist and early adopters. The decision tree for FDM is shown in Figure 22.

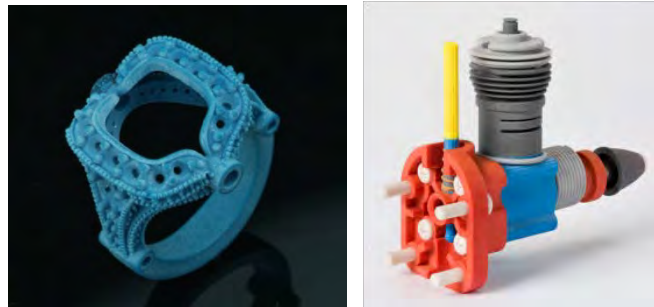
Part Size	Material	Part Quantity	Part Cycle Time	MRL Level	Portability	Domestic/ Foreign
Small		Low				Domestic
Medium	Polymer		Medium		Large Size/ High Power	Foreign
				Production Ready		

**Figure 22. Decision Tree for Fused Deposition Modeling**

#### 4.1.9 3D Ink-Jet Printing

3D Ink-Jet Printing used a multi-channel ink jet print head to deposit a liquid adhesive on a bed of powdered polymer. Another variation of this process deposits tiny droplets of thermoplastic and wax materials directly from the print head. Both variations can be used to fabricate parts in

a layer-by-layer build up process. Examples of parts fabricated using this process are shown in Figure 23.



**Figure 23. Examples of Parts Fabricated Using 3D Printing (www.objet.com)**

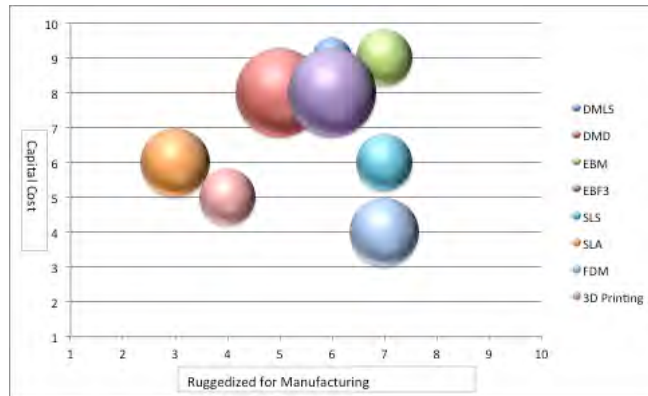
Players in the 3D printing industry include Objet (www.objet.com) Solidscape (www.solid-scape.com), VoxelJet (www.voxeljet.de), and 3D Systems (www.3dsystems.com). Similar to SLA the technology is well suited for prototype fabrication but the parts are not robust enough for rugged application. The decision tree for 3D printing is shown in Figure 24.

Part Size	Material	Part Quantity	Part Cycle Time	MRL Level	Portability	Domestic/ Foreign
Small		Low	Short		Small Size/ Low Power	Domestic
Medium	Polymer		Medium	Pre-Prod.		Foreign
				Production Ready		

**Figure 24. Decision Tree for 3D Printing**

#### 4.1.10 Additive Manufacturing Summary

The Additive Manufacturing (AM) industry contains a number of different technologies that continue to progress towards Direct Digital Manufacturing. Figure 25 displays a breakdown of the technologies by manufacturing ruggedness (x-axis), capital cost (y-axis), and part size (bubble size). Based on this review the technologies can be broken down into two main subgroups. The first subgroup contains technologies that have the capacity to directly produce parts in metals and polymers, which include DMLS, DMD, EBM, EBF3, SLS, and FDM. All of these technologies have the inherent ability to produce usable components directly from a CAD file. The remaining technologies are limited by the material sets and are only suitable for prototype or form models, which include SLA and 3D printing.



**Figure 25. Overview of Additive Manufacturing Technologies**

In addition to interviews, MLPC also conducted an online survey across academic, industry, equipment, and service providers in the additive manufacturing industry. The complete survey results are listed in Appendix A.

#### Survey Results for Metal Parts

- Build Speed and Surface Roughness were each ranked in the top 3 most important aspects for improvement/development for four of the six AM technologies that build metal parts. In fact, they were ranked most important in two technologies each.
- The results for Maximum Part Size were split. This aspect was ranked in the top three priorities for three of the six technologies, but was not of great importance to the respondents of the other three.
- Except for Electron Beam Melting, in which it was ranked as the most important aspect for development, In-Process Monitoring was ranked in the bottom half for the other technologies.
- Surprisingly, respondents did not seem to place Raw Material Variety very high on their list of priorities of aspects needing improvement.

#### Survey Results for Plastic Parts

- Three out of the four AM technologies that build polymer parts (SLA, SLS Polymers, 3D/Inkjet Printing, and FDM/FFF) showed Finished Part Strength as being either the first- or second-most important aspect for improvement/development.
- Raw Material Variety and Build Speed were other aspects that respondents generally seemed to place emphasis on for improvement/development. These aspects usually fell in the top half of priorities for the different technologies.
- On the other hand, Maximum Part Size and Amount of Post Processing Required did not generally seem to be of major concern to the respondents. Neither of these aspects fell in the top 50% of choices for needing improvement/development.

Overall, the additive manufacturing technologies are in an early stage of technical development and making a transition from prototyping to production. This transition is occurring in private industry through the design and testing of parts across many industries. There is a significant



amount of continued development required for full qualification into critical applications. This transition will occur over the next ten years as the technical challenges continue to be solved.

## 4.2 Subtractive Manufacturing

Subtractive manufacturing includes all technologies used to remove material to create a part. These process starts with a piece of raw material and a CAD file. These technologies include computer numerical controlled (CNC) machining, electro-discharge machining (EDM), laser machining, and waterjet machining. Each of these technologies is described in detail in the following sections.

### 4.2.1 CNC Machining

Computer numerical control (CNC) machining uses a computer controlled motion system combined with a rotating machine tool to fabricate parts. This technology has been used in industrial manufacturing since the 1980s. There are a large number of companies across the world that manufactures CNC equipment. The leaders in this industry include Haas and Morel and they produce thousands of CNC machines a year.

The decision tree for CNC machining is shown in Figure 26.

Part Size	Material	Part Quantity	Part Cycle Time	MRI Level	Portability	Domestic/ Foreign
Small	Metal				Small Size/ Low Power	Domestic
Medium	Polymer	Medium	Medium		Large Size/ High Power	
Large		High	Long	Production Ready		

**Figure 26. Decision Tree for CNC Machining**

In addition to large scale CNC machining which can produce parts in excess of 36"x36"x36" a micro version of the technology was also reviewed. Micro-CNC machining uses higher resolution motion systems coupled with high (>50,000 RPM) spindle speeds. Examples of parts fabricated with this technology are shown in Figure 27.



**Figure 27. Example of Micro CNC Machined Parts**

### 4.2.2 Waterjet Machining

Waterjet machining uses a higher pressure water nozzle combined with an abrasive to cut components. This technology is generally used to cut through a component leaving a kerf of (0.010”-0.015”) behind. The process does not introduce any thermal input into the material and can be used on a wide range of materials. Waterjet machining was developed in the 1950s. The process is used across a wide range of industries and key players providing equipment include Flow and OMAX. The decision tree for waterjet machining is shown in Figure 28.

Part Size	Material	Part Quantity	Part Cycle Time	MRL Level	Portability	Domestic/ Foreign
Small	Metal		Short			Domestic (AJW)
Medium	Polymer	Medium	Medium		Large Size/ High Power	
Large	Ceramic	High		Production Ready		

Figure 28. Decision Tree for Waterjet

Similar to CNC machining there is also a micro version of the technology which is capable of producing parts with a kerf width down to 80 microns. Figure 29 provides examples of parts cut using micro waterjet.



Figure 29. Examples of Parts Fabricated with Micro Waterjet

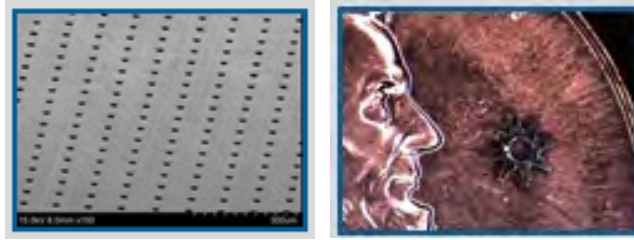
### 4.2.3 Laser Micromachining

Laser micromachining uses pulses from a focused laser beam to ablate small increments of material from a surface. For longer nanosecond pulses, ablation is by melt and evaporation with significant heat transfer. Ultrashort pulses lead to direct ablation and minimal heat transfer. The process works well on most opaque and some transparent materials. The decision tree for laser micromachining is shown in Figure 30.

Part Size	Material	Part Quantity	Part Cycle Time	MRL Level	Portability	Domestic/ Foreign
Small	Metal	Low				Domestic
	Polymer	Medium	Medium	Pre-Prod.	Large Size/ High Power	
	Ceramic		Long	Production Ready		

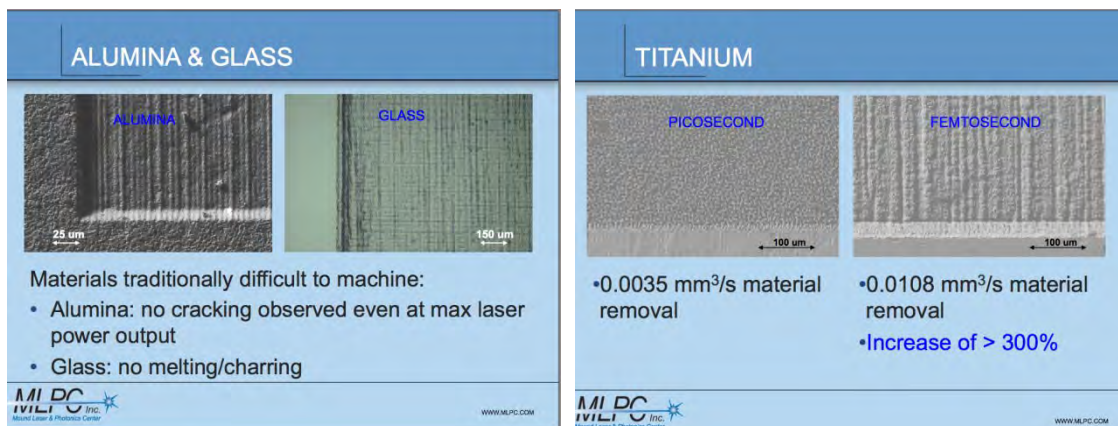
Figure 30. Laser Micromachining Decision Tree

The equipment manufacturers for this technology include Resonetics, 3D Micromac, and JPSA. The technology is used across a wide range of industries including medical device, aerospace, and microelectronics. Figure 31 provides examples of features laser micromachined.



**Figure 31. Examples of Parts Fabricated with Laser Micromachining**

One area of laser micromachining that has been recently developed is ultrafast laser processing. This technology employs picosecond and femtosecond laser pulses to ablate material with minimal or no heat input. Femtosecond laser micromachining was studied as a part of this program due to its potential benefits to the additive manufacturing process. Figure 32 provides examples of surfaces machined using a femtosecond laser.



**Figure 32. Femtosecond Laser Machining**

#### 4.2.4 Subtractive Manufacturing Conclusions

Subtractive manufacturing processes including CNC, waterjet, and EDM are considered to be industrially hardened and mature technologies. These processes are well suited to support Direct Digital Manufacturing through the ability to selectively remove material. Laser micromachining is a developing technology that has benefits in the area of precision material removal.

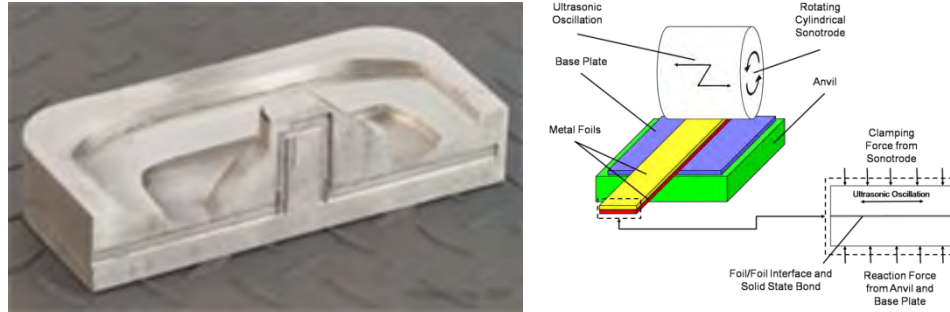
Specifically femtosecond laser micromachining shows promise for material removal without any damage to the part or heat affected zone.

#### 4.3 Hybrid Manufacturing

Hybrid manufacturing include the use of non-traditional methods to fabricate components including ultrasonic consolidation, direct-write electronics, additive/subtractive combined technologies, and multi-material processing.

### 4.3.1 Ultrasonic Consolidation

Ultrasonic Consolidation is a process that uses an ultrasonic welding process to buildup a part a layer by layer. The process is combined with CNC machining to remove the unwanted material and generate the desired part shape. Solidica ([www.solidica.com](http://www.solidica.com)) is the inventor of ultrasonic consolidation and sells capital equipment to support the technology. A schematic of the process and a sample part is shown in Figure 33.



**Figure 33. Ultrasonic Consolidation Example Part (left) and Schematic (right)**  
[www.solidica.com](http://www.solidica.com)

The advantage of this technology is the combination of different types of materials including aluminum and fiber optics. The disadvantage is the process is limited to malleable metals that can be ultrasonically welded. The decision tree for this process is shown in Figure 34.

Part Size	Material	Part Quantity	Part Cycle Time	MRL Level	Portability	Domestic/ Foreign
Small	Metal	Low	Short	Develop.		Domestic
			Medium	Pre-Prod.	Large Size/ High Power	

**Figure 34. Decision Tree for Ultrasonic Consolidation**

Ultrasonic consolidation is a developing process for hybrid manufacturing and provides a good capability for the combination of malleable materials and embedded electronics and fiber optics.

### 4.3.2 Direct Write Electronics

Direct Write Electronics is not an additive part manufacturing technology but could be used to augment these technologies to incorporate conformal electronics. Companies that produce equipment for this include Optomec ([www.optomec.com](http://www.optomec.com)), Sciperio ([www.sciperio.com](http://www.sciperio.com)), and Mesoscribe ([www.mesoscribe.com](http://www.mesoscribe.com)). All of these technologies use a variation of inkjet printing or thermal spray technology to directly apply metal particles to the surface of part, which are fused in process or post process.

### 4.3.3 Additive/Subtractive Manufacturing Technologies

Additive and Subtractive manufacturing technologies are described in detail in the above sections. However, some companies have taken the next step and combined these technologies to take full advantage of both. The POM group has a current program with the US Navy and the hybrid machine being developed is shown in Figure 35. This application uses direct metal deposition and dry electro-discharge machining. Additive manufacturing also uses post process machining but this is not typically done on the same machine tool. As these technologies continue to advance it is likely that a complete integration of the process will be incorporated into one machine tool for maximum efficiency and through put.

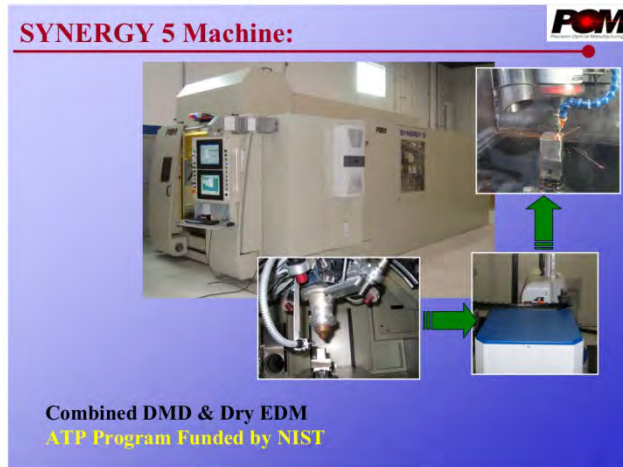


Figure 35. POM Hybrid DMD and Dry EDM Machine

### 4.3.4 Multi-Material Processing

A next generation application of additive manufacturing technology is the incorporation of multiple materials into one process to create graded material structures. A futuristic vision of this technology would be the ability to make any material through the combination of basic alloying elements into the process. To date most of the material development has included turning the standard material sets into powders, which are re-melted in the additive process. Multi-material processing offers the next level of development in which two or more of these standard materials are combined in the process. Figure 36 provides an example of parts created in the process.

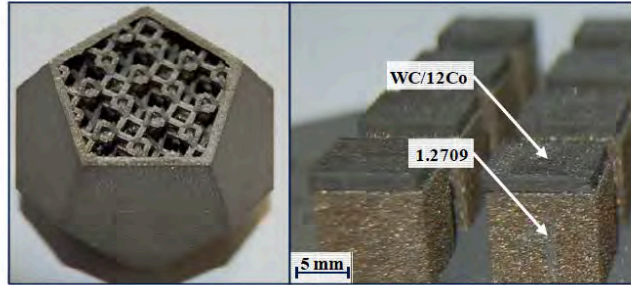


Fig. 1: Complex geometric parts produced by selective laser melting; a dodecahedron with internal structures (left) and a one dimensional multi-material structure (right)

### Figure 36. Example Parts Fabricated Using Multi-Material Processing

#### 4.4 Part Information Data Storage

One of the primary values of DDM is the ability to economically make small numbers of any particular part. This makes the paradigm ideal for making replacement parts on an as-needed basis. To facilitate this, it would be valuable to store information needed for the manufacture of any given part directly with the part. This can facilitate finding full details on the part design, dimensions and fabrication instructions or possibly eliminate the need to look up this information. This can be especially important when replacing parts for vehicles or platforms that are intended to remain in service for long periods of time, or are being enabled to continue service through sustainment efforts. In these situations, it is possible that original drawings and specifications may become lost over time with the degradation of records and institutional knowledge. Having key information directly on the part can obviate these concerns.

This section addresses two issues: What information to store with a part, and techniques for storing the information.

##### 4.4.1 Types of Information to Store

The information of interest to store on a part is that which can be used to guide any DDM technique, or combination of techniques, in accurate reproduction of the part. This may include dimensions, exact material specification, minimum materials requirements where a variety of materials may be acceptable, directions for specific fabrication techniques (required equipment, or operating settings, for example), directions for finishing the part (e.g., heat treatments, passivation, etc.) and directions for required inspection and validation methods. The total amount of this information may be minimal or quite extensive depending on the part.

There are two basic approaches to associating the above information with the part in question. The first is to comprehensively encode all of the required information directly onto the part. The second is to apply only an identifier number that specifies where the complete set of information can be accessed. (Historically, the latter option, in the form of a producer or supplier specific part number, is the only information typically encoded on a part. A modern alternative to this is the Global Unique Identifier (GUID), described in a subsequent section.)

Each of these methods has advantages and drawbacks. The advantage of comprehensive encoding is that no recourse to other resources is required to begin fabrication. This eliminates dependence on third parties for reliable data storage. It also cuts down on time and expense to access information. If one is attempting to fabricate parts in an environment of active military

engagement, there is no dependence on communication lines. However, there are also serious limitations to comprehensive encoding. Many parts simply do not have enough space to hold the necessary information. The physical marking of the information on the part may be inordinately time consuming. Also, damage or wear to the part (which is a near certainty given that the part needs to be replaced) is likely to destroy or efface portions of the information on the part. Finally, if details of the part are classified or proprietary, it may be undesirable to include the information on the part itself. In general, comprehensive on-part data storage will only be practical for parts that are simple, non-proprietary and not too small.

Marking of an ID number on the part reintroduces dependence on an external library of part information, but addresses all the challenges of comprehensive on-part data storage. An ID number takes up relatively little space and is fast to mark. It can be applied with redundancy to increase the chance that a complete and legible number can be discern after the part suffers damage or wear. Finally, an ID number removes the primary part information to a point where its proprietary nature can be protected. For most parts and situations, ID numbers will remain the best method to store fabrication information on the part, particularly when implementing the GUID concept discussed below.

#### 4.4.2 GUID

A globally unique identifier (GUID) is reference number system originally developed to generate unique identifiers in computer software, but the concept is readily adapted for general inventory and database purposes. A GUID is normally represented as a 32-character hexadecimal string (equivalent to a 128-bit binary number).

To use a GUID for part information storage, one must do three things: Generate the GUIDs, apply them permanently to a part, and create and maintain a database that contains the part information associate with each GUID.

Generation of valid GUIDs is trivial. The total number of unique GUIDs ( $>10^{38}$ ) is so large that the probability of random duplication is negligible, even when an enormous number of GUIDs are simultaneously in service. It is literally true that if GUIDs were randomly assigned to every insect on earth<sup>1</sup> (estimated as  $10^{19}$  individuals), the odds that there would be even a single instance of a duplicated GUID is less than 50%. This is so far beyond the number of items to be tracked in any practical database that identifiers can be assigned by any pseudo-random number generator(s) without concern of confusing parts. The GUIDs can be assigned not just to each type of part, but to each and every *individual* part. Further, because the numbers can be assigned randomly, they do not need to be assigned by central governing body. Any given fabricator of a part can generate a GUID for each part he makes without any fear of duplicating one already in existence (as long as the generation is done randomly.)

Application of a GUID to a part is straightforward, and methods of doing so are discussed in the following sections.

That leaves the issue of creating and maintaining the GUID database. This is a simple, if potentially large, exercise in information technology and data storage, solvable by many providers with off-the-shelf technology and equipment. The main issues include:

---

<sup>1</sup> Estimated as  $10^{19}$  individuals by the Smithsonian. [http://www.si.edu/Encyclopedia\\_SI/nmnh/buginfo/bugnos.htm](http://www.si.edu/Encyclopedia_SI/nmnh/buginfo/bugnos.htm)

- Determining what data will be stored with each GUID: With sufficient capacity, CAD files to support DDM of each part can be stored in addition to more conventional drawings, specifications and instructions. Further, since every individual part can have its own GUID, it would be possible to store and update part histories (installation date, last maintenance date, notes taken at last maintenance, hours of cumulative service, etc.)
- Protocols for accessing the database: This includes not only the specific technical means of accessing and downloading the information needed to duplicate a part or interest, but also the methods for ensuring the security of the information. In some cases, it may be useful to produce and distribute subset databases that can be stored at a local fabrication facility (perhaps in an area of limited or suspect electronic connectivity).
- Protocols for adding to the database: Since individual fabricators will be able to generate random GUIDs to cover each part they make, they will need a method for reporting the new GUIDs and part information to the library.

It is beyond the scope of this report to suggest specific methods for setting up such a database.

#### **4.4.3 Alphanumeric Marking**

Alphanumeric marking of a part is the most straight forward way of encoding a GUID on a part. It has the advantage of being readily understood by a human operator, but is less well adapted to optical readers. Marking of parts can be accomplished by conventional engraving techniques, dot peening or laser marking. Use of ink generally is not advisable due to likelihood of degradation.

The image in Figure 37 shows a typical example of how lettering is applied to metal parts using dot peening. An advantage of dot peening on metal is that it introduces compressive stress, which is generally considered to be safer than engraving with respect to the likelihood of reducing the fatigue life of a part. Dot peening also marks deep enough to be legible after substantial wear. A limitation is that dot peening is only applicable to materials are ductile and will permanently hold a deformation. Therefore it is not appropriate for brittle ceramics and may not retain well in some plastics.



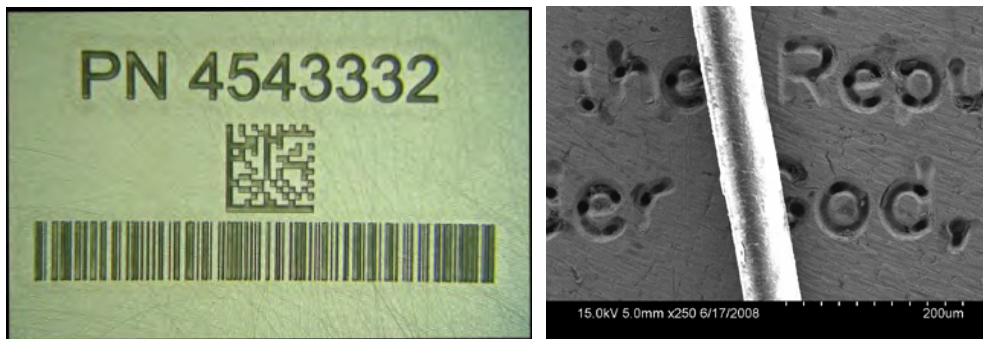


**Figure 37. Marking ID Numbers via Dot Peening. Taken from the Website of DAPRA, a Provider of Dot Peening Equipment. [www.dapramarking.com/dot-peen-marking](http://www.dapramarking.com/dot-peen-marking)**

Part Size	Material	Part Quantity	Part Cycle Time	MRL Level	Portability	Domestic/ Foreign
	Metal	Low			Small Size/Low Power	Domestic
Medium		Medium	Medium			Foreign
Large		High		Production Ready		

**Figure 38. Decision Tree for Dot Peen Marking**

Figure 38 shows examples of laser marking and micromachining to produce alphanumeric. Advantages of laser marking include speed and the ability to address virtually any material. Laser marking requires only line-of-sight to the mark area, and not access for a physical tool head. Of particular advantage for small parts is the ability to make the font size extremely small. Figure 39 shows, for example, lettering marked into the surface of a penny with characters less than 100 microns tall. This allows for redundant or relatively concealed marking.



**Figure 39. Marking ID Numbers via Laser Marking (left) or Micromachining (right). Fiber Shown in Right Hand Image for Scale is ~60 Microns Wide. Images Provided by MLPC, a Laser Processing Company. [www.mlpc.com](http://www.mlpc.com)**

Part Size	Material	Part Quantity	Part Cycle Time	MRL Level	Portability	Domestic/ Foreign
Small	Metal	Low	Short		Small Size/Low Power	Domestic
Medium	Polymer	Medium				Foreign
Large	Ceramic	High		Production Ready		

Figure 40. Decision Tree for Laser Marking

4.4.4 2D Bar Codes

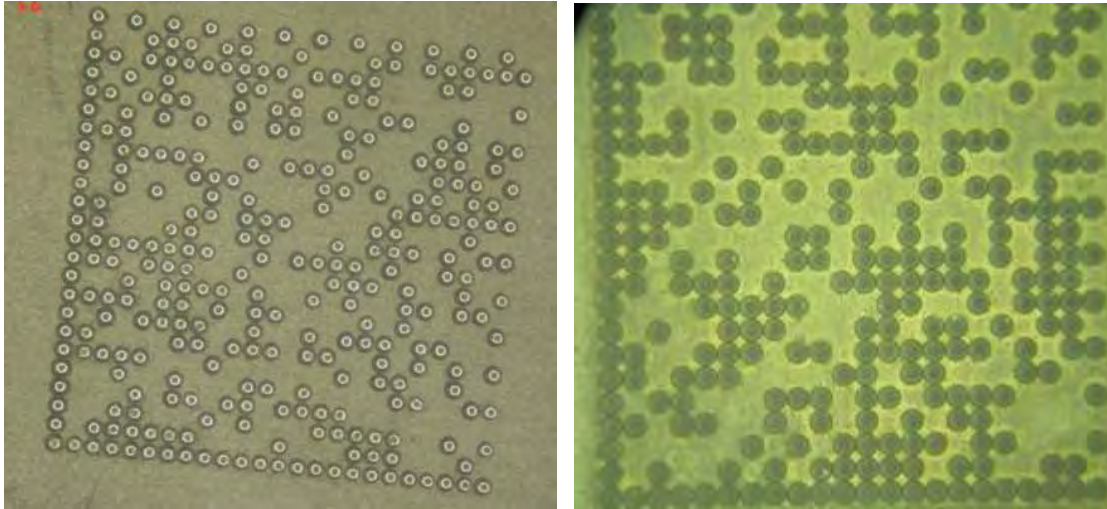
A popular alternative to alphanumeric is barcoding, with 2D (or matrix) barcodes likely to be the most appropriate for most part marking. A 2D barcode encodes information equivalent to alphanumeric as an array of filled and empty cells in a square matrix. Typically, some of the cells are devoted to alignment and registration of the pattern orientation, and the rest are devoted to the actual recorded information. The amount of information that can be stored depends on the size of the matrix. The amount of space that a particular matrix must occupy is limited primarily by the resolution of the reader technology. A common resolution is 0.33 mm/cell, though better can be achieved with high resolution technologies.

There are a large number of 2D barcode encoding standards, but public and proprietary. An example of a popular format is the QR (quick response) code. The largest QR codes can store 4000+ alpha-numeric characters. They can also be coded with redundancy, up to 30%, by reducing the number of characters. As an example, the QR code shown at right encodes this paragraph.



If this QR code were marked at 0.33 mm resolution, it would fit inside a 23 mm (< 1”) square. A QR code that contained only a GUID number would fit in a square just 8.25 mm on a side.

The physical marking of barcodes on parts can be accomplished by the same techniques of dot peening and laser marking or micromachining described in the previous section. Figure 41 shows examples of 2D bar codes marked by dot peening (left) and laser micromachining (right). The contrast for laser marking tends to be better, but both have been shown to be compatible with optical readers.



**Figure 41. Examples of 2D Barcodes Marked by Dot Peening (left) and Laser Micromachining (right). Cells are 0.3 mm Wide**

The decision tree for 2D barcode marking is essentially the same as those presented for alphanumeric marking. The one essential difference is that 2D barcodes require an optical reader. However, the technology for this is so ubiquitous (readily available as apps on smart phones) that it does not affect the decision tree.

#### **4.4.5 RFID**

The possibility of using radio frequency identification (RFID) tags for data storage on parts was investigated but found to be inappropriate. An RFID tag is basically a small antenna with attached integrated circuit chip designed to encode a number and respond to a wireless interrogation device. However, RFID tags cannot be directly produced on a part. They are instead a separate attachment that can become separated from a part. RFID tags typically encode less information than a GUID. Also, they are not very robust. They are more appropriate for inventory and tracking at the warehouse level than for following individual parts.

### **4.5 Reverse Engineering**

Reverse engineering includes any techniques that can be used to gather information from an existing part to inform a direct digital manufacturing process. Ideally, this information can be translated into CAD/CAM format.

#### **4.5.1 Coordinate-Measuring Machines**

A coordinate-measuring machine (CMM) is useful for determining precise external dimensions of a complex part. A probe measures the location in 3D space of many representative points on the part surface. The probe can be non-contact (such a laser) or contact (mechanical probe). The accumulated measurements are digitized and form point cloud file that defines the part shape.



**Figure 42. A Table Top CMM (left) and Example of a Point Cloud (Blue) Generated for a Component of a Larger Device. (www.cmmquarterly.com)**

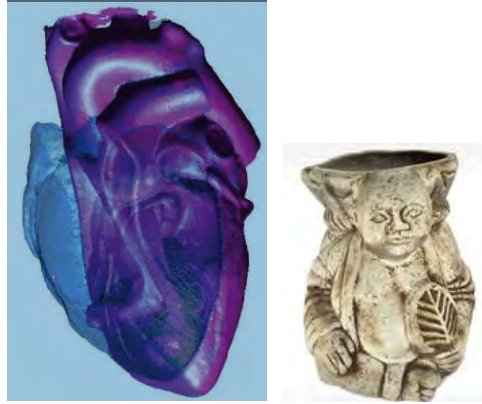
The largest providers of these machines include Helmel, Trimek, Wenzel and Zeiss. The main strengths of CMMs are their high accuracy, ability to measure deep slots and pockets, and, if using a contact probe, they are not influenced by surface optical properties like color or transparency. The drawback of a CMM that uses a contact probe is that it is slow for measuring complex surfaces and can deform soft surfaces, leading to an incorrect measurement. The decision tree for CMM is shown in Figure 43.

Part Size	Material	Part Quantity	Part Cycle Time	MRL Level	Portability	Domestic/Foreign
Small	Metal	Low	Short			Domestic
Medium	Polymer				Large Size/High Power	Foreign
	Ceramic			Production Ready		

**Figure 43. Decision Tree for Coordinate Measuring Machines**

#### 4.5.2 Portable 3D Scanning

A portable 3D scanner projects light on the object of interest, and then detects the reflection with a camera. Multiple scans are taken from different angles and point-cloud data is generated to represent the surface.



**Figure 44. Examples of Complex Objects Modeled with Portable 3D Scanners.** (Left from [www.creaform3d.com](http://www.creaform3d.com) and right from [www.artec3d.com](http://www.artec3d.com).)

The largest providers of these scanners include Artec, Z Corp and Creaform. The main strengths of these scanners are their portability and relatively high speed of data collection. The drawback, is that internal structures cannot be detected. The decision tree for portable 3D scanners is shown in Figure 45.

Part Size	Material	Part Quantity	Part Cycle Time	MRL Level	Portability	Domestic/ Foreign
Small	Metal	Low	Short		Small Size/Low Power	Domestic
Medium	Polymer					Foreign
Large	Ceramic					

**Figure 45. Decision Tree for Portable 3D Scanner**

### 4.5.3 Laser Scanning

A laser scanner reflects laser light from a surface and then generally uses time-of-flight measurements or triangulation to determine the position of points on the surface. As with other optical methods, it generates point-cloud data to represent the surface. Table top and hand held models are common.



**Figure 46. Examples of Complex Objects Measured with Laser Scanners.** ([www.nelpretech.com/reverse\\_engineering.htm](http://www.nelpretech.com/reverse_engineering.htm))

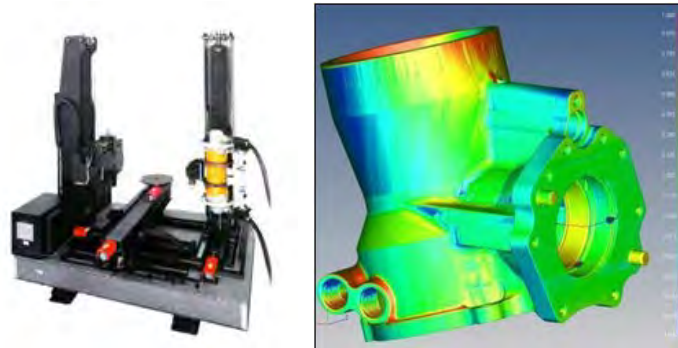
The primary domestic providers of laser scanners include NVision, and Konica Minolta. The main strengths of laser scanners are fast digitization of large volume parts, combined with good accuracy and resolution. The drawbacks are possible performance limitations on colored or transparent surfaces, lasers safety cautions, and inability to detect internal structures. The decision tree for laser scanners is shown in Figure 47.

Part Size	Material	Part Quantity	Part Cycle Time	MRL Level	Portability	Domestic/ Foreign
Small	Metal (low density e.g. Aluminum)		Short		Small Size/Low Power	Domestic
Medium	Polymer	Medium	Medium			
Large	Ceramic	High		Production Ready		

**Figure 47. Decision Tree for Laser Scanners**

#### 4.5.4 Computer Tomography (CT) X-Ray Scanning

Computer Tomography (CT) takes a series of X-ray scans that map cross sectional slices of a part and then assembles them into a 3D map. Internal structures (e.g., channels, voids) can be seen, but this ability is limited by density and part thickness. Thus, it works well on plastics and aluminum, but not denser metals. Scan time per part can be relatively long but information content is high. Output is given in the form of CAD models or blueprints.



**Figure 48. A CT Scanner (left) and Complex Object Measured with the Scanner (right). ([www.nelpretech.com/reverse\\_engineering.htm](http://www.nelpretech.com/reverse_engineering.htm))**

A main provider of CT scanners Nel Pre Tech Corp. The main strength of this technique is the ability to detect and model internal structures of a part. However, there are radiation safety cautions to be observed. The decision tree for CT X-ray scanners is shown in Figure 49.

Part Size	Material	Part Quantity	Part Cycle Time	MRL Level	Portability	Domestic/ Foreign
Small	Metal (low density e.g. Aluminum)	Low			Small Size/Low Power	Domestic
Medium	Polymer	Medium	Medium			
			Long	Production Ready		

Figure 49. Decision Tree for CT-X-Ray Scanning

#### 4.5.5 Industrial Computed Tomography X-Ray Scanning

Similar to CT Scanning described in the previous section, Industrial Computed Tomography takes a series of X-ray scans of part as it is rotated (see Figure 50) rather than cross sections, and then uses digital geometry processing to generate a 3D map. Again, the highlight is the ability to map internal structures along with the outer shape.

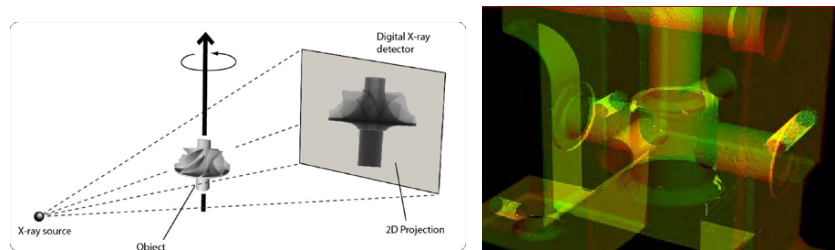


Figure 50. Schematic of Industrial Computed Tomography Technique (left) and Complex Object Imaged in this Way (right). (www.xviewct.com)

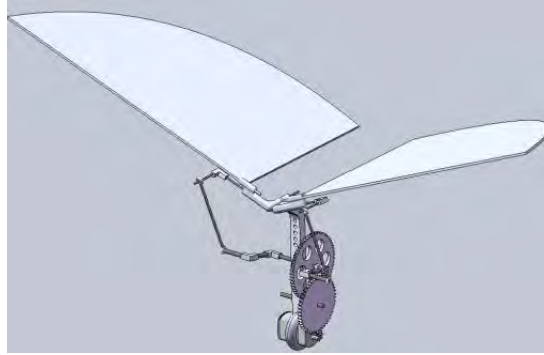
Main providers of computed tomography equipment are XViewCT, Zeiss, North Star and Toshiba. The decision tree for industrial computed tomography X-ray scanning is shown in Figure 51.

Part Size	Material	Part Quantity	Part Cycle Time	MRL Level	Portability	Domestic/ Foreign
Small	Metal	Low	Short			Domestic
Medium	Polymer				Large Size/High Power	Foreign
	Ceramic			Production Ready		

Figure 51. Decision Tree for Industrial Computed Tomography X-Ray Scanning

#### 4.6 CAD/CAM Technologies

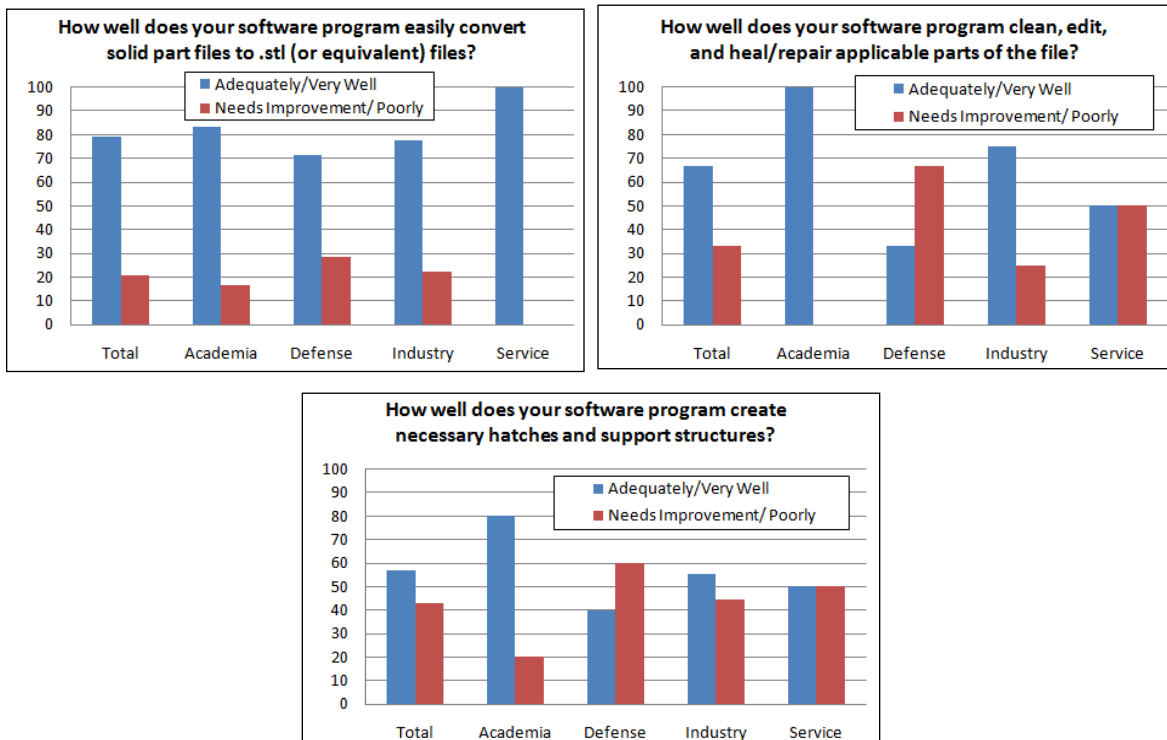
Computer Aided Drafting (CAD) and Computer Aided Machining (CAM) software was developed in the 1980s and has progressed significantly over the last 30 years. Both pieces of software are vital to the DDM industry. CAD software includes off the shelf programs like AutoCAD, Solidworks, and Pro-Engineer. These programs allow for the 3D design of parts. Figure 37 provides an example of a parts designed using Solidworks.



**Figure 52. Example Assembly Design in Solidworks**

After the part has been designed in CAD it needs to go through a post processor to be readied for input into the DDM machine. The post processing software is being produced by a number of developers including Tesis, Materialise, and Able. The output of the post processing software is a common .stl file type. The .stl file format provides all the instructions required to the DDM equipment for fabrication of the part. Each machine platform has proprietary software which loads the .stl file and allows for a variety of part processing parameter manipulation.

Figure 53 outlines the survey responses regarding software.



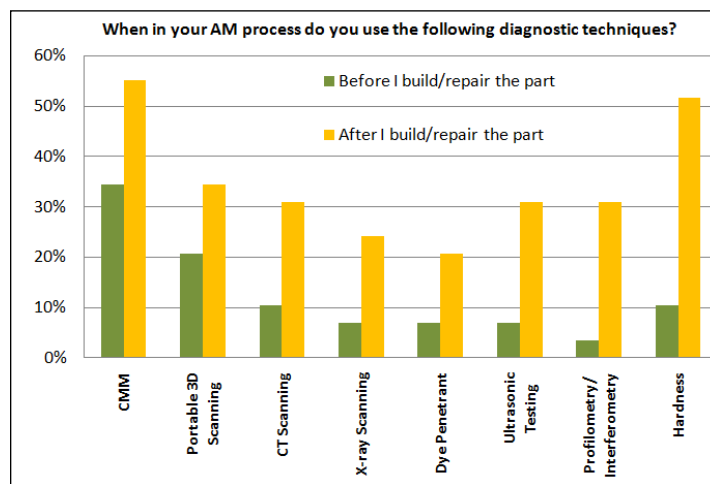
**Figure 53. Online Survey Responses for DDM Software**



Converting solid part files to .stl files was the software task that respondents felt their software programs performed most adequately. Conversely, with the exception of respondents from Academia, there were almost as many people who were dissatisfied with their software “creating necessary hatches and support structures” as there were who were satisfied. Overall it appears that respondents in Academia were somewhat more satisfied than the total average with the performance of their software programs and respondents in Defense were somewhat less satisfied.

#### 4.7 Diagnostics

After part fabrication is complete diagnostics will be required to verify part integrity. The diagnostics will include both geometrical inspection and scanning the part for internal defects. Through the online survey MLPC asked participants to provide feedback on the diagnostic tools used in DDM. The results are shown in Figure 54.



**Figure 54. Online Survey Results for Diagnostics Used in DDM**

Not surprisingly, the proportion of respondents who use a certain diagnostic technology tends to increase as the cost and time associated with performing the diagnostic decreases. So, it's expected that more people use CMM and hardness testing than CT Scanning. However it's interesting to note that while Surface Roughness was ranked among the highest aspects of AM needing improvement, only ~30% of respondents report using Profilometry/Interferometry as a diagnostic. This might indicate that the surface roughness of the AM parts is high enough that the users must perform additional machining and/or polishing anyway, so they do not bother quantifying the initial roughness.

The geometrical inspection would be completed using a coordinate measuring machine (CMM) as shown earlier in Figure 42. CMM inspection provides high accuracy measurement ( $\pm 0.00025''$ ) using a contact probe method of measurements. Companies producing this equipment include Wenzel, Zeiss, and Trimek.

Another method of measurement includes a non-contact method of laser scanning. Laser scanning can be used similar to the CMM as shown in Figure 55. The accuracy of a laser scanning system is ( $\pm 0.0002''$ ).



**Figure 55. Laser Scanning Equipment**

Key players in the manufacture of laser scanning equipment include NVision and LaserDesign. The final technology that was explored for part diagnostics is computer tomography x-ray scanning. This technology is important to verifying the absence of defects internal to the part. The technology works by scanning the part with a series of x-rays and reconstructing a 3D map of the part. The downside of this technology is the relatively long scan times (2-3 hours for a small part), but the amount of information gained through this process is important for parts used in critical applications as shown in Figure 56.



**Figure 56. Industrial CT Scanning of Aluminum Cast Part ([www.toshiba-itc.com](http://www.toshiba-itc.com))**

This technology can be used for both part integrity inspection and reverse engineering. Leading suppliers of equipment in this industry include Zeiss and Toshiba.

## 5.0 CONCLUSIONS

Each technology reviewed across the DDM industry had opportunities for further development. These areas for continued development have been identified below.

### **Reverse Engineering/Diagnostics**

Reverse Engineering and Diagnostics were combined because of the similarity in application and equipment. Technologies that are used in this area are listed below and are relatively mature.

**MRL:** > 6 – The MRL level was placed at greater than 6 because these technologies are routinely used today across many industries.

#### **Development Areas:**

- Reduce Cycle Time - Current cycle time limitations on CT scanning can be hours per part. Reducing this cycle time is important to reduce the turnaround time on part production.
- 3D scanner – This technology is limited to line of sight geometry. If the part has interior geometry there is no way to capture this information.
- Capital Cost – The cost of 3D, CT, and X-ray technology is relatively high with entry level systems starting at \$15K and high end systems going for up to \$400k. Reducing the cost of this capital equipment is important to wider adoption of the technology.
- Large Part Scanning – As the size of part increases the resolution of the scan decreases. Improving the resolution of scanning larger components is important to production of these parts using DDM technologies.

### **CAD/CAM**

**MRL:** > 6 – The MRL level was placed at greater than 6 because CAD/CAM is used routinely across many industries.

#### **Development Areas:**

- Hatches and Supports – There is not a wide understanding on the design side how to incorporate support structures and hatches into the CAD model. This requires more knowledge and training of the process.

### **Hybrid Manufacturing**

**MRL:** 4 – 6 – The MRL level was rated lower because this technology is still in the development stage and is not widely used in industry.

#### **Development Areas:**

- Multi-material processing – This is significant area of development for DDM. The ability to combine materials during processing or create graded material structures opens up many new applications.
- Complete integration of additive/subtractive – Much work has occurred in Europe to combine these technologies onto one platform. This integration would enable complete part processing in one machine.

## Subtractive Manufacturing

**MRL:** > 6 – The MRL level was rated higher because most of this technology is mature.

### Development Areas:

- Femtosecond Laser Micromachining – Although most of this technology space is mature there are some areas where further development could advance DDM capability. Femtosecond Laser Micromachining enables a wide array of materials to be processed without the concern of consumables.

## Additive Manufacturing

**MRL:** 4-6 – The MRL level was rated lower because of the continued development occurring in this technology space.

MLPC - 2011	Navy DDM 2010	EWI AM Consortium 2010	AFRL AM Workshop 2009	Roadmap for AM 2009 – Bourell, Leu, Rosen
Reduced Surface Roughness- Reduce to eliminate post processing	Accelerated qualification and certification methods	Material Property Database	Material Property Database	Design – new CAD modeling concepts, methods, multi-scale modeling.
Build Speed. Increase by 2-3X	Process modeling – accurate and predictive for microstructure and matl. properties	In process monitoring and control, low cost NDE	New Affordable Materials designed specifically for AM	Process Modeling and Control – predictive design tools, closed loop adaptive controls
In-process monitoring. Diagnose part as being built.	Post fabrication to enhance fatigue properties – match wrought materials	Distortion control – residual stress and distortion control	Process Development	Materials, Processes, and Machines – fundamental understanding of physics, open architecture equipment, screen for materials
Raw Material Variety. More selection, established material properties.	Part to part and machine to machine repeatability	Equipment development – faster build rate and increased size	Process Modeling	Education – develop university courses, materials, and curricula, training programs for technicians
Maximum Part Size. Increase volumetric capacity of machines	Closed loop control – process monitoring – real time NDE	Affordable materials, new material evaluation	Real Time Process Control	Development and Community – reduce machine, material, and servicing cost, standards for manuf.
Reduce Cost of Capital and Material	Technology Fusion – laser scanning, database, design tools	Standards and specifications	Non-Destructive Inspection	National Testbed Center
Process Modeling	Structural design and analysis tools	Process Modeling and Optimization	Design Rules & Tools	

**Figure 57. Recommended Development Areas from Conferences on Additive Manufacturing Over the Past 2 Years**

The chart shows the recommended development areas from conferences on additive manufacturing over the past 2 years. There are common themes across each conference with regards to developments required to move additive manufacturing forward.

### Development Areas:

- Process
  - Process Control – Develop methods for in process monitoring.
  - Process Modeling – Develop predictive modeling to assist designers, engineers, scientist, and users.

- Process Limitations – Define the build rate, surface roughness, and residual stress for each process and a roadmap for increasing the build rate, part size, and reducing residual stress of each technology.
- Process Sequence – Define the real process sequence including pre and post process requirements.
- Equipment
  - Machine Qualification – Define a standard for machine qualification. Complete a baseline on each process machine and roadmap for improving.
- Materials
  - Material Property Database – Define a method for creating such a database
  - AM Materials Development – Create a process for AM materials testing and qualification.
- Design
  - Education – Training for designers on process limitations and best practices
  - Paradigm Shift – Roadmap for changing the design paradigm to include the manufacturing flexibility of AM processes.
- Customer
  - Define a protocol for qualification and testing of AM parts.

### **Part Information Data Storage**

**MRL:** >6 – This technology was rated higher because there are existing off the shelf process for incorporating complex data storage into unique identifier codes.

### **Development Areas:**

- Format of Data – Customer needs to determine the type of part information to be stored.
- Database – Customer needs to determine the format of a database for tracking part information.

## 6.0 REFERENCES

Gibson, Ian, David W. Rosen, and Brent ., Stucker. *Additive Manufacturing Technologies Rapid Prototyping to Direct Digital Manufacturing*. New York: Springer, 2010. Print.

Wohlers, Terry T. *Wohlers Report 2011: Additive Manufacturing and 3D Printing State of the Industry Annual Worldwide Progress Report*. Fort Collins, Col.: Wohlers Associates, 2011. Print.

Ott M., Zaeh F. *Multi-Material Processing in Additive Manufacturing*, Institute for Machine Tools and Industrial Management

Frazier, William E. *Direct Digital Manufacturing of Metallic Components; Vision and Roapmap* Naval Air Systems Command, September 2010.

*Additive Manufacturing Metals Workshop*, October 20-21, 2009 Dayton, Ohio.

*Additive Manufacturing Consortium*, EWI, December 2010, Columbus, Ohio

Bourell, David L., Leu, Ming C., Rosen, David W. *Roadmap for Additive Manufacturing*, University of Texas at Austin, 2009

## APPENDIX A

### Direct Digital Manufacturing Survey

On May 13 MLPC sent 125 invitations to Additive Manufacturing users in academia, defense, industry, and service to participate in an electronic survey designed to gather data about potential areas for improvement in the field. The survey consisted of three parts:

- PART ONE: How the respondent uses AM
  - In which field does the respondent work?
  - What is the respondent's primary use for AM?
- PART TWO: Prioritize aspects of a particular AM technology that may need improvement
  - Aspects such as build speed, surface finish, etc. were listed for each of 10 AM technologies (DMLS, DMD, etc.) based on MLPC's previous research and respondents were asked to rank them in order of importance
  - Respondents were also asked to choose which of several aspects such as equipment purchase and raw material cost are most/least expensive to run their AM process
- PART THREE: Inspection/Diagnostic and Software
  - Respondents were asked to select which mainstream inspection and diagnostic methods they use before and after they build a part using AM
  - Respondents were asked to state how satisfied they were with the ability of their AM software programs to perform various tasks

#### PART ONE RESULTS:

Forty-one responses were gathered over 4 weeks, representing a variety of users in different fields, with different uses for AM. Figure 1a shows the respondents' demographics, which were gathered in Part 1 of the survey.

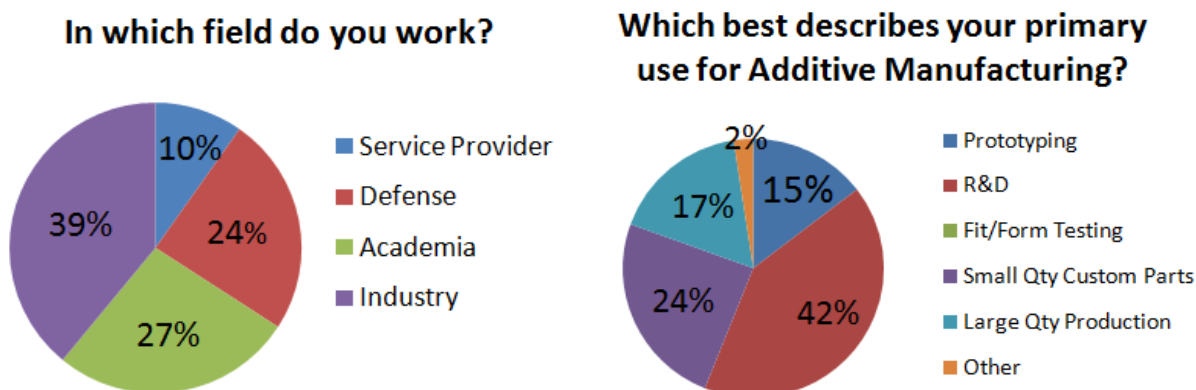


Figure 1a: Part 1 Results

## PART TWO RESULTS

For each of the ten AM technologies covered in the survey, MLPC chose several aspects that have been identified by several users of the technology to be in need of improvement.

Preliminary feedback from these users suggests that if these aspects are improved, the AM technologies will become more amenable to wider spread use across the manufacturing industry. In this survey respondents were asked to rank them in the order in which they would like to see emphasis placed on development. To illustrate how this appears in the survey, Figure 2a shows a screen shot of one particular response given by a user of Selective Laser Sintering (Polymers) to Part Two, Question 1 of the survey.

1. The following aspects of Selective Laser Sintering (Polymers) have been identified as areas needing potential improvement/development. Please rank them in the order in which you'd like to see emphasis placed on development.									
	Priority 1 (1)	Priority 2 (2)	Priority 3 (3)	Priority 4 (4)	Priority 5 (5)	Priority 6 (6)	Priority 7 (7)	Priority 8 (8)	Priority 9 (9)
Build Speed								X	
Maximum Part Size							X		
Minimum Feature Size		X							
Raw Material Variety	X								
Amount of Post Processing Required						X			
Powder Recycling Methods/Standards			X						
Porosity/Finished Part Strength				X					
In-Process Monitoring					X				
Other?									X
<i>Please Specify Other:</i>									

**Figure 2a: Example of a response to Part Two, Question 1**

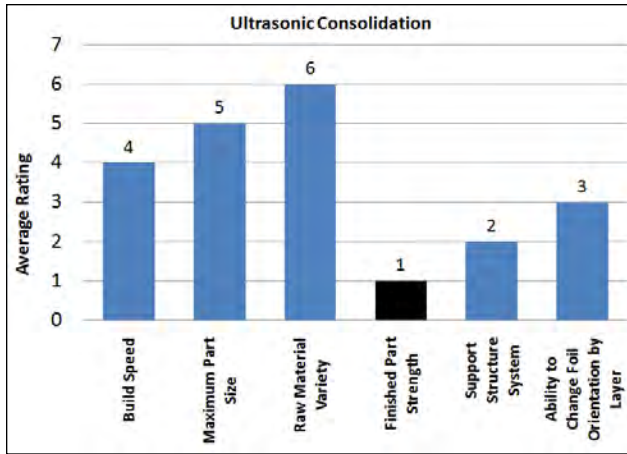
Note that respondents only provided feedback for AM technologies they use. The survey was designed to allow a person to skip the technologies for which they do not have experience. Some respondents provided feedback for just one of the ten AM technologies and some responded to three, four, or even six of the ten.

To compare the relative importance of the different aspects of the AM technology, an “average rating” was assigned to each. For each aspect, the number of responses for each priority was multiplied by the weight of the priority and divided by the total number of responses. For example, if three respondents ranked build speed as priority 1, two ranked it as priority 4, and 1 ranked it as priority 8, then the average rating for build speed is:

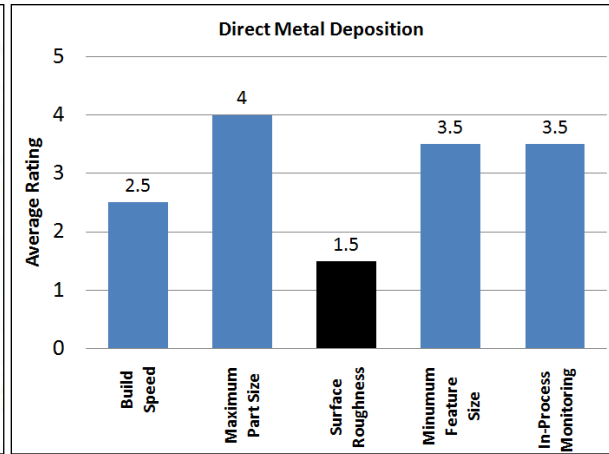
$$\{(3 \times 1)+(2 \times 4)+(1 \times 8)\} / 6 = 3.17$$

Therefore a lower average rating implies a higher need for emphasis on improvement/development for that aspect. Figures 3a-12a show the average ratings for each of the aspects ranked for the ten AM technologies. The aspect with the greatest need for improvement/development is shown in black for each technology.

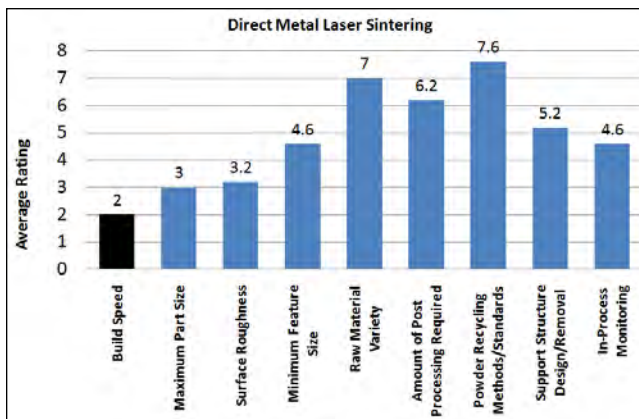




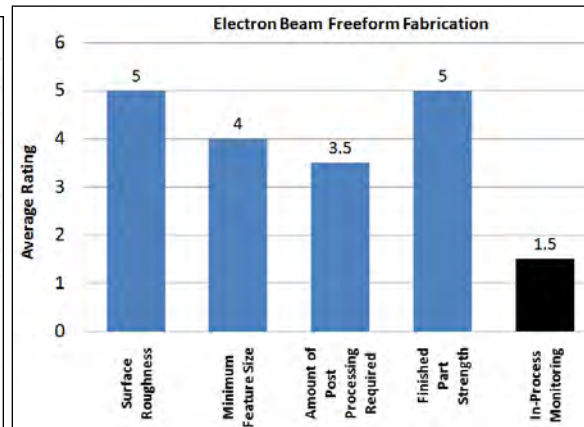
**Figure 3a: Ultrasonic Consolidation**



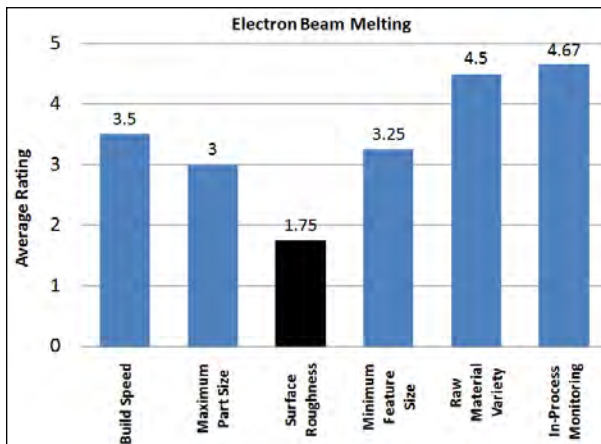
**Figure 4a: Direct Metal Deposition**



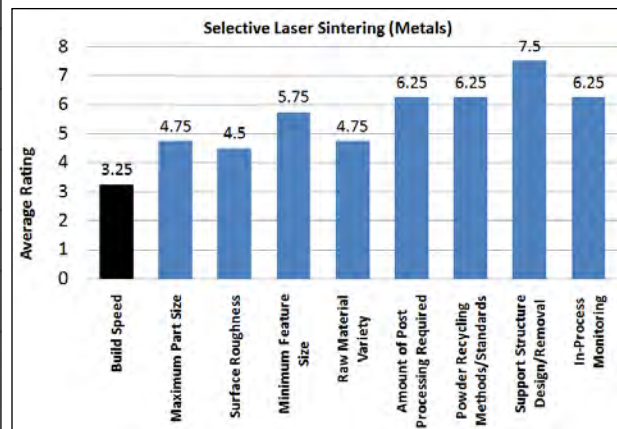
**Figure 5a: Direct Metal Laser Sintering**



**Figure 6a: Electron Beam Freeform Fabrication**



**Figure 7a: Electron Beam Mel**



**Figure 8a: Selective Laser Sintering (Metals)**

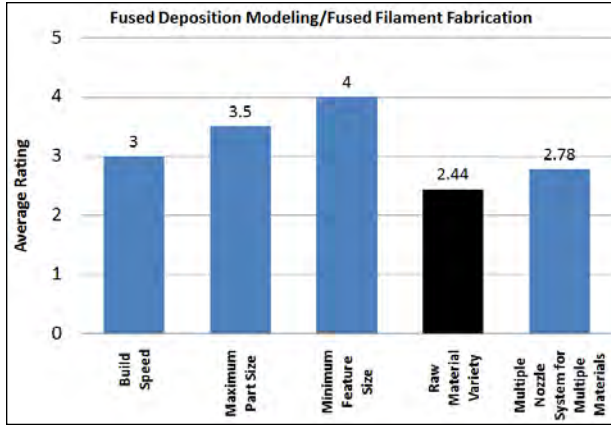


Figure 9a: Fused Deposition Modeling/Fused Filament Fabrication

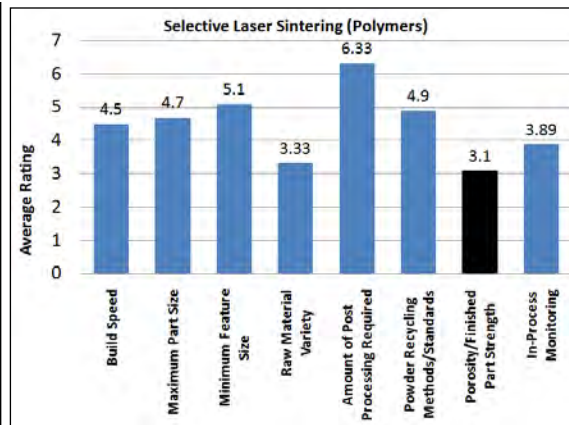


Figure 10a: Selective Laser Sintering (Polymers)

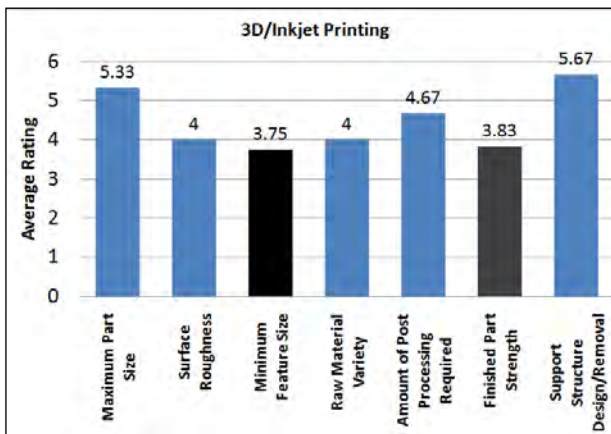


Figure 11a: 3D/Inkjet Printing

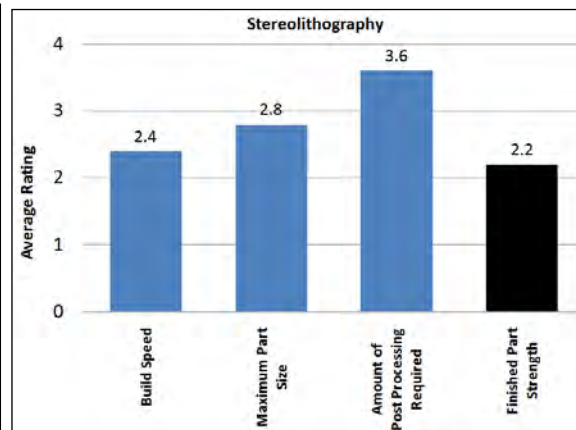


Figure: 12a: Stereolithography

After reviewing Figures 3-8 the following results are noted about AM technologies that **build metal parts**:

- Build Speed and Surface Roughness were each ranked in the top 3 most important aspects for improvement/development for four of the six AM technologies that build metal parts. In fact, they were ranked most important in two technologies each.
- The results for Maximum Part Size were split. This aspect was ranked in the top three priorities for three of the six technologies, but was not of great importance to the respondents of the other three.
- Except for Electron Beam Melting, in which it was ranked as the most important aspect for development, In-Process Monitoring was ranked in the bottom half for the other technologies.
- Surprisingly, respondents did not seem to place Raw Material Variety very high on their list of priorities of aspects needing improvement.

After reviewing Figures 9a-12a the following results are noted about AM technologies that **build polymer parts**:

- Three out of the four AM technologies that build polymer parts (SLA, SLS Polymers, 3D/Inkjet Printing, and FDM/FFF) showed Finished Part Strength as being either the first- or second-most important aspect for improvement/development.
- Raw Material Variety and Build Speed were other aspects that respondents generally seemed to place emphasis on for improvement/development. These aspects usually fell in the top half of priorities for the different technologies.
- On the other hand, Maximum Part Size and Amount of Post Processing Required did not generally seem to be of major concern to the respondents. Neither of these aspects fell in the top 50% of choices for needing improvement/development.

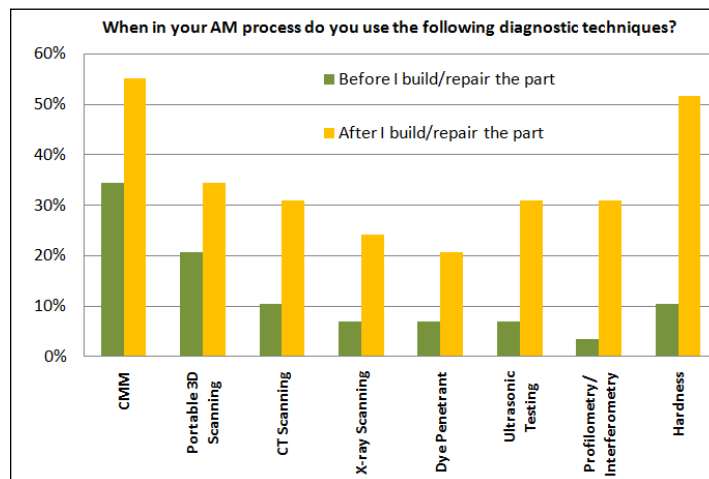
The second question in Part Two addressed the expenses associated with running the AM process. The four expenses that respondents were asked to rank highest to lowest included:

- Equipment Purchase
- System Maintenance/Operation
- Raw Material
- Post Processing (curing, annealing, finishing, machining, etc.)

In each all 10 of the technologies, Equipment Purchase was ranked “most expensive,” Post Processing was ranked “least expensive,” and System Maintenance/Operation and Raw Material fell in between, ranked equally expensive.

### PART THREE RESULTS

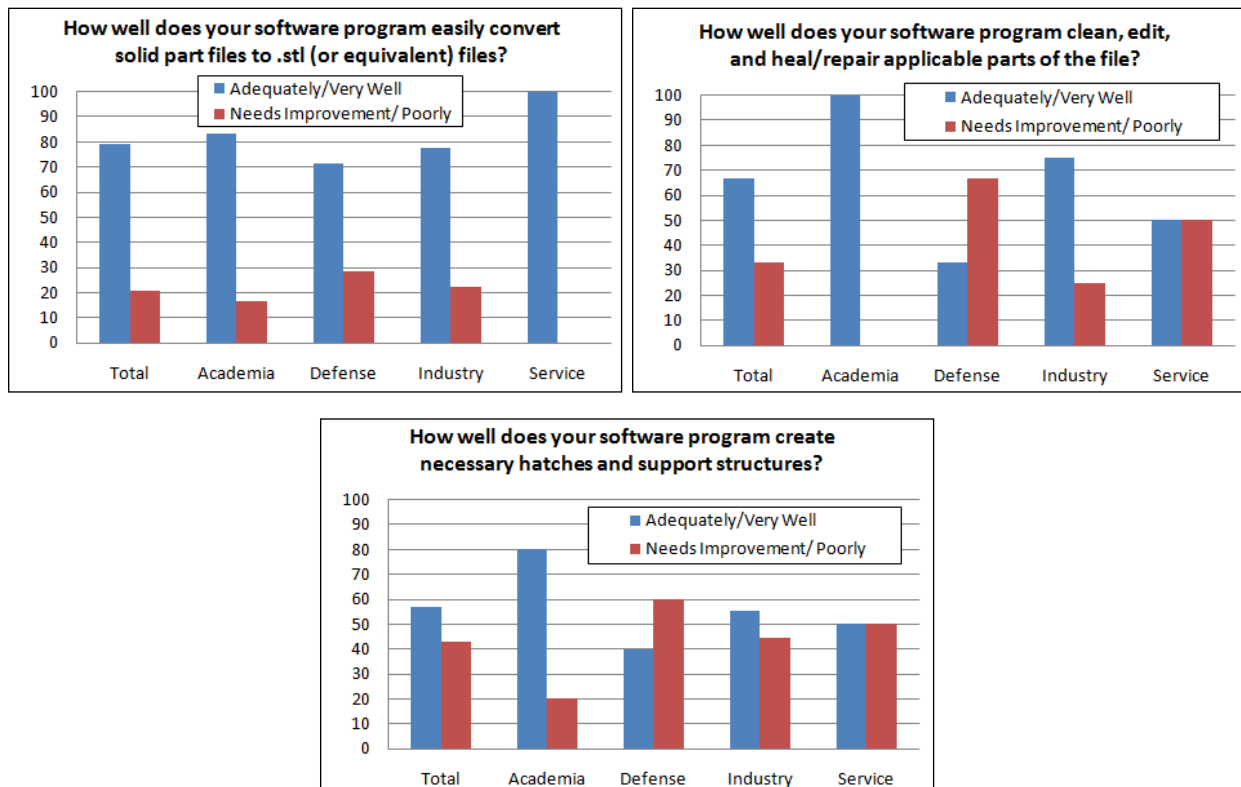
The first question in Part Three asked respondents to select which of eight mainstream inspection/diagnostic techniques they use during their process. Figure 13a shows the percentage of the respondents who use each.



**Figure 13a: Part Three Question 1 results**

Not surprisingly, the proportion of respondents who use a certain diagnostic technology tends to increase as the cost and time associated with performing the diagnostic decreases. So, it's expected that more people use CMM and hardness testing than CT Scanning. However it's interesting to note that while Surface Roughness was ranked among the highest aspects of AM needing improvement, only ~30% of respondents report using Profilometry/Interferometry as a diagnostic. This might indicate that the surface roughness of the AM parts is high enough that the users must perform additional machining and/or polishing anyway, so they do not bother quantifying the initial roughness.

The second question asked respondents to state how well their software performs various tasks. Figures 14 summarize the responses.



**Figure 14a: Results of Part Three Question 2**

Converting solid part files to .stl files was the software task that respondents felt their software programs performed most adequately. Conversely, with the exception of respondents from Academia, there were almost as many people who were dissatisfied with their software “creating necessary hatches and support structures” as there were who were satisfied. Overall it appears that respondents in Academia were somewhat more satisfied than the total average with the performance of their software programs and respondents in Defense were somewhat less satisfied.

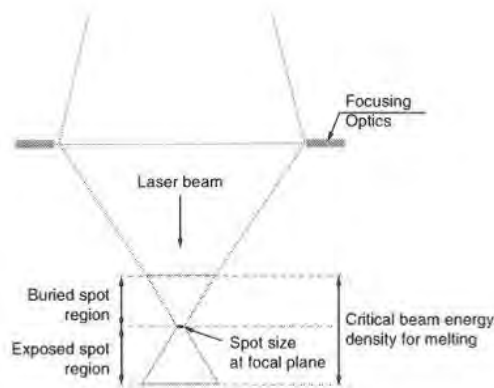
## APPENDIX B

### Book Summary

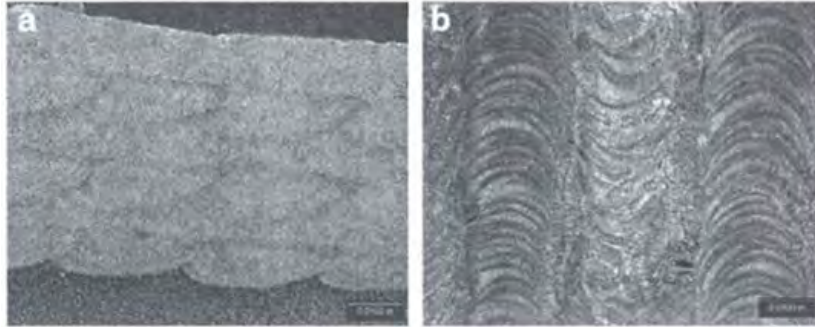
Additive Manufacturing Technologies by Ian Gibson, Brent Stucker, and David W. Rosen

#### Beam Deposition (BD) Process

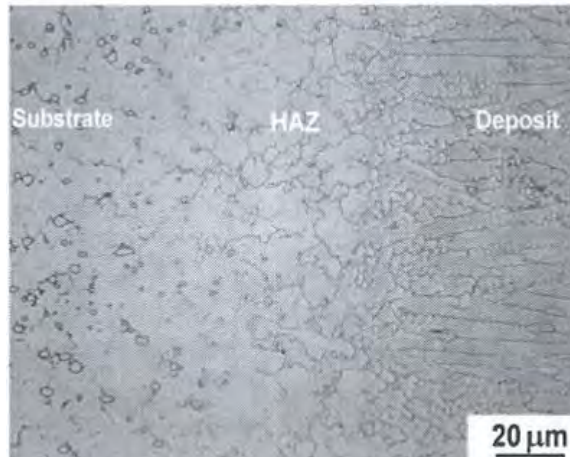
- Creation of parts by melting and depositing material from powder or wire **feedstock through a nozzle** using a beam (laser or electron) as the energy source
- Encompasses Laser Engineered Net Shaping (LENS), Directed Light Fabrication (DLF), Direct Metal Deposition (DMD), 3D Laser Cladding, Laser Freeform Fabrication (LFF), Laser Consolidation, Electron Beam Freeform Fabrication (EBF3), and others
- Deposition Process
  - Beam scans across substrate/previous layer forming a melt pool, into which powder or wire is fed, causing it to melt as well and build up the next layer
  - Parameters:
    - beam power
      - Nd-YAG systems usually have higher absorptivity in materials and therefore use lower powers
      - CO<sub>2</sub>/fiber lasers (cheaper) usually have lower absorptivity in materials so higher powers are needed to compensate, **resulting in larger heat affected zones** and larger overall heat input into the substrate
    - scan speed
      - affects melt-pool characteristics and deposit thickness
      - melt pool usually 0.25-1.0 mm in diameter, 0.1-0.5 mm deep
      - resulting cooling rates between 1,000-5,000°C/s
    - track overlap
      - usually ~25%
    - z-offset value
      - usually 0.25-0.5 mm
      - If power and scan speed are incapable of producing a deposit thickness of at least as thick as the z-offset subsequent layers will become thinner and thinner, eventually self-terminating:



- Process Advantages over extrusion-based AM:
  - No swelling or overfeeding problems
  - The melt pool automatically levels the surface of the previous layer. The melt pool will fill in any corrugation or trenches from the previous layer.
- Microstructure
  - “unparalleled control” when compared with other AM processes
  - Can vary between layers and even within layers depending on user’s needs

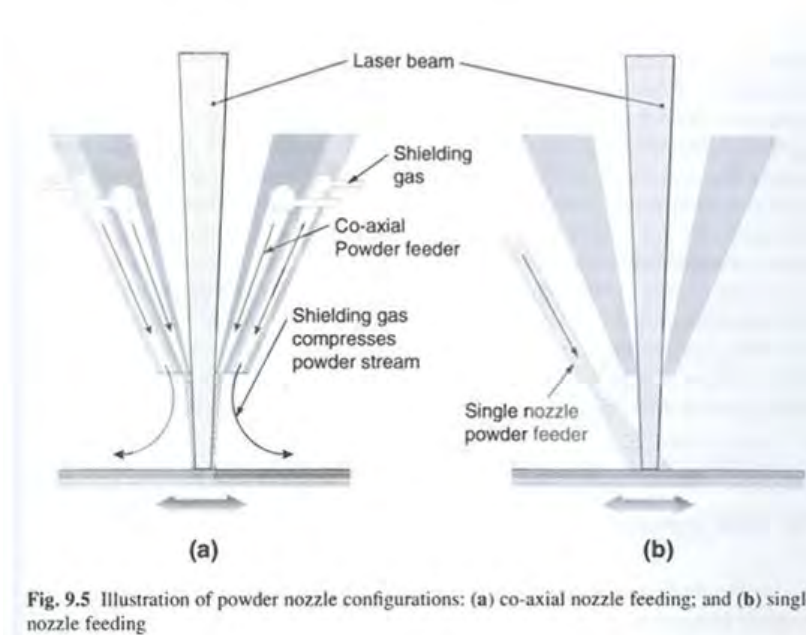


- The high cooling rates and large thermal gradients can produce nonequilibrium grain structures that are not possible using traditional processing
- Preferential grain growth (and therefore anisotropy) and residual stress buildup can be eliminated by alternating the scanning direction after each layer
- Resulting fine grain structures provide superior strengths but poor ductility. Ductility may be recovered with heat treatment
- Typical layered microstructure with fine grains and thin HAZ shown below (CoCrMo/CoCrMo)

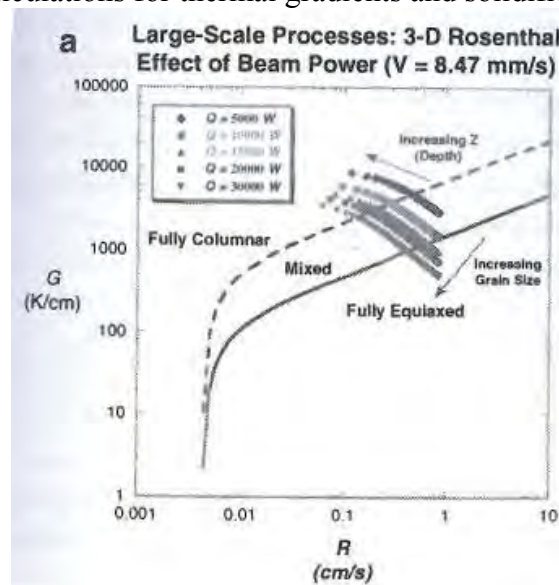


- BD is capable of producing directionally solidified and single crystal structures
- Nozzle configurations for Powder
  - Coaxial feeding
    - Higher capture efficiency
    - Focusing shielding gas protects the melt pool from oxidation
  - 4-nozzle feeding
    - More consistency in build height, allows more control over combinations of thick and thin regions
  - Single nozzle feeding

- Simple, low cost
- Ability to deposit material in tight locations



- Process Monitoring
  - Unlike SLA, FDM, and SLS which come pre-programmed with optimized process parameters for materials, Beam Deposition processes are more “flexible” and thus users must develop their own parameters
  - Because of this, closed-loop process monitoring is more developed in these systems
    - Microstructures are predicted using process maps, developed using calculations for thermal gradients and solidification rates



- These maps predict the type of BD system needed for a particular microstructure. For example, a low-powered BD system could not produce equiaxed Ti-6-4 microstructures.

- Most Optomec (USA) LENS systems don't use closed-loop feedback but they now offer a 5-axis LENS system that deposits from any orientation. The system monitors build height and melt pool area and dynamically changes process parameters to maintain constant deposit characteristics
    - Most POM (USA) DMD machines do have integrated closed-loop controls, which consist of 3 CCD cameras to provide optical information about the melt pool. Process parameters including powder flow, laser power, and scan speed are adjusted accordingly
- Multiple materials
  - BD can be used to deposit just a few layers of a hard material on the surface of an existing part for coating purposes. The z-step height is simply adjusted to a large distance to ensure:
    - Sharp transition from A to B. Minimal mixing of the substrate and the deposited material is needed to prevent undesirable intermetallic formation. So if the focal plane of the laser is set above the surface of the substrate the resulting melt pool will consist mostly of the deposited power
    - The large z-step will ensure that the layer deposition will self-terminate after a few layers, as described above
  - Formation of brittle phases when combining dissimilar materials can also be suppressed when an interlayer of an appropriate material is used
    - Example: when depositing CoCrMo on Ta, a thin Zr interlayer deposited using low laser power and high scan rates will prevent subsequent cracking and delamination
- Developments:
  - Hybrid Processes:
    - Controlled Metal Buildup (CMB) developed by Fraunhofer Institute integrates additive and subtractive manufacturing. A diode laser builds a layer using wire feedstock, then a high-speed milling cutter slices the layer to the correct contour.
    - Electron Beam Freeform Fabrication fits here?
- Limitations:
  - Poor resolution and surface finish
    - Accuracy better than 0.25mm hard to achieve
    - Surface roughness greater than 25 um
  - Slow Build speed
  - Complex geometries difficult, require support structures



## APPENDIX C

### Additive Manufacturing Workshop – Wright State University

Bill Baron – AFRL/RBSA

[william.baron@wpafb.af.mil](mailto:william.baron@wpafb.af.mil)

Multifunctional Airframe Concepts with Structurally Integrated Electronics

- For imbedded sensors redundancies are put in to accommodate problems, breaks, etc.
- Integrated system health management (ISHM)
- Putting tens of thousands of sensors onto aircraft
- Fly by feel concept – what bats and birds do; sensors on aircraft wing feed back information to pilot as a tactile array. <http://www.d.umn.edu/~cprince/PubRes/FbF/>
- Direct write and thin films on composite structures
- Laser transfer of semiconductors
- Direct write enables multifunctional structures
- Coaxial capacitor concept – can carry a load and not crack
- Direct write is durable, but can crack; use encapsulation to prevent problems
- Polymer work – how does this fit in with Nanospense and the powders that Art is developing?

Paul Clem – Sandia

- Discussed nanoparticle inks and direct write
- Printed a strain gauge; what about micromachining a strain gauge – something to look into
- Also showed a metal foil strain gauge
- Referred to patent no. 6027326 – “robocast”; new type of rapid prototyping from a slurry; Sandia is patent holder
- Showed aerosol micro spray for Cu and Ag; 10-25 micron lines
- Ag ink used 8 nm Ag particles
- Showed binding of Ag 25 nm particles using STEM at Univ. Texas, Austin. Outstanding images
- Showed laser sintering of strain gauges made with 8 nm Ag ink; still seems like a micromachining application
- Made Pt/Au thermocouple
- Made a “micro “ hot plate – printed micro heaters; used Pt – need to see what is on SNLA website about this
- LiFePO<sub>4</sub> batteries; LiFePO<sub>4</sub>/graphite/PVDF also;
- [pgclem@sandia.gov](mailto:pgclem@sandia.gov)

### Jim Sears

- Discussed MicroFab Technologies, Inc. – digital microdispensing technology; inkjet
- Sintering of deposited inks – need to go from 30% dense to 100% dense
- Laser (2800 J/cm<sup>2</sup>) – didn't specify
- Furnace – 400 C
- Photonic sintering – Xe flashlamp
- Using Time Domain Reflectometry for measuring composite health – how does this differ from IDT sensor work? Does it compete and if so how good is it?
- Uses an n-Script system

### Dave Keicher – Optomec

- M3D process
- Aerosol spray
- 5-axis EMI shielding
- 10 micron lines
- ManTech funded
- Looking at the display market

### Jeff Brogan – MesoScribe

- MesoPlasma<sup>TM</sup> direct write processing
- Plasma spraying but with less resolution than Optomec; 250 micron lines about 25 micron thick
- Write on carrier film that is compatible with composite
- Showed turbine sensors, thermocouples; fabricated a heat flux sensor using ps laser
- Working Scram jet combustor monitoring
- Fabricating strain gauges
- Passive – wireless graphite epoxy
- Heaters – NiCr – used for deicing and sensing
- Discussion on multifunctional structures
- Discussion about structural energy storage in air vehicles – this will be important for MAV
- Now has FAA approved sensors on aircraft
- Working on conformal and integrated antennas
- [jbrogan@mesoscribe.com](mailto:jbrogan@mesoscribe.com)

### Brad Barnett – Odysian

- Smart structures, multifunctional structures, structural subsystem integration – all important for UAV and MAV
- Enabling technologies; wireless, thin film, flex circuits, composites, direct write

- Had a thin film igniter for thermal battery; must replace hot wire ignition; wonder what the advantage is?
- Direct write for MAV – do we need to be working towards this? Should WSU be exploring this technology? AFRL already is – RX (Max, Brandon) is; what about RB?
- The structure becomes the circuit board; integration beams redundancy in case of circuit failure
- Direct write can eliminate cable ties, black boxes, etc. on aircraft and save weight
- Direct write on MAV will make more room for payload
- Micro satellites – want plug and play
- Looking for an all-electric or a more electric air vehicle
- Discussed conformal load bearing antenna – this would be good for MAV.
- Showed smart piping for a chemical laser – was it the COIL? Didn't say.
- Talus X-1 RPV – structural battery in wing spar
- Argus RPV – composite antenna structure
- 3De (trademark) Version 1 – can't remember what this is

Joe Kunz – SI2

- Discussed direct write and laser transfer
- Need to integrate with legacy systems
- System Integrated Design and Manufacturing (SIDM)
- Discuss how this combines multiple technologies. Good point. Manufacturing of today will need to do just that.

Dr. Tom Starr – University of KY, Louisville

- Discussed 316L (Concept Laser M1), 17-4 PH (EOS M270), and 15-5 PH
  - o <http://www.estechology.co.uk/concept.html>
  - o <http://www.eos.info/en/products/systems-equipment/metal-laser-sintering-systems.html>
- 17-4 does not transform to martensite on cooling
- A 650 C heat treat does not result in phase conformation
- A 788C heat treat enables martensite transformation
- Discussed strain induced transition from austenetic to martensitic

Eli Liechty – RQM – Partnered with Morris Technologies and MicroTech Finishing

[Commercial Benefits of Metals Additive Manufacturing for Aerospace ...](#)

Industry leader in validating production applications. ▪ Partnered with Morris Technologies and MicroTek Finishing. **Additive Manufacturing** Center of ...

[www.midwestsampe.org/content/files/.../Metals%20Liechty.pdf...](http://www.midwestsampe.org/content/files/.../Metals%20Liechty.pdf...)

- Working in aerospace and medical

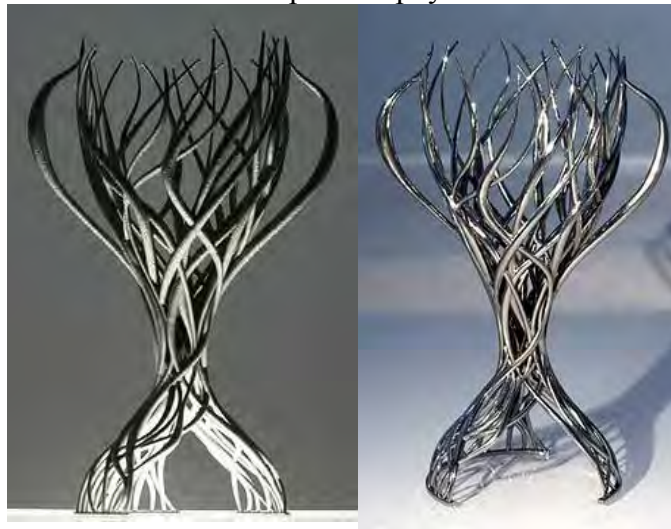
- Primary uses: complex assemblies, design to process, and direct replacement parts
- Complex assemblies – supply chain simplification
- Design to process – technical and competitive advantages
- Direct replacement – faster to market/reduced cost
- Making new alloys
- Standard curves for laser melted parts need to be done; who is going to do this? EWI and the AMC?
- There is a need for more controls – chamber controls, data reporting, melt pool monitoring, closed-loop? How many times has closed loop been tried?
- Broader markets
  - o Aerospace is leading the way
  - o Heat exchanger in UK for a race car
  - o Finger implant – designed to enhance bone growth thru holes in the implant
- Feels the industry will increase exponentially
  - o Need more power
  - o Double in size in the next 24 months

#### MicroTek

- Finishing of DMD parts
- BESTinCLASS SA – Switzerland for finishing
  - o A micromachining process

Example of finishing – finishing time was 30 hours.

Sample "Trophy"



*"Before": as built on EOSINT M 270.*

*"After": polishing by Best-In Class (MMP), duration: 30h*

"Trophy" designed by Lionel T Dean (FutureFactories), produced by 3T RPD on an EOSINT M 270, post-processing by Best-In-Class (Micro Machining Process).

- Application areas
  - o Tooling
  - o Aerospace
  - o Medical
  - o Luxury
- Uses small amounts of material and maintains geometry
- There is primary roughness and secondary roughness; can adjust to the different layers of roughness
- Claimed they were reducing surface energy. How? Did they measure it?
- What about laser polishing? Fraunhofer did this several years ago.
  - o Laser polishing:
    - [http://www.ilt.fraunhofer.de/eng/ilt/pdf/eng/products/HZ\\_Laser\\_Polishing\\_Of\\_Titanium.pdf](http://www.ilt.fraunhofer.de/eng/ilt/pdf/eng/products/HZ_Laser_Polishing_Of_Titanium.pdf)
    - [http://www.cuimrc.cf.ac.uk/sites/www.cuimrc.cf.ac.uk/files/4M-9-Laser%20polishing08\\_02.pdf](http://www.cuimrc.cf.ac.uk/sites/www.cuimrc.cf.ac.uk/files/4M-9-Laser%20polishing08_02.pdf)
    - <http://www.ilt.fraunhofer.de/eng/101641.html>
    - [http://www.engineerlive.com/Design-Engineer/Time\\_Compression/Laser\\_polishing\\_is\\_faster\\_than\\_hand\\_polishing/22194/](http://www.engineerlive.com/Design-Engineer/Time_Compression/Laser_polishing_is_faster_than_hand_polishing/22194/)
- Can do PEEK
  - o 150 F processing temperature
- Cannot finish internals except for line of site with an aspect ratio of no more than 10:1; no 90 degree turns
- Tools are made by BESTinCLASS
- Can do tools for optics
- Technique follows the form of the part

Mary Kinsella and Howard Sizek – reviewed workshop at WPAFB in October 2009

- Additive manufacturing materials database
  - o No funding available for database
  - o Collaboration means sharing data
  - o Rely on modeling
- New affordable materials
  - o High temperature polymers with C fiber filler
  - o Meet aerospace requirements – EMI and ESD
  - o Polymers by SLS show more anisotropy
- Process development
  - o Distortion control
- Process modeling

- Real-time process control
  - o Funded a SBIR on e-beam
- NDE
- Design Rules and Tools
  - o Need to understand capabilities
  - o Accelerate additive manufacturing into the design space
- Computational methods will be critical
  - o See International Conference on Manufacturing Science & Engineering (ICMSE)
  - o Reduces testing cost
- Role of specs and standards
  - o ASTM F-42 on additive manufacturing technologies
  - o When? The standard will take a long time.
  - o Will shops hold their data close?
  - o How will the standards apply to the different systems? Type of laser?
  - o What is the way forward? Seems unknown at this time or a bit fuzzy
  - o More funding will be found because of demand
  - o International competitive issue (from Ian, EWI). What is Germany doing in terms of a standard? They appear to be moving ahead (with the Chinese) while we worry about standards
  - o Applications will drive qualifications and standards
  - o Do we need a “machinists” handbook for additive manufacturing?
  - o Did not discuss materials and particle size; this will be important

#### Brian Rice – UDRI

- Multi-functional thermoplastics for UAV’s
- Large array of nano-polymers
- Large diagnostic capability at UDRI; EMI was one area of research
- Looking for nano-enhanced conductivity.
- DDM Development
  - o Materials development
  - o 3D printer design and setup
  - o Parameters of DDM
  - o Characterization of printed parts
- Fused deposition modeling
  - o Strands of different properties
  - o Carbon fiber TOW filled with PEEK
- SLS – is it more complex than FDM?
- Rapid prototyping to manufacturing
  - o Need material development to advance the technology

- Mechanical properties are different for SLS vs. injection molding; SLS could be better if we understand the process.
- Is it SLS or SLM (melting)? Appears to be more appropriate to use SLM.
- There is a need for quick formulation studies. Currently 2.5 Kg of material are required.
- There was some discussion about carbon nanofiber dispersion improvement
- There was discussion on Integrated Computational Materials and Manufacturing Science and Engineering (ICMSE).

Tim Shinbara – Northrup Grumman, ManTech

- F-35 A, B, C
- Had a good MRL, TRL chart
- Discussed digital part manufacturing for F-35
  - Advanced material process
  - Advanced assembly
  - Using high temperature nylon
  - Fabricating clips, brackets, piping – noncritical parts
- Claimed an ROI of 30:1. Parts are complex and would require 5-axis machining and multiple setups (at least 2 from my notes)
- Mentioned teamwork – Royal, UDRI, Louisville, Paramount.

Bill Macy – Stratasys

- Discussion lights out manufacturing; this goes along with what is discussed at AFRL, etc. They load the machine up and let it run overnight. No personnel required.
- FDM consumes 5X less energy than a CNC process
- Had data from Wichita State
- Data is on the Stratasys website – need to search this out.
- Compared Ultem 9085 vs. Aerospace Aluminum – they compete but may need more material research.
  - Ultem passes burn – FAR 25.853
  - Ultem passes off-gassing – ASTM E595
- The UAV market is very good.

Paramount Industries – Luis Folgar

- Used an insert to deliver a very small amount of material
- Discussed laser sintering anisotropy; can we use this to our advantage?
- Moved from carbon nanotubes to carbon nanofiber; worked with Kenny Johnson, Nanospense, and UDRI
- Killer app may be UAV
- Dispersion is the key
- Discussed beam profile, black body IR source, laser window coating

- Need to handle nanocomposites in a cell with “bunny suits” and respirators. Issues occur when handling powders, cleaning parts, etc.

Tim Gornet – University of Louisville

- ONR funded

Scott Martin – Boeing, St. Louis

- AM is on 10 Boeing platforms
- Design for function
- New academic curriculum
- Machine to machine variation
- Batch and lot traceability and consistency
- ASTM F42 brought up again
- Discussed Direct Manufacturing Research Center.
- Materials and standards appear to be an issue

Art Fritts – Nanospense

- Containment, ventilation, and PPE important
- Working with Paramount; Paramount has invested in a facility in a big way – see their briefing.

George Huang – WSU

- AFRL, Nippon Bunn University; AF gave George a high speed video camera
- Bird muscles are large, insect muscle is small; different flying mechanisms
- Need to reduce current ball bearing size by one-third;
- Interesting gearbox assembly
- Cicada moves wings in a “Figure 8” pattern – ultraslo.com

Panel discussion

- Steve Szaruga
  - o Additive manufacturing can do materials structures that casting cannot do; can also add better monitoring and control
  - o Need to produce quantities and make changes rapidly (<1year) to meet the changing warfighting scenario
  - o New classes of alloys possible
  - o Enabling new material classes
  - o Metals affordability initiative
  - o UAS – Jennifer
  - o SLS – Andrew Nye
  - o E-beam – Frances Abrams
  - o SLS – Jennifer



- Need to find the right applications; not the answer to all
- AM cannot compete with casting except for specialized applications that cannot be done otherwise
- Northrup Grumman – Eric Barnes
  - Current manufacturing methods are holding back advanced concepts
  - UAV applications: HALE, BAT, UCLASS
  - Bracket, clips, ducting are being made by AM processes – these are nonstructural subsystems
  - A question is how to afford qualification
  - Air Force is complex, but has a low volume
  - Predictive model-based process control (can modeling help medical device fabrication?)
  - Definite focus on teaming

## APPENDIX D

### EWI Addition Manufacturing Consortium Meeting

12/6/10

EWI Presentation – Ian Harris

- EWI currently working in additive manufacturing most of this is in arc welding technologies and ultrasonic consolidation.
- GTAW, GMAW, PTA Power can deposit 5-15 lbs of material per hour.
- Difficulty in maintaining fidelity with arc welding processes.
- Deposition Rate vs. Resolution – A good chart for comparing different kinds of additive manufacturing technology. Higher the deposition rate the lower the resolution.

GEAE – Dave Abbott

- Pay off for additive manufacturing is where other technologies can not effectively produce the part or have significant limitations.
- Material Solutions – England (<http://www.materialssolutions.co.uk/>) - One of the best companies for Direct Metal Laser Sintering (DMLS) – service provider.
- Directed MFG (<http://www.directedmfg.com/>) - Top service provider for DMLS and SLS in the US.
- Morris Technologies (<http://www.morristech.com/>) – Top service provider for DMLS in the US
- Electron Beam Sintering – A key technology for metals because it maintains a build temperature above 1300F which eliminates heat treat stress relieving.
- Direct Metal Laser Sintering – Cannot maintain a build temperature above 200F which causes residual stress in the part. This requires support structures to hold geometrical stability and subsequent heat treating to remove the residual stress.
- The part cycle time needs to be reduced by 3-5x to make the technology feasible for mass production of parts.
  - No design allowable database with material properties to guide designers
  - TCT Magazine – Good source of data for additive manufacturing
  - Several Alliances/Consortiums in Europe for Additive Manufacturing
    - DMRC (Direct Manufacturing Research Center - <http://dmrc.uni-paderborn.de/>)
    - Fraunhofer Additive Manufacturing Alliance
    - IMPALA (Intelligent Manufacture from Powder by Advanced Laser Assimilation) – European Funded project.

Connie Philips – NCMS – National Center for Manufacturing Sciences ([www.ncms.org](http://www.ncms.org))

- Additive Manufacturing Initiative with depots
- Working primarily with the Navy
- Doing a lot of reverse engineering
  - Perception, Laser Design, Faro, Hymark
- Have a benchmarking part used – called Amber
- Previous benchmarking part developed by Dick Aubin – Used industry wide
- One released standard ASTM F2792 – Nomenclature for Additive Manufacturing
- NSF completed a roadmap in 2009 for Additive Manufacturing
- Benefits of the Process
  - 50 to 70% reduction in part repair/replacement
  - 78 case studies completed – saved 344 man weeks using additive manufacturing technology
  - 80% of defense dollars go to maintenance
  - 68 additive manufacturing machines across all industry partners
- Reverse engineering/design is a whole in the current value stream
- Challenges/Limitations
  - Cost of materials/machines/maintenance
  - Repeatability across machines – not there
  - Lack of Education – Users
  - Lack of positive experiences
- Need for independent review/testing of equipment and materials
- Funding support for innovation key
  
- SME – Carl Dekker
  - [www.sme.org/ddm](http://www.sme.org/ddm)

## APPENDIX E

### LAM

LAM was initially started by Jim Sears (South Dakota School of Mines), Bill Shiner (IPG), and Paul Denney (Lincoln Electric). LIA support is from Jim Naugle.

170 attendees, 30% growth over last year

Overall impressions of LAM

- Focus was only on metal; only a very brief mention of polymers (TX and EOS)
- Main focus areas are overhaul and repair, direct part fabrication, and cladding
- Most of the work related to very big components, especially cladding

China's work in lasers is expanding very rapidly – Minlin Zhong, Dept. of Mechanical Engineering, Tsinghua University

- 5 National centers
- 45 Universities
- 20 Research institutes
- 130 laser job shops
- 4 “Laser Zones” – almost the entire east coast of China
- 47% of China's research effort is on cladding
- They are doing a lot of work on metal matrix composites (MMC) and SCFE (?)
- China is publishing more on laser cladding than all other countries combined
- China is investigating going to nanoparticles for LAM and discussed wear dependence on particle size (smaller is better)
- They are also doing direct write with 20 micron features and 50 micron spacing for microwave devices.
- Laser companies mentioned were Hans Laser (largest laser company in China), Unity Prima (Shanghi), Dula Laser
- China has a favorable government policy. How does this compare with U.S.?
- It appears that the U.S. is third behind Germany and China; what do we need to do to change this and who will pay for it? Is China catching up to Germany?

Fraunhofer ILT – Ingomar Kelbassa

- Perhaps the best presentation of the conference; got right to the heart of the matter.
- Focus was on blade integrated disc (BLISK); Rolls Royce Deutschland Ltd.
- Discussed the amount of waste from 5-axis milling – question: isn't this material recycled?

- There was a claim that the LMD process uses less energy than the milling process; powder can be recycled so there should be minimal waste. Emphasis on going green. This will be important to AFRL.
- A comparison was done of SLM and LMD processes; briefing was not included, however.
- A 10 KW disk laser (1 micron) was used
- The Fraunhofer cluster was supported by an investment of 10.25M euros – what is the U.S. doing?
- Looking at both micro and macro structure
- The blisk achieved both static and dynamic (high cycle fatigue or HCF) properties; excellent materials characterization
- They are at TRL 7 now and expect TRL 9 by the end of the year
- LMD process reduced time by 30% and material loss by 60%
- Used thru axis camera to monitor the deposition; speed was 4-meters per minute

#### EWI – Ian Harris

- Approached by GE to establish the consortium
- Looking at microstructure models – ThermoCalc, Dictra, JmatPro;
- Working with Applied Optimization (a Dayton company)
- AMC is designed to provide the U.S. an AM forum – Advance manufacturing readiness of metal additive manufacturing technologies to benefit consortium members
- Technical challenges: low cost input materials, cost-effective NDE, real time process control (need to see CLAIM)
- Moving into medical and energy
- AMC Year 1 – SOA review of metal AM processes; ASTM F42
- ODOD – advanced energy projects

#### Fraunhofer IWS (Dresden) – Anja Techel

- Offline programming with DCAM; see <http://www.alotec.de/index.php/en/technology/21-module/16-offline-programmiersystem-dcam>
  - o DCAM 2011 is a standard CAD/CAM software, that was extended with modules for generating robot programs.
  - o Use a E-Maqs CCD camera system and LomPocPro software for controlling the laser
  - o COAX15 cladding head

### TWI Technology Centre – Emma Ashcroft

- Referred to IMPALA project – Intelligent Manufacture from Powder by Advanced Laser Assimilation [http://www.impala-project.eu.com/home/home\\_page\\_static.jsp](http://www.impala-project.eu.com/home/home_page_static.jsp)
  - o Working with multiple partners; one is Cochlear. Using LMD or SLM to fabricate cochlear implants with 10 micron resolution.
  - o Using plasma atomized Ti64 powder
  - o Feature sizes as small as 20 microns
  - o Still need to evaluate quality

### MMT Technologies or now SLM Solutions GmbH – Stefan Ritt

- The SLM 250 HL as an operation window of 250 mm x 250 mm x 250 mm; expandable to 350 mm
- Working in dental, jaw bone, hip joints
- Closed loop powder recycling
  - o Particle size <10 micron can be inhaled into the lungs
    - Would this be something of interest to RH? HPW?
- Working in aeronautic, automotive, engineering, and dental tooling; also discussed conformal cooling
- Dental crowns are a good area – can do 400 units per shift, which is a real time saver; usually only 12 per day are done now.
- Bone replacement for the army – Walter Reed;
- Multi-metal manufacturing approach

### EOS – Bob Evans

- Working in nylons and metals; PEEK
- Dental, orthopedic, medical device
- U.S. can only work in CoCr (FDA approval for this material)
- Customize tools to a surgeons hand
- Implant market was \$26B in 2007
- Lattice structures produced – need to refer to slides;
- Cranial implant from PEEK – TF with WSU as a partner on the research?
- Can do multiple teeth at one time (consistent with MTT)
- Works from stl files.

### Steve Weiss

- Focusing on lean, quality, 6 sigma
- Really dumbed down the operation for operators – primarily because the machines are going off shore to Puerto Rico, Mexico, etc.
  - o Operators can only run specific programs

- No operators can set up machines
- Operator is taken completely out of the equation
- In terms of process control medical is ahead of aviation

#### Sulzer Innotec – Dr. Thomas Peters – Switzerland

- Tip reconstruction
- Weld buildups of 6-13 mm
- 5-axis simultaneous laser welding on a radial turbine
- Reference from website: [http://www.sulzerinnotec.com/en/desktopdefault.aspx/tabid-753/searchcall-75/75\\_keepvisible-true/redirected-1/?/sid-2215410/mid-75/tid-753/ct-0/q-laser//k-/et-0/rpp-0/sar-False/t-/p-0/ap-True/cat-/cr-0/pr-0/icp-False/icc-False/ifc-False/sl-2/sp-0/cs-/](http://www.sulzerinnotec.com/en/desktopdefault.aspx/tabid-753/searchcall-75/75_keepvisible-true/redirected-1/?/sid-2215410/mid-75/tid-753/ct-0/q-laser//k-/et-0/rpp-0/sar-False/t-/p-0/ap-True/cat-/cr-0/pr-0/icp-False/icc-False/ifc-False/sl-2/sp-0/cs-/)
- Better than PTA weld, thermal spray, galvanic process, TIG weld; all these are competing processes
- Additional references and technology discussion: [http://www.sulzerinnotec.com/en/desktopdefault.aspx/tabid-70/4025\\_read-6761/](http://www.sulzerinnotec.com/en/desktopdefault.aspx/tabid-70/4025_read-6761/)
- Putting down Stellites (hard coating)

#### Siemens – Ovidiu Timotin

- Gas Turbine Blade Repair using LMD
- From Hamilton, Ontario
- Using a Fanuc 6 axis robot; all COTS available today
- Using the ILT coax nozzle
- Performing a pulsed LMD process to reduce heat; discussed how this could simulate that TIG process

#### Hard Chrome Engineering – Andrew Dugan

- IPG 4 kW fiber laser – really big stuff
- Cladding with 420 SS

#### GE Global Research – Magdi Azer

- Good presentation
- Mentioned Todd Rockstroh, Dave Abbot
- Took 7 years to get LSP into production
- LA Tech at GE
- Mentioned metals affordability initiative – this was an AF program a few years back
- Gave a good history of the technology – his presentation will be a good one to review
- They over deposit and machine back

- Terry Wohler in 2006 stated that material properties will hold back the process; this is a major point for AFRL and was discussed at length at AMC. At AMC there was a lot of discussion around how much it would cost. So what are the Germans and the Chinese doing? Will we have to purchase our material from them?
- Showed a 42" Ti64 part made in GRC Shanghi – a thin wall, metal leading edge for a composite blade; this is what Dave Abbot had at the AMC meeting. Need the metal edge to combat bird strikes, etc.
- Airbus wants to build an entire engine by additive manufacturing – by when?
- The focus is to reduce “buy to fly” time
- What is the world’s supply of material? More importantly where is it? If it is in China we have a major problem. How can the U.S. continue to access the material?
  - o Powder lets itself to be recycled – a major point for green manufacturing
- Need material properties
  - o Isn’t this what AMC is supposed to do? How will they do it and with what funding?
  - o What about GE?
  - o What about China, Germany?
- Build volumes need to be larger – 6’ by 3’ tall
- Need to chart the MLR’s
- Where are the limitations today?
  - o Can the AF provide this information or do we need to determine it for them?
- Good comment: OEM sells you a system, not a process
- We need to rethink the design process in incorporate additive manufacturing processes; a new manufacturing paradigm – open up the design space
- Commodity processes will be rising
  - o What does this mean for materials
  - o Where is the world’s supply of materials
  - o How will this impact the U.S.?

#### University of Texas – David Bourell

- Good overview of history of the technology
- AM is good for low production runs and complicated geometries; good comparison – 2D printers vs. newspapers
- Sited Wohler’s report of 2010; AM is doubling every 8-9 years
- Patent applications are on the increase
- Aerospace, medical and dental = 25%; what is the rest?
- U.S. is losing market share? Not surprising, but to whom?
- Lot of interesting history on the patent literature, but a bit tedious; clearly a lot of work went into this



- Roadmap for Additive Manufacturing – [wohlerassociates.com/roadmap2009.html](http://wohlerassociates.com/roadmap2009.html); 92 page report on research needs; hard copy received from David

Alabama Laser – Wayne Penn; Juan Nava (Alstom Power) also spoke in this presentation

- Preheat wire used as feed stock by applying current
- Hot wire melt pool is very stable
- Dr. Juan Nava – boiler cladding; 8,000 square feet to cover
  - o Thickness and chemistry must be maintained
  - o Cr rules in the boiler industry for corrosion properties
  - o Faster deposition rate than TIG, MIG
  - o Thinner cladding
  - o Details on company at [www.power.alstom.com](http://www.power.alstom.com)

Supersonic Laser Deposition Technology – Bill O’Neill

- Working with Ti, SS316, IN718, Cu
- Working with IPG (Bill Shiner)
- Good coatings, ~CS (?) but much lower cost
- If powder bounces off it remains spherical and can be recycled
  - o Lot of emphasis on recycling
- Bill gives a good presentation; puts more science into it than most

Carpenter Powder Products – John Hunter

- Powder specifications for LAM process will be important
- Discussed different ways of making particle size
  - o Plasma atomization
  - o Water atomization
  - o Gas atomization
- Critical powder parameters
  - o Chemistry – specs, accuracy, consistency
  - o Size distribution
  - o Yields
  - o Material properties will be important
  - o QC is important and should be of interest to the AF
  - o Didn’t appear to know much about his process

#### The POM Group, Inc. – Bhaskar Dutta

- Work is with Joyti M. (CLAIM)
- Joyti is CEO of the POM Group – a spin off from U Mich.
- Focus is on monitoring and control
- Showed tissue engineering scaffolds
- Manufacture Direct Metal Deposition (DMD) machines and showed several
- Have closed loop process control
- There is a major emphasis on modeling
- They have developed a micro structure sensor; used on a Ti-Fe alloy
  - o Patent pending
  - o Didn't say how it worked
  - o Measuring atomic percent
  - o We need to study this briefing
- Results
  - o Geometry control
  - o Melt pool T control
  - o Composition sensor
  - o Micro-structure monitoring
- All work was done at CLAIM

#### Hoganas – Ingrid Hauer

- New SS powders for laser cladding
- SS used to stop pitting and corrosion from Cl ion; a passivation issue?
- SS comparable to Stellite 6
- Also working with Stellite 12 for wear resistanc

#### Laser Cladding for Renewal of Rotating Equipment – Jelmer Brugman

- Addressing the problem of rotating bending fatigue
- Spoke about the Wohler curve
- Cladding works and is cost effective; showed application of wind turbine gear boxes

#### Alex Groth – Fraunhofer grad

- Worked in Plymouth, MI
- Focus was laser cladding with higher deposition rates

#### Eckhard Beyer – Fraunhofer IWS

- Discussed surface cladding, repair, and direct manufacturing
- TC/W cladding – 18 kg/hr

- Inconel 625 – 6.3 kg/hr
- COAX powerline nozzle – new design with a 25 mm opening; requires a 10 kW laser
- Uses inductive heating to heat substrate while laying down cladding
  - o Inconel deposited with a 8 kW laser, 12 kW induction
- Diode lasers preferable
- Induction heating
  - o 18-25 kW power for preheating
  - o Frequency 10 kHz
  - o Distance from surface ~1 mm
  - o Claimed diode laser was 30% efficient – an area we can look into that will be of interest to AF
  - o Prevents micro-cracking in hard cladding; mentioned Stellite 20 – 56-62 HRC
- Showed a propeller shaft that was 11 meters long and weighted 26 tons
  - o Coated in 100 hours
  - o 6 kW diode, IWS COAX 8 nozzle
  - o 8 person team
- Contact person is Craig Bratt – CCL
  - o [cbratt@fraunhofer.org](mailto:cbratt@fraunhofer.org)
  - o [www.ccl.fraunhofer.org](http://www.ccl.fraunhofer.org)

#### Caterpillar – Kristin Schipull

- Caterpillar used 115,000 lb of SS powder in 2010
- Coating shafts from earth movers, etc.
  - o 5 ft diameter by 7 ft long; 8,000 lb
- Commented that WC is expensive

#### Naval Undersea Warfare Center – Lee Nathan

- Al 4047 repair on torpedo case
- Showed a CH-53E Seal Stallion Automated Rotor Blade Stripping System (ARBSS) – not exactly AM
- Corrosion and wear – what about aircraft on carriers or aircraft in general; is AFRL doing any of this research?
- Doing Repair, Restoration, Reconfiguration, and Reconstruction (R4) with POM;
- Mobile DMD in a shipping container
  - o A mobile part hospital
  - o Ship to forward bases in Iraq, Afghanistan, etc.
- Showed Virginia Class submarine – our fastest attack submarine
  - o Shaft repair – pull shaft or do in situ

Thermal imaging for LAM – Joshua Hammell

- Process diagnostics
- FAR Associates Spectro Pyrometer
- Mikron cameras – M9200 and M7500

**APPENDIX F**  
**RXMT/Industrial Base Information Center (IBIC) Report**

*IBIC appreciates any comments or suggestions regarding our products*

**IBIC Project 10-024**

**DATE: 18 Feb 11**

**PROJECT SUMMARY MEMORANDUM**

<b>SUBJECT(s):</b>	<b>IBIC SUPPORT OF THE DIRECT DIGITAL MANUFACTURING TASK</b>
<b>REQUEST DATE:</b>	<b>09 Dec 10</b>
<b>CUSTOMER(s):</b>	<b>AFRL/RXMT</b>
<b>IBIC OPR:</b>	<b>Various</b>

**INFORMATION REQUESTED:**

The customer requested information to support the Direct Digital Manufacturing (DDM) task. Specific information includes the following areas of digital manufacturing: additive/subtractive manufacturing, reverse engineering, and CAD/CAM technologies. Each area is to include a brief description of the pros and cons and, if available, associated equipment costs.

**FINDINGS/COMMENTS:**

Comments:

Associated equipment cost information was not readily available and is therefore not addressed in this report.

Findings:

This report identifies digital manufacturing equipment manufacturers. Table 1 identifies the additive manufacturing equipment manufacturers. There are 19 total, 10 are US and 9 are foreign. Table 2 identifies the subtractive manufacturing equipment manufacturers. There are 22 total, 13 are US and 9 are foreign. Additionally, Amada Machine Tools America and Mazak Corporation are owned by Japanese companies but operate US facilities so the companies are considered domestic for this report.

**Table 1. Additive Manufacturing Equipment Manufacturers**

Companies	Location	SLA	SLS	DMLS	EBM	DMD	FDM	IJP
3D Systems	Rock Hill	X	X					X
EX One	Irvin, PA							X
Huffman Technologies	Clover, SC					X		
Objet Geometries	Billerica, MA							X
Optomec	Albuquerque, NM					X		
POM	Auburn Hills, MI					X		
Solidica (Additive/Hybrid)	Ann Arbor, MI							
Solidscap	Merrimack, NH							X
Stratasys	Eden Prairie, MN						X	
Z Corp	Burlington, MA							X

SLA – Stereolithography, SLS – Selective laser sintering, DMLS – Direct metal laser sintering, EBM – Electron beam melting, DMD – Direct metal deposition, FDM – Fused deposition modeling, IJP – Ink jet printing/3D Printing

\*IBIC is Operated for the Integration & Technology Branch (AFRL/RXMT) by Azimuth Corporation

**Table 1. Additive Manufacturing Equipment Manufacturers (Continued)**

Companies	Location	SLA	SLS	DMLS	EBM	DMD	FDM	IJP
<a href="#">ARCAM</a>	Sweden				X			
<a href="#">Bits from Bytes</a>	UK							X
<a href="#">Concept Laser</a>	Germany			X				
<a href="#">Digital Wax Systems</a>	Italy	X						
<a href="#">Envisiontec</a>	Germany							X
<a href="#">EOS</a>	Germany			X				
<a href="#">MTT Technologies</a>	UK			X				
<a href="#">Phenix Svstems</a>	France		X					
<a href="#">Voxeljet</a>	Germany							X

SLA – Stereolithography, SLS – Selective laser sintering, DMLS – Direct metal laser sintering, EBM – Electron beam melting, DMD – Direct metal deposition, FDM – Fused deposition modeling, IJP – Ink jet printing/3D Printing

**Table 2. Subtractive Manufacturing Equipment Manufacturers**

Companies	Location	CNC	CNC mM	AWJ	AmWJ	mEDM	LMM
<a href="#">Amada Machine Tools America</a>	Schaumburg, IL	X					
<a href="#">CNC Masters</a>	Irwindale, CA	X					
<a href="#">EX One</a>	Irvin, PA						X
<a href="#">Flow International</a>	Kent, WA			X			
<a href="#">Haas Automation Inc</a>	Oxnard, CA	X					
<a href="#">JPSA</a>	Manchester, NH						X
<a href="#">Mazak Corporation (Parent Yamazaki Mazak-Japan)</a>	Florence, KY	X					
<a href="#">Microlution</a>	Chicago, IL		X				
<a href="#">OMAX</a>	Kent, WA			X			
<a href="#">Oxford Lasers</a>	Shirley, MA						X
<a href="#">Resonetics</a>	Nashua, NH						X
<a href="#">SmalTec International</a>	Lisle, IL					X	
<a href="#">WARDJet</a>	Tallmadge, OH			X			
<a href="#">3D MicroMac</a>	Germany						X
<a href="#">BARON-MAX</a>	Taiwan	X					
<a href="#">Doosan</a>	China	X					
<a href="#">Matsuura</a>	Japan	X					
<a href="#">Makino</a>	Japan	X				X	
<a href="#">Micro Waterjet LLC</a>	Switzerland				X		
<a href="#">Mori Seiki</a>	Japan	X					
<a href="#">Posalux</a>	Switzerland	X				X	X
<a href="#">Sarix</a>	Switzerland					X	

CNC – Computer numeric control, CNC mM – CNC micro machining, AWJ – Abrasive water jet, AmWJ – Abrasive micro water jet, mEDM – Micro electrical discharge machining, LMM – Laser micromachining

Financially, the US sector is healthy. Of the 22 companies\*, seven were not rated due to insufficient data. Of the remaining 15 companies, nine were rated low risk, six were given a moderate rating and none were rated high risk. None of the foreign companies were rated for financial risk.

\* - The EX One company manufactures both additive and subtractive manufacturing equipment and is listed in both sections, but it is counted as 1 in the total company count.

\*IBIC is Operated for the Integration & Technology Branch (AFRL/RXMT) by Azimuth Corporation

## Table of Contents

<b>INTRODUCTION</b>	<b>1</b>
<b>ADDITIVE MANUFACTURING</b>	<b>1</b>
Advantages/Disadvantages .....	1
Table 3. Description of Additive Technologies .....	3
Stereolithography (SLA).....	3
Selective Laser Sintering (SLS).....	3
Direct Metal Laser Sintering (DMLS) .....	4
Electron Beam Melting (EBM).....	5
Direct Metal Deposition (DMD) .....	5
Fused Deposition Modeling (FDM) .....	6
Ink Jet Printing .....	7
<b>SUBTRACTIVE MANUFACTURING</b>	<b>8</b>
Table 4. Description of Subtractive Technologies.....	8
CNC.....	8
CNC Micro Machining .....	8
Abrasive Water Jet (AWJ).....	9
Abrasive MicroWater Jet (AmWJ).....	9
Micro Electrical Discharge Machining (mEDM).....	10
LASER Micromachining (LMM).....	10
<b>REVERSE ENGINEERING</b>	<b>11</b>
<b>CAD/CAM TECHNOLOGIES</b>	<b>11</b>
<b>SKILL SETS REQUIRED</b>	<b>11</b>
<b>MARKET INFORMATION</b>	<b>12</b>
<b>DIGITAL MANUFACTURERS - EQUIPMENT</b>	<b>12</b>
Table 5. Domestic Digital Manufacturing Companies.....	12
Table 6. Foreign Digital Manufacturing Companies.....	16
<b>DIGITAL EQUIPMENT MANUFACTURERS FINANCIAL INFORMATION</b>	<b>19</b>
Table 7. Critria Used To Determine Financial Ratings .....	19
<b>SOURCES</b>	<b>19</b>

---

\*IBIC is Operated for the Integration & Technology Branch (AFRL/RXMT) by Azimuth Corporation



## INTRODUCTION

Direct Digital Manufacturing (DDM) is a process that saves time and money in the development of new products and is used extensively in the automotive and aerospace industries. Digital manufacturing incorporates the whole process of how to build the next product and is more than identifying which machine tools to use. Things to consider include what plants to build it in, how to accommodate the different variants of products, and how to make sure the product is built quicker, faster, and cheaper, with better quality than a competitor.

DDM equipment can be categorized into the following three areas: additive manufacturing, subtractive manufacturing and hybrid manufacturing. Additive manufacturing is a process in which a product is manufactured by adding one layer at a time. Conventional subtractive manufacturing is a process in which a product is manufactured by reducing a solid block of metal or other material by any combination of drilling, cutting and grinding.

Although this report is not a technical document there are several areas which require some explanation.

1. Direct digital manufacturing is a manufacturing process which creates physical parts directly from 3D CAD files. It is sometimes called rapid, instant, or on-demand manufacturing.
2. Reverse engineering is a method for creating a 3D virtual model of an existing physical part for use in 3D CAD, CAM, CAE and other software.
3. Computer Aided Design (CAD) technology is using computer systems to assist in the creation, modification, analysis, and optimization of a design.
4. Computer Aided Manufacturing (CAM) technology involves computer systems that plan, manage, and control the manufacturing operations through computer interface with the plant's production resources.
5. A stereolithography file (.STL file) is used to generate information needed to produce 3D models. It is a triangular representation of the 3D object with the surface broken into logical series of triangles. Each triangle is defined by its normal and three points representing its vertices. A good .STL file will have enough triangles the curved area as smooth (not hexagonal) and not too many that the file becomes unmanageable.

## ADDITIVE MANUFACTURING

### Advantages/Disadvantages

There are many positive and exciting examples where production of finished goods are meeting customer needs and replacing historical methods of production. The choice of which parts can and should be made utilizing additive manufacturing is endless. Many parts that were once identified as being complex suddenly fit well into the additive manufacturing process. For companies/service providers who deal with the aerospace and medical industries, the question is not can parts be made using additive technologies, but rather can parts be made to production and quality expectations. One industry projection for the future would involve the use of a single machine for the design, prototype, and finished part.

### Advantages

Rapid Deployment Time – Once the CAD design is complete, it can be converted to an STL file and the production process can begin. Conventional methods would require the design to be completed and additional time required for the "tooling" phase. Production could not be started until both processes were completed. Result is a short cycle-time for delivery of manufactured items utilizing DDM. Computerized numeric control (CNC) deliveries typically take seven to 12 working days. This delivery varies based on available materials, complex geometries, number of setups and current workload. With the additional time needed for programming, setup and fixtures it is difficult to consistently keep faster leadtimes.

Low Capital Expenditure – Traditional manufacturing methods require tools and dies that are expensive to produce. DDM requires no tooling therefore the initial cash outlay to start manufacturing is reduced.

Unlimited Complexity – DDM constructs parts using one of the many additive technologies, the design complexity is unlimited. This promotes product innovation and allows the designers to optimize performance of the part. Additionally, there are no additional costs or time requirements to manufacture complex designs as compared to simple products. Custom systems utilizing additive manufacturing techniques permit accurate repeatability of each process for recurring production runs.

Freedom to Redesign – Equally as important is the ability to re-design at any point in the production lifecycle. Since tooling has been eliminated, there is no penalty for production redesigns. A component may be revised without adding manufacturing expense or production delay. With traditional manufacturing methods, there is a point in the product development cycle where the design is "frozen". From that moment on, design revisions are unacceptable and are accommodated at great expense. With DDM, the design is never frozen. It is perpetually fluid and adaptable to the needs of the product, company and consumer.

Output Qualities – Over the past few years, there have been technological advances that have improved the quality of parts produced through DDM. It is expected that these advancements will continue and that part quality will be further improved.

Low Material Waste - Since the process only forms the desired part, there is almost no waste formed, again in contrast to conventional machining. The absence of waste enhances energy efficiency, as energy is not used to transport or dispose of waste.

**Disadvantages:**

Low Quantities - DDM is not a high volume manufacturing process. If demands are for millions of units a year, DDM will not be the right solution. Typically, DDM is used when production quantities range from one to 10,000 units per year. The justifiable production quantity will vary with the size of the component. As part size decreases, the annual production quantity increases.

**Processes/Technologies**

3D printers, which emerged more than a decade ago, are the fastest-growing sector of additive fabrication. 3D printing evolved from the "rapid prototyping" industry. 3D printing builds plastic and metal parts directly from CAD drawings that have been cross sectioned into thousands of layers. It provides a faster and less costly alternative to machining (cutting, turning, grinding and drilling solid materials).

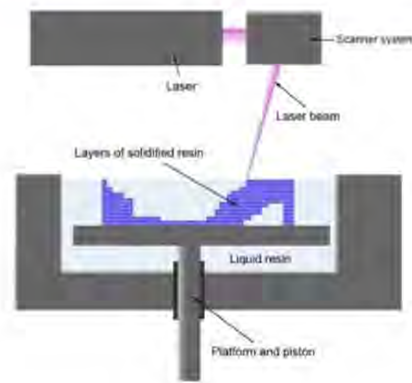
3D printing can be used for prototyping as well as final production. When a small low cost device is used it is called desktop or personal manufacturing. The primary distinction between the uses of terms to describe 3D printing is that additive freeform fabrication is solely intended to describe a 3D printed part that is to be used as the final product with minimal post-processing. Whereas other terms used to describe rapid prototyping, additive freeform fabrication and the like are simply alternative ways of describing the 3D printing process itself.

There are several 3D printing technologies within additive manufacturing. The oldest technology is layered object manufacturing. The next oldest is stereolithography (SLA). Since the early days of SLA, more recent technologies include selective laser sintering (SLS), electron beam melting (EBM), direct metal deposition (DMD), fused deposition modeling (FDM), and other variations. All of these technologies take a 3D model; compute cross sections of that model, then deposit the cross sections sequentially on top of each other until the final geometry is reached. Varying the layer thickness affects the model finish. Each technology is described in Table 3.

**Table 3. Description of Additive Technologies**

**Stereolithography (SLA)**

SLA is one of the older, more established additive manufacturing technologies but it is still widely utilized in the direct manufacturing market. It also starts with the 3D CAD image (STL file) and uses a laser to form the product. However, SLA utilizes a liquid polymer in contrast to the powdered material that SLS, DMLS and DMD use. It uses a vat of liquid UV-curable photopolymer "resin" and a UV laser to build parts a layer at a time. On each layer, the laser beam traces a part cross-section pattern on the surface of the liquid resin. Exposure to the UV laser light cures solidifies the pattern traced on the resin and adheres it to the layer below. Then, a resin-filled blade sweeps across the part cross section, re-coating it with fresh material.



On this new liquid surface, the subsequent layer pattern is traced, adhering to the previous layer. A complete 3D part is formed by this process. After building, parts are cleaned of excess resin by immersion in a chemical bath and then cured in a UV oven. SLA requires the use of support structures that attach the part to the elevator platform. This prevents certain geometries from not only deflecting due to gravity, but to also accurately hold the 2D cross sections in place such that they resist lateral pressure from the re-coater blade. Supports are generated automatically during the preparation of 3D CAD models for use on the stereolithography machine, although they may be manipulated, supports must be removed from the finished product manually.

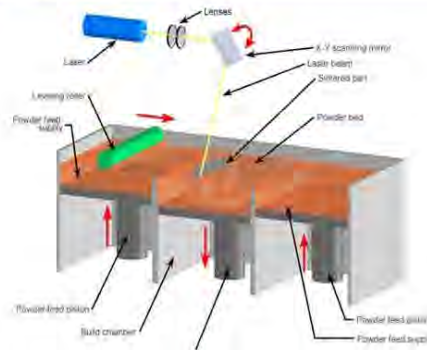
The following link provides a video from 3D Systems on how the Stereolithography technology works. [SLA - Video](#)

**Companies Utilizing SLA:**

- 3D Systems – Domestic
- Digital Wax Systems – Foreign

**Selective Laser Sintering (SLS)**

SLS was developed at the University of Texas in the 1980s under the sponsorship of DARPA. It is an additive manufacturing technique that uses a high-power laser to fuse small particles of plastic, metal (steel, titanium, alloys and composites), ceramic or glass powders to form the 3-dimensional product. The laser selectively fuses the powdered material by scanning cross-sections generated from a 3D digital description of the part, generally from a CAD file, on the surface of a powder bed. After each cross-section is scanned, the powder bed is lowered by one layer thickness, a new layer of material is applied on top, and the process is repeated until the part is completed.



**Table 3. Description of Additive Technologies (Continued)**

**Selective Laser Sintering (SLS)**

Most SLS machines utilize two-component powder that is heated to just below its melting. They typically use a pulsed laser to bring the powder up to its melting point, forming each layer of the product. Unlike other techniques, SLS does not require support structures due to the fact that the part being constructed is surrounded by unsintered powder at all times. FDM and SLS are the two main contenders for nonmetallic materials.

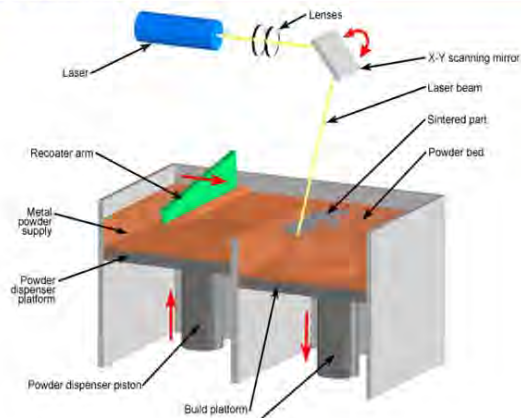
The following link provides a video from 3D Systems on how the SLS process works. [SLS - Video](#)

**Companies Utilizing SLS:**

3D Systems – Domestic  
Phenix Systems – Foreign

**Direct Metal Laser Sintering (DMLS)**

Direct Metal Laser Sintering (DMLS) was developed by Rapid Product Innovations and EOS GmbH in 1994. This technology uses the same basic process as SLS. However, DMLS utilizes very small diameter metal powder which is free of a binder or fluxing agent. It is completely melted by the laser and produces a 95% dense steel part compared to the 70% density from SLS systems. Also, the use of smaller diameter powder results in products with a higher detail resolution due to the use of thinner layers. This capability allows for more intricate, detailed part shapes. These systems can use alloy steel, stainless steel, tool steel, aluminum, bronze, cobalt-chrome, and titanium metal powders.



The following link provides a video from EOS on how the DMLS technology works. [DMLS - Video](#)

**Companies Utilizing DMLS:**

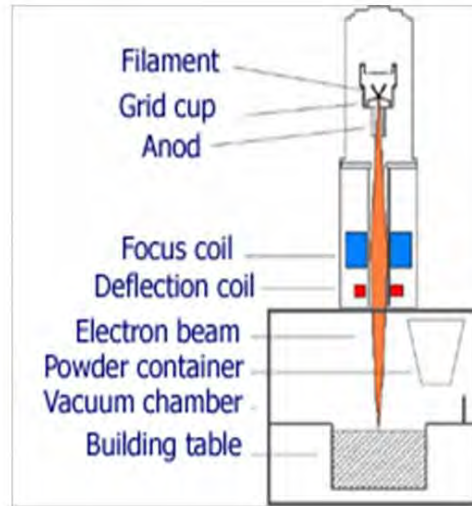
EOS – Foreign  
MTT – Foreign  
Concept Laser – Foreign

**Table 3. Description of Additive Technologies (Continued)**

**Electron Beam Melting (EBM)**

This additive manufacturing technology was developed in Sweden and utilizes an electron beam instead of a laser to produce a 100% solid metallic object made directly from metal powder. From a magazine of powder, an equally thin layer of powder is scraped onto a vertically adjustable surface. The first layer's geometry is then created through the layer of powder melting together at those points directed from the CAD file, with a computer controlled electron beam. Thereafter, the building surface is lowered just as much as the layer of powder is thick, and the next layer of powder is placed on top of the previous. The procedure is then repeated so that the object from the CAD model is shaped, layer by layer by layer, until a finished metal part is complete.

The usage of a highly efficient computer controlled electron beam in vacuum provides high precision and quality.



The following link provides a video from Arcam on how the Electron Beam Melting technology works.  
[EBM Video](#)

**Companies Utilizing EBM:**

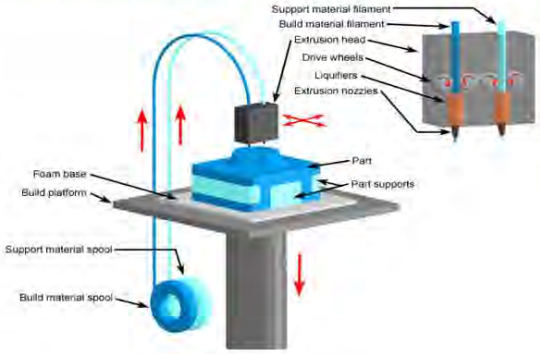
Arcam – Foreign

**Direct Metal Deposition (DMD)**

This additive manufacturing technology uses powdered material and a laser; however it differs from DMLS and SLS in the application of the powdered material. In DMLS and SLS, a thin layer of powder is spread out and heated and re-accomplished until the product is complete. In DMD, a laser beam is focused onto a flat tool-steel workpiece or preformed shape to create a molten pool of metal. A small stream of powdered material is then injected into the melt pool to increase the size of the molten pool. The molten pool cools and solidifies rapidly producing the metal form. The laser beam moves back and forth with the solid metal product being built one layer at a time.



**Table 3. Description of Additive Technologies (Continued)**

Direct Metal Deposition (DMD)	
The following link provides a video from Trumpf on how the DMD technology works. <a href="#">DMD Video</a>	
<b><u>Companies Utilizing DMD</u></b> Optomec – Domestic Huffman Technologies – Domestic POM – Domestic	
Fused Deposition Modeling (FDM)	
<p>FDM is an established additive manufacturing technology developed by Stratasys. This system uses a specially design nozzle and a thermoplastic material to build the parts. A CAM software package controls the movement, both horizontal and vertical directions, of the nozzle. The nozzle is heated and extrudes small beads of thermoplastic material to form layers of the part. This material hardens immediately after it is extruded from the nozzle. Like SLA, FDM must also make temporary structures to provide support as this system does not use any powdered materials while the manufacturing is in progress.</p> <p>A "water-soluble" material can be used for making temporary supports while manufacturing is in progress, this soluble support material is quickly dissolved with specialized mechanical agitation equipment utilizing a precisely heated sodium hydroxide solution.</p> <p>FDM utilizes several different materials; each with different trade-offs between strength and temperature properties. Possible materials include acrylonitrile butadiene styrene (ABS) polymer, polycarbonates, polycaprolactone, polyphenylsulfones and waxes. FDM and SLS are the two main contenders for nonmetallic materials.</p>	
<b><u>Companies Utilizing FDM:</u></b> Stratasys – Domestic Bits From Bytes – Foreign	

**Table 3. Description of Additive Technologies (Continued)**

**Ink Jet Printing**

This additive manufacturing technology uses inkjet printing heads instead of lasers or electron beams to form the cross-sections of the parts. There are a variety of techniques that utilize this technology.

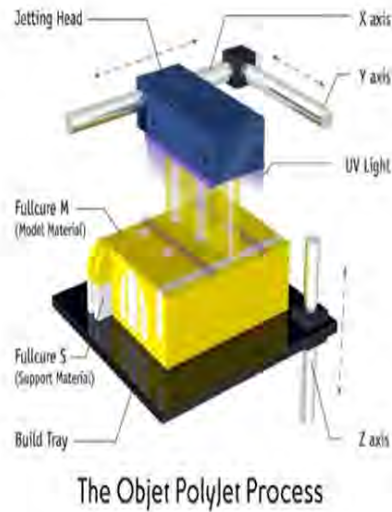
One version of inkjet technology works by jetting state of the art photopolymer materials in ultra-thin layers onto a build tray layer by layer until the part is completed. Each photopolymer layer is cured by UV light immediately after it is jetted, producing fully cured models that can be handled and used immediately, without post-curing.

As shown opposite, Objet's PolyJet Matrix technology works by jetting two distinct Objet FullCure® photopolymer model materials in preset combinations.

Since there is no powdered material, support structures need to be formed. Gel-like support material, which is specially designed to support complicated geometries, is utilized. After the process is completed, the support is easily removed by hand and water jetting.

A second version of inkjet technology starts off with a thin layer of powdered material on a platform. It can be either a metal or plastic-type material. The inkjet nozzle dispenses a binder material, which can be applied in a variety of colors, to form the cross-section of the part. The platform is then lowered one layer and a thin layer of powdered material is re-applied. This process is continued until the part is completed. Support structures are not required to be formed since the "unbounded" powdered material provides this function.

The final step in the process depends on what type of powdered material was utilized. Plastic-type powdered material can just be removed, leaving the finished part. Metal-type parts need to be thermally processed in order to complete the product.



**Companies Utilizing Ink Jet Printing**

- 3D Systems - Domestic
- EXone - Domestic
- Objet - Domestic
- SolidScape - Domestic
- Z Corp - Domestic
- Envisiontec - Foreign
- Voxeljet - Foreign

## SUBTRACTIVE MANUFACTURING

### Processes/Technologies

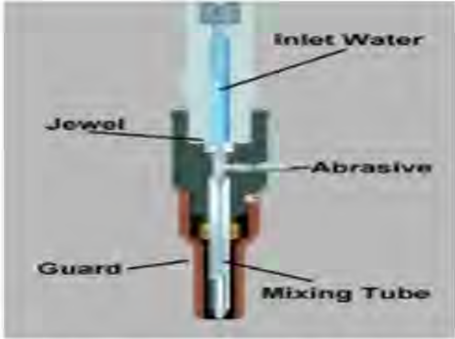
There are several processes within subtractive manufacturing. The oldest technology is CNC machining. Since the days of CNC, more recent technologies include abrasive water jet (AWJ), abrasive micro water jet (AmWJ), micro electrical discharge machining (mEDM), and laser micro machining (LMM). Each technology is described in Table 4.

**Table 4. Description of Subtractive Technologies**

CNC	
<p>Both numeric controlled (NC) and computerized NC machines are used to describe this category of automated machine tools, such as drills and lathes that operate from instructions in a program.</p> <p>NC machines are used in manufacturing tasks, such as milling, turning, punching and drilling. First-generation machines were hardwired to perform specific tasks or programmed in a very low-level machine language. Today, they are controlled by microprocessors and are programmed in high-level languages, which automatically generate the physical motions required to perform the operation, commonly called the tool path.</p> <p><b><u>Companies Utilizing CNC</u></b>                      Haas - Domestic                      Morei Seiki - Domestic                      CNC Masters - Domestic                      Amada Machine Tools - Domestic                      Mazak Corp - Domestic                      Baron Max - Foreign                      Doosan - Foreign                      Matsura - Foreign                      Makino - Foreign                      Morei Seiki - Foreign                      Posalux - Foreign</p>	 <p>CNC MASTERS' Table Top Mill</p>
CNC Micro Machining	
<p>Similar to conventional CNC machining but with finer tools, more precise positioning, and visual systems for microscopic inspection.</p>	<p><b><u>Companies Utilizing CNC Micro Machining</u></b>                      SmalTec - Domestic                      Microlution - Domestic                      Makino - Foreign</p>



**Table 4. Description of Subtractive Technologies (Continued)**

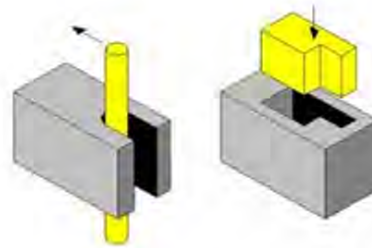
Abrasive Water Jet (AWJ)	
<b>Abrasive Water Jet (AWJ) and Pure Water Jet (WJ)</b>	
<p>The use of ultra-high water pressure (&gt;30,000 psi) has been studied since 1950. Water jet technology has improved and is now capable of cutting a variety of products ranging from the soft cloth to the hardest metals and composites. Diamonds and tempered glass are some of the few products you cannot use water jet technology on. The soft materials can be cut with pure water jet only while the harder material need an abrasive material added to the water. Garnet is normally the abrasive material of choice; however aluminum oxide and silicon carbide can us used. The inlet water for a pure water jet is pressurized between 20,000 and 60,000 PSI. This is forced through a tiny hole in the jewel, which is typically 0.007" to 0.020" in diameter (0.18 to 0.4 mm). This creates a very high-velocity, very thin beam of water traveling close to the speed of sound (about 600 mph or 960 km/hr).</p> <p>An abrasive water jet starts out the same as a pure water jet. As the thin stream of water leaves the jewel, however, abrasive is added to the stream and mixed. The high-velocity water exiting the jewel creates a vacuum which pulls abrasive from the abrasive line, which then mixes with the water in the mixing tube. The beam of water accelerates abrasive particles to speeds fast enough to cut through much harder materials.</p> <p><b><u>Companies Utilizing Abrasive Water Jet:</u></b>            Flow – Domestic            OMAX – Domestic            WARDjet – Domestic</p>	
Abrasive MicroWater Jet (AmWJ)	
<p>Micro water jet systems utilize the same technology but with smaller jet diameter and improved precision over conventional water jet systems.</p>	<p><b><u>Companies Utilizing Abrasive Micro Water Jet</u></b>            Micro Water Jet / Daetwyler – Foreign</p>

**Table 4. Description of Subtractive Technologies (Continued)**

**Micro Electrical Discharge Machining (mEDM)**

EDM is a machining method primarily used for electrically conductive, hard metals (hastalloy, hardened tool-steel, titanium, carbide, inconel and kovar) or those that would be very difficult to machine with traditional techniques. It is often included in the 'non-traditional' or 'non-conventional' group of machining methods together with water jet cutting (WJ, AWJ) and laser cutting and opposite to the 'conventional' group (turning, milling, grinding, drilling and any other process whose material removal mechanism is essentially based on mechanical forces).

There are two primary EDM methods: ram EDM and wire EDM. The primary difference between the two involves the electrode that is used to perform the machining. In a typical ram EDM application, a graphite electrode is machined with traditional tools. The specially-shaped electrode is connected to the power source, attached to a ram, and slowly fed into the work piece. The entire machining operation is usually performed while submerged in a fluid bath. In wire EDM, a very thin wire serves as the electrode. Special brass is slowly fed through the material and the electrical discharges actually cut the work piece. These machines may use a stream of dielectric fluid directed at the work piece or they may submerge the work piece completely under the dielectric fluid.



Wire and Ram type EDM

**Companies Utilizing EDM:**

- SmalTec – Domestic
- Sarix – Foreign
- Makino – Foreign
- Posalux – Foreign

Difficulties have been encountered in the definition of the technological parameters that drive the micro process.

**Laser Micromachining (LMM)**

Laser micromachining is the process of manufacturing parts of dimensions from 0.0001 mm to 1.0 mm using the laser beam as a cutting tool. It is used for such functions as micro drilling, signing, cutting, 2D and 3D structuring and marking of various materials and thin films. There are a variety of laser types used in the micromachining process to include excimer and Diode Pumped Solid State lasers.

Micromachining with laser involves the removal of small amounts of material. One side effect of such removal is the peripheral thermal damage to surrounding material usually called the heat-affected zone. Depending on material and application the heat-affected zone can take a form of discoloration, melting material, distortion, microcracking and various other undesirable effects.



Resonetics Rapid X™ 250

**Table 4. Description of Subtractive Technologies (Continued)**

<b>LASER Micromachining (LMM)</b>
Therefore, minimizing the peripheral heating is essential. In some materials, this can be done by using shorter wave length of ultra-violet lasers. In all materials thermal loading can be reduced by using a pulse laser. By pulsing an output of a laser, a high peak power can be achieved with only modest average power. This allows most materials to be micromachined with only a few watts of overall power.
<b><u>Companies Utilizing LMM</u></b> EX One – Domestic JPSA – Domestic Oxford Lasers - Domestic Resonetics- Domestic 3D MicroMac – Foreign Posalux – Foreign

### **REVERSE ENGINEERING**

Reverse engineering is a method for creating a 3D virtual model of an existing physical part for use in 3D CAD, CAM, CAE and other software. Reverse engineering has its origins in the analysis of hardware for commercial or military advantage. The purpose is to deduce design decisions from end products with little or no additional knowledge about the procedures involved in the original production.

There are two parts to any reverse engineering application: scanning and data manipulation. First a physical object is measured. Then it is reconstructed as a 3D model. It often involves taking something apart, analyzing its workings in detail to be used in maintenance, or to try to make a new device that does the same thing without understanding any part of the original.

Scanning, also called digitizing, is the process of gathering the requisite data from an object. What eventually comes out of each of these data collection devices, however, is a description of the physical object in three-dimensional space called a point cloud.

### **CAD/CAM TECHNOLOGIES**

CAD technology is concerned with using computer systems to assist in the creation, modification, analysis, and optimization of a design. The most basic role of CAD is to define the geometry of design: a mechanical part, a product assembly, an architectural structure, an electronic circuit, a building layout, etc.

CAM technology involves computer systems that plan, manage, and control the manufacturing operations through computer interface with the plant's production resources. One of the most important areas of CAM is numerical control. This is the technique of using programmed instructions to control a machine tool, which cuts, mills, grinds, punches or turns raw stock into a finished part. Another significant CAM function is in the programming of robots.

### **SKILL SETS REQUIRED**

Most manufacturing companies have identified serious gaps in the skill sets and knowledge of their workforce, especially among young men and women just entering the workplace with degrees fresh in hand. The largest corporations are able to work directly with educational institutions to get their needs met by developing new programs or enhancing existing curricula, but these results are limited in scope and influence. With colleges and universities to develop potential programs and curricula to fill those gaps, then provide support for those programs. It is this kind of partnership model that will produce large numbers of professionals ready to meet the challenges of today's manufacturing environment.

## MARKET INFORMATION

Wohlers Associates, Inc. is a 24-year-old independent consulting firm that works closely with manufacturing organizations to identify the best approaches to rapid product development and additive manufacturing. The company has provided consulting assistance to more than 160 organizations in 21 countries.

According to Wohler's 2010 Report, demand for products and services from additive manufacturing technology has been strong over its 22-year history. The compound annual growth rate (CAGR) of revenues produced by all products and services over this period is 26.4%. The CAGR slowed to 3.3% over the past three years, with 2009 being the slowest in many years, by far. Despite a weak 2009 overall, unit sales were strong due to the impact of low-cost machines based on open-source developments. Annual unit sales of AM systems worldwide grew by an estimated 13.9%.

## DIGITAL MANUFACTURERS - EQUIPMENT

Manufacturing equipment capabilities vary based on supplier, type of machine (plastics or metals) and actual materials used. Speed and productivity continue to improve at an accelerated pace. Most platforms are small in scale today but as industry demand grows, technical improvements will be made to enable higher and higher volumes of production parts. Companies use both additive and subtractive manufacturing techniques to produce the parts. Table 5 lists the domestic companies that produce the equipment utilized in the "additive and subtractive" manufacturing market.

### Domestic Companies

Research identified 22 domestic companies that produce digital manufacturing equipment. Table 5 is split between companies that manufacture equipment utilizing additive manufacturing processes (10 companies) and those utilizing subtractive manufacturing processes (13 companies). The table contains hyperlinks to each company's website, the technology they specialize in (additive, subtractive) and hyperlinks to the equipment they produce. Note: The EX One company manufactures both additive and subtractive manufacturing equipment and is listed in both sections, but it is counted as 1 in the total company count.

Mazak Corporation's parent company is Yamazaki Corporation located in Japan. However they have seven regional headquarters and "technology" centers located throughout the US with their national technology center located in Florence, KY. Amada Machine Tools America is a part of Amada Group which is located in Japan. Their US operations are based in Schaumburg, IL.

**Table 5. Domestic Digital Manufacturing Companies**

Additive Companies			
Company	Location	Technology	Equipment
<a href="#">3D Systems</a>	Rock Hill, SC	Inkjet/3D Printing	3D Printers <a href="#">Projet</a>
		Stereolithography	SLA Series <a href="#">iPro SLA Centers</a> <a href="#">Viper SLA Centers</a>
		Selective Laser Sintering	SLS Series <a href="#">sPro SLS Centers</a> <a href="#">Sinterstation HiQ SLS</a> <a href="#">Sinterstation Pro SLS</a>
<a href="#">EX One</a>	Irwin, PA	Inkjet/3D Printing	<a href="#">ProMetal</a> <a href="#">ProMetal RCT</a>

**Table 5. Domestic Digital Manufacturing Companies (Continued)**

Additive Companies			
Company	Location	Technology	Equipment
<a href="#">Huffman Technologies</a>	Clover, SC	Direct Metal Deposition	<a href="#">HP-115CL</a> <a href="#">HC-205</a>
<a href="#">Objet Geometries</a>	Billerica, MA	Inkjet/3D Printing	<a href="#">Connex 350</a> , <a href="#">Connex 500</a> <a href="#">Eden 250</a> <a href="#">Eden 260V</a> , <a href="#">Eden 350V</a> <a href="#">Eden 500V</a>
<a href="#">Optomec</a>	Albuquerque, NM	Direct Metal Deposition	<a href="#">LENS 850R</a>  <a href="#">Aerosol Jet 300</a>
<a href="#">POM</a>	Auburn Hills, MI	Direct Metal Deposition	<a href="#">DMD 105D</a> <a href="#">Robotic DMD 44R/66R</a>
<a href="#">Solidica (Additive/Hybrid)</a>	Ann Arbor, MI	Ultrasonic Consolidation	<a href="#">Formation™</a>
<a href="#">Solidscape</a>	Merrimack, NH	Inkjet/3D Printing	<a href="#">T612 Benchtop</a>  <a href="#">T76 Plus</a>
<a href="#">Stratasys</a>	Eden Prairie, MN	Fused Deposition Modeling	Production Systems <a href="#">FORTUS 360mc</a> <a href="#">FORTUS 400mc</a> <a href="#">FORTUS 900mc</a>  Prototyping Systems <a href="#">Dimension 1200es</a> <a href="#">Dimension Elite</a> <a href="#">Dimension uPrint</a>
<a href="#">Z Corp</a>	Burlington, MA	3D Printing	3D Printers <a href="#">ZPrinter Series</a>  Prototyping Systems <a href="#">ZBuilder Ultra</a>

**Table 5. Domestic Digital Manufacturing Companies (Continued)**

Subtractive Companies			
Company	Location	Technology	Equipment
<a href="#">Amada Machine Tools America</a>	Schaumburg, IL	CNC Machining	<a href="#">CNC Grinding Machines</a> <a href="#">Amada Wasino Turning Centers</a>
<a href="#">CNC Masters</a>	Irwindale, CA	CNC Machining	<a href="#">CNC 1440 Turning Center</a> Price: Starting at \$9,985 <a href="#">CNC Baron Milling Machine</a> Price: \$6,575 <a href="#">CNC Baron XL Milling Machine</a> Price: \$7,575 <a href="#">CNC Supra Mill</a> Price: Starting at \$9,523 <a href="#">CNC Jr. Table Top Mill</a> Price: Starting at \$5,423 <a href="#">CNC 1340 turning Center</a> Price: Starting at \$8,499
<a href="#">EX One</a>	Irwin, PA	Laser Machining	<a href="#">Luxcellis</a>
<a href="#">Flow International</a>	Kent, WA	Waterjet Machining	<a href="#">Mach 2B</a> <a href="#">Mach 3B</a> <a href="#">Mach 4 B/C/AF/31R Composites Machining Center</a> <a href="#">5 Axis Water Jet System</a>
<a href="#">Haas Automation Inc</a>	Oxnard, CA	CNC Machining	<a href="#">CNC Vertical Machining Center</a> Price Range: \$25,995 - \$320,995 <a href="#">Horizontal Machining Center</a> Price Range: \$89,995 - \$249,995 <a href="#">CNC Turning Center</a> Price Range: \$22,995 - \$169,995 <a href="#">5-Axis CNC</a> Price Range: \$99,995 - \$159,995
<a href="#">JPSA</a>	Manchester, NH	Laser Micromachining	<a href="#">PV-5000</a> <a href="#">IX-3000</a> <a href="#">IX-6100 Series</a> <a href="#">IX-200 Series</a>
<a href="#">Mazak Corporation</a> (Parent Yamazaki Mazak-Japan)	Florence, KY	CNC Machining	<a href="#">CNC Turning Centers</a> <a href="#">CNC Vertical Machining Centers</a> <a href="#">CNC Horizontal Machining Centers</a> <a href="#">CNC Multi-Tasking Centers</a>
<a href="#">Microlution</a>	Chicago, IL	CNC Micromachining	<a href="#">Microlution 5100-S</a> <a href="#">Microlution 353-S</a>

**Table 5. Domestic Digital Manufacturing Companies (Continued)**

Subtractive Companies			
Company	Location	Technology	Equipment
<a href="#">OMAX</a>	Kent, WA	Water Jet Machining	<a href="#">Model 2626/XP</a> <a href="#">Model 2652</a> <a href="#">Model 5555</a> <a href="#">Model 55100</a> <a href="#">Model 60120</a> <a href="#">Model 80160</a> <a href="#">Model 80X Series</a> <a href="#">Model 120X Series</a>
<a href="#">Oxford Lasers</a>	Shirley, MA	Laser Micromachining	<a href="#">A Series, C Series, E Series, G Series, J Series</a>
<a href="#">Resonetics</a>	Nashua, NH	Laser Micromachining	<a href="#">Rapid X 250, 400, 500</a>
<a href="#">SmaTec International</a>	Lisle, IL	Electrical Discharge Machine	Micro EDM Micro Grinding <a href="#">EM203</a> Micro EDM Nano Grinding <a href="#">GM703</a> Micro Machine <a href="#">MM903</a>
<a href="#">WARDJet</a>	Tallmadge, OH	Water Jet Machining	<a href="#">Z-Series(5)</a> <a href="#">J-Series(2)</a> <a href="#">R-Series</a> <a href="#">L-Series</a>

**Foreign Companies**

Research identified 18 foreign companies that produce digital manufacturing equipment. Table 6 is split between companies that manufacture equipment utilizing additive manufacturing processes (nine companies) and those utilizing subtractive manufacturing processes (nine companies). The table contains hyperlinks to each company's website, the technology they specialize in, plus hyperlinks to the equipment they produce.

The technologies in the foreign market are nearly identical to those in the US but there are three additional technologies only available in foreign markets. Three companies, Concept Laser, EOS and MTT Technologies, utilize direct metal laser sintering which is not available in the US. ARCAM, a Swedish company utilizes electron beam melting, also not available in the US. The third technology involves abrasive micro water jet systems. Waterjet AG and Max Daetwyler Corporation of Switzerland formed a partnership to develop the abrasive micro water jet technology. They formed a company called Micro Waterjet, LLC and are located in North Carolina. However, research could not determine if Micro Waterjet, LLC manufacture equipment and conducting research on this technology in the US or if they are just a supplier for the Swiss machines. They therefore were placed in the foreign market.

**Table 6. Foreign Digital Manufacturing Companies**

<b>Additive Companies</b>			
<b>Company</b>	<b>Location</b>	<b>Technology</b>	<b>Equipment</b>
<a href="#">ARCAM</a>	Sweden	Electron Beam Melting	<a href="#">Arcam A1</a> , <a href="#">Arcam A2</a>
<a href="#">Bits from Bytes</a>	UK	Fused Deposition Modeling	<a href="#">BFB 3000</a>
<a href="#">Concept Laser</a>	Germany	Direct Metal Laser Sintering	<a href="#">M1 Cusing</a> , <a href="#">M2 Cusing</a> <a href="#">M3 Linear</a>
<a href="#">Digital Wax Systems</a>	Italy	Stereolithography	<a href="#">DigitalWax 008</a> , <a href="#">DigitalWax 028</a> <a href="#">DigitalWax 029</a>
<a href="#">Envisiontec</a>	Germany	Digital Light Projection	<a href="#">Ultra</a>
<a href="#">EOS</a>	Germany	Direct Metal Laser Sintering  Plastic Laser Sintering  Sand Laser Sintering	<a href="#">EOS 280M</a>  <a href="#">FORMIGA P 100</a> <a href="#">EOSINT P 395</a> , <a href="#">EOSINT P 760</a> <a href="#">EOSINT P 800</a>  <a href="#">EOSINT 750</a>
<a href="#">MTT Technologies</a>	UK	Direct Metal Laser Sintering	<a href="#">SLM 125/250</a>
<a href="#">Phenix Systems</a>	France	Selective Laser Sintering	<a href="#">PXL</a> , <a href="#">PXS</a> <a href="#">PM 100T</a> <a href="#">PM 250</a>
<a href="#">Voxeljet</a>	Germany	Inkjet/3D Printing	<a href="#">VX 500</a> <a href="#">VX 800</a> <a href="#">VX 4000</a>



**Table 6: Foreign Digital Manufacturing Companies (Continued)**

<b>Subtractive Companies</b>			
<b>Company</b>	<b>Location</b>	<b>Technology</b>	<b>Equipment</b>
<a href="#">3D MicroMac</a> Products sold through 3D MicroMac America	Germany	Laser Micromachining	<a href="#">MicroSTRUCT</a> <a href="#">MicroWELD</a> <a href="#">MicroDRILL</a> <a href="#">MicroSIGN</a>
<a href="#">BARON-MAX</a> (Koan Cho Machinery Co)	Taiwan	CNC Machining	Vertical Machining Centers <a href="#">VMC-856</a> , <a href="#">VMC-1066</a> , <a href="#">VMC-1276</a> , <a href="#">VMC-1476</a> , <a href="#">VMC-1688</a>  Horizontal Machining Center <a href="#">HMC-500</a>  Vertical Milling Centers <a href="#">VM-18</a> , <a href="#">VM-20</a> , <a href="#">VM-25</a> , <a href="#">VM-30</a> , <a href="#">VM-35</a>  Graphite Milling Center <a href="#">QM18GS</a>  CNC Rigid Bell Mill <a href="#">BM-430 H</a> , <a href="#">BM-460 H</a> , <a href="#">BM-660 H</a> , <a href="#">BM-760 H</a>  CNC Combi-Lathes <a href="#">KL-1640</a> , <a href="#">KL-1800</a> , <a href="#">KL-2100</a> , <a href="#">KL-2400</a>  Heavy Duty Lathes <a href="#">KL-2600</a> , <a href="#">KL-3000</a> , <a href="#">KL-3200</a>
<a href="#">Doosan</a>	China	CNC Machining	<a href="#">Turning Centers</a> <a href="#">Machining Centers</a> <a href="#">Double Column Machining Centers</a>
<a href="#">Matsuura</a> <a href="#">Muratec</a> <a href="#">Niiqata</a> <a href="#">SNK</a>	Japan	CNC Machining	<a href="#">5 Axis</a> , <a href="#">Horizontal</a> , <a href="#">Vertical CNC</a> , <a href="#">Linear Motor CNC</a> , <a href="#">Multi-Tasking</a> , <a href="#">Gantry Type &amp; Large 5 Axis</a> , <a href="#">CNC and Combination Lathes</a>

**Table 6: Foreign Digital Manufacturing Companies (Continued)**

Subtractive Companies			
Company	Location	Technology	Equipment
<a href="#">Makino</a>	Japan	CNC Machining  Electrical Discharge Machine	<a href="#">Horizontal Machining Centers 4-Axis (29)</a> <a href="#">Horizontal Machining Centers 5-Axis (11)</a> <a href="#">Graphite Machining Centers (5)</a> <a href="#">Vertical Machining Centers (26)</a> <a href="#">Vertical Machining Centers 5-Axis (10)</a>  <a href="#">RAM EDM (17)</a> <a href="#">Wire EDM (10)</a>
<a href="#">Micro Waterjet LLC</a> <a href="#">Max Daetwyler</a>	Switzerland	Abrasive (Micro)Water Jet	<a href="#">Microwaterjet F3</a>
<a href="#">Mori Seiki</a>	Japan	CNC Machining	<a href="#">CNC Lathes (11)</a> <a href="#">Vertical Machining Centers (7)</a> <a href="#">Multi-Axis Turning Centers (3)</a> <a href="#">Horizontal Machining Centers (3)</a>
<a href="#">Posalux</a>	Switzerland	Micro EDM  CNC Machining  Laser Micromachining	<a href="#">HP4-EDM</a> <a href="#">FP1-EDM</a> <a href="#">HP4-Hybrid-EDM</a>  <a href="#">FP1-5CNC</a>  <a href="#">Microfor HP1 Laser</a>
<a href="#">Sarix</a>	Switzerland	Micro EDM	<a href="#">SX-100-HPM</a> <a href="#">SX-200-HPM</a>

## DIGITAL EQUIPMENT MANUFACTURERS FINANCIAL INFORMATION

Financial risk ratings for publicly traded companies are based on an analysis of selected Standard and Poor's financial data for the last five fiscal years, when available. Otherwise, the analysis is based on the company's US Securities and Exchange Commission (SEC) forms (10-K, 8K, 8-Q, etc.) or the company's annual reports.

Financial risk ratings for privately held companies are based on a review and analysis of available credit information using Experian or Dun & Bradstreet databases.

None of the foreign companies were rated for financial risk. Table 7 identifies the criteria used to determine financial ratings.

**Table 7. Criteria Used To Determine Financial Ratings**

<b>Low</b>	Good to strong financial condition. Financial metrics are concentrated at the upper end of the scale. Economic forecasts show continued good to strong performance. Reductions in government contracts would have only a limited impact on viability.
<b>Moderate</b>	Financial condition is stable but sensitive to market conditions. Economic forecasts show relatively consistent performance with some possibility for significant change. Some management corrective action is warranted. Reductions in government contracts could have a negative impact on viability.
<b>High</b>	Financial condition is serious and may indicate a near-term bankruptcy. One or more financial metrics are at or below the critical stage. Market pressures could readily influence this entity. Government intervention is a possibility if a unique technology exists.
<b>Insufficient Data</b>	A search was performed but not enough financial data was found to assign a financial risk rating.

Research revealed the possibility of 22 domestic companies that make equipment utilized in the digital manufacturing industry. Ten of the companies manufacture additive manufacturing type equipment while the other 13 specialize in subtractive manufacturing type equipment. Note: The EX One company manufactures both additive and subtractive manufacturing equipment and is listed in both sections, but it is counted as 1 in the total company count. Also, 18 of the companies are privately held, one (Mazak) is a subsidiary of a foreign company and three companies, 3D Systems, Flow International and Stratasys are publicly held corporations.

Financially, the US sector is healthy. Of the 22 companies, seven were not rated due to insufficient data. Of the remaining 15 companies, 9 were rated low risk, six were given a moderate rating and none were rated high risk. None of the foreign companies were rated for financial risk. Table 8 identifies the financial ratings of the domestic companies in the "additive and subtractive" manufacturing market.

## SOURCES

U.S. Commerce Department's National Institute of Standards and Technology (NIST) – Publications:

<http://www.nist.gov/publication-portal.cfm>

Your Dictionary – Definitions: <http://www.umsl.edu/~sauterv/analysis/jargon.html>

Wikipedia Definitions: <http://en.wikipedia.org>

SLA Descriptions:

<http://www.materialise.com/Stereolithography>

<http://en.wikipedia.org/wiki/Stereolithography>

<http://www.thefullwiki.org/Stereolithography>

<http://www.youtube.com/watch?v=eT-Olz-Jt3w>

SLS Descriptions:

<http://www.mne.psu.edu/lamancusa/rapidpro/primer/chapter2.htm#sls>

[http://en.wikipedia.org/wiki/Selective\\_laser\\_sintering](http://en.wikipedia.org/wiki/Selective_laser_sintering)

[http://rapid-prototyping.harvest-tech.com/selective\\_laser\\_sintering.htm](http://rapid-prototyping.harvest-tech.com/selective_laser_sintering.htm)

<http://www.custompartnet.com/wu/selective-laser-sintering>  
<http://www.youtube.com/watch?v=gLxve3ZOmvc>  
DMLS Descriptions:  
<http://www.custompartnet.com/wu/direct-metal-laser-sintering>  
[http://www.youtube.com/watch?v=C9awF5te\\_2w](http://www.youtube.com/watch?v=C9awF5te_2w)  
DMD Descriptions:  
[http://www.youtube.com/watch?v=iLndYWw5\\_v8](http://www.youtube.com/watch?v=iLndYWw5_v8)  
<http://www.productivitydevelopment.com/92%20Direct%20Metal%20Deposition.pdf>  
FDM Descriptions:  
<http://www.quickparts.com/LowVolumePrototypes/FDM.aspx>  
<http://www.custompartnet.com/wu/images/rapid-prototyping/fdm.png>  
EBM Description:  
<http://wohlersassociates.com/NovDec02TCT.htm>  
<http://www.engineershandbook.com/RapidPrototyping/ebm.htm>  
<http://www.calraminc.com/services.htm>  
Ink Jet Description:  
[http://www.exone.com/eng/technology/x1-prometal/process\\_prometal.html](http://www.exone.com/eng/technology/x1-prometal/process_prometal.html)  
<http://www.voxeljet.de/index.php?id=57&L=1>  
[http://www.objet.com/PRODUCTS/PolyJet\\_Technology/](http://www.objet.com/PRODUCTS/PolyJet_Technology/)  
AWJ and AmWJ Descriptions:  
[http://www.edmtodaymagazine.com/AAweb2\\_2010/TechTips2010/TechTips2009/TechTipsMyJun09.pdf](http://www.edmtodaymagazine.com/AAweb2_2010/TechTips2010/TechTips2009/TechTipsMyJun09.pdf)  
[http://waterjets.org/index.php?option=com\\_content&task=category&sectionid=4&id=46&Itemid=53](http://waterjets.org/index.php?option=com_content&task=category&sectionid=4&id=46&Itemid=53)  
[http://www.micromanu.com/library/75/MM\\_Live\\_5-12-2010.pdf](http://www.micromanu.com/library/75/MM_Live_5-12-2010.pdf)  
EDM Description:  
[http://en.wikipedia.org/wiki/Electrical\\_discharge\\_machining](http://en.wikipedia.org/wiki/Electrical_discharge_machining)  
<http://www.wisegeek.com/what-is-edm.htm>  
LMM Description: <http://whatis.wikidot.com/>  
Skill Sets Required: <http://news.thomasnet.com/>  
Wohlers Report 2010: <http://www.wohlersassociates.com/2010report.htm>  
[http://www.fortus.com/uploadedFiles/North\\_America/Resources/White\\_Papers/Files\\_-\\_White\\_Papers/DDM\\_part2.pdf](http://www.fortus.com/uploadedFiles/North_America/Resources/White_Papers/Files_-_White_Papers/DDM_part2.pdf)  
<http://www.bastech.com/sla/techTips/STLfiles.asp>

## LIST OF ACRONYMS, ABBREVIATIONS, AND SYMBOLS

Acronym	Description
AFRL	Air Force Research Laboratory
Al	Aluminum
AM	Additive Manufacturing
C	Carbon
Ca	Calcium
CAD	Computer Aided Drafting
CAM	Computer Aided Manufacturing
cm	centimeter
CMM	Coordinate-Measuring Machine
CNC	Computer Numerical Control
Co	Cobalt
Cr	Chromium
CT	Computer Tomography
DDM	Direct Digital Manufacturing
DMD	Direct Metal Deposition
DMLS	Direct Metal Laser Sintering
DOD	Department of Defense
DTIC	Defense Technical Information Center
EAR	Export Administration Regulation
EBF3	Electron Beam Free Form Fabrication
EBM	Electron Beam Melting
EB-PVD	Electron Beam Physical Vapor Deposition
EDM	Electro-Discharge Machining
EDS	Energy Dispersive Spectroscopy
ESEM	Environmental Scanning Electron Microscope
FDM	Fused Deposition Modeling
Fe	Iron
GE	General Electric
GUID	Global Unique Identifier
GW	gigawatt
Hz	hertz
IBIC	Industrial Base Information Center
ICCD	intensified charged couple device
in	inch
IR	infrared
ITAR	International Traffic in Arms Regulation
J	Joule

**LIST OF ACRONYMS, ABBREVIATIONS, AND SYMBOLS (Cont'd)**

Acronym	Description
kV	kilovolt
kHz	kilohertz
LENS	Laser Engineered Nets Shaping
LF3	Laser Free Form Fabrication
LSS	Laser Shock Spallation
MATES	Manufacturing Technology Support
Mg	Magnesium
mils	one thousandth of an inch
MLPC	Mound Laser & Photonics Center
mm	millimeters
ms	millisecond
NASA	National Aerospace Space Administration
Ni	Nickel
nm	nanometer
ns	nanosecond
ps	picosecond
PTG	Programmable Timing Generator
Pt	Platinum
RFID	Radio Frequency Identification
RX	Materials & Manufacturing Directorate
RXM	Manufacturing & Technology Division
SEM	scanning electron microscope
sec	second
SLA	Stereolithography
SLS	Selective Laser Sintering
TBC	Thermal Barrier Coatings
TGO	thermally grown oxide
Ti	Titanium
UV	ultraviolet
W	watts
W	Tungsten
WPAFB	Wright-Patterson Air Force Base
wt	Weight
Y	Yttrium
Zr	Zirconium