

# National Centre of Tribology

Risley Nuclear  
Laboratories



UKAEA Risley, Warrington, WA3 6AT





**REPORT DOCUMENTATION PAGE**

Form Approved OMB No. 0704-0188

Public reporting burden for this collection of information is estimated to average 1 hour per response, including the time for reviewing instructions, searching existing data sources, gathering and maintaining the data needed, and completing and reviewing the collection of information. Send comments regarding this burden estimate or any other aspect of this collection of information, including suggestions for reducing the burden, to Department of Defense, Washington Headquarters Services, Directorate for Information Operations and Reports (0704-0188), 1215 Jefferson Davis Highway, Suite 1204, Arlington, VA 22202-4302. Respondents should be aware that notwithstanding any other provision of law, no person shall be subject to any penalty for failing to comply with a collection of information if it does not display a currently valid OMB control number.  
**PLEASE DO NOT RETURN YOUR FORM TO THE ABOVE ADDRESS.**

<b>1. REPORT DATE (DD-MM-YYYY)</b> 31-JAN-1990		<b>2. REPORT TYPE</b> Final Report		<b>3. DATES COVERED (From - To)</b>	
<b>4. TITLE AND SUBTITLE</b> Ultra-Low-Friction Films on Modified Surfaces				<b>5a. CONTRACT NUMBER</b> F49620-87-C-0076	
				<b>5b. GRANT NUMBER</b>	
				<b>5c. PROGRAM ELEMENT NUMBER</b>	
<b>6. AUTHOR(S)</b> B.J. Williams; E.W. Roberts; W.B. Price				<b>5d. PROJECT NUMBER</b>	
				<b>5d. TASK NUMBER</b>	
				<b>5e. WORK UNIT NUMBER</b>	
<b>7. PERFORMING ORGANIZATION NAME(S) AND ADDRESS(ES)</b>				<b>8. PERFORMING ORGANIZATION REPORT NUMBER</b>	
<b>9. SPONSORING/MONITORING AGENCY NAME(S) AND ADDRESS(ES)</b> EOARD Unit 4515 BOX 14 APO AE 09421				<b>10. SPONSOR/MONITOR'S ACRONYM(S)</b>	
				<b>11. SPONSOR/MONITOR'S REPORT NUMBER(S)</b> 1290/626	
<b>12. DISTRIBUTION/AVAILABILITY STATEMENT</b> Approved for public release; distribution is unlimited.					
<b>13. SUPPLEMENTARY NOTES</b>					
<b>14. ABSTRACT</b>					
<b>15. SUBJECT TERMS</b> EOARD, Ultra-Low-Friction Films, MOS2 Film, Film Friction, Film Composition					
<b>16. SECURITY CLASSIFICATION OF:</b>			<b>17. LIMITATION OF ABSTRACT</b> UL	<b>18. NUMBER OF PAGES</b> 118	<b>19a. NAME OF RESPONSIBLE PERSON</b> Surya Surampudi
<b>a. REPORT</b> UNCLAS	<b>b. ABSTRACT</b> UNCLAS	<b>c. THIS PAGE</b> UNCLAS			<b>19b. TELEPHONE NUMBER (Include area code)</b> +44 (0)1895 616021

Prepared for: The European Office of  
Aerospace Research and  
Development.  
223 / 231 Old Marylebone Rd.  
LONDON, NW1 5TH.

Date: 31 January, 1990.

Dept. of Air Force reference: F49620-87-C-0076

ULTRA-LOW-FRICTION FILMS  
ON MODIFIED SURFACES.

FINAL TECHNICAL REPORT.

Report No: 1290/626

Prepared by: B.J.Williams, E.W.Roberts, W.B.Price.

Approved by: W.H.Roberts.

AQ F11-05-0644

20110211274

## SUMMARY

Thin films of molybdenum disulphide produced by the technique of sputtering have been assessed in terms of their friction and wear properties under high vacuum. Improvements in the tribological properties of such films (longer endurances, lower friction) have been realised through the use of hard, ceramic substrate materials; by modifying the surface texture of the substrate to which the film is applied; by laser irradiation of the deposited film; and by modification of the film through ion-beam mixing. Additionally, a "round-robin" exercise has been undertaken in which the properties of MoS<sub>2</sub> films produced by different sources were characterised.

As part of this round-robin exercise, comparative data were obtained on the tribological properties of MoS<sub>2</sub> films produced by three different sputtering techniques, these processes being those developed at three independent laboratories operating either in the UK or USA. These data indicate that 1 micron-thick films, when tested under purely sliding motion at high contact stresses, have durabilities which differ by an order of magnitude and friction coefficients which range from below 0.01 to about 0.03. Thicker films (6 microns) have essentially similar endurances and yield slightly higher friction coefficients. It is further shown, in an extension of the round-robin exercise, that storage of sputtered MoS<sub>2</sub> films under dessicated conditions for up to 12 weeks does not, in general, adversely affect their tribological properties.

It is shown that film friction and durability are profoundly affected by the substrate material to which the film is applied. Thus MoS<sub>2</sub> films deposited on hot-pressed silicon nitride have appreciably longer endurances and lower friction than similar films applied to metallic substrates. Models are presented which explain the observed variations in friction and durability in terms of the mechanical properties of the substrate and film-to-substrate adhesion respectively.

Results are presented which demonstrate that improvements in film performance are obtained through surface, interface and bulk modifications. Specifically it is shown that for both metallic and ceramic substrate materials the tribo-properties of 1 micron-thick films can be optimised by tailoring the surface roughness of the substrates. Thus for example, films applied to steel substrates of surface roughness 0.2 micron CLA have durabilities which are one order of magnitude greater than those of similar films applied to highly polished (<0.05 micron CLA) steel substrates.

It is further demonstrated that the subjection of thin (0.2 micron) films to bombardment by energetic (40keV) nitrogen ions enhances film durability whilst film friction remains unaffected. Such a process compacts the film by up to 50% but does not change film composition. Similar studies made on films



treated by laser irradiation indicate that such processing can effect a reduction in film friction during the initial stages of running. It is surmised that laser processing, at the energies and fluxes examined, modifies only the surface layers of MoS<sub>2</sub> films thereby confining an improved film performance to a small fraction of the overall film lifetime.

## Contents

1. Introduction
2. Description of Tasks Undertaken
  - 2.1 The "Round-Robin" Exercise - Storage Effects
    - 2.1.1 Background
    - 2.1.2 Approach
    - 2.1.3 Test Apparatus
    - 2.1.4 Results and Discussion
    - 2.1.5 Conclusions
  - 2.2 The Effects of Surface Roughness
    - 2.2.1 Introduction
    - 2.2.2 Test Procedure and Samples
    - 2.2.3 Results
    - 2.2.4 The anomalous failure of MoS<sub>2</sub> films on silicon nitride.
    - 2.2.5 Conclusions
  - 2.3 Laser Treatment Study
    - 2.3.1 Introduction
    - 2.3.2 Test Samples and Procedure
    - 2.3.3 Laser Processing
    - 2.3.4 Results and Discussion
    - 2.3.5 Conclusions
  - 2.4 Ion Beam Mixing of Molybdenum Disulphide Films.
    - 2.4.1 Introduction



- 2.4.2 Stainless Steel Coupons
- 2.4.3 Bearing Steel Thrust Washers
- 2.4.4 Summary

3. Implications of Results with Regard to Scale-Up of ULF Technology to Component Level.

4. Acknowledgements

5. References

Appendix 1 - Professional personnel associated with project.

Appendix 2 - Meetings Attended.

Appendix 3 - MoS<sub>2</sub> Coatings Prepared under this contract at N.C.T. for U.S. Companies.

Appendix 4 - Annual Technical Report 1488/531

Appendix 5 - Annual Technical Report 1189/581

## 1. Introduction

This part of the report details work undertaken in the period 1 May 1989 to 31 Jan 1990 under contract No. F49620-87-C-0076 entitled "Ultra-low-friction films on modified surfaces".

Reports on work undertaken previously under this contract can be found in Appendices 4 and 5. In these, the work reported on comprised the procurement, installation and optimisation of an R.F. magnetron sputter-deposition rig; the comparative testing of thin MoS<sub>2</sub> films produced by different suppliers both in the U.K. and the U.S.A.; and an investigation into the performance of sputtered MoS<sub>2</sub> films when applied to various substrate materials. In addition, NCT was contracted to prepare a review of current trends in European Space Tribology (NCT report 988/526).

We present here a continuation of the above work. This comprises the following activities:

- a) An examination into the effects of controlled storage on the tribological performance of sputtered MoS<sub>2</sub> films produced in the U.K./U.S.A. "Round-Robin" exercise.
- b) An investigation into how the tribological performance of sputtered MoS<sub>2</sub> films is dependent upon the surface roughness of different underlying substrates.
- c) A study of the effects of surface modification by laser irradiation and the effects of bulk and interface modifications by ion implantation on the lubricity and durability of sputtered MoS<sub>2</sub> films.

The principal aim of the work presented was to examine ways of effecting improvements in film friction and durability.



## 2. Tasks Undertaken

### 2.1 The "Round-Robin" Exercise - Storage Effects

#### 2.1.1 Background

The "round-robin" exercise was initiated in July 1987. Its purpose was to characterise and compare the tribological properties of molybdenum disulphide films produced by different sputtering techniques at different establishments.

These establishments and their respective deposition techniques are as follows:

National Centre of Tribology (NCT), UK: magnetron sputtering.

Aerospace Corporation, USA: RF sputtering.

Hohman Plating, USA: DC triode sputtering.

NCT's role in the round-robin exercise was to test, under high vacuum conditions, MoS<sub>2</sub> films produced by the above companies. In addition NCT were to supply magnetron-sputtered films of MoS<sub>2</sub> to all participants, these being the above named companies together with NRL, Washington and Sandia National Labs, for testing and analysis.

In the first round of the exercise MoS<sub>2</sub> films were deposited on steel substrates to two thicknesses: 1 and 6 microns. The results of tests undertaken at NCT have been presented in the two previous Annual Technical Reports (Appendices 4 and 5). Briefly, these tests indicated that whilst all films examined gave rise to low friction (0.007 to 0.044) under high vacuum, there did occur differences in performance according to the deposition technique employed. Further it showed that increasing film thickness from 1 to 6 microns brought about only modest increases in film durability.

In the second round of the exercise the effect of storage on the friction and wear of sputtered MoS<sub>2</sub> films was assessed. The purpose of this study was to determine whether MoS<sub>2</sub> films could deteriorate during the storage periods and transportation time inevitably incurred during round-robin sample exchanges. We report below the results of "storage-effect" tests undertaken at NCT.

#### 2.1.2 Approach

The intention was to test films from the same batch on the same day at two or more of the participating laboratories. After deposition, substrates were to be stored, as well as shipped, in desiccated bags. Friction and endurance tests would then be undertaken over three months according to the following schedule:

Test No. 1: day 1 (depositor's laboratory only)

Test No. 2: three weeks from date of deposition (day 21)  
Test No. 3: twelve weeks from date of deposition (day 84)

All the films tested at NCT were deposited to a thickness of 1 micron on discs manufactured from 52100 bearing steel. These films were those produced at NCT by magnetron sputtering and at Hohman Plating by DC triode sputtering.

### 2.1.3 Test Apparatus

The standard NCT pin-on-disc rig was used to perform friction tests on the sputter-coated MoS<sub>2</sub> films after the specified storage periods. A full description of the pin-on-disc apparatus, together with photographs and schematic diagrams, can be found in Appendix 4. To allow a direct comparison of results, the same conditions were used as on previous tests in this programme ie:

Total Applied Load = 80N load,  
Rotational Speed = 400 rpm,  
Chamber Pressure =  $< 5 \times 10^{-7}$  torr.

### 2.1.4 Results

The results from the storage study tests for the NCT and Hohman samples as tested on the NCT pin-on-disc apparatus are shown in Figures 1 and 2 respectively.

Fig.1 indicates that under the specified test conditions, NCT films have an endurance in the order  $10^5$  disc revs. regardless of storage time. Following some 2-3000 disc revolutions all films show a similar pattern of behaviour in that they exhibit low friction (friction coefficient = 0.015), a condition which is maintained until the onset of film failure. Up to 3000 disc revolutions however there is a notable difference in film behaviour. The films subjected to storage periods of three weeks or less exhibit low friction throughout whereas the film stored for 12 weeks yielded significantly higher friction (friction coefficient up to 0.04).

Tests on the Hohman films (Fig.2) show that stored films exhibit a durability in the order  $10^4$  disc revolutions (clearly day 1 tests could not be undertaken on these films due to shipping time). As with the NCT films the overall behaviour of the films is similar and there occurs a noticeable difference in the early stages of testing. Again, the film stored for 12 weeks exhibits higher friction (friction coefficient of 0.035) on initial running. After some 1000 disc revolutions the friction coefficient has reduced to 0.025 and remains at about this level until the film fails.

Our results indicate that the only discernible effect of storage is to increase the initial value of friction coefficient of



sputtered MoS<sub>2</sub> films. The most likely explanation of this effect is that the surface layers of the MoS<sub>2</sub> films become gradually oxidised and that the oxidised layer confers a higher friction. This seems feasible since at room temperature MoS<sub>2</sub> reacts slowly with oxygen to form MoO<sub>3</sub>, and oxidised MoS<sub>2</sub> has been shown to give rise to increased friction (see for example Ref. 1, in which MoS<sub>2</sub> films oxidised with atomic oxygen exhibited a fivefold increase in friction coefficient). Because of the slow reaction rate such an effect would be confined to the uppermost layers of the MoS<sub>2</sub> films. This is consistent with our observation that the higher friction persists for a few thousand disc revolutions only. In the case of NCT films, for example, this higher friction is maintained for a period corresponding to the initial 2% of the film's lifetime. Making the, admittedly crude, assumption that the film wears linearly with sliding distance, this would indicate that NCT films become oxidised to a depth of about 200 Angstroms.

### 2.1.5 Conclusions

Our results point to three main conclusions:

- a) up to 12 weeks of dry storage does not affect the durability of MoS<sub>2</sub> films produced by sputtering (at NCT and Hohman Plating).
- b) the initial friction coefficient displayed by both the NCT and Hohman films is higher after 12 weeks of dry storage.
- c) the friction coefficient of stored films reduces to low, stable values after an initial running-in period of up to 3,000 disc revolutions.

## 2.2 The Effects of Surface Roughness

### 2.2.1 Introduction

We present here the results of an examination of the effect of the surface roughness of the substrate on the tribological properties of sputtered MoS<sub>2</sub> films. This work is a continuation of that reported in the last Annual Technical Report (Appendix 5) wherein thin films of MoS<sub>2</sub> were applied to a range of four different substrate materials, namely:

52100 bearing steel,  
440C stainless steel,  
IMI318 titanium alloy  
Hot-pressed silicon nitride (HPSN).

In that study the surface roughnesses of the substrates were deliberately kept the same (about 0.04 microns CLA). The study concluded that:

a) the friction coefficient decreased with increasing elastic modulus of the contact (substrate) materials - such that film friction was lowest for films applied to silicon nitride and highest for films applied to titanium alloys.

b) film durability was highly sensitive to the substrate material to which the film was applied. The greatest film endurance was observed on films deposited on silicon nitride and the poorest endurance observed when titanium alloy was used as the substrate.

c) film durability appeared to be related strongly to film adhesion - as evidenced by the presence of interfacial chemical bonds on the steel and ceramic samples but not on the titanium alloy specimens.

The purpose of the present study was to apply MoS<sub>2</sub> films to similar substrates but having different surface roughnesses or textures. The main aim was to determine whether an optimum value of surface roughness existed at which film durability was maximised.

### 2.2.2 Test Procedure and Samples

Three of the four materials listed in section 2.2.1 were used in the study, these being HPSN, 52100 and IMI318. Ring samples were prepared from the chosen materials and then polished/ground to produce surface roughnesses of nominally 0.04, 0.12, 0.25 and 0.40 microns CLA. Vickers Hardness measurements were taken of each sample before and after grinding so as to detect any work-hardening of the sample surface. Each sample was then coated with "high-rate" MoS<sub>2</sub> (NCT process) to a thickness of 1 micron and tested in vacuum on the NCT pin-on-disc apparatus. Tests were



undertaken at a rotational speed of 400 rpm and an applied load of 50 Newtons. In each test the pin material was made the same as that of the substrate, the pins in each case being highly polished to a finish better than 0.05 microns CLA.

A complete list of the prepared substrates used in these tests is shown below (Table A) together with the results of the hardness and surface roughness measurements.

\*\*\*\*\*

Table A  
SURFACE ROUGHNESS SAMPLES

SAMPLE NUMBER	SURFACE ROUGHNESS GROUP	MATERIAL TYPE	HARDNESS		ROUGHNESS	
			Before polishing	After polishing	Before polishing	After polishing
1	0.04	HPSN	1992	1878	0.047	0.047
2		52100	730	660	0.084	0.043
3		IMI318	324	315	0.340	0.045
4	0.12	HPSN	1992	1874	0.047	0.128
5		52100	----	----	0.085	0.120
6		IMI318	321	315	0.406	0.110
7	0.25	HPSN	1992	1995	0.047	0.210
8		52100	710	710	0.100	0.240
9		IMI318	320	310	0.300	0.220
10	0.40	HPSN	1992	1925	0.047	0.350
11		52100	710	700	0.082	0.380
12		IMI318	310	323	0.560	0.390

\*\*\*\*\*

It can be seen from Table A that no significant changes in surface hardness were induced as a result of the machining process.

### 2.2.3 Results

Pin-on-disc results presenting friction coefficient plotted against number of disc revolutions at given surface roughnesses can be seen in figures 3 to 5. The results have been translated into graphs which illustrate the effects of surface roughness on endurance and friction coefficient for the three materials tested. These can be seen in figures 6 to 8. In each figure film durability represents the number of disc revolutions completed at the point at which the friction coefficient had increased to a value of 0.1.

Figure 3 shows the friction and endurance traces for MoS<sub>2</sub> applied to 52100 bearing steel. Apart from the film applied to the most polished surface (CLA 0.043 micron), the traces exhibit low, steady values of friction coefficient until the onset of failure. Fig.6 summarises these results and shows that film durability varies by over an order of magnitude within the range of substrate roughnesses examined. There appears to be an optimum value of surface roughness corresponding to a CLA value of about 0.2 microns at which the film endurance is maximised. Friction coefficient is seen to decrease initially with increasing roughness of substrate. At surface roughnesses exceeding 0.1 micron the friction appears stable, having values in the order 0.01.

These results may have important implications as regards the lubrication of steel ball bearings with sputtered MoS<sub>2</sub>. Precision bearings, which are commonly used on spacecraft mechanisms, have raceway and ball surface finishes of 0.05 microns or better. The above suggests that such finishes are not ideal for MoS<sub>2</sub> film lubrication and that improved performances might be obtained if the bearing surfaces were textured to give an optimum tribological performance. Thus if the advantages of texturing as demonstrated in our pin/disc tests were directly transferable to bearings (and this remains to be demonstrated) we might expect to see bearings performing with lower mean torque and torque noise (as a result of lower film friction) coupled with tenfold improvements in low-torque lifetime.

Figs. 4 and 7 show the results of the silicon nitride tests. It can be seen that there is an order of magnitude difference in the durabilities of the samples tested with the higher durabilities occurring at the higher values of surface roughness examined. Although by no means as clear cut as in the case of the MoS<sub>2</sub>/steel combination there appears to be a maximum durability at roughnesses of between 0.2 and 0.3 micron. The friction coefficient increases with increasing surface roughness and ranges from ultra-low friction (<0.01) on highly polished surfaces to between 0.02 and 0.04 on roughened substrates. A notable feature of the behaviour of MoS<sub>2</sub> films on hot-pressed silicon nitride is that film failure does not occur catastrophically. That is, it occurs gradually and can even recover its low-friction properties before complete failure (see Fig. 4). This aspect will be discussed later.

Figs. 5 and 8 reflects the inferiority of MoS<sub>2</sub> films in combination with titanium alloy when compared to the other material combinations tested, as previously reported in ATR 1189/581. Within the range of surface roughnesses examined, the samples experienced an order of magnitude increase in film endurance and a three-fold reduction in friction coefficient. Therefore, despite this relative inferiority, there is still a strong dependence of film endurance and lubricity on the surface roughness of the underlying substrate.



#### 2.2.4 The anomalous failure of MoS<sub>2</sub> films on silicon nitride.

The failure of sputtered MoS<sub>2</sub> films applied to metals such as bearing steels and titanium alloys has been shown to occur rapidly and catastrophically as evidenced by a sudden rise in friction coefficient to values exceeding 0.1. In our previous report (Appendix 5) it was noted that MoS<sub>2</sub> films applied by sputtering to polished substrates of HPSN fail more gradually in that the increase in friction coefficient upon the onset of film failure is not sudden. Furthermore it was observed that some film recovery took place after "failure" in that having exceeded 0.1, the film friction coefficient reduced to levels of about 0.05. Gradual film failure was ascribed to the porous nature of the silicon nitride surface which, it was argued, could retain reservoirs of MoS<sub>2</sub> in the surface pores which could in turn supply lubricant to the interface once the bulk of the film had worn through. This mechanism of film wear is depicted schematically in Fig. 9.

In our present studies the phenomenon of film recovery has again been observed with MoS<sub>2</sub> applied to HPSN. This effect is clearly demonstrated in the friction trace of MoS<sub>2</sub> applied to HPSN substrates having a surface roughness of 0.35 micron CLA. For greater clarity the aforementioned trace has been replotted on a linear scale and emphasis has been placed on the regions of friction excursion (figure 10). The specimen experienced large, dramatic increases in friction coefficient, followed by long periods of relatively low, stable values of friction (friction coefficients about 0.03). The frequency and magnitude of the friction excursions appeared to increase with increasing number of disc revolutions until the point where the test was terminated (thus being done at the operator's discretion). It should be noted that whilst film failure, according to our definition, occurs following 750,000 disc revs., effective lubrication continues for a considerably longer period.

Whilst the retention of MoS<sub>2</sub> in surface pores may help explain the gradual nature of increases in film friction it does not, at first examination, account for the lengthy periods of low, stable friction that characterise film recovery. One possible explanation may as follows. On initial wear-out of the film (stage b, Fig.9) the pin slides on a honeycomb of HPSN and MoS<sub>2</sub>. The friction consequently increases because the film is now discontinuous. On further sliding MoS<sub>2</sub> is transferred from the surface pores to the pin counterface so as eventually to form a continuous transferred layer. At this point the friction is reduced to low stable values. Film friction again increases upon wear-out of this transferred film. Thereafter the process is repeated until there exists no further supply of MoS<sub>2</sub> (Stage c, Fig. 9).

### 2.2.5 Conclusions

Our results point to the following conclusions:

Film friction and durability are strongly dependent upon the surface roughness of the underlying substrate.

On increasing the surface roughness of the bearing steel and hot pressed silicon nitride substrates, the endurances of the deposited films exhibit maxima which correspond to optimum values of surface roughness for each material. MoS<sub>2</sub> films applied to titanium alloy have endurances which are inferior to those of films applied to steel and silicon nitride substrates.

When applied to metal surfaces MoS<sub>2</sub> film friction is observed to decrease with increasing surface roughness. The converse is true of films applied to HPSN in that film friction increases linearly with surface roughness.



## 2.3 Laser Treatment Study

### 2.3.1 Introduction

Pulsed laser processing of sputtered MoS<sub>2</sub> films using excimer radiation can induce changes in film morphology whilst leaving film density and stoichiometry relatively unaffected (Ref.2). Preliminary measurements made elsewhere (Ref.3) have indicated that films thus treated exhibit lower friction in both air and high vacuum.

In the tests reported here the in-vacuo tribological properties of sputtered molybdenum disulphide films have been examined before and after laser treatment. The effect of laser irradiation on the "dwell" effect was also investigated. The dwell effect is a phenomenon which has been observed and documented by NCT, and which concerns increases in the initial (re-start) friction of magnetron sputtered MoS<sub>2</sub> films following periods of inactivity (i.e no sliding) in vacuum. This effect has been attributed to adsorption of small (possibly sub-monolayer) quantities of water (Ref. 4) which increase the shear strength of molybdenum disulphide and hence increase friction. Upon sliding, the friction coefficient is thus initially higher but decreases with continued sliding - probably as a result of the removal of contaminated MoS<sub>2</sub> layers or by desorption of water molecules.

### 2.3.2 Test Samples and Procedure

NCT and Hohman Plating produced coatings on a total of six standard 52100 bearing steel thrust washers. The samples were identified as follows:

NCT/LP/A		1 micron MoS <sub>2</sub>	
NCT/LP/B		NCT "High-rate"	
NCT/LP/C		RF magnetron sputtering.	
HP/LP/A		1 micron MoS <sub>2</sub> + Ni	Hohman Plating
HP/LP/B		1 micron MoS <sub>2</sub>	
HP/LP/C		1 micron MoS <sub>2</sub>	DC sputtering.

The samples denoted "/A" and "/B" were subjected to the normal "run until failure" testing procedure as with previous experiments. The samples were tested in vacuum on the NCT pin-on-disc apparatus under a load of 80N and at a rotational speed of 400 rpm. This gave results against which any effects attributable to the laser treatment could be compared.

The samples denoted by "/C" were used in tests designed to examine the behaviour of the films when subjected to increasing amounts of "dwell-time". For the purposes of these experiments the samples (NCT/LP/C and HP/LP/C) were tested in vacuum at a rotational speed of 60 rpm under an applied load of 20 Newtons.



The films were run-in initially to obtain steady torque values and then were subjected to increasing amounts of dwell-time as the drive motor was stopped for periods of up to 70 hours. After the designated dwell-time had elapsed, sliding motion was resumed and the friction coefficient measured, together with the time taken for the friction to decrease to levels attained following running-in. This period is referred to as the "recovery time" of the film.

### 2.3.3 Laser Processing

All laser processing was carried out at Los Alamos National Laboratory under the direction of Dr Tom Jervis. The processing equipment is shown in Figure 11 and comprises:

- (a) an excimer laser, generating radiation at 248nm at a fluence of  $0.1 \text{ Jcm}^{-2}$ ,
- (b) a homogeniser which produces a beam of uniform spatial intensity,
- (c) a motorised sample fixture which enables the sample to be rotated through the laser beam.

The samples were treated with nominally 2 pulses/position of excimer laser. They were rotated through two revolutions in front of a beam spot of area  $0.84 \text{ cm}^2$  at a repetition rate of 4.4 Hz. This gave a characteristic "burn" pattern on the discs which can be seen in figure 11.

### 2.3.4 Results

After the laser treatment, the samples were returned to NCT and tested under high vacuum on a pin-on-disc apparatus. Results for the NCT and Hohman samples before and after laser treatment can be seen in figures 12 - 21.

Figure 12 shows the friction and endurances of four samples before laser treatment. It can be seen that, after the initial running-in period of some 1000 disc revolutions, the NCT films exhibit lower friction coefficients and longer endurances than the Hohman films. The initially high friction observed on NCT sample A(1) is attributed to an oxidised surface arising possibly as the result of storage (see for example section 2.1.4).

The effects of the laser irradiation can be seen in figure 13. The average friction coefficients of all the samples under test are lower after laser treatment, the most marked differences being found during the initial stages of the test where friction coefficients are generally lower.

Traces for each sample comparing the "before" and "after" tests for the run-until-failure tests are presented in figures 14 - 17. These indicate that, in the case of NCT films, laser processing effects a significantly lower friction during the first two thousand disc revolutions - an amount equivalent to about 2% of film lifetime. Film durability however is reduced.

In the case of Hohman films, laser processing induces lower friction for a longer period - some 5000 disc revs. and equivalent to about 15% of film lifetime. The durability of Hohman films was unaffected by laser processing.

From the above results it would seem that the laser treatment has a finite depth of penetration and that any structural and compositional changes effected by it are confined to the uppermost layers of the MoS<sub>2</sub> films. This is consistent with the use of very short wavelength radiation which results in shallow absorption depths.

The results from the "dwell-time" experiments for the NCT and Hohman samples can be seen in Figures 18-21. Fig. 18 shows the results relating to an NCT film prior to laser irradiation. Dwell periods of up to 1000 secs. do not affect the starting friction. For longer dwell periods the friction coefficient is increased, the initial friction coefficient being about 0.05 following dwell period of 100,000 secs. After laser irradiation (Fig.19) the dwell effect is maintained and indeed may even be enhanced inasmuch as a change in initial friction is observed following 1000 secs. of dwell whereas none was seen on films exposed to this dwell period prior to laser treatment.

Whereas little change was observed with NCT films, the dwell properties of Hohman films were greatly modified following laser treatment. The properties of Hohman films prior to laser irradiation were however quite unlike those exhibited by NCT films - as can be seen in Fig.20. As with NCT films there is little or no change in friction following dwell periods of up to 100 secs. For longer periods changes do occur but in a complicated manner such that these can be either increases or decreases in starting friction. With further sliding the friction coefficient drops, passes through a minimum and then rises to the run-in value. Fig. 21 shows the results of a similar experiment made on the same Hohman film following its exposure to laser radiation. Two effects are seen. First, the dwell effect is now manifested in a way which closely resembles that observed with NCT films and secondly the value of the run-in, friction coefficient is much reduced (from about 0.06 to 0.01).

Whilst an explanation of these effects remains to be found it seems clear that one effect of laser irradiating Hohman films is to render their frictional properties consistent with those of NCT films.



### 2.3.5 Conclusion

Samples of thin MoS<sub>2</sub> films supplied by NCT and Hohman Plating have been subjected to excimer laser radiation. Our results point to the following conclusions:

- 1) Laser irradiation improves, i.e. reduces, the initial friction coefficient conferred by MoS<sub>2</sub> films - the magnitude of this decrease being greater for Hohman films than for NCT films. It is surmised that the laser depth penetration is limited and as such any benefits of this nature are confined to the film's outermost layers.
- 2) Film endurance is not increased by laser irradiation.
- 3) Laser irradiation does not suppress the so-called "dwell-effect" as demonstrated by NCT films. Hohman films show a peculiar dwell effect which is rendered similar to that of NCT films following laser irradiation.

## 2.4 Ion Beam Mixing of Molybdenum Disulphide Films.

### 2.4.1 Introduction.

The bombardment of thin films of molybdenum disulphide by high energy inert gas ions (up to 400 keV) has been shown to bring about atomic mixing of the film/substrate interface together with compaction of the film (Refs. 5-7). As a result of ion-bombardment, film durabilities are considerably enhanced whilst frictional properties appear to remain unaffected.

The object of this study was to investigate the effects of ion beam mixing on the tribological properties of thin MoS<sub>2</sub> films produced by magnetron sputtering. The aim was to improve the lubricity and durability of the films.

### 2.4.2 Stainless Steel Coupons.

#### Experimental Procedure.

Experiments were first carried out with the ion beam mixing of thin molybdenum disulphide films applied to stainless steel coupons. The aim of this part of the study was to investigate the effect of ion bombardment, at different doses, on the composition and density of magnetron sputtered MoS<sub>2</sub> films.

Thin (nominally 0.25 microns) films of MoS<sub>2</sub> were deposited by magnetron sputtering using the NCT apparatus onto polished stainless steel discs of diameter 15 mm. The film thickness was chosen to match approximately the projected range for 40keV N<sup>+</sup> ions.

Ion beam mixing of the films was carried out with a Lintott ion implanter at the University of Salford, Centre for Thin Film and Surface Research, (UK). A 20uA beam of 40keV N<sup>+</sup> ions at room temperature in a target chamber pressure of 10<sup>-6</sup> torr was used to perform the implantation. The ion doses used on different discs were 1 x 10<sup>15</sup>, 3 x 10<sup>15</sup>, 5 x 10<sup>15</sup>, 1 x 10<sup>16</sup> and 2 x 10<sup>16</sup> ions/cm<sup>2</sup>. In each case half of the disc surface was masked from the ion beam, to provide a "control" for analysis using RBS, and to allow a Talysurf (film thickness) measurement at the boundary between the "bombarded" and untreated regions of the MoS<sub>2</sub> film.

After ion beam bombardment, both halves of each disc were analysed by Rutherford Backscattering Spectroscopy (RBS) using a 2 MeV beam of He ions incident normal to the film surface and a scattering angle of 168 degrees. This technique would reveal any compositional changes, and indicate the amount of sputtering which could occur during N<sup>+</sup> irradiation. The boundaries between the bombarded and unbombarded halves of the films were examined by a Talysurf to evaluate the amount of compaction that may have occurred during irradiation.



## Results

Examination of the discs after the ion bombardment showed a dramatic difference in visual appearance between the irradiated and non-irradiated halves of the MoS<sub>2</sub> films. Whilst the as-deposited films were brownish in colour, the bombarded films looked "metallic" and shiny. This effect was least pronounced for the sample with the lowest ion dose.

Figures 22 (a) - (e) show the RBS spectra for the bombarded discs with the spectra for the unbombarded halves of each disc superimposed for comparison. The general conclusions from the RBS data were as follows:

- 1) The composition of the film appeared to be about MoS<sub>1.75</sub>
- 2) The films were pure, clean and free from any oxidation or contamination.
- 3) Ion beam bombardment of the films did not result in any measurable sputtering or change in composition. In fact the thickness change by sputtering was comparable to the variation of the film thickness across each disc. The RBS data showed very little change between the bombarded and unbombarded halves of the discs.

The Talysurf measurements on these discs showed quite a considerable difference in thickness. The result for the disc implanted by  $2 \times 10^{16}$  ions/cm<sup>2</sup> of N<sup>+</sup> is shown in figure 23. The reduction in thickness for this film is estimated to be equal to a compaction of about 50%. Apart from the film treated with a dose of  $10^{16}$  ions/cm<sup>2</sup> film, which is not considered to be reliable because of an apparent variation in its initial film thickness, all films underwent compaction - the amount of which increased with N<sup>+</sup> dose. Precise measurements on these other samples were not possible because the surface roughnesses of the substrates supplied by Salford University were comparable with the compaction of the film caused by the ion bombardment.

## Conclusions

Thin (0.25µm) films of MoS<sub>x</sub> were bombarded with 40 keV N<sup>+</sup> ions to doses in the range  $10^{15}$  to  $2 \times 10^{16}$  ions/cm<sup>2</sup> at room temperature. The composition of these films was approximately MoS<sub>1.75</sub>. The changes occurring as a result of ion bombardment were:

- 1) A significant change in the appearance of the films, from a dull brown to a shiny metallic finish.
- 2) A compaction of the film by about 50% at the highest ion dose used. It was established that this was not due to sputtering of the film.

3) There was no measurable change in the composition of the film.

These changes are consistent and in good agreement with similar effects reported by Kobs et al (Ref 7).

### 2.4.3 Bearing Steel Thrust Washers

#### Experimental Procedure

Following the successful ion beam mixing with the coupons, it was decided to attempt a comparative tribological test on the NCT "high rate" MoS<sub>2</sub> applied to 52100 bearing steel. Results from pin-on-disc tests before and after ion bombardment were to be compared in order that the effects of ion beam mixing on the friction and endurance of the films could be established.

An as-received 52100 thrust washer with a surface roughness of 0.041 micron CLA was coated with a 0.2 micrometre thick film of magnetron sputtered MoS<sub>2</sub>. The coating thickness was again chosen to approximately match the projected range for the 40 keV N<sup>+</sup> ions. The pin on disc friction/wear tests were performed using the following conditions:

Applied Load	=	50 Newtons.
Rotational Speed	=	400 revs per minute.
Chamber Pressure	=	< 5 x 10 <sup>-7</sup> torr.

The inner race track (diameter 60 mm.) was used for the test prior to ion beam mixing. On completion of the test, defined arbitrarily as the point where the friction coefficient exceeded 0.3, the ring was subjected to ion beam mixing.

Based on the results of the previous "coupon" study, Salford University carried out nitrogen ion beam bombardment using a dose of 2 x 10<sup>16</sup> ions/sq.cm. of 40 keV N<sup>+</sup> ions. Inspection of the disc after ion beam mixing again revealed an apparently "metallic" appearance. The disc was returned to NCT and tested on the pin-on-disc machine, using the same parameters as the previous test, except that in this case the outer race track (diameter 66mm.) was used.

#### Results

Figure 24 illustrates the effect of ion beam mixing on the sample. It can be seen that after ion beam mixing, the endurance of the film has increased significantly, from 24,000 to 63,000 disc revolutions. It is observed that nitrogen ion bombardment has not adversely affected the lubricity of the film, the bombarded film having the same low, steady value of friction coefficient (approx 0.011) as the unbombarded film.



## Conclusions

Preliminary tribological tests on ion-bombarded films of molybdenum disulphide indicate that:

- a) Ion beam mixing using  $N^+$  ions leads to an almost three-fold increase in film endurance.
- b) The friction coefficient of the film remains unaffected by ion-beam mixing.

### 2.4.4 Summary

Ion bombardment on thin magnetron sputtered films by 40 keV nitrogen ions produces the following effects:

- a change in the visual appearance of the film, from a dull finish to one which is shiny and metallic.
- film compaction, giving rise to increases in density of up to 50% at the higher ion doses examined.
- no change in film composition, which RBS indicates to be  $MoS_{1.75}$ .
- a significant increase in film durability whilst maintaining low friction (friction coefficient 0.01).

### 3. Implications of Results With Regard To Scale-Up Of ULF Technology to Component Level.

The principal aim of the present work was to examine and develop ways of improving the in-vacuo tribological properties of sputtered films of molybdenum disulphide. It has been shown that improvements in film durability can be gained by suitable choice of substrate material; by optimising the surface roughness of the substrate; and by subjecting the deposited film to bombardment by energetic inert gas ions. Furthermore, it has been demonstrated that reductions in friction can be effected by laser irradiation of the film and through texturising the substrate surface. All these improvements have been demonstrated at a research level in experiments in which films have been assessed under purely sliding motion. Thus the aim of the work as defined above has, at an experimental level, largely been achieved.

In practice such films will be applied to tribological components. In particular, interest is centred on the application of such films to high precision ball bearings. Since in dry lubricated ball bearings the Coulombic torque is strongly influenced by the sliding friction coefficient, lower-friction films should give rise to lower mean torque levels and lower torque noise. Additionally, higher-durability films should greatly increase the low-torque lifetime of bearings.

Our results therefore indicate that improved bearing performance should result from transfer of ULF-film technology to the component level. In particular they imply that:

- the performance of sputtered MoS<sub>2</sub> on steel ball bearings would be improved by a) texturising the raceway surface prior to film deposition b) laser irradiation of MoS<sub>2</sub> applied to raceways and balls and c) ion-beam mixing of films applied to bearing surfaces.

- ceramic bearings lubricated with sputtered MoS<sub>2</sub> should give lower torques and longer lifetimes than similarly treated steel bearings.

Future work should address the practicability of undertaking the above modifications to dry-lubricated ball bearings. It will be the effective transfer and application of these technologies that will ultimately determine the success of the programme.



#### 4. References

1. J B Cross, J A Matin, L E Pope and S L Konntz "Atomic oxygen - MoS<sub>2</sub> chemical reactions" Proc. ICMC, San Diego, April, 1989.
2. T R Jervis et al "Laser surface processing of molybdenum disulphide thin films" to be published in Thin Solid Films, 1990.
3. private communication with T Jervis and L Pope.
4. E W Roberts "The lubricating properties of magnetron sputtered MoS<sub>2</sub>" ESA (ESTL) 76, 1987.
5. Chevallier et al "Enhancement of sliding life of MoS<sub>2</sub> films deposited by combining sputtering and high energy ion implantation" Appl. Phys. Lett. 48, 13, March 31, 1986.
6. Kobs et al "Improved tribological properties of sputtered MoS<sub>x</sub> films by ion beam mixing" Appl. Phys. Lett. 49, 9, Sept.1, 1986.
7. Kobs et al "Enhanced endurance life of sputtered MoS<sub>x</sub> films on steel by ion beam mixing" Materials Science and Engineering 90, 281-286, 1987.

## 5. Acknowledgements

The authors gratefully acknowledge the work of the following people:

Mr. Francis Goater of NCT for carrying out the sputter-deposition of the NCT samples.

Mr Thomas Jervis of Los Alamos National Laboratory, USA for the laser processing.

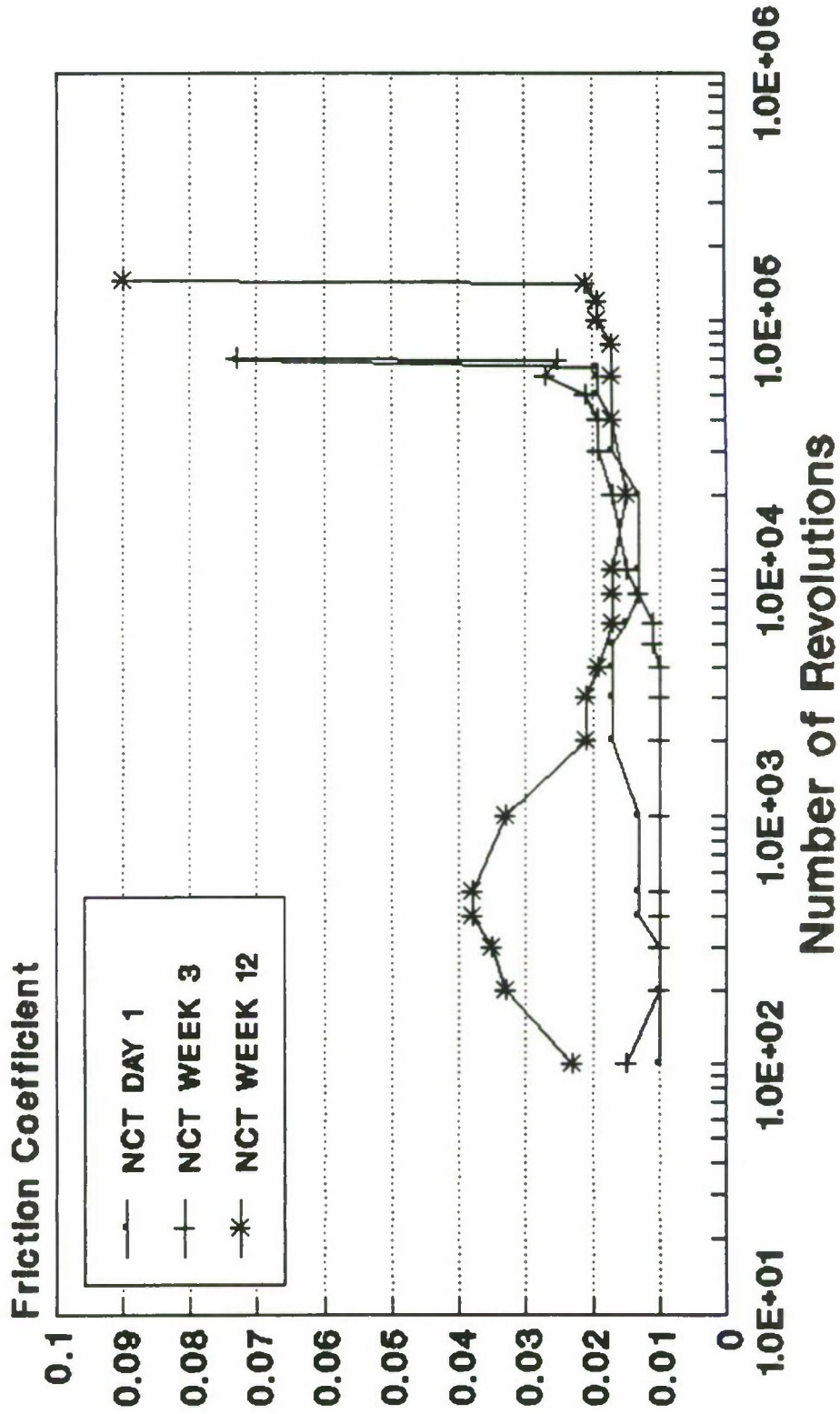
Dr Hamid Kheyrandish and Dr John Colligon at the University of Salford for the ion implantation work.



# NCT STORAGE STUDY RESULTS

## 80N LOAD, 400 RPM, $5 \times 10^{-7}$ TORR

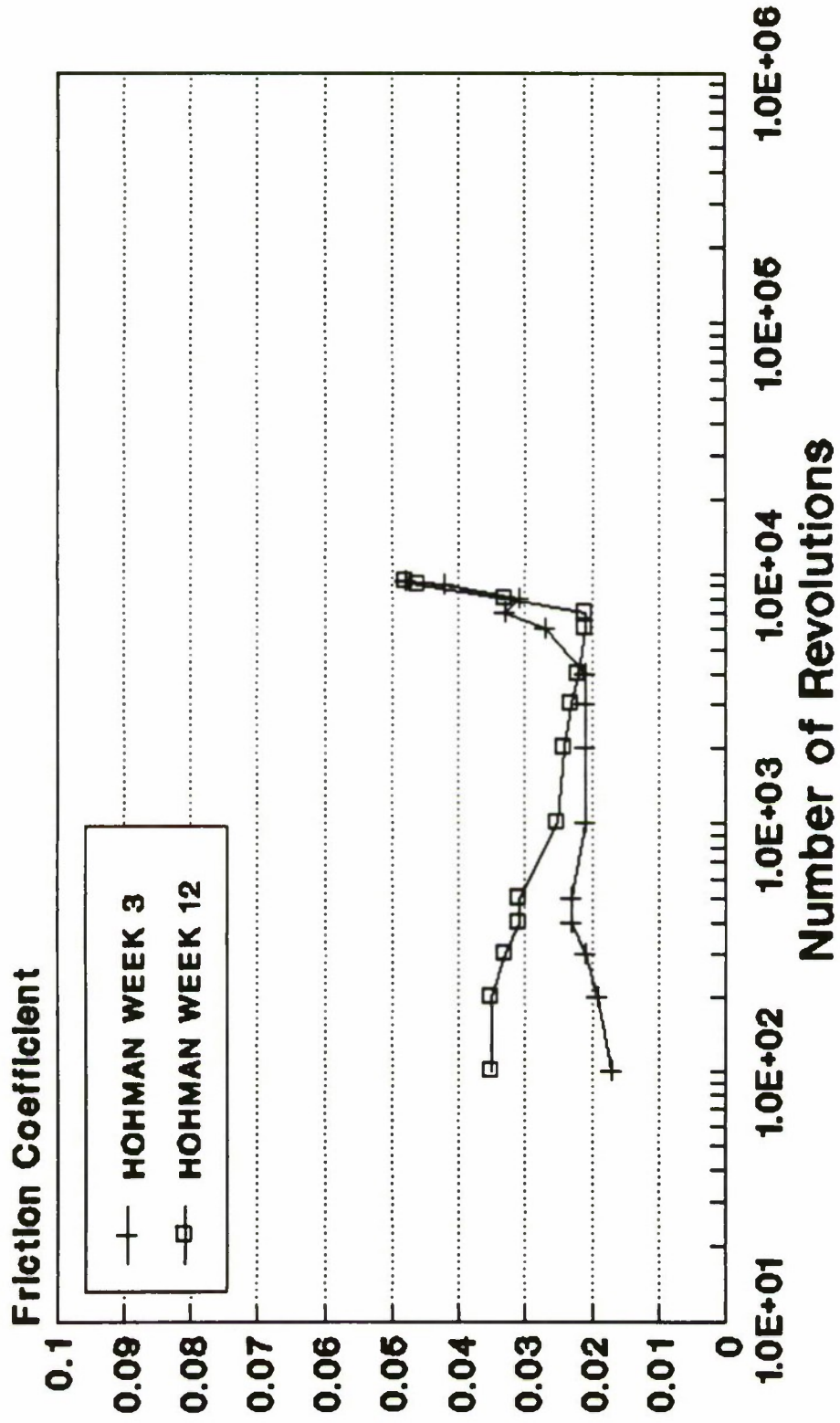
Figure 1.



# HOHMAN STORAGE STUDY RESULTS

## 80N LOAD, 400 RPM, $\leq 5E-7$ TORR

Figure 2.



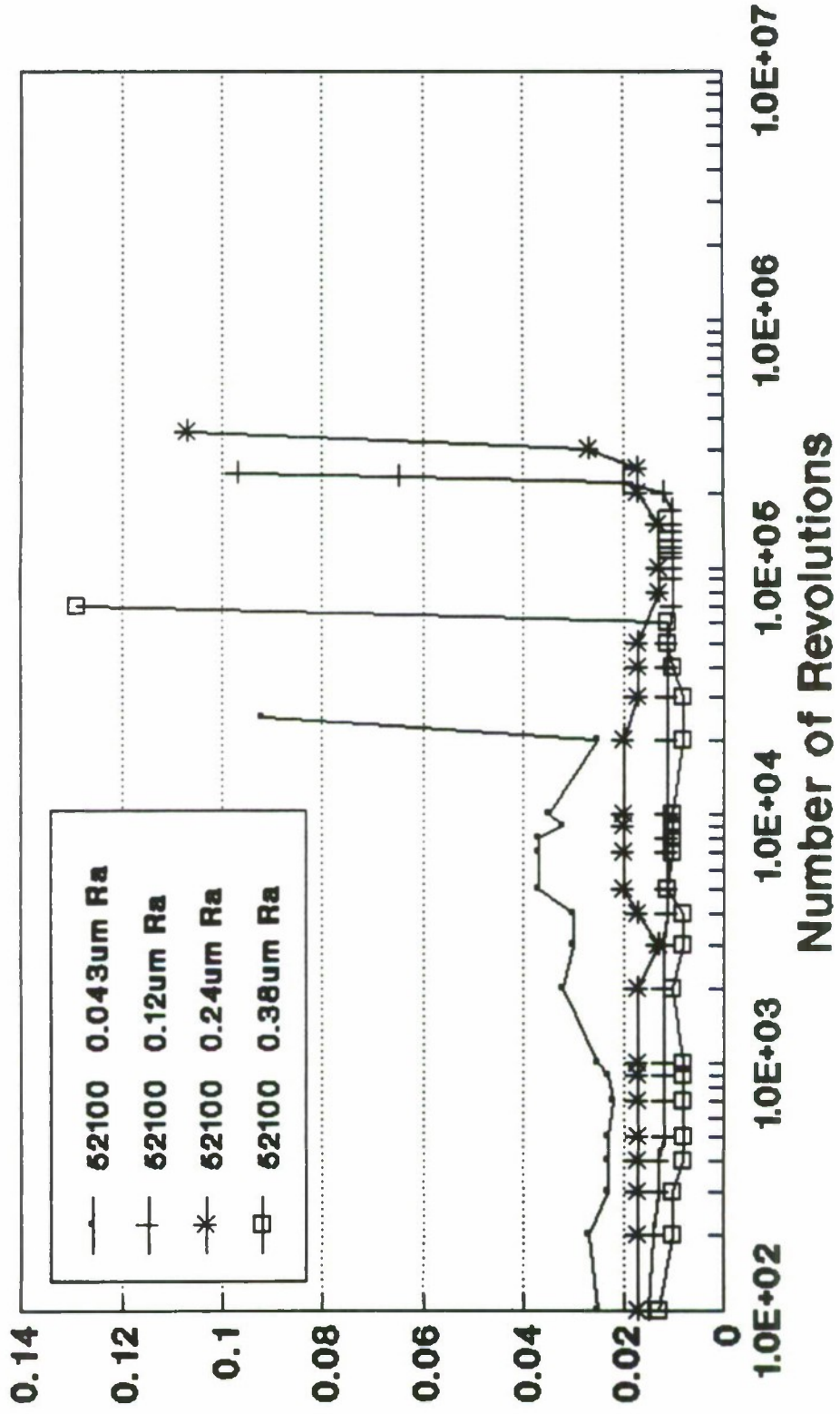


# SURFACE ROUGHNESS EVALUATION

## 50N LOAD, 400 RPM, $5E-7$ TORR

FRICTION  
COEFFICIENT

Figure 3.

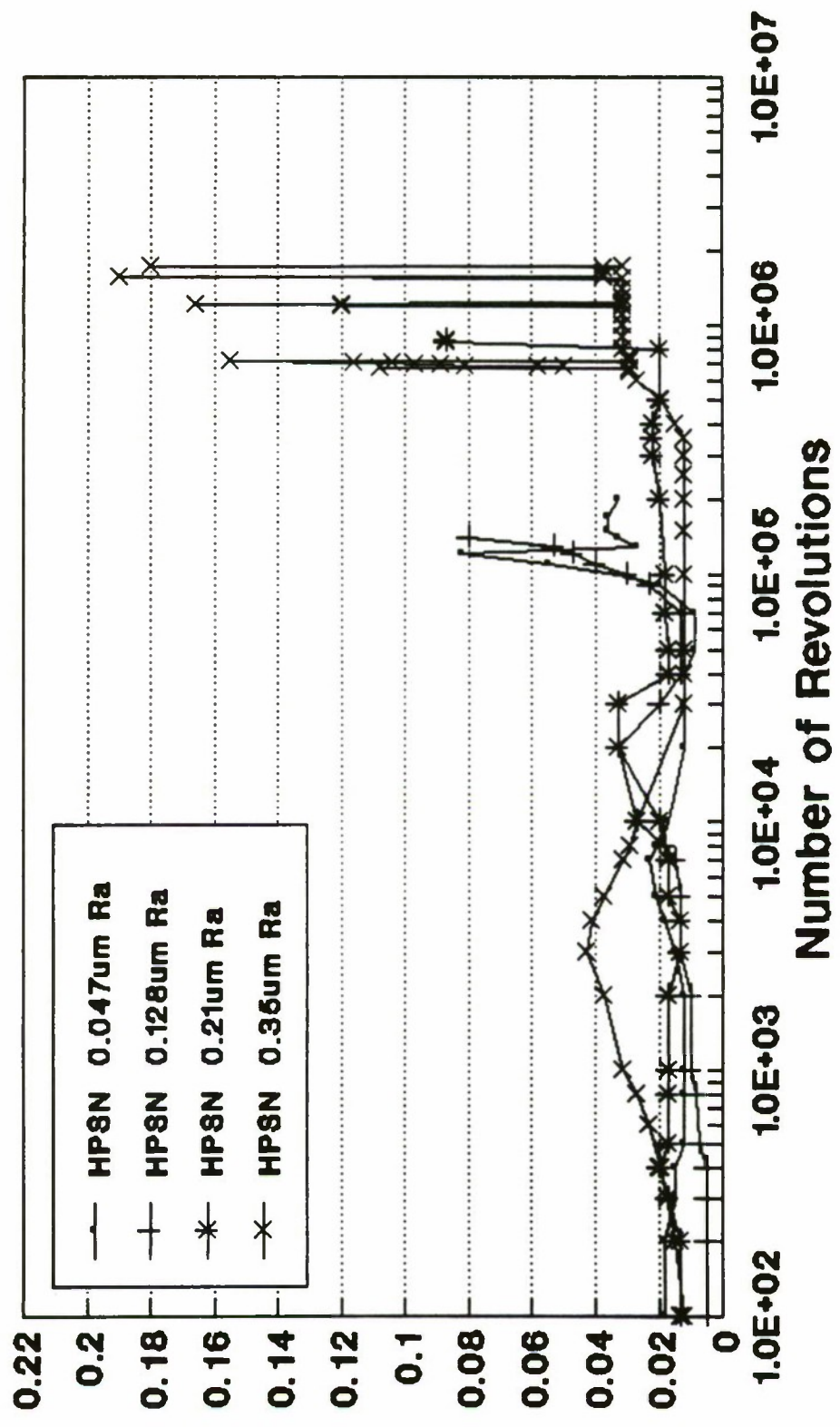


# SURFACE ROUGHNESS EVALUATION

## 50N LOAD, 400 RPM, $\times 5E-7$ TORR

Figure 4.

FRICTION  
COEFFICIENT



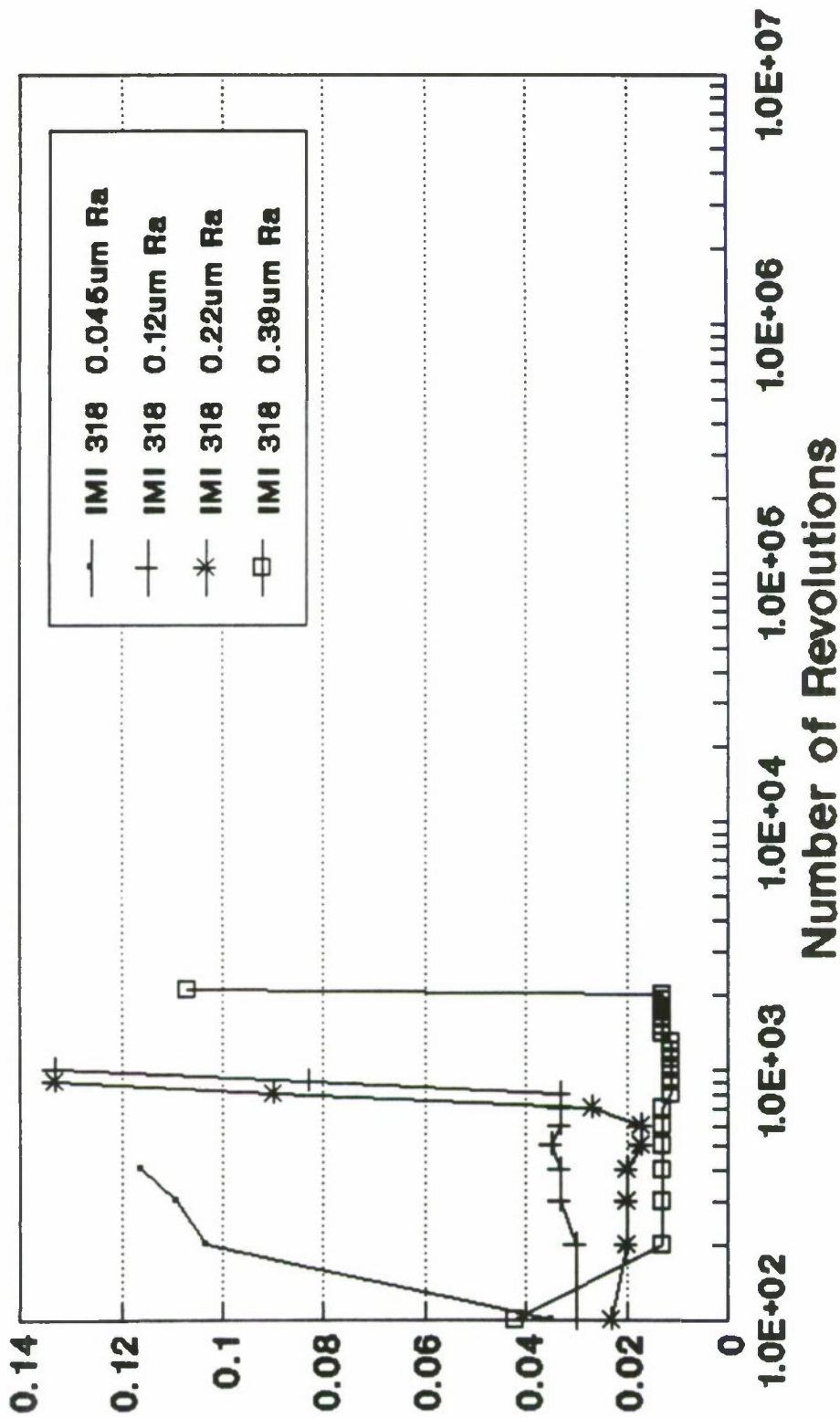


# SURFACE ROUGHNESS EVALUATION

## 50N LOAD, 400 RPM, $5E-7$ TORR

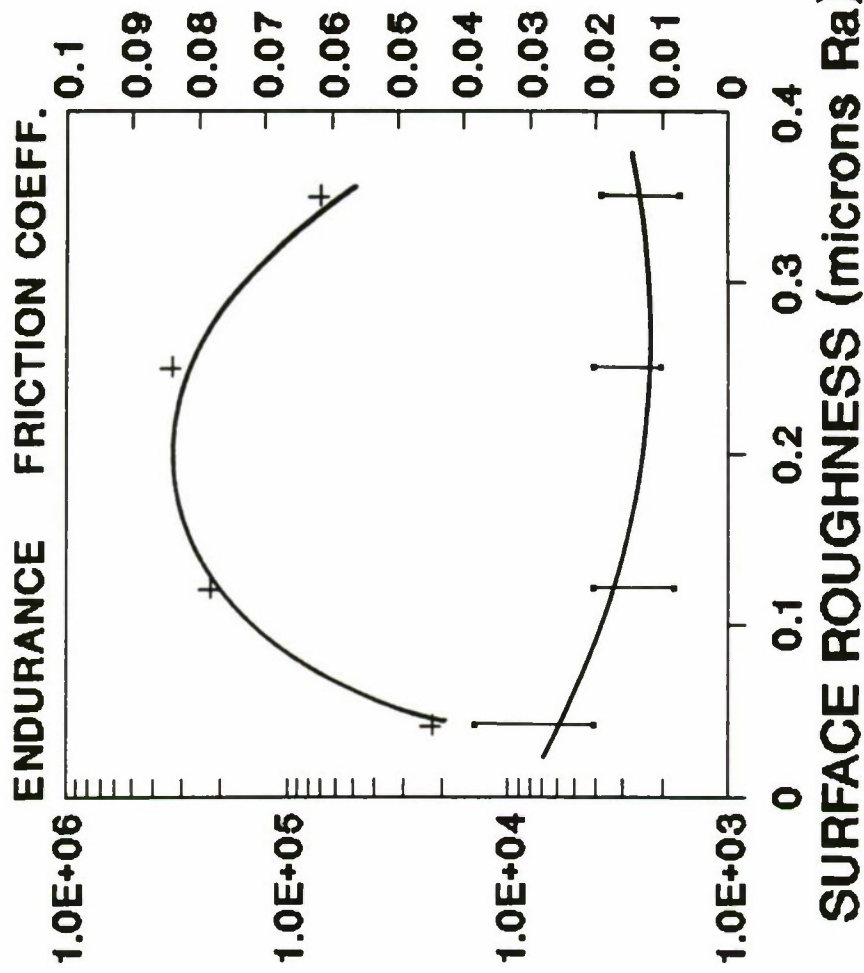
FRICION  
COEFFICIENT

Figure 5.



# THE EFFECT OF SURFACE ROUGHNESS ON FILM ENDURANCE AND FRICTION COEFFICIENT

50N LOAD, 400 RPM,  $5 \times 10^{-7}$  TORR



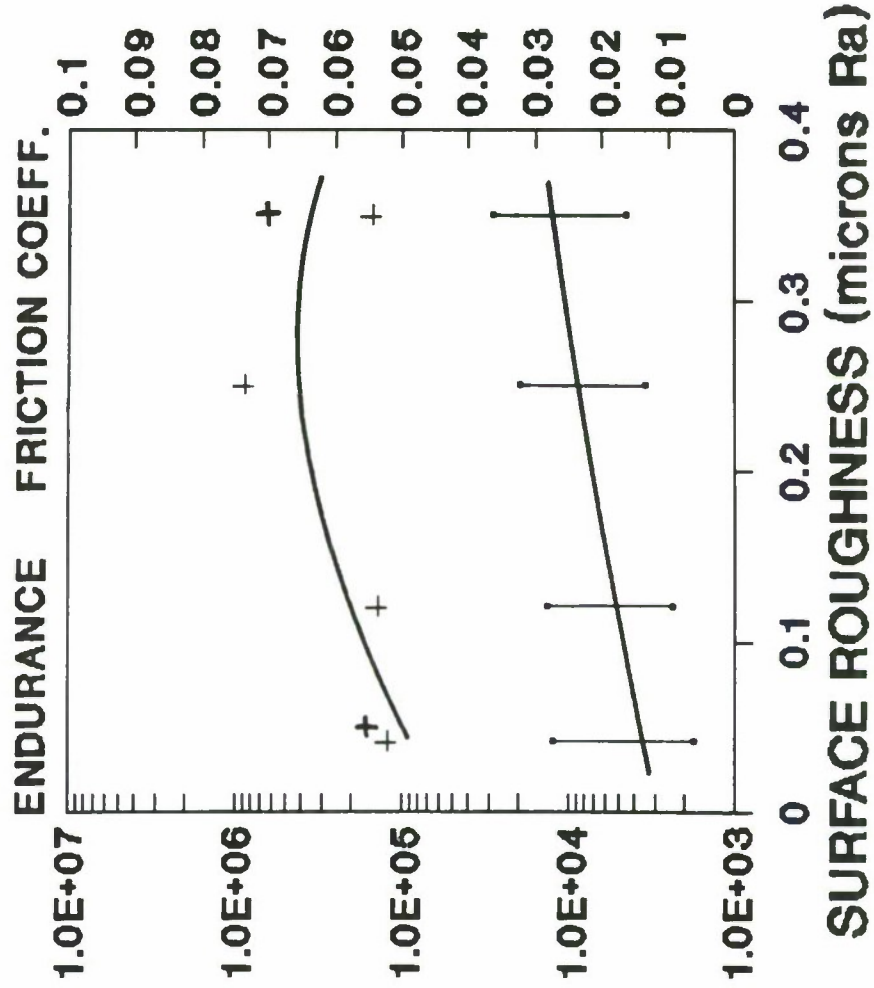
52100  
+ ENDURANCE  
· FRICTION

National Centre of Tribology

Figure 6.

# THE EFFECT OF SURFACE ROUGHNESS ON FILM ENDURANCE AND FRICTION COEFFICIENT

50N LOAD, 400 RPM,  $5E-7$  TORR



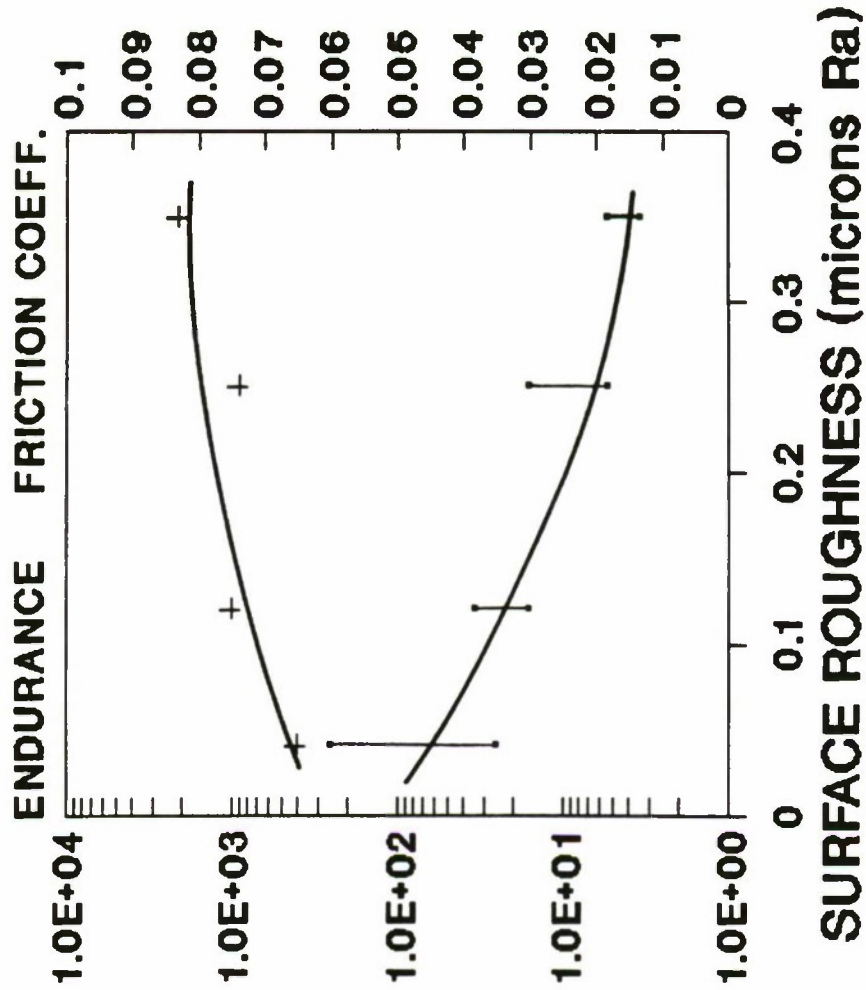
SI3N4  
+ ENDURANCE  
. FRICTION

National Centre of Tribology

Figure 7.



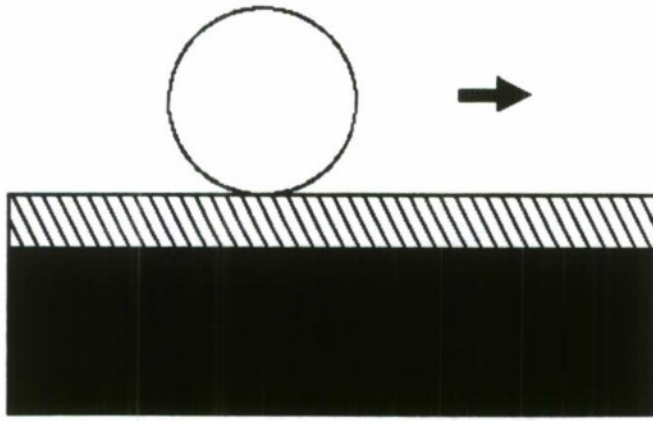
# THE EFFECT OF SURFACE ROUGHNESS ON FILM ENDURANCE AND FRICTION COEFFICIENT 50N LOAD, 400 RPM, $5 \times 10^{-7}$ TORR



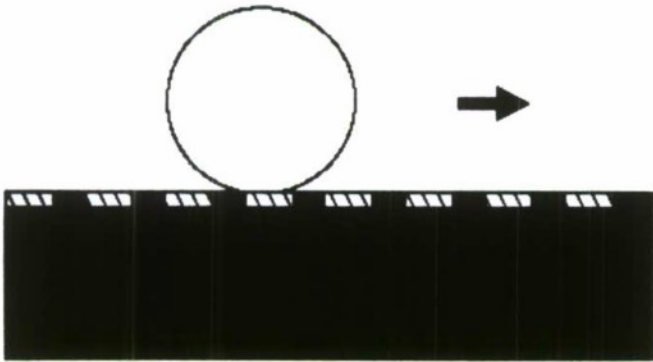
**TI ALLOY**  
**+ ENDURANCE**  
**. FRICTION**

National Centre of Tribology

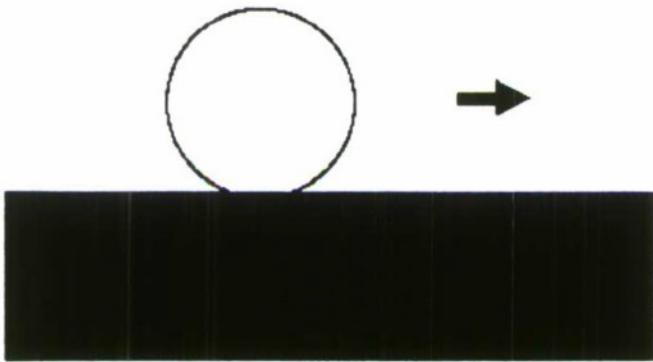
Figure 8.



(a) HPSN on MoS<sub>2</sub>



(b) HPSN on MoS<sub>2</sub> + HPSN

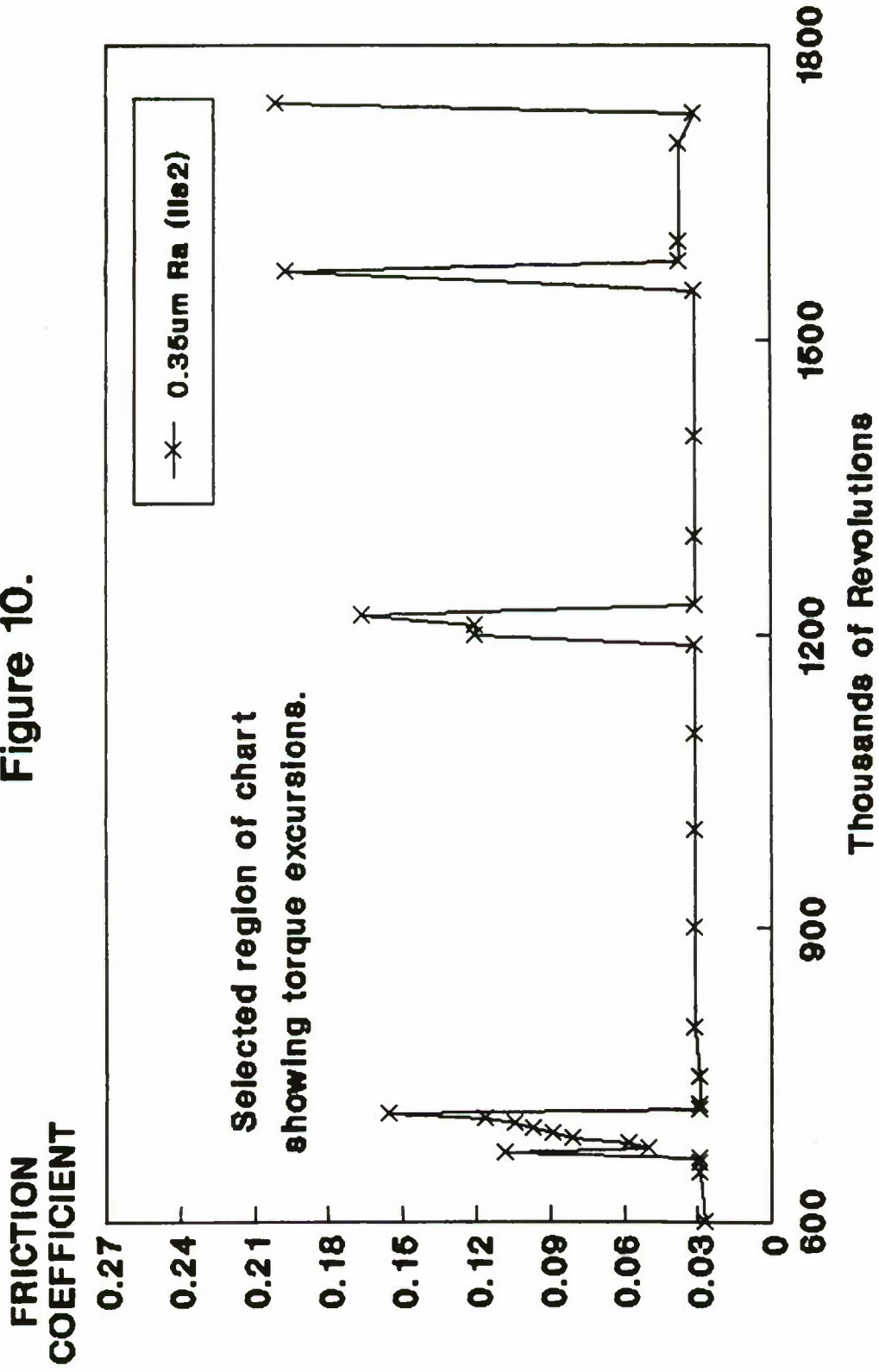


(c) HPSN on HPSN

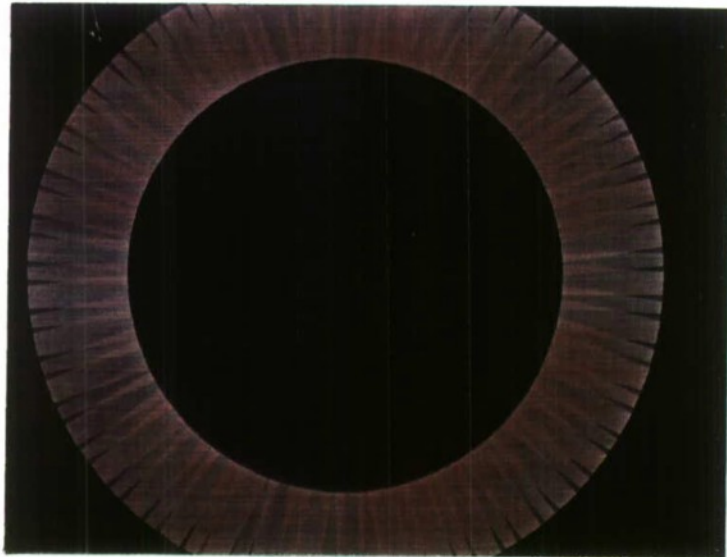
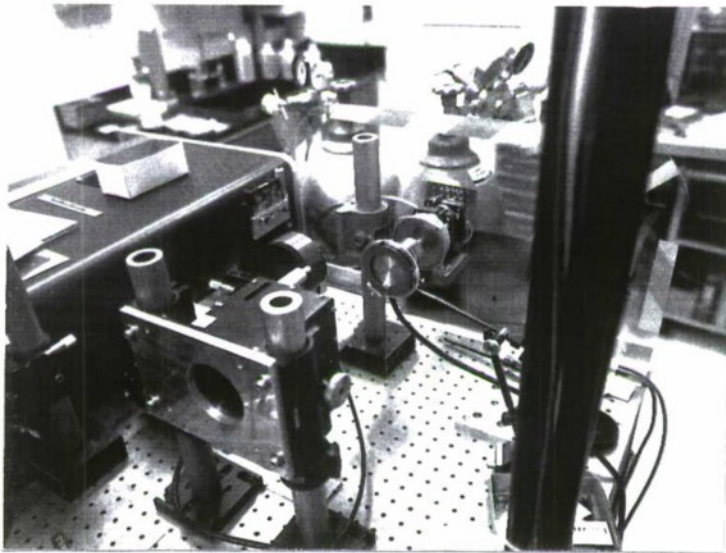
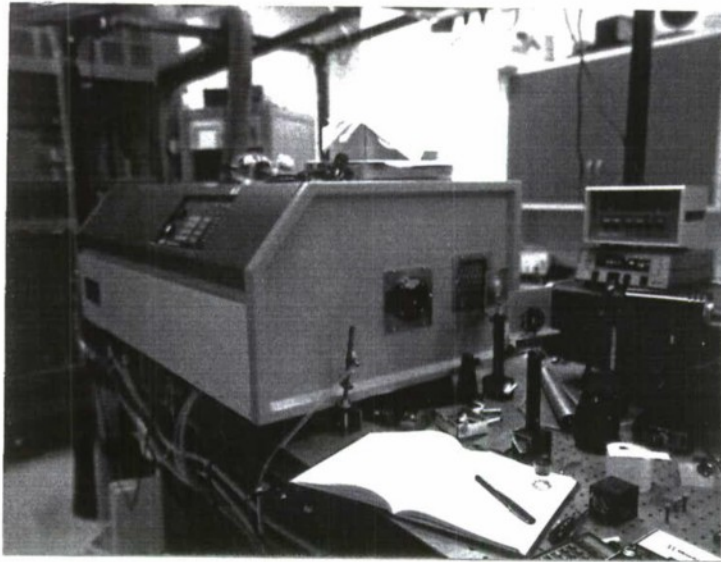
Figure 9.

# SURFACE ROUGHNESS EVALUATION HOT PRESSED SILICON NITRIDE

Figure 10.







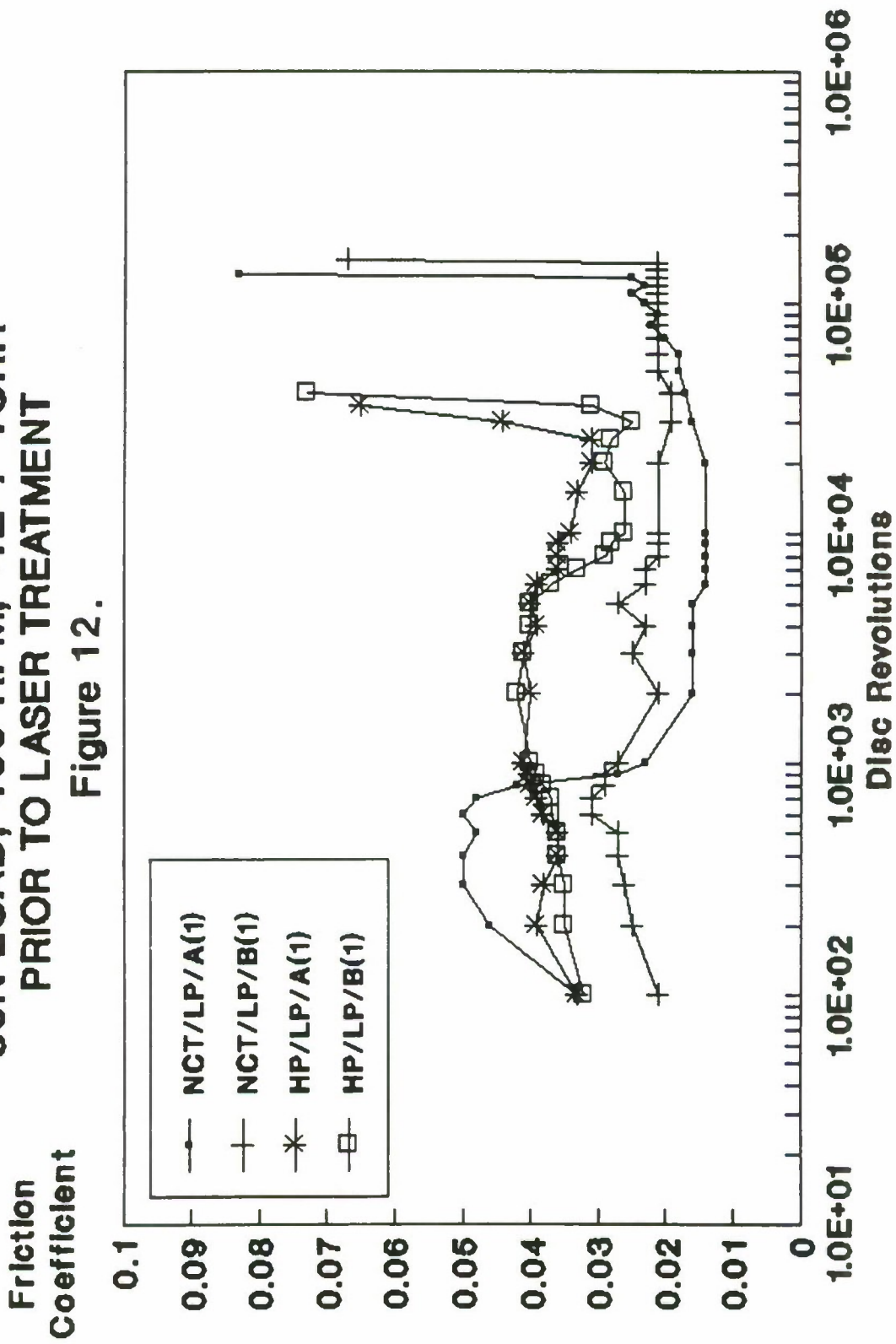
**Figure 11.**

# LASER TREATMENT STUDY

## 80N LOAD, 400 RPM, $4E-7$ TORR

### PRIOR TO LASER TREATMENT

Figure 12.

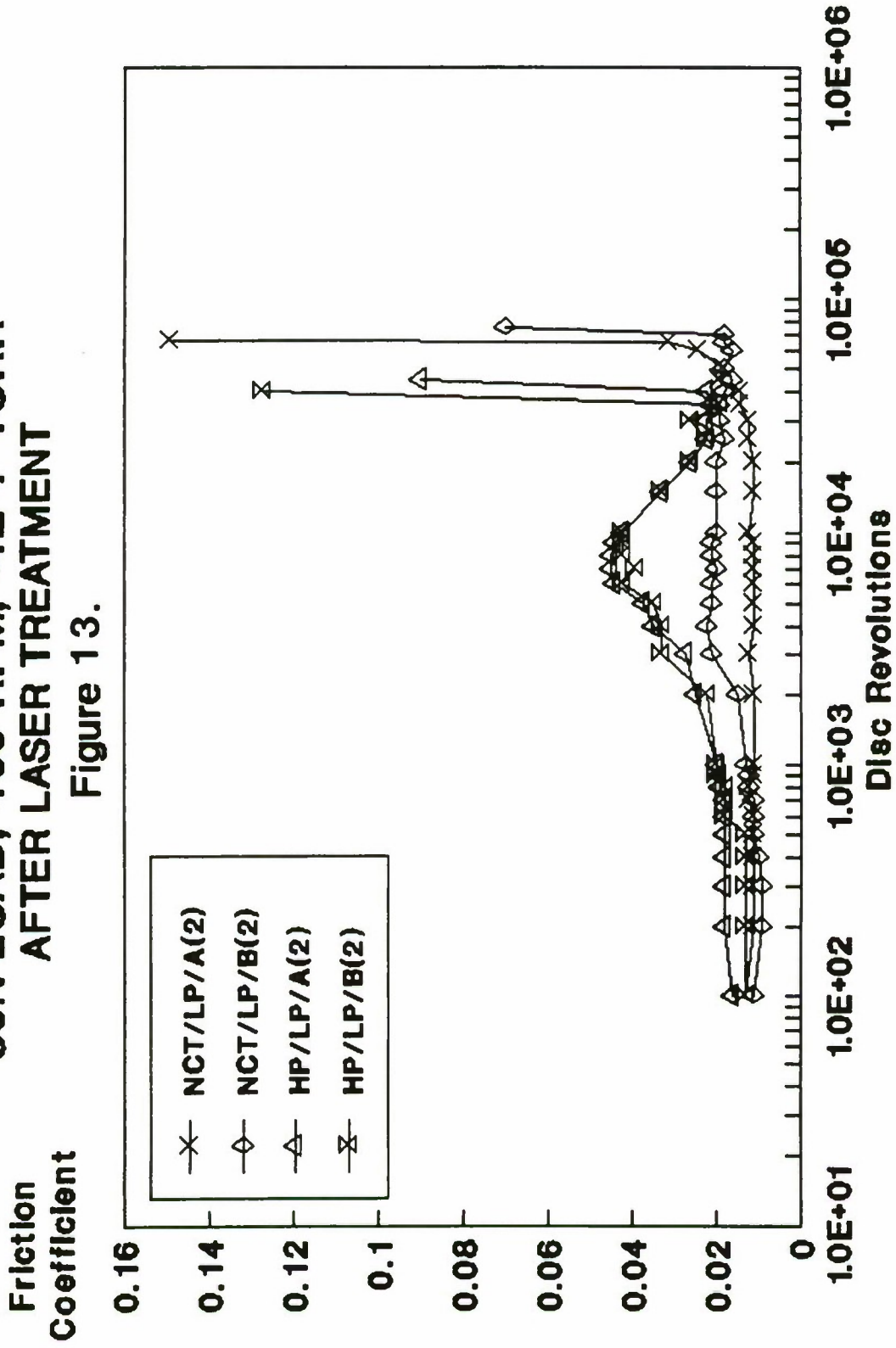


# LASER TREATMENT STUDY

## 80N LOAD, 400 RPM, $4E-7$ TORR

### AFTER LASER TREATMENT

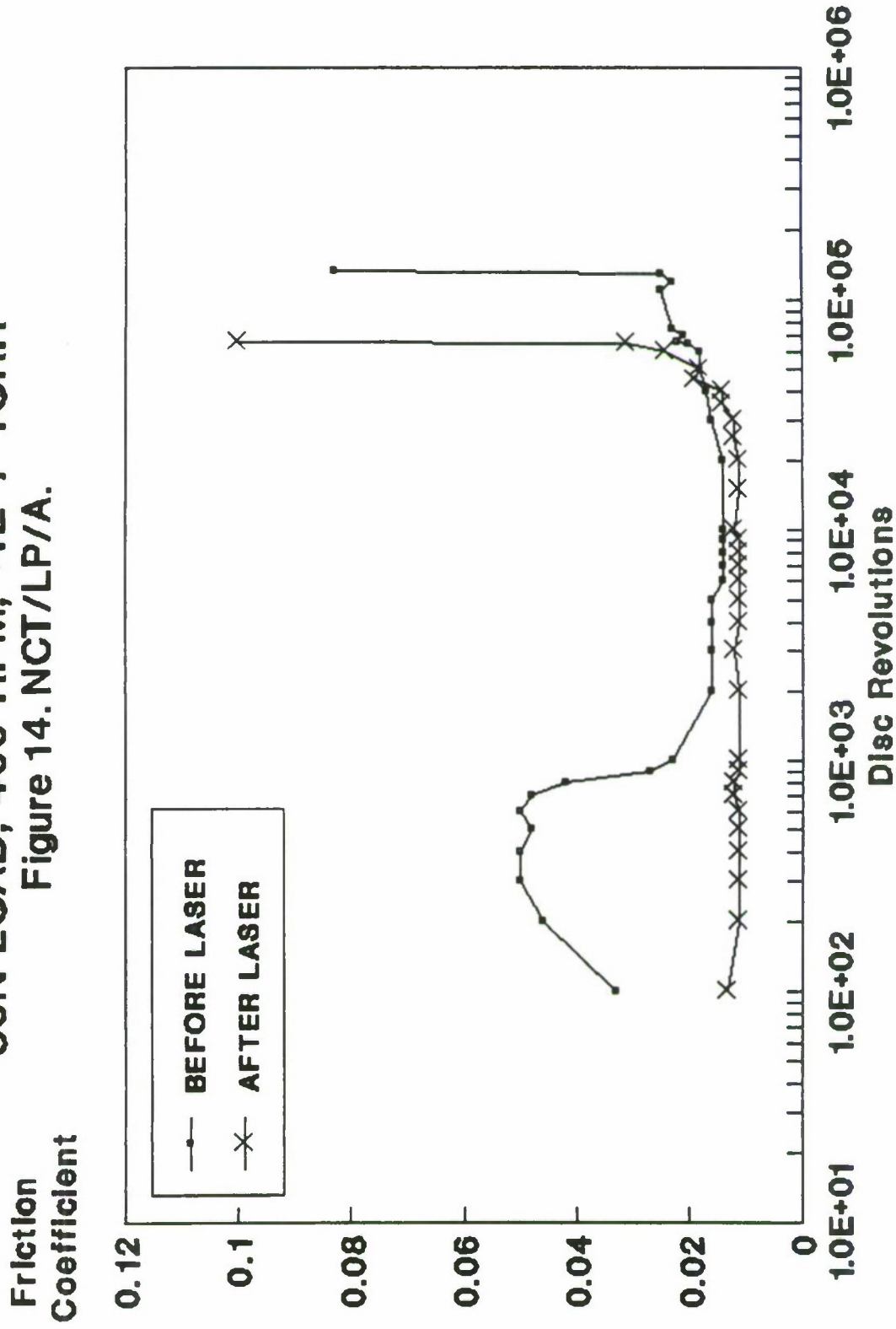
Figure 13.





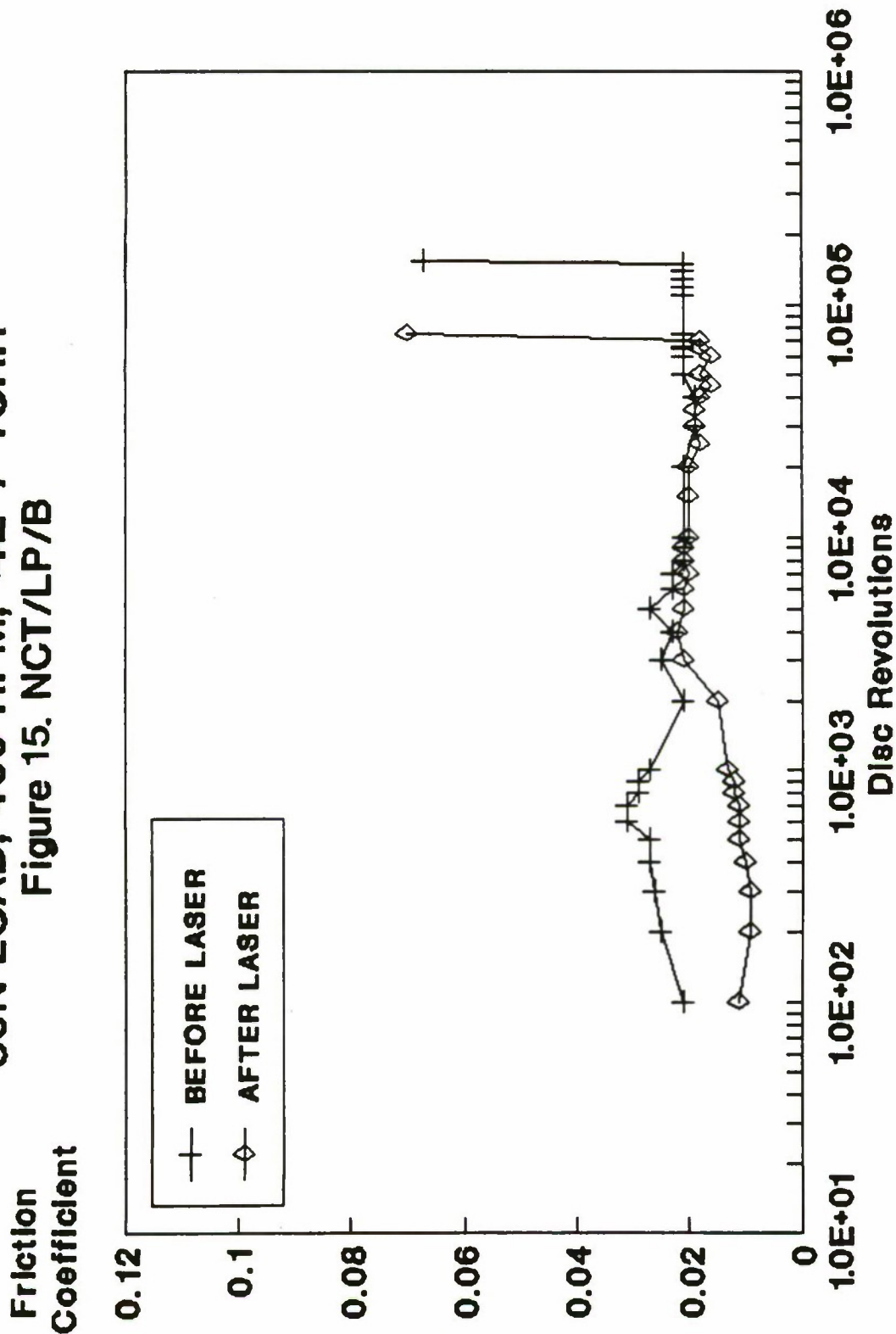
# LASER TREATMENT STUDY

80N LOAD, 400 RPM,  $<4E-7$  TORR  
Figure 14. NCT/LP/A.



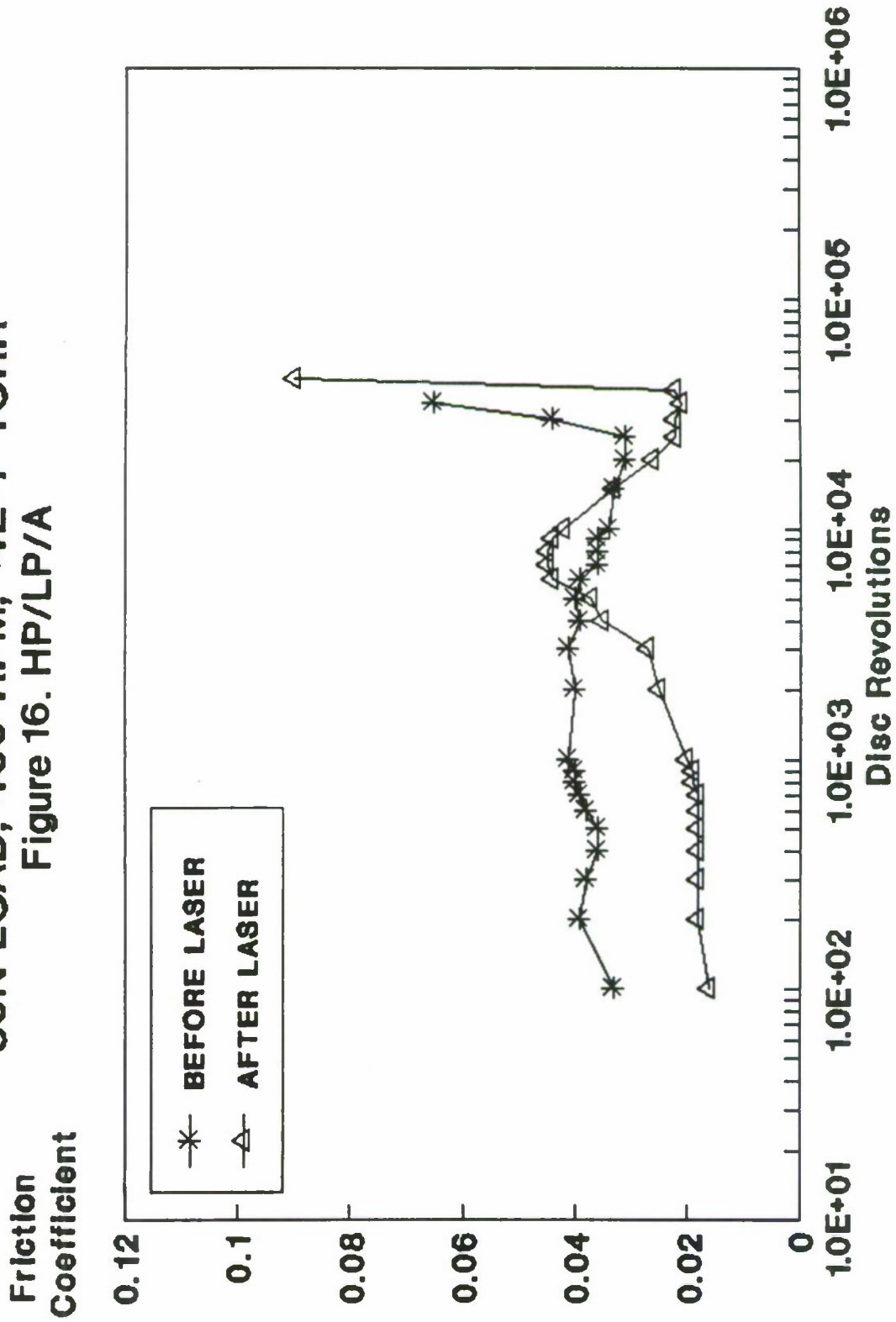
# LASER TREATMENT STUDY

80N LOAD, 400 RPM,  $4E-7$  TORR  
Figure 15. NCT/LP/B



# LASER TREATMENT STUDY

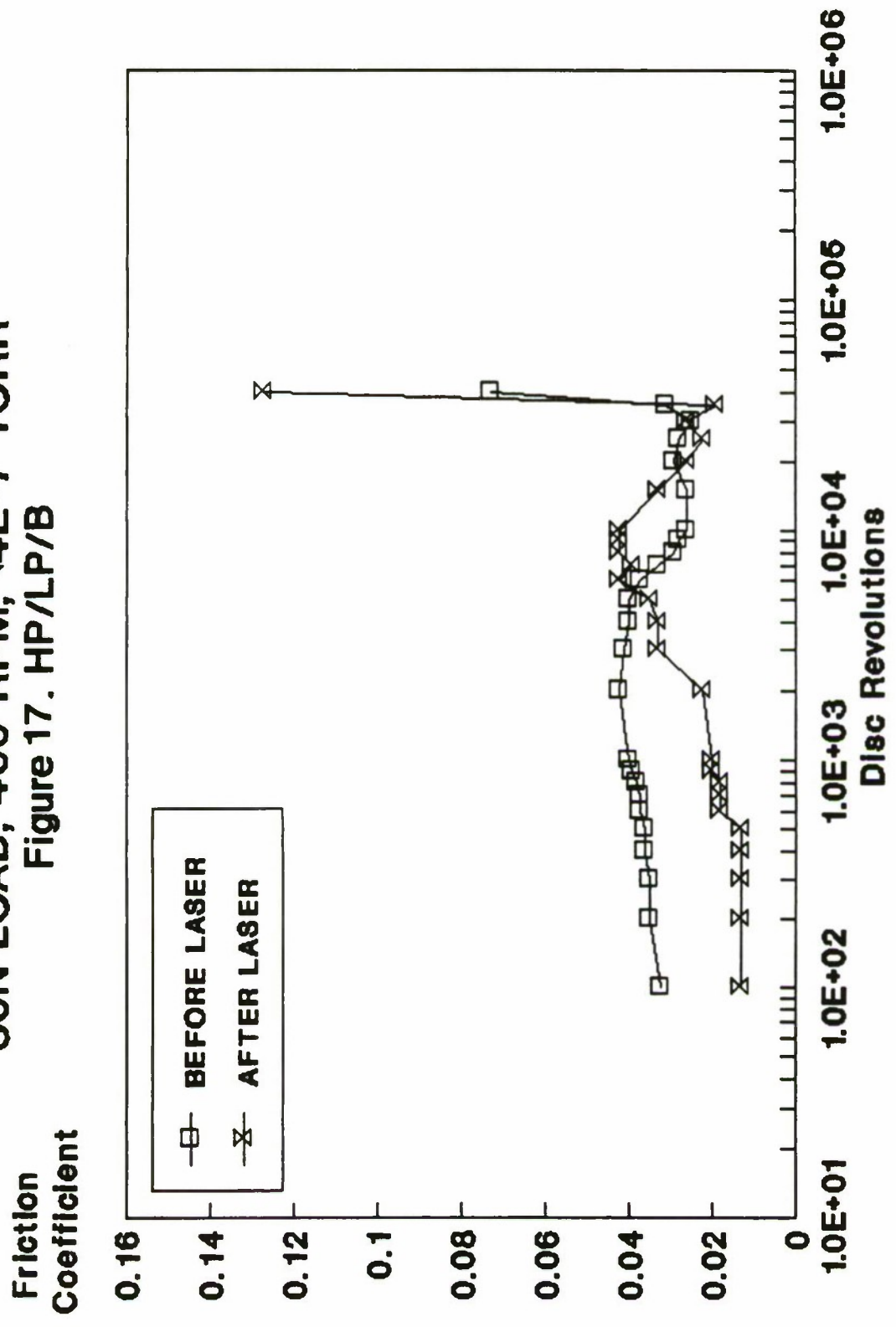
80N LOAD, 400 RPM,  $4E-7$  TORR  
Figure 16. HP/LP/A





# LASER TREATMENT STUDY

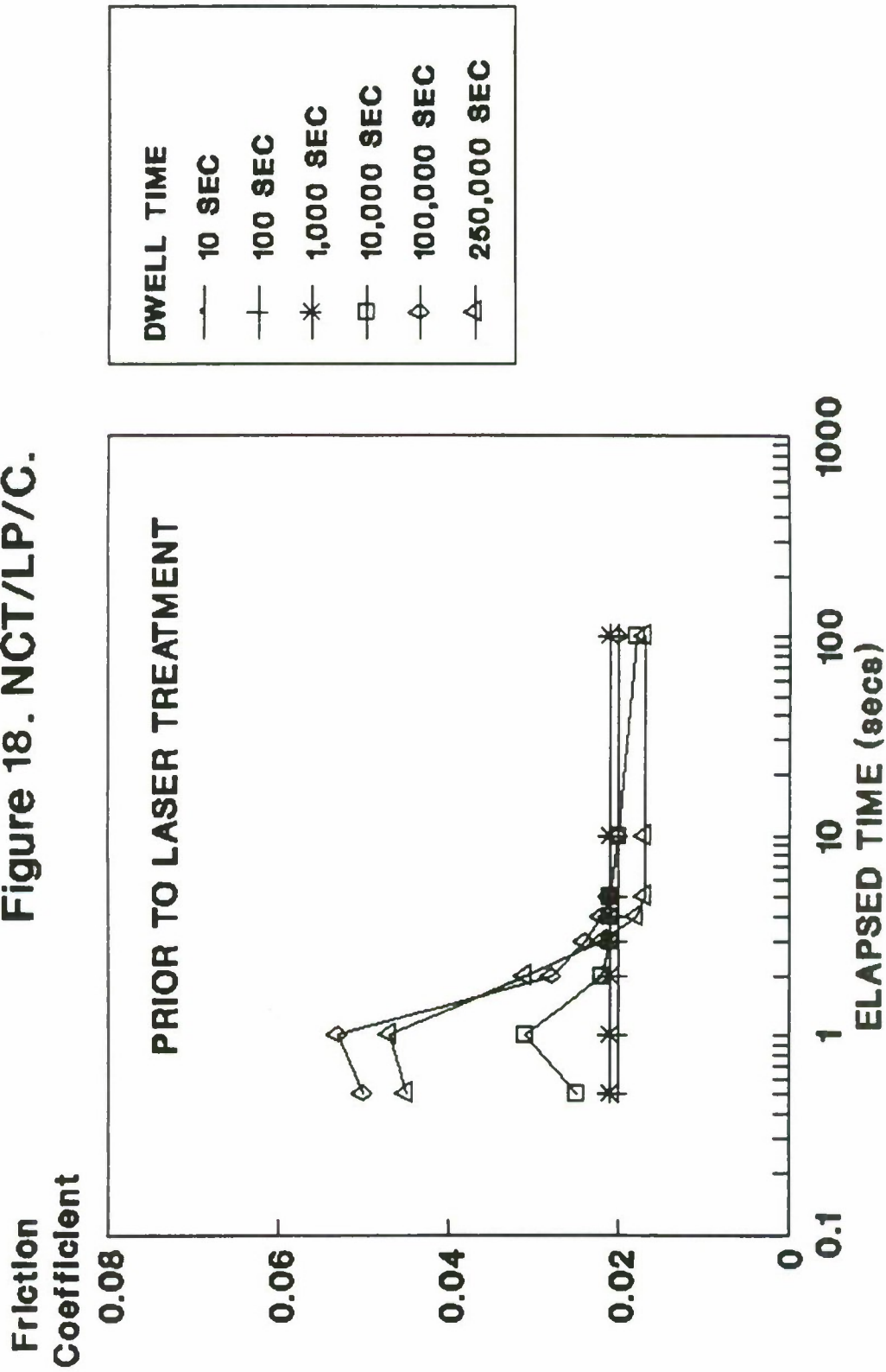
80N LOAD, 400 RPM,  $4E-7$  TORR  
Figure 17. HP/LP/B



# DWELL-TIME TEST

## 20N LOAD, 60 RPM, $4E-7$ TORR

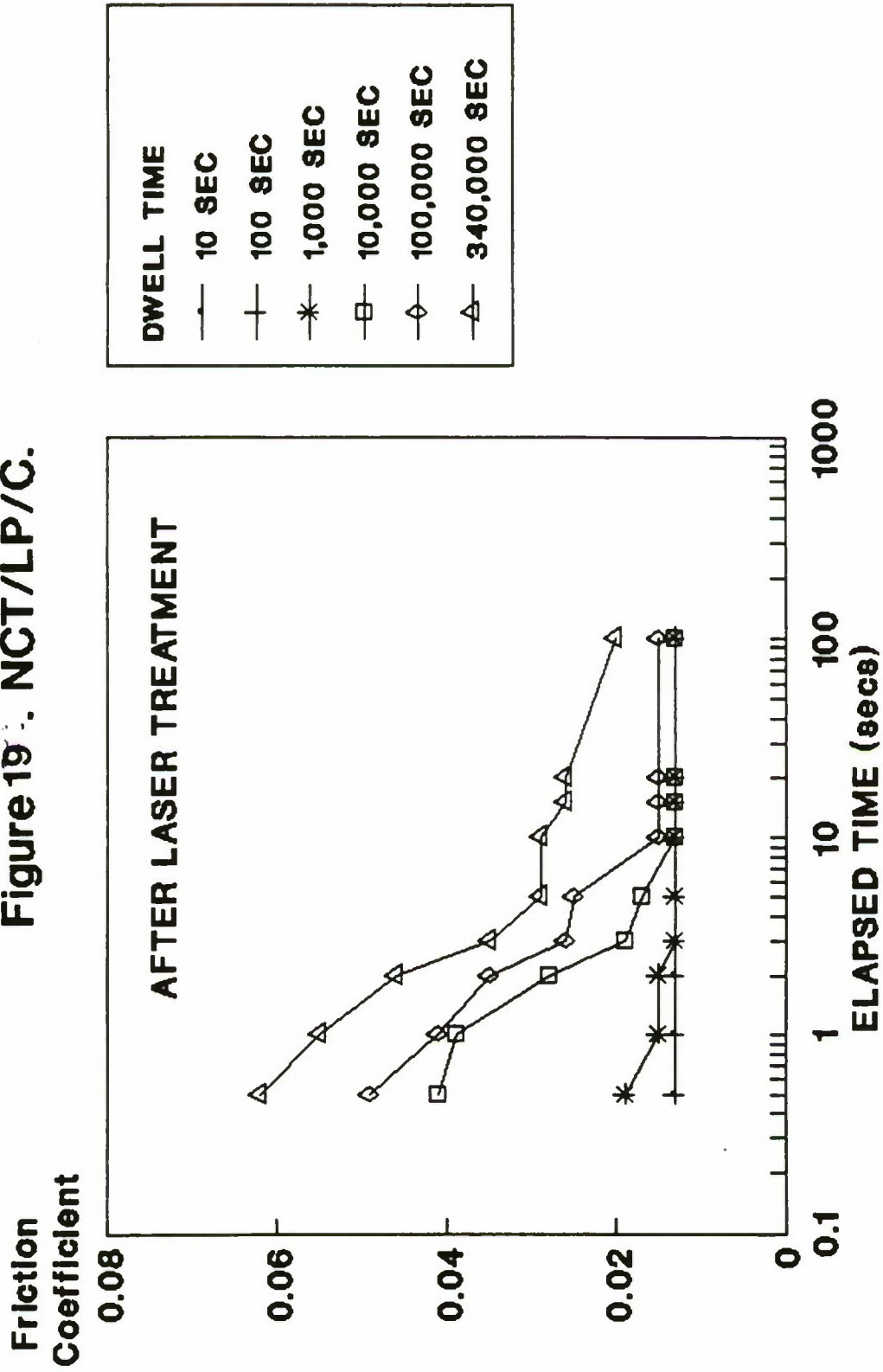
### Figure 18. NCT/LP/C.



# DWELL-TIME TEST

## 20N LOAD, 60 RPM, $4 \times 10^{-7}$ TORR

### Figure 19: NCT/LP/C.

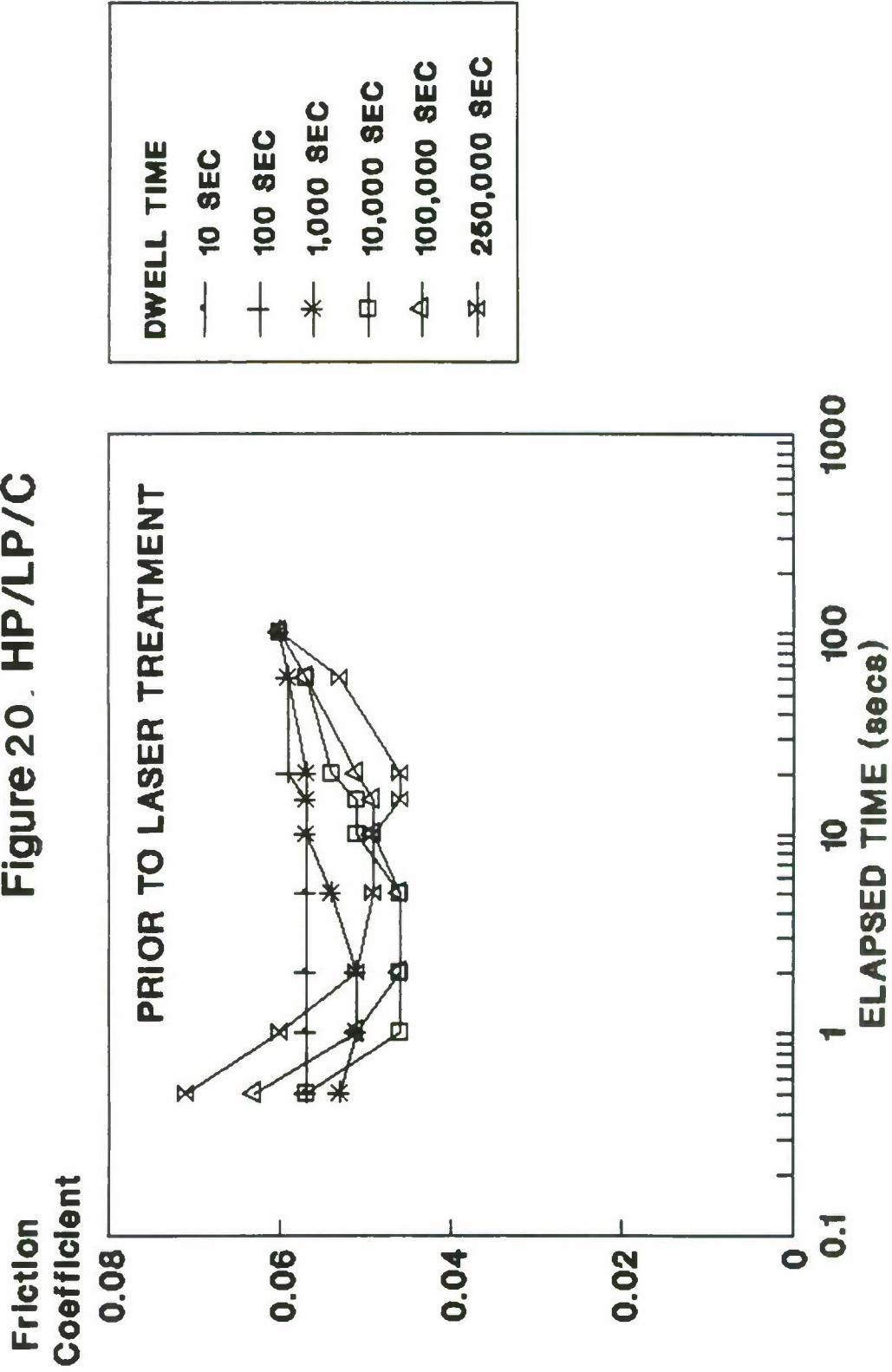




# DWELL-TIME TEST

## 20N LOAD, 60 RPM, $4E-7$ TORR

### Figure 20. HP/LP/C



# DWELL-TIME TEST

## 20N LOAD, 60 RPM, $4E-7$ TORR

### Figure 21. HP/LP/C(2)

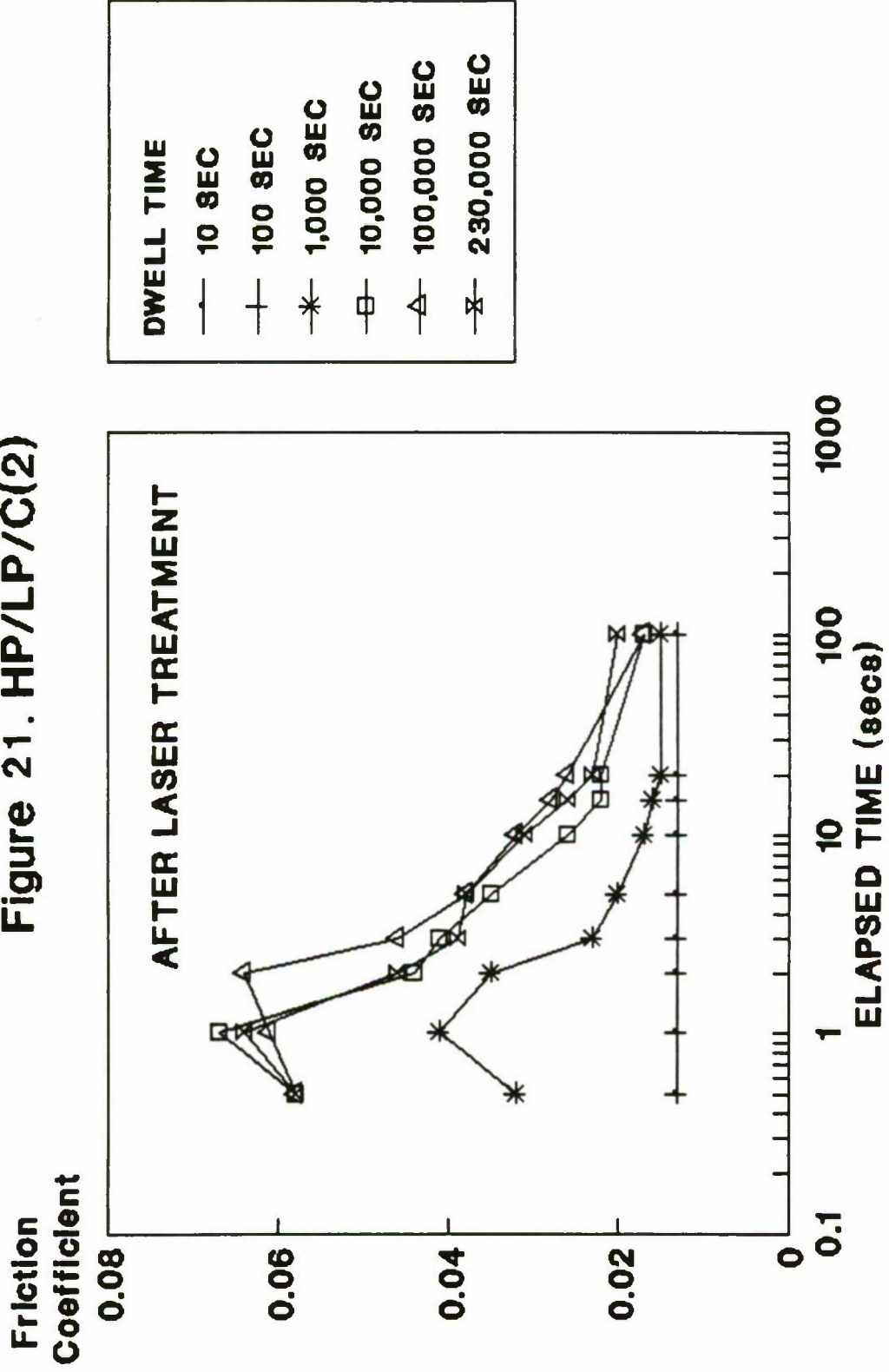
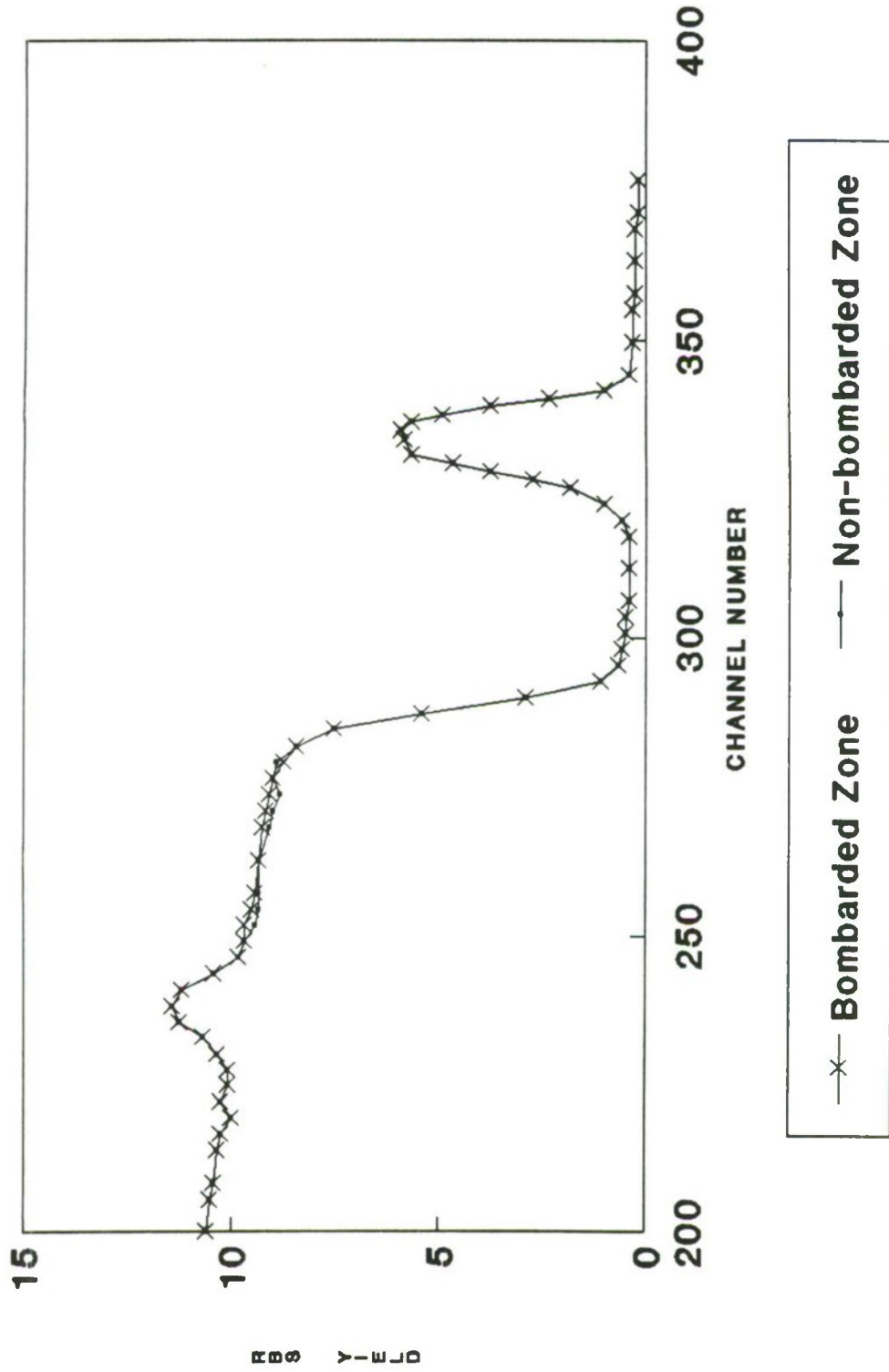
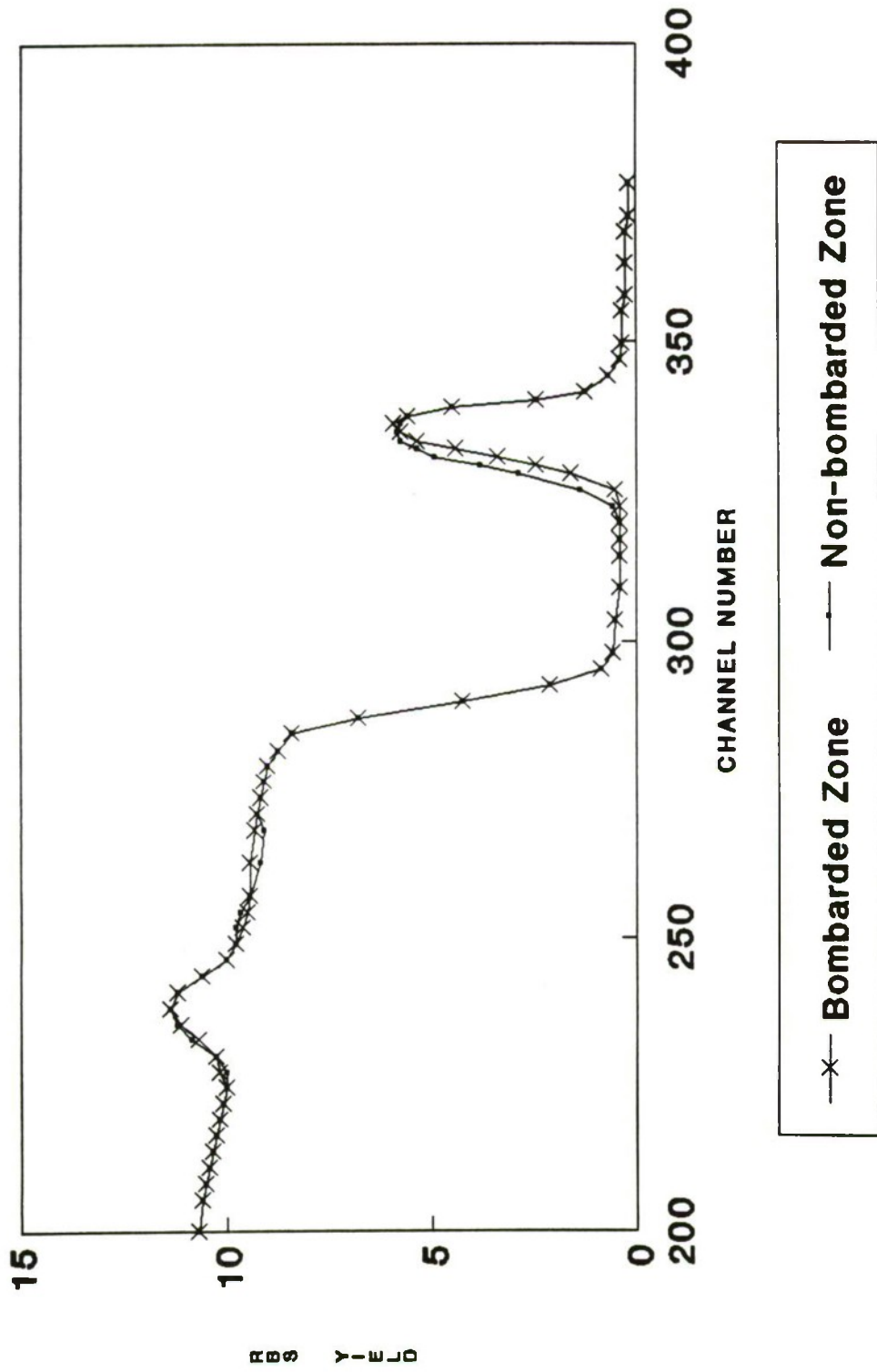


Fig. 22(a) R.B.S. SPECTRUM  
 MoS2 on steel  
 After Ion Beam Bombardment



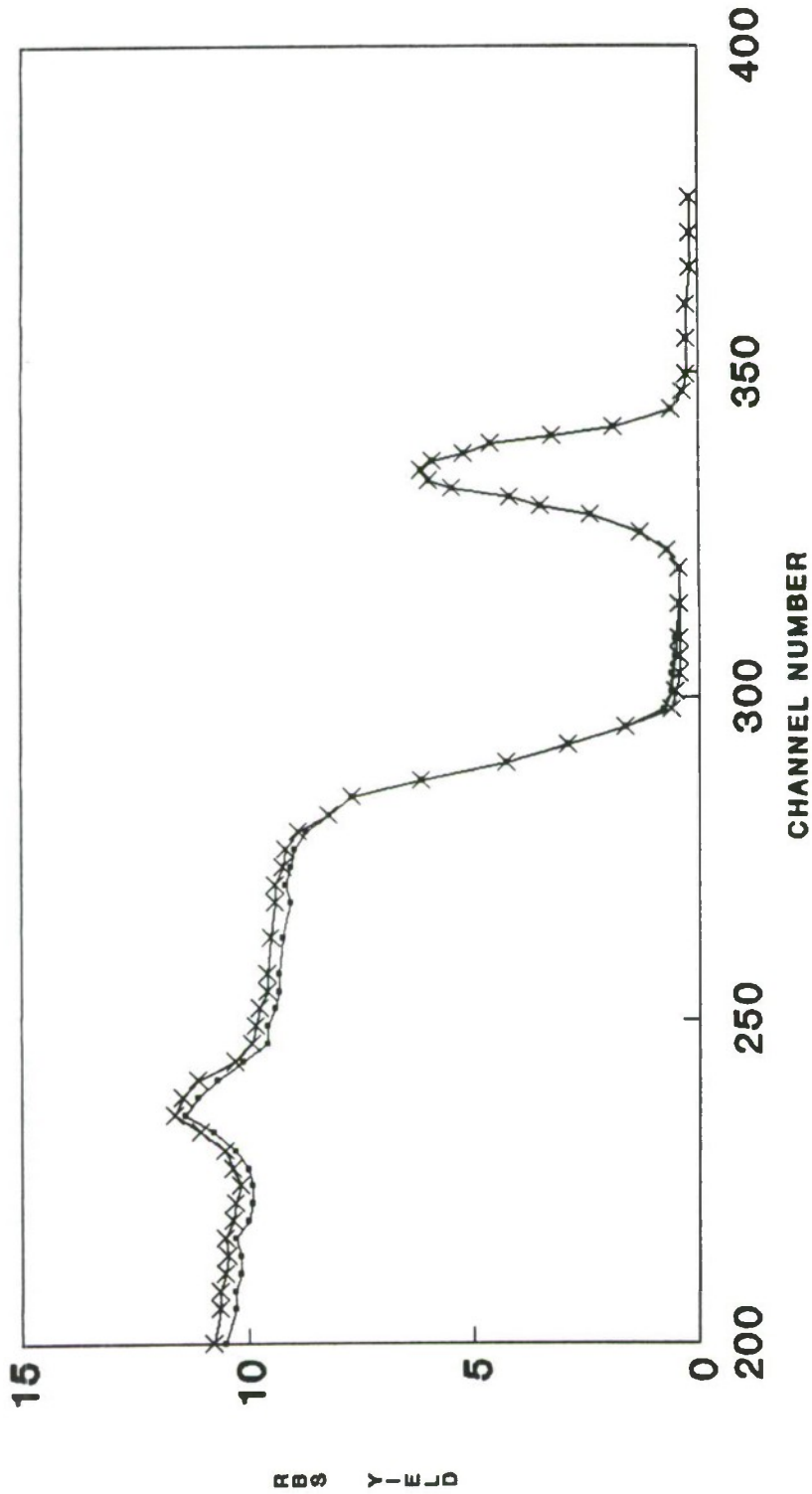


**Fig. 22(b) R.B.S. SPECTRUM  
MoS2 on Steel  
After Ion Beam Bombardment**



Dose 3E16 ions/sq.cm.  
Nitrogen ions

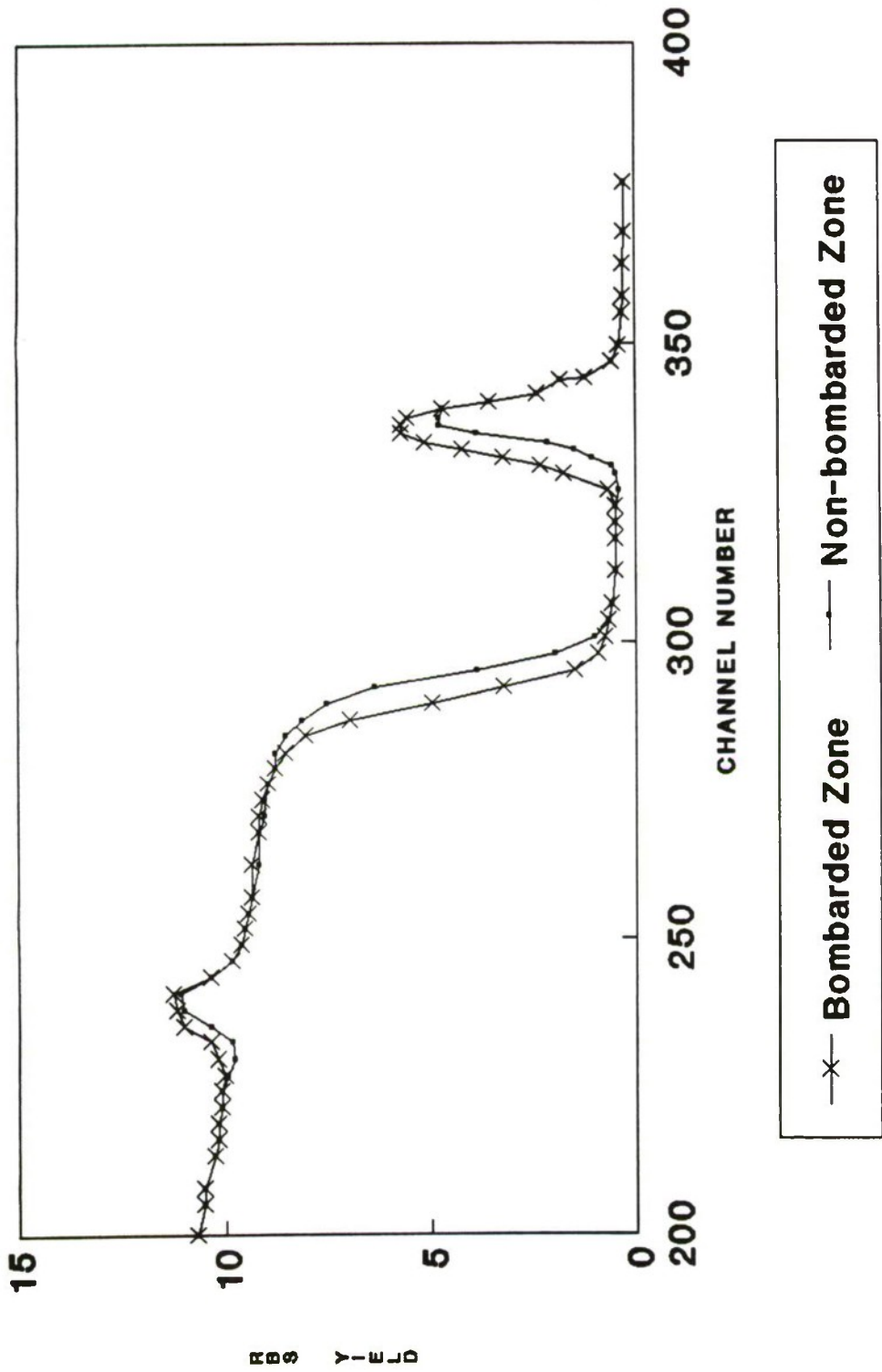
**Fig. 22(c) R.B.S. SPECTRUM  
MoS2 on Steel  
After Ion Beam Bombardment**



**—x— Bombarded Zone    — Non-bombarded Zone**

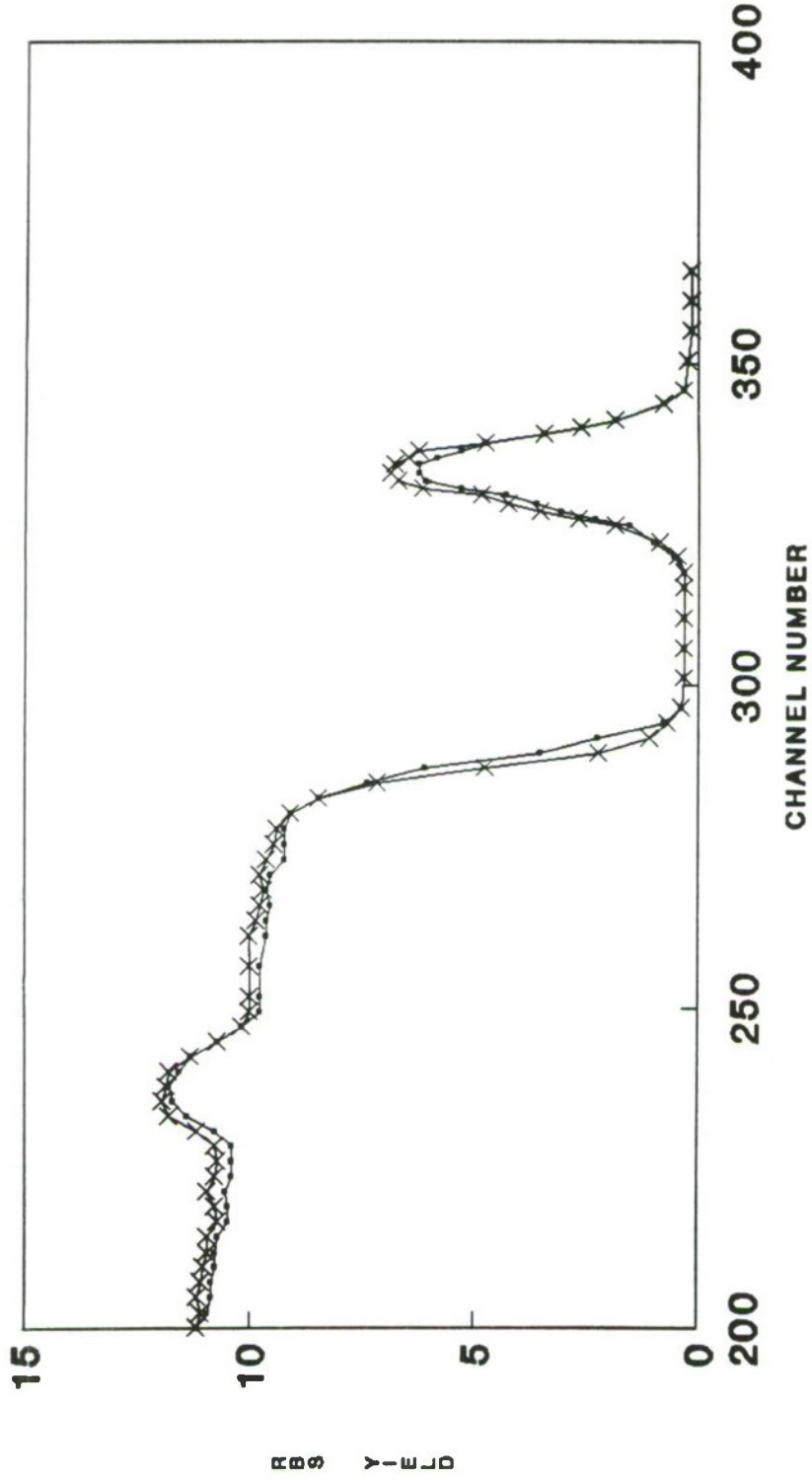
Dose  $6E16$  ions/sq.cm.  
Nitrogen ions

Fig. 22(d) R.B.S. SPECTRUM  
MoS2 on steel  
After Ion Beam Bombardment





**Fig. 22(e) R.B.S. SPECTRUM  
MoS2 on Steel  
After Ion Beam Bombardment**



**—x— Bombarded Zone    —•— Non-bombarded Zone**

**Dose 2E16 ions/sq.cm.  
Nitrogen ions**

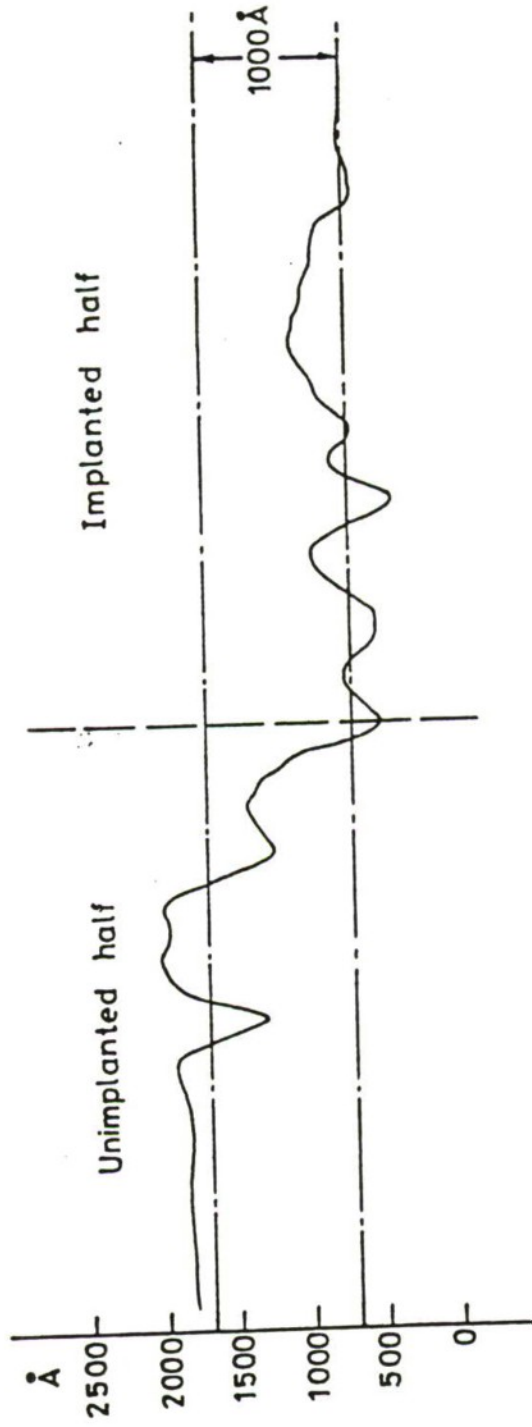
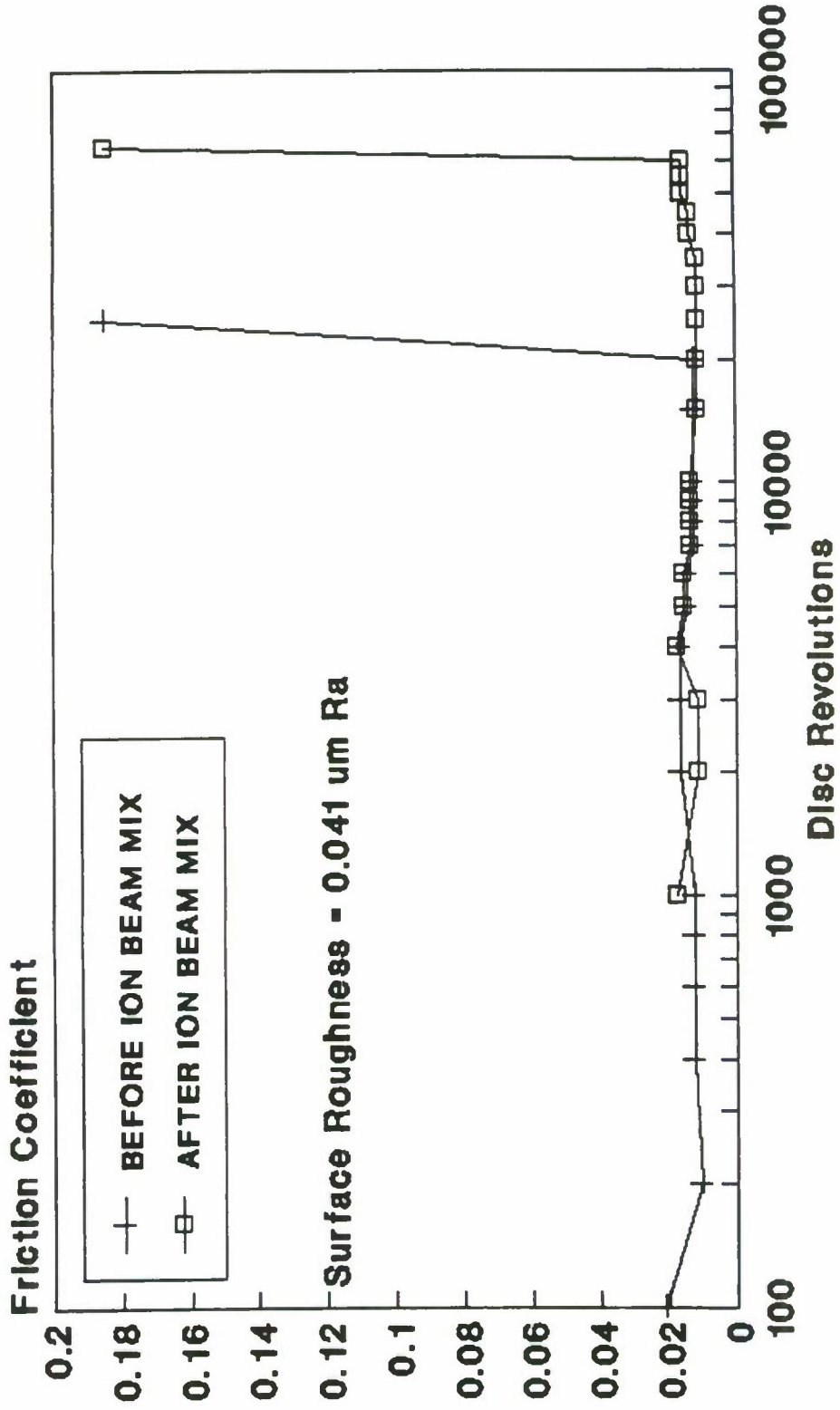


Figure 23 . Talystep profile across sample implanted by  $2 \times 10^{16}$  ions/cm<sup>2</sup>  
 LHS; unimplanted, RHS; implanted.

# ION BEAM MIXING STUDY

## 50N LOAD, 400 RPM, $5E-7$ TORR

Figure 24.





Appendix 1 Professional personnel associated with project.

Project Manager:

Dr W H Roberts, BSc, PhD, C Phys, F Inst P.  
Manager, NCT.

Senior Researchers:

Dr E W Roberts, BSc, PhD, C Phys, M Inst P.  
Professional & Management Grade 1.

Dr R A Rowntree, BSc, PhD, A I Mech E.  
Professional & Management Grade 1.

Researchers:

Dr W B Price, BSc, PhD.  
Professional & Management Grade 3.

B J Williams, BSc.  
Professional & Management Grade 4.

## Appendix 2. Meetings Attended.

June 3, 1987

B McConnell (USAF) and M Gardos (Hughes Aircraft) visited NCT for preliminary discussions on NCT programme.

August 13, 1987

Ken Carnahan of Carnahan Associates visited NCT to review progress.

September 7-10, 1987

W H Roberts, E W Roberts and R A Rowntree attended a SCORE meeting in Dayton, Ohio at which W H Roberts gave a presentation.

September 11-14, 1987

E W Roberts and R A Rowntree gave presentations on space tribology at NRL, Washington and Army Materials Lab., Boston.

September 25, 1987

Irwin Singer of NRL, Washington visited NCT for discussions.

October 8, 1987

Tom Stewart of Aerospace Corp., visited NCT for discussions.

January 11, 1988

D Carre, Aerospace Corp. visited NCT for discussions on space tribology.

April 11-15, 1988

W H Roberts, E W Roberts and R A Rowntree attended a SCORE meeting in Northumberland House, London. A presentation was made by W H Roberts.

April 18-19, 1988

A TIWG meeting was held at NCT. Those present were: B McConnell, L Fehrenbacher, P Fleischauer, B Stupp and L Pope in addition to NCT representatives.

April 20, 1988

E W Roberts along with TIWG members visited Plessey Research Centre, Caswell for discussions on diamond films.

June 6 -10, 1988

E W Roberts and R A Rowntree attended an Air Force Technical Review meeting at which E W Roberts gave a presentation on NCT's experience with sputtered MoS<sub>2</sub>. TIWG meetings were also attended at the same venue.

August 22-30, 1988

E W Roberts and R A Rowntree gave presentations on space tribology at the following establishments:

Martin Marietta, Denver

Lockheed, San Fransisco  
Hughes Aircraft Co., L.A  
Rockwell, L.A

Discussions were later held at Technology Assessment and Transfer Inc., Annapolis.

October 17-21, 1988

R A Rowntree gave a presentation entitled "A review of trends in European Space Mechanisms Design" at a SCORE meeting held in Huntsville.

November 28 - December 2, 1988

E W Roberts and M J Todd presented invited papers (respectively, "The in-vacuo, tribological properties of high-rate MoS<sub>2</sub> applied to metal and ceramic substrates" and "A review of European trends in space tribology and its application to spacecraft mechanism design") at the MRS Fall Meeting, Boston, Mass.

April 17-21, 1989

E W Roberts gave an invited presentation on "Ultra-low-friction films of MoS<sub>2</sub> for space applications" at ICMC '89, San Diego. TIWG meetings were also attended in this period at the same venue.

May 16, 1989

A TIWG meeting was held at NCT. US representatives were L Fehrenbacher, L Pope and M Hilton.

May 19, 1989

Mike Hilton (Aerospace Corp.) and Carl Mecklenburg (USAF) visited NCT for discussions regarding NCT programmes.

May 22-26, 1989

W H Roberts and E W Roberts attended a SCORE meeting in Northumberland House, London at which E W Roberts gave a presentation entitled "The potential of dry-lubricated ceramics for space".

October 24, 1989

R A Rowntree gave a presentation entitled "Transition of tribomaterials technology to gimbal demonstration programme" at the 6th SCORE meeting held in Los Angeles.

November 28 - December 1

E W Roberts attended a USAF Technical Review Meeting at Holiday Inn, Fairborn and gave two presentations on "Ultra-low friction films on modified substrates" and "Advanced tribological coatings for high specific strength substrates".



Appendix 3. MoS<sub>2</sub> coatings prepared at NCT for US companies.

The following lists coatings which have been prepared by NCT for US companies participating in the USAF programme. The coatings in all cases were of sputtered MoS<sub>2</sub> deposited to a thickness of nominally one micron. The cost of undertaking this coating work was borne by the present contract.

Date	Company	Substrates
3.12.87	Aerospace Corp. El Segundo.	Twenty steel substrates
4.12.87	Sandia National Labs.	Six circular steel substrates.
24.3.88	Aerospace Corp.	Twenty steel substrates
28.3.88	Hohman Plating Dayton, Ohio	Two steel test rings.
4.5.88	Hohman Plating	One steel test ring.
19.5.89	NRL, Washington	Five test rings.
1.6.88	NRL, Washington	Four small steel substrates.
11.1.89	Aerospace Corp.	Steel flats for indentation tests.
19.1.89	Sandia Natl. Labs.	Two 440C discs.
26.1.89	Aerospace Corp.	Eleven steel coupons.
31.1.89	Hohman Plating	Six test rings.
21.2.89	NRL, Washington	Twelve steel flats.
25.5.89	Los Alamos Natl. Lab.	Three thrust washers for laser treatment.
20.6.89	Aerospace Corp.	SR8 bearings and balls Four Andrews steel bearings (lost in transit).
22.8.89	Lockheed	Three thrust washers Forty four steel balls Three steel flats.
8.11.89	Aerospace Corp.	Kapton samples.

Appendix 4. Annual Technical Report 1988, NCT report No. 1488/531

Prepared for: The European Office of  
Aerospace Research and  
Development.  
223/231 Old Marylebone Rd.  
London NW1 5TH

Date: 30 April 1988

Dept. of Air Force reference: F49620-87-C-0076

ULTRA-LOW-FRICTION FILMS ON  
MODIFIED SURFACES.

ANNUAL TECHNICAL REPORT

Report No. 1488/531

Prepared by: B J Williams, E W Roberts

Approved by: W H Roberts



## Contents

1. Introduction
  2. Description of Tasks Undertaken
    - 2.1 Review of European Space Tribology
    - 2.2 Installation and Commissioning of a Sputter-coating System
    - 2.3 Initial Results of Round-Robin Exercise
      - 2.3.1 Round-Robin Exercise
      - 2.3.2 Test Apparatus and Conditions
      - 2.3.3 Test Samples
      - 2.3.4 Results
  3. Future Work
  4. References.
- Appendix 1 Professional personnel associated with project.
- Appendix 2 Meetings
- Appendix 3 Financial Forecast  
(1 Oct.'88 - 29 Sept.'89)

## **1. Introduction**

This report details the work undertaken in the period 1 July '87 to 30 April '88 under contract No. F49620-87-C-0076 entitled "Ultra-low-friction films on modified surfaces".

The main objectives of the proposed work are, firstly, to carry out an assessment of European space tribology and, secondly, to improve the tribological properties of ultra-low-friction films through modifications to the underlying substrate.

The proposed work comprises the following activities :

- (a) The preparation of a review detailing the current status of European space tribology.
- (b) The procurement, installation and commissioning of an RF, magnetron, sputter-deposition system.
- (c) The validation of the sputtering process and the deposition of MoS<sub>2</sub> films.
- (d) The tribological assessment of steel, ceramic and light metal alloy samples coated with validated MoS<sub>2</sub> films.
- (e) The sputter-deposition of low friction films onto modified surfaces.

In addition to the above tasks, the contract calls for collaboration and co-ordination of activities with U.S. researchers. Though the nature and extent of these activities were undefined at the start of contract a collaborative programme of work has now been established involving the participation of several U.S. establishments and the National Centre of Tribology (NCT). This programme has taken the form of a "round-robin" exercise which is still underway, the object of which is to test and characterise molybdenum disulphide films formed by different sputtering processes.

## **2. Description of Tasks Undertaken**

### **2.1 Review of European Space Tribology**

A draft copy of this review, entitled " A review of European trends in space tribology and spacecraft mechanism technology " has been completed and issued (NCT Report 988/526) to Tribology members of the Materials and Structures Sub-Group for comment.

The review covers fluid and dry lubrication, tribological components and spacecraft mechanisms. It is based on literature published openly over the last ten years.

## 2.2 Installation and Commissioning of a Sputter-coating System

A Nordiko NM-1500 sputter-coating rig was installed at NCT in December 1987. It consists of a vacuum chamber in which is fitted a single 8-inch diameter magnetron sputtering target. RF power is supplied at 13.56 MHz and the system is fitted with a power splitting unit which allows the RF power to be directed to either the target (for deposition), the substrate (for sputter-etching), or both simultaneously (bias sputtering). The chamber is pumped by an Edwards 2-stage rotary pump and a CTI Cryotorr 8 cryogenic pump. Additional features include a Meissner coil around the target to trap out any residual water vapour, and a rotary feedthrough complete with motor drive. Plate 1 shows the layout of the Nordiko Rig.

Some initial troubles were experienced due to faults with the rotary pump and incorrectly rated overload trips, but these were corrected by the supplier in the early stages of commissioning.

During December/January characterisation of the vacuum system took place. A V.G. Anavac-2 mass spectrometer was fitted to one of the viewports in the chamber wall to obtain measurements of the base pressure and the partial pressure of water vapour in the chamber. Base pressures of  $8 \times 10^{-8}$  torr were recorded after approximately 36 hours continuous pumping, the partial pressure of water vapour being down to  $5 \times 10^{-8}$  torr.

In January 1988 the substrate holder and MoS<sub>2</sub> sputtering target were installed (the target was obtained from Testbourne Ltd. Basingstoke, Hampshire). The base pressure and partial pressure of water vapour were monitored following target outgassing. After 8 hours outgassing at an RF power of 1.0kW and sputtering gas pressure of  $1.6 \times 10^{-2}$  torr, the base pressure and partial pressure of water vapour in the chamber were less than those of the "clean" chamber immediately after delivery. After further outgassing, base pressures of  $3.3 \times 10^{-8}$  torr were recorded together with a partial pressure of water vapour of  $7.6 \times 10^{-9}$  torr.

Following this target outgassing, samples of sputter-deposited MoS<sub>2</sub> were prepared and examined by scanning electron microscopy (S.E.M.) and X-ray photoelectron spectroscopy (X.P.S.). The films were produced at an RF power of 1kW and an argon pressure of  $1.6 \times 10^{-2}$  torr. All the films examined by S.E.M. appeared to have a globular-like structure, resembling the "type B" structure previously reported by Roberts (Ref. 1). Most of the globules were about 2-3 microns across, although some exceeded 10 microns. Many of the globules appeared to comprise smaller, sub-micron "micro-globules", whose sizes were too small to measure accurately.



Two of the three films examined by X.P.S. were sulphur-rich; the S/Mo ratios ranged between 1.85 - 2.30 . Initially, X.P.S. indicated only slight oxidation of Mo in these films. However, the films proved susceptible to surface oxidation in dry air at room temperature, with the S/Mo ratio falling significantly during storage over several weeks. This was accompanied by evidence of increased oxidation of Mo. It is of interest to note that the initial oxidation state appears not to be  $\text{MoO}_3$  , but some species in a lower oxidation state. It is possible that the partly oxidised surface is equivalent to  $\text{MoOS}_2$  or  $\text{Mo}_2\text{O}_5$  .

Glass slides coated with  $\text{MoS}_2$  were fractured under liquid nitrogen and examined by SEM to obtain measurements of the film thickness. Such measurements indicate the deposition rates to be in the order 1000 Å / min. These are appreciably higher than deposition rates obtained with conventional (non-magnetron) RF sputtering, where rates of 200 Å / min are typical.

Further characterisation of the coating process will take place in the near future.

## 2.3 Initial Results of the Round-Robin Exercise

### 2.3.1 Round-Robin Exercise

The purpose of the round-robin exercise is to test molybdenum disulphide films produced by the following suppliers.

National Centre of Tribology (NCT), UK.  
Aerospace Corporation, USA.  
Hohman Plating, USA.

Each supplier will fabricate two types of sputtered  $\text{MoS}_2$  film. NCT is supplying "good" and "bad" films fabricated according to their "optimised" and "non-optimised" processes respectively. Aerospace Corp. are supplying films produced at two substrate temperatures using conventional (non-magnetron) RF sputtering, whilst Hohman Plating are producing films with and without nickel through the use of DC sputtering techniques (inclusion of nickel is believed to increase film lifetime).

These films will be tested at the following establishments.

NCT, UK: pin-on-disc tests under high vacuum  
Aerospace Corp., USA.: tests in nitrogen in a flat-on-flat configuration.  
Hohman Plating, USA.: tests in air using a flat-on-cylinder configuration.  
Naval Research Labs., USA.: tests in air using a four-ball tester and flat-on-cylinder tester.



Sandia National Labs., USA.: wire-on-flat tests under ultra-high vacuum.

We report here some initial results obtained on the NCT pin-on-disc apparatus for tests on samples supplied by Aerospace Corp. and Hohman Plating.

### 2.3.2 Test Apparatus and Conditions

A pin-on-disc rig was used to perform friction tests on the sputter-coated MoS<sub>2</sub> films. The pin-on-disc rig can be seen in Plate 2 and is depicted in schematic form in Figure 1. Referring to the latter: a coated thrust washer is held in the upper sample holder (1) and three 7mm diameter steel balls are held in the lower ball holder (2), the latter being secured to the shaft of a Teldix DG 1.4 torque transducer (3). The balls are brought into contact with the disc and the required load is applied by a spring (4). Rotary motion is transmitted to the disc by means of the ferro-fluidic feed-through (5), flexible coupling (6) and bearing assembly (7).

The rig is fitted in a vacuum chamber, the pressure reduced to, typically,  $5 \times 10^{-7}$  torr and the disc rotated. The torque generated during the test is measured by the transducer and relayed to the chart recorder. Friction coefficient and revolutions-to-failure are recorded. For the purpose of the experiments reported here, film failure was defined as that point, following running-in, at which the friction coefficient exceeded 0.1.

The discs had the following specification:

Type	: shaft locating thrust washers.
Material	: EN31 ball bearing steel (52100 AISI)
Hardness	: Diamond microhardness $860 \pm 10$ Vickers. (HRC 58-65)
Surface Finish	: Radial 0.15 micron centre line average (CLA). Circumferential 0.10 micron CLA.

The discs were spring-loaded to 80N against three, equispaced, un-coated, EN31 steel balls. A rotational speed of 400 rpm was employed.

### 2.3.3 Test Samples

The films tested thus far have been supplied by Aerospace Corp. and Hohman Plating.

Aerospace Corp. have supplied the following MoS<sub>2</sub> films produced by RF sputtering:

AT 1B:	1 micron thick film produced at ambient temperature (AT)
HT 1B:	1 micron thick film produced at high temperature (HT)

AT 6B: 6 micron thick film produced at ambient temperature (AT)

HT 6B: 6 micron thick film produced at high temperature (HT)

Hohman Plating have supplied the following MoS<sub>2</sub> films produced by D.C. sputtering:

Lot no.9: 1 micron thick film of MoS<sub>2</sub>.

Lot no.13: 1 micron thick film of MoS<sub>2</sub> co-sputtered with nickel.

Lot no.12: 6 micron thick film of MoS<sub>2</sub>.

Lot no.16: 6 micron thick film of MoS<sub>2</sub> co-sputtered with nickel.

All the above films were deposited on 52100 steel discs whose specifications are given in 2.3.2.

### 2.3.4 Results

The results of the endurance tests are shown in Figures 2-4 and summarised in Table 1.

It can be seen from the results that all the samples tested for endurance on the NCT pin-on-disc rig showed similar trends, in that after an initial running-in period of about 1000 revolutions, the friction coefficients fell to within a range of 0.01-0.03 and remained at that level until failure. In all cases failure was characterised by a rapid increase in friction coefficient.

Examination of the results obtained with the Aerospace samples (Fig.2) indicates that the films produced at ambient temperature exhibited longer endurance than those produced at high temperature. There is, however, little evidence to indicate increased endurance with increasing film thickness. It should be stressed that the results corresponding to sample Ae HT 1B, which failed following 13,000 revolutions, should be treated as provisional as it became evident upon test completion that the screws securing the pin holders had vibrated loose during testing. This sample will be re-tested using an un-worn track in due course. In general, it was observed that the friction coefficient associated with Aerospace films gradually decreased reaching a minimum value of about 0.02 at a sliding distance corresponding to about half the ultimate film endurance.

Results obtained when testing the Hohman samples (Fig.3) indicated a similar trend with the friction coefficient displaying a minimum following about 40,000 disc revolutions. The addition of nickel in the "1 micron" Hohman samples appears to increase the effective endurance of the film from 86000 revolutions to 130000 revolutions. However, a somewhat contrary result arose in



the 6 micron tests in that the MoS<sub>2</sub> sample (lot no.12) lasted longer than its Ni co-sputtered equivalent (lot no. 16).

Fig.4 allows direct comparison of the Aerospace and Hohman film performances. It indicates that all the Hohman films examined exhibited longer endurance than the best performing Aerospace film and that, on average, the Hohman films gave rise to a slightly lower friction coefficient. However, it would be premature to conclude on the basis of the limited number of tests performed thus far that the observed order of performances is correct. Further tests are planned in order to obtain statistically meaningful data.

### 3. Future Work

Future work shall include:

- a) the continuation of the tribological assessment of MoS<sub>2</sub> films produced in the "round-robin" exercise.
- b) the fabrication of MoS<sub>2</sub> films for spectroscopic analysis by various groups participating in the "round-robin" exercise.
- c) the optimisation and validation of the MoS<sub>2</sub> sputtering process as carried out on the new Nordiko rig.
- d) the tribological testing of MoS<sub>2</sub> films applied to various substrates. These shall include 52-100 steel, 440C steel, Ti alloy (IMI 318) and silicon nitride. Disc-shaped substrates (together with pin-shaped samples) of these materials have been procured (Plate 3) and are ready for coating on completion of activity (c) above. These will then be assessed in NCT's pin-on-disc apparatus.
- e) the carrying-out of surface/interface modifications to MoS<sub>2</sub>-coated substrates with a view to improving film endurance. This work shall include the ion-beam mixing of MoS<sub>2</sub>/substrate interfaces. To this end, use will be made of Salford University's ion beam facilities, for film modification, and Rutherford Backscattering Spectrometer for compositional analysis of the modified interfaces.



#### 4. Reference

1. ROBERTS, E.W., "Towards an optimised sputtered MoS<sub>2</sub> lubricant film", 20th Aerospace mechanisms symposium, N.A.S.A., Cleveland, Ohio, May 1986.

**Appendix 1 Professional personnel associated with project.**

**Project Manager:**

Dr W H Roberts, BSc, PhD, C Phys, F Inst P  
Manager, NCT.

**Senior Researchers:**

Dr E W Roberts, BSc, PhD, C Phys, M Inst P  
Professional Grade 2.

Dr R A Rowntree, BSc, PhD, A I Mech E.  
Professional Grade 2.

**Researchers:**

Dr B Price, BSc, PhD  
Professional Grade 3

B J Williams  
Professional Grade 4

## Appendix 2 Meetings

The following interactions took place during the report period.

Mr K Carnahan, SDI consultant, visited NCT on 13 August, 1987 to discuss progress on the contract.

W H Roberts, E W Roberts and R A Rowntree attended a SCORE meeting in Dayton, Ohio in the period 7 September, '87 to 10 September, '87. Dr W H Roberts gave a formal presentation on contract activities. In a separate meeting at the same venue E W Roberts and R A Rowntree gave presentations on ultra-low-friction films and their applications to Tribology members of the Structure and Materials Sub-Group.

E W Roberts and R A Rowntree visited the Naval Research Laboratories, Washington on 11 September, '87 and gave presentations on ULF films and their application to high specific strength alloys. This meeting was hosted by I Singer.

E W Roberts and R A Rowntree gave presentations at the Army Materials Laboratory, Boston on 14 September '87. Discussions were held with P Fopiano and K Gabriel.

I Singer of NRL, Washington visited NCT on 25 September, '87 for technical liaison regarding the SDI tribology programme.

T Stewart of Aerospace Corporation, USA visited NCT on 8 October, '87 to discuss NCT's SDI activities.

Mr D Carre of Aerospace Corporation, USA visited NCT on 11 January, '88 to discuss project requirements.

W H Roberts, E W Roberts and R A Rowntree attended a SCORE meeting in London on 11 and 12 April '88. W H Roberts presented an update on NCT's SDI-related activities.

On 18 and 19 April '88 a meeting was held at NCT to review progress made on the SDI Tribology programme. This meeting was attended by NCT staff and the following US representatives : P Fleischauer (Aerospace Corp.), L Fehrenbacher (SDI consultant), I Singer (NRL), L Pope (SNL), K Gabriel (Army Matls. Lab.), B McConnell (AFWAL) and J Hansen (EOARD).



**Appendix 3 Financial Forecast:**  
**1 October '88 - 29 September '89.**

Research Item: 0001AC

Cost Estimate Summary

	<u>\$k</u>
Effort	89
Materials, supplies	-
Specific	34
Others	3
Equipment	-
Travel	13
US	13
UK	4
	----
Sub-total	143
Fee	7
	----
Total	150

Effort Estimate Summary

<u>Category</u>	<u>Level of Effort (man-days)</u>	
	Current Estimate <sup>1</sup>	Original Estimate <sup>2</sup>
Project Manager	11	14
Senior Researcher	60	74
Researcher	139	170

Notes: (1) based upon \$1.65/£  
 (2) based upon \$1.875/£

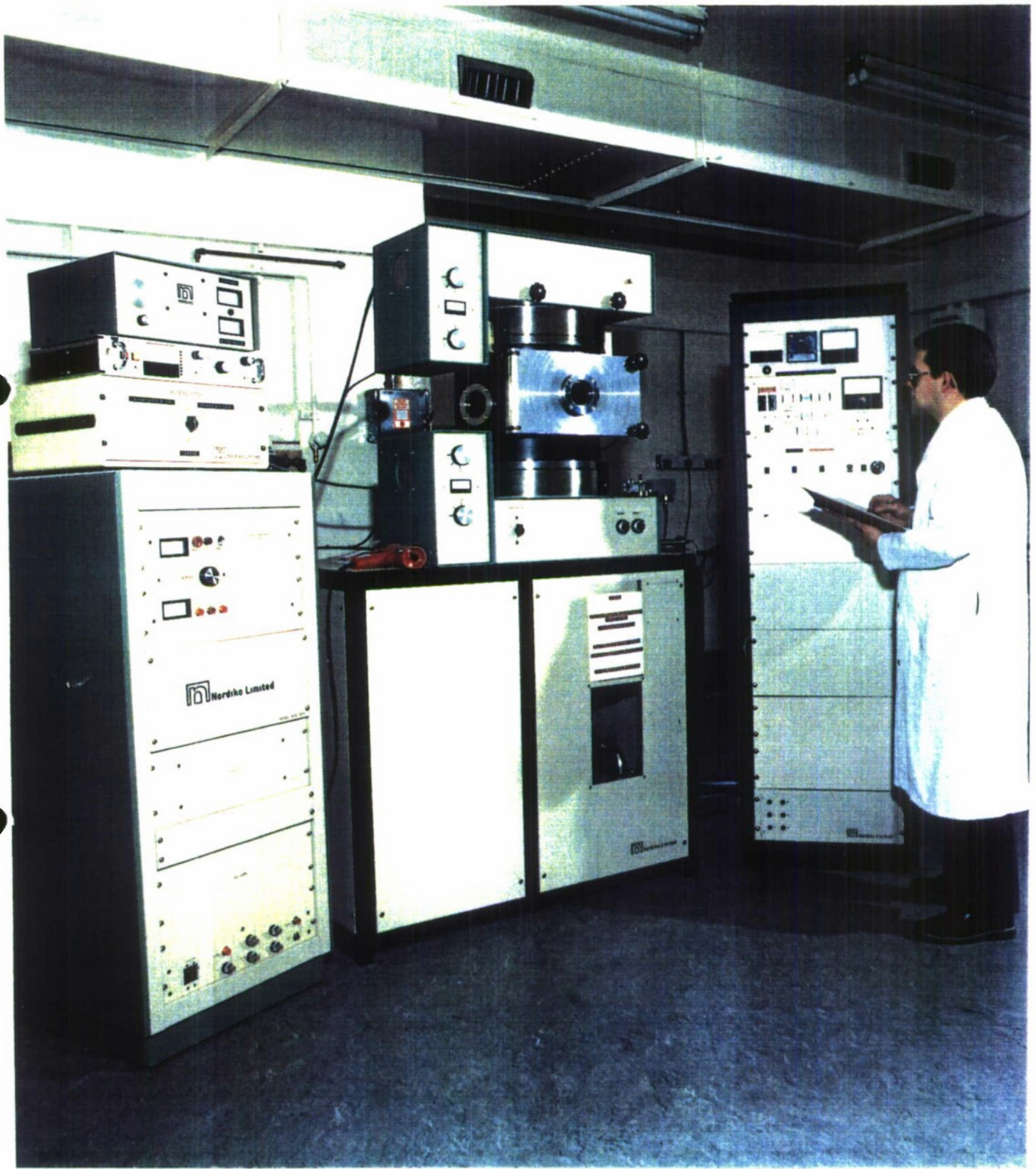


PLATE 1



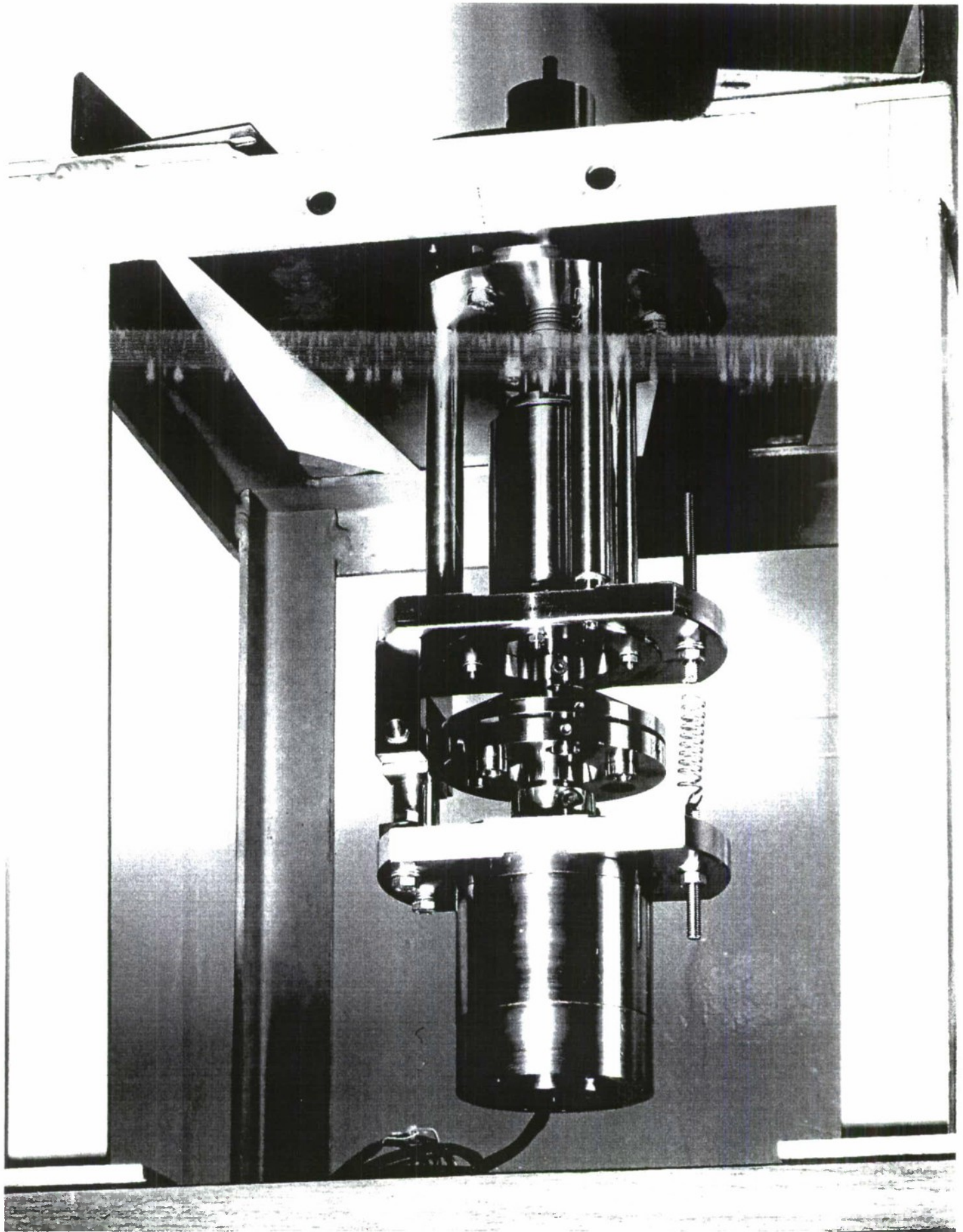
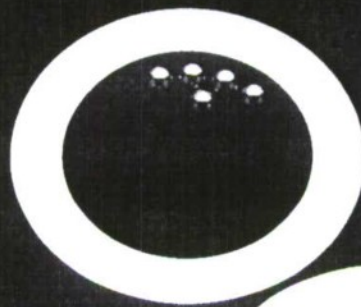


PLATE 2



52-100



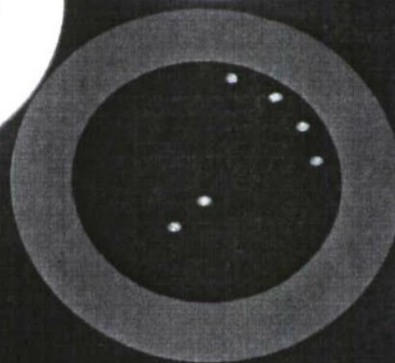
IMI 318



440C



$\text{Si}_3\text{N}_4$



NCT PIN-ON-DISC TEST

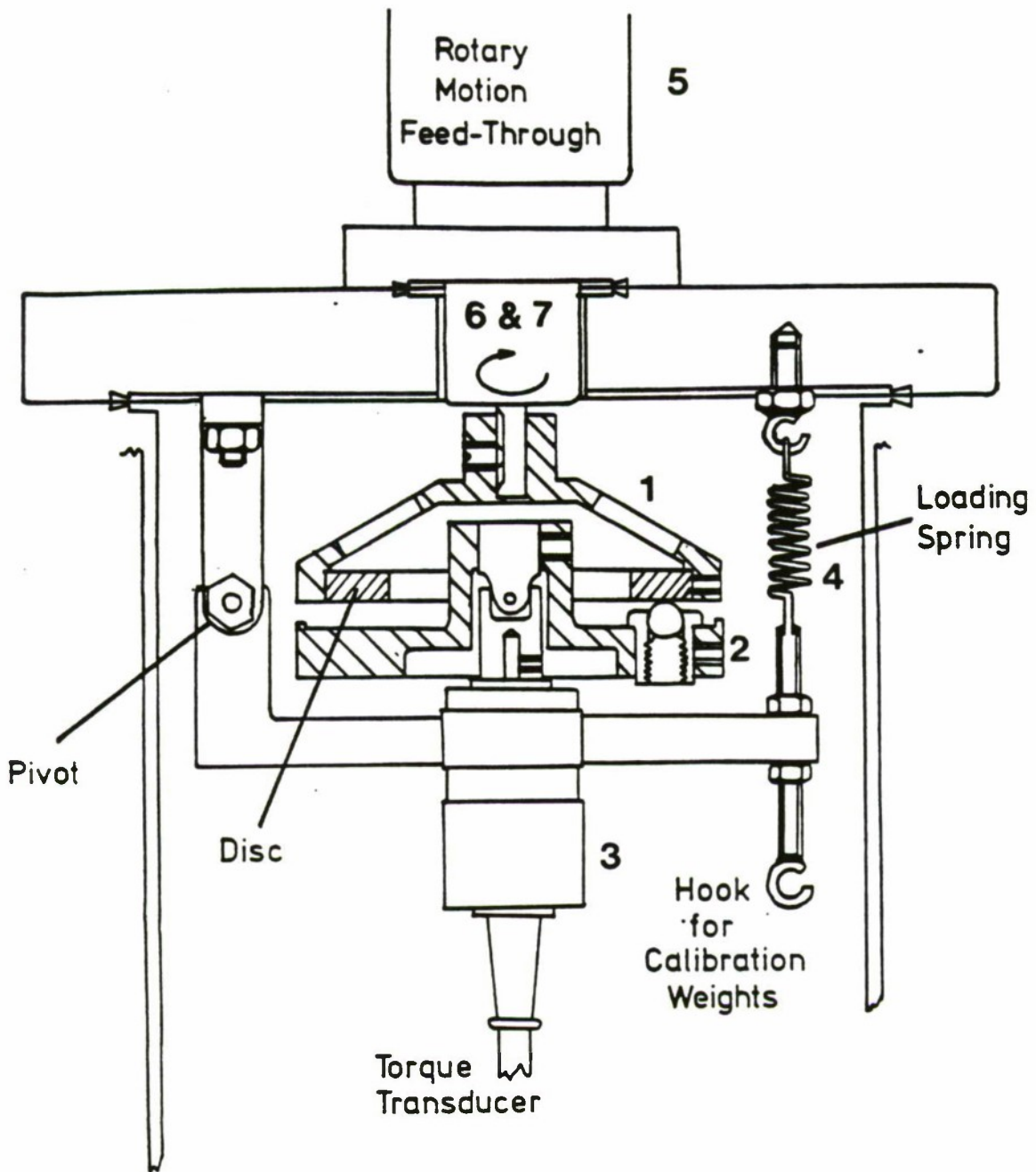
SAMPLE	FILM TYPE	THICKNESS (MICRONS)	RANGE OF FRICTION COEFFICIENT (PRIOR TO FAILURE)	TEST TERMINATED (REVS)
HOHMAN lot 9	MoS2	1.0 - 1.5	0.012 - 0.026	86,000
Ae AT 1B	MoS2	1.42	0.010 - 0.021	77,000
Ae HT 1B	MoS2	1.53	0.022 - 0.027	13,000
HOHMAN lot 13	MoS2 +Ni	1.0 - 1.5	0.014 - 0.025	113,000
Ae AT 6B	MoS2	6.17	0.015 - 0.031	45,000
HOHMAN lot 12	MoS2	6.0 - 6.5	0.015 - 0.032	156,000
Ae HT 6B	MoS2	7.22	0.020 - 0.030	42,000
HOHMAN lot 16	MoS2 +Ni	6.0 - 6.5	0.010 - 0.021	120,000

LOAD - 80 N

SPEED - 400 RPM

PRESSURE <  $5 \times 10^{-7}$  TORR

SUBSTRATE - 52-100 THRUST WASHER



Pin-on-Disc Rig

FIG.1



**NCT PIN-ON-DISC TESTS**  
 80N LOAD, 400RPM, < 5E-7 TORR

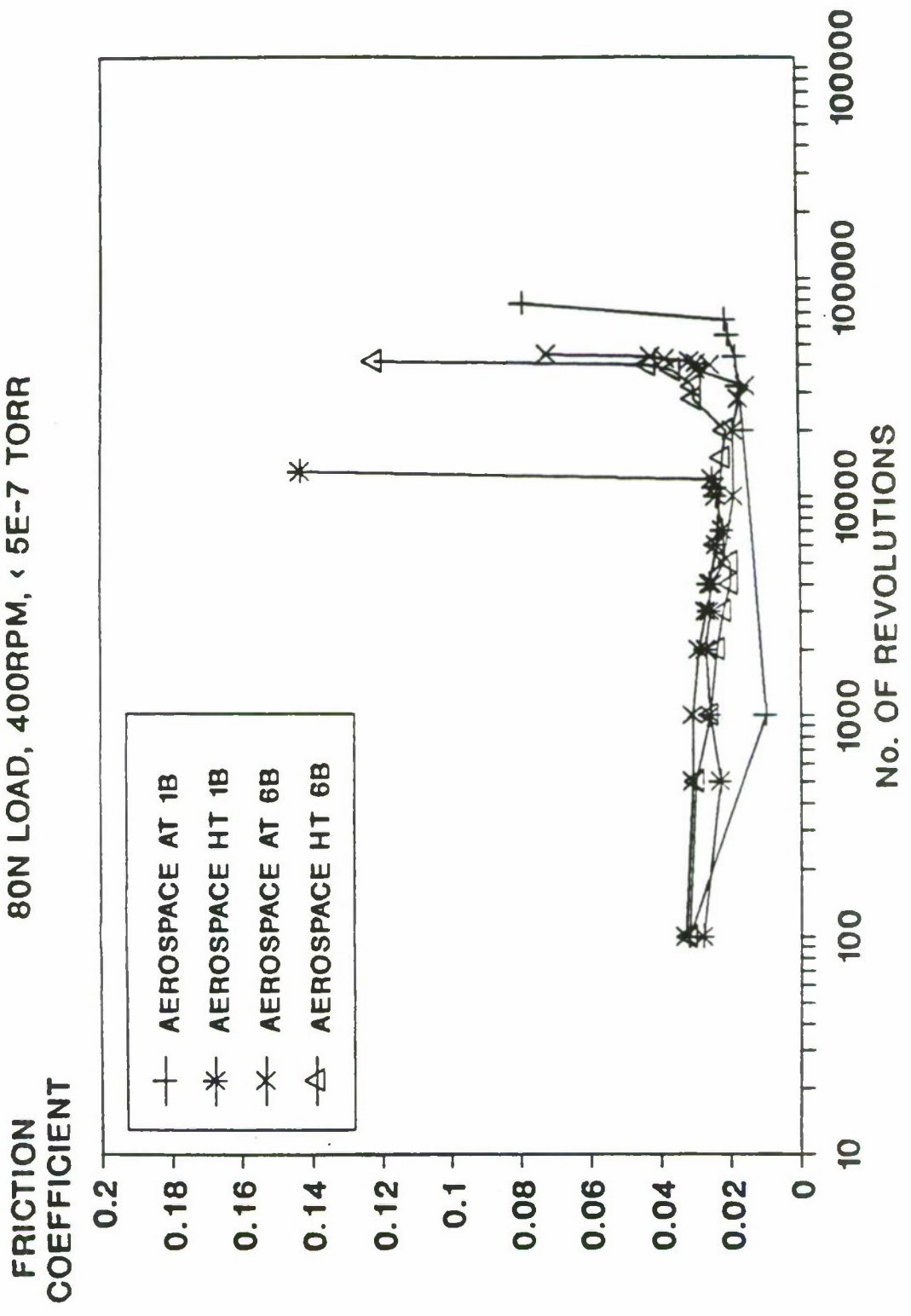


FIG 2

# NCT PIN-ON-DISC TESTS

80N LOAD, 400RPM,  $< 5E-7$  TORR

FRICITION  
COEFFICIENT

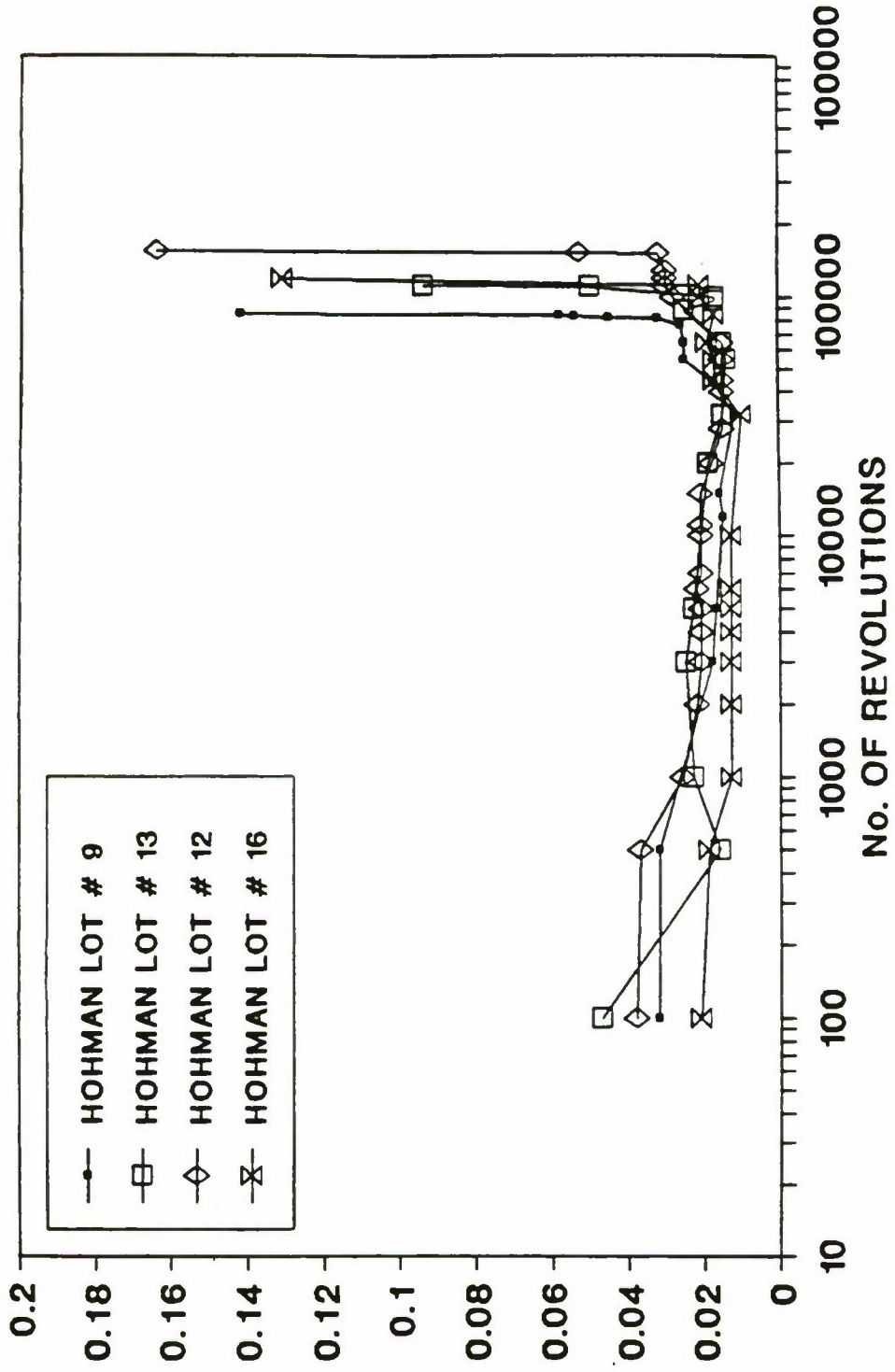
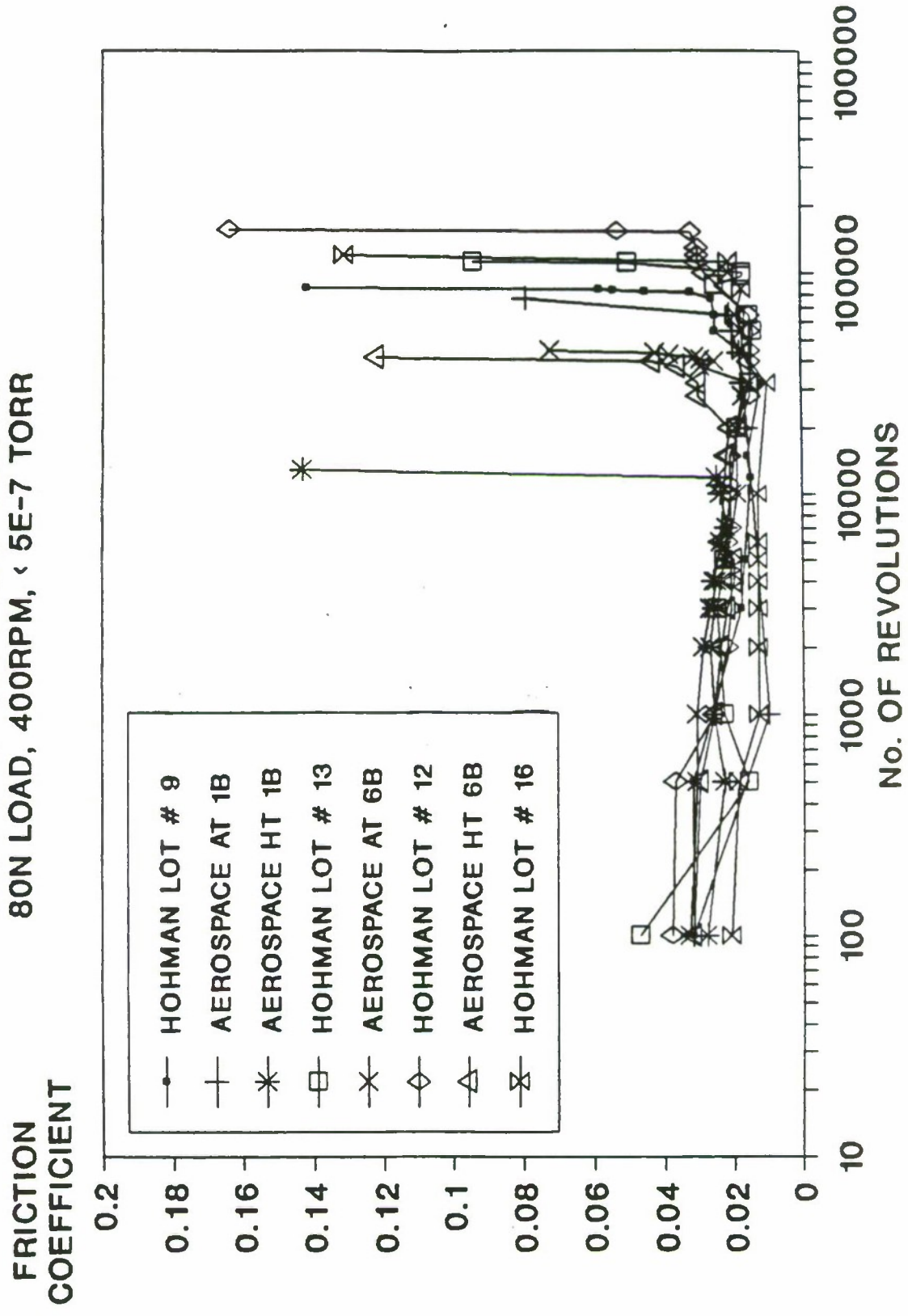


FIG 3

# NCT PIN-ON-DISC TESTS

80N LOAD, 400RPM, < 5E-7 TORR





Appendix 5. Annual Technical Report 1989, NCT report No. 1189/581

Prepared for: The European Office of  
Aerospace Research and  
Development.  
223/231 Old Marleybone Rd.  
London NW1 5TH.

Date: 30 April 1989.

Dept. of Air Force reference: F49620-87-C-0076

ULTRA-LOW-FRICTION FILMS ON  
MODIFIED SURFACES.

ANNUAL TECHNICAL REPORT  
'88/'89

Report No. 1189/581

Prepared by: B J Williams, E W Roberts, W B Price

Approved by: W H Roberts

## Contents

1. Introduction
2. Description of Tasks Undertaken
  - 2.1 The "Round-Robin" Exercise (continuation)
    - 2.1.1 Introduction
    - 2.1.2 Test Apparatus and Conditions
    - 2.1.3 Test Samples
    - 2.1.4 Results of the NCT Samples
    - 2.1.5 Comparison with Previous Results
  - 2.2 The Optimisation and Validation Exercise
    - 2.2.1 Introduction
    - 2.2.2 Test Procedures
    - 2.2.3 Test Samples
    - 2.2.4 Results
    - 2.2.5 Preliminary Conclusions
    - 2.2.6 Comparison of MoS<sub>2</sub> Films
  - 2.3 MoS<sub>2</sub> on Various Substrates
    - 2.3.1 Introduction
    - 2.3.2 Experimental Method
    - 2.3.3 Contact Materials
    - 2.3.4 Effects of Surface Roughness
    - 2.3.5 Tribological Measurements
    - 2.3.6 Surface Microscopy and Analysis
    - 2.3.7 Discussion
    - 2.3.8 Conclusion



3. Future Work
4. References
5. Appendix 1 - Professional personnel associated with project.
6. Appendix 2 - Meetings
7. Appendix 3 - Financial Forecast

## 1. Introduction

This report details the work undertaken in the period 1 May '88 to 30 April '89 under contract No. F49620-87-C-0076 entitled "Ultra-low-friction films on modified surfaces".

The work is a continuation of that reported in Annual Technical Report No. 1488/531 dated 30 April '88 and comprises the following activities :

- a) The continuation of the tribological assessment of molybdenum disulphide films produced in the UK / USA "Round-Robin" exercise.
- b) The optimisation and validation of the molybdenum disulphide sputtering process as carried out in the new Nordiko rig.
- c) The tribological testing of molybdenum disulphide films applied to various substrates including 52100 bearing steel, 440C stainless steel, IMI318 Titanium alloy and Hot Pressed Silicon Nitride (HPSN).

References will be made to the previous Annual Technical Report (ATR : 1488/531) where appropriate, in order to minimise repetition of already published results.

The object of this exercise remains, to test and characterise molybdenum disulphide films formed by different sputtering processes, and to assess the behaviour of the films on various underlying substrates.

## 2. Description of Tasks Undertaken

### 2.1 The "Round-Robin" Exercise (continuation)

#### 2.1.1 Introduction

The "round-robin" exercise was initiated in July '87 in order to compare the tribological properties of sputtered molybdenum disulphide films produced by the following suppliers :

National Centre of Tribology (NCT), UK.  
Aerospace Corporation, USA.  
Hohman Plating, USA.

Initial results obtained on the NCT pin-on-disc apparatus for tests on the samples supplied by Aerospace Corporation and Hohman Plating have been reported previously (ATR : 1488/531). We report here the results for the NCT films as tested on the NCT pin-on-disc apparatus.

#### 2.1.2 Test Apparatus and Conditions

The standard NCT pin-on-disc rig was used to perform friction tests on the sputter-coated MoS<sub>2</sub> films produced by NCT. A full description of this apparatus, together with photographs and schematic diagrams, can be found in ATR : 1488/531.

The disc samples comprised "shaft locating thrust washers" manufactured from EN31 ball bearing steel (52100 AISI) with diamond microhardness values of 860 ± 10 Vickers, and a circumferential surface finish of 0.10 micron CLA.

After coating, the discs were spring-loaded to 80N in the pin-on-disc rig against three, equispaced, un-coated, EN31 steel balls. A rotational speed of 400 rpm was employed as in the previous tests.

#### 2.1.3 Test Samples

The films produced and tested by NCT during this reporting period were as follows :

				Å/min
	:	NCT	1 micron Low rate	67
R.F.	:	NCT	1 micron Medium rate	434
Magnetron	:	NCT	1 micron High rate	500
Sputtering	:	NCT	6 micron Medium rate	434
	:	NCT	6 micron High rate	500

Note that the equivalent "6 micron Low rate" sample was not produced due to the excessive amount of time required to achieve 6 microns of film thickness at such a low deposition rate.

The friction and endurance behaviour of the above films were compared with those of films produced by Aerospace Corporation and Hohman Plating.

These films were deposited:

Aerospace :

AT 1B	---	Ambient temperature, 1 micron film	R.F. Sputtering
HT 1B	---	High temperature, 1 micron film	" "
AT 6B	---	Ambient temperature, 6 micron film	" "
HT 6B	---	High temperature, 6 micron film	" "

Hohman Plating :

Lot 9	---	1 micron thick film of MoS <sub>2</sub>	D.C. Triode Sputtering
Lot 13	---	1 micron thick film of MoS <sub>2</sub> co-sputtered with Ni	" " "
Lot 12	---	6 micron thick film of MoS <sub>2</sub>	" " "
Lot 16	---	6 micron thick film of MoS <sub>2</sub> co-sputtered with Ni	" " "

all of which were deposited on the same type of samples and run at the same test parameters as reported in section 2.1.2 .

#### 2.1.4 Results of the NCT Samples

The results from the endurance tests for the NCT samples are shown in Figure 1.

It can be seen from the results that after an initial running-in period of approximately 1000 disc revolutions, the 1 micron thick films exhibited a range of friction coefficients of 0.01 to 0.015 until the onset of failure. This was significantly lower than the friction observed with the thicker, 6 micron films. The range of film durabilities of the 1 micron films was large, varying from 42,000 disc revs. to 457,000 revs.

Both high-rate samples (along with the 6 micron medium-rate) performed well in the endurance tests - lasting in excess of 100,000 revolutions; the best performance coming from the 1 micron high-rate film which gave a range of friction coefficients between 0.008 - 0.013 before failing after some 457,000 revolutions.

#### 2.1.5 Comparison with Previous Results

The results obtained from the 1 micron films (Table 1) indicate :

a) the run-in values of friction coefficient lie in the range 0.007 to 0.026 whilst film durabilities range from 13,000 disc revolutions to 450,000 revs.



b) the lowest friction is observed on films produced by magnetron and AT R.F. sputtering.

c) films produced by D.C., AT/R.F., and medium-rate magnetron sputtering give comparable endurances in the order 70,000 disc revolutions. The poorest endurances are observed with films produced by low-rate magnetron and HT/R.F. sputtering. The highest endurance film and that displaying the lowest friction was produced by high-rate magnetron sputtering.

The results of tests on 6 micron thick films are summarised in Table 2. From this the following points emerge:

a) in general, friction coefficients are higher than those observed with 1 micron thick films, the values ranging from 0.014 to 0.044.

b) the best-performing films have durabilities which are, in general, only a little higher than those of the best-performing 1 micron thick films.

c) the films produced by non-magnetron R.F. sputtering are significantly less durable than films produced by D.C. triode and magnetron sputtering.

Our results point to two main conclusions. Firstly that film quality is a function of the sputtering process and secondly, increasing the film thickness to 6 micron does not bring about appreciable tribological gains: indeed the thicker films tend to produce higher friction.

This higher friction may arise because that component of load carried by the film itself increases as the film thickness increases. Thus the contact area will be determined not only by the deformation properties of the substrate but also, to a degree, by the deformation properties of the film. The elastic modulus of  $\text{MoS}_2$  is not known but will almost certainly be anisotropic as a consequence of  $\text{MoS}_2$ 's lamellar structure. It seems likely that, overall,  $\text{MoS}_2$  will have a lower modulus than bearing steel, in which case modest increases in contact area, and therefore friction coefficient would be expected. This effect is more discernible with softer lubricants such as lead where it is observed that the friction coefficient more than doubles on increasing the film thickness from 1 to 6 microns.

## 2.2 The Optimisation and Validation Exercise

### 2.2.1 Introduction

We present here the work carried out as part of an "Optimisation and Validation exercise" for the new Nordiko Sputter-coating rig. The main objectives of this exercise were :

- a) to perform **thickness calibrations** for the sputtering process at nine pre-defined sets of sputtering parameters; and
- b) to deposit 1 micron thick films of molybdenum disulphide onto **test samples** using the same nine sets of sputtering conditions as in a) and subsequently testing the samples to assess their tribological properties.

The purpose of this exercise was to select the sputtering pressures and power levels which yield a 1 micron thick film having the greatest endurance and lowest friction coefficient, (or the best compromise), of those under test. A comparison of the film's behaviour and performance was then made with similar films produced by the NCT sputtering rig.

The ultimate goal of the exercise was to produce sputtered films of  $\text{MoS}_2$  which were of at least equal quality to the "ULF" films produced in the NCT rig. However, our results indicate that whilst the films produced exhibited low friction coefficients, film endurances were inferior to those of the films produced in the NCT rig. Improvements have been made to the process which have increased the film's endurance under test and work is still continuing to improve the performance further.

### 2.2.2 Test Procedures

#### Power / Pressure Matrix

The maximum RF power available for sputtering is 1.2 KW and the range of argon sputtering pressures recommended by Nordiko is between 5 and 20 microns. Hence a "3 by 3" matrix of power / pressure was designed to give the nine operating conditions for the tests. The power / pressure matrix can be seen in Table 3. The sputtering conditions A-I were used for both the subsequent thickness calibrations and production of test samples.

#### Thickness Calibration

It was necessary to perform thickness measurements of the films deposited at each of the nine sputtering conditions prior to producing the test samples. This was so that the deposition rate at each set of conditions would be known, thus allowing all the samples to be coated with a nominally 1 micron thick film of  $\text{MoS}_2$ . The procedure for the thickness calibration was as follows:



Nine glass microscope slides were cleaned by washing, and then ultrasonic treatment in Arklone "P" solvent. The slides were loaded in turn onto the sample substrate of the Nordiko rig and the chamber pumped down to less than  $10^{-7}$  millibar pressure. The glass slide was then subjected to 15 minutes of sputter-etching at an RF power of 0.1 KW to ensure the cleanliness of the sample surface. The  $\text{MoS}_2$  target was then outgassed for a period of 45 minutes so as to drive off any residual water vapour. There followed sputter-deposition of  $\text{MoS}_2$  films onto the slide at the chosen sputtering conditions.

When the glass slides had been coated, thin, parallel bands of bitumen wax were painted across the surface to act as an etching mask. The  $\text{MoS}_2$  still exposed was then removed by etching in dilute nitric acid, leaving thin strips of  $\text{MoS}_2$  under their protective coverings of bitumen wax. The wax was removed by dissolving in toluene. Examination of the step-heights by Talysurf would then have given a measure of the thickness of the deposited film. However, because of the softness of the film, this measurement would have been unacceptably inaccurate. Therefore the whole slide was blanket-coated with a "flash" of titanium metal which allowed the talysurf stylus to traverse the slide without damaging the  $\text{MoS}_2$  coating.

The results of the thickness calibration can be seen in table 4 which illustrates the deposition rates achieved at the nine sets of sputtering conditions.

### 2.2.3 Test Samples

After having determined the respective deposition rates for all nine sets of sputtering conditions, there then followed the sputter-coating of a series of test samples with nominally 1 micron of  $\text{MoS}_2$  such that comparative tests could be performed.

The samples chosen for this exercise were shaft-locating thrust washers made from 52100 bearing steel which could then be tested in the NCT pin-on-disc rig and evaluated for their frictional performance in vacuum. The steel samples, labelled A.TW - I.TW were prepared, cleaned, sputter-etched and coated under the same conditions as their respective glass slide counterparts, the deposition time being previously calculated from the thickness calibration.

After coating, the samples were stored under clean conditions, bagged in dry argon until the time of testing.

### 2.2.4 Results

The samples were tested in vacuo in the NCT pin-on-disc rig under a load of 80 Newtons and at a rotational speed of 400 rpm, such that a direct comparison could be made with the previous test results reported in ATR : 1488/531 , (MOSSI).

It can be seen from Table 4 that deposition rates in the region of 1000 Angstroms per minute were achieved under the conditions C,E,F,H & I.

Table 5 shows the endurances of the sputtered films: areas D,E,G and H being the conditions producing the longest-running films.

Table 6 shows the average friction coefficients achieved during the optimisation tests. It can be seen that conditions A,D,E,F and H exhibited values of friction less than 0.015.

If the tabulations of deposition rates, friction coefficient and endurance are combined, the regions common to all three requirements of high deposition rate, low friction coefficient and long endurance can be found. These are the conditions of 0.8KW / 12.5 microns and 0.8KW / 20 microns, areas E and H respectively.

### 2.2.5 Preliminary Conclusion

The results would seem to suggest that an RF power of 0.8 KW together with a sputtering pressure of 16 microns of argon would produce the best films from the rig in terms of a long endurance, (39,000 revs) coupled with a relatively low friction coefficient, (0.013) and a reasonably fast deposition rate, (1000 Å/min).

### 2.2.6 Comparison of MoS<sub>2</sub> films produced by NCT and SDI sputtering rigs

Table 1 indicates that, depending on the sputtering conditions employed, the NCT sputtering rig gives rise to film endurances in the range 42,000 to 457,000 disc revolutions. When tested under the same conditions we observe that films produced by the SDI rig have endurances which range from 3,500 to 39,000 disc revolutions (Table 5). Thus films produced by the NCT rig exhibit, on average, an order-of-magnitude improvement in endurance over the durability of those films prepared in the SDI sputtering rig.

There appears therefore to be a rig-specific factor or factors which are instrumental in determining the tribological quality of MoS<sub>2</sub> films. It is therefore of interest to examine any differences that exist between the two sputtering rigs. The known differences are listed below.



	NCT rig	SDI rig
a) Pumping system	Diffusion	Cryogenic
b) Base Pressures	$10^{-6}$ torr	$10^{-7}$ torr
c) Target size	6" dia.	8" dia.
d) RF Power (normal)	900 W	800 W
e) Emitting area	4700mm <sup>2</sup>	7850mm <sup>2</sup>
f) Power density	0.2 W/mm <sup>2</sup>	0.1 W/mm <sup>2</sup>
g) Chamber volume (approx)	110 litres	67 litres
h) Target-to-substrate distance	55mm	70mm

Two differences in particular stand out. First, the base pressure in the "NCT" rig ( $10^{-6}$  torr) is an order of magnitude higher than in the "SDI" rig. Secondly, the power densities at the targets differ, the power density at the "NCT" target being twice that at the "SDI" target. Higher background pressures can be expected to give rise to increased film contamination whereas higher target power will give rise to higher target temperatures. The latter effect would lead to a more effective target outgassing.

Further insight was sought through chemical analyses of films prepared by both rigs. These analyses indicated:

- 1) As-sputtered "SDI" films are less contaminated with oxygen than as-sputtered "NCT" films.
- 2) X.P.S. analysis indicates that as-sputtered "SDI" films have higher sulphur-to-molybdenum ratios than as-sputtered "NCT" films. Thus "SDI" films had S/Mo ratios of between 1.9 and 2.05 whereas "NCT" films had ratios of between 1.8 and 1.9.
- 3) S.E.M. observations indicate that of the "SDI" films examined, none showed a columnar structure such as that associated with high-durability films produced in the "NCT" rig. Instead the films seemed mostly to consist of micro-spheres or globules or occasionally to exhibit an amorphous-like structure.

It would appear therefore that the "NCT" films differ primarily from the "SDI" films in that they are oxidised to a greater extent, and that they exhibit a columnar structure. Whilst it remains to be explained why such films should be tribologically superior, it seems clear that the differences in film structure and composition arise as a result of differences in sputtering conditions highlighted above. It is therefore planned that further tests be undertaken to elucidate the effects of power density and base pressure.

## 2.3 Performance of sputtered MoS<sub>2</sub> films on various substrates.

### 2.3.1 Introduction

The purpose of this exercise was to determine the efficacy of sputtered MoS<sub>2</sub> when applied to a variety of existing and potential bearing materials.

In a previous publication [1] it has been demonstrated that the higher deposition rates afforded by magnetron sputtering can be beneficial in the production of MoS<sub>2</sub> films. In that study the best-performing films under vacuum were those produced at high deposition rates (>450 Å/min). Those films produced at low deposition rates (<200 Å/min) were found to be sulphur-deficient and tribologically inferior.

For the purposes of the present study films of molybdenum disulphide of thickness 1 micron were produced at high deposition rates (>650 Å/min). An RF power of 0.9 kW was applied whilst the argon gas pressure was maintained at 20 microns. Such films were applied to disc samples made from four different bearing materials (a ceramic, two bearing steels and a titanium alloy). Prior to film deposition the substrate was ion cleaned (15 minutes at an RF power of 100 watts) so as to remove surface contaminants. The target was cleaned beforehand by sputtering for thirty minutes at the conditions of power and gas pressure subsequently used for deposition.

### 2.3.2 Experimental Method

#### Pin-on-disc measurements

A pin-on-disc apparatus was employed to undertake friction and wear tests under vacuum on the MoS<sub>2</sub>-coated discs. The coated discs were spring-loaded to 50 N against three, equispaced balls or hemispherically ended pins, each of diameter 7 mm. The discs were of annular shape (thrust washer geometry), the wear track being of 60 mm diameter. In each test the balls or pins were made of the same material as that of the disc. All tests were undertaken at a rotational speed of 400 rpm (1.2 m/sec). All pin-on-disc measurements were made under high vacuum (<5.10<sup>-7</sup> torr), this vacuum being achieved by evacuating the chamber initially by turbo-molecular pumping followed by ion-pumping.

#### Methods of surface and interface examination

Both X-ray photoelectron spectroscopy (XPS) and secondary ion mass spectrometry (SIMS) were employed for analytical examination of the interface region between film and substrate.

XPS was performed with a KRATOS Model ES 300 Electron Spectrometer, using Al K alpha radiation. For purposes of comparison a number of reference compounds were also examined. Powder samples were pressed into clean, lead foil prior to examination. Peak binding energies were estimated relative to the carbon 1s peak. This peak is normally taken to have a binding energy of 284.6 eV, and arises from deposition of traces of hydrocarbon residues such as pump oil vapours.



SIMS was performed using a Vacuum Generators secondary ion mass spectrometer, normally using an argon ion source to obtain spectra. The ionic fragmentation patterns produced by sputtering are characteristic of the chemical constituents of the surface. Comparison of SIMS spectra with those of reference compounds often permits identification of the species present. When no suitable reference compounds are available the SIMS spectra assist in indicating which atoms may be bonded to each other. The spectrometer can also be operated in a depth profile mode, to follow changes in composition through one or more layers on a surface.

Some secondary ion images were recorded using a liquid gallium ion source. This has a nominal beam diameter of 0.5 microns, compared with 50-60 microns for the argon beam, but at the expense of lower ion yields. These images show the distribution of species (elemental or molecular) across the surface being examined, and were useful for the examination of wear tracks on sections of thrust rings after pin-on-disc wear tests.

### 2.3.3 Contact Materials

Four types of substrate and pin (or ball) material were chosen for this study. These were silicon nitride, bearing steel - type 52100 (EN31), stainless steel - type 440C and a titanium alloy, IMI 318.

The silicon nitride discs were obtained from MATROC Advanced Materials Engineering Ltd. and were produced by hot pressing. Silicon nitride balls were procured from Spheric Engineering, these having been manufactured by hot isostatic pressing. Both the steel specimens were from NCT stock. Of these the 440C samples were subjected to hardening and tempering prior to testing. The titanium alloy specimens were machined from a bar of bulk material obtained from IMI Titanium Ltd., the alloy being of a 6% aluminum, 4% vanadium composition.

All disc samples were subjected to microhardness measurements prior to the deposition of sputtered molybdenum disulphide. Hardness measurements are given in Table A, together with values of elastic modulus.

\*\*\*\*\*  
 TABLE A  
 HARDNESS AND ELASTIC MODULI OF DISC MATERIALS (in GPa).  
 \*\*\*\*\*

MATERIAL	HARDNESS	ELASTIC MODULUS
SILICON NITRIDE	19.9	350
52100 STEEL	7.3	200
440C STEEL	8.8	200
Ti ALLOY (318)	3.2	106

\*\*\*\*\*

The surface finishes of the contact materials are discussed separately below.



### 2.3.4 Effects of surface roughness

To allow a meaningful comparison of the role played by the substrate materials in the functional behaviour of sputtered MoS<sub>2</sub>, it is imperative that the test conditions in each case be kept as near identical as possible. To this end contact load, sliding speed and vacuum pressure, all of which affect both the friction and endurance of sputtered MoS<sub>2</sub> films [2], were kept the same from run to run.

Consideration was also given to the surface roughness of the substrates, for it has been demonstrated [3] that the friction and endurance of burnished films of molybdenum disulphide are greatly affected by the surface finish of the substrate to which they are applied. In that study [3] MoS<sub>2</sub> films were burnished onto discs made from 440C steel having three values of surface roughness, 0.09, 0.30 and 1.2 micron (CLA values), corresponding to polished, sanded and sandblasted surfaces. It was found that increasing the surface roughness resulted in increases in film endurance for tests conducted in humid air and dry argon. Furthermore the friction coefficients measured in air were seen to be significantly roughness-dependent, the rougher surfaces giving rise to lower friction.

It seems reasonable to assume that the behaviour of sputtered films should likewise be affected by surface roughness. To test this assertion measurements of friction and endurance were made on sputtered MoS<sub>2</sub> films applied to steel (52100) substrates having surface roughnesses of 0.04 and 0.12 microns (CLA values). The test conditions were as described above, under Experimental Method. The results of these tests are shown in Fig. 3 in which are plotted values of friction coefficient as a function of number of disc revolutions. It can be seen that surface roughness affects both friction and film endurance. Application of an MoS<sub>2</sub> film to the rougher surface gives rise to a run-in friction coefficient of 0.01 and an endurance in excess of 10<sup>5</sup> disc revolutions. However a similar film applied to the smoother surface has a much reduced endurance and a higher friction coefficient (0.02) following running-in.

Thus it can be seen that the effect of surface roughness on the tribological characteristics of sputtered MoS<sub>2</sub> films is appreciable. In view of this, all substrates of the present study were prepared so as to give similar surface finishes. Of the four materials under examination the "as-received" specimens of silicon nitride exhibited the smoothest surface finish (CLA, 0.04-0.05 micron). To facilitate obtaining a uniformity of finish from substrate to substrate the remaining, non-ceramic substrates were polished to a roughness comparable to that of the silicon nitride surface. This choice of surface finish was further justified on the grounds that this level of surface roughness is representative of that of the contacting surfaces of many engineering components, in particular that of precision ball bearings.

\*\*\*\*\*

TABLE B  
SURFACE ROUGHNESS (IN MICRONS) OF TEST SUBSTRATES

\*\*\*\*\*

MATERIAL TYPE	SURFACE ROUGHNESS			
	AS-RECEIVED		AFTER POLISHING	
	CLA	RMS	CLA	RMS
SILICON NITRIDE	0.047	0.060	0.047	0.060
52100 STEEL	0.084	0.109	0.043	0.055
440C S.STEEL	0.34	0.45	0.035	0.046
Ti ALLOY (318)	0.34	0.45	0.045	0.057

\*\*\*\*\*

The test substrates had the surface roughness values given in Table B. We note that following polishing, the CLA and RMS values are closely similar. Fig. 4 shows a surface profile of the silicon nitride disc together with a scanning electron micrograph of its surface.

### 2.3.5 Tribological Measurements

Fig. 5 shows the variation of friction coefficient as a function of number of disc revolutions for sliding contacts of the four test materials lubricated with magnetron sputtered MoS<sub>2</sub>. From Fig.5 we make the following observations.

1) The endurance of the lubricant film is strongly dependent on the contact material. Thus the best performing combination (silicon nitride) exhibits an endurance which is a factor 200 higher than the poorest performer (titanium alloy).

2) The friction coefficient is significantly dependent on contact material, though this dependence is not as marked as that of the film endurance. The lowest friction is obtained with the combination of MoS<sub>2</sub> and silicon nitride, and the highest where titanium alloy is employed as the contact material.

3) Where the contact materials are metallic, film failure is signalled by an abrupt and rapid increase in friction coefficient. This is not the case with silicon nitride upon which film failure occurs gradually as evidenced by a slower increase in friction coefficient lasting some 50,000 disc revolutions. Indeed there is evidence that there occurs some recovery of the lubricating action, such that, following initial indications of film failure, the friction coefficient increases to 0.09 but then decreases to about 0.06.

### 2.3.6 Surface Microscopy and Analysis

Scanning electron microscopy showed that the MoS<sub>2</sub> film structure did not depend significantly on the type of substrate. All the films had a columnar structure in which the basal planes lie mainly perpendicular to the substrate surface. There were minor variations in the apparent widths of the columns (Fig.6), but it is thought doubtful that such variations could affect the film performance.



XPS and SIMS were used to examine the surface chemistry of MoS<sub>2</sub> films. Films of 1 micron thickness showed properties similar to those reported by Fleischauer [4,5], in that the film surfaces were readily oxidised in air at ambient temperatures. SIMS depth profiles indicated that the films contained some oxides of molybdenum throughout their depths. This oxide was probably incorporated during the sputter-deposition process. Sputtering is likely to cause partial fragmentation of MoS<sub>2</sub> into Mo and S atoms, most of which can be expected to recombine as MoS<sub>2</sub>. However, competing reactions may occur with impurity species in the vacuum chamber, especially oxygen or water vapour [6], leading to oxide formation.

Three methods were employed to study the interfacial chemistry between film and substrate. These were as follows:

a) The first method consisted simply of sputter etching the sample in the MoS<sub>2</sub> deposition chamber without any subsequent MoS<sub>2</sub> deposition. This results in the backscattering of MoS<sub>2</sub> which has been previously deposited near the sample holder. This method is not entirely reproducible or controllable. Other impurities are introduced by this mechanism, usually elements found in steel (derived from the sputter etching of specimen support brackets). However, XPS indicates that the levels of such impurities are generally low (< 1-2 atom %).

To demonstrate the efficacy of this method, the technique was applied initially to molybdenum disulphide "deposited" onto foils of pure iron as it was felt that the use of a simple, elemental substrate would allow an unambiguous interpretation of spectra. SIMS analysis of the "coated" surface indicated the existence of iron-sulphur bonding.

b) The second method was simply to sputter deposit MoS<sub>2</sub> by our routine method but to limit deposition to a very short time (1 sec.) so as to achieve a very thin film (a few monolayers).

c) The third and final method of studying interfacial chemistry was to examine wear tracks which had formed in MoS<sub>2</sub> films as a result of pin-on-disc testing. Only films deposited on 52100 steel were examined by this method.

Evidence of Fe-S bonding, similar to that observed with the iron foil specimen, was found, using method (c), in the wear tracks on a 52100 steel substrate. SIMS ion images indicated that the Mo (as MoS<sub>2</sub>) had been largely worn away from the wear track. However a residual amount remained within the track and exhibited evidence of Fe-S and Fe-S-Mo bonding which we attribute to chemical bonding between film particles and the substrate. We have considered the possibility that some of our SIMS observations might arise from effects induced by the ion beam; these effects could include sputter-mixing on the substrate surface, and gas phase reactions of sputtered fragments. If such effects were significant we would expect similar species to be formed regardless of whether the MoS<sub>2</sub> film was prepared by sputtering or burnishing. However, an extensive examination of burnished films failed to reveal any evidence of Fe-S or Fe-S-Mo bonding (Ref.7). Moreover, whilst SIMS can produce binary cluster ions as a beam-induced artefact, the operating conditions used for the present work have not previously been observed to induce the formation of 3 or 4 atom cluster ions such as FeMoS<sup>+</sup> or Fe<sub>2</sub>MoS<sup>+</sup>. Hence we conclude that our SIMS results offer evidence for chemical bonding between MoS<sub>2</sub> and certain substrates.



The above observations may account for the large differences between the endurance of burnished and sputtered MoS<sub>2</sub> films (Fig.2), in that the presence of interfacial bonds in the case of the sputtered film implies strong film-to-substrate adhesion and, conversely, the absence of such bonds with burnished films suggests poor adhesion.

Following deposition of an ultra-thin film of molybdenum disulphide by method (b) onto 440C steel, SIMS detected both Fe-S and Cr-S bonding.

The SIMS spectra from the Si<sub>3</sub>N<sub>4</sub> specimen indicated the presence of Si-S bonding, together with Mo-N bonding. Some oxidation of both Mo and Si was also evident. Thus, as with the steel specimens, it appears that sputter deposition can induce chemical bonding between MoS<sub>2</sub> film and the silicon nitride substrate. XPS provided supporting evidence to suggest that silicon-sulphur bonding occurred when ultra-thin-films of MoS<sub>2</sub> were sputter deposited on to silicon nitride.

SIMS analysis of MoS<sub>2</sub> deposits on the titanium alloy failed to identify the presence of any peaks which could be conclusively attributed to Ti-S bonding. It was observed that whilst all samples examined contained some surface oxide, the most oxidised surface was that of the titanium alloy.

### 2.3.7 Discussion

We now address the major findings of this study which are that the friction and endurance of sputtered MoS<sub>2</sub> films are appreciably affected by the type of contact materials lubricated by the films. First, we shall examine the relationship between film friction and the material properties of the sliding contacts.

#### Influence of substrate material on friction

The frictional force associated with sliding contacts lubricated with thin, solid films is given by the product of the film's shear strength and the true area of contact. We now make the reasonable assumption that the film's shear strength remains invariant with the type of material to which it is applied. This being so, it follows that any variations in the frictional properties of MoS<sub>2</sub> that arise on employing different contact materials are attributable to differences in true contact area. Since the contact area is governed by asperity deformation, and therefore by the elasticity or plasticity of the contact bodies, it follows that the friction of thin, MoS<sub>2</sub> films will be, and indeed is observed to be, dependent on the material properties of the contacting bodies.

We now ask whether the observed changes in friction coefficient are consistent with the deformation properties of the contact materials. The contact area can be calculated for elastically deforming bodies from the Hertz theory. For a sphere-on-flat configuration this gives,

$$\text{Contact area } A = \frac{3.W.R}{4.E^*} \quad (1)$$

where W is the contact load, R the radius of the sphere, E\* is the effective elastic moduli which for contacts of the same material equals  $E/2(1-\nu^2)$ , where E is the elastic modulus and  $\nu$ , Poisson's ratio.

However, this theory requires that the contacting bodies have perfectly smooth surfaces so that contact is confined to one interfacial area. The validity of applying the Hertzian equations to the contact in a pin-on-disc configuration, that of an unsmooth sphere loaded against an unsmooth flat, has been examined by Greenwood et al [8]. They concluded that the Hertz equations are applicable provided the following two conditions are met.

- a) That a "roughness" parameter be less than about 0.05, where
- $$\text{Roughness parameter} = \frac{r_q \cdot R}{a^2} \quad (2)$$

where  $r_q$  is the rms surface roughness of the flat and "a" is the radius of the contact area as calculated from the Hertz equations assuming both sphere and flat to be perfectly smooth.

- b) That contact between ball and flat is made at several contacting asperities.

Table C lists values of the Greenwood roughness parameter for the various contacts studied. We note that for all the materials examined, the roughness parameter does not exceed 0.05 and thus, assuming that actual contact is made at several points, the Hertzian equation describing contact area may be applied. These contact areas (per pin/substrate contact) have been calculated and are also given in Table C.

\*\*\*\*\*

TABLE C

CALCULATED ROUGHNESS PARAMETERS AND HERTZIAN CONTACT AREAS

\*\*\*\*\*

MATERIAL	ROUGHNESS PARAMETER	HERTZIAN CONTACT AREA ( $\times 10^{-8} \text{m}^2$ )
SILICON NITRIDE	0.045	1.42
52100 STEEL	0.035	2.05
440C S.STEEL	0.032	2.07
Ti ALLOY	0.021	3.03

\*\*\*\*\*

Using these values of contact area we plot in Fig. 7 the variation in friction coefficient with contact area. The spread in values of friction coefficient shown against each contact area is representative of the measurements made following film run-in, up to the onset of film failure. Fig. 7 demonstrates that the best fit curve (dotted line) is linear such that the friction coefficient is directly proportional to contact area. This is as predicted above and accounts for the observed dependence of the friction of MoS<sub>2</sub> films on the contact materials. The shear strength of the lubricant film is calculated from the gradient of the Fig. 7 plot to be 18 MPa. This compares with a value of 10 MPa determined earlier (Ref.9) for sputtered molybdenum disulphide applied to rougher surfaces (0.1-0.15 micron CLA) of 52100 steel.



In Fig.7 we have drawn the curves A and B to highlight the range of values of friction coefficient observed. In general the lowest values of friction coefficient for a given contact material, represented by curve A, are observed immediately after running-in (Fig.5), whilst the higher values (curve B) are observed after further sliding. A possible explanation of this behaviour is that initially the ball or pin is unworn, in which case the contact area is truly governed by the ball's radius of curvature. With further sliding the ball develops a wear scar (in the form of a "flat") whose radius of curvature will be larger than that of the ball itself. The contact area will, as a result, be increased thereby giving rise to higher friction.

#### Influence of substrate material on film endurance

We now consider the influence of the substrate material on film endurance. Table D shows mean values of endurance calculated following repeat pin-on-disc tests.

\*\*\*\*\*

TABLE D  
MEAN MoS<sub>2</sub> FILM ENDURANCES

\*\*\*\*\*

CONTACT MATERIAL	MEAN FILM ENDURANCE (DISC REVOLUTIONS)
SILICON NITRIDE	120,000
52100 STEEL	15,000
440C S.STEEL	7000
Ti ALLOY 318	400

\*\*\*\*\*

There is clearly a marked and quite remarkable dependence of film endurance on contact material, the range of endurance extending almost to three orders of magnitude.

It is noted that the contact material associated with the poorest film endurance, titanium alloy 318, is the only substrate material on which no evidence of substrate-to-film chemical bonding was detected. This strongly suggests that film adhesion is a critical factor in the determination of film durability. With the other substrate materials studied it appears that the chemically reactive species created by the sputtering process lead to bonding between the film and the substrate, giving rise to strong adhesion. We believe that this adhesion accounts, in part, for the improved film lifetimes obtained using the steel and ceramic substrates. However, there remains to be explained the large difference between the film durabilities observed with silicon nitride and steel substrates. Our S.I.M.S. analysis showed Si-to-S and Mo-to-N bonding on the silicon nitride, and Fe-to-S and Cr-to-S bonding on the steels. It is possible that differences in the strength or extent of this bonding are responsible for the different film durabilities.



Regarding the extent of bonding, it seems probable that the silicon nitride substrate offers a larger surface area compared to that of the steel substrates. Fig. 4 shows that the silicon nitride surface, despite having a surface roughness comparable to that of the steel surfaces, exhibits some degree of porosity. The porous nature of the silicon nitride surface will increase the number of sites at which bonding can occur and in addition will provide reservoirs in which deposits of  $\text{MoS}_2$  can reside and from which the lubricant may be released as the surface is worn away. Indeed this effect may well explain why  $\text{MoS}_2$  films applied to silicon nitride substrates do not fail in an abrupt and catastrophic manner - as occurs with metallic substrates (see Fig.5)

### 2.3.8 Conclusion

Films of magnetron sputtered molybdenum disulphide have been applied to ceramic and metal substrates and their tribological behaviour examined under high vacuum. It is observed that the friction coefficient decreases with increasing elastic modulus of the contact materials. This behaviour is ascribed to changes in true contact area. Film endurance is strongly dependent on substrate material, the highest endurance being observed for films deposited on silicon nitride substrates and the worst durability being obtained with films applied to titanium alloy substrates. Film durability appears strongly related to adhesion, as evidenced by the presence of interfacial chemical bonds on the steel and ceramic substrates and their absence on titanium alloy. These results show that the combination of sputtered molybdenum disulphide and silicon nitride gives a very favourable tribological performance under vacuum and one that augurs well for the future use of ceramic tribo-components in space.

### 3. Future Work

Future work in financial year 1989 shall include :

- a) Magnetron sputtering rig - continuation of the optimisation exercise shall take place in order to obtain further improvements in the film endurance. This shall include an investigation into the effects of power density on the sputtering targets and the subsequent performance of the films produced.
  
- b) "Round-robin" exercise - an investigation will be carried out into the effects of storage on the performance of the sputtered films. Sputter-deposited films from the three suppliers will be stored under dessicated conditions for periods up to twelve weeks from the initial deposition. The tribological performance of the films will then be examined.
  
- c) Surface / interface modifications - MoS<sub>2</sub>-coated substrates shall be subjected to surface/interface modifications. The ion-beam mixing and surface treating will be examined as ways of improving film endurance.

#### 4. References

1. E W Roberts "Towards an optimised sputtered MoS<sub>2</sub> lubricant film" Proc. 20th AMS, NASA Lewis, Cleveland, NASA Publ.2423, May, 1986.
2. E W Roberts "The tribology of sputtered molybdenum disulphide" Proc. I Mech. E. "Tribology - Friction, Lubrication and Wear, 50 Years On", London, July, 1987.
3. R L Fusaro "Effect of substrate surface finish on the lubrication and failure mechanisms of molybdenum disulphide films" ASLE Trans. 25, 141-156, 1982.
4. P D Fleischauer and R Bauer "Chemical and structural effects on the lubrication properties of sputtered MoS<sub>2</sub> films" Tribology Trans., 31, 239-250, 1988.
5. P D Fleischauer "Effects of crystallite orientation on environmental stability and lubrication properties of sputtered MoS<sub>2</sub> thin films" ASLE Trans. 27, 82-88, 1984.
6. V Buck "A neglected parameter (water contamination) in sputtering of MoS<sub>2</sub> films" Thin Solid Films, 139, 1986.
7. W B Price, E W Roberts and M J Todd, to be published.
8. J A Greenwood, K L Johnson and E Matsubara "A surface roughness parameter in Hertz contact", Wear, vol. 100, Dec. 1984.
9. E W Roberts "The lubricating properties of magnetron sputtered MoS<sub>2</sub>" ESA (ESTL) 76, Oct. 1987.



## Appendix 1 Professional personnel associated with project

### Project Manager:

Dr W H Roberts, BSc, PhD, C Phys, F Inst P.  
Manager, NCT.

### Senior Researchers:

Dr E W Roberts, BSc, PhD, C Phys, M Inst P.  
Professional Grade 1.

Dr R A Rowntree, BSc, PhD, A I Mech E.  
Professional Grade 1.

### Researchers:

Dr W B Price, BSc, PhD.  
Professional Grade 3.

B J Williams, BSc.  
Professional Grade 4.

## Appendix 2 Meetings

The following interactions took place during the reporting period.

On 13th May '88 Dr EW Roberts accompanied TIWG members on a visit to Plessey Research Centre (Caswell, U.K.) to discuss Plessey's work on diamond and diamond-like coatings.

Drs EW Roberts and RA Rowntree attended a TWIG meeting in Dayton, Ohio in the period 6 June - 10 June '88. Update reports were given, discussions held on proposed diamond coating work and component and mechanism demonstration programmes.

In the period 21 August - 30 August '88 Drs EW Roberts and RA Rowntree gave presentations on space tribology at several aerospace companies throughout the U.S.A.. They were accompanied by Messrs McConnell, Fleischauer, Pope and Fehrenbacher of TIWG.

Dr RA Rowntree attended and presented information on NCT's SDI activities at the SCORE meeting held in Huntsville, Alabama in the period 17 October - 21 October '88.

In the period 28 November - 2 December '88, Dr EW Roberts and Mr MJ Todd attended a TWIG meeting in Boston, Mass.. They also presented papers on NCT's SDI activities at the MRS symposium.

### Appendix 3 Financial Forecast

1 December '88 - 30 November '89.

Research Item : 0002AA

#### Cost Estimate Summary

	\$K
Effort	89
Materials, supplies	
Specific	34
Others	3
Travel	
U.S.A.	13
U.K.	4
	-----
Sub Total	143
Fee	7
	-----
TOTAL	150
	-----

#### Effort Estimate Summary

Category	Level of Effort (man-days)	
	Current Estimate <sup>1</sup>	Original Estimate <sup>2</sup>
Project Manager	13	14
Senior Researcher	69	74
Researcher	158	170

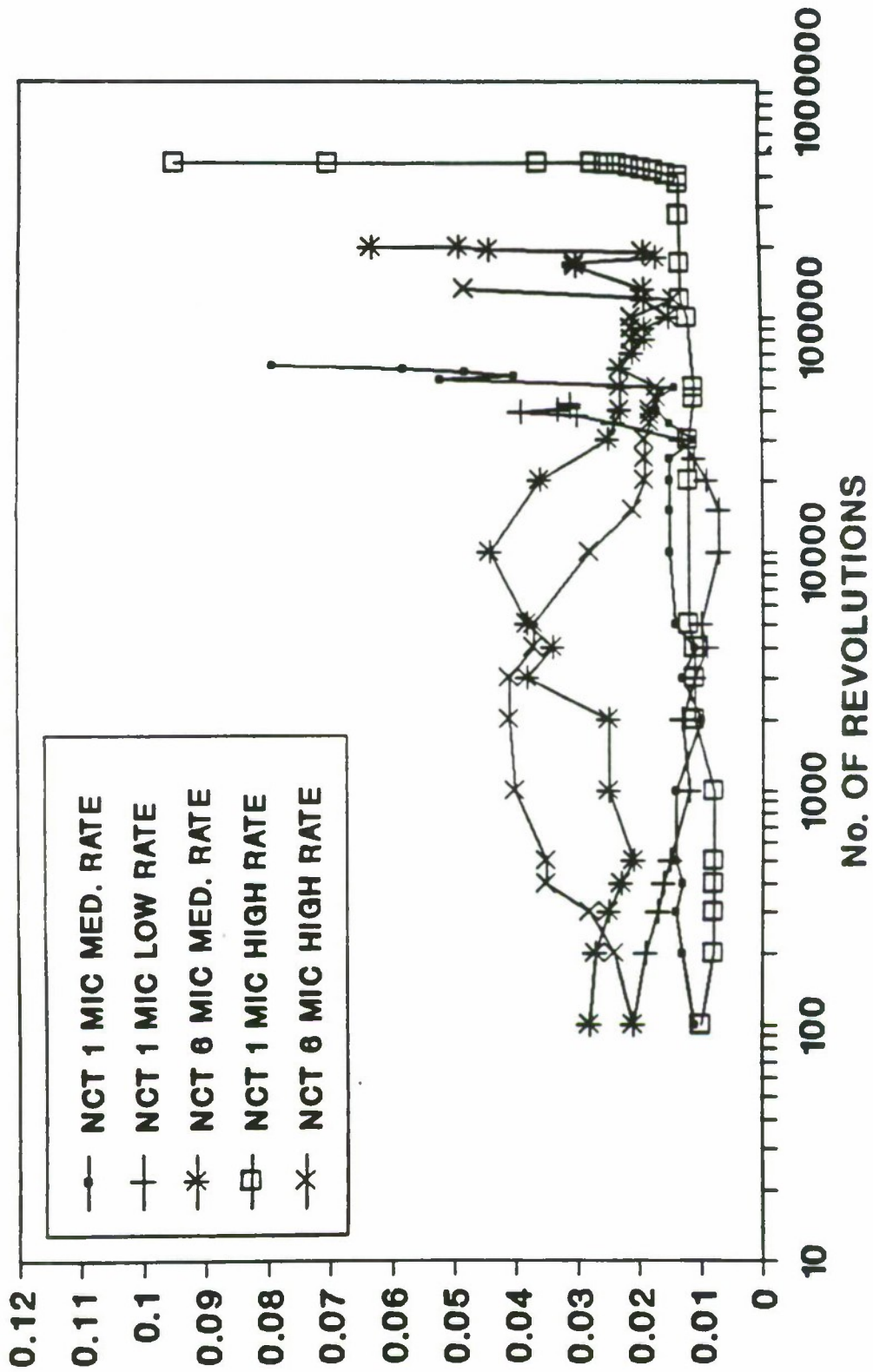
(1) based on \$1.77 / £

(2) based on \$1.65 / £



**PIN ON DISC TEST**  
**80 N LOAD, 400 RPM, < 5E-7 TORR**

**FRICTION COEFFICIENT**



**FIG 1**

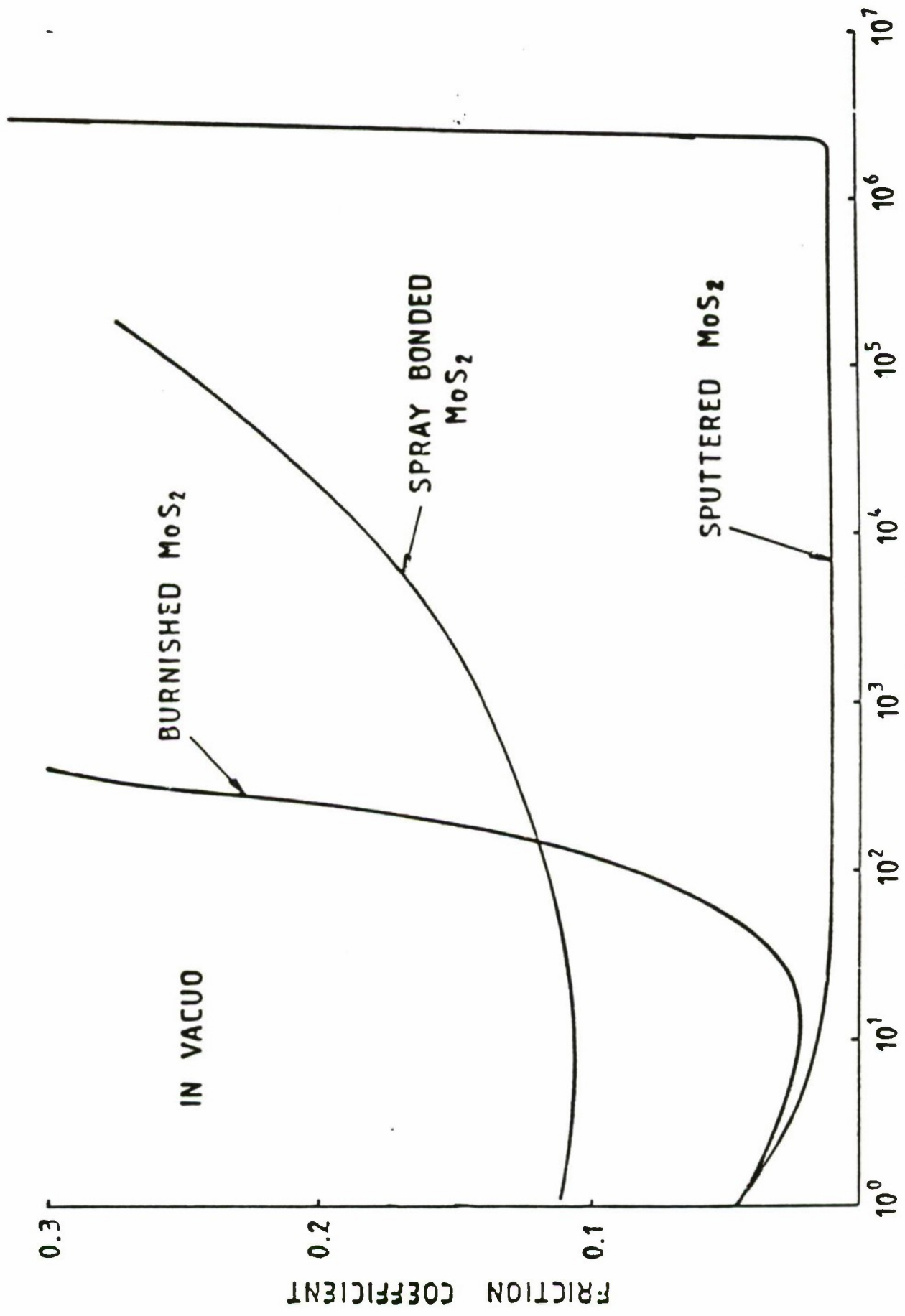
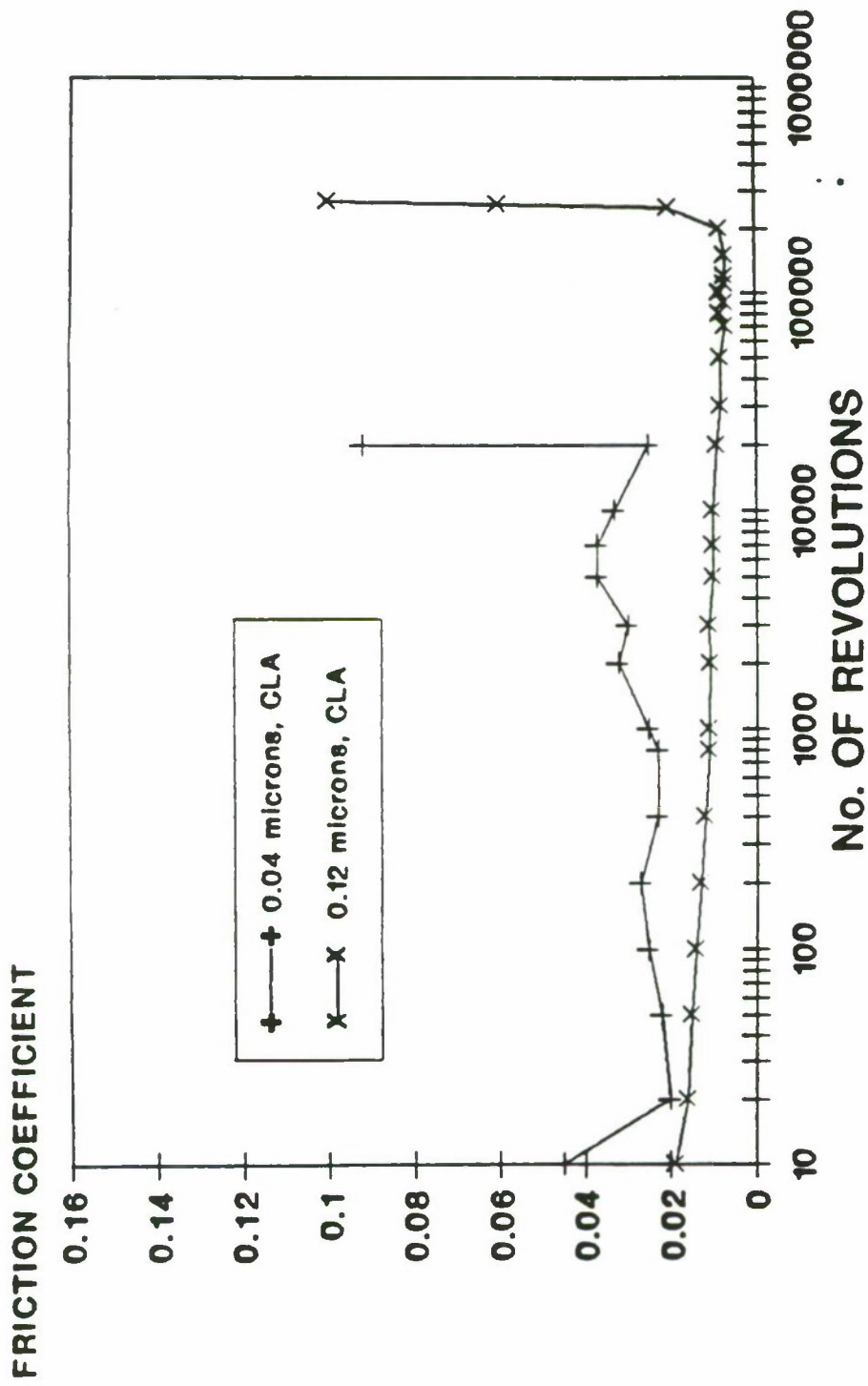


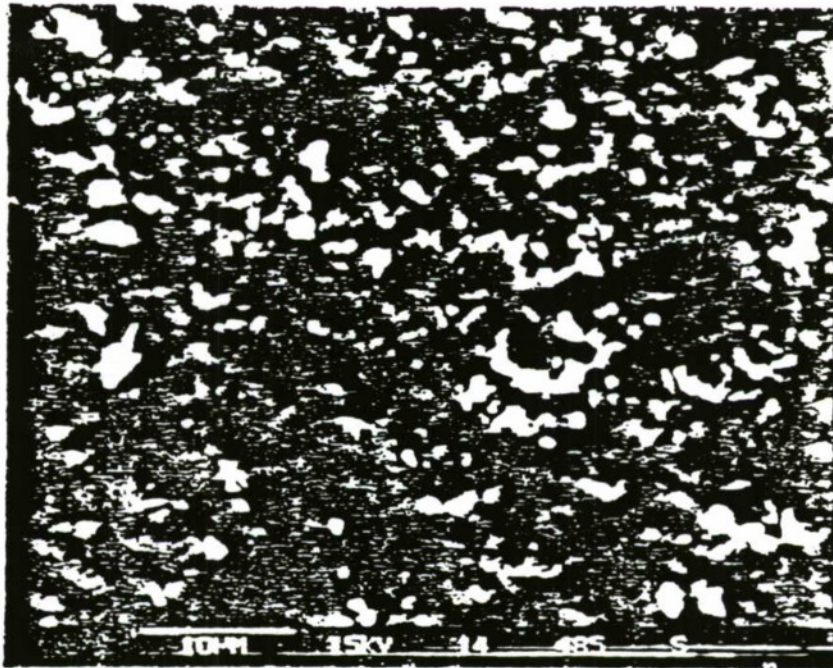
FIG. 2  
DISC REVOLUTIONS

FRICTION COEFFICIENTS OF MoS<sub>2</sub> FILMS DEPOSITED BY VARIOUS TECHNIQUES

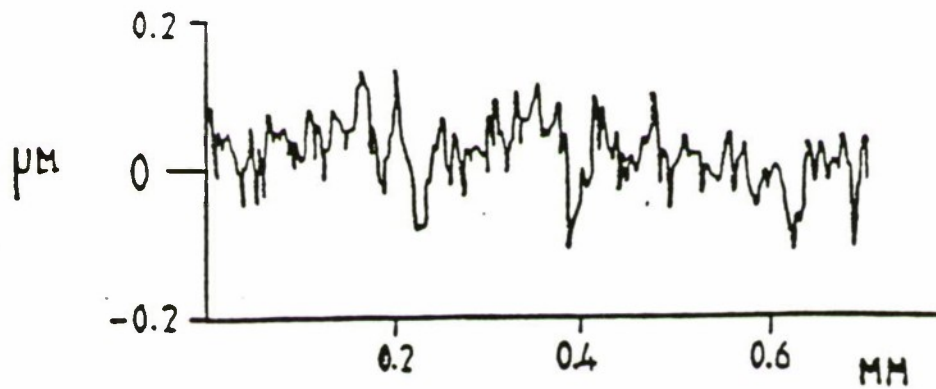


**FIG. 3 : EFFECT OF SURFACE ROUGHNESS ON FRICTION AND LIFE OF SPUTTERED MoS<sub>2</sub> FILM (SUBSTRATE: 52100 STEEL; HIGH VACUUM)**



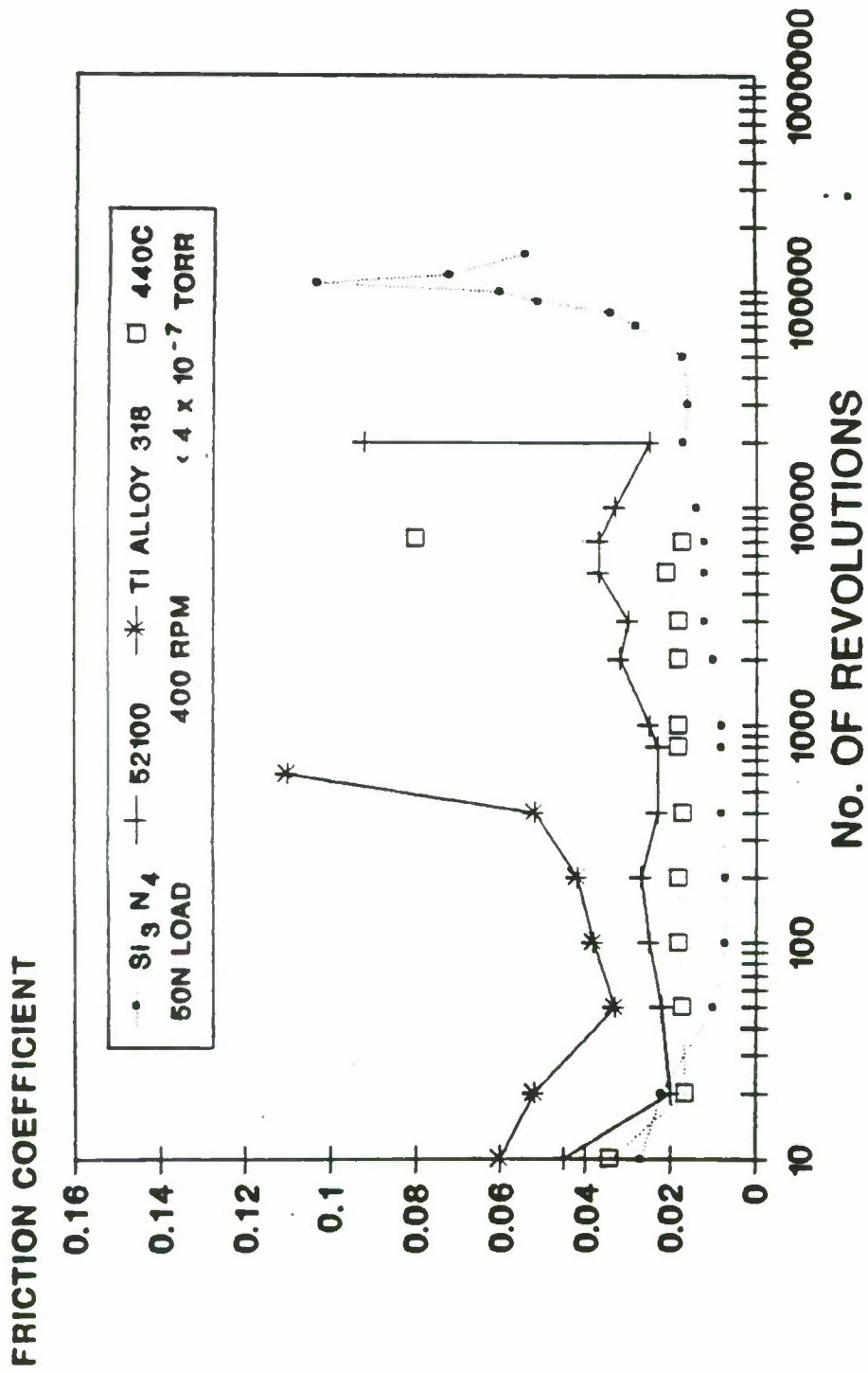


S.E.M. IMAGE OF SILICON NITRIDE THRUST RING WASHER



SURFACE PROFILE OF SILICON NITRIDE THRUST RING WASHER

FIG. 4



**FIG. 5 : PIN ON DISC TESTS  
MoS<sub>2</sub> ON VARIOUS SUBSTRATES**



SILICON NITRIDE



52100 STEEL



440C STEEL



318 TI ALLOY

S.E.M. IMAGES OF SPUTTER-DEPOSITED  $\text{MoS}_2$   
ON VARIOUS SUBSTRATES

FIG. 6



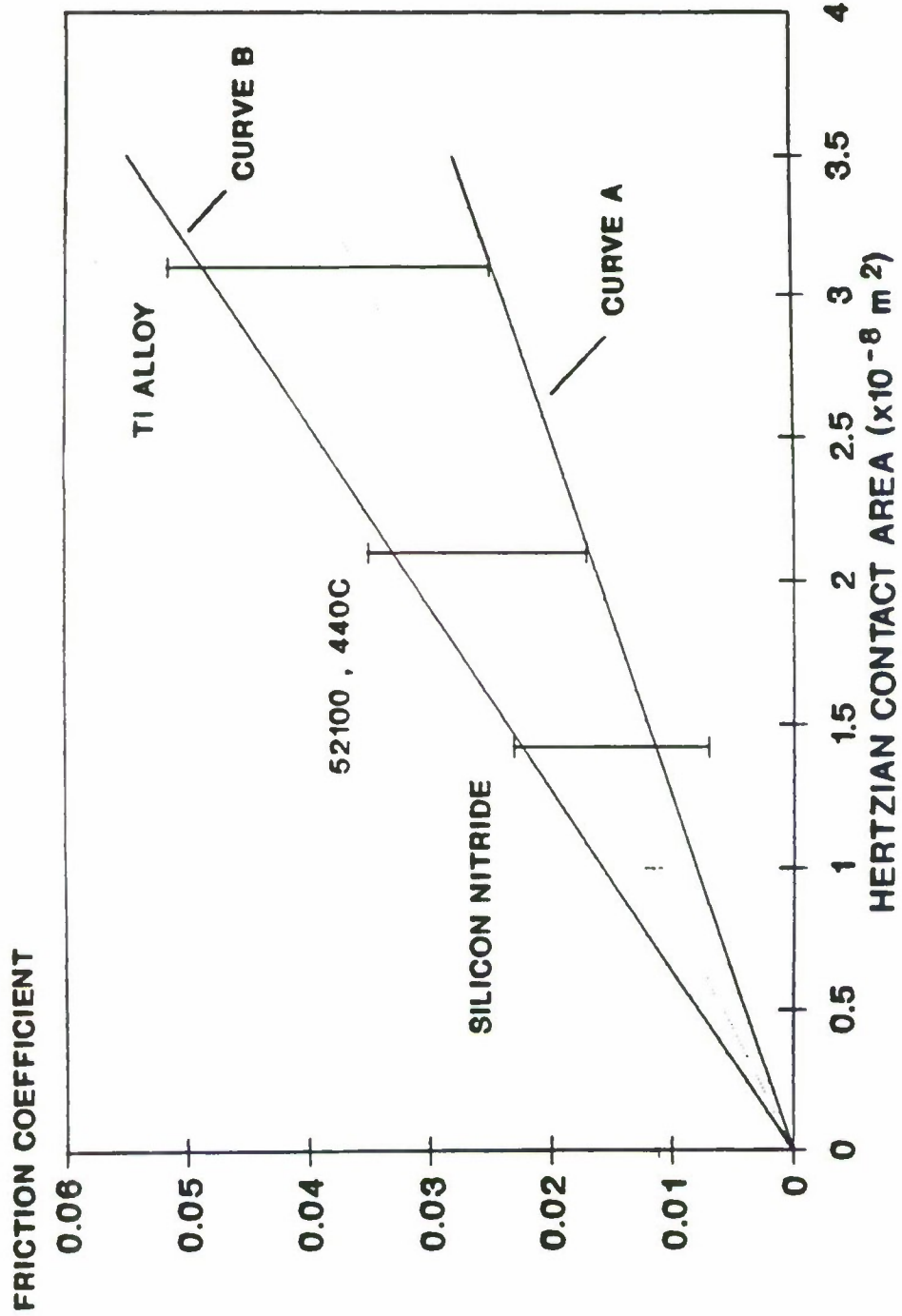


FIG. 7 : FRICTION COEFFICIENT VS. HERTZIAN CONTACT AREA

# MOSSI TEST RESULTS 1 MICRON FILMS

LOAD = 80 N      PRESSURE  $\times 5 \times 10^{-7}$  TORR      SPEED = 400 RPM

SAMPLE	FILM TYPE	THICKNESS (MICRONS)	RANGE OF FRICTION COEFFICIENT (PRIOR TO FAILURE)	TEST TERMINATED (REVS)
Ae AT 1B	MoS2	1.42	0.010-0.021	77,000
Ae HT 1B	MoS2	1.53	0.022-0.027	13,000
HOHMAN lot 9	MoS2	1.0-1.5	0.012-0.026	86,000
HOHMAN lot 13	MoS2 +Ni	1.0-1.5	0.014-0.025	113,000
NCT 1 LOW	MoS2	1.0	0.007-0.013	42,000
NCT 1 MEDIUM	MoS2	1.0	0.010-0.015	63,000
NCT 1 HIGH	MoS2	1.0	0.008-0.013	457,000

SUBSTRATE = 52-100 THRUST WASHER

**MOSSI TEST RESULTS  
6 MICRON FILMS**

**LOAD = 80 N      PRESSURE < 5x10<sup>-7</sup> TORR      SPEED = 400 RPM**

<b>SAMPLE</b>	<b>FILM TYPE</b>	<b>THICKNESS (MICRONS)</b>	<b>RANGE OF FRICTION COEFFICIENT (PRIOR TO FAILURE)</b>	<b>TEST TERMINATED (REVS)</b>
<b>Ae AT 6B</b>	<b>MoS2</b>	<b>6.17</b>	<b>0.015-0.031</b>	<b>45,000</b>
<b>Ae HT 6B</b>	<b>MoS2</b>	<b>7.22</b>	<b>0.020-0.030</b>	<b>42,000</b>
<b>HOHMAN lot 12</b>	<b>MoS2</b>	<b>6.0-6.5</b>	<b>0.015-0.032</b>	<b>156,000</b>
<b>HOHMAN lot 16</b>	<b>MoS2 +Ni</b>	<b>6.0-6.5</b>	<b>0.010-0.021</b>	<b>120,000</b>
<b>NCT 6 MEDIUM</b>	<b>MoS2</b>	<b>6.0</b>	<b>0.015-0.044</b>	<b>201,000</b>
<b>NCT 6 HIGH</b>	<b>MoS2</b>	<b>6.0</b>	<b>0.014-0.041</b>	<b>132,000</b>

**SUBSTRATE = 52-100 THRUST WASHER**

**TABLE 2**



**POWER / PRESSURE MATRIX**

**SPUTTERING POWER**

**0.4 KW    0.8 KW    1.2 KW**

<b>A</b>	<b>B</b>	<b>C</b>
<b>D</b>	<b>E</b>	<b>F</b>
<b>G</b>	<b>H</b>	<b>I</b>

**5**

**ARGON  
PRESSURE  
(MICRONS)**

**12.5**

**20**

**TABLE 3**

**DEPOSITION RATES DERIVED FROM  
THICKNESS CALIBRATIONS (Å / MIN)**

**SPUTTERING POWER**

**0.4 KW      0.8 KW      1.2 KW**

**ARGON  
PRESSURE  
(MICRONS) 5**

**20**

A	377	B 697	C 1110
D	410	E 940	F 1523
G	393	H 1013	I 993





**RESULTS OF TESTS ON 1 MICRON THICK  
FILMS FROM POWER / PRESSURE MATRIX**

**AVE. FRICTION  
COEFFICIENT**

**SPUTTERING POWER**

**0.4 KW    0.8 KW    1.2 KW**

**5**

**ARGON  
PRESSURE 12.5  
(MICRONS)**

**20**

A	0.011	B	0.021	C	0.020
D	0.012	E	0.013	F	0.013
G	0.015	H	0.014	I	0.020

**TABLE 6**