

REACTIVE STRUCTURE AND SMART ARMOR FOR ARMY'S FUTURE GROUND VEHICLES

David Chiyo and Suhasa Bangalore Kodandaramaiah
MKP Structural Design Associates, Inc.
Dexter, MI 48130

Karl Grosh and Zheng-Dong Ma*
University of Michigan
Ann Arbor, MI 48105

Basavaraju Raju and Farzad Rostam-Abadi
US Army TARDEC
Warren, MI 48397

ABSTRACT

An Reactive Structure Technology (RST) is being developed, where a Reactive Structure is defined as a new class of smart structure that can react to external excitations (such as a ballistic or blast impact) in a carefully designed way to counteract the hazardous loading or perform other desired tasks. Two prototypes of the reactive structure have been designed and fabricated for proving the concept of RST. The prototype basically consists of three integrated modules: 1) a structure with changeable configuration embedded with piezoelectric sensors for sensing the impact load; 2) an electronic control module capable of detecting external impacts and driving actuator to change the configuration of the structure; 3) a mechanism used to simulate the ballistic object. Also, an innovative sensor network using piezoelectric pillars has been developed, which can be used in smart armor for detecting the impact location in real time. The technologies developed in this research are expected to be used in applications of the protection of future ground vehicles.

1. INTRODUCTION

An innovative Reactive Structure Technology (RST) is being developed in this research, where a Reactive Structure is defined as a new class of smart structure that can react to external excitations (such as blast or ballistic impacts) in a carefully designed way using the energy pre-stored internally or from the external excitations to counteract the hazardous loading or perform other desired tasks.

Fig. 1 illustrates the concept whereby a reactive structure deflects an incoming projectile in order to protect the vehicle body. When a projectile hits the face plate (armor), the embedded sensors will feed the impact signal to a control unit, then actuators will be triggered to move the face plate (Fig. 1a). The movement of the face plate will deflect the projectile and significantly reduce the possibility of penetration in the back plate (Fig. 1b).

A common form of reactive armor is Explosive Reactive Armor (ERA)[1]. ERA tiles are usually used as add-on armor to the portions of an armored fighting

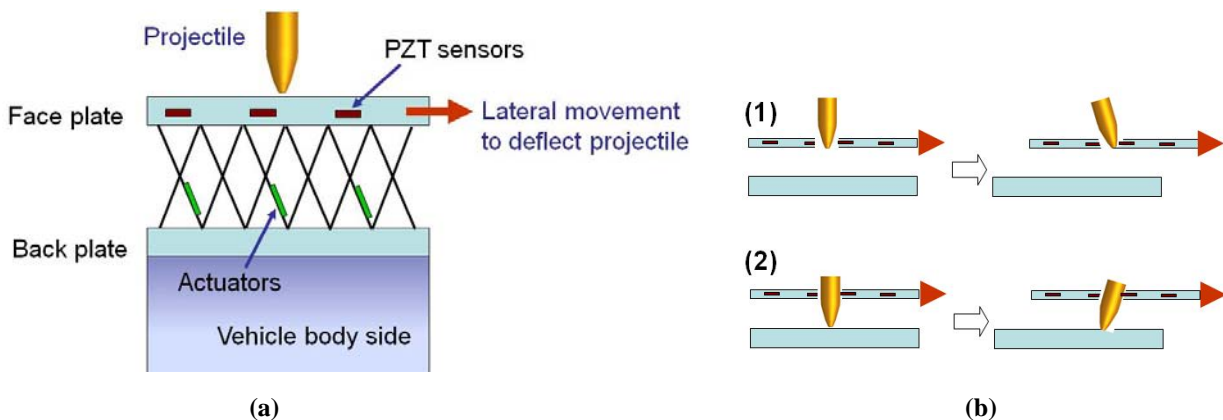

Figure 1 A concept of reactive structure for ballistic deflection

* Corresponding author; Email: mazd@mkpsd.com

Report Documentation Page

Form Approved
OMB No. 0704-0188

Public reporting burden for the collection of information is estimated to average 1 hour per response, including the time for reviewing instructions, searching existing data sources, gathering and maintaining the data needed, and completing and reviewing the collection of information. Send comments regarding this burden estimate or any other aspect of this collection of information, including suggestions for reducing this burden, to Washington Headquarters Services, Directorate for Information Operations and Reports, 1215 Jefferson Davis Highway, Suite 1204, Arlington VA 22202-4302. Respondents should be aware that notwithstanding any other provision of law, no person shall be subject to a penalty for failing to comply with a collection of information if it does not display a currently valid OMB control number.

1. REPORT DATE 11 AUG 2010	2. REPORT TYPE N/A	3. DATES COVERED -	
4. TITLE AND SUBTITLE Reactive Structure and Smart Armor for Aymy's Future Ground Vehicles		5a. CONTRACT NUMBER W56HZV-C-0532	
		5b. GRANT NUMBER	
		5c. PROGRAM ELEMENT NUMBER	
6. AUTHOR(S) David Chiyo; Suhasa Bangalore Kodandaramaiah; Karl Grosh; Zheng-Dong Ma; Basavaraju Raju; Farzad Rostam-Abadi		5d. PROJECT NUMBER	
		5e. TASK NUMBER	
		5f. WORK UNIT NUMBER	
7. PERFORMING ORGANIZATION NAME(S) AND ADDRESS(ES) MKP Structural Design Associates, Inc. Dexter, MI 48130 University of Michigan Ann Arbor, MI 48105 US Army RDECOM-TARDEC 6501 E 11 Mile Rd Warren, MI 48397-5000, USA		8. PERFORMING ORGANIZATION REPORT NUMBER 21173RC	
9. SPONSORING/MONITORING AGENCY NAME(S) AND ADDRESS(ES) US Army RDECOM-TARDEC 6501 E 11 Mile Rd Warren, MI 48397-5000, USA		10. SPONSOR/MONITOR'S ACRONYM(S) TACOM/TARDEC	
		11. SPONSOR/MONITOR'S REPORT NUMBER(S) 21173RC	
12. DISTRIBUTION/AVAILABILITY STATEMENT Approved for public release, distribution unlimited			
13. SUPPLEMENTARY NOTES Presented at the 27th Army Science conference (ASC), 29 November 2 December 2010 Orlando, Florida, USA, The original document contains color images.			
14. ABSTRACT An Reactive Structure Technology (RST) is being developed, where a Reactive Structure is defined as a new class of smart structure that can react to external excitations (such as a ballistic or blast impact) in a carefully designed way to counteract the hazardous loading or perform other desired tasks. Two prototypes of the reactive structure have been designed and fabricated for proving the concept of RST. The prototype basically consists of three integrated modules: 1) a structure with changeable configuration embedded with piezoelectric sensors for sensing the impact load; 2) an electronic control module capable of detecting external impacts and driving actuator to change the configuration of the structure; 3) a mechanism used to simulate the ballistic object. Also, an innovative sensor network using piezoelectric pillars has been developed, which can be used in smart armor for detecting the impact location in real time. The technologies developed in this research are expected to be used in applications of the protection of future ground vehicle			
15. SUBJECT TERMS			
16. SECURITY CLASSIFICATION OF:			17. LIMITATION OF ABSTRACT SAR
a. REPORT unclassified	b. ABSTRACT unclassified	c. THIS PAGE unclassified	
			18. NUMBER OF PAGES 8
			19a. NAME OF RESPONSIBLE PERSON

vehicle that are most likely to be hit. The use of ERA requires that the vehicle itself is fairly heavily armored. Another drawback to the use of ERA is the inherent danger to anybody near the vehicle. Although ERA plates are intended only to bulge following detonation, the combined energy of the ERA explosive, coupled with the kinetic or explosive energy of the projectile, frequently caused explosive fragmentation of the plate. The explosion of an ERA plate creates a significant amount of shrapnel, and bystanders are in grave danger of serious or fatal injury.

Another form of reactive armor is Non-Explosive Reactive Armor (NERA or NxRA). NERA uses passive material, such as rubber, sandwiched between two metal plates. The loads from NERA inflicted on the vehicle's structure are much smaller than ERA and therefore, can be applied to lighter vehicles. However, NERA is not as effective as ERA for protecting Kinetic Energy threats[2].

The reactive structure (armor) proposed in this research combines the advantage of both ERA and conventional NERA and eliminates their disadvantage. It consists of two main integrated modules: 1) a face metal plate embedded with impact sensors that is able to react the impact load and change the configuration using pre-stored potential energy or the energy from impact load; 2) an electronic control module capable of differentiating external impact loads by blasts and ballistic objects from normal vibrations during operation.

Two prototypes of the reactive structure have been designed and fabricated for proving the concept. In order to simulate the projectile object, a dropper mechanism

and a shooting device have also been developed. Experiments are carried out for the concept proof and the time response of the prototypes are discussed.

As a related technology of application of piezoelectric sensor, we have also developed an innovative sensor network that can be used to detect the location of impact load in real time in a very simple way and low cost. This technology may find a large market as applied to smart armor for the future ground combat vehicle.

2. PROTOTYPES OF REACTIVE STRUCTURE

2.1 Prototype I: Reactive Structure Using Pre-Stored Energy

2.1.1 The Structure of Prototype I

Fig. 2 shows pictures of the reactive Armor prototype I. It includes a main enclosure that houses the reactive structure. The system consists of three modules described as following.

1) The reactive structure module (Fig. 3) is made of a spring loaded four bar linkage. It is held in configuration A using a latch. In this position, the two springs are compressed and potential energy is stored in them. When the latch is unlocked, the springs uncoil, and the structure moves to configuration B under the spring force. Thus stored potential energy is used to bring out a configuration change. The substrate can be considered as the protected body, and the top plate represents the moving armor. The entry hole made in the top plate is for

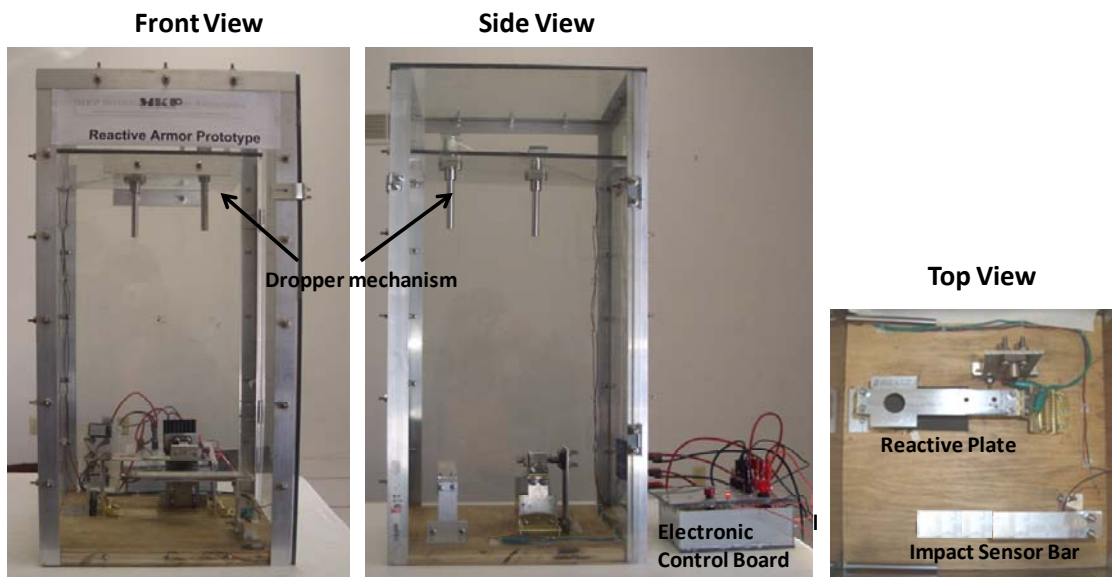

Figure 2 Prototype I developed for concept proof: Top view shows the layout of the device that allows two droppers to be used for testing and demonstration purpose

simulating the penetration by the ballistic object.

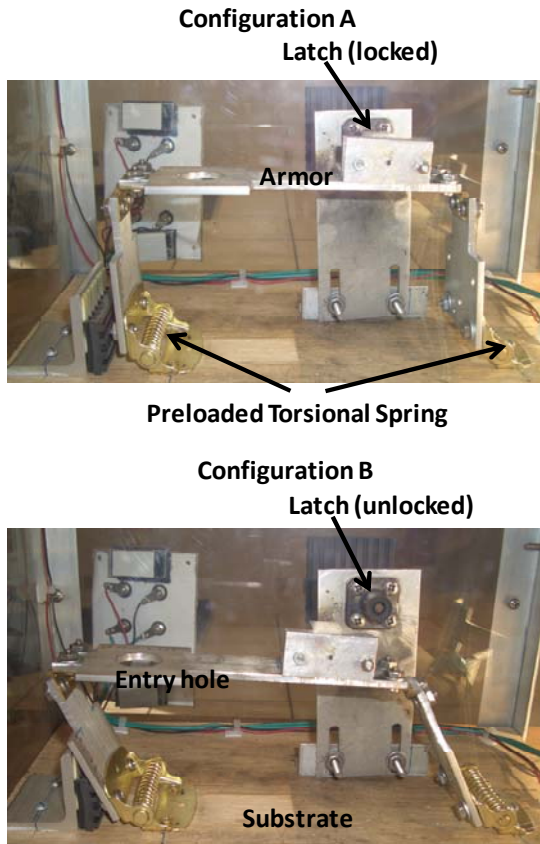

Figure 3 Four bar linkage reactive structure: Potential energy is stored in configuration A. When the latch is unlocked, the potential energy release results in the structure assuming configuration B

A pyrotechnic charge (E-match) is embedded in the latch as the actuator to release the latch. The pyrotechnic latch was chosen mainly because of its quick response and ready availability. Pyrotechnic latches are also far more reliable than mechanical fasteners and have been found in a number of space and aeronautical applications [3]. Further, the displacement of the actuator is directly related to the amount of pyrotechnic charge incorporated in it. This allows for easy scaling up of the device for full-scale application.

The principle of operation of the latch is shown in Fig. 4. It consists of a housing unit incorporating a hollow cylindrical chamber. The pyrotechnic charge is inserted in one end and sealed. The locking member of the latch is inserted in the other end of the housing chamber. The locking member is supported by a linear bearing and can move with a very small friction. When the E-match is detonated, the shock wave moves the locking member out of the chamber thus release the swivel arm. The response

time is dependent on two factors: the time taken to initiate the explosion, and the time duration of the explosion itself.

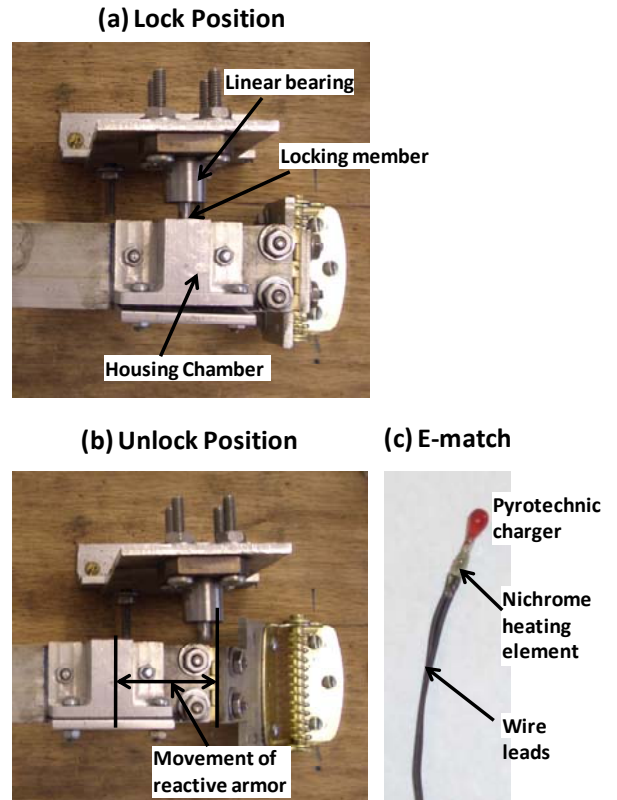

Figure 4 Principle of operation of pyrotechnic latch. (a) The latch in lock position. (b) The latch in unlock position. (c) E-match used as pyrotechnic charge

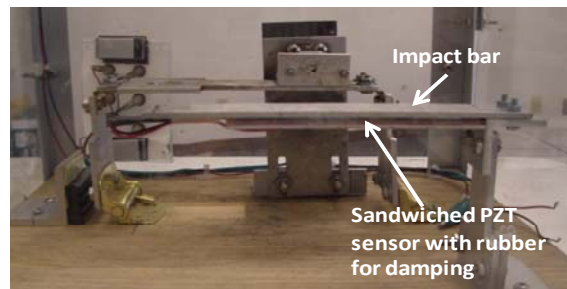

Figure 5 Impact bar embedded with a PZT sensor. A sandwich structure with a silicone rubber strip provides additional damping protection for the sensor

A piezoelectric sensor is embedded in a separated bar for detecting the ballistic impact. As shown in Fig. 5, A PZT bimorph strip is embedded within the two plates along with a thin rubber strip for damping. The main function of the impact bar is to provide the same level with the reactive structure so that two ballistic objects (described later) will strike on the impact bar and reactive structure

exactly at the same time – the former provides impact signal and the later simulates the penetration in the reactive structure.

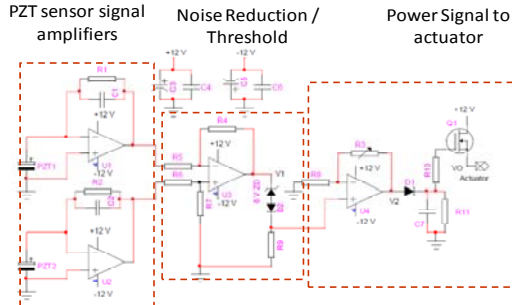

Figure 6 Circuit diagram of the Electronic Control Module: First stage is for amplifying the impact signal from the sensors, the second stage is to perform noise cancellation and threshold, and third stage is to supply the power actuating pyrotechnic charge

2) An electronic control module (ECM) is housed in a box as shown in Fig. 2. It includes a sensor signal amplifier, a noise reduction and thresholding circuit, and a power supply for the actuator. As shown in Fig. 6, the circuit is designed to take signals in from the two PZT sensors with one mounted on the substrate (PZT1) and the other mounted on the armor (PZT2) respectively. When the impact bar is deformed due to an impact, charges are generated in the PZT which is sent to the signal processing unit. In the first stage, the charges from PZT1 and PZT2 are amplified and converted to voltage signals using two follower OPAMPS. The voltage signals are then sent to difference OPAMP in the second stage where

triggered when PZT2 detects a large impact load. Once this signal reaches a particular threshold, the signal is sent to the third stage which consists of a RC network and a power MOSFET. The RC network generates a smooth waveform that triggers the power MOSFET into driving a suitable current to the actuator.

In the current prototype, the PZT mounted on the substrate has been eliminated since there is no considerable noise existing in the test environment.

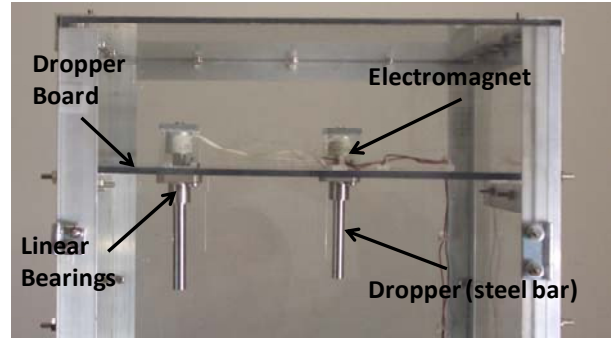

Figure 7 Dropper release mechanism used to simulate the ballistic objects: two droppers fall simultaneously by release electromagnets at the same time

3) A dropper mechanism is used to synchronously release two weights onto the reactive structure and the impact sensing bar. As shown in Fig. 7, the dropper release mechanism consists of two electromagnets wired in parallel and operated by a switch located in the electronic control unit. Two droppers, made of steel shaft, are used to simulate the projectiles: one hitting the impact bar provides impact load for sensing; another one hitting on

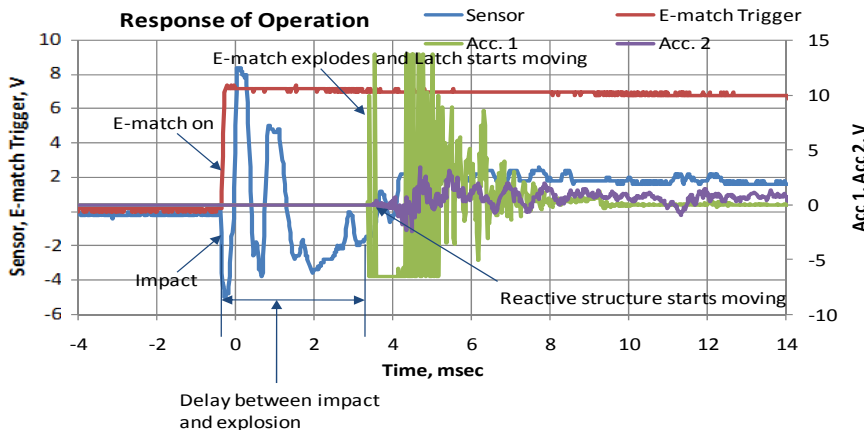

Figure 8 Time response of Prototype I: only 3.5 msec. delay exists between the impact signal and release of the pyrotechnic latch

the two signals are compared. Since both PZT1 and PZT2 move simultaneously during normal vibration condition, even considerable large vibration on the substrate cannot trigger the sensor output. The sensor output will only be

the reactive structure simulates the penetration and the deflection. The dropper board is located at a height of 500 mm from the impact bar and top plate of the reactive

structure. Thus the velocity of the droppers at the time of impact is about 3 m/s.

2.1.2 Experiment Results and Discussion

Experiments were carried out to characterize the time response of the reactive armor prototype. Four signals are simultaneously measured: a) impact signal from sensor, b) voltage for actuating E-match, c) acceleration of the moving member of the latch (accelerometer 1), and d) acceleration of the reactive structure (accelerometer 2). This measurement allows us to characterize the times delays at various stages of operation. Fig. 8 illustrates a typical example of the measurement results. It is seen that voltage signal for detonating the E-match is generated almost at the same time with the detection of impact signal, but latch (Acc. 1) starts to move after at about 3.5 msec. The reactive structure starts to move almost without delay after the latch is released. The 3.5 msec delay from impact signal to the release of the latch is considered being taken by the heating up and explosion of the E-match.

Using a high speed video camera, the action of the reactive structure on an incoming projectile was verified (see Fig. 9). A movie of the motion of droppers (projectile) and reactive structure was taken at the rate of 1000 fps (frames per second). Fig. 9 shows a sequential montage of the images captured from the movie.

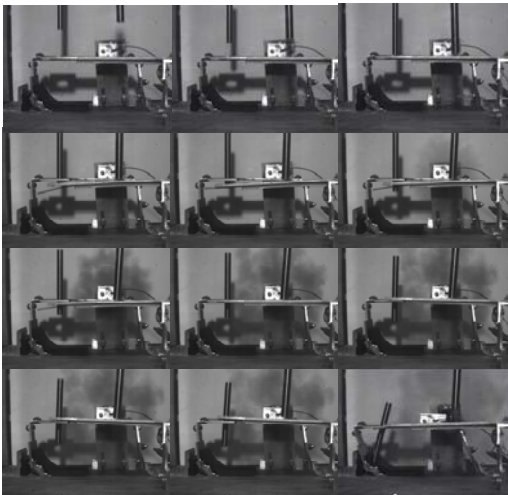

Figure 9 Images taken using a high speed camera confirmed the operation of the Prototype I and the deflection of projectile

2.2 Prototype II: Reactive Structure Using External Energy of Impact Load

2.2.1 The Structure of Prototype II

The schematic of prototype II is shown in the Fig. 10. The reactive armor is supported by the arms and rotating hinges. One of hinge at the right end is locked by a pyrotechnic latch. When the projectile hits the reactive armor, the piezoelectric sensor embedded in the armor detects the impact signal and an E-match installed in the pyrotechnic latch will be detonated. There is a slot on the armor for the purpose simulating the penetration of the projectile. The width of the slot is designed a little narrower than the diameter of the projectile body so that only the projectile's tip can enter the slot but not the projectile body. Once the pyrotechnic latch is released by the detonation of E-match, the reactive armor moves in the direction shown in the figure under the propulsive force of the projectile. In the case of blast impact, the wave of blast pressure plays the role to move the reactive armor. As shown in the lower illustration of Fig. 10, the projectile will be deflected by the movement of the armor.

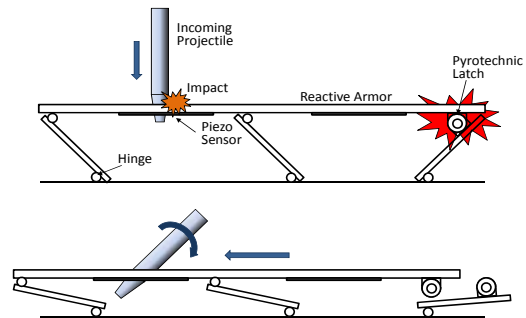

Figure 10 Prototype II: Upper illustration shows the static structure and lower one the motion of the reactive structure and the deflection of the projectile

Fig. 11 shows a picture of the entire test setup of prototype II and the Electronic Control Box integrated with a power supply. A frame is built for housing the reactive armor and projectile device. The height of the mount of the projectile can be adjusted with the maximum of 700 mm. A close-up of the reactive armor is shown in Fig. 12. The pyrotechnic latch was improved in a compact dimension that allows it to be embedded in the reactive structure. Three potentiometers are built in: potentiometer 1, a sliding potentiometer, is located right backside of the pyrotechnic latch which detects the release of the latch; rotating potentiometer 2 is embedded in the hinge of the center support arm which measures the rotating angle of the hinge shaft; slid potential meter 3 is located on the left end (in front view) which directly measures the linear motion of the armor.

A close-up of the projectile device is shown in Fig. 13. The projectile can be simulated in three types: (1) freefalling projectile (dropper), (2) freefalling projectile with an additional weight, and (3) projectile with an ejecting device using E-match explosion.

Test Setup of Reactive Armor

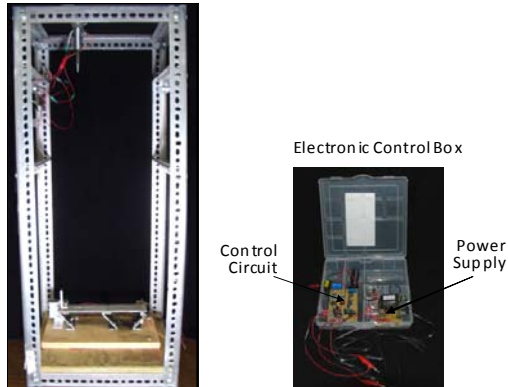

Figure 11 Prototype II and Electronic Control Module integrated with a power supply

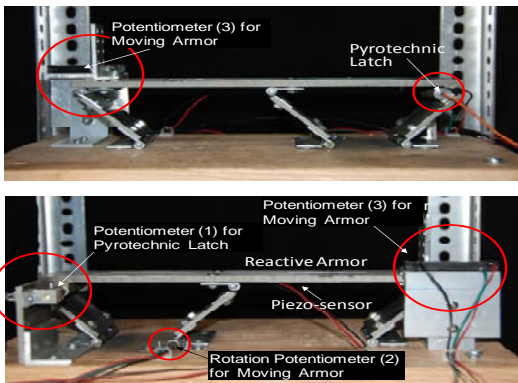

Figure 12 Close-up of Prototype II: Three potentiometers are built in for measuring the motion of the structure.

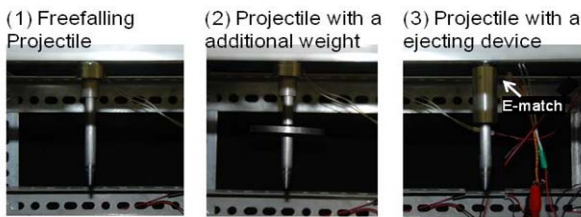

Figure 13 Close-up of projectile mechanism

2.2.2 Experiment Results and Discussion

Figs. 14 to 16 show measurement results of the time response of the reactive armor in the three different test configurations: Fig. 14 shows the results for a freefalling projectile, Fig. 15 shows the results for a freefalling projectile with a additional weight (300g), and Fig. 16 the ejected projectile (falling faster than freefall). In Figs. 14-16 “Sensor” denotes the voltage signal detected by the piezoelectric sensor, “Actuation” the voltage signal acting on the E-match, “Latch” the voltage signal measured from potentiometer 1 that corresponds to the moving distance

of the latch, and the “Armor” the voltage signal from potentiometer 3 corresponds to the moving distance of the armor (potentiometer is not used here).

Comparing the voltage signals of the sensor and the actuation voltage gives us the delay between the impact and the actuation signal induced by the circuit, the sensor voltage and potentiometer 1 gives the time taken for the E-match explosion to take place and finally, comparing signals of the sensor and the potentiometer gives the time delay between impact and response of the reactive armor.

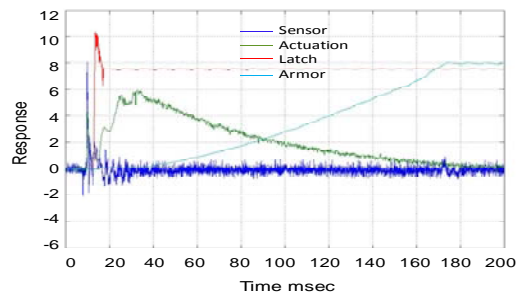

Figure 14 Time response of Prototype II in the test mode of freefalling projectile

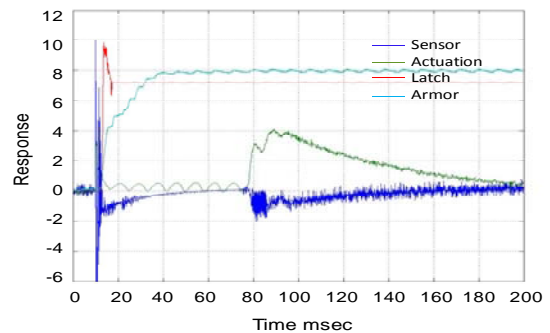

Figure 15 Time response of Prototype II in the test mode of freefalling projectile with an additional weight

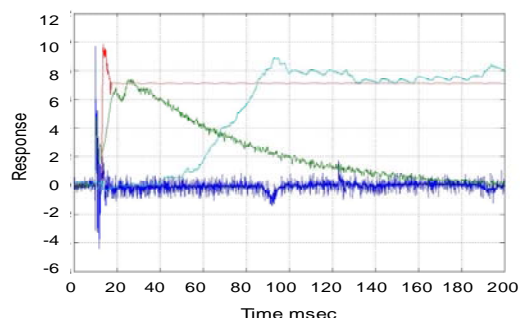

Figure 16 Time response of Prototype II in the test mode of ejected projectile

From Figs. 14 to 16 it is seen that the delay of the actuation signal from the impact signal is less than 0.3 msec for all test modes. The delay of the response of the

Figs. 20 to 22 show examples of the output data of Lin 1 through Lin 3 when the impact load acts from point 2 to point 4. For observing the data in detail, the acquired data are scaled up. It is seen from Figures 20 to 22 that the channel causing the trigger always coincides with the line that is the closest to the impact point. This fact allows us to know the approximate the impact point in a very simple way without any calculation.

For increasing the accuracy of the location detection, there are two methods can be considered. One is increase the density of the distribution of the sensor lines; another is to check the signals of the adjacent lines of triggering line. Table 1 shows a algorithm that can determin a more accurate impact location. In the tabel Trig 2 means sencond trigger (set as 0.5V). It is figured out from the all measurement results from point 1 to 9.

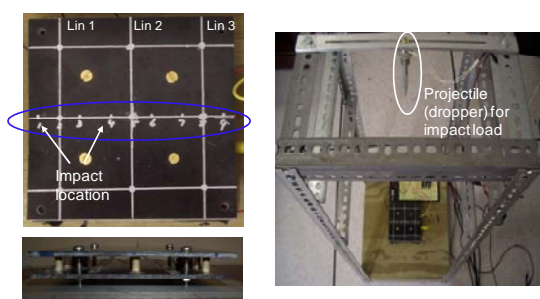

Figure 19 Armor embedded with a single layer sensor network and test setup for detection of the impact location

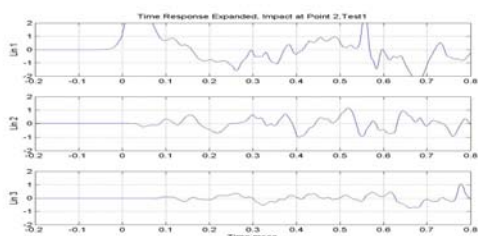

Figure 20 Sensor network's time signal: impact at point 2

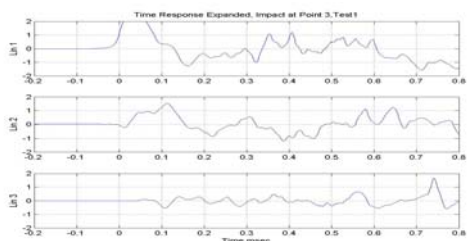

Figure 21 Sensor network's time signal: impact at point 3

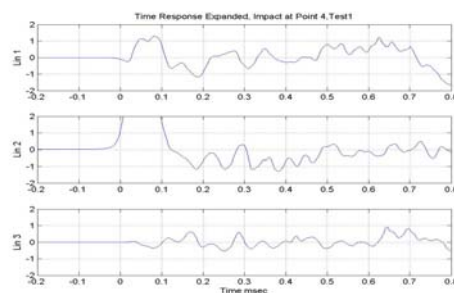

Figure 22 Sensor network's time signal: impact at point 4

Table 1 A algorithm that provides more accurate detection of the impact point

Impact point	Signal Characteristics			Detected Impact area
	Lin 1	Lin 2	Lin 3	
1	Trig			Lin 1
2	Trig			
3	Trig			
4	Trig 2	Trig		Lin 2 left
5		Trig		Lin 2
6		Trig	Trig 2	Lin 2 right
7			Trig	Lin 3
8			Trig	
9			Trig	

CONCLUSIONS

Fundamental elements in an innovative reactive structure technology have been laid out and studied with a focus on ballistic protection which demonstrate the feasibility as well as the some future work needed to realize the objective of this approach. It is seen that with further development of the new technology, it is possible to utilize the energy from a hazardous loading to counteract the hazardous loading itself. Also an innovative approach using a sensor network for real time detection of impact location has been developed, which can be potentially used to develop a smart armor for future ground vehicle.

ACKNOWLEDGEMENT

This research is supported by the U.S. Army TARDEC under contract No: W56H2V-09-C-0532 through MKP Structural Design Associates, Inc.

REFERENCE

- http://en.wikipedia.org/wiki/Reactive_armour
- <http://defense-update.com/features/du-1-04/reactive-armor.htm>
- Lee, H. S., "Unsteady Gas-dynamics Effects in Pyrotechnic Actuators," J. Spacecrafts and Rockets, Vol. 41, No. 5, pp. 877-886