



*inspired by ideas...driven by markets*

# Smart Sensor Network for Aircraft Corrosion Monitoring

2010 U.S. Army Corrosion Summit  
February 9-11, Huntsville, AL

Fritz Friedersdorf, Jeff Demo and Josh Averett

This material is based upon work supported by the United States Navy under contract Nos. N68335-09-C-0099 & N68335-09-C-0107. Any opinions, findings and conclusions or recommendations expressed in this material are those of the authors(s) and do not necessarily reflect the views of the United States Navy.

# Report Documentation Page

Form Approved  
OMB No. 0704-0188

Public reporting burden for the collection of information is estimated to average 1 hour per response, including the time for reviewing instructions, searching existing data sources, gathering and maintaining the data needed, and completing and reviewing the collection of information. Send comments regarding this burden estimate or any other aspect of this collection of information, including suggestions for reducing this burden, to Washington Headquarters Services, Directorate for Information Operations and Reports, 1215 Jefferson Davis Highway, Suite 1204, Arlington VA 22202-4302. Respondents should be aware that notwithstanding any other provision of law, no person shall be subject to a penalty for failing to comply with a collection of information if it does not display a currently valid OMB control number.

1. REPORT DATE <b>FEB 2010</b>		2. REPORT TYPE		3. DATES COVERED <b>00-00-2010 to 00-00-2010</b>	
4. TITLE AND SUBTITLE <b>Smart Sensor Network for Aircraft Corrosion Monitoring</b>				5a. CONTRACT NUMBER	
				5b. GRANT NUMBER	
				5c. PROGRAM ELEMENT NUMBER	
6. AUTHOR(S)				5d. PROJECT NUMBER	
				5e. TASK NUMBER	
				5f. WORK UNIT NUMBER	
7. PERFORMING ORGANIZATION NAME(S) AND ADDRESS(ES) <b>Luna Innovations Incorporated,1 Riverside Circle, Suite 400,Roanoke,VA,24016</b>				8. PERFORMING ORGANIZATION REPORT NUMBER	
9. SPONSORING/MONITORING AGENCY NAME(S) AND ADDRESS(ES)				10. SPONSOR/MONITOR'S ACRONYM(S)	
				11. SPONSOR/MONITOR'S REPORT NUMBER(S)	
12. DISTRIBUTION/AVAILABILITY STATEMENT <b>Approved for public release; distribution unlimited</b>					
13. SUPPLEMENTARY NOTES <b>U.S. Government or Federal Rights License</b>					
14. ABSTRACT					
15. SUBJECT TERMS					
16. SECURITY CLASSIFICATION OF:			17. LIMITATION OF ABSTRACT	18. NUMBER OF PAGES	19a. NAME OF RESPONSIBLE PERSON
a. REPORT	b. ABSTRACT	c. THIS PAGE			
<b>unclassified</b>	<b>unclassified</b>	<b>unclassified</b>	<b>Same as Report (SAR)</b>	<b>22</b>	

# Outline

- **Smart Sensor Network**
  - *Needs and technology overview*
- **Network Elements**
  - *Hub, Network capable application processor (NCAP)*
  - *Node, Smart transducer interface module (STIM)*
- **Corrosion Sensing and Measurements**
  - *Corrosion rate*
  - *Cumulative corrosion*
  - *Environmental parameters*



# Issue / Need

- Aircraft corrosion is a leading maintenance cost driver that impacts readiness and safety
  - *Costs increase as the fleet ages*
- A corrosion monitoring system for current and future weapon systems is need to:
  - *Identify, track and locate environmental conditions that cause corrosion damage*
  - *Improve inspection efficiency by identifying only those aircraft and systems that require attention*
  - *Reduce maintenance costs through early detection*
  - *Maximize operational availability*



# Sensor Node and Hub



## ■ Sensor Hub

- Centralized wired or wireless data hub provides communications between user network and sensor network
- Embedded processing for on-board data reduction
- Ultra-low power, for use with energy harvesting technologies
- Open architecture



## ■ Sensor Nodes

- Distributed sensor nodes for corrosion hotspot monitoring
- Wired or wireless interface to sensor hub
- Flexible modular design can support a wide variety of sensors
- Integrated sensor elements for corrosivity and corrosion measurements
- IEEE-1451 compliant for plug-and-play simplicity

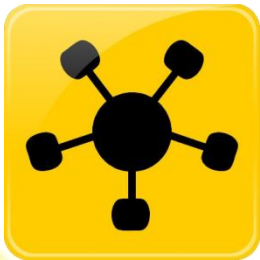

# Vehicle Health Management

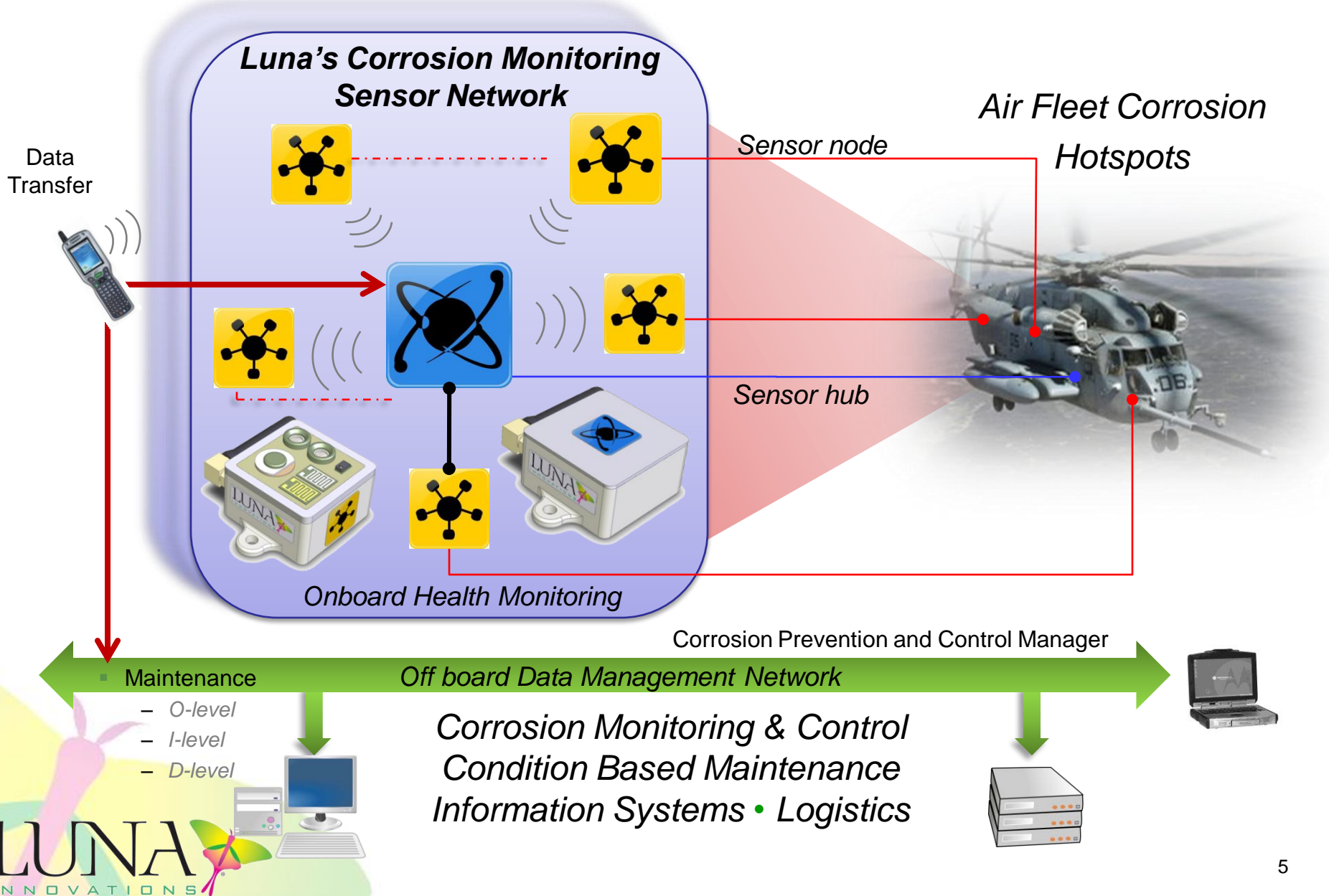

# Sensor Node and Hub

- IEEE-1451 standard defines sensor node and hub
  - Both sensor node and hub are based off common hardware
  - Sensor hub interfaces with user network and sensor nodes
    - Wired or wireless communications with other system elements
  - Sensor node interfaces with transducer elements and hub
    - Communications between hub and node can be wired or wireless
    - Node contains transducer electronic data sheets (TEDS)
      - Plug-and-play capabilities between sensor nodes and hub elements

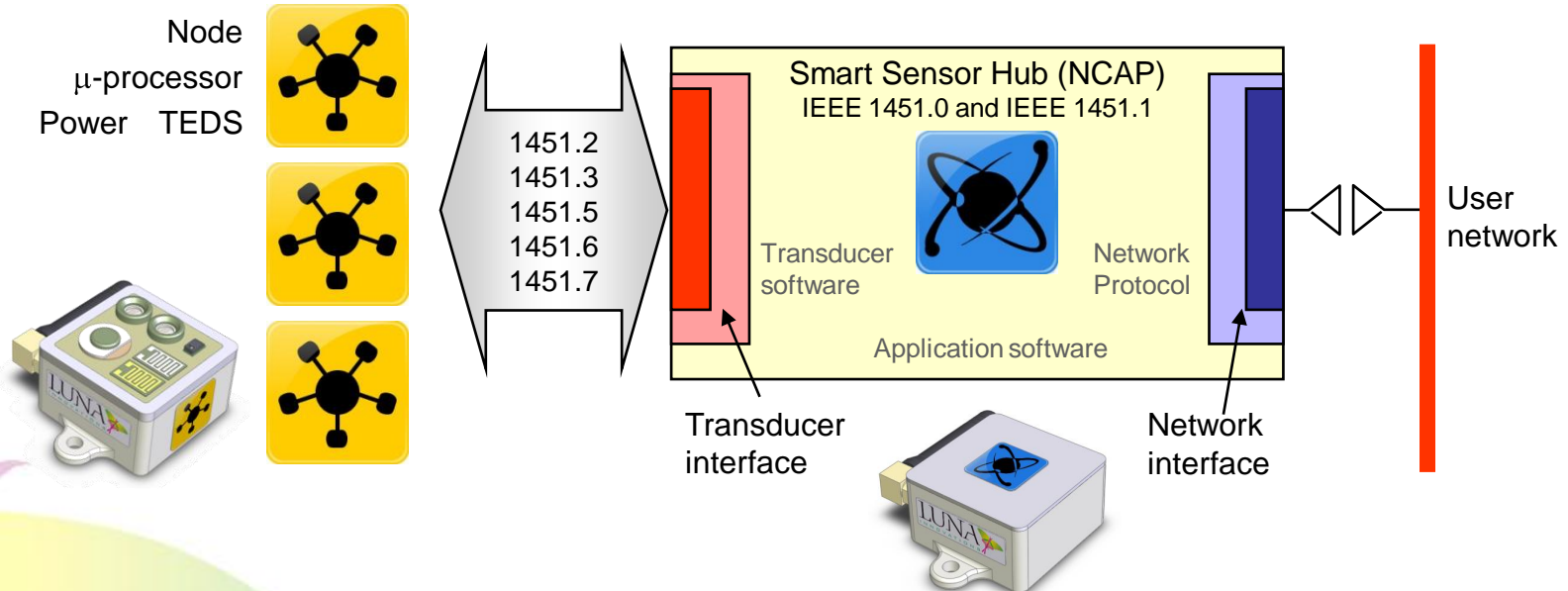



# Modular Sensor Node and Hub

- Modular design allows for ease of development and application customization
- Design consists of three main hardware elements: base board, communications board, and analog board
  - *Base board is common to sensor node and hub*
    - microcontroller, power regulation, system memory, real time clock
  - *Communications board can vary as needed between sensor node and hub*
    - Wireless communications, USB or Ethernet controller, or UART pass-through
  - *Analog board is unique to the sensor node*
    - Analog board can be used to meet requirements for a wide range of transducer elements
    - Provides transducer excitation and signal conditioning
    - Direct access to all 8 microcontroller ADC channels,
    - Could incorporate multiplexers if additional transducers are required

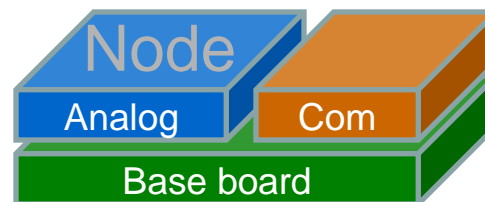
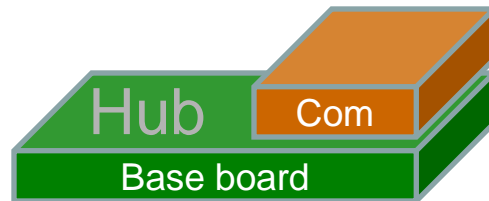
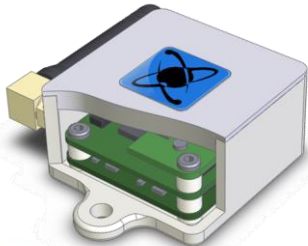



# Corrosion Sensing and Monitoring

- Existing corrosion sensing technologies can be divided into three categories:
  - *Instantaneous corrosion rate measurements*
  - *Cumulative corrosion and material loss measurements*
  - *Environmental measurements*
- A suite of sensors offers the most robust measurements for building diagnostic algorithms and automating sensor validation routines
  - *Corrosion damage can be measured using surrogate samples, or inferred with environmental data*



# Sensor Development

- Miniature, light weight sensor suite can be used to measure corrosive severity of operational environments
- The sensor suite permits instrumentation of critical components, inaccessible areas, and “corrosion hotspots”
- Monitors multiple environmental parameters and corrosivity
  - $i_{corr}$ ,  $E_{ocp}$ ,  $ER$ ,  $Inductance$ ,  $RH$ ,  $T_{air}$ ,  $T_{surf}$ ,  $TOW$ ,  $[Cl^-]$
- Supports data fusion for improved state awareness and reduced uncertainty in estimating corrosion damage

Individual Sensing Elements

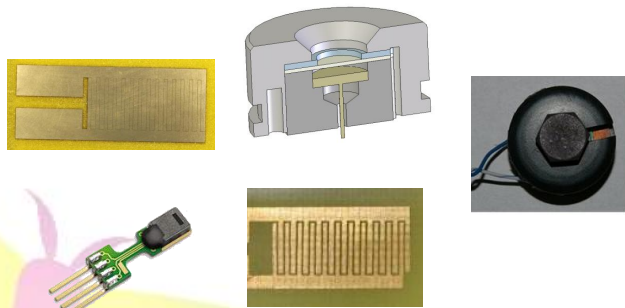

Sensor Suite



Sensor Node



# Instantaneous Measurements

- Instantaneous measurements are used to characterize corrosivity at any given time
  - *A measure of cumulative damage can be obtained by integrating periodic corrosion rate measurements*

Sensor	Comments
Corrosion rate	Low power and low frequency excitations. Provides a measurement of $R_p$ for calculating $i_{corr}$
Corrosion potential	Passive device. Requires high impedance input circuitry. Electrochemical measurement of $E_{ocp}$

AA7075-T6 interdigitated electrode

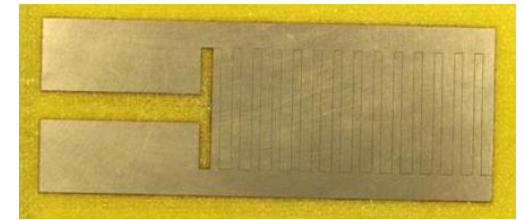

Ag/AgCl electrode

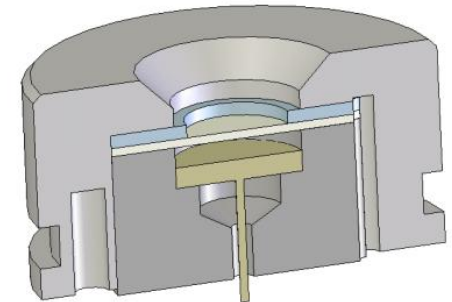

# Cumulative Corrosion Sensors

- Cumulative corrosion sensors measure the total damage to a sensing element
  - *The total amount of damage can be determined at any time*
  - *Corrosion rate from the change in state for a given time interval*

Sensor	Comments
Inductive/Eddy Current Sensor	Requires low power AC excitation. Inductive coupling between sensor and surrogate sample provides measure of material loss. Sensor can be used for localized corrosion of an alloy.
Electrical Resistance Probe	Low power Wheatstone bridge measurement technique. Resistive changes dependent on material loss. Typically a copper sensor for generalized corrosion.

Inductance sensor

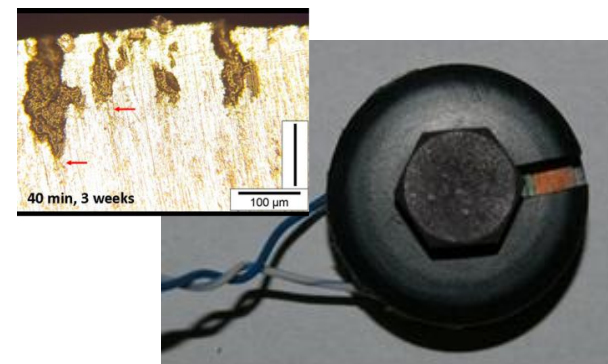

ER probe

Rohrback Cosasco Systems  
(Model 610-TF50)

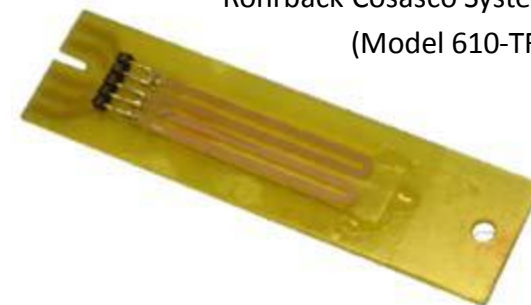

# Environmental Sensors

- Environmental sensors are used to measure corrosivity
  - *Atmospheric conditions or microclimates within a structure*

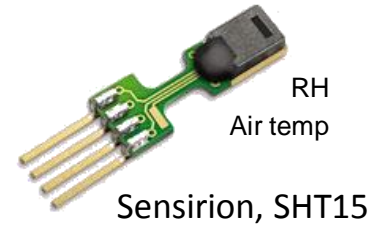

Au/Au interdigitated

Sensor Technology	Specifications & Comments
Time of Wetness (TOW) / Surface conductivity	Gold-gold interdigitated electrode design. Requires low power, low voltage AC excitation source.
Chloride Sensor	Passive device. Requires high impedance input circuitry.
Relative Humidity / Air Temperature	Miniature, digital module +/-2.0% RH accuracy, +/-0.3% Temp accuracy. Average power consumption of 150µW.
Surface Temperature	Platinum RTD with accuracies to +/-0.15°C @ 0° (Class A RTD). Sensors can be driven with low power constant current circuitry.

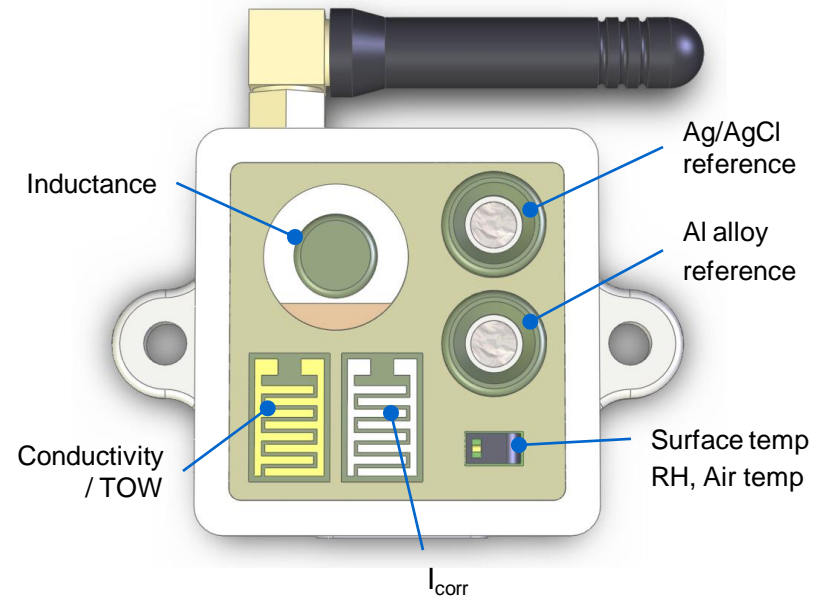

# Reference Electrode

- Reference electrodes are used to measure the corrosion potential ( $E_{ocp}$ ) for a given alloy and environment
  - For a given alloy,  $E_{ocp}$  can be used to predict pitting or uniform corrosion
  - AA2024-T3 or AA7075-T6 working electrode
- Reference electrode can also be used to measure chloride concentration (Nernst Equation)
  - Pure silver working electrode for measuring  $[Cl^-]$

$$E = E^{\circ} - \frac{RT}{F} \ln a_{Cl^-}$$

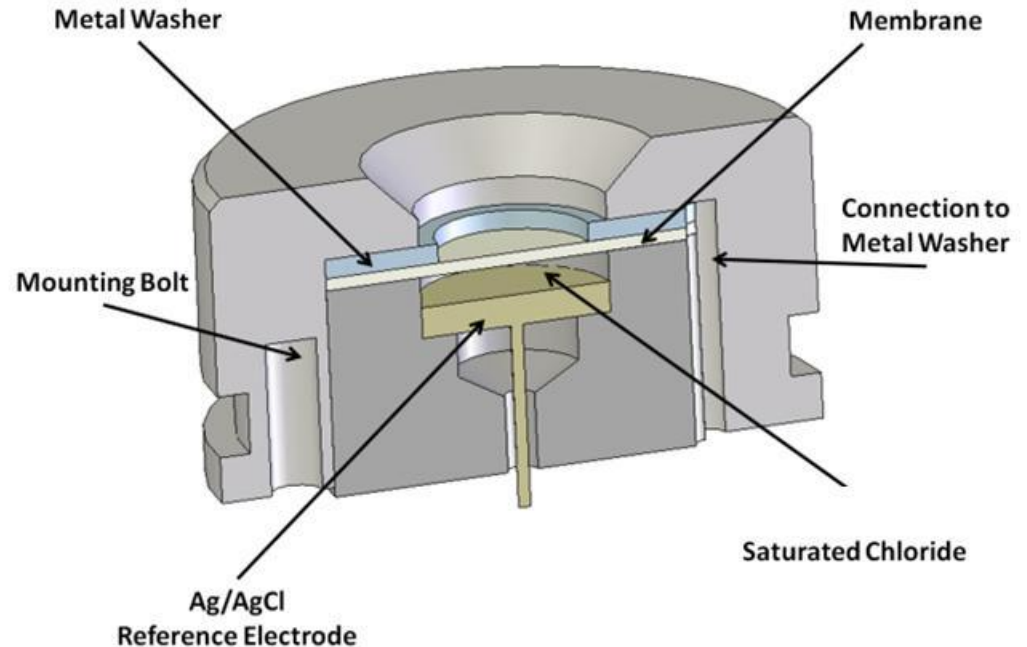



# Reference Electrode

- Reference electrode testing for stability of potential measurements
  - *0.01, 0.1, 0.5, and 1. M NaCl solutions in 90% RH*
  - *Immersion tests at 1.0 and 0.1 M NaCl*
  - *long term potential is unaffected by chloride concentration*

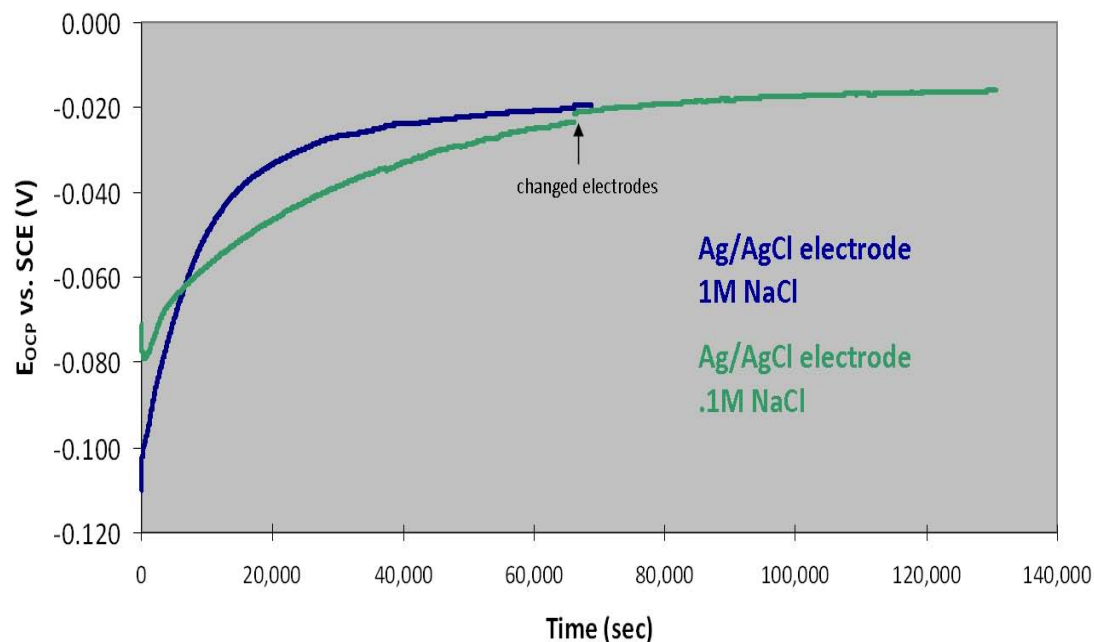

# Interdigitated Electrodes

- Interdigitated electrodes can be used to measure polarization resistance ( $R_p$ ) and solution resistance ( $R_s$ )
  - Corrosion rate ( $i_{corr}$ ) can be determined from  $R_p$
  - $R_s$  is dependent on salt concentration
  - $R_s$  can be used to measure time of wetness

Interdigitated electrode  
(AA7075 & AA2024)

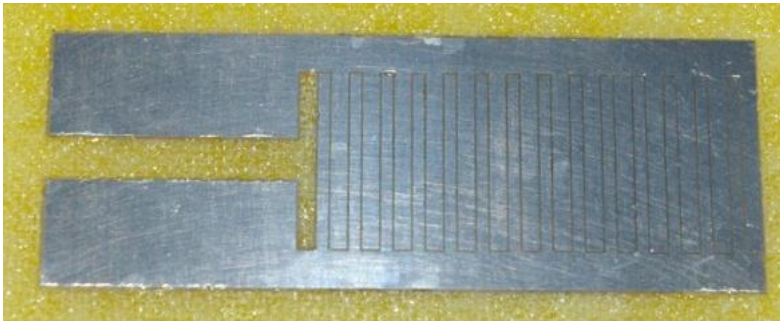

Luna interdigitated electrode  
(gold)



# Interdigitated Electrodes

## ■ Polarization resistance

- Impedance analysis used to determine  $R_p$
- Two electrode measurement
- Low frequency excitation to measure  $2R_p + R_s$
- High frequency measurement for  $R_s$

$$R_p = \frac{\left( \frac{\Delta E}{\Delta i} \right)_{\Delta E \rightarrow 0}}{2.3} = \frac{b_a b_c}{2.3(b_a + b_c) i_{corr}} \quad , \text{ or } \quad i_{corr} = \frac{B}{R_p}$$

$$Z_{\omega \rightarrow 0} = 2R_p + R_s \quad , \text{ and } \quad Z_{\omega \rightarrow \infty} = R_s$$

$$R_p = \frac{Z_{\omega \rightarrow 0} - R_s}{2}$$

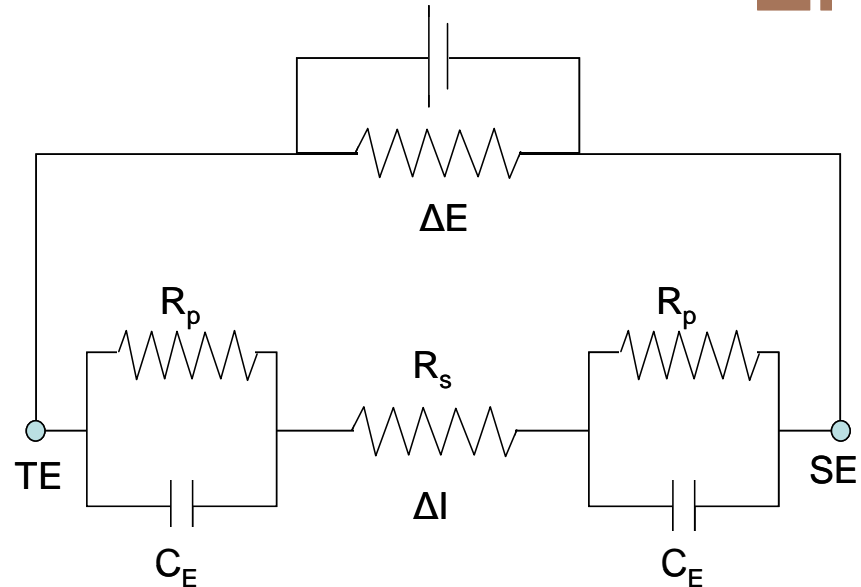
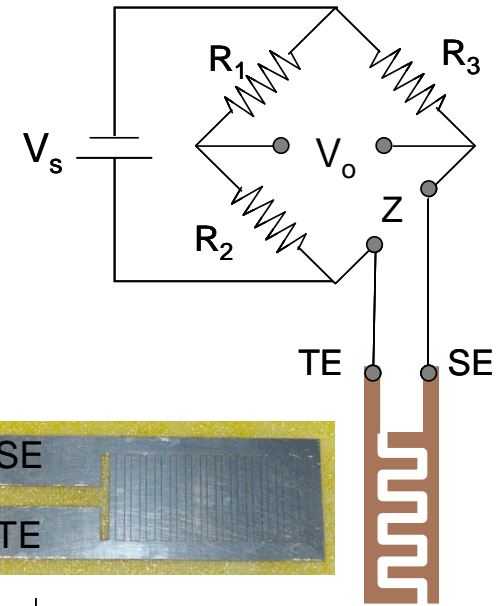

# Interdigitated Electrodes - TOW

- Impedance magnitude for Au/Au sensor excited at 1 kHz indicates TOW and deliquescence point of surface
- Relationship of RH to corrosivity is dependent on deliquescence of salt deposits and corrosion products

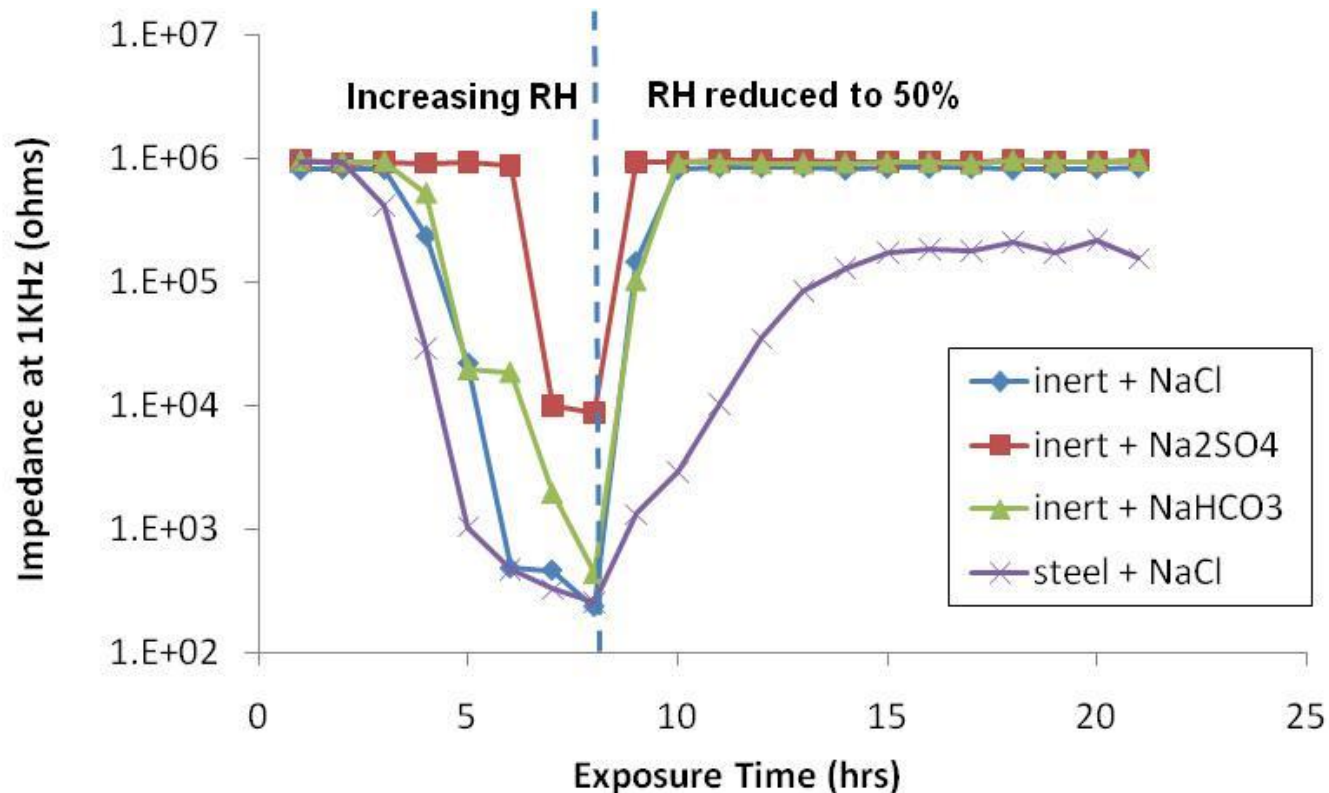

# Interdigitated Electrodes - $i_{\text{corr}}$

- Copper corrosion rates were measured by a number of techniques over a range of salt concentrations
- Flat copper plate electrodes were evaluated LPR, EIS and DC step methods
- Interdigitated electrodes were tested using low frequency (0.01 Hz) 5 mV excitation
- There is reasonable agreement between EIS with the interdigitated electrode and other measurement methods

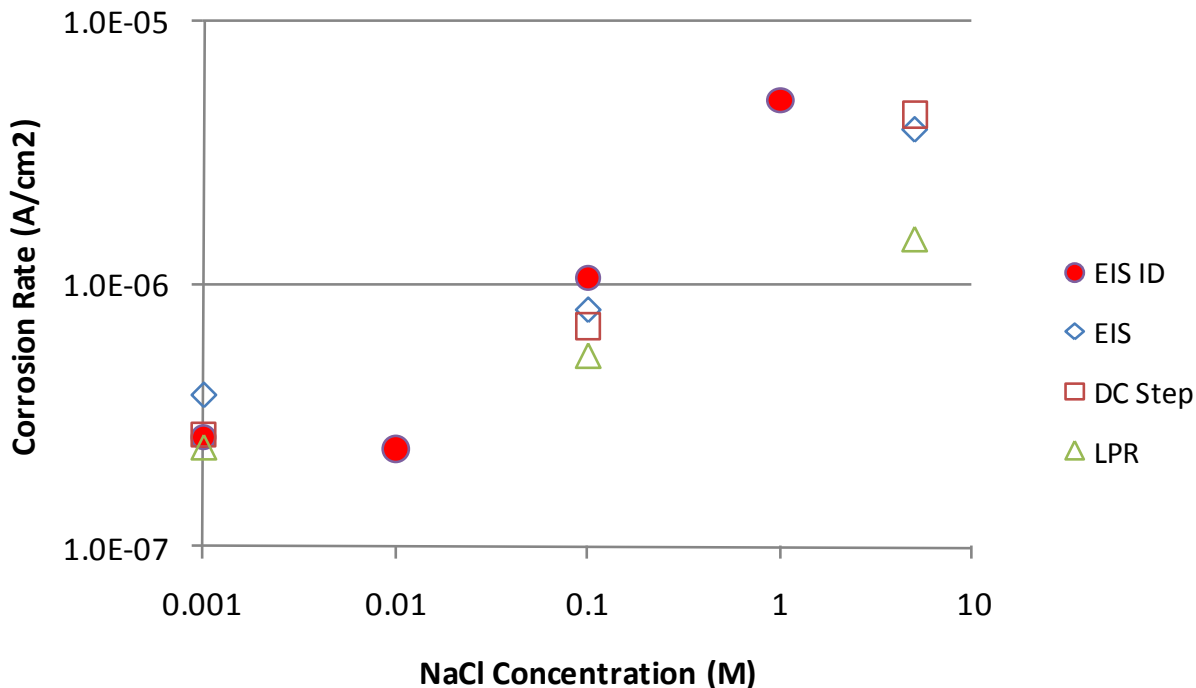

# Inductive Corrosivity Sensor

- Inductive corrosivity sensor measures cumulative corrosion damage
  - *Sensitive to localized corrosion*
  - *Coating system breakdown*
- Sensor is composed of an induction coil and sensing element (AA2024-T3 or AA7075-T6)
  - *Sensing element is fabricated so gage section has exposed end grains*

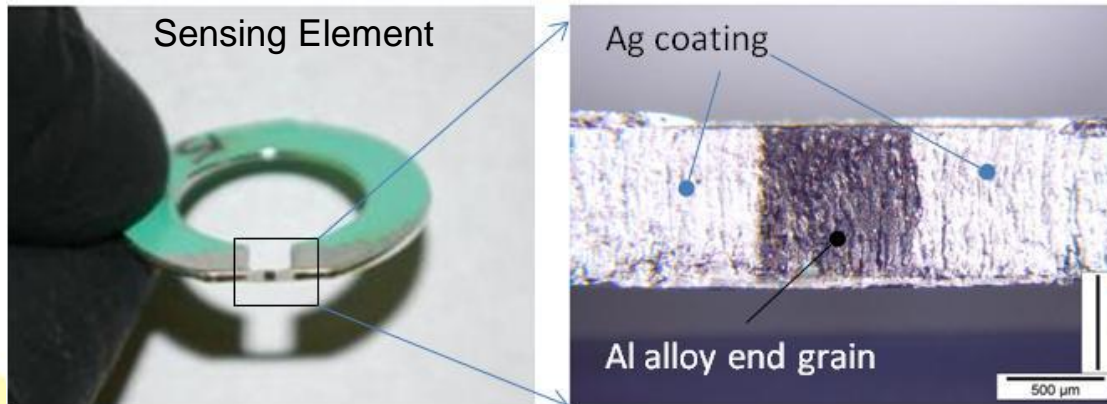

Assembled sensor

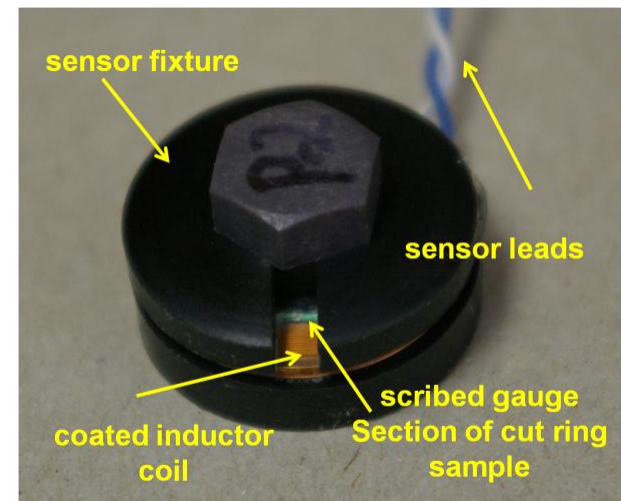



# Inductive Sensor

- Inductive sensor can detect changes in gage section geometry due to corrosion
  - AC current excitation
  - As corrosion occurs, induced EMF into sample decreases
  - Need to relate output to corrosion damage

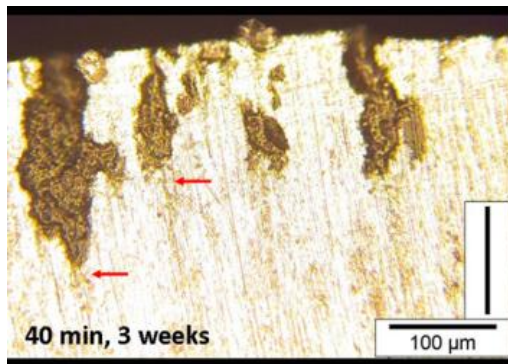

Gage cross-section

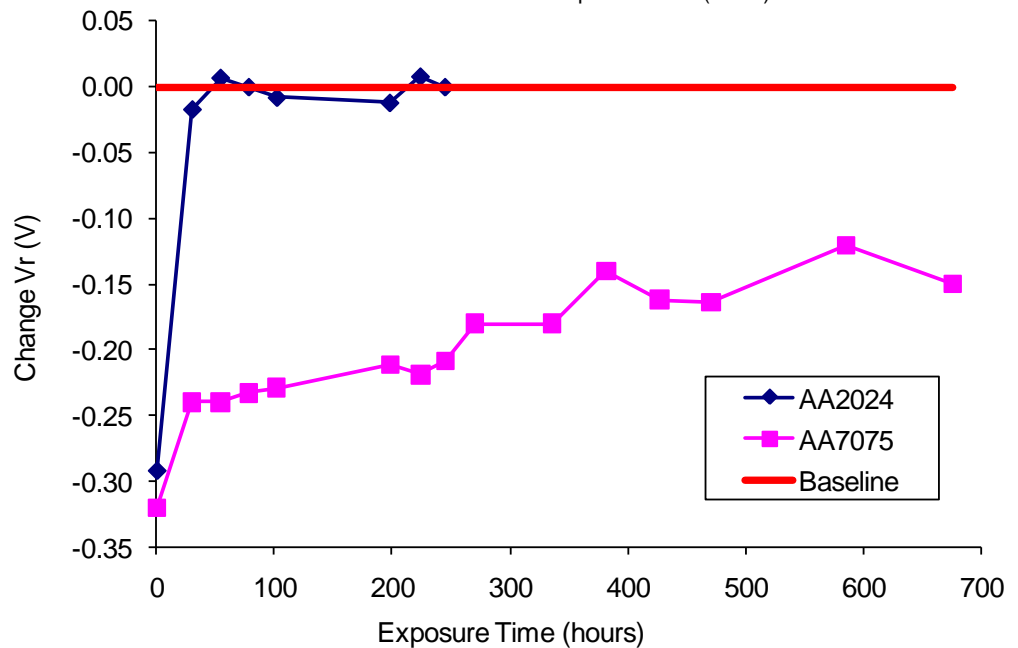
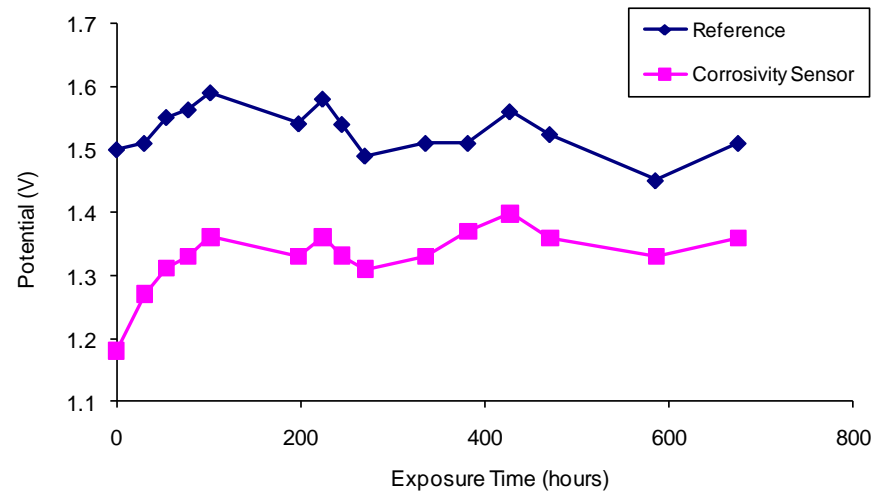

# Algorithm Development

- The system is designed to support data processing at the sensor node and hub
  - *Embedded diagnostic and prognostic routines including automated sensor validation*
  - *Data reduction decreases the overall data volume, thus requiring fewer data transmissions*
  - *Reduction in communications lowers system power consumption*
- Designed experiments and accelerated corrosion tests will be performed to establish diagnostic algorithms

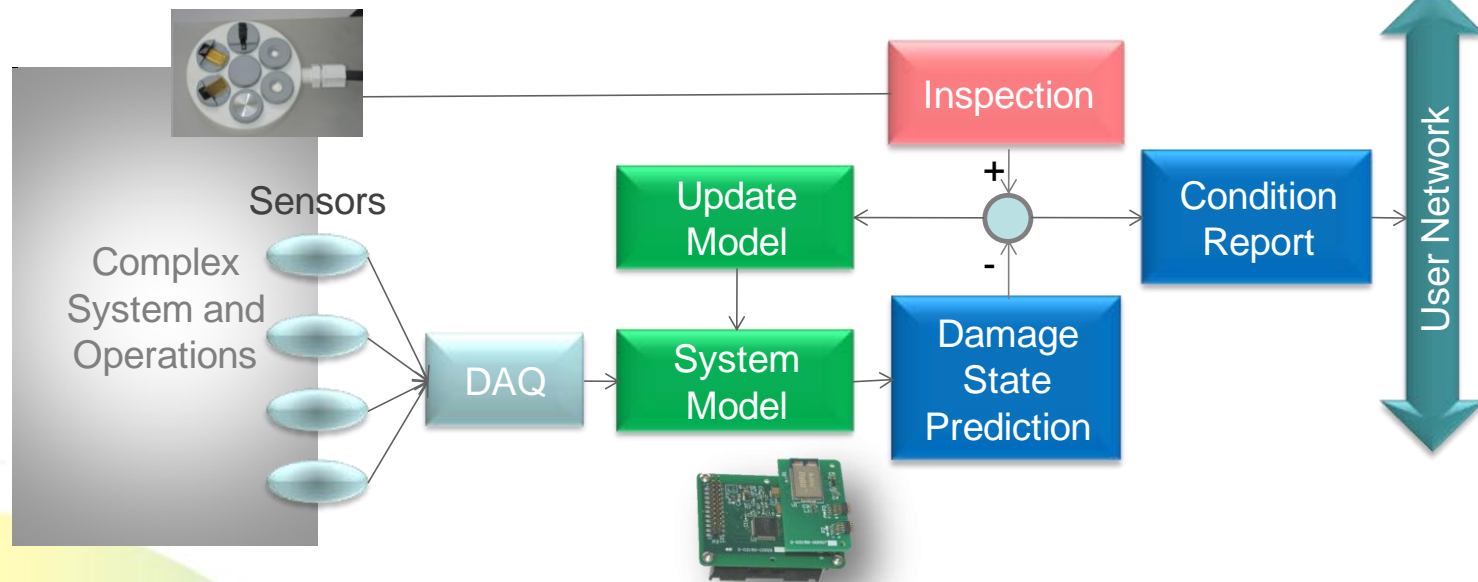



Luna Innovations Incorporated  
1 Riverside Circle, Suite  
400, Roanoke, VA 24016



Sensor Node



Sensor Hub

