



Australian Government
Department of Defence
Defence Science and
Technology Organisation

USAF Distributed Mission Operations, an ADF Synthetic Range Interoperability Model and an AOD Mission Training Centre Capability Concept Demonstrator - What Are They and Why Does the RAAF Need Them?

Lucien Zalcman and Jon Blacklock*

Air Operations Division
Defence Science and Technology Organisation

***Zalcman Consulting**

DSTO-TR-2463

ABSTRACT

Today simulation technology allows warfighters to participate in a continuous training cycle and maintain a high state of combat readiness by using cost-effective simulation alternatives in conjunction with live-fly operations and training missions. Current development of Live, Virtual, and Constructive (LVC) systems for training and mission rehearsal, the rapid advancement of networking technologies and protocol standards/architectures such as Distributed Interactive Simulation (DIS) and High Level Architecture (HLA) have all contributed to an environment where highly-distributed training, mission rehearsal, operations support, and multi-force Distributed Mission Operations (DMO) joint/coalition exercises have become a reality.

The objective of this report is to offer guidance on how to progress towards such a highly interoperable, LVC synthetic environment. Corporate LVC interoperability standards, processes, common applications and databases need to be developed so that LVC systems can be appropriately specified, delivered and accepted with an already useable level of corporate interoperability that will enable coalition LVC training “out-of-the-box”.

An AOD, Air Battle Management, Mission Training Centre (MTC) Capability Concept Demonstrator, that will provide guidance to assist the RAAF to migrate to a highly interoperable, DMO compliant, LVC synthetic environment (including a coalition training focussed, RAAF MTC), has been proposed.

RELEASE LIMITATION

Approved for public release

Published by

*Air Operations Division
DSTO Defence Science and Technology Organisation
506 Lorimer St
Fishermans Bend, Victoria 3207 Australia*

Telephone: (03) 9626 7000

Fax: (03) 9626 7999

© Commonwealth of Australia 2010

AR-014-839

October 2010

APPROVED FOR PUBLIC RELEASE

USAF Distributed Mission Operations, an ADF Synthetic Range Interoperability Model and an AOD Mission Training Centre Capability Concept Demonstrator - What Are They and Why Does the RAAF Need Them?

Executive Summary

In 1997 a prototype Mission Training Center was developed in a hangar on the flight line by researchers and engineers from the US Air Force Research Lab in Mesa, Arizona.

Four state-of-the-art F-16C simulators with wraparound visual systems were networked with two A-10 simulators, a C-130 flight simulator, and an AWACS weapons controller console. The eight simulators could fly together against computer generated air and ground threats in a virtual reproduction of the Nevada ranges. Operational pilots and controllers flew a complex mission that combined close air support, air escort, and tactical airdrop all in a single integrated training scenario. Audiences watched the mission unfold on large video monitors that showed several types of real-time views, including individual cockpit displays, aerial manoeuvring, ground movements, and weapons delivery. To many of those who witnessed this event, the networked simulators were a revolutionary training technology.

Today simulation technology allows warfighters to participate in a continuous training cycle and maintain a high state of combat readiness by using cost-effective simulation alternatives in conjunction with live-fly operations and training missions. Current development of Live, Virtual, and Constructive (LVC) systems for training and mission rehearsal, the rapid advancement of networking technologies and protocol standards/architectures such as Distributed Interactive Simulation (DIS) and High Level Architecture (HLA) have all contributed to an environment where highly-distributed training, mission rehearsal, operations support, and multi-force Distributed Mission Operations (DMO) joint/coalition exercises have become a reality.

The objective of this report is to offer guidance on how to progress towards a highly interoperable, LVC synthetic environment. This requires a set of corporate, LVC interoperability standards, processes, common applications and databases that can be used by LVC acquisition projects (i.e. as unambiguous Request For Tender specifications) so that LVC systems can be appropriately specified, delivered and accepted with an already useable level of corporate interoperability that will enable coalition LVC training “out-of-the-box”.

Such a set of corporate LVC interoperability standards can be used to design an infrastructure upon which a set of LVC interoperable simulations systems can be developed to form a US Air Force DMO compliant Mission Training Centre.

In Australia the RAAF makes no use of any LVC DMO capability whatsoever! The RAAF cannot currently participate in any USAF compliant DMO LVC coalition training exercises. The UK, Canada and NATO are moving towards these capabilities.

An AOD, Air Battle Management, Mission Training Centre Capability Concept Demonstrator comprising the AOD ADGESIM, DACS, AEW&C MST and WIRE simulation systems, that will provide guidance to assist the RAAF to migrate to a highly interoperable, DMO compliant, LVC synthetic environment, has been proposed. This AOD Mission Training Centre could be developed further to form the basis of a RAAF, USAF DMO compliant, high-fidelity, LVC training capability that could be used to provide a new coalition LVC training capability for the RAAF.

Authors

Lucien Zalcman

Insert Author's Division

Dr. Lucien Zalcman has a Ph. D. in Experimental Physics from Melbourne University and a Graduate Diploma in Computing Studies from the Royal Melbourne Institute of Technology.

Dr. Zalcman worked for DSTO for 21 years in the areas of Advanced Distributed Simulation protocols (DIS, HLA and TENA), Live-Virtual-Constructive (LVC) interoperability, interoperability standards, Synthetic Environments, Simulation Architectures, Tactical Data Link interoperability and Network Centric Warfare. In 2005 Dr. Zalcman left DSTO to set up Zalcman Consulting.

Dr. Zalcman has authored/co-authored 95 DSTO, TTCP and Zalcman Consulting research reports and conference papers.

Jon Blacklock

Air Operations Division

Jon Blacklock joined the Royal Australian Air Force as an Air Defence Officer in 1978.

Postings followed as a fighter controller, as a Space Operations Senior Director and Combat Crew Commander in the US Defense Support Program supporting nuclear non-proliferation and missile early warning systems. Staff tours were completed as Project Manager for the ADF Air 5077 Airborne Early Warning & Control Project, and in ADF HQ as requirements manager.

Mr. Blacklock joined the Defence Science and Technology Organisation (DSTO) in 2001 as Head of Air Projects Analysis in the Air Operations Division. His current activities involve the management and development of synthetic environments for training, experimentation and Force development in aerospace control and battle management.

Contents

ACRONYMS AND ABBREVIATIONS

1. INTRODUCTION.....	1
1.1 Some Modelling and Simulation Vision.....	1
1.2 Distributed Mission Operations.....	2
2. THE CONCEPT OF THE SYNTHETIC RANGE	4
2.1 Synthetic Range Interoperability in the ADF	4
2.2 What Is A Synthetic Range?.....	5
2.3 Live, Virtual and Constructive Synthetic Range Systems	6
2.3.1 Live Systems.....	6
2.3.2 Virtual Systems.....	6
2.3.3 Constructive Systems.....	7
2.3.4 Synthetic Systems.....	7
2.4 Some Other Useful Definitions	8
2.4.1 Interoperability Between Simulations.....	8
2.4.2 DIS.....	8
2.4.3 HLA.....	9
2.4.4 The RPR-FOM.....	10
2.4.5 TENA	11
2.4.6 SIMPLE.....	11
2.4.7 SISO-J.....	12
2.4.8 JREAP	12
2.5 The Synthetic Range Interoperability Model.....	13
2.6 Section Summary.....	17

3.	ADF CORPORATE INTEROPERABILITY STANDARDS	18
3.1	Advanced Distributed Simulation Interoperability	19
3.2	Tactical Data Link Interoperability.....	21
3.3	Radio Communications Interoperability	21
3.4	Section Summary	22
4.	SYNTHETIC RANGE INTEROPERABILITY WITH COALITION LVC SYSTEMS.....	22
4.1	The USA Multi-Service Distributed Environment Test Event Exercises.....	22
4.1.1	Distributed Simulation Interoperability	24
4.1.2	Tactical Data Link Interoperability	25
4.1.3	Radio / Voice Communications Interoperability	25
4.2	Synthetic Range Interoperability with USAF (DTE 5) DMOC Systems.....	26
4.2.1	Advanced Distributed Simulation Interoperability.....	26
4.2.2	Tactical Data Link Interoperability	29
4.2.3	Radio Communications Interoperability.....	30
4.2.4	The US Air Force DMO Synthetic Range Interoperability Model.....	30
4.3	Synthetic Range Interoperability with USN (DTE 5) Systems	31
4.4	The US Army DTE 5 Interoperability Model.....	34
4.5	Section Summary	35
5.	WHICH COALITION SYNTHETIC RANGE INTEROPERABILITY MODEL SHOULD THE RAAF CONSIDER ?	39
5.1	The US Army LVC-IA Program	39
5.2	The UK MOD MTDS Program.....	39
5.3	The UK MOD Maritime Airborne Surveillance and Control Experiment System	41
5.4	The NATO Live, Virtual and Constructive Project	42

5.5	The Norwegian Defence Research Establishment Joint Tactical Training Capability Prototype (JTTCP) System.....	43
5.6	The Canadian Air Force	45
5.7	NATO Interoperability Standards.....	46
5.8	Comparison of Synthetic Range Interoperability Models.....	50
5.9	Section Summary	51
6.	THE USAF LVC DISTRIBUTED MISSION OPERATIONS (DMO) SYSTEM ...	52
6.1	The US Air Force DMO System	52
6.2	Why Do We Need Such Systems?.....	54
6.3	DMO Components	58
6.4	DMO LVC (Simulation) Assets.....	59
6.5	DMON - The DMO Network	60
6.6	DMO Interoperability Standards	61
6.6.1	The Network Standard.....	62
6.6.2	DMT/CAF DMO Distributed Interactive Simulation (DIS) Standard	62
6.6.3	High level Architecture (HLA) Reference Federation Object Model (RFOM) Standard	62
6.6.4	Security Standard	63
6.6.5	Event Control Standard.....	63
6.6.6	Data Sharing Standard	63
6.6.7	Common Models Standard.....	63
6.6.8	Conformance Testing Standard.....	64
6.6.9	Threat Representation and Computer Generated Forces Standard	64
6.6.10	Technical Performance Standard.....	64
6.6.11	Synthetic Natural Environment Standard	65

6.6.12	Visualisation Standard	65
6.7	DMO Integration and Test Methodology	65
6.8	DMO Portals	66
6.9	DMO Mission Training Centers (MTCs)	68
6.10	Section Summary	69
7.	WHERE TO NOW FOR THE RAAF?	69
7.1	Coalition LVC Interoperability	69
7.2	Future Integration of Live LVC Coalition Systems	70
7.3	Virtual Flag Exercises	73
7.4	Authority to (Inter)Operate	73
7.4.1	The Legal Authority to Operate	73
7.4.2	The Security Authority to Operate	74
7.4.3	The Funding Authority to Operate	75
7.5	Integration of LVC Systems	75
7.5.1	The DSTO (AOD) Net Warrior Initiative	75
7.5.2	What Are Mission Training Centres?	77
7.5.3	An AOD Mission Training Centre Capability Concept Demonstrator	78
7.5.4	A RAAF Air Battle Management Mission Training Centre	80
7.6	Section Summary	82
8.	CONCLUSIONS AND RECOMMENDATIONS	82
9.	REFERENCES	85

Acronyms and Abbreviations

AAR	After Action Review
ABM	Air Battle Management
ACMI	Air Combat Manoeuvring Instrumentation
ADF	Australian Defence Force
ADFTA	ADF Tactical Data Link Authority
ADGE	Air Defence Ground Environment
ADGESIM	Air Defence Ground Environment SIMulator
ADS	Advanced Distributed Simulation
AEW&C	Airborne Early Warning & Control
AOD	Air Operations Division
AWACS	Airborne Warning and Control System
BFTT	USN Battle Fleet Tactical Trainer
BVR	Beyond Visual Range
CAF	US Combat Air Force
CCD	Capability Concept Demonstrator
CCD	Common Connectivity Device
CFBL	Combined Federated Battle Lab network
CFST	RAN/USN Coalition Fleet Synthetic Training exercises
CGF	Computer Generated Forces
ConOps	Concept of Operations
COTS	Commercial-Off-The-Shelf
DACS	Desktop Aircraft Cockpit Simulator
DFA	USAF DIS Filter/Analyser
DIS	Distributed Interactive Simulation
DMO	Distributed Mission Operations
DMOC	Distributed Mission Operations Centre
DMON	Distributed Mission Operations Network
DMT	Distributed Mission Training

DTN	Distributed Test Network
DSTO	Defence Science and Technology Organisation
DTE	Distributed Test Event
FAC	Forward Air Controller
FOM	Federation Object Model
GOTS	Government-Off-The-Shelf
GUI	Graphical User Interface
HACTS	Hornet Air Crew Training System
HIL	Human-In-the-Loop
HLA	High Level Architecture
IEEE	International Electronic and Electrical Engineers
IFF	Identify Friend or Foe
IP	Internet Protocol
JTTCP	Norwegian Joint Tactical Training Capability Prototype
JNTC	US Joint National Training Capability
JREAP	Joint Range Extension Application Protocol
JSF	US Joint Strike Fighter
JTEN	US Joint Training & Experimentation Network
JTIDS	Joint Tactical Information Distribution System
LAN	Local Area Network
LVC-IA	US Army Live-Virtual-Constructive – Integrating Architecture
LVC	Live-Virtual-Constructive
MASC	UK Ministry of Defence NITeworks Maritime Airborne Surveillance and Control
MATREX	Modeling Architecture for Technology, Requirements and Experimentation
MIDS	Multifunctional Information Distribution System
M&S	Modeling & Simulation
MECs	Mission Essential Competencies
MSCT	Multi-Source Correlator/Tracker
MST	AOD AEW&C Mission System Testbed

MTDS	UK MOD (i.e. RAF) Mission Training through Distributed Simulation
MWTC	Maritime Warfare Training Centre
MTC	Mission Training Centre
NASMP	US Navy's Naval Aviation Simulation Master Plan
NATO	North Atlantic Treaty Organization
NCW	Network Centric Warfare
NLVC	NATO Live-Virtual-Constructive
NMSSP	NATO Modelling and Simulation Standards Profile
PDU	DIS Protocol Data Unit
PPLI	Precise Participant Location and Identification
PSI	The ADGESIM Pilot Simulator Interface
RAAF	Royal Australian Air Force
RAF	Royal (UK) Air Force
RAN	Royal Australian Navy
RFT	Request For Tender
RPR-FOM	Real-time Platform Reference Federation Object Model
RTAVS	Real-Time All Vehicle Simulator
RTI	Runtime Infrastructure
SATCOM	Satellite Communications
SIMPLE	Standard Interface for Multiple Platform Link Evaluation
SISO	Simulation Interoperability Standards Organization
STANAG	NATO STANdardization AGreement
TAARDIS	The ADGESIM After Action Review (DIS) Suite
TACCSF	USAF Theater Air/Aerospace Command and Control Simulation Facility
TCP	Transmission Control Protocol
TCP/IP	Transmission Control Protocol/Internet Protocol
TDL	Tactical Data Link
TENA	Test and Training Enabling Architecture
TSPi	Time-Space-Position information

UA	Underwater Acoustic
USAF	US Air Force
USJFCOM	US Joint Forces Command
USN	US Navy
VoIP	Voice over IP
VMF	Variable Message Format
WAN	Wide Area Network

1. Introduction

1.1 Some Modelling and Simulation Vision

The Australian Defence Force (ADF) vision for simulation is [ADF DI(G) OPS 42-1]

“Defence exploits simulation to develop, train for, prepare for and test military options for Government wherever it can enhance capability, save resources or reduce risk.”

The NATO Modelling and Simulation Vision (M&S) is [NATO M&S Vision]

“NATO exploits modeling and simulation to enable NATO transformation to enhance capability, increase interoperability, save resources or reduce risk in the application areas of training, support to operations, defence planning and capability development.

where the following terms are defined as:

- *Enhance Capability - NATO is heavily involved in the capability development process from understanding the future strategic environment to identifying and assessing possible solutions. M&S can enable the development of new training, operations support, and defence planning capabilities by facilitating the evaluation of doctrine, organization, training, materiel, leadership development, personnel, facilities and interoperability issues;*
- *Increase Interoperability – Interoperability in NATO is the ability to operate together. M&S can be used to increase NATO interoperability at all levels (force, HQs, organizations, systems, etc) by supporting, for example training, education, exercises, mission rehearsal, test and evaluation, concept development and experimentation or certification. In particular, M&S can be used to improve interoperability in multinational operations by distributed, networked utilization of NATO and national M&S centres and systems;*
- *Save Resources – Resources can be material, fiscal or labour. For example, the use of M&S to examine and/or validate possible solutions offers an alternative approach from the traditional costly test and evaluation methodology. Also, military forces and resources are limited and M&S can be used to provide synthetic environments to compare options and courses of action enabling more efficient and cost-effective defence planning and operational performance. Finally, M&S solutions based on distributed, networked use of NATO and national assets will assist in accomplishing this goal;*
- *Reduce Risk – There are many categories of risk, some of them being risk to human life or material. For instance, in military training, experimentation, and operations there is inherent risk due to the dangerous nature of the environment. M&S may substantially reduce risk by providing a safe synthetic environment in which all or part of the event is conducted. M&S can also provide tools for analysis to foster a more complete understanding and appreciation of both military and non-military aspects of an operational situation, thereby helping commanders make more*

informed decisions by offering comparisons of alternative courses of action thus reducing risk or saving resources.”

1.2 Distributed Mission Operations

In 1997 a prototype Mission Training Center was developed in a hangar on the flight line by researchers and engineers from the US Air Force (USAF) Research Lab in Mesa, Arizona.

Four state-of-the-art F-16C simulators with wraparound visual systems were networked with two A-10 simulators, a C-130 flight simulator, and an AWACS weapons controller console. The eight simulators could fly together against computer generated air and ground threats in a virtual reproduction of the Nevada ranges. Operational pilots and controllers flew a complex mission that combined close air support, air escort, and tactical airdrop all in a single integrated training scenario. Audiences watched the mission unfold on large video monitors that showed several types of real-time views, including individual cockpit displays, aerial maneuvering, ground movements, and weapons delivery. To many of those who witnessed this event, the networked simulators were a revolutionary training technology [Chapman].

Today (a decade later in 2007) simulation technology allows war-fighters to participate in a continuous training cycle and maintain a high state of combat readiness by using cost-effective simulation alternatives in conjunction with live-fly operations and training missions. Current development of live, virtual, and constructive (LVC) systems for training and mission rehearsal, the rapid advancement of networking technologies and protocol standards/architectures such as Distributed Interactive Simulation (DIS) and High Level Architecture (HLA) have all contributed to an environment where highly-distributed training, mission rehearsal, operations support, and multi-force Distributed Mission Operations (DMO) joint/coalition exercises have become a reality [Portrey].

“Experimentation and virtual and simulated environments will be crucial to building appropriate skill-sets and experience in our people, and the RAAF will need to develop a simulation capability that can exercise and experiment with both operating strategies and organisational structures. Quality simulation and exercising will be used to educate and train, and will also mitigate developmental and operational risk by allowing us to explore our new systems virtually before delivery into operational service. We did this successfully for our new AEW&C system under a program called “Armchair Warrior”, and such programs will become more prevalent and sophisticated as we evolve. Harnessed with simulation, experimentation will not only develop a level of professional mastery in personnel, but can be used to help us decide on the RAAF’s preferred operational and organisational shape, and pre-adapt it for new systems (2007)”. [AAP 1000-F]

There are currently no formal ADF corporate interoperability standards for ADF LVC systems. Without such (appropriately specified) corporate interoperability standards ADF LVC systems may be acquired with interoperability capabilities but may (i.e. will most likely) not be able to interoperate with each other.

The objective of this report is to offer guidance on how to progress towards a highly interoperable, ADF LVC corporate synthetic environment (i.e. Synthetic Range). This requires a set of corporate, LVC interoperability standards, processes, common applications and databases that can be used by LVC acquisition projects (i.e. as unambiguous RFT specifications) so that LVC systems can be appropriately specified, delivered and accepted with an already useable level of corporate interoperability that will enable coalition LVC training “out-of-the-box”.

Section 2 describes the Concept of the Synthetic Range and the Synthetic Range Interoperability Model that simplify the development of a Synthetic Range architecture and thus the integration (i.e. interoperability) of participating Synthetic Range Interoperability Model compliant, LVC systems. The Synthetic Range Interoperability Model simplifies the unambiguous specification of the required interoperability standards, processes, common applications and databases.

Section 3 discusses what corporate interoperability standards are and how the Synthetic Range Interoperability Model helps to define such interoperability standards.

Section 4 analyses some available experimental data and compares the various interoperability models used by Australia and some of its coalition partners. This analysis also demonstrates how to connect LVC systems that implement different architectures (i.e. Synthetic Range Interoperability Models) using available COTS/GOTS Gateway products. This analysis is developed further in section 5 and shows that coalition Services use very similar interoperability standards. Coalition Air Forces trend towards support for the same interoperability standards that are used by the USAF.

Section 6 provides a more detailed discussion of the important interoperability components of the USAF Distributed Mission Operations Program which is moving towards support for coalition LVC training.

Section 7 discusses further points of interest regarding LVC coalition interoperability and how the ADF/RAAF/AOD can move forward and prepare for the future including LVC Live platform interoperability.

An AOD, Air Battle Management, Mission Training Centre Capability Concept Demonstrator (CCD) comprising the AOD ADGESIM, DACS and AEW&C WIRE simulation systems, that will provide guidance to assist the RAAF to migrate to a highly interoperable, DMO compliant, LVC synthetic environment, has been proposed. This AOD Mission Training Centre CCD could be developed further to form the basis of a RAAF, high-fidelity, LVC training capability that could be used to provide a new coalition LVC training capability for the RAAF.

Final conclusions and recommendations are presented in section 8.

2. The Concept of the Synthetic Range

2.1 Synthetic Range Interoperability in the ADF

The Concept of the Synthetic Range, including the Synthetic Range Interoperability Model, provides a simplified way of understanding how military Live, Virtual and Constructive (LVC) systems (see section 2.3 for definitions of Live, Virtual and Constructive systems) can interoperate.

Australian Defence Force (ADF) training relies mainly on simulators and operational platform training for combat crew readiness. When little networked capability is available (as for the RAAF), stand-alone simulators primarily emphasise:

- abnormal / emergency procedure training; or
- platform specific training

thus providing limited capability to prepare combat ready crews for joint and coalition team operations.

Large-scale, operational exercises provide opportunities to train crews in team and inter-team skills. However cost, fatigue life concerns, range site capabilities, weather, and frequency of event limitations make this only a partial solution to crew readiness training. A significant gap exists between training obtained using stand-alone simulators and training obtained during live training exercises for combat crews. Alternative training methods, such as Synthetic Range LVC training, should be considered to maintain crew readiness [Blacklock (2007)].

Such alternative training methods would allow LVC players at multiple sites to participate in synthetic environment training exercises ranging from individual and team participation to full theatre-level battles. Advantages arise such as increased value and efficiency of actual operational platform hours, improved communication skills in a joint and coalition environment, and an increased sense of trust and confidence amongst participants [Cochrane].

Simulation, when combined with a competency-based training program and live-flying training, can reduce the distance between continuation training and combat mission readiness [Portrey].

The Royal Australian Navy (RAN) FFG, ANZAC and FFG Up ship team training systems at the Maritime Warfare Training Centre (MWTC) at HMAS WATSON are already synthetic range compliant. These MWTC ship team training simulation systems already support the recommended ADF Corporate Synthetic Range Interoperability Model (see section 3 and Tables 13 and 14). The HMAS WATSON ship team training simulation systems appear to support a Synthetic Range Interoperability Model similar (if not identical) to the Synthetic Range Interoperability Model used by the US Navy (see section 4.3).

Over a period of several years all major operational USN platforms have had Synthetic Range compliant, **Battle Fleet Tactical Trainer (BFTT)**, **On-Board-Training-Systems** fitted [Clark (2006)], [Clark (2007)], [MacDonald]. Over a similar period the Synthetic Range compliant MWTC systems at HMAS WATSON have participated in regular experimental, coalition training exercises with such USN BFTT systems - including real (i.e. Live) USN ships [Ryan].

The actual RAN FFG UP ships (i.e. Live platforms) are also Synthetic Range compliant in that their **On-Board-Training-Systems** (embedded training systems) that are tightly coupled (i.e. embedded) into their combat systems comply with the Synthetic Range Interoperability Model (i.e. interoperability standards) used by the US Navy (section 4.3). The MWTC FFG UP trainer uses much of the same equipment as is onboard the FFG Up ship - it is a high-fidelity stimulated team training system. The FFG UP architecture is (basically) identical to that of the USN BFTT systems which are highly compliant with the Synthetic Range Interoperability Model.

The DSTO developed RAAF Air Defence Ground Environment SIMulator (ADGESIM), the Airborne Early Warning and Control Aircraft Operational Mission System (AEW&C OMS) and the Hornet (F/A-18A/B and C/D) Air Crew Training System (HACTS) systems will all be co-located at the RAAF Williamtown Air Base. If these systems could interoperate they could form a RAAF Air Battle Management Mission Training Centre (MTC) [Blacklock (2007)] that could provide an initial RAAF capability to conduct virtual large-force development and training with little impact to logistics, environment, and war fighting resources (Section 7.5). Such a multi-system, high-fidelity simulation capability has not previously been available to the RAAF.

2.2 What Is A Synthetic Range?

Synthetic range LVC systems can interoperate over a network in a common virtual synthetic environment no matter where these systems are geographically located throughout the world.

Synthetic Range systems can share the same common (“ground truth”) scenario on an advanced distributed simulation network.

Real operational (i.e. Live) systems share their situation awareness picture over “real-world, military networks” mainly using terrestrial, satellite, and tactical data link systems such as Link-16 and Link-11. To provide realistic Service, Joint and Coalition training Synthetic Range LVC systems must also share their operational, tactical data link system information in ways similar to the way that real, operational platforms would normally share this information.

Real world, military grade, voice/intercom communications interoperability between Synthetic Range LVC military systems must also be supported to allow operations in the synthetic environment space to interoperate with Live operational systems.

In a synthetic (LVC) range the entirety of the test and training event will be represented in a virtual synthetic environment world where the location of the entities in the virtual

environment may bear no relationship to the real, geographical location of the participating LVC systems.

According to Daly et al. [Daly]

“Synthetic environments are simulations that represent activities at a high level of realism. These environments may be created within a single computer or over a distributed network connected by local and wide area networks and augmented by realistic special effects and accurate behavioural models. They allow visualisation of, and immersion into, the environment being simulated” [US].

2.3 Live, Virtual and Constructive Synthetic Range Systems

A synthetic range system can be broadly classified as belonging to one of three different types of systems - Live, Virtual, or Constructive (LVC).

2.3.1 Live Systems

Live systems are “instrumented” real world, operational military platforms. Instrumentation (Embedded or On-Board-Training-Systems, Air Combat Manoeuvring Instrumentation (ACMI) systems [Cubic], etc) attached to these Live systems can provide information such as location, system orientation, movement, weapon status, etc. to the synthetic range distributed simulation network in real-time such that this data can interoperate in the synthetic range virtual environment. Live system data may need to be distributed via radio telemetry to a dedicated, ground station where it is distributed to other synthetic range participants using standardised, simulation network protocols. In the same way, data from other synthetic range participants must be converted from the standardised simulation network protocols and provided in an appropriate form to the Live, synthetic range compliant systems (see Section 7.2).

Live training exercises real people using real equipment in a real environment [UK]. Live Simulation is defined as simulation involving real people operating real systems [NATO M&S Vision]. The Navy conducts this type of training at sea using steaming hours while ships are under way [Daly].

2.3.2 Virtual Systems

Virtual systems comprise training and experimentation simulators (Human-In-the-Loop (HIL) simulators) that are crewed by people. These systems may have advanced distributed simulation capabilities that use simulation network protocols. However some form of common connection gateway device may be required to convert the simulation system protocols to (required) corporate standard, synthetic range, interoperability protocols.

Virtual training exercises real people using simulated equipment in a simulated environment [UK]. NATO defines Virtual Simulation as simulation involving real people operating

simulated systems [NATO M&S Vision]. Virtual training usually involves wargaming in-house (in a building) using simulation equipment [Daly].

2.3.3 Constructive Systems

Constructive systems are entirely synthetic representations of both platforms and people - they act according to software rules rather than through human direction.

Constructive training exercises simulated people using simulated equipment in a simulated environment [UK]. NATO defines Constructive Modeling or Simulation as models and simulations that involve simulated people operating simulated systems [NATO M&S Vision]. It is the most “artificial” of all active (i.e. , non-classroom) training and it involves only the practical application of cognitive skills. Constructive training can include personal computer (PC) or tabletop war-gaming. This training focuses primarily on strategic, operational, or tactical decision-making [Daly].

Interoperability between LVC systems within a common scenario requires compliance with an agreed set of interoperability standards including network infrastructure, data, interoperability protocols, platform/environment representation, etc. This requires the development of an interoperability model (the Synthetic Range Interoperability Model) that is a crucial part of the synthetic range architecture. All synthetic range systems that are compliant with this set of interoperability standards (i.e. the interoperability model) should be interoperable regardless of whether the systems are Live, Virtual or Constructive systems.

2.3.4 Synthetic Systems

Daly et al. also define a separate Synthetic system category - this category involves a combination of real components interoperating with virtual components. They define synthetic training as “exercising real people (and simulated people/notional actors) using real equipment in a simulated or synthetic environment.”

According to Daly et al. synthetic training applies to in-port training where trainees interact with the ship’s actual equipment but the ship is moving in a virtual area of operations. The Daly et al. version of the various training delivery methods is shown in Table 1.

Table 1 Simulated (sim) and real characteristics of training delivery methods

Training Delivery Method	People	Equipment	Environment
Constructive	Simulated	Simulated	Simulated
Virtual	Real	Simulated	Simulated
Synthetic	Real	Real	Simulated
Live	Real	Real	Real

The more common definitions (Table 2) actually refer to the training systems rather than the training delivery method.

Daly at al. differentiate between Synthetic training (delivery method) that occurs using real people using real equipment in a virtual environment and Live training that occurs using the same real people and the same real equipment but this Live training occurs in the real environment not a virtual environment.

This difference in definition disappears if the definition applies to the training system whereby a Live training system can be used using real people operating real equipment either in a real environment (the traditional way of training) or in a virtual environment using the latest training equipment and technologies.

2.4 Some Other Useful Definitions

2.4.1 Interoperability Between Simulations

The NATO Modelling and Simulation Standards Profile (NMSSP) defines interoperability between simulations as:

- The capability for simulations to physically interconnect, to provide (and receive) services to (and from) other simulations, to use these exchanged services in order to effectively work together. This definition refers mainly to “technical interoperability” that means the possibility to physically interconnect then communicate. A lot of additional work has to be done after interconnection is ensured, to reach higher levels of interoperability (semantic or substantive interoperability) [NATO NMSSP].

Table 2 More Commonly Used LVC System Definitions.

- **Live** = real people in real locations using real equipment
- **Virtual Simulation** = real people in simulators
- **Constructive Simulation** = simulated entities in a simulated environment

2.4.2 DIS

The NATO Modelling and Simulation Standards Profile describes DIS (IEEE 1278.1/A Distributive Interactive Simulation) as:

- DIS is an interoperability standard based on exchanges of formatted messages between simulation applications. Simulation state information and interactions are encoded in

messages known as Protocol Data Units (PDUs) and are exchanged between hosts using existing transport layer protocols, though normally broadcast User Datagram Protocol (UDP) is used;

- More than 15 years of use in many NATO countries; very mature technology; and
- DIS is a protocol for linking simulations of various types at multiple locations to create realistic, complex, virtual worlds for the simulation of highly interactive activities. This protocol can be used to bring together systems built for separate purposes, technologies from different eras, products from various vendors, and platforms from various services, and permits them to interoperate. DIS exercises are intended to support a mixture of virtual entities with computer controlled behaviour (computer generated forces), virtual entities with live operators (human-in-the-loop simulators), live entities (operational platforms and test and evaluation systems), and constructive entities (wargames and other automated simulations). There are many operational implementations in various nations. Best example is the US Air Force Distributed Mission Operation (DMO) programme. The primary limitation of this standard is that it is applicable to only real time (simulated time = wall clock time) simulation and has a fixed object model defined at the platform level.

2.4.3 HLA

The NATO Modelling and Simulation Standards Profile describes HLA (IEEE 1516 High Level Architecture) as:

- The High Level Architecture for M&S (HLA) is defined by three technical documents. The standards contained in this architecture are interrelated and need to be considered as a product set, as a change in one is likely to have an impact on the others. As such, the HLA is an integrated approach that has been developed to provide a common architecture for simulation;
- The Framework and Rules is the capstone document for a family of related HLA standards. It defines the HLA, its components, and the rules that outline the responsibilities of HLA federates and federations to ensure a consistent implementation. The Federate Interface Specification defines the standard services of, and interfaces to, the HLA Runtime Infrastructure (RTI). These services are used by the interacting simulations to achieve a coordinated exchange of information when they participate in a distributed federation. The Object Model Template provides a specification for describing object models that define the information produced or required by a simulation application, and for reconciling definitions among simulations to produce a common data model for mutual interoperation;
- The High Level Architecture is a technical architecture developed to facilitate the reuse and interoperation of simulation systems and assets. The HLA provides a general framework within which developers can structure and describe their simulation systems and/or assets, and interoperate with other simulation systems and assets. The HLA consists of three main components;

- The first component specifies the Framework and Rules. The second component provides the interface specifications. The third component describes the Federation Object Model requirements in the Object Model Template (OMT) Specification;
- HLA is widely implemented within NATO and PfP (Partnership for Peace) nations. There are a wide variety of commercial, open source and government support tools; and
- HLA is not “plug and play”. Some parts of the standards are left open to the RTI implementer, thus different RTIs are not guaranteed to interoperate.

2.4.4 The RPR-FOM

The NATO Modelling and Simulation Standards Profile describes the RPR-FOM Standard for Real-time Platform-level Reference Federation Object Model (SISO-STD-001.1-1999) as:

- The RPR FOM is a reference FOM that defines HLA classes, attributes and parameters that are appropriate for real-time, platform-level simulations. Applications that have previously used DIS (or would have considered using DIS), often use the RPR FOM (or a derivative of it) when interoperating in a HLA world. The RPR FOM was developed by a SISO Product Development Group (PDG). Its goal was not to just implement the DIS Protocol Data Unit structures within HLA object and interaction classes, but rather to provide an intelligent translation of the concepts used in DIS to an HLA environment;
- While the HLA Standards dictate how federates exchange data, it is a Federation Object Model (FOM) that dictates what data is being exchanged in a particular federation. HLA does not mandate the use of any particular FOM however several "reference FOMs" have been developed to promote a-priori interoperability. That is, in order to communicate a set of federates must agree on a common FOM (among other things). Reference FOMs provide ready-made FOMs that are supported by a wide variety of tools and federates. Reference FOMs can be used as-is or can be extended to add new simulation concepts that are specific to a particular federation or simulation domain;
- A companion document, known as the GRIM (Guidance, Rationale, and Interoperability Mappings) provides documentation for the RPR FOM. This document is known as SISO-STD-001-1999;
- RPR FOM 1.0 is based on the IEEE 1278.1-1995 version of the DIS Standard and became a SISO standard in 1999. It corresponds to the version US DoD 1.3 version of HLA. RPR FOM 2.0 will correspond to the IEEE 1278.1/A version of DIS;
- Enables federations of real-time, platform-based simulations, typically allowing DIS users to achieve HLA compliance;
- Is in use in many HLA federations; and
- Limitations of this Standard: Mainly targeted to entity-level simulations. Not suitable to be used at operation level.

2.4.5 TENA

The NATO Modelling and Simulation Standards Profile describes TENA (The Test and Training Enabling Architecture) as:

- TENA is a product of the Foundation Initiative 2010 (FI 2010) project, sponsored by the Central Test and Evaluation Investment Program. The core of TENA is the TENA Common Infrastructure, including the TENA Middleware, the TENA Repository and the TENA Logical Range Data Archive. TENA also specifies the existence of a number of tools and utilities, including those necessary for the efficient creation of a logical range. Range instrumentation systems (also called range resource applications) and all of the tools interact with the common infrastructure through the medium of the TENA object model. The TENA object model encodes all of the information that is transferred between systems during a range event. It is the common language with which all TENA applications communicate;
- Is widely used within the US range community and actively managed through an Architecture management Team;
- Can be used for Live Range Interoperability, LVC Interoperability, Test Interoperability;
- The initial implementation for TENA is to interoperate with US National Test and Training Ranges. It has been used at USJFCOM to incorporate Live and Range assets into LVC Training exercises. See <https://www.tena-sda.org/display/intro/news> for extensive listing of program usage; and
- Is currently targeted for real-time applications only.

2.4.6 SIMPLE

The NATO Modelling and Simulation Standards Profile describes SIMPLE (Standard Interface for Multiple Platform Link Evaluation - STANAG 5602) as:

- STANAG 5602 (SIMPLE) provides specifications for a common standard to interconnect ground rigs of all types (e.g. simulation, integration facilities etc.) for the purpose of Tactical Data Link (TDL) Interoperability testing. The STANAG specifies the distributed transfer using the IEEE Distributed Interactive Simulation (DIS) protocols which are defined in the IEEE 1278.1 and 1A standards;
- The second version of SIMPLE was promulgated in 2006 and the next version (edition 3) is under ratification. The standard is evolving thanks to feedback coming from a large basis of users;
- SIMPLE STANAG specifies the requirements for transfer of data between remote sites in different locations to support interoperability testing of TDL implementations in the different platforms of NATO Nations and Organisations;
- Is used in NATO; and

- Is not fully/only targeted to simulation interoperability. It was not originally designed to model Link-16 for training, but testing only. The standard does not model all Link-16 capabilities, such as net entry, net exit, perceived versus actual position, Link-16 relay, message encryption, and Time Slot Reallocation. It is only based on DIS and does not address HLA federations' requirements. It is applicable to Real-Time simulation applications.

2.4.7 SISO-J

The NATO Modelling and Simulation Standards Profile describes SISO-J - (Tactical Data Information Link - Technical Advice and Lexicon for Enabling Simulations - referred to as SISO-STD-002-2006) as:

- There are immediate operational requirements for existing military simulations to exchange Link-16 data using a single interoperable standard. The purpose of this standard is to meet this need by providing a standard for simulating the Link-16 protocol. This standard defines 5 fidelity levels, from message exchange only to Link-16 network modelling, including Return Trip Timing messages, Net Entry and Exit, Actual versus Perceived location, and encryption methods. The NATO STANAG 5602 "Standard Interface for Multiple Platform Link Evaluation" (SIMPLE) Link-16 standard is one such protocol. SIMPLE address not only Link-16 but all other Tactical Data Links. While SIMPLE is based on DIS, it was originally intended to test Link-16 terminal connections. That use has been expanded to include Link-16 training, and as such, does not adequately model some Link-16 network parameters. The SISO Link-16 standard addresses this in DIS using Transmitter and Signal PDUs, and HLA under the BOM and RPR FOM paradigms;
- In use for 2 years by the U.S. Air Force, Navy, and Marines for distributed simulation training;
- The main objective of the SISO-J protocol is to establish a standard for Link-16 message exchange and JTIDS network simulation in the DIS and HLA interoperability paradigms. The intent is to prescribe the content of the standard fields of the Transmitter and Signal PDUs (and the corresponding HLA RPR-FOM Transmitter Object and Signal Interaction) and establish procedures for their use. Compliance with these procedures will facilitate interoperability among Link-16 simulation systems;
- Is in use in NATO and partner countries; and
- This standard applies only to Link-16/JTIDS/MIDS. It does not address Link-16 over SATCOM.

2.4.8 JREAP

The NATO Modelling and Simulation Standards Profile does not include the JREAP (Joint Range Extension Applications Protocol MIL-STD-3011) standard. JREAP extends the range of

Tactical Digital Information Link by permitting tactical data messages to be transmitted over long-distance networks. According to Wikipedia [Wikipedia]:

- JREAP was developed due to the need to communicate data over long distances without degradation to the message format or content. JREAP takes the message from the format it was originally formatted in and changes the protocol so that the message can be transmitted over Beyond Line-of Sight media;
- JREAP is the protocol and message structure for the transmission and reception of pre-formatted messages over communications media other than those for which these messages were designed;
- JREAP provides a foundation for Joint Range Extension (JRE) of Link-16 and other tactical data links to overcome the line-of-sight limitations of radio terminals such as the Joint Tactical Information Distribution System (JTIDS) and Multi-functional Information Distribution System (MIDS), and extends coverage of these data links through the use of long-haul media;
- JREAP-A is an encrypted satellite link using a serial data interface to exchange information in a half-duplex or broadcast mode;
- JREAP-B is a secure synchronous or asynchronous point-to-point serial data interface used to exchange information in a full-duplex data-transparent mode; and
- JREAP-C is a secure data link interface that encapsulates JREAP over IP using IP based networks for the exchange of information.

2.5 The Synthetic Range Interoperability Model

A *Synthetic Range Interoperability Model* simplifies the development of a synthetic range architecture and thus the integration of participating Synthetic Range compliant, LVC systems.

An appropriate set of ADF corporate, synthetic range, interoperability standards is being developed to enhance capability and reduce risk and cost. Once such a set of Synthetic Range Interoperability Model standards has been developed, a set of complementary test and acceptance procedures can also be developed [Ross].

The synthetic range interoperability model (Figures 1) addresses interoperability from three points of view:

- Advanced Distributed Simulation interoperability;
- Tactical Data Link interoperability; and
- Radio Communications interoperability.

The Synthetic Range Interoperability Model simplifies understanding how military LVC systems can interoperate. The Synthetic Range Interoperability Model can be used as a tool to

simplify (i.e. assist in) the understanding and development of an appropriate Synthetic Range architecture.

An alternative tabular method of presenting the information shown in Figure 2 is shown in Table 3.

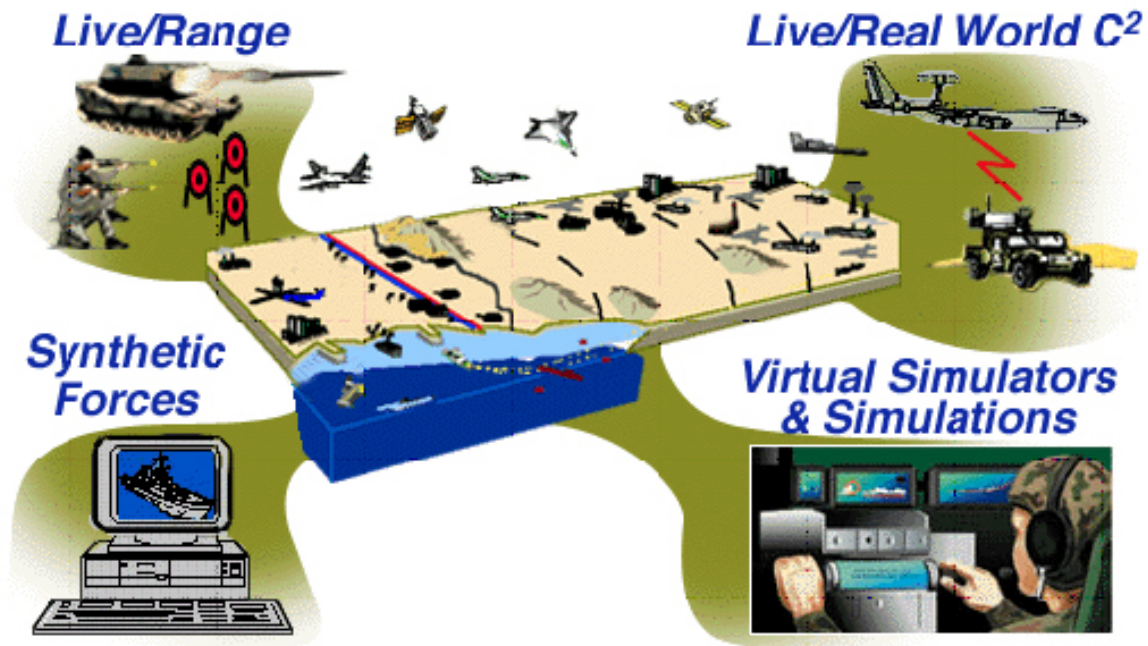

Figure 1 A Graphic of an LVC Synthetic Environment

Sharing a common scenario (i.e. the Ground Truth) on an advanced distributed simulation network in a Synthetic Environment will reduce costs considerably by not requiring real operational platforms for every entity in a common scenario. The potential of this approach was demonstrated in Australia in 2007 with LVC participants from the US and ADF participating in Exercise Talisman Sabre 07. Further savings may be achieved by building distributed (and re-usable) system capability and functionality using smaller (but more dedicated) distributed simulation applications rather than creating a single large LVC software system. The DSTO developed Air Defence Ground Environment Simulator (ADGESIM) RAAF trainer uses such a distributed architecture and the ADGESIM applications can be reused in other DIS simulation systems.

Supporting real Tactical Data Links realistically simulates the real world NCW environment and enhances the fidelity and capabilities of Synthetic Range multi-player, multiple site exercises.

Voice communication is the common variable tying LVC entities together regardless of the operating domain – it is a basic component of the synthetic battle space [Rumpel].

Note that the architecture / interoperability model (Figure 2 and Table 3) is a *minimum* starting point - it does not preclude later enhancement of the current components or addition of other new components to the model (i.e. the ADF model) or to a specific (i.e. RAN) version of the model.

The long term research and development objectives of the Synthetic Range are to:

- Further develop the Concept of the Synthetic Range;
- Develop more complete corporate (i.e. recommended ADF) Synthetic Range Interoperability Model interoperability standards; and
- Ensure (through Australian Defence Simulation Office / Defence Materiel Organisation participation) that every LVC system that may need to interoperate is acquired with a set of Synthetic Range Interoperability Model capabilities (i.e. Gateways/capabilities) that support the same set of corporate interoperability standards to enable a common level of LVC interoperability at the time of “out-the-box” system delivery and acceptance by the ADF.

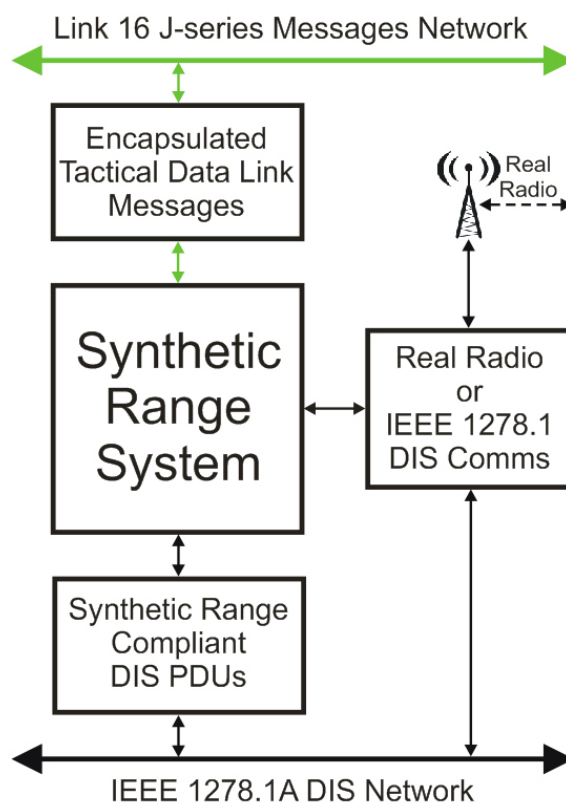

Figure 2 The Synthetic Range Interoperability Model

Although US Department of Defense (DoD) Distributed Test Events (DTEs) do not view or apply the concept of the Synthetic Range Interoperability Model in exactly the same way as shown in Figure 2 they have built a similar synthetic environment (range) architecture for the latest US DoD Joint series of exercises of interest reported in the literature - the 2005 Multi-Service Distributed Environment (MSDE) Distributed Test Event 5 (DTE 5) [O'Connor (2006)].

From Table 4, DTE 4 (2004) was a single Service exercise (only US Army systems were involved), only supported the Distributed Interactive Simulation (DIS) and High Level Architecture (HLA) advanced distributed simulation protocols, was unclassified, and had no voice communications or tactical data link capabilities.

A more advanced DTE 5 (2005) was Joint (US Army, USAF, and USN), supported DIS, HLA and TENA (Test and Training Enabling Architecture) protocols, was classified, and supported radio communications and Link-16 capabilities.

In fact the architecture and technologies supported in DTE 5 are very similar (probably identical in the cases of the USAF and USN) to the architecture and technologies supported in the Concept of the Synthetic Range, including the Synthetic Range Interoperability Model, all running on a classified network infrastructure. The architectures and technologies used are compared and discussed in more detail in section 4.

Table 3 Tabular Description of the Synthetic Range Interoperability Model Shown in Figure 2

LVC Synthetic Range Interoperability Model
ADS: DIS – IEEE 1278.1/A
Radio Communications : DIS – IEEE 1278.1 Real Radio
Tactical Data Link : Link-16 A Standard Link-16 Transport Protocol

The interoperability standards (i.e. the Synthetic Range Interoperability Models) used during the DTE4 and DTE5 set of exercises are shown in Table 5. These are presented in more detail (and broken down by US Service) in section 4.

Table 4 DTE Interoperability Model Changes Between DTE 4 (2004) and DTE 5 (2005)

DTE 4	DTE 5
Army	US Army, USN and USAF
DIS and HLA	DIS, HLA, TENA and SIMPLE
DTE FOM, Mak RTI	DTE FOM and MATREX FOM MaK RTI and MATREX RTI
Unclassified	Classified (Secret ?)
No Voice communications	Radio / Voice Communications
Tactical Data Link : No (?)	Tactical Data Link : Link-16 (SIMPLE, SISO-J)
FBCB2	FBCB2, Link-16, WMI

2.6 Section Summary

Section 2 has introduced and discussed:

- The Concept of the Synthetic Range – what is it;
- Live, Virtual and Constructive Synthetic Range (i.e. Synthetic Environment) systems – what are they and how do they differ;
- The Synthetic Range Interoperability Model - what is it, how it is used and how Distributed Simulation systems can be analysed from the three fundamental points of view to show what interoperability standards are used;
- Which Synthetic Range interoperability standards need to be considered such as DIS, HLA, SISO-J, etc.; and
- The US DTE 4 and DTE 5 exercises - these Distributed Test Event exercises have been used to demonstrate an initial application of the Synthetic Range Interoperability Model to compare what interoperability standards were used in DTE 4 and DTE 5.

3. ADF Corporate Interoperability Standards

There are currently no formal corporate interoperability standards for ADF LVC systems. Without such appropriately specified corporate interoperability standards ADF LVC systems may be acquired with interoperability capabilities but may not be able to interoperate with each other.

Once synthetic range compliant, ADF corporate, LVC interoperability standards have been developed such standards can provide guidance to acquisition projects so that LVC interoperability capabilities can be appropriately (i.e. unambiguously) specified in Government RFT contracts.

A set of such corporate LVC interoperability standards should be recommended or mandated for every newly acquired ADF system and (where technically and financially appropriate) for existing legacy systems that may require LVC interoperability. Newly acquired LVC systems that are compliant with these ADF corporate interoperability standards should be able to interoperate with each other (in Joint or coalition LVC training exercises) as soon as they have been delivered and accepted by the ADF.

Where such new systems do not comply exactly appropriate gateways can (or should) be procured as part of the original system acquisition.

Test and acceptance procedures for the distributed simulation (DIS) component of the Synthetic Range Interoperability Model have already been investigated by DSTO [Ross].

Table 5 DTE 4 (2004) and DTE 5 (2005) Synthetic Range Interoperability Models

DTE 4	DTE 5
Services : US Army	Services : US Army USN USAF
ADS: DIS HLA - DTE FOM, MaK RTI	ADS: DIS HLA - DTE FOM MaK RTI - MATREX FOM MATREX RTI TENA
Radio Communications : No	Radio Communications : DIS - ASTi DACS HLA - ASTi (Telestra ?)
Tactical Data Link : No (?)	Tactical Data Link : Link-16 (SIMPLE, SISO-J)
Security : Unclassified	Security : Classified (Secret ?)

Test and acceptance procedures for the tactical data link component of the Synthetic Range Interoperability Model should be those used by the ADF TDL Authority as it is the ADF TDL Authority that must do the testing and accreditation to enable any ADF (synthetic range compliant) LVC system to interoperate on any ADF tactical data link network.

Synthetic range compliant DIS radio/intercom communications interoperability test and acceptance procedures will still need to be developed.

Other ADF Corporate LVC interoperability standards will flow on from an initial set of interoperability standards saving more cost and reducing risk further for the ADF. Additional interoperability standards, such as an ADF "Standard Entity Set", should be developed and added to components covered by the (ADF Corporate) Synthetic Range Interoperability Model.

Once an ADF standard Entity Set has been developed, other associated standards (entity visual and behavioural models, emission and terrain databases, etc.) should/can also be developed. A draft ADF Standard Entity Set has been developed that should be "*acquired*" with every interoperable ADF LVC system [Zalcmann (2007)].

The more corporate interoperability standards are used, the less LVC simulation systems will need to be modified after they have been acquired thereby increasing "out-the-box" interoperability, and reducing risk and cost to the ADF.

If synthetic range interoperability (including appropriate gateways) is not acquired with the original system, additional justification, funding and acquisition processes will be required. This could delay synthetic range (i.e. LVC) interoperability for a system therefore reducing available capability to the ADF for years - perhaps forever.

The Synthetic Range Interoperability Model needs to be addressed from three points of view:

- Advanced Distributed Simulation interoperability;
- Tactical Data Link interoperability; and
- Radio Communications / Intercom interoperability.

3.1 Advanced Distributed Simulation Interoperability

Synthetic range participants can use Distributed Interactive Simulation [DIS (1995)], [DIS (1998)], High Level Architecture [HLA (2000) - 1], [HLA (2000) - 2], [HLA (2000) - 3], [HLA (2003)], or the Test and Training Enabling Architecture (TENA) [TENA] distributed simulation protocols to provide Advanced Distributed Simulation (ADS) interoperability between LVC systems. An ADF Corporate LVC Synthetic Range Interoperability Model (i.e. set of interoperability standards) should (i.e. must) be able to accommodate all these advanced distributed simulation protocols.

However DIS is recommended as the simulation protocol of choice (certainly for the RAAF) between federations because:

- Most ADF Advance Distributed Simulation systems use the IEEE Distributed Interactive Simulation 1278.1/A standard;
- DIS is widely used by Australia's main coalition partner - the USA [Berry], [Gresche], [Zalcman (2004) - 1], [Zalcman (2004) - 2] (see section 4);
- The USAF and USN have standardised on DIS for distributed simulation, tactical data link and voice interoperability for various components of their LVC systems [Liebert], [O'Connor (2006)] (see section 4);
- HLA systems may be more flexible however such systems have their own unique, additional (inter-federation) interoperability problems [Tudor];
- TENA is a developing technology and is rarely used in the ADF; and
- An appropriate design of these synthetic range interoperability standards can and should enable (external) interoperability between DIS, HLA and TENA systems (i.e. federations) using cost-effective, Commercial-Off-The-Shelf (COTS) gateways.

For external interoperability (between federations or LVC systems) only standard (i.e. no experimental) IEEE DIS PDUs are recommended.

Therefore for HLA, HLA Federation Object Models (FOMs) based on the HLA Real-Time Platform Reference Federation Object Model (RPR-FOM) [RPR-FOM] can be supported. Similarly for the HLA RPR-FOM equivalent TENA Logical Range Object Model can be supported. Therefore the Synthetic Range Interoperability Model is distributed simulation protocol independent - it supports DIS, HLA and TENA interoperability through the use of the RPR-FOM. Because only IEEE 1278.1/1A standard PDUs are specified in the interoperability standard (i.e. no experimental PDUs), interoperability between such Synthetic Range Interoperability Model compliant DIS, HLA, or TENA systems, should be able to be achieved using cost effective, Commercial-Off-The-Shelf (COTS) or Government-Off-The-Shelf (GOTS) gateways and software development toolkits [MaK].

A *minimum* (i.e. starting) standard set of DIS PDUs (the distributed simulation protocol part of the Synthetic Range Interoperability Model) for any ADF LVC system (with radio communications, sensors and weapons) has been developed [Zalcman (2004) - 1], [Zalcman (2004) - 2].

Such an initial, corporate (i.e. ADF) interoperability standard could be refined according to the more specific requirements of any particular service. For example every major Navy platform would most likely require an underwater acoustic capability which is unlikely to be required by most Army or Air Force platforms. Therefore the Underwater Acoustic DIS PDU (or its HLA or TENA equivalent) would be part of a RAN Synthetic Range Interoperability Model but not part of the ADF, Army or Air Force interoperability standard.

This does not mean that the Underwater Acoustic DIS PDU cannot be specified or used for an Army or Air Force LVC system (e.g. an AP-3C system) it just means that the Underwater Acoustic DIS PDU is not part of a recommended corporate ADF, RAAF or Australian Army interoperability standard.

3.2 Tactical Data Link Interoperability

Most major RAAF and RAN systems that have Tactical Data Link (TDL) capabilities are being acquired or modified to use Link-16. Therefore the Link-16, J-series message set is the preferred ADF (TDL) system [Filippidis (2007)]. However legacy RAN Link-11, Army VMF (Variable Message Format) and other TDL systems can interoperate using gateways (i.e. a data forwarding capability) to provide ADF wide TDL interoperability.

Synthetic range systems must be able to distribute TDL messages around the synthetic range, LVC TDL network. Therefore synthetic range, TDL interoperability compliance requires that industry standard TDL distribution/transport protocols, such as SIMPLE (Standard Interface for Multi-Platform Link Evaluation), JREAP (Joint Range Extension Application Protocol), SISO-J, etc., be supported. Particular message sets are not mandated however Link-16, J-series messages are recommended because the ADF is moving towards standardising on this tactical data link message set.

It is up to operational platforms and simulation systems to support the most appropriate message sets for their particular requirements. A synthetic range, tactical data link interoperability standard would be similar to

“the ability to interoperate using ADF approved, tactical data link distribution protocols, with encapsulated Link 16, J-series messages”.

The ADF Tactical Data Link Authority (ADFTA) is responsible for tactical data link testing in the ADF [ADF DI(G) OPS 42-1] to ensure tactical data link interoperability at the platform level to achieve Single, Joint and Coalition tactical data link interoperability for the ADF. For any tactical data link system (including synthetic range compliant systems) to interoperate on any ADF tactical data link network the system must comply with ADFTA tactical data link standards. Therefore synthetic range tactical data link test and evaluation procedures will be those specified by the ADFTA to accredit tactical data link systems for use by the ADF.

3.3 Radio Communications Interoperability

Previous ADF training systems (AP-3C, HMAS WATSON FFG, ANZAC team trainers, etc.) were initially delivered with proprietary internal communications sub-systems that were unable to interoperate externally using simulated radio communications or intercoms. New ADF simulation acquisitions are now being acquired with COTS DIS or HLA radio communications capabilities.

An appropriate synthetic range, communications interoperability standard would be similar to:

“the ability to interoperate using real radio communications and / or IEEE 1278.1 Radio Communications Family PDUs (or the HLA equivalent)”.

Suitable test and evaluation procedures will need to be developed to enable synthetic range radio communications systems compliance to be tested.

3.4 Section Summary

Section 3 is a more in-depth discussion and analysis of the three common interoperability components (i.e. interoperability standards) of the Synthetic Range Interoperability Model: Advanced Distributed Simulation interoperability; Tactical Data Link interoperability; and Radio communications and intercom interoperability.

The longer term objective of this work is to develop an ADF Corporate Synthetic Range Interoperability Model (i.e. a set of ADF Corporate interoperability standards) that will precisely and unambiguously define LVC interoperability parameters that will be specified when acquiring any ADF LVC system. Any such system that complies with the recommended (i.e. specified) ADF Corporate Synthetic Range Interoperability Model (i.e. a set of ADF Corporate interoperability standards) should be delivered (tested and accepted) with a useful, usable out-the-box level of LVC interoperability.

Such an ADF Corporate Synthetic Range Interoperability Model will result in reduced cost and risk to the ADF for compliant ADF LVC systems.

4. Synthetic Range Interoperability with Coalition LVC Systems

4.1 The USA Multi-Service Distributed Environment Test Event Exercises

In the US a set of Distributed Test Event (DTE) exercises are being used to develop a Multi-Service (i.e. Joint) Distributed Environment, classified network and architecture to support LVC operational and analytical requirements [Liebert].

These DTE exercises started in 2003 and the latest (reported) DTE 5 exercise was planned and executed from August 2004 to December 2005 with the actual exercise event being carried out over an approximate one week period at the end of August, 2005. The DTE 5 “system” comprised 189 US Army, Air Force and Navy LVC systems (100 unique systems) interoperating in a classified, mixed protocol architecture environment spanning across 22 networked sites [Liebert], [O’Connor (2006)].

O’Connor et al [O’Connor (2006)] indicate a successful use of a mixed-protocol architecture for joint testing (of interoperability between the mixed-protocol LVC systems) and argue that a

mixed architecture is not only feasible, but desirable, because such a mixed architecture provided the lowest cost and schedule risk for DTE 5 in the time period available for integration.

What O'Connor et al. are actually saying is that with 189 legacy systems (comprised from 100 unique systems) the easiest way (i.e. lowest cost and least risk within the time frame required) to provide interoperability between the systems was to support multiple "interoperability standards" and then bridge and gateway between these interoperability standards rather than try and get each of these 100 unique systems to comply with only one set (i.e. a corporate set) of interoperability standards.

The DTE 5 mixed-protocol simulation architecture supported the following:

- DIS, HLA (DTE and MATREX (Modeling Architecture for Technology, Requirements and Experimentation) Federations) and the TENA advanced distributed simulation protocols;
- Link-16 J-series messages using the SIMPLE [STANAG 5602] transport protocol for USN systems and the (SISO-STD-002-2006) SISO-J [SISO] transport protocol for USAF systems for tactical data link interoperability; and
- The (de-facto industry standard) ASTi [ASTi] DIS (and HLA) radio communications systems.

The DTE 5 simulation architecture [Liebert], [O'Connor (2006)] is shown in Figure 3 where only the *logical simulation architecture* and significant sources and consumers of simulation data are shown.

Although test centres use the DIS protocol locally, it cannot be broadcast across the WAN without a complex router configuration. Instead, test centres convert all DIS broadcast packets to HLA unicast packets through software gateways before transmitting them across the WAN. When a HLA packet is received by a test centre's DIS-HLA gateway, it is converted back to DIS and broadcast to the LAN [O'Connor (2004)].

HLA was the preferred DTE 5 WAN distributed simulation protocol when compared to DIS because HLA is able to be routed across the WAN without creating WAN tunnels, which was found to be time consuming and difficult to maintain in previous (DIS) exercises. However the USAF had an existing DIS based WAN and to reduce risk this was maintained [O'Connor (2006)].

The DTE 5 exercise simulation architecture would be very similar to an architecture that would be developed from the recommended ADF Corporate Synthetic Range Interoperability Model. There are however some subtle differences.

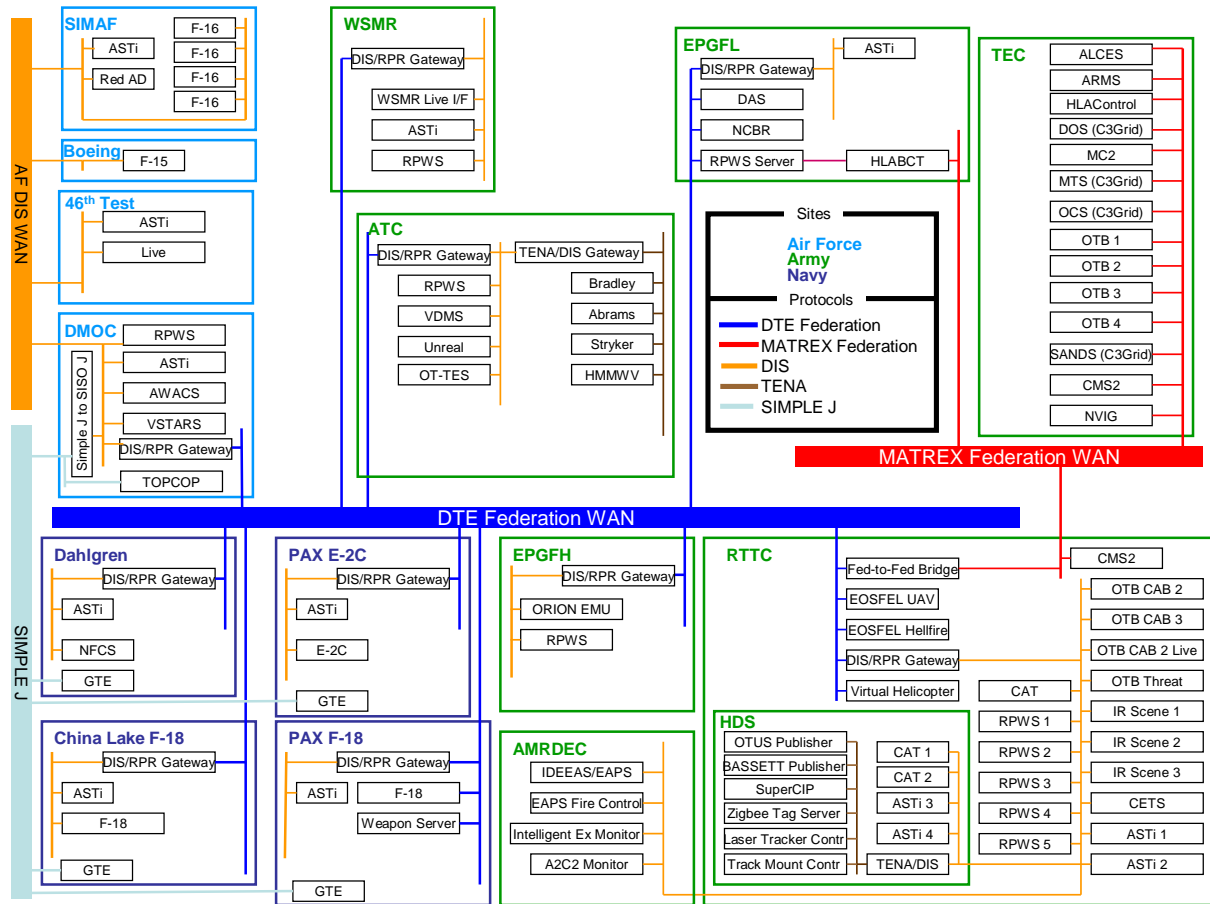

Figure 3 The US DoD DTE 5 Simulation Architecture

4.1.1 Distributed Simulation Interoperability

In DTE 5 advanced distributed simulation interoperability was required between DIS, HLA and TENA LVC systems.

DTE 5 TENA systems interoperated with other DTE 5 systems via a DIS/TENA Gateway.

In DTE 5 two HLA Federations (the DTE Federation and the MATREX Federation) were supported. The DTE Federation HLA FOM is based on the RPR-FOM version 1 (IEEE 1278.1 equivalent) standard plus some additional RPR-FOM Version 2 classes/objects (i.e. HLA equivalent of IEEE 1278.1/A specific PDUs). The DTE Federation used the MaK Run Time Infrastructure (RTI). The MATREX Federation used the US Defense Modeling and Simulation Organisation (DMSO) NG 1.3 RTI and the MATREX FOM was based on the Future Combat Systems FOM. A prototype MaK Technologies federation-to-federation bridge (possibly VR-Exchange) was used to bridge data and provide interoperability between the DTE and MATREX HLA Federations.

In the Synthetic Range Interoperability Model the DIS PDUs specified are based on the IEEE 1278.1/A standard therefore the industry standard HLA RPR-FOM version 2 would be the Synthetic Range Interoperability Model standard HLA FOM used. All ADF Synthetic Range HLA systems would be based on the version 2 RPR-FOM and only simple federation-to-federation COTS or GOTS bridging products should be required.

Because Synthetic Range DIS systems are based on the IEEE 1278.1/A standard and because Synthetic Range HLA systems would use the RPR-FOM version 2, a cost-effective COTS (or GOTS) DIS/HLA Gateway product, that supported all the required DIS/HLA components, could gateway between Synthetic Range compliant DIS and HLA systems.

4.1.2 Tactical Data Link Interoperability

O'Connor et al. state that an objective of DTE 5 was to use a simple, single HLA system (RTI, FOM, etc.) to provide interoperability over the DTE 5 WAN between Federations. According to O'Connor et al, one of the reasons that this was not achieved was that there was no existing tool to convert the SIMPLE tactical data link transport protocol used by the USN to HLA at the time the DTE 5 exercise was carried out [O'Connor (2006)].

Appropriate tools are now available that would simplify the DTE 5 WAN architecture further. The Northrop Grumman Gateway Manager can act as a gateway between the STANAG 5602 SIMPLE and the (DIS but not HLA) SISO-STD-002-2006 (SISO-J) tactical data link transport protocols. A COTS (or GOTS) DIS/HLA Gateway could then convert the SISO-STD-002-2006 or SISO-J DIS Transmitter and Signal PDUs to their HLA (RPR-FOM 2) equivalent.

4.1.3 Radio / Voice Communications Interoperability

From Figure 3 DTE 5 systems with radio/voice communications capabilities used ASTi DIS (i.e. DACS) systems. Some DTE 5 HLA radio/voice communications must have been used as O'Connor et al reported interoperability problems between systems using DIS Signal PDUs and HLA RPR-FOM RadioSignal.RawBinaryRadioSignal interactions [O'Connor (2006)].

The Synthetic Range Interoperability Model supports IEEE 1278.1 DIS radio/voice communications (and its RPR-FOM HLA equivalent) so Synthetic Range and DTE 5 compliant radio/voice communications systems should be interoperable.

The DTE 5 papers ([O'Connor (2006)] and [Liebert]) specifically discuss LVC radio communications interoperability (i.e. interoperability between real radio and simulation radio systems) therefore a COTS or GOTS gateway between real radio systems and distributed simulation voice/intercom systems (such as the ASTi [ASTi] Synapse system) must have been available to DTE 5 systems.

4.2 Synthetic Range Interoperability with USAF (DTE 5) DMOC Systems

An analysis using the various components of the Synthetic Range Interoperability Model can be used to discuss the degree of interoperability that should be able to be achieved between ADF Synthetic Range Interoperability Model compliant systems and the various US DoD DTE 5 LVC Service systems.

4.2.1 Advanced Distributed Simulation Interoperability

All DTE 5 USAF Distributed Mission Operations Center (DMOC) systems used the IEEE 1278.1/A DIS protocol. Interoperability between these DIS systems and the DTE 5 HLA systems was achieved using relevant DIS/HLA (RPR-FOM) Gateway products.

The DMOC LANs consist of a common LAN (where all DIS data resides), and separate LANs for each DMOC simulator and LANs to each USAF external site. To protect DMOC simulation systems from excess PDUs, data required for every DMOC site was filtered using the USAF DIS Filter/Analyser (DFA) device [Szulinski], [Sorroche], [Padilla (2007)] to:

- Block PDUs that are not required externally or are not handled adequately;
- Limit bandwidth on a WAN; or to
- Perform translations between systems with incompatible implementations of the relevant DIS standard;

These USAF DIS Filter/Analyser (DFA) devices (see Figure 4) only transmitted data that are required by each individual DMOC system [Szulinski], [Sorroche], [Padilla (2007)].

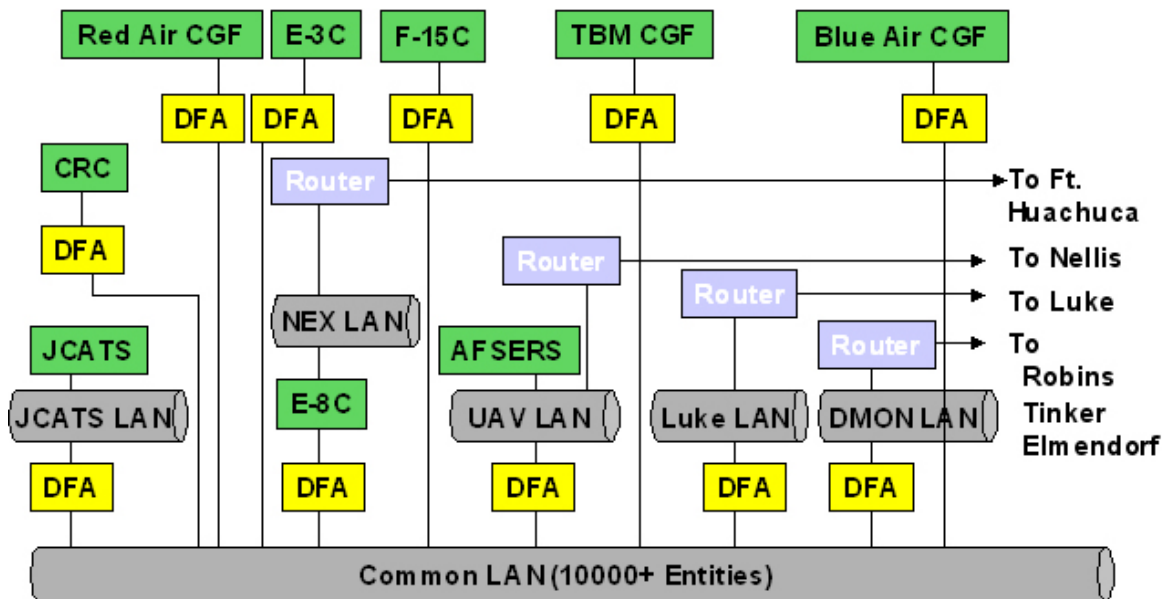

Figure 4 DMOC Common LAN Configuration

Therefore the DFA's only allow DIS PDUs through the filtering device that are of importance, that is, **only DIS PDUs that** are in the USAF corporate interoperability standard (i.e. **should also be in our (ADF corporate) interoperability standard**) are filtered through.

The example USAF DFA GUI image (Figure 5) actually shows the IEEE 1278.1/A DIS PDUs of importance which are the:

- **Entity State PDU;**
- **Fire PDU;**
- **Detonation PDU;**
- **IFF (Identify Friend or Foe) PDU;**
- **Electromagnetic Emission PDU;**
- **Transmitter PDU;** and the
- **Signal PDU.**

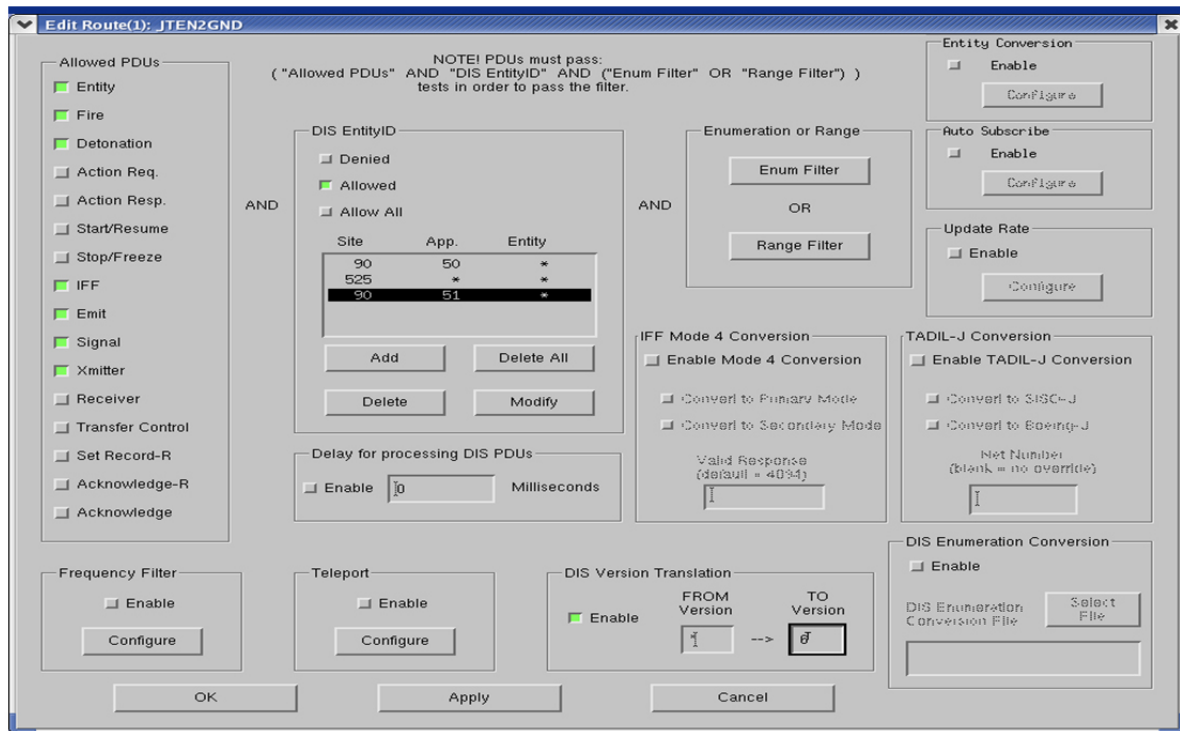

Figure 5 USAF DIS Filter / Analyser GUI Image

These are the IEEE 1278.1/A DIS PDUs that will need to be supported in the (minimum) ADF Corporate Synthetic Range Interoperability Model

The Receiver PDU is rarely used and the Transfer Control PDU would not be included in an ADF corporate interoperability standard because it would only be of use to specific systems that would require such a capability such as some air-to-ground missiles.

These IEEE 1278.1/A DIS PDUs that are required by the USAF simulation systems (that are shown above) are very similar (i.e. probably identical) to the IEEE 1278.1/1A DIS PDUs included in the recommended ADF Corporate Synthetic Range Interoperability Model. Therefore a Synthetic Range Interoperability Model compliant system should be highly interoperable with USAF DMOC simulation systems.

Synthetic Range Interoperability Model compliant systems would simply need to connect their 1278.1/A distributed simulation systems to the **DTE 5 AF DIS WAN** to establish distributed simulation systems interoperability where the **DTE 5 AF DIS WAN** text shading colour coincides with the DTE 5 network colour shading shown in Figure 3.

Because the DTE 5 DMOC systems were made highly interoperable with the DTE 5 US Army and USN systems it can then be assumed that Synthetic Range Interoperability Model compliant systems will also be highly interoperable with US Army, Navy and Air Force DTE 5 systems; however gateways (similar to those used in DTE 5) would be required.

4.2.2 Tactical Data Link Interoperability

USAF DMOC simulation systems use the SISO-J tactical data link standard [SISO] where Link-16 J-series messages are encapsulated and transported around the network within the IEEE 1278.1 DIS Transmitter and Signal PDUs (see Figure 6).

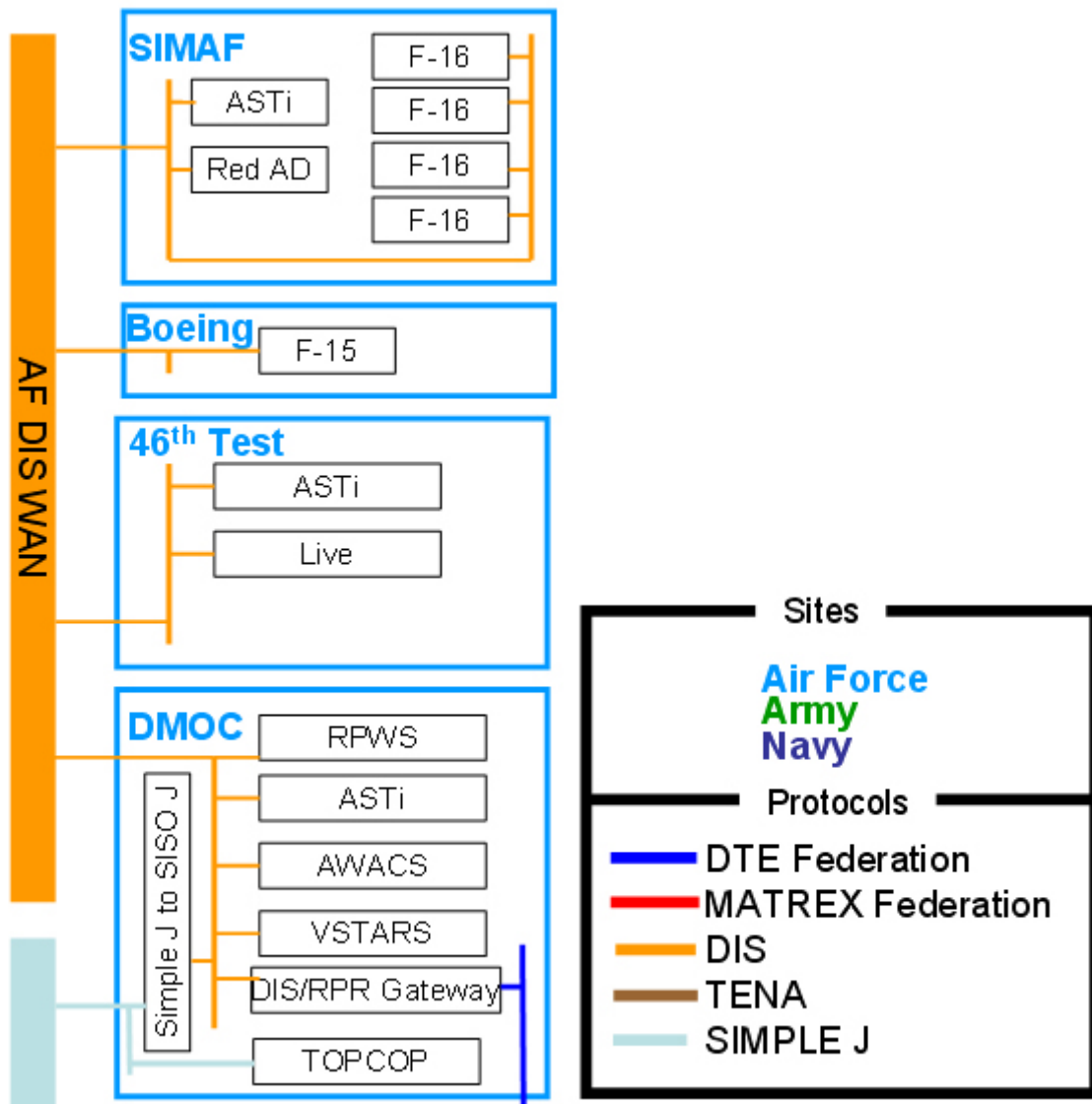

Figure 6 USAF Simulation Systems and Protocols Used in the DTE 5 Event

However there are some legacy USAF simulators that use a proprietary, non-standard, Boeing developed Signal PDU (TACCSF-J or TACCSF DIS format [O'Connor (2006)], [Padilla (2007)]) to provide Link-16 interoperability. Either the USAF DIS Filter/Analyser device [O'Connor

(2006)], [Padilla (2007)] or a Northrop Grumman CCD [Szulinski] (or Gateway Manager) device can be used to bridge and provide interoperability between the proprietary Boeing TACCSF DIS Signal PDUs and standard IEEE 1278.1 Signal PDUs.

The USAF Distributed Mission Operations Center tactical data link SIMPLE J to SISO-J Gateways (Figures 3 and 6) are (Northrop Grumman) CCD devices [O'Connor (2006)]. Therefore Synthetic Range Interoperability Model compliant systems that would need to connect to the **DTE 5 SIMPLE J WAN** (i.e. RAN LVC systems) could use a COTS Northrop Grumman Gateway Manager (the Gateway Manager supersedes the CCD) to establish Link-16, J-series messages interoperability.

4.2.3 Radio Communications Interoperability

From Figure 3 DTE 5 systems appear to have standardised on ASTi DIS (IEEE 1278.1) radio communications systems which would be completely interoperable with the radio communications component of the Synthetic Range Interoperability Model. Therefore Synthetic Range Interoperability Model compliant systems would simply need to connect their 1278.1 DIS voice communications systems to the DTE 5 AF DIS WAN to establish voice communications systems interoperability.

4.2.4 The US Air Force DMO Synthetic Range Interoperability Model

It is clear that USAF simulation systems are *DIS compliant* systems where the USAF DTE5 Synthetic Range Interoperability Model can be viewed or defined as:

- Advanced Distributed Simulation Interoperability: DIS where the main PDUs (not including Management and Handshake/Control PDUs) would include the Entity State, Fire, Detonation, IFF, Electromagnetic Emission, Transmitter, Signal and Receiver PDUs (left-hand side of Figure 5);
- Tactical Data Link Interoperability; Link-16 J-series messages encapsulated within the DIS SISO-J (SISO-STD-002-2006) standard; and
- Voice Communications: ASTi DIS (i.e. DACS) radio/voice communications systems.

The DIS PDUs in the shaded box above basically define an initial ADF Synthetic Range Interoperability Model (at the PDU level).

Padilla et al. [Padilla (2008)] state

“The types of simulation data that the USAF DMOC Replay Tool (DRT) processes from a DIS network include the following:

- Entity dynamics from the Entity State PDU network packet;
- Entity engagements from the Fire and Detonation PDUs;
- Radar tracking and targeting from the Electromagnetic Emission PDU;

- Identification Friend or Foe (IFF) capability with the IFF PDU;
- DIS simulated radio voice using the Transmitter, Signal and Receiver PDUs; and
- DIS simulated Tactical Data Links using the Transmitter and Signal PDUs.”

Therefore the USAF DMOC (DTE 5) simulation systems should be highly interoperable with any LVC system that is compliant with the recommended ADF corporate, Synthetic Range Interoperability Model. The tabular form of the USAF Synthetic Range Interoperability Model is shown in Table 6.

Table 6 USAF Synthetic Range Interoperability Model from DTE 5

US Air Force
ADS: DIS – Entity State PDU Fire PDU Detonation PDU Electromagnetic Emission PDU IFF PDU
Radio Communications : DIS - ASTi DACS <div style="text-align: right;">Transmitter PDU</div> <div style="text-align: right;">Signal PDU</div> <div style="text-align: right;">Receiver PDU</div>
Tactical Data Link : Link-16 Tactical Data Link Transport Protocol : SISO-J

4.3 Synthetic Range Interoperability with USN (DTE 5) Systems

An analysis of DIS PDUs recorded during four RAN/USN coalition demonstration exercises carried out at the HMAS Watson MWTC in 2001 and 2003 between the RAN and USN is shown in Table 7 [Zalcman (2004) - 1], [Zalcman (2004) - 2]. Some PDU traffic may have been filtered out at the US end of the WAN connection between the USA and HMAS Watson however all the DIS traffic reported in table 7 would have been present on both the RAN and

USN LVC networks. The recommended, minimum basic set of DIS PDUs [Zalcman (2004) - 1], [Zalcman (2004) - 2] is shown in the shaded cells in Table 7.

The data shown in Table 7 supports the concept of the *minimum* corporate interoperability standard set of PDUs because:

- The vast majority of the PDUs (99.25% for the Sept 03/1 exercise, 99.46% for the Sept 03/2 exercise, 99.9% for Feb 03 exercise, and 97.2% for Nov 01 exercise) for each exercise are contained within the recommended (ADF) corporate Synthetic Range Interoperability Model PDU set;
- The remaining Underwater Acoustic (UA) PDU and the BFTT Experimental PDUs (the BFTT Supplemental Electromagnetic Emission (BSEE) PDUs and the BFTT Multiphase Electromagnetic Emission (BMEE) PDUs) would not be included in the minimum ADF corporate interoperability standard set of PDUs as these PDUs are unlikely to be required by most ADF DIS simulation systems where:
 - The Underwater Acoustic PDU (which would be included in a RAN corporate interoperability standard) only accounts for a very minor part (a maximum of 0.05%) of the total number of PDUs; and
 - The experimental PDUs account for between 0.5% and 2.8% of the total number of PDUs in the various exercises.

In recent 2006 RAN/USN Coalition Fleet Synthetic Training (CFST) exercises, HMAS WATSON RAN team training systems interoperated with real (i.e. Live) USN BFTT system ships using an interoperability model that was almost identical to the recommended ADF Synthetic Range Interoperability Model [Clark (2006)]. CFST interoperability occurred using DIS and HLA distributed simulation protocols, Link-11 and Link-16 tactical data link messages, the SIMPLE tactical Data link transport protocol, and DIS and VoIP voice/intercom communications protocols.

Table 7 Number of DIS PDUs for four RAN/USN Coalition Exercises (where ES indicates Entity State PDU, EE indicates Electromagnetic Emission PDU, TX indicates Transmitter PDU, RX indicates Receiver PDU, UA indicates Underwater Acoustics PDU, SM indicates Simulation Management PDUs, BSEE indicates Experimental BFTT Supplemental Electromagnetic Emission PDU and BMEE indicates Experimental Multiphase Electromagnetic Emission PDU).

PDU Type	ES	FIRE	DET	SM	EE	TX	SIG	RX	IFF	UA	BSEE	BMEE	TOTAL
Sept 03 / 1	441,372	0	0	7,072	41,694	106,058	826,103	92,844	56,064	862	3,729	7,246	1,583,044
%	27.88%	0.00%	0.00%	0.45%	2.63%	6.70%	52.18%	5.86%	3.54%	0.05%	0.24%	0.46%	
Sept 03 / 2	625,509	10	10	4,343	47,577	202,598	964,020	111,490	72,591	778	3,723	7,371	2,040,020
%	30.66%	0.00%	0.00%	0.21%	2.33%	9.93%	47.26%	5.47%	3.56%	0.04%	0.18%	0.36%	
Feb 03	267718	118	106	0	98045	155452	484742	183823	16364	87			1,206,455
%	22.19%	0.01%	0.01%	0.00%	8.13%	12.89%	40.18%	15.24%	1.36%	0.01%			
Nov 01	83122	10	9	514	13291	43854	185833	65970	20321		11883		424,807
%	19.57%	0.00%	0.00%	0.12%	3.13%	10.32%	43.75%	15.53%	4.78%		2.80%		

The USN DTE 5 systems are shown in Figure 7. As for the USAF systems the USN DTE 5 systems are *DIS compliant* systems. The USN DTE 5 Synthetic Range Interoperability Model can be viewed or defined as:

- Advanced Distributed Simulation Interoperability: DIS where the main PDUs would include the Entity State, Fire, Detonation, IFF, Electromagnetic Emission, Transmitter, Signal and Receiver PDUs (from Table 7);
- Tactical Data Link Interoperability; Link-16 J-series messages using the NATO STANAG 5602 SIMPLE transport protocol standard (Figure 7); and
- Voice Communications: ASTi DIS (i.e. DACS) radio communications systems (Figure 7).

Therefore the USAF DMOC (DTE 5) simulation systems should be highly interoperable with any ADF Synthetic Range Interoperability Model compliant system.

The USN Synthetic Range Interoperability Model is shown in tabular form in Table 8.

4.4 The US Army DTE 5 Interoperability Model

From Figure 8 (derived from Figure 3) the US Army Synthetic Range Interoperability Model could be viewed or defined to include:

- Advanced Distributed Simulation Interoperability: a mixture of DIS, HLA and TENA distributed simulation protocols;
- Tactical Data Link Interoperability: no support for tactical data link; and
- Voice Communications: ASTi DIS (i.e. DACS) radio/voice communications systems.

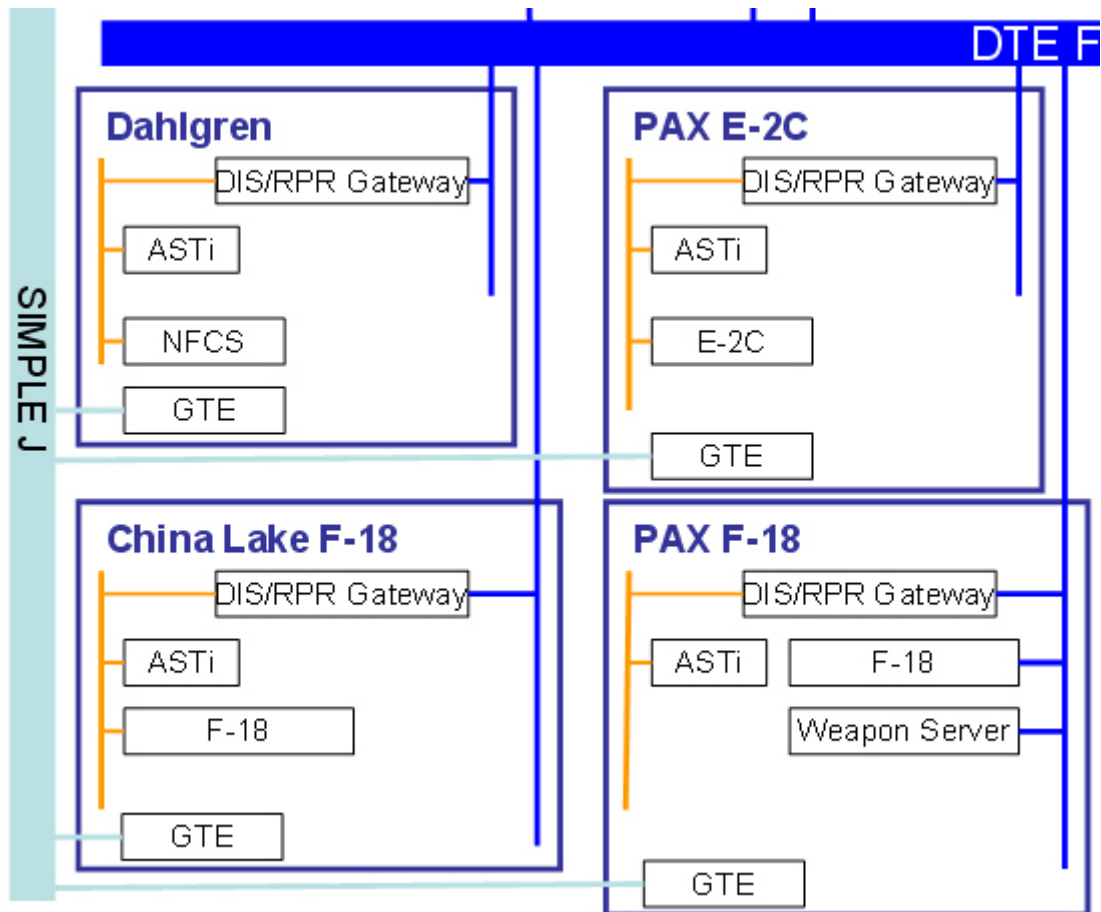

Figure 7 USN Simulation Systems and Protocols Used in the DTE 5 Event

The DTE 5 US Army Synthetic Range Interoperability Model is shown in Table 9.

4.5 Section Summary

Section 4 is a more in-depth discussion and analysis of the three common interoperability components of the Synthetic Range Interoperability Models found in the US Service systems that participated in the US DTE 5 exercises.

This section has discussed interoperability between Synthetic Range Interoperability Model compliant LVC systems and the latest, documented USA DTE 5 LVC compliant systems.

Any LVC system that is compliant with the recommended ADF Corporate Synthetic Range Interoperability Model would most likely be highly interoperable with USAF and USN DTE 5 LVC systems from the point of view of the three components of a (i.e. any) Synthetic Range Interoperability Model: distributed simulation interoperability; tactical data link interoperability; and radio/voice communications interoperability.

Table 8 USN Synthetic Range Interoperability Model from DTE 5

US Navy
ADS: DIS – Entity State PDU Fire PDU Detonation PDU Electromagnetic Emission PDU IFF PDU
ADS : HLA – DTE FOM MaK RTI
Radio Communications : DIS - ASTi DACS <div style="text-align: right;"> Transmitter PDU Signal PDU Receiver PDU </div>
Tactical Data Link : Link-16 Tactical Data Link Transport Protocol : SIMPLE

Synthetic Range interoperability with US Army LVC systems could be achieved using gateways such as those used in the DTE 5 exercise.

O'Connor et al. [O'Connor (2006)] indicate the success of a mixed protocol architecture for joint testing where a mixed architecture is not only feasible but desirable in that a mixed architecture provided the lowest cost and schedule risk for DTE 5 in the time period available for integration.

What O'Connor et al. are actually saying is that the easiest way (i.e. lowest cost and least risk within the time frame available) to provide interoperability between 189 legacy systems was to support multiple interoperability standards and then bridge and gateway between these multiple interoperability standards.

The Synthetic Range Interoperability Model is designed to address LVC interoperability at the acquisition point (i.e. the beginning point) of the LVC system life-cycle. A set of corporate Synthetic Range interoperability standards is being developed to enable every future ADF LVC system to be delivered to, and accepted by, the ADF with a minimum (but highly useable) level of Synthetic Range interoperability. In this situation compliance with an ADF corporate (Synthetic Range Interoperability Model) interoperability standard would be the first criterion to determine whether an ADF LVC system could participate in a ADF LVC exercise. This is preferable to the DTE 5 situation where, because of the large number of legacy systems, the exact DTE 5 simulation architecture was determined by interoperability capabilities of the participating LVC systems.

The recommended ADF Corporate Synthetic Range Interoperability Model system architecture is basically identical to the DTE 5 exercise simulation architecture. There are, however, subtle differences and the ADF Synthetic Range Interoperability Model system architecture may in fact be superior to the DTE 5 simulation architecture because:

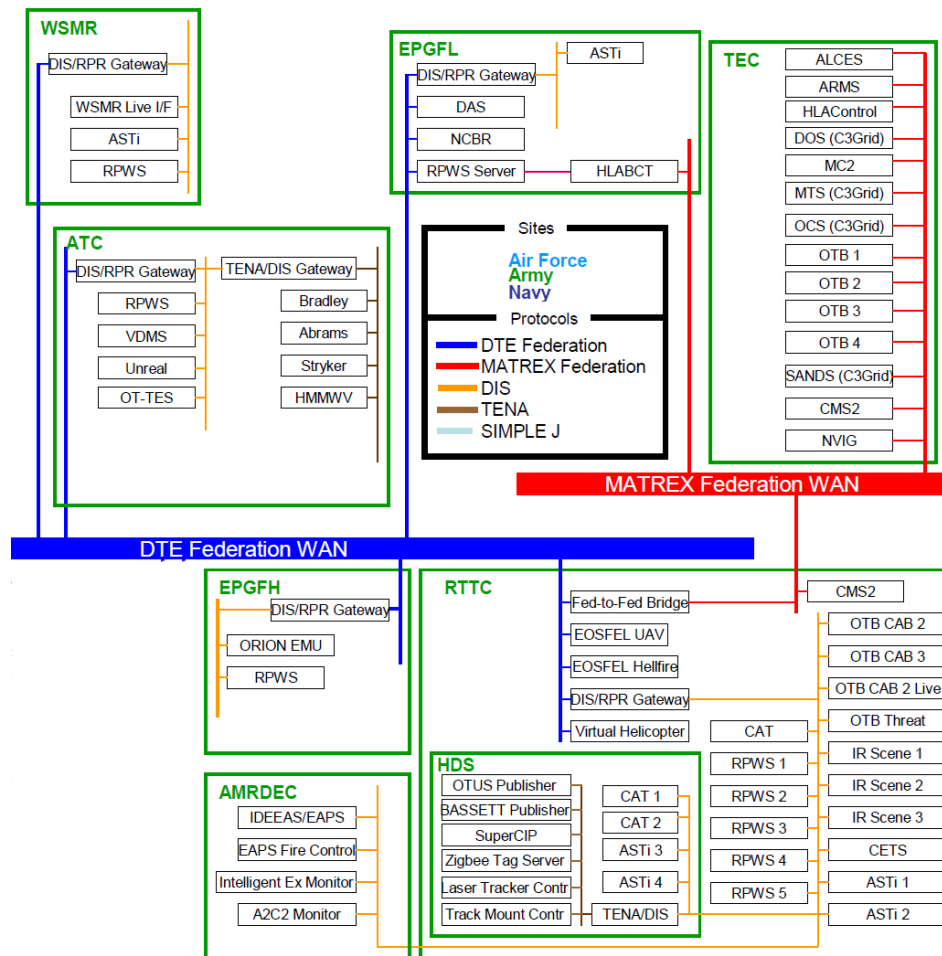

Figure 8 US Army Simulation Systems and Protocols Used in the DTE 5 Event

- Synthetic Range Distributed Simulation Interoperability is based on IEEE 1278.1/1A DIS and the equivalent RPR-FOM version 2, HLA. Different manufacturers HLA RTIs can be supported and could be bridged using COTS or GOTS federation-to-federation bridging products. DTE 5 supported two HLA Federations with different FOMs and different RTIs with its own specific set of federation-to-federation bridging problems. Synthetic Range Distributed Simulation Interoperability is simpler, has less risk and should be more cost-effective to maintain than the DTE 5 distributed simulation model because it is specified at the beginning point of the LVC system life-cycle. All ADF Synthetic Range Interoperability Model compliant systems should be highly interoperable at the time they are delivered and accepted by the ADF “out-of-the-box”;
- Synthetic Range Tactical Data Link Interoperability is based on supporting tactical data link transport protocols supported by industry standard CCD or Gateway Manager devices that are accredited by the ADF TDL Authority. Only the Gateway Manager (GM) supports more modern transport protocols such as JREAP and SISO-J therefore the GM may be more appropriate (than the superseded CCD) within a more modern tactical data link network; and

- The Synthetic Range Interoperability Model is applied at the acquisition point of the life cycle and recommends the use of COTS or GOTS bridging or gateway products. This should be the most cost-effective way to obtain interoperability between (Service and Coalition) Synthetic Range compliant LVC systems.

Table 9 US Army Synthetic Range Interoperability Model from DTE 5

US Army
ADS: DIS HLA - DTE FOM / MaK RTI MATREX FOM / MATREX RTI TENA
Radio Communications : DIS - ASTi DACS <div style="text-align: right;"> Transmitter PDU Signal PDU Receiver PDU </div>
Tactical Data Link : No

The analysis in section 4 allows us to get a better understanding of what interoperability standards are used in the US Service Synthetic Range Interoperability Models.

The DTE 5 exercises demonstrate that the US Service Synthetic Range Interoperability Models (i.e. sets of LVC interoperability standards) can be made interoperable with each other and that Australia can develop a recommended ADF Corporate Synthetic Range Interoperability Model based on the Synthetic Range Interoperability Models used by the US Services and learn from their lessons learned over more than a decade of LVC interoperability work.

5. Which Coalition Synthetic Range Interoperability Model Should the RAAF Consider?

5.1 The US Army LVC-IA Program

The US Air Force Distributed Mission Operations (DMO) Program is the USAF's attempt to provide complete integration of live, virtual, and constructive systems for training, mission rehearsal, and operations support in a theatre of war environment. DMO is the cornerstone for Air Force training transformation supporting the US DoD Strategic Plan for Training Transformation and supports Service level and Joint National Training Capability (JNTC) objectives.

The US Army has a similar effort to achieve JNTC objectives through their Live, Virtual, Constructive - Integrating Architecture and Infrastructure (LVC-IA) Program.

The LVC-IA requires standards, protocols and interfaces to link disparate Army Live instrumentation and simulation systems, Virtual simulators/simulations and Constructive simulations (i.e. US Army LVC systems) that enable Battle Command Training Capability. This also includes linking to other Service JNTC contributions such as the USAF DMO.

DMO provides the same requirement for common standards and protocols, enabling USAF LVC systems to interact in a common synthetic battlespace. "This becomes more practical as we integrate training between Joint components for recurring daily/weekly/monthly continuation training other than large-scale warfighters and exercises" [Ales].

5.2 The UK MOD MTDS Program

The UK MOD Mission Training through Distributed Simulation (MTDS) programme was developed to address an identified training gap to ensure that Royal Air Force (RAF) aircrew and other warfighters learned to operate successfully as part of a larger team. Such "collective" training has proved difficult to achieve in the Live environment except in very large and expensive exercises such as RED FLAG [Saltmarsh].

The UK MOD MTDS programme developed a RAF facility comprised of 4 fast-jet Tornado GR4 and 4 Typhoon simulators, a 7-seat AWACS mission crew training system, and an exercise management capability (including virtual role players and Computer Generated Forces (CGF) and After Action Review (AAR) facilities). In a representative Planning, Briefing and Debriefing (PBD) daily cycle, training participants performed a series of air battlespace missions with joint and multi-national collective teams in a series of events [Khetia (2009) -1], [Ludwig], [Dudfield].

The Mission Training through Distributed Simulation Capability Concept Demonstrator (MTDS CCD) programme ran from 2005 to 2008 at the Air Battlespace Training Centre (ABTC) at RAF Waddington. The programme was also developed to study various elements of

synthetic training and provide guidance for the UK MOD on technical and operational issues in implementing a distributed training program for fast-jet and other aircrew.

UK, US and Canadian forces and their military personnel from air, land and maritime services participated in the MTDS CCD events, during which their requirements for a MTDS capability were captured.

The main MTDS CCD components at RAF Waddington were comprised of:

- GR4 Tornado Simulators x 4 – based on QinetiQ's Real-Time All Vehicle Simulator (RTAVS);
- Computer Generated Forces (CGF) system – Boeing BigTAC;
- Real-time viewer/ After Action Review (AAR) / CGF tool suite – Boeing Insight;
- Radio Communications system – based on the ASTi radio system;
- Red Air role player stations – RTAVS;
- Typhoon aircraft Simulators x 4 – RTAVS;
- Airborne Warning And Control System (AWACS) Simulator – Southwest Research Institute;
- Forward Air Controller (FAC) station x 2 – Meggitt;
- CGF system – Joint Semi-Autonomous Forces (JSAF);
- CGF system – Combined Arms Tactical Trainer (CATT);
- Apache (AH) helicopter role player station – RTAVS; and
- Tactical Unmanned Air Vehicle (TUAV) role player station – RTAVS;

In addition a number of DIS applications were linked in externally over the WAN during distributed exercises from sites in the UK, US and Germany (albeit a US base in Germany). This has included connections to the US through the DMOC and DMON including:

- Apache AH-64 Simulators at Dishforth;
- UK Naval Type 42 simulator at Southwick Park (formerly HMS Dryad), UK;
- F16 & A10 Simulators at AFRL (MESA), US;
- F15 simulators at Langley, US;
- F15 & AWACS simulators at Albuquerque, US;
- A10 simulators at Spangdahlem, US airbase in Germany; and
- Joint Tactical Air Controller at AFRL (MESA), US & Defence Research and Development Canada.

According to Khetia [Khetia (2009) -1] the use of synthetic environments augments the more expensive live flight training in operational platforms. The need to provide further training in tactics and operational command and control introduced a number of equally necessary training requirements which required air crews and other forces to operate in a realistic training environment. As a result of the MTDS CCD further requirements were being identified for training with other nation's forces in Joint and Coalition operations.

The current norm for this type of training would be to develop scenarios and deploy all trainees to a central facility with all the manpower and equipment necessary to conduct a full scale exercise. With budgets being trimmed, the distributed training capability saves money by being able to train in simulators at the aircrew's home base instead of travelling to a central location. With a distributed training capability in place, the UK will in future be able to train jointly with other components of the UK Military or in a coalition event with military from the US or other coalition partners.

According to Saltmarsh [Saltmarsh] it was one of the ironies of the demonstrator program that training for Land Forces came about as an unintended consequence of the CCD program. One of the questions to be addressed by the CCD was the level of "training fodder" likely within UK MTDS. The facility was adapted to include a Forward Air Controller (FAC) station and experiments were then run to investigate the level of benefit for the FAC and the increase in benefit for other trainees. The assumption being that the FAC would be a good example of a role player who derived very little training benefit from involvement in the exercise. The actual result was in dramatic contradiction to this hypothesis. The FAC "trainee" (a FAC instructor normally) declaring this was the "best training he had received outside the live environment".

The training was not designed to teach trainees how to operate their equipment; this was taken as a pre-requisite. Instead it taught how to use the full range of equipment in a realistic operational environment to maximise the individual's effectiveness as part of a team and the wider military operation.

The MTDS CCD Synthetic Range Interoperability Model is clearly based on IEEE 1278.1/A DIS, DIS Radio Communications and Link-16 [Khetia (2009) -1], [Beattie] and interoperates with USAF DMO systems using USAF DMT interoperability standards. Voice over Internet Protocol (VoIP) was also used [Pitz].

5.3 The UK MOD Maritime Airborne Surveillance and Control Experiment System

In a recent 2007 Verification and Validation (VV&A) of Synthetic Environments paper [Read] the architecture of a UK Ministry of Defence NITEworks Maritime Airborne Surveillance and Control (MASC) experimental setup (see Figure 9) was used to discuss VV&A aspects of a modelling and simulation system.

From Figure 9 it appears that the MASC experimental architecture is highly compliant with the recommended ADF Corporate Synthetic Range Interoperability Model as well as being very similar to the architecture used by the USAF DMOC simulation systems (see Table 6).

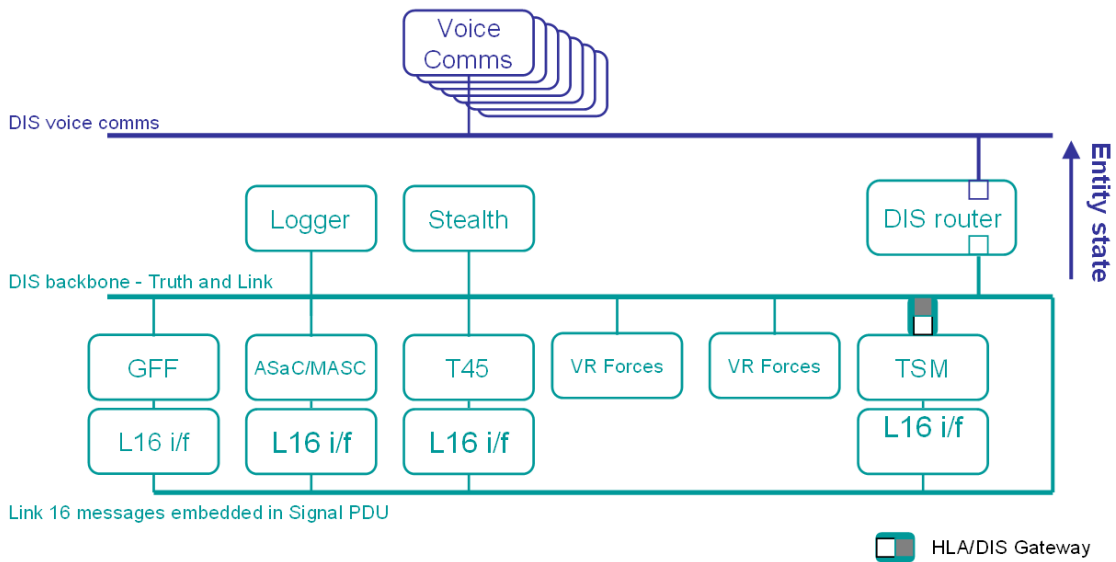

Figure 9 UK MOD Maritime Airborne Surveillance and Control Experiment Architecture

5.4 The NATO Live, Virtual and Constructive Project

Wood et al. [Wood] report research work to support the NATO Live, Virtual and Constructive Project (NLVC) which is part of Allied Command Transformation’s (ACT) Snow Leopard program. The objective of the NLVC Project is to provide a permanent NATO capability for joint mission rehearsal and training. Woods et al. report on the development of some Spanish NLVC systems where it was important to develop and validate standards and protocols to allow systems to be interoperable with NLVC.

In February 2008 a Spanish Air Force NLVC event was carried out to demonstrate the training potential between Spanish Air Combat Command operators and Virtual F-18 simulator pilots, and to validate interoperability between all the NLVC participants.

In these Spanish NLVC systems:

- The HLA RPR-FOM v2d17 (HLA equivalent of IEEE 1278.1A) was used;
- The MaK IEEE 1516 RTI was used;

- Simulated Land entities used IEEE 1278.1A DIS and joined the HLA Federation using the MaK DIS/HLA Gateway;
- Voice communications were provided verbally as a communications infrastructure was considered important; and
- TDL messages were exchanged (must be SISO-J ?) between NLVC DIS and HLA systems.

Therefore European LVC systems also seem to support an infrastructure similar to that described by the (USAF) Synthetic Range Interoperability Model.

The NATO Spanish LVC Synthetic Range Interoperability Model is shown in Table 10.

Table 10 Synthetic Range Interoperability Model for NATO LVC

NATO Spanish LVC
ADS: DIS IEEE 1278.1/A HLA IEEE 1516 FOM is based on RPR-FOM V2D17 MaK RTI
Radio Communications : Verbal
Tactical Data Link : Link-16 SISO-J (HLA and DIS)

5.5 The Norwegian Defence Research Establishment Joint Tactical Training Capability Prototype (JTTCP) System

Nielsen et al. [Nielsen] report on the Joint Air Defence Training Simulation (JADE) II experimental synthetic exercise carried out by the Norwegian Defence Research Establishment in October 2007. According to Nielsen et al. the JADE II Joint Tactical Training Capability Prototype (JTTCP) was a proof of concept demonstrator built with limited time and resources.

An overview of the JTTCP is shown in Figure 10 where: the lower and middle parts of Figure 10 show the LVC systems responsible for conveying and generating common ground truth; and the upper part of Figure 10 shows the Voice Communication and Tactical Data Link systems used for exchanging perceived truth in the form of a Recognised Air Picture [Nielsen].

From the JJTTC work we can deduce that the main interoperability components used are distributed simulation, voice communications and tactical data link interoperability where:

- The JJTTC distributed simulation protocols are a mixture of IEEE 1278.1/A DIS and IEEE 1516 RPR FOM V2 (MaK RTI) HLA using a MaK technologies DIS/HLA Gateway to translate between DIS and HLA;
- Voice over IP (VoIP) was used to support a radio communications system; and
- The Joint Range Extension Application Protocol (JREAP) and the HLA component of SISO-J Link-16 transport protocols were used to distribute Link-16 throughout the JJTTC system.

Also the conceptual view of the JJTTC shown in Figure 11 clearly indicates the use of data similar to (i.e. where the same DIS PDU data functionality is used) that discussed in section 4.

The Synthetic Range Interoperability Model used by the JJTTC system is shown in Table 11.

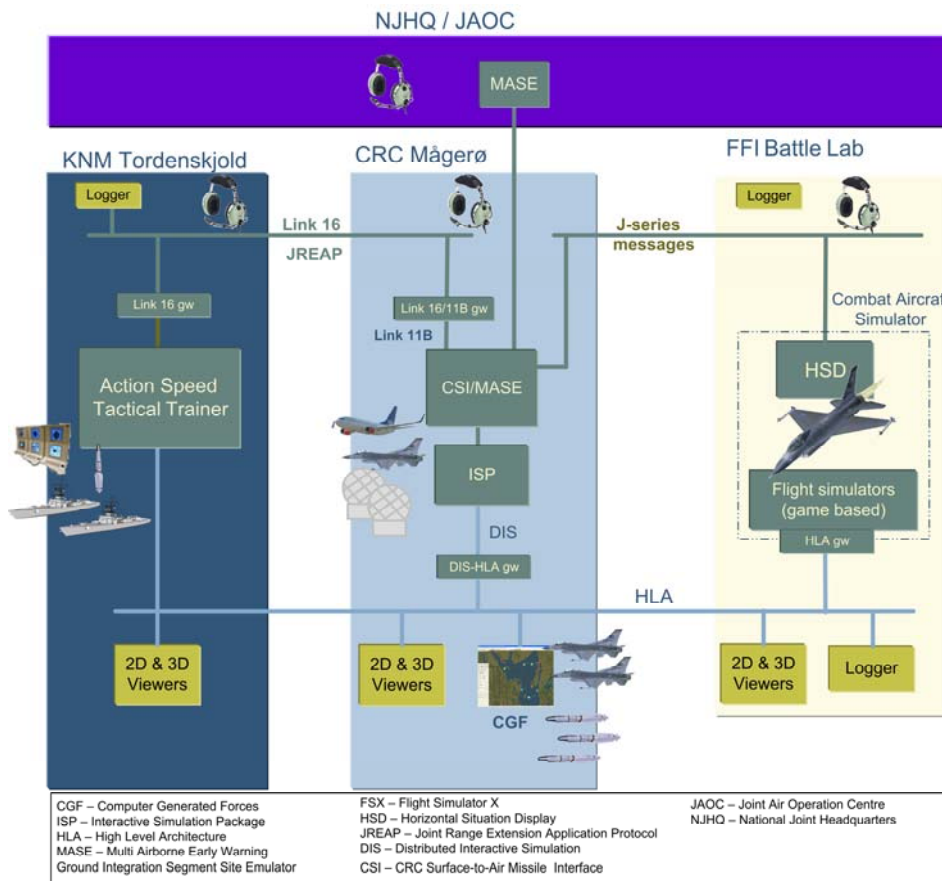

Figure 10 Overview of the JADE II Experimental Exercise Architecture

5.6 The Canadian Air Force

A Concept of Operations (ConOp) is being developed by the Canadian Air Force to implement a distributed simulation training capability. This Canadian Air Force ConOp is being developed “*to provide consistent direction, unity of effort, and alignment with existing policy*” [Grant].

The Canadian Air Force currently conducts many live collective training events. These events provide valuable mission training to the Air Force, but cost, operational tempo, asset availability, safety, and security constraints limit the amount of such training that can be accomplished. Consequently, the Air Force has decided to use distributed simulation to conduct additional mission training. Grant et al. consider the circumstances for employing distributed simulation for mission training in a small, multi-purpose air force.

Distributed simulation can contribute to collective training while offering several benefits relative to live training, such as safety, cost, security, and environmental concerns.

Canadian Air Force DMT events will supplement, not replace, the various live collective training events conducted by the Air Force.

Table 11 Synthetic Range Interoperability Model for the Norwegian JADE II Synthetic Exercise

JADE II JJTTCF
ADS: DIS IEEE 1278.1/A HLA IEEE 1516 DLC Compliant FOM is based on RPR-FOM V2D17 MaK RTI
Radio Communications : VoIP
Tactical Data Link : Link-16 JREAP (and Socket-J/SISO-J ?)

The Canadian DMT capability must enable the execution of all required types of events and a key aspect of this new capability is availability. Once established, this capability must be available to Air Force units on a routine basis. Barring the idiosyncrasies of simulations at

individual participating sites, engineering and development effort should not be required to conduct training events amongst arbitrary collections of sites utilising various terrain models within an established network enclave. At steady state, the effort should be primarily one of training planning, scenario development, loading available data, and scheduling.

According to this work the Canadian Air Force ConOp should seek to establish persistent and flexible data networks. The ConOp should identify the Canadian Forces Experimentation Network (CFXNet which is the Canadian segment of the Combined Federated Battle Lab network (CFBLNet)) as the wide area network for the Canadian Air Force distributed simulation capability. This facilitates establishing simulation events with the Canadian Air Force's training partners in other nations on the CFBLNet.

From a Canadian Synthetic Range Interoperability Model point-of-view:

- The Canadian Air ConOp should mandate DIS because:
 - It is identified as a preferred simulation interoperability standard in the latest NATO interoperability standards document (as is HLA) [NATO NMSSP]; and
 - The Canadian Air Force's key training partners (the USAF and the RAF) use DIS;
- Similarly HLA should also *be identified (?)* in a ConOp;
- HLA and DIS simulation of radio/voice traffic should be supported, as should Voice over IP (VoIP); and
- There is no mention of support for tactical data links.

Interoperability with Canadian Service and coalition simulation networks are pivotal issues to establishing an effective distributed simulation capability.

5.7 NATO Interoperability Standards

The objective of the NATO Modelling and Simulation Standards Profile (NMSSP) is to provide guidance regarding modelling and simulation (M&S) standards and processes to NATO and partner nations, as well as national and NATO organisations that have to effectively use M&S in support of NATO and national requirements.

The NMSSP standards discussed in section 2.4 are not the only interoperability standards supported by the NATO NMSSP however the other standards mentioned in the NMSSP are not relevant to this discussion. The NATO NMSSP Synthetic Range Interoperability Model (relevant to this discussion) is shown in Table 12.

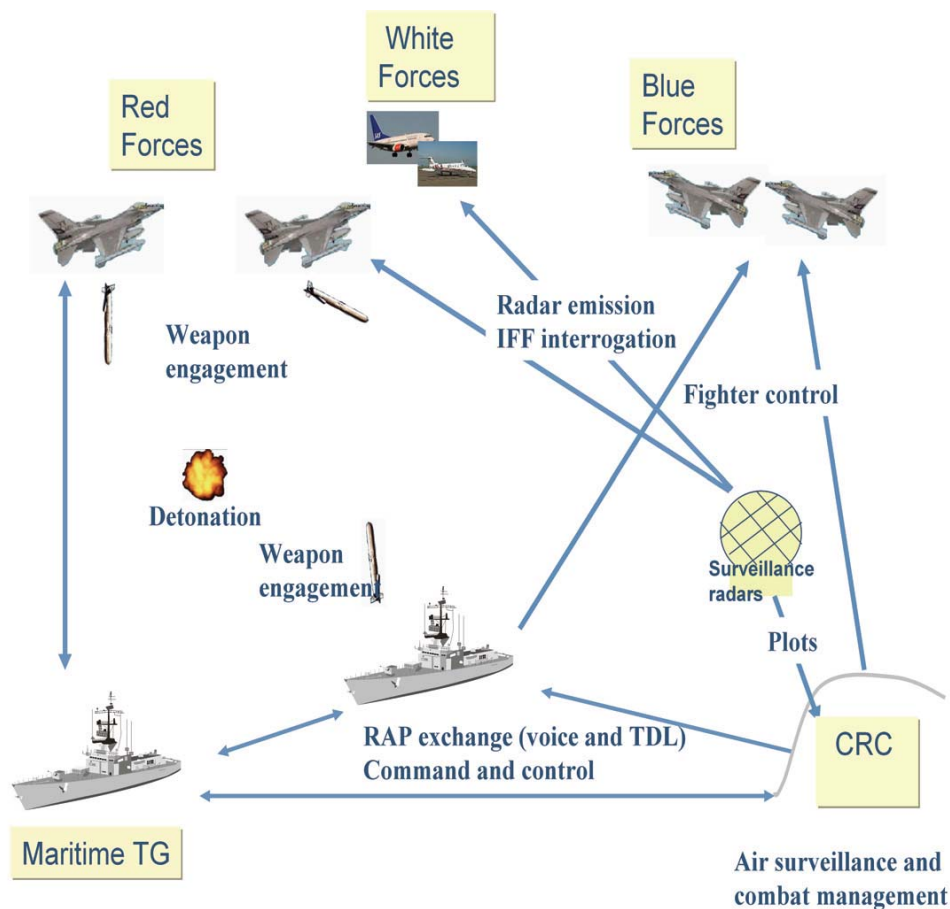

Figure 11 The JTTCP Conceptual Model

The NATO NMSSP recognises that there are benefits to identifying and using common open standards, however due to the breadth of application of M&S there is no "one size fits all".

What the NATO NMSSP is recommending is that only standards that are included in the NATO NMSSP be used for any LVC programs or projects. Therefore one would hope that any interoperability standards mentioned in all of the (tabular) project or program Synthetic Range Interoperability Models mentioned in sections 4 and 5 have also been recommended in the NATO Modelling and Simulation Standards Profile (Table 13). However the NATO NMSSP does not include the JREAP Link-16 transport protocol [MIL-STD-3011]. This means that systems that only support interoperability standards recommended in the NATO NMSSP may only be restricted to supporting JTIDS and MIDS Link-16 communications systems (i.e. no SATCOM systems). The fact that JREAP is not in the NATO NMSSP is a deficiency of the NATO Modelling and Simulation Standards Profile. JREAP is included the recommended ADF Corporate Synthetic Range Interoperability Model.

The NATO NMSSP standards of relevance when compared to the (recommended) ADF Corporate Synthetic Range Interoperability Model are shown in Tables 12 and 13.

Table 12 The NATO NMSSP Synthetic Range Interoperability Model

NATO NMSSP
ADS: DIS IEEE 1278.1/A HLA IEEE 1516 DLC Compliance FOM is based on RPR-FOM TENA
Radio Communications : No mention
Tactical Data Link : Link-11 and Link-16 SIMPLE and SISO-J

The NATO NMSSP does not recommend any Radio Communications interoperability standards as LVC Radio Communications interoperability standards would be covered by real radio system standards (which are not addressed by the NATO NMSSP) and the Virtual and Constructive LVC component Radio Communications interoperability standards are covered by the IEEE 1278.1 (i.e. DIS) Radio Communications PDU Family and their HLA (through the RPR-FOM) (and TENA) equivalents.

A comparison of the Synthetic Range Interoperability Models analysed in this report is shown in Table 13 and the recommended ADF Corporate Synthetic Range Interoperability Model) is shown in Table 14.

This recommended ADF Corporate Synthetic Range Interoperability Model only defines the minimum level of interoperability that all potential ADF LVC interoperable systems should be specified to have when acquired (i.e. tested and accepted) by the Commonwealth.

Also note that the NATO NMSSP does not recommend PDUs or PDU fields – which (eventually) the ADF Corporate Synthetic Range Interoperability Model will (must). Unless all the relevant “bits and bytes” are unambiguously and precisely defined a LVC system could be delivered with DIS or (especially) HLA [Tudor] and not be interoperable with other similarly specified LVC systems.

The NATO Modelling and Simulation Standards Profile can only provide limited guidance – it reduces risk but it will not guarantee interoperability!

The objective of developing the ADF Corporate Synthetic Range Interoperability Model is that it would be so tightly defined (i.e. specified) that any LVC system that complies with the ADF

Corporate Synthetic Range Interoperability Model will have a guaranteed level of “out-of-the-box” interoperability thus reducing risk and cost to the Commonwealth.

Table 13 Comparison of Synthetic Range Interoperability Models

Model Name	ADS	Radio Comms	Tactical Data Link
USAF (DTE5)	DIS IEEE 1278.1/A Entity State PDU Fire/Detonation PDU EE PDU IFF PDU	ASTi DACS Transmitter PDU Signal PDU Receiver PDU	Link-16 SISO-J
USN (DTE5 and Watson experiments)	DIS IEEE 1278.1/A Entity State PDU Fire/Detonation PDU EE PDU IFF PDU HLA DTE FOM MaK RTI	ASTi DACS Transmitter PDU Signal PDU Receiver PDU	Link-16 SIMPLE
US Army (DTE5)	DIS HLA DTE FOM MaK RTI MATREX FOM MATREX RTI	ASTi DACS Transmitter PDU Signal PDU Receiver PDU	None? (must now be VMF)
UK MASC	DIS HLA	DIS Voice Comms Transmitter PDU Signal PDU	Link-16 SISO-J
NATO Spanish LVC	DIS IEEE 1278.1/A HLA IEEE 1516 RPR-FOM V2D17 MaK RTI	Verbal	Link-16 SISO-J (DIS and HLA)
JADE II JJTTC	DIS IEEE 1278.1/A HLA IEEE 1516 RPR-FOM V2D17 MaK RTI DLC Compliant	VoIP	Link-16 JREAP Socket-J / SISO-J ?
NATO NMSSP	DIS IEEE 1278.1/A HLA IEEE 1516 RPR-FOM V1 and V2 TENA	No mention	Link-11 and Link-16 SIMPLE and SISO-J
Recommended ADF Corporate Synthetic Range Interoperability Model	DIS IEEE 1278.1/A Entity State PDU Fire/Detonation PDU EE PDU IFF PDU HLA DoD V1.3 or IEEE 1516 equivalent RPR-FOM V2D17 DLC Compliance	DIS IEEE 1278.1/A Transmitter PDU Signal PDU Receiver PDU or HLA RPR-FOM equivalent	Link-16 JREAP SIMPLE SISO-J

The NATO Modelling and Simulation Standards Profile (NMSSP) will not achieve this objective!

5.8 Comparison of Synthetic Range Interoperability Models

A comparison of the Synthetic Range Interoperability Models analysed in this report is shown in Table 13. It is clear from Table 13 that any system that complies with the recommended ADF Corporate Synthetic Range Interoperability Model should be highly interoperable (may still need COTS or GOTS Gateways) with the other systems shown in Table 13 as long as other exercise parameter classes (Enumerations, Site IDs, etc) are also compliant.

Table 14 The Recommended ADF Corporate Synthetic Range Interoperability Model.

ADF Corporate
ADS: DIS IEEE 1278.1/A Entity State PDU Fire PDU Detonation PDU Electromagnetic Emission PDU IFF PDU or equivalent HLA DoD V1.3 or IEEE 1516 DLC Compliance FOM is based on RPR-FOM V2D17
Radio Communications : IEEE 1278.1 Radio Communications Family PDUs Transmitter PDU Signal PDU or the HLA RPR-FOM equivalents
Tactical Data Link : Link-16 JREAP, SIMPLE and SISO-J

5.9 Section Summary

Section 5 has analysed various coalition LVC systems in order to compare their LVC Synthetic Range Interoperability Models and the interoperability standards used.

The objective of the NATO Modelling and Simulation Standards Profile (NMSSP) is to provide guidance regarding modeling and simulation standards and processes to NATO and partner nations recognising that “one size does not fit all”. The NATO NMSSP should contain all the LVC interoperability standards that should be considered when developing a Synthetic Range Interoperability Model - it does not recommend exactly which ones should be used.

Even with the interoperability standards recommended, the NATO NMSSP does not recommend or define a minimum level of interoperability that all LVC systems should have. It does not define interoperability standard components precisely and unambiguously (eg DIS PDUs and DIS PDU fields) at the level required so that each LVC system should be highly interoperable “out-of-the-box”. This NATO NMSSP approach does not guarantee interoperability - it simply reduces risk!

The recommended ADF Corporate Synthetic Range Interoperability Model will eventually define interoperability standard components precisely and unambiguously so that each LVC system should be highly interoperable “out-of-the-box” - it aims to guarantee a minimum (but useful) level of Corporate LVC interoperability.

Of the coalition systems analysed the UK LVC systems appear to be highly interoperable with the USAF DMO systems as they appear to use very similar (if not identical) interoperability standards - this is also the intention of the recommended ADF Corporate Synthetic Range Interoperability Model. This may not be the case with the NATO systems (and possibly the Canadian systems although they participated in USA, UK and Canadian coalition MTDS exercises and should therefore be USAF DMO compliant) as the data available and the philosophy used in the NATO Modelling and Simulation Standards Profile do not appear to specify the interoperability components precisely and unambiguously in order to guarantee interoperability.

The comparison of Synthetic Range Interoperability Models shown in Table 13 indicates that any system that complies with the recommended ADF Corporate Synthetic Range Interoperability Model shown in Tables 13 and 14 should be highly interoperable (or should be able to be made highly interoperable using cost-effective COTS or GOTS Gateways) with the other LVC systems shown in Table 13. Therefore any system that complies with the recommended ADF Corporate Synthetic Range Interoperability Model should be highly interoperable “out-of-the-box” at system delivery and acceptance thus reducing cost and risk to the ADF.

6. The USAF LVC Distributed Mission Operations (DMO) System

6.1 The US Air Force DMO System

Simulation technology today allows warfighters to participate in a continuous training cycle and maintain a high state of combat readiness by using cost-effective simulation alternatives in conjunction with live-fly operations and training missions. Current development of live, virtual, and constructive (LVC) systems for training and mission rehearsal, the rapid advancement of networking technologies and protocol standards/architectures such as Distributed Interactive Simulation (DIS) and High Level Architecture (HLA) have all contributed to an environment where highly-distributed training, mission rehearsal, operations support, and multi-force DMO joint/coalition exercises have become a reality [Portrey].

DMO has become a critical component in (US) Warfighter preparation enabling the Warfighter to obtain and maintain combat readiness mission rehearsal in operationally realistic environments. The DMO environment prepares the Warfighter by providing the ability to learn, and repeatedly practice skills and techniques that can be validated and sharpened through live training and real world use such as targeting, sorting, and proper team communications. DMO also allows multiple players at the same or multiple sites to participate in training scenarios ranging from individual and team sorties to full theatre-level battles [Portrey].

The USAF Distributed Mission Operations (DMO) is the cornerstone for Air Force training transformation supporting the US DoD Strategic Plan for Training Transformation and supports Service level and Joint National Training Capability (JNTC) objectives. The objective is to “*train the way we intend to fight*”, enabling Air Force warfighters to maintain combat readiness and conduct mission rehearsal in an environment as operationally realistic as possible [Ales].

DMO is also the USAF’s attempt to provide complete integration of live, virtual, and constructive systems for training, mission rehearsal, and operations support in a theatre of war environment. It will enhance the kill chain by enabling the sensor to shooter training links that are currently not available because of the high demand realities of our limited ground and airborne C2 systems. The realism achieved by this capability will further increase the commander’s ability to “be inside the opponent’s decision loop” and improve combat effectiveness. The Army has a similar effort to achieve JNTC objectives through their Live, Virtual, Constructive – Integrating Architecture and Infrastructure (LVC-IA) Program [Ales].

The USAF Combat Air Forces are migrating their readiness training to a new capability that uses theory-driven and operationally-defined specifications for the knowledge, skills, and experiences that are needed for mission readiness performance in complex combat environments. These specifications are known as Mission Essential Competencies (MECs). MECs are “higher-order individual, team, and inter-team competencies that a fully prepared pilot, crew, or flight requires for successful mission completion under adverse conditions and in a non-permissive environment”. More proficiency in all of the MEC skills has been shown

to correlate directly to the success in end of training performance and in subsequent unit and exercise performance. Success in these contexts is also indicative of the likelihood of success during a combat mission. Competency-based training in a DMO environment has proven to contribute to increased expertise in MEC skills and other critical air combat knowledge [Portrey].

DMO has matured significantly in recent years and offers a venue to increase warfighter readiness by complementing live-fly training. DMO and LVC integration have the capability to enhance combat training by exposing warfighters to high-fidelity training in an immersive environment and to incorporate operational-level processes that can impact mission accomplishment [de Anda].

Individual flight simulators have been available for many years, but technological improvements have allowed the creation of synthetic battlespaces for distributed, integrated warfighter training.

The U.S. Air Force DMO Program provides realistic training to warfighters. For this distributed training to be as realistic and effective as possible, it incorporates not only US Air Force assets and personnel but Army, Navy, Marine and coalition force resources as well. To accomplish this feat a synthetic environment is created in the form of a virtual “battlespace” which is then distributed to warfighters throughout the U.S. and overseas using real-world equipment, virtual simulations, and Computer Generated Forces (CGF) (i.e. LVC systems).

The applications span the full spectrum of warfighter training including team, inter-team, large force, and theatre-level employment but it can also concentrate on smaller, focused scenarios. The DMO synthetic battlespace can enable some training not available other than while at war.

Some DMO synthetic battlespace LVC training is of such size and complexity that it would be next to impossible to recreate in a live exercise because of resource constraints, cost, and scheduling conflicts with real world operations.

Even though these training events are USAF-centric they also include participants from other US services and coalition partners. The USAF benefits from having this broad environment; it allows for Joint services and coalition training events; and other US services and coalition partners can build on the lessons learned from integrating with the USAF [Grevin].

According to Hambleton and Lollar [Hambleton] the objectives identified in the USAF DMO Concept of Operations (CONOPS) include:

- Train warfighters as they expect to fight;
- Maintain combat readiness at home or deployed;
- Conduct mission rehearsal in an environment as operationally realistic as necessary; and

- Provide support to operations using real-world operational systems, advanced mission simulators, and constructive simulations to form a networked and distributed synthetic battlefield.

6.2 Why Do We Need Such Systems?

Traditional air combat tactical pilot training consists of ground-based training, simulation-based, and live flight training to teach avionics usage and cognitive flying skills. While ground based training can be a very economical method of pilot training, it is not robust enough to cover critical dynamic skills. Live flight training can provide this enhanced training capability, but can be very costly in nature. For example, in order to perform a training sortie indicative of an operational sortie, a compliment of aircraft must be fielded to represent both blue forces and red forces. Mission roles and routes must be planned and coordinated. Fuel must be allocated, flight schedules deconflicted, and maintenance completed to allow asset readiness. Availability of resources, allocation and scheduling of integrated air defence assets on Air Combat Maneuvering Instrumentation (ACMI) ranges limits training options. Inclusion of command and control nodes such as Airborne Warning and Control System (AWACS) adds another dimension to the complexities of coordinating a true-to-operation training sortie. The costs of pulling together these assets can be in the hundreds of thousands of dollars per event and are both cost prohibitive and time consuming. The training or readiness value added for highly skilled pilots to fly in a red air role can be questioned. Additionally, use of the real assets adds to platform wear, requiring additional maintenance and accelerating ageing of the air fleet.

In recent years, training capabilities have moved beyond cognitive skills training to tactical operations training through ground-based training devices. This is evidenced by the growth of squadron-based pilot training systems that interoperate in a distributed training environment, such as the US Air Force's Distributed Mission Operations (DMO) environment and the US Navy's Naval Aviation Simulation Master Plan (NASMP) environment. These environments dictate that systems must fully represent the weapons platforms in an operational environment to include authenticated avionics and sensor models, air threats, integrated air defence systems, and command and control nodes. These systems must interconnect (i.e. interoperate) from base to base through government operated networks via standards-based protocols [Lechner].

Senior US Air Force leaders consistently emphasise two themes in advocating the USAF DMO program [Chapman]:

1. A significant portion of combat training for new weapons and combat systems such as the F-22 can only be accomplished in high-fidelity simulators. For land-based fighter and bomber aviators the most demanding tasks of a combat mission occur between landing and takeoff: formation flying, air refueling, engaging an enemy air defence system, delivering weapons close to ground forces, etc; and
2. The battlespace is a dynamic interaction environment among other military actions and the adversary. Military pilots need to train as part of the entire kill chain.

Prior to the fielding of DMO capable systems, simulators did not contribute significantly to operational fighter squadron's mission training. Figure 12 [Chapman] depicts simulator requirements for a typical fighter pilot as he or she progressed through formal training and into an operational fighter.

In initial training about half of the training sorties are accomplished in a simulator. Once the pilot reaches an operational fighter squadron however, the yearly requirement for inexperienced pilots is 12 simulator sorties per year. The requirement falls to 8 per year for experienced pilots. In both cases the simulator sorties are oriented to single-ship procedural tasks.

DMO training missions are designed to maximise exposure to the most crucial mission skills. Only about 15 minutes of a wartime mission is complex and intensive. That critical 15 minute period, releasing weapons close to friendly forces, attacking a time critical target, engaging an unknown air contact, while usually only done once on an operational mission is practiced several times during a training sortie.

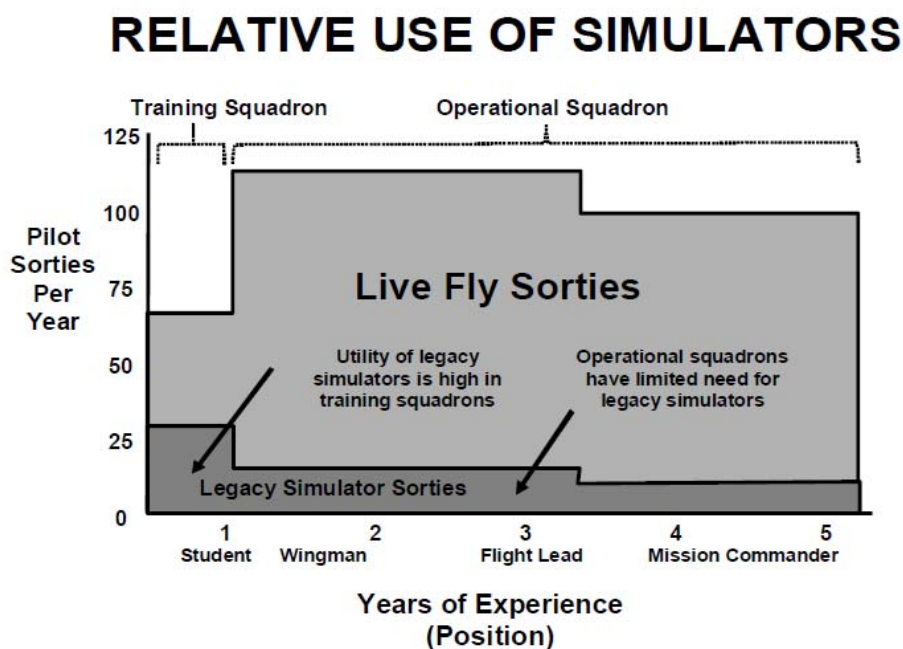

Figure 12 Typical Simulator Requirements From Formal Training to an Operational Pilot

Training sorties are fairly short, usually 75 to 90 minutes. Depending on a number of factors, it takes 2 to 3 years of operational flying to produce an experienced pilot, 3 to 4 years if formal training is counted.

Real combat sorties are 3 to 6 times longer than training missions. Most of the added flight time is spent getting to and from the target area, an important but mundane activity.

Nevertheless, these flying hours count towards the 500 hour metric often used to define an “experienced” pilot.

Furthermore, in some mission skills, deployed pilots lose proficiency. Operational units must be proficient in several types of missions, as determined by the needs of each theatre. Skills needed for Iraq are different than those needed to support Pacific requirements. However, units deployed to support the war in Southwest Asia only perform missions in support of operations there. They do not fly training missions and may therefore incur deficiencies in critical mission skills needed for other theatres.

Because of these factors, pilots are receiving less relevant (i.e. mission) experience per flying hour. Leaders of operational units report that pilots reaching the 500 hour standard are often not exhibiting the level of knowledge and skill needed for leadership positions as flight leaders, instructor pilots, and mission commanders [Chapman].

Deployed pilot proficiency and readiness in mission critical skills is decreasing due to Operational Tempo. Data from Operation Iraqi Freedom and Operation Enduring Freedom has shown that pilots spend airborne time performing combat air patrols and circling areas of responsibility. This does not allow for much training in mission critical skills such as basic fighter manoeuvres, combat tactics, and weapons employment - all of which are deteriorating due to lack of available time to perform skill training in theatre. The US DoD has chosen the mantra “*Train like we Fight*”; however given the expense and danger of launching live weapons and the complexities of missions representing battlefield conditions, pilots infrequently get an opportunity to train as they would fight.

An approach to solving the above limitations and deficiencies is the incorporation/integration of live platform training into the (vastly) successful implementation of distributed mission training (eg DMO). LVC has the ability to bring forward a complex battlefield with a dense, realistic, current threat environment, providing the ability for aircraft to collaborate, sort, target and launch on reactive targets. Reuse of existing recording and after-action review capability can provide high-fidelity, correlated, synchronized scoring and feedback for training operations. Lastly, depending on the implementation, this capability can be used both pre-deployment and deployed in theatre [Lechner].

According to Hambleton and Lollar [Hambleton] the LVC future suggests the integration of range-based training will become a bi-directional exchange of data perhaps requiring some modifications to weapon system radars and sensors to allow their stimulation by virtual and constructive entities, threat signals, jamming and other battlefield environmental elements. Although placing virtual and constructive entities “on the range” to interact with live systems may limit training value for missions requiring visual contact, electronic warfare and ISR assets may find that robust computer-generated range environments offer a more realistic training experience against a broader set of current and emerging threat systems than is currently available using range-based threat systems.

Colgrove et al. [Colegrove] have reported on work to determine the “optimal training mix” of live to simulator training events per month that are required for an experienced and inexperienced pilot to be proficient and highly proficient where:

- **Proficient** is where squadron members have a thorough knowledge of mission area and occasionally may make an error of omission or commission. Aircrew are able to operate in a complex, fluid environment and are able to handle most contingencies and unusual circumstances. Proficient aircrew are prepared for mission taskings on the first sortie. in theatre; and
- **Highly proficient** is where squadron members have a thorough knowledge of mission area and rarely make an error of omission or commission. Aircrew are able to operate in a complex, fluid environment and are able to handle most contingencies and unusual circumstances. Highly proficient aircrew are prepared for the mission taskings on the first sortie. in theatre.

This Colegrove et al. “optimal training mix” data is shown in Table 15.

Colegrove et al. also present the data shown in Table 16 that compares the current training mix with the predicted optimal training mix for Inexperienced Pilots to remain Proficient.

Colegrove et al. did not indicate what air platform this data was referring to.

As a result of this work, fighter and bomber training managers are implementing new, and usually increased, simulation training requirements. At the end of the current revision cycle simulation training will comprise between 20 and 30% of the required training within the USAF Combat Air Forces [Colegrove].

Table 15 Predicted Optimal Training Mix of Live and Simulation System Training Events per Month.

	Proficient		Highly Proficient	
	Live	Simulation	Live	Simulation
Inexperienced	15	7	21	8
Experienced	12	5	17	7

In March 2006, the US Air Force decided that approximately 20% of its F-15C live-fly training requirement would be done in DMO-capable simulator systems and that these DMO sorties would be counted towards the 500 hour “experience” metric [Chapman].

Table 16 Comparison of Current Training Mix of Live and Optimal Training Mix per Month for Inexperienced Pilots to Remain Proficient

	Current	Optimal Training Mix
Live Sorties per Month	11	15
Simulation Missions per Month	4	7

6.3 DMO Components

It is clear from doing the literature survey for this report that coalition Air Forces are moving towards adopting the interoperability standards (i.e. including the Synthetic Range Interoperability Model) of the USAF Air Force (eg USAF DMO LVC interoperability standards), coalition Navies are moving towards adopting the interoperability standards of the US Navy, etc.

No (equivalent) corporate ADF or RAAF LVC interoperability standards exist. It is therefore most likely that when the RAAF eventually move towards creating or adopting corporate interoperability standards that they should attempt to adopt those standards already developed and used by the USAF.

This current section (i.e. section 6) will therefore aim to provide a highly detailed description (reproduced from some excellent papers including [Aldinger]) describing the USAF Distributed Mission Operations (DMO) program – sometimes referred to as the Combat Air Force (CAF) DMO or the Distributed Mission Training (DMT) system. The DMO program is the foundation for revolutionising training in the USAF - it provides a training architecture that supports both inter-team and intra-team composite force training for warfighters located in geographically separate locations. The training focus is on the operational and strategic training of the warfighter [Aldinger].

The USAF DMO system is being continuously evolved to support a routine DMO LVC training capability that bridges the commonly used DIS, HLA and TENA interoperability protocols. As discussed in section 5 (interoperability with) the USAF DMO system is being implemented by the RAF and the Canadian Air Force.

DMO Mission Training Centers (MTCs) provide a capability for high-fidelity, man-in-the-loop (pilots, weapon system officers, C2ISR crew stations, etc) and platform (F-15, F-16, AWACS, etc) simulators to participate in distributed training events. MTCs also provide other ancillary components such as manned threat stations, instructor-operator stations, Computer Generated Forces packages, Brief/ De-brief stations, Loggers etc.

MTCs are connected via the DMO Network (DMON) which is a persistent, classified Wide-Area-Network that provides global connectivity between MTCs and control of the whole DMO system. During 2008 more than 380 DMO training events involving many DMO sites (45 DMOC plus 40 External sites according to [de Anda]) were carried out over the DMON.

Some key points of the DMO system are:

- Training is available 24/7;
- All training systems must comply with a rigid set of DMO interoperability standards;
- MTCs provide high-fidelity, man-in-the-loop platform simulators including friendly and adverse forces;
- Multiple/simultaneous training events are supported; and
- Lead time is 1 hour for archived scenarios.

The primary elements of the CAF DMO architecture include the DMO Network, Interoperability Standards, the DMO Portal, and Mission Training Centers. These components are described in some detail below.

6.4 DMO LVC (Simulation) Assets

Synthetic battlespace simulation assets are classified into three groups: Live, Virtual, and Constructive. Live assets are the air platforms themselves, and they offer the highest level of realistic training to the warfighters from the “touch-and-feel” point of view. However, these systems can provide better, more realistic training if they are stimulated with realistic scenarios that adequately meet all warfighter training requirements. The scenarios need to be rigorous, yet flexible enough to adjust the environment to push the training audience beyond what they might encounter in other training venues, and yet, meet all of their training objectives. Unlike other simulation devices, live assets must be stimulated with real-world protocols and interfaces just as they would in real combat. The DMO synthetic battlespace network is designed to support most, if not all real-world tactical data link protocols including Link-16, NATO-EX, Hook 112, Intelligence Broadcast Service - Interactive (IBS-I), IBS-Simplex (IBS-S), and Surveillance Control Data Link (SCDL). Because of these factors, Command and Control (C2) assets in these synthetic battlespace training events can provide a highly realistic tactical data link “picture” to virtual and/or live assets.

Virtual assets are usually defined and known as flight simulators, which are the most common types of virtual simulators throughout the USAF. These include air to air shooter platforms, such as the F-15C, and F-16, Air to Ground, or F-15E and A-10, and the USAF bombers B-52, B-1B, and B-2. Also included are Command and Control Virtual simulators, such as the E-3 AWACS, E-8 JSTARS (Joint Surveillance and Target Attack Radar System), and the CRC (Ground-based Control and Reporting Center). Other USAF and US Army Special Operations Forces aircraft include the Unmanned Aerial Vehicles (UAV) simulations known as Hunter, Predator, MQ-1 and MQ-9, and the C-17 and C-130 aircraft. Warfighters have been training on these virtual simulators for years. The typical training has been cockpit familiarisation, basic procedures, flight tactics, weapons employment, emergency procedures, and flying in adverse weather conditions if the virtual simulator has an appropriate level of fidelity. DMO virtual simulators have been used for mission rehearsal and mission crews can train for future missions in their simulators using realistic terrain and threat representation. F-22 and JSF systems may now also be included.

Constructive assets are defined as forces or platforms created by a computer simulation, also known as Computer Generated Forces (CGF). Computers can also simulate battlefields consisting of friendly, opposing and neutral entities: aircraft, ground offensive and defensive forces, and fixed targets as well as realistic airborne and ground threats and countermeasures. Enemy forces are usually created using constructive simulations, but to provide a higher fidelity training environment, virtual platforms can be reconfigured as either friendly or enemy forces. Additionally, friendly constructive entities are also created because there are simply not enough virtual simulations and live assets available to create an entire theatre-level synthetic battlespace.

DMO uses many CGFs to create a synthetic battlespace. Some have very specific capabilities, with a narrow focus, while others support a wide range of applications. However a single CGF may not satisfy all requirements of a synthetic battlespace training event. There are about a dozen different CGFs used in DMO alone (in 2007). Each has its strengths and weaknesses, and an appropriate mix may be required to efficiently achieve an adequate level of fidelity and realism. For example, the DMOC uses the Scenario Toolkit and Generation Environment (STAGE) CGF to supplement the friendly airborne forces commonly referred to as "blue air." The blue air scenario follows a published Air Tasking Order (ATO), which can be pre-scripted depending on specific training requirements. The DMOC also uses the Next Generation Threat System (NGTS) CGF to create enemy forces. NGTS creates a high fidelity airborne threat environment, known as "red air."

To enhance the ground portion of the synthetic battlespace the Distributed Information Warfare Constructive Environment (DICE) CGF may provide the high fidelity integrated air defence systems (IADS) modeling necessary to realistically conduct the suppression of enemy air defences (SEAD) missions. Its high fidelity modeling of IADS creates a high fidelity air defence representation for the virtual shooter and sensor platforms. Two other "ground" CGFs are used as well, the Extended Air Defence Simulation (EADSIM) CGF, which offers a very specialised tactical ballistic missile (TBM) simulation, and the Joint Constructive And Tactical Simulation (JCATS), which can provide up to 50,000 separate friendly or enemy ground entities [Grevin].

6.5 DMON - The DMO Network

The DMON is a persistent network that provides an on-demand daily training capability for USAF DMO systems. It is a high bandwidth, low latency, robust, scalable, secure, highly reliable network service that makes use of high availability commercial data services in order to achieve the network availability required by CAF DMO user systems.

A DMON Network Operations Center is responsible for monitoring, maintaining and administrating the network for training exercises and providing a DMO Help Desk. At the end of 2008 29 sites were operational on the DMO Network.

6.6 DMO Interoperability Standards

The application of interoperability standards is used to facilitate a high-reliability, routine, daily training capability. These interoperability standards apply to all MTCs and DMO LVC systems participating in CAF DMO events being executed on the DMON.

Initially, MTCs had been developed to support their own specific intra-team training needs without any common standards guidance. This resulted in highly efficient training systems which were focused on achieving the specific intra-team training objectives for their own platform. However from a DMO “System of Systems” perspective, this resulted in an outcome that was not readily capable of supporting distributed inter-team training.

At this time, the DMO systems lacked the interoperability solutions required for inter-team training due to:

- Differing approaches executed in implementing platform functionality; and
- The lack of additional MTC functionality required to support inter-team training requirements.

To rectify this issue and maintain a controlled test environment where effective test and evaluation could be conducted required that MTCs “under test” needed to be “Certified” as compliant to the effective standards (i.e. accredited) prior to test activities. Experience has shown that time lost during standards certification activities was easily recouped through a test environment where the majority of the unknowns were resolved, through certification, prior to test. This controlled test environment greatly simplified the identification and resolution of test anomalies.

Standardisation of simulation protocols such as HLA and DIS and conventions such as units of measure, coordinate systems, and battlespace representation go a long way towards simplifying the integration of disparate systems but by no means resolve all potential issues. An ‘agreements’ document has been developed which specifies system settings (e.g. communication parameters, exercise ID numbers, IP addresses) to ensure that interoperability tests proceed smoothly. Failure to identify and establish such ‘agreements’ prior to test execution will eventually lead to frustration and an uncontrolled test environment.

The USAF DMO requires the implementation of DMO system standards by all DMO participants (eg MTCs) to achieve a plug-n-play type solution. A process is also available to provide stakeholders with a mechanism to contribute to the focus and content in the evolution of these DMO interoperability standards.

According to Aldinger and Keen [Aldinger] the twelve DMO standards are categorised as follows:

- Interface Standards - address network connectivity, software and hardware interfaces, and protocols necessary for MTCs to exchange information;

- Integration Process Standards – documents common processes and procedures that facilitate coordinated operation of DMO systems as part of the harmonized CAF DMO system. Grevin and Sorroche [Grevin] give some insight into the processes required to carry out a typical DMO training exercise; and
- Federate System Performance Standards - address consistency, fidelity and performance factors, ensuring a fair fight among training participants.

These twelve DMO interoperability standards have been determined as necessary to achieve DMO training objectives with the integrated capabilities of the available Federate Systems in a DIS and HLA compliant network. These DMO standards are now described briefly below.

6.6.1 The Network Standard

The DMON is a complex system consisting of the Northrop Grumman Portal (section 6.8), network equipment, encryption devices, and a commercial Wide Area Network (WAN). The Network Standard specifies criteria that define the protocols, physical connections, and facility requirements needed to interface with the DMON. DMO system providers must adhere to the criteria outlined in this standard to ensure reliable and repeatable network connections. In addition, the Network Standard defines criteria for network applications that do not readily fit within other CAF DMO Standards.

6.6.2 DMT/CAF DMO Distributed Interactive Simulation (DIS) Standard

The DMO Tailored DIS Standard is based on the IEEE DIS 1278.1/A standard. It describes the specific implementation of DIS in the DMO environment. The standard is the reference for CAF DMO protocols that are subject to interpretation in or anticipate changes to the IEEE 1278.1/A standard. These Simulation Interoperability Standards Organization's (SISO) based standards have been tailored to address the high-fidelity training requirements necessary to meeting DMO inter-team training objectives. See [Zalcman (2004) - 1] and [Zalcman (2004) - 2] for similar work done for the ADF.

6.6.3 High level Architecture (HLA) Reference Federation Object Model (RFOM) Standard

According to Aldinger and Keen [Aldinger] the DMO RFOM Standard provides guidance for implementing the DMO RFOM for HLA-based simulations. It is based on the SISO-STD-001 Real-time Platform-Based, Reference FOM (RPR-FOM). It also incorporates the Link-16 BOM described in SISO-STD-002 [SISO] and ASTi Simulation Object Model (SOM) for radio communications. These HLA components should all be combined into the latest (draft) version of the RPR-FOM Version 2 documentation [RPR-FOM].

6.6.4 Security Standard

The DMO Security Standard includes all aspects of system security and requires compliance with existing US National, Department of Defense, Air Force and commercial security doctrine, directives, instructions, and practices.

The Security Standard addresses the development of security test and evaluation procedures applicable to all DMO systems. Compliance with this standard is demonstrated and documented through the certification and accreditation processes described by both the National Industrial Security Program Operating Manual (NISPOM) and by the US Air Force Systems Security Instruction “*The Certification and Accreditation Process Handbook*” (AFSSI 5024).

6.6.5 Event Control Standard

The DMO Event Control Standard addresses required automated and procedural activities that each participating MTC must perform to organise, manage, and control a distributed training event. This standard addresses DMON test and training event planning, scheduling, scenario generation, initialisation, execution, monitoring, and close out. The roles and responsibilities for coordination and production of mission data needed to support all of these activities are defined in the standard.

6.6.6 Data Sharing Standard

The DMO Data Sharing Standard addresses all data sharing and collection considerations that require cooperative and/or interoperable support among DMON sites not provided within the context of other CAF DMO standards. For example, information conveyed by simulation protocol in direct support of simulation execution is governed by the Tailored DIS and RFOM standards, but standardisation of log file content and format for the purpose of supporting common analysis tools or shared playback control techniques would fall under the DMO Data Sharing standard. This standard includes criteria governing the sharing and collection of data to support mission planning, briefings, run-time analysis, post event analysis and debriefing, and generation of after-action review products. The standard identifies the data to be shared, how it will be collected, how it will be made available, where/how the data will be transferred, in what formats it will be transferred and/or stored, what access controls will be applied, how the data will be organised, what access methods will be available, and how it will be viewed/displayed.

6.6.7 Common Models Standard

To function together in a common synthetic battle environment, DMO systems share data specified in the Tailored DIS and RFOM Standards across the DMON according to the DMO Network Standard. DMO system simulations must act upon this shared data, as well as local data, in a way that provides the best possible training value to DMO participants. Of specific concern is that models of related or common phenomena, events, and actions perform with

sufficient similarity across the various DMO systems so that collective training goals are achieved. Where necessary to ensure interoperability and consistency of representation for phenomena, events and action across the DMO battle space, the Common Models standard will specify algorithms, models, and/or related parameters and constraints for Federate Systems to use in common within their simulations. See [Zalcman (2003)] for similar work done for the ADF.

6.6.8 Conformance Testing Standard

The Conformance Testing Standard defines the processes, documentation and personnel required to accomplish each level of the standards conformance testing process and assigns responsibilities to the various DMO contractors and sponsors responsible for DMO system testing. This standard defines the processes to be followed to ensure that DMO systems comply with the various DMO System Standard criteria and are able to interoperate over the DMON.

6.6.9 Threat Representation and Computer Generated Forces Standard

Environment Generators are essential to filling out the virtual battlespace and creating a realistic training environment. The threat models must be consistent in fidelity and behaviour, or the quality of the training could be adversely affected. In addition, management of the distributed CAF DMO network demands that the CGF systems include adequate control functionality and common interoperable protocols for invoking them. The Threat Representation and Computer Generated Forces (TRCGF) Standard addresses these issues, and imposes conformance criteria on CGF systems to insure they meet these expectations.

The TRCGF Standard addresses such issues as transfer ownership, the ability to interact appropriately with external battlespace entities, and battlespace consistency with respect to aircraft performance, radar performance, missile performance, and missile engagements. Future considerations include additions or refinements in the areas of consistency (e.g., weather), and enhanced simulation management functions or capabilities (e.g., more detailed transfer ownership requirements, entity update message metering). See [Clark (2004)] for similar work done for the ADF.

6.6.10 Technical Performance Standard

The Technical Performance Standard ensures that DMO systems meet critical technical performance requirements that are necessary for the DMO system to operate properly. The Technical Performance Standard establishes criteria ensuring consistency and interoperability of systems supporting DMO events. All system components that interact with the DMO distributed simulation battlespace are included in the scope of the Technical Performance standard, including pilot stations (i.e., ownships), threat stations, instructor operator stations (IOS), console stations and computer generated forces systems (i.e., environment generators).

The Technical Performance Standard addresses such issues as emissions representation, tracked munitions representation, and simulation protocol parameters. Future considerations include simulation modeling parameters, simulation device survivability and graceful degradation with respect to battlespace scalability, and robustness with respect to non-standard simulation messages.

6.6.11 Synthetic Natural Environment Standard

The Synthetic Natural Environment (SNE) standard specifies criteria that if met by DMO participating systems will ensure SNE database consistency and correlation required to ensure system interoperability.

The SNE database of a DMO system characterises the terrain surface, objects on the terrain, such as buildings, lighting and other cultural features that lack active behaviour, and also weather and atmosphere. Terrain characteristics of concern for interoperability include shape, land cover appearance, land condition (e.g., dusty, wet), and reflectivity properties throughout the spectrum. Object characteristics include type (identity), existence, location, orientation, and appearance. Atmospheric and weather parameters include representation of wind, rain, lightening, haze, etc. Other characteristics may be addressed in the standard as necessary to achieve interoperability.

6.6.12 Visualisation Standard

The Visualisation Standard specifies standards criteria regarding the performance and capabilities of the visual systems associated with virtual simulators as they interpret the Synthetic Natural Environment database (content) to present scene content. These criteria are formulated to minimize differences in scene content and appearance that would materially affect trainees' perception of the environment from one simulator to the next.

The visual system applies algorithms to turn SNE data into visual effects. Important factors in a scene such as lighting and darkness, shadows, haze, clouds and dust are largely controlled by the technical capabilities of visual system components rather than data in the SNE database. The Visualisation Standard is directed at ensuring that variations in these common effects as produced by different visual systems do not introduce negative training side-effects.

6.7 DMO Integration and Test Methodology

Initially operational sites were used as part of the test environment to certify new system compliance with DMO standards. However this quickly became untenable because it required resource and configuration management of operational site (i.e. testing) systems and it also reduced operational site training hours and an alternative testing network known as the Distributed Test Network (DTN) was developed.

The DTN is an expansion of the DMON to encompass contractor development sites. These development nodes must themselves undergo certification to the CAF DMO standards prior to inclusion on the DTN.

Once such compliance is achieved simple vignettes are conducted to validate observations (e.g. entities, terrain) and interactions (e.g. communications, datalinks, detonations) between sites. Then more comprehensive test scenarios are introduced to exercise a more robust battlespace. Each test activity has a pre-test and post-test telecon associated with it. In the pre-test coordination meetings, topics including go/no-go criteria, personnel issues, and security are discussed. The post-test meetings are used for achieving agreement on successes, areas for retest, System Problem Report documentation, and scheduling follow-up activities. Information dissemination and collaboration among test participants is essential for a successful test program. This can be achieved through the implementation of web pages and message boards where participants can go for up to date test documentation or to begin a thread to initiate discussion of new topics.

According to Aldinger and Keen [Aldinger] the DTN testing methodology provides an optimal means for analysing and identifying interoperability issues (such as emission parametric values, Link-16, and terrain and target correlation) which can be subtle and difficult to isolate. Only after thorough data logging and analysis can some issues be clearly understood and addressed.

In early test efforts, the lack of a coordinated system-wide Configuration Management plan did at times result in an uncontrolled test environment. This resulted in different behaviours or representations being displayed among the test sites which degraded confidence in the system and slowed integration progress. To mitigate these types of issues, a Configuration Control Board was stood up to coordinate and manage effective testing amongst multiple sites and the various DMO system updates among program elements.

6.8 DMO Portals

A critical component of the USAF DMO architecture is the DMO Portal which supports the DMO training system by isolating one MTC implementation from another. It also facilitates communication among MTCs which implement different simulation protocols (e.g. HLA, DIS) across the DMON - see Figure 13. Additional benefits provided by the Portal include the traffic management between MTCs, filtering invalid or unnecessary data produced by a MTC, routing traffic to MTCs based on simulation data values or needs, and a common user interface for MTCs to manage or view the status of a DMO event. As the Portal evolves, its capabilities and functionality continue to increase as the DMO standards expand to meet the training requirements of the DMO training system. Recently added functionality to the Portal included a state database, Dead Reckoning (DR), support for NATO EX (NEX) simulation protocol, support for multiple Local Area Network (LAN) endpoints supporting similar or disparate protocols (DIS, HLA, NATO EX, TENA), and Data Streams over the Wide Area Network.

According to Aldinger and Keen [Aldinger], in addition to supporting DIS, HLA and TENA implementations, the DMO Portal system was (2007) providing an initial DMO LVC training capability by supporting:

- DMON Interface Definition and TENA TSPi (Time-Space-Position information) – most likely required for DIS and HLA system interoperability;
- Voice / Audio data;
- LVC Link-16 Data Link; and a
- Beyond Visual Range Weapon Simulations Interface.

Figure 14 illustrates the high-level components of the Portal architecture. MTC data is received at the LAN endpoints which provide a high-performance network interface which may be configured to filter inbound local MTC simulation traffic. The WAN Controller provides filter based routing of outbound simulation traffic (if needed) and receiving Portal Speak (e.g. Portal - Portal Protocol) from remote Portals. An MTC LAN endpoint receives all network traffic and is isolated to only listen to the desired network's traffic. Any traffic that does not meet the Portal's configuration for that specific endpoint is rejected prior to being received by the LAN Controller. Valid traffic is translated into Portal Speak, a protocol transmitted between Portals and representing the DMO protocol standards.

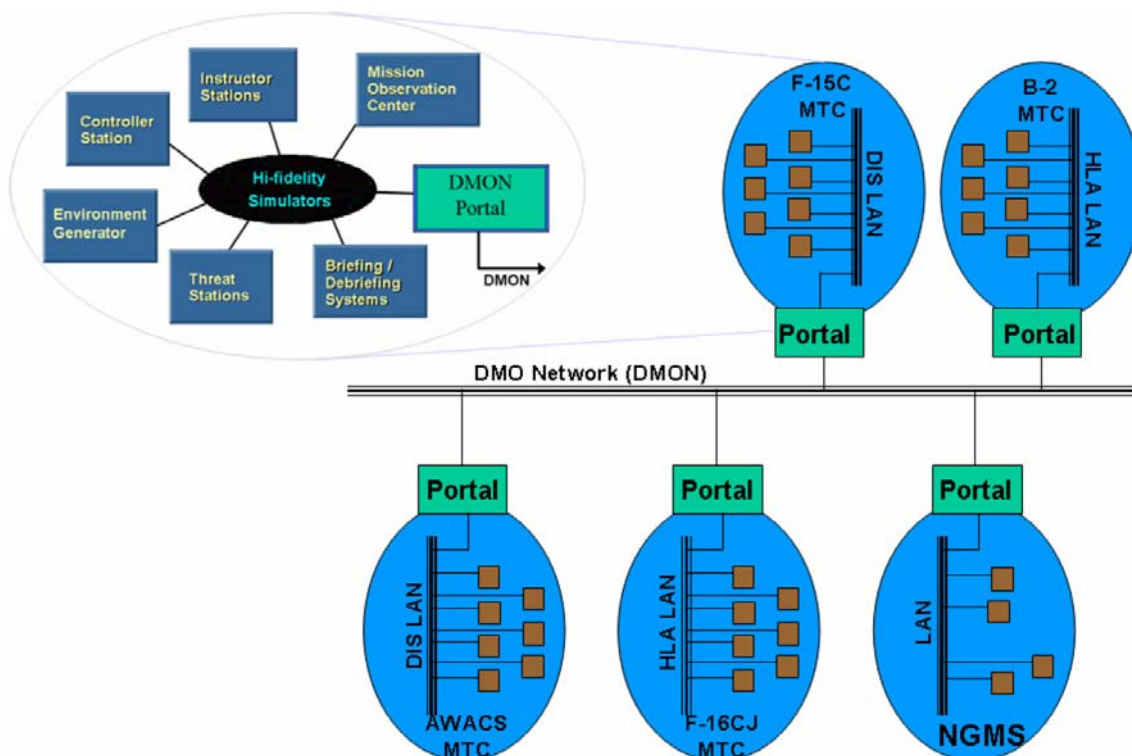

Figure 13 USAF Distributed Mission Operations (DMO) System Architecture

The Stream Manager receives standardised data packets and determines which Data Stream(s) each packet must be associated with. Packets are then duplicated and passed along to the Distributor for distribution among the remote MTC sites. With inbound simulation traffic to an MTC, the WAN Controller receives Portal Speak packets from all remote Portals listed in the configuration file. These packets are passed on to the Stream Manager to be routed to the proper LAN endpoint(s) based on the stream subscriptions. Once at the LAN endpoint, the packets are translated into the native MTC simulation protocol and sent to the network of the local MTC.

6.9 DMO Mission Training Centers (MTCs)

DMO MTCs are comprised of high fidelity man-in-the-loop virtual cockpits for pilots, weapon system officers, and C2ISR crew stations. These systems are complemented with additional training components which include manned threat stations, instructor-operator stations, environment generators, and Brief/De-brief solutions. All MTCs interface to the DMON via the Portal interface specification (i.e. the DMO Network Standard). The interface, process/procedures, and simulation protocols utilised by these DMO MTC system sites for distributed training are in accordance with the DMO standards.

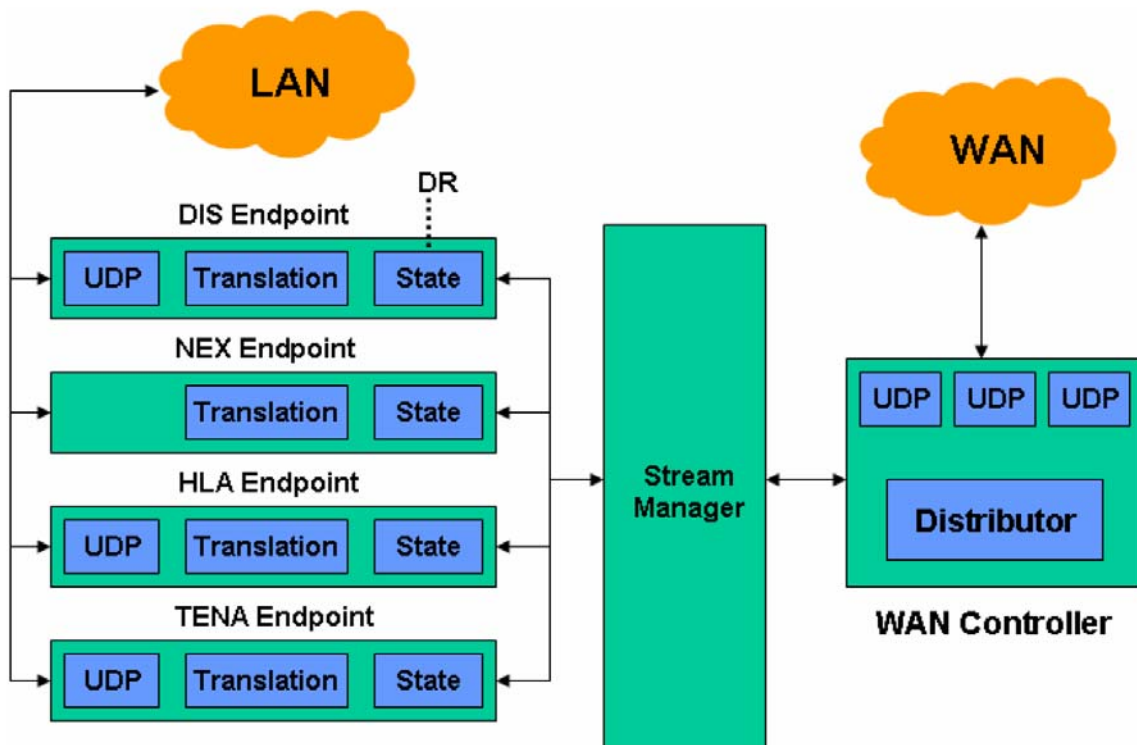

Figure 14 USAF DMO Portal Overview

The fast flyer sites (e.g. F-15C, F-15E, F-16CJ) typically contain four ownership simulators each with 360 degree visual display and an instructor operator system, four instructor threat

stations, four Computer Generated Forces Servers, a Ground Controlled Intercept/ Airborne Warning and Control Station, and a Brief/Debrief System.

C2 platforms (e.g. AWACS, JSTARS) typically match the operational aircraft to include the appropriate air crew/operator workstations for crew training, Instructor Operator Stations, and a CGF to populate the battlespace.

6.10 Section Summary

The objective of this section is to describe in some detail what the USAF DMO system is and why the RAAF needs to train using such systems.

The USAF DMO Program has been designed to enable multiple (now including coalition) LVC players at the same or multiple sites to participate in training scenarios ranging from individual and team sorties to full theatre-level battles.

The USAF DMO requires the implementation of DMO system standards by all DMO participants (eg MTCs) to achieve a plug-n-play type solution.

Section 6 also discusses some work that indicates that the most efficient way to train pilots is to use “an optimal mix” of Live and Virtual (i.e. LVC) training.

The main (technology) components of the USAF DMO Program are also described:

- The DMON network;
- The DMO Interoperability Standards;
- The DMO Integration and Testing Methodology;
- DMO Portals; and
- DMO Mission Training Centers.

7. Where to Now for the RAAF?

7.1 Coalition LVC Interoperability

Coalition operations are typical of modern warfare. Coalition DMO capabilities provide the flexibility to train and rehearse for all potential operations using advanced distributed LVC systems and processes [Hambleton].

USAF R&D efforts supporting DMO LVC capabilities continue to focus on technical interoperability with JNTC interoperability standards and efforts to establish a Joint Training Federation M&S Toolkit. The addition of coalition capabilities to DMO systems, organisations

and processes supports parallel efforts by USJFCOM to establish multi-national training with other countries and NATO. Some of the objectives for this work include:

- incrementally improving training capabilities as improvements/efficiencies are implemented;
- minimising duplication of R&D efforts; and
- enhancing simulation interoperability through standardisation and commonality.

The inclusion of multi-national forces in many USAF/Joint live exercises is now routine and recognises that USA Forces typically fly and fight as coalition forces. Adding coalition capabilities and procedures to DMO is a natural extension of those same training objectives into the distributed (now coalition) LVC training environment and potentially adds the final level of realistic training, in full coalition combat environments, to the continuum of small team and large force readiness. This would facilitate distributed mission rehearsal events to prepare units and personnel for deployed coalition operations at the tactical and operational levels of war and add depth to unit-level training. Currently, the USAF coalition DMO initiative is focused on achieving mission-level connectivity between virtual weapon systems simulators operating in an integrated and interoperable LVC environment. It is intended to complement and facilitate all of the ongoing efforts by US Forces, US Joint Forces Command (USJFCOM) and NATO to establish multi-national exercise architectures for joint coalition operational training [Hambleton].

The USAF regularly carries out various live “Flag” training exercises (Red Flag, Green Flag, Blue Flag, etc.) on various training ranges with various components of the USAF and other US Services. Although these Flag exercises are live training exercises they are starting to incorporate Virtual and Constructive LVC capabilities and components in an effort to cost-effectively bring more assets and realism to the relevant Flag exercises. Also these Flag exercises often include some form of coalition operations and participation.

7.2 Future Integration of Live LVC Coalition Systems

As mentioned previously USAF Live “Flag” training exercises are starting to incorporate Virtual and Constructive LVC capabilities and components in an effort to cost-effectively bring more assets and realism to the relevant Flag exercises.

Live DMO forces are integrated through the digital representation of their live (range) operations within the computer-generated LVC battlespace. This is typically accomplished through the use of instrumented pods or other range instrumentation systems (eg ACMI systems) that transmit aircraft performance information into the battlespace through ground stations as part of the exercise architecture. Currently such systems may only be uni-directional in that the LVC battlespace data may not be transmitted and represented in the onboard systems of the Live DMO systems and this may limit the training available.

Full future DMO LVC participation by coalition partners requires the future evolution of these instrumentation capabilities from uni-directional output of (aircraft) data into the integrated

LVC environment to the bi-directional exchange of data that includes the transmission of computer-generated threat arrays to all battlespace entities, including live weapon systems. Such environmental inputs to live players should stimulate appropriate threat warning systems, react to jamming and countermeasures, and be detectable by all land/sea/air/space/cyberspace sensors present in the joint exercise battlespace that are capable of such detections. These “virtual range” (i.e. Synthetic Range) capabilities are especially needed for electronic warfare mission elements that often suffer from limited threat capabilities on most ranges.

Systems that provide such LVC interoperability capabilities in Live systems are sometimes referred as Embedded or Integrated (LVC) Training Systems. The US DoD defines embedded training as “capabilities built into, strapped into, or plugged into operational systems”. Embedded training can occur through stimulation or simulation within the Operational Flight Systems or via a pod or other mechanism attached to the operational system. Legacy aircraft such as the F-16 may use a mobile range instrumentation system carried in a wing-mounted pod (Figure 15). However such “appended” pod systems may only be loosely coupled to the aircraft systems and may not actually be “Live” (i.e. real-time) and data may be stored on some sort of memory device that may need to be physically removed and downloaded on to a ground-station which is then used for After Action Review. However more modern fifth generation aircraft (eg the JSF or F-22) will have embedded (i.e. interoperable real-time) LVC training system capabilities permanently integrated within (i.e. tightly coupled to) the operational aircraft avionics systems [Peck].

When considering the potential for coalition mission rehearsal using advance capabilities against real adversaries,

RECOMMENDATION: all full mission virtual simulators should be coalition DMO capable by design with applicable CDS guards and associated rule sets in place.

In the near term, the bigger challenge is the cost of modifying existing legacy simulators to achieve the same multi-national capabilities [Hambleton].

Lechner and Huether [Lechner] provide an excellent discussion of three levels of interoperability that Live platforms can use to integrate (i.e. connect) into LVC training networks as follows:

1. ACMI Interoperability - Entails a uni-directional connection of a live platform to the training network. A typical instantiation would include aircraft positional data being reported onto the terrestrial training network via an ACMI (Air Combat Maneuvering Instrumentation) ground station. Additional connections from the live platform can include uni-directional tactical datalink messaging via a datalink-to-network bridge (e.g. Link16-to-DIS) and bi-directional voice communications. This level has value for ground-based training, but low value for live airborne training (i.e. – no feedback from the ground network to live platform).

2. **Command & Control Interoperability** – Adds to the previous level with the addition of bi-directional tactical datalink messaging. This methodology allows command and control data from the terrestrial network to be reported to the Live airborne platform. This level has high value for ground-based training and median value for Live airborne training. While this level does provide some ability to exercise threat avoidance, it lacks the ability for the live platform operator to perform sensor acquisition and targeting and exercise weapons deployment on virtual and constructive forces.
3. **DMO Interoperability** - Provides the most effective methodology in both training effectiveness and live training cost efficiency. Building on the previous two levels, this level entails bridging pertinent training data on the terrestrial network over a datalink to the Live airborne platform for training purposes. This level entails installing simulation systems, either on-board or via external carriage, that simulate/stimulate sensors and weapons to provide the operator with the ability to manage threat avoidance, perform sensor acquisition and targeting, and exercise weapons deployment in flight. Additionally, the platform must report precise position/orientation information, emissions, and weapons data to the terrestrial DMO network to participate within the external LVC environment. One of the most straight forward methods to implement this is for the live platform to replicate the DIS protocol.

Lechner and Huether describe a Boeing research project (a proof-of-concept demonstration) that developed a DMO compliant embedded training system LVC interface for a (Live) F-15E aircraft and used this embedded training interface to interoperate with a (Boeing built version of a) DMO LVC training network.

This F-15E DMO embedded training capability was then used to show the benefits of such a capability in a DMO distributed simulation environment demonstration including:

- Significant cost savings through reduced live aircraft resources;
- The ability to conduct multiple training scenarios in a single live flight without range restrictions on targets or threats;
- The ability to demonstrate operational use of (i.e. LVC stimulation of operational) sensors and avionics within a virtual / constructive environment; and
- Reduced mission setup time, allowing missions to be planned relative to a live aircraft and activated in real time.

The demonstration (Figure 15) that used an existing Beyond Visual Range (BVR) F-15E training syllabus scenario (to prove relevancy of the LVC demonstration) used the following entities:

- One live F-15E aircraft assuming the role of the lead friendly aircraft;
- One virtual F-15E manned simulator assuming the role of the friendly wingman aircraft;

- Four constructive enemy aircraft plus surface-to-air threats generated by the Boeing BigTac™ Computer Generated Forces package; and
- One weapons server to perform fly-out of missiles launched from the live platform.

The F-15E simulator and the Boeing BigTac CGF were run on a DIS IEEE 1278.1/A network. Entity updates and weapons firing data were communicated between the live F-15E and the simulation network via the Link-16 datalink. DIS PDU's were encapsulated into standard Link-16 message packets for transmission to and from the aircraft in order to fit within the prescribed message size on Link-16. The entity updates and weapon firing data were converted from encapsulated Link-16 DIS PDU's to DIS PDU's and vice versa by both the aircraft and a ground station gateway.

Radio communications interoperability between the live F-15E (real radio communications) and the on the virtual F-15E (DIS radio communications) was achieved using an ASTi radio communications gateway system [ASTi].

Presumably Link-16 interoperability was achieved using standard (DMO LVC) Link-16 interoperability mechanisms over the normal Link-16 network.

7.3 Virtual Flag Exercises

In Virtual Flag events, the DMO training audience is primarily operating in-house on geographically distributed full mission simulators linked to the DMOC through a variety of networks. Most of the US Air Force virtual simulators are interconnected through the Distributed Mission Operations Network (DMON) that provides on-demand connectivity and simulation services but other mission simulators and C² systems connect via the Joint Training & Experimentation Network (JTEN). The DMON can be used to conduct small team training amongst local simulators or it can connect to the DMOC where a federation of LVC systems can be used in support of larger scale Joint or Coalition Virtual Flag exercise events.

Coalition participation in Virtual Flag events is common but may be restricted from full distributed participation by security constraints. The Air Force Research Lab (AFRL) in Mesa, Arizona, works closely with the DMOC and several countries (eg Australia through DSTO) on coalition mission training research under cooperative research agreements.

7.4 Authority to (Inter)Operate

According to Hambleton et al. there are three key elements, each with technical, policy, and contractual implications, that are necessary to achieve the legal, security, and funding authorities to operate through which the successful establishment of coalition training operations will require [Hambleton].

7.4.1 The Legal Authority to Operate

Currently coalition DMO is conducted under the authority of a series of Research & Development (R&D) Program Arrangements (PAs) and separate nation-to-nation

Interoperability Arrangements. Formal R&D PAs related to coalition DMO are currently established between the Air Force Research Lab and corresponding technical research facilities in Australia (i.e. DSTO), Canada, New Zealand, the UK and Sweden. These R&D arrangements authorise the conduct of cooperative Coalition Mission Training Research (CMTR) to develop and test technical connectivity and cross-domain solutions (CDS) leading to secure and interoperable virtual simulator operations. Such arrangements may, or may not, be aligned with specific DMO training objectives. Interoperability Arrangements (IAs) give nations the legal authority to conduct DMO activities and use included systems for operational training. These bilateral IAs define the legal obligations for each party to be responsible for its own program security accreditation and costs. Both PAs and IAs are specifically intended to establish coalition DMO capabilities and they are mutually supportive [Hambleton].

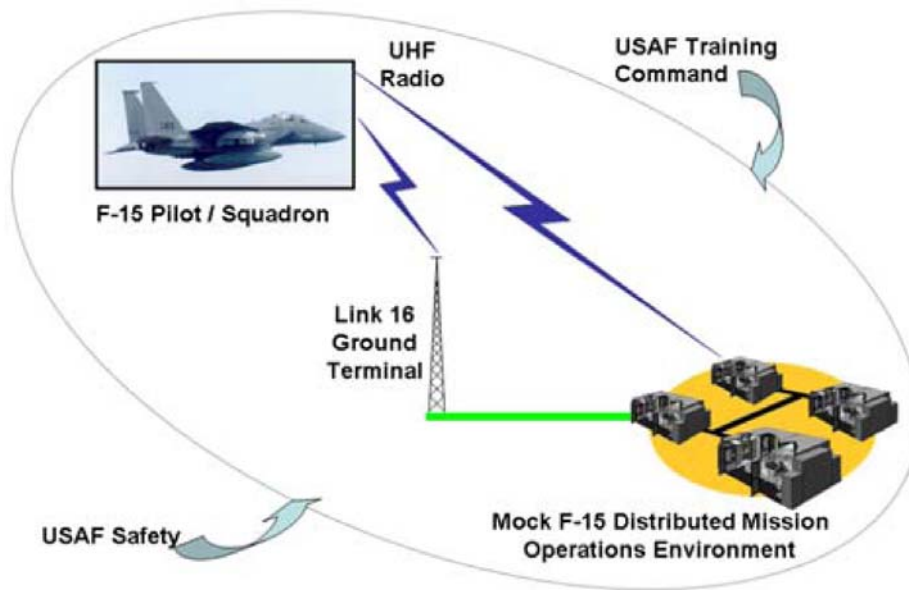

Figure 15 The Lechner and Huether F-15E DMO LVC Embedded Training Capability

7.4.2 The Security Authority to Operate

Each participating nation must be able to retain the ability to protect the unique technical capabilities of any of its national systems to the extent necessary. The determination of systems and data releasability and the development of robust data guards and other security technologies is a national responsibility. DMO systems and subsystems also require constant and detailed intrusion detection surveillance for vulnerabilities as they are initially tested, declared operational and technically reconfigured. These technical solutions must be coupled with the implementation of highly effective and practical security management standards, procedures, and practices. New or improved systems and networks and other changes will require security approval for each subsequent event. Processes and capabilities need to be developed that should help streamline and standardise the national and multi-national approval processes for granting the security authority to operate [Hambleton].

7.4.3 The Funding Authority to Operate

Coalition DMO is designed to deliver cost-effective and realistic multi-national LVC training. The challenge of designing viable integrated LVC training environments must be met by each nation's services and joint warfighters before they can interconnect to provide a true coalition multi-national training capability. For Air Forces, only part of the investment can be offset by trading flying hours for simulator hours and much of the value of using integrated LVC technologies is in cost avoidance and the improvement of training realism and readiness beyond the capabilities of current training methods. Each member nation must allocate sufficient funding to the R&D, security solutions, testing and exercise efforts before any of this work can begin [Hambleton].

7.5 Integration of LVC Systems

“Defence (the ADF) will adopt an approach where multiple small-steps, concurrent with some medium leaps, are taken towards the implementation of NCW. With each step, Defence will focus on ‘learning by doing’ [ADDP-D.3.1].

7.5.1 The DSTO (AOD) Net Warrior Initiative

The DSTO Net Warrior initiative was conceived to address, through experimentation, new and evolving network centric capabilities and mission system technologies to enhance ADF joint war fighting capabilities. With this as the prime objective, Net Warrior will be in part the realisation of a general ambition in DSTO to create a research network of (NCW enabled) Battlelabs [Filippidis (2009)].

Initially, the Net Warrior initiative has developed a network infrastructure to support a research capability in NCW by connecting a set of nodes which are test-beds representing current or potential future ADF assets [Lawrie], [Zalcman (2006)], [Zalcman (2007) - 2], [Zalcman (2008)]. The nodes were selected using the criteria of: a) the need for interoperability of the real assets; b) the significance of the real assets in joint operations; c) whether high fidelity representations of the assets exist or are planned in DSTO; and d) whether experimental representations of potential assets would benefit from participating.

The DSTO nodes will be high fidelity representations of airborne and maritime assets and will include AEW&C, ADGE and a future ship. These nodes already exist, in some form, but at present are not able to appropriately interoperate. Net Warrior interoperability standards do not currently exist. Higher fidelity test-beds will allow evaluation of real systems and investigation of technical issues. The test-beds will evolve in themselves as integral components of the Net Warrior network and as stand-alone components of research capabilities with platform centric research objectives. Where there is common interest, exercises will be run which involve all nodes or a subset of these nodes.

The Air Defence Ground Environment SIMulator (ADGESIM) [Blacklock (2006)], [Blacklock (2007)], [Zalcman (2005)], [Zalcman (2006)], [Zalcman (2008)], the Desktop Aircraft (i.e. F/A-

18) Cockpit Simulator (DACS) systems, and the AEW&C Mission System Testbed (MST) and the AEW&C High-Fidelity (WIRE – Wedgetail Integration and Research Environment) simulation system are all being developed within the DSTO Air Operations Division.

Both the ADGESIM and WIRE systems are based on real operational components – they are high-fidelity, stimulated systems.

The ADGESIM Air Defence Controller (i.e. Air Combat Officer) simulation system (which is used by the RAAF as their current Air Defence Controller training system – see Figure 16) is fully compliant with the (proposed) ADF Corporate Synthetic Range Interoperability Model shown in Table 14.

The DACS and WIRE systems are also being continuously developed to be compliant with the Table 14 Synthetic Range Interoperability Model. An objective of Net Warrior is to support DMO interoperability however there are no Net Warrior interoperability standards (i.e. a Net Warrior Synthetic Range Interoperability Model). The development of such a set of DMO compliant interoperability standards will accelerate the development of DMO compliant interoperability for the DACS and WIRE systems.

Once these DSTO AOD simulation systems are all compliant with such a set of interoperability standards (eg a Net Warrior Synthetic Range Interoperability Model) the AOD ADGESIM, DACS and WIRE (LVC) systems should all be highly interoperable with each other.

Since it is assumed that the Synthetic Range Interoperability Model defines a set of (distributed simulation, radio communications and tactical data link) interoperability standards that should be very similar to the interoperability standards used by the USAF DMO Program the recommended ADF Corporate Synthetic Range Interoperability Model compliant AOD simulations systems should then also be highly interoperable with USAF DMO compliant simulation systems.

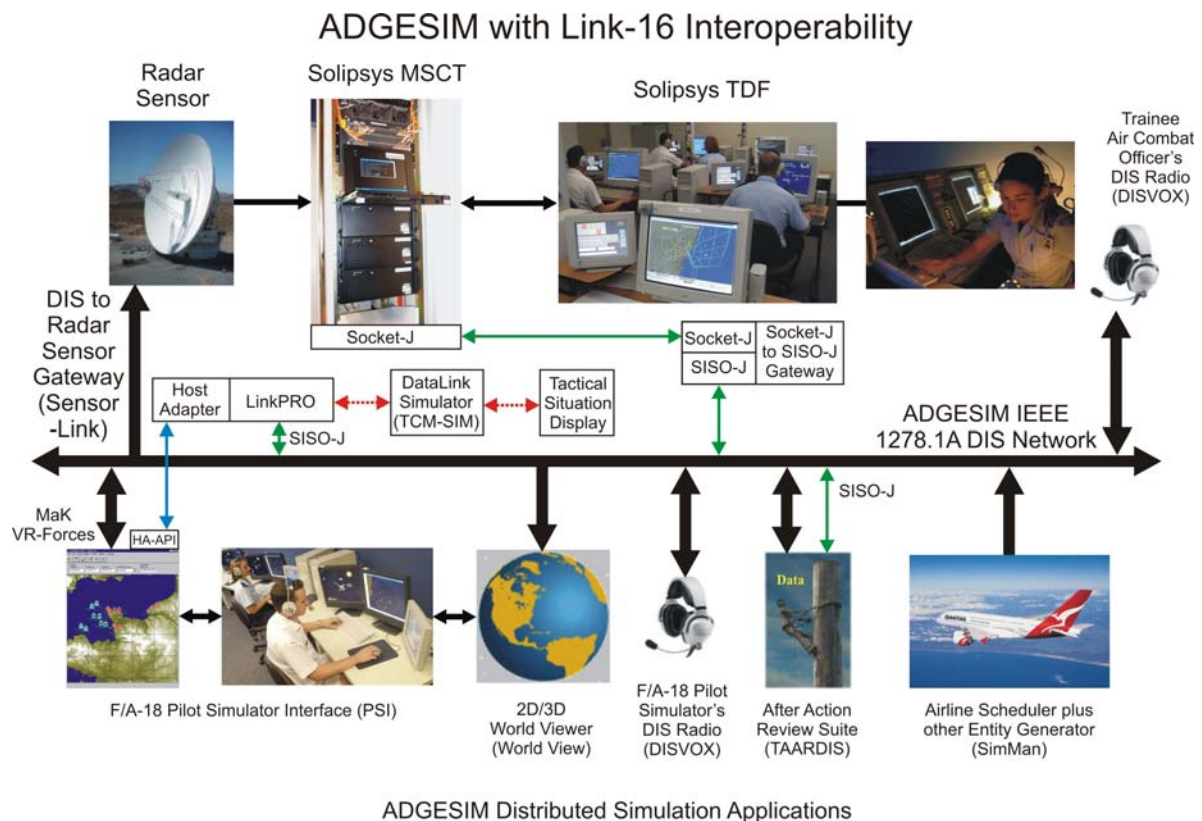

Figure 16 The Synthetic Range Interoperability Model Compliant ADGESIM

7.5.2 What Are Mission Training Centres?

The AOD simulation systems (the ADGESIM, DACS and the AEW&C WIRE systems) could be connected together on a (i.e. the Net Warrior) network to form a DMO compliant, AOD Air Battle Management, Mission Training Centre.

Mission Training Centres (MTCs) are generally comprised of components including:

- High-Fidelity Simulation systems - may be Human-In-the-Loop (HIL) virtual simulation systems (F-15, F-16, etc), C2ISR crew stations (AWACS, JSTARS, etc), weapon system officers crew stations, etc. These high-fidelity systems may be either stimulated real, operational component systems or emulated systems;
- Ancillary components such as manned threat stations, Computer Generated Forces packages, command and control stations, etc. to populate the battlespace to provide a realistic synthetic environment; and
- Exercise management systems such as instructor-operator stations, Brief/De-brief stations, Loggers etc.

USAF MTCs interoperate from base to base via the DMO Network (DMON) which is a persistent, classified, Wide-Area-Network that provides global MTC connectivity and control of the whole DMO system via standards-based protocols [Lechner]. Operational USAF Mission Training Centres have been in use for more than a decade.

7.5.3 An AOD Mission Training Centre Capability Concept Demonstrator

The DSTO Air Operations Division has sufficient simulation system components, expertise and experience to develop a DMO compliant Mission Training Centre (MTC) Capability Concept Demonstrator (CCD) similar to that developed by the UK MOD Mission Training through Distributed Simulation (MTDS) programme.

The objective of such an AOD MTC CCD will be

- To study various elements of Joint and Coalition synthetic Live-Virtual-Constructive (LVC) training to provide guidance on technical and operational issues to assist the RAAF to migrate towards a highly interoperable, LVC corporate synthetic environment (Synthetic Range) to enable a training focused, DMO compliant RAAF MTC (proposal) to be developed;
- To do experimentation, research and development to help the ADF and RAAF develop corporate interoperability standards based on the USAF DMO standards. These standards (the Synthetic Range Interoperability Model) will form the distributed simulation infrastructure (i.e. the standards based approach) upon which the AOD MTC CCD (and the RAAF MTC) will be developed. This work will also reduce risk and cost when acquiring future LVC components, training systems and operational platforms with LVC capabilities; and
- Test, evaluate and/or develop re-usable LVC components (Blue, Red and White Forces CGF applications, Loggers, After-Action-Review applications, etc) which could be used (i.e. re-used) to reduce cost and risk for current and future ADF and RAAF training systems and future operational platforms with LVC interfaces.

Some example NATO “Use Cases” involving LVC systems given to illustrate the importance of integrating Live Simulation (section 2.3.4) in both training and simulation environments [Gustavsson] include:

- Extended Air Defence Simulation - Several types of real operational sensors (radar) airborne/ground-based Air Defence systems fed with a synthetic environment including aircraft and ballistic and cruise missiles;
- Composite Air Operations (COMAO) - Large number of aircraft and air/ground defence to be able to attack certain targets. In the future live aircraft and sensors including AWACS with real pilots/real operators;
- Close air support/Indirect fire support - Training of the Forward Air Controller/Forward part in a live environment; and

- Training In Real C2 System Environments - In many of the above examples of training and simulation examples where real operational C2-systems interoperating with other live operational systems.

RAAF Air Battle Management (ABM) teams are responsible for the tactical command and control of all air assets in the battlespace and are typically comprised of a Tactical Director and a number of Fighter Controllers. The Tactical Director allocates assets and manages operations within the air battle, overseeing and directing the Fighter Controllers, and communicates with other command elements and external agencies. The Fighter Controllers liaise with pilots in order to direct aircraft in accordance with instructions, procedures, the tactical plan, and as directed by the Tactical Director [Shanahan].

Some AOD simulation systems that could support the above example *Use Cases* and could form the basis of a DMO compliant, AOD Air Battle Management, MTC CCD could include:

- A Ground Based Air Defence system - The Air Defence Ground Environment SIMulator (ADGESIM) is the actual high-fidelity (stimulates the real, operational software used by the RAAF) training system used to train RAAF Air Combat Officers which has been completely developed at DSTO;
- A Fighter Aircraft system - The Desktop Aircraft Cockpit Simulator (DACS) is being developed at the AOD Air Operations Simulation Centre (AOSC); and
- An Airborne Early Warning & Control (AEW&C) aircraft (AWACS like aircraft referred to as Wedgetail) system - The Wedgetail Integration and Research Environment (WIRE) is a high-fidelity representation (it is a stimulated, real operational AEW&C mission system) of the user interface used in the real AEW&C aircraft.

An AOD, Air Battle Management, Mission Training Centre Task should be developed within AOD as the ADGESIM, DACS and AEW&C WIRE systems are all AOD LVC systems. One of the problems with Net Warrior is that inter-Divisional LVC simulation systems interoperability is not directly funded and neither is it high priority for individual DSTO Divisions. Inter-Divisional LVC simulation system interoperability is generally treated as low priority and this impedes (LVC interoperability) progress considerably - this is why it is important (i.e. very convenient) that the systems under development are all controlled by a single DSTO Division i.e. AOD.

The first step to building such a capability is to further develop an appropriate Corporate Synthetic Range Interoperability Model and to then develop the AOD ADGESIM, DACS and the AEW&C WIRE systems to be compliant with this Synthetic Range Interoperability Model.

These AOD systems can then be connected over the persistent classified (Net Warrior) network between AOD FB and AOD Edinburgh that has already been (or will shortly be) developed as part of the Net Warrior initiative.

It is the intention of the authors of this report to produce a DSTO Report on the development of an AOD Air Battle Management Mission Training Centre in the near future.

7.5.4 A RAAF Air Battle Management Mission Training Centre

The objective of the AOD MTC CCD will be to study various elements of Joint and Coalition synthetic Live-Virtual-Constructive (LVC) training to help provide guidance on technical and operational issues to assist the RAAF to migrate towards a highly interoperable, LVC corporate synthetic environment (Synthetic Range) to enable a training-focused, DMO compliant RAAF MTC to be proposed and developed.

Such a RAAF, Air Battle Management, Mission Training Centre facility could be used to help the RAAF develop:

- Cost-effective coalition, DMO training; and
- Experimentation, research and development of future operational capabilities;

thereby addressing the significant gap that currently exists between training obtained using stand-alone simulators and training obtained using live training exercises for combat crews.

In 2005 the UK's Ministry of Defence established a Capability Concept Demonstrator (CCD) as the first phase of its Mission Training through Distributed Simulation (MTDS) Program. The 30 month CCD program aimed to de-risk the UK MTDS program by establishing user requirements through a series of demonstration events on a contractor owned facility at RAF Waddington. These user requirements were to have been used to underpin the MoD's future competition for delivery of the full UK MTDS program [Saltmarsh].

The CCD facility initially comprised a network of fast jet cockpit simulators and an Airborne Warning and Control System (AWACS) simulator networked together through a comprehensive exercise management and control room with an integrated planning, briefing and debriefing suite to support the aircrew learning experience. The system was also provided with a secure networking and encryption room to allow it to be connected to other training systems around the world.

The training to be delivered was not designed to teach trainees how to operate their equipment; this was taken as a pre-requisite. Instead it taught how to use the full range of equipment in a realistic operational environment to maximise the individual's effectiveness as part of a team and the wider military operation.

The CCD was originally contracted to deliver 8 weeks of activity over a period of 30 months. At the end of this period (and the initial funding) the CCD Program captured a considerable amount of information related to requirements for UK MTDS, and it achieved connectivity and interoperability to the USAF DMON and it resulted in the UK MoD establishing a major new funding line for aircrew collective training.

The RAF and UK Army chose to advance their procurement plans. They agreed to convert the original Research and Development CCD facility to a training capability, based on the technology used in the CCD facility, to deliver mission specific training to UK Land forces before they embarked for operations in Afghanistan.

The original requirement of the CCD facility to deliver 8 weeks of activity over a 30 month period with no requirement for reliability was extended to 44 weeks per year of training and research activity for an additional period of four years at a defined level of availability.

The physical layout and capability of the system was to be enhanced considerably – the 40 participant briefing and de-briefing capability was doubled in size, the five E-3C simulator consoles were expanded to ten E-3D AWACS consoles, etc. The final training facility was to be run by less skilled simulator operators and technicians who had never been involved in the system. This required an appropriate standard of documentation and a system that performed in a well defined and stable way.

The AOD Air Battle Management Mission Training Centre discussed above could be further developed into a RAAF Air Battle Management Mission Training Centre.

Initially the RAAF capability would be comprised of similar components (ADGESIM, DACS, AEW&C MST and WIRE, low cost Blue and Red Forces, CGF White Forces, Loggers, After-Action-Review, etc) to those found in the AOD Air Battle Management Mission Training Centre.

Providing connectivity to, and interoperability with, the co-located RAAF Williamtown high-fidelity training systems (ADGESIM, AEW&C OMS, Super Hornet training systems, etc) would enable these trainers to participate (as part of a RAAF Air Battle Management Mission Training Centre) in Joint or Coalition LVC training that:

- May not be able to be done at all using real operational platforms – too dangerous;
- May only be able to be done rarely using operational platforms – too expensive and difficult to get all the required resources (Live platforms, manpower, etc.) together; or
- May only be able to be done using (RAAF high-fidelity) simulators - experimentation.

Although each individual high-fidelity training system at RAAF Williamtown (ADGESIM, AEW&C OMS, Super Hornet training systems, etc) will be able to train using their own self contained systems each system will not have a high-fidelity representation of the other systems.

For example - Live RAAF training which may require many platforms (eg AEW&C, 4 blue force fighter platforms versus 8 red force fighter platforms (13 Live platforms)) may be most cost-effectively done in simulation using the high-fidelity training simulation systems at RAAF Williamtown in a RAAF, Air Battle Management, Mission Training Centre. The Live flying hours saved may be more efficiently used by extending Live coalition training flying hours as the opportunity to train with many Live coalition platforms may only occur rarely.

Also in the future when coalition Live training becomes coalition LVC training the RAAF, Air Battle Management, Mission Training Centre high-fidelity systems may be able to participate in the same training exercises as the Live platforms thereby multiplying the effect (i.e. efficiency of being able to provide realistic training for more people) of the Live (i.e. LVC) training.

Such a RAAF Air Battle Management Mission Training Centre would be a new capability for the RAAF.

7.6 Section Summary

Section 7 focuses on the future for the RAAF and how AOD can help the ADF and RAAF move forward.

Hambleton et al. recommend that

all full mission virtual simulators should be coalition DMO capable by design with applicable CDS guards and associated rule sets in place.

However to end up with full mission virtual simulators that have a suitable (i.e. useful) level of (“out-the-box”) LVC interoperability requires that a precisely and unambiguously defined ADF Corporate Synthetic Range Interoperability Model be developed or available.

How (future) Live platforms with embedded DMO LVC interfaces can be included in LVC coalition DMO networks has also been discussed.

The concept of an AOD, Air Battle Management Mission Training Centre, Capability Concept Demonstrator is introduced with the potential to morph into a training-focused, USAF DMO compliant, RAAF Air Battle Management, Mission Training Centre. Such a new RAAF capability would enable the RAAF to participate in future coalition LVC training using a combination of high-fidelity full mission virtual simulators and real platforms with embedded LVC interfaces thus enhancing the RAAF’s training capabilities.

8. Conclusions and Recommendations

Today (in the US) simulation technology allows warfighters to participate in a continuous training cycle and maintain a high state of combat readiness by using cost-effective simulation alternatives in conjunction with live-fly operations and training missions. Current development of live, virtual, and constructive (LVC) systems for training and mission rehearsal, the rapid advancement of networking technologies and protocol standards/architectures such as Distributed Interactive Simulation (DIS) and High Level Architecture (HLA) have all contributed to an environment where highly-distributed training, mission rehearsal, operations support, and multi-force Distributed Mission Operations (DMO) joint/coalition exercises have become an every day reality [Portrey].

The USAF DMO Program enables multiple LVC players at the same or multiple sites to participate in training scenarios ranging from individual and team sorties to full theatre-level coalition battles.

Some key points of the DMO system are:

- Training is available 24/7;
- All training systems must comply with a rigid set of interoperability standards;
- MTCs provide high-fidelity, man-in-the-loop platform simulators, friendly and adverse forces;
- Multiple/simultaneous training events are supported; and
- Lead time is 1 hour for archived scenarios.

The primary elements of the CAF DMO architecture include the DMO Network, Interoperability Standards, the DMO Portal, and Mission Training Centers.

Coalition DMO is designed to deliver cost-effective and realistic multi-national LVC training. In the USAF approximately 20% of F-15C Live training will be done in DMO simulation systems.

In Australia the RAAF makes no use of any LVC DMO capability whatsoever!

No ADF or RAAF LVC corporate interoperability standards exist!

Live platform training can provide enhanced training but it can also be extremely expensive and require considerable human resources to organise. Live platform training can be inefficient. A significant gap exists between training obtained using stand-alone simulators and training obtained during live training exercises for combat crews. A mixture of Live and Virtual training may be the optimal way to train.

An increasing portion of combat training for new weapons and combat systems (F-22, JSF, etc) can only be accomplished in high-fidelity networked (LVC) simulators.

Live weapons cannot be fired at Live platforms during training.

Platform development by experimentation can only occur in networked simulators as the platform being developed may not yet exist!

Developing people functionality (i.e. determining new roles) may be able to be done most efficiently in a network of LVC simulation systems.

Unless the RAAF adopts new technologies such as DMO LVC training systems it will become more difficult and expensive to participate in coalition training and maintain minimum levels of mission readiness.

Other coalition Air Forces are developing LVC interoperability with USAF DMO systems to advance coalition training. It seems logical for the RAAF to proceed in the same direction and strive to develop coalition LVC interoperability with the USAF in order to be able to easily and cost-effectively participate in future coalition LVC training exercises.

Efficient LVC training relies on having an appropriate set of interoperability standards, processes and common databases in place. These are (slowly i.e. very slowly) being developed by the ADF, RAAF and DSTO. However this standardisation process could be fast tracked by obtaining and/or implementing the same or similar interoperability standards, processes, common databases and applications as are used by the USAF DMO Program.

AOD currently has a Project Arrangement [PA-25] with the USAF on “Collaborative Distributed Mission training Effectiveness Research”.

“The overall objective of PA-25 is to conduct behavioural and technical research to increase the effectiveness and range of applications of Distributed Mission Training (DMT) for national and coalition force operations. DMT research activities will involve USAF and RAAF personnel operating real-time, warfighter-in-the-loop (virtual) simulation systems supported by computer generated (constructive) simulations operating either locally or linked while separated by intercontinental distances” [PA-25].

RECOMMENDATION 1: It is recommended that AOD request the USAF DMO LVC interoperability standards documentation discussed in section 6 (i.e. section 6.6) to advance the work carried out under PA-25.

RECOMMENDATION 2: It is recommended that AOD support (i.e. Task and Fund) an AOD Air Battle Management Mission Training Centre Capability Concept Demonstrator that builds on the work and network infrastructure already carried out and developed within AOD.

This work will initially task the AOD ADGESIM, DACS and AEW&C WIRE LVC systems to;

1. Implement interoperability standards compliant with the recommended ADF Corporate Synthetic Range Interoperability Model (still being developed) and the Interoperability Model used by USAF DMO LVC systems (which should be very similar if not identical); and
2. Interoperate using the classified, secure and persistent network infrastructure developed and put in place between AOD FB and AOD Edinburgh by the Net Warrior initiative. This network infrastructure could/will be used for future (DSTO) coalition LVC experimentation (i.e. research and development).

RECOMMENDATION 3: It is recommended that AOD develop an AOD, Air Battle Management Mission Training Centre Capability Concept Demonstrator. This AOD, Air Battle Management Mission Training Centre Capability Concept Demonstrator will be used to study various elements of Joint and Coalition synthetic environment LVC training to provide guidance to the RAAF on technical and operational issues to enable a training focused RAAF Air Battle Management Mission Training Centre based at RAAF Williamtown to be developed to give the RAAF a new, highly interoperable, DMO compliant, LVC coalition training capability.

RECOMMENDATION 4: All full mission RAAF virtual simulators should be coalition DMO capable by design (i.e. be compliant with the recommended ADF Corporate Synthetic Range Interoperability Model and the USAF DMO set of interoperability standards discussed in section 6 as per RECOMMENDATION 1 above) with applicable CDS guards and associated rule sets in place.

9. References

[AAP 1000-F] – Australian Air Power Publication AAP 1000-F, (2007) – “The Future Air and Space Operating Concept”, Available from Air Power Development Centre, Tuggeranong, ACT 2900 – www.raaf.gov.au/airpower

[ADDP-D3.1] - Australian Defence Force Doctrine Publication - D.3.1 – “Enabling Future Warfighting : Network Centric Warfare – Edition 1 (ADDP-D.3.1” February, 2004. Available from http://web-vic.dsto.defence.gov.au/dsto/research/ncw/ADDP-D_3_11.pdf

[ADF DI(G) OPS 42-1] - Defence Instructions (General), OPS 42-1, Defence Simulation Policy (2001), Canberra ACT 2600 AUSTRALIA: Australian Department of Defence.

[Aldinger] – Aldinger, M. and Keen, S. (2007), “CAF DMO Standards-Based Approach for Achieving M&S Interoperability”, NATO Modelling and Simulation Group Conference (MSG-056) “Improving M&S Interoperability, Reuse and Efficiency in Support of Current and Future Forces”, Prague, Czech Republic, October 2007.

[Ales] - Ales, R. and Buhrow, S. (2006) “The Theater Air Ground System Synthetic Battlespace”, Proceedings of the I/ITSEC 2006 Conference, Orlando, Florida, USA, November 2006.

[ASTi] - www.asti-usa.com

[Beattie] - Beattie, D. (2009), “A Case of Simulator Interoperability In Mission Training Through Distributed Simulation”, Proceedings of the SimTecT2009 Conference, Adelaide, Australia, June 2009.

[Berry] - Berry, A., (2004), “Lessons Learned From Virtual Flag Integration”, Proceedings of the 2004 Fall Simulation Interoperability Workshop, Orlando, Florida, USA, September 2004, 04F-SIW-090.

[Blacklock (2007)] - Blacklock, J. and Zalzman, L., (2007) “A Royal Australian Air Force, Distributed Simulation, Training and Experimentation, Synthetic Range Environment”, Proceedings of the I/ITSEC 2007 Conference, Orlando, Florida, USA, November 2007.

[Blacklock (2006)] - Blacklock, J. and Zalzman, L., (2006) “The Royal Australian Air Force Air Defence Ground Environment Simulator”, Proceedings of the SimTecT2006 Conference, Melbourne, May 2006.

[Chapman] - Chapman, R. (2006) “Accreditation Policy and Practice for Immersive Warfighter Simulators”, Proceedings of the I/ITSEC 2006 Conference, Orlando, Florida, USA, November 2006.

[Clark (1999)] - Clark, P., Pongracic, H., Cross, M., Morton, J. and Fulton, J. (1999) "Incorporating Intelligent Computer Generated Forces in a Human-in-the-Loop Simulation: Phase One – Establishment of a Research Testbed", DSTO Technical Report DSTO-TR-0889, October, 1999.

[Clark (2004)] - Clark, P., Ross, P. and Poustie, S. (2004) "An Analysis of Computer Generated Forces Packages for Distributed Simulation", DSTO Technical Report DSTO-TR-1607, August, 2004.

[Clark (2006)] - Clark, P., Ross, P., Oliver, W., MacDonald, R., and MacNeill, M., (2006) "Coalition Fleet Synthetic Training", Proceedings of the SimTecT2006 Conference, Melbourne, May 2006.

[Clark (2007)] - Clark, P. (2007) "Coalition Fleet Synthetic Training", Proceedings of the Langkawi International Maritime and Aerospace Conference (LIMA07), Singapore, May 2007.

[Cochrane] - Cochrane, D. (2004), The Necessity for Distributed Mission Training in Meeting Future Canadian Air Force Flying Requirements, CSC: Master in Defence Studies (2004), <http://wps.cfc.forces.gc.ca/papers/csc/csc30/mds/cochrane.pdf>

[Colegrove] - Colegrove, C., Rowe, L., Allinger, G., Garrity, M. and Bennett, W., (2009) "Defining the Training Mix – Sorties, Sims and Distributed Mission Operations", Proceedings of the I/ITSEC 2009 Conference, Orlando, Florida, USA, November 2009.

[Cubic] - www.cubic.com

[Daly] - Daly, M. and Thorpe, D, (2009) "Balancing Simulated and Live Naval Fleet Training", Proceedings of the I/ITSEC 2009 Conference, Orlando, Florida, USA, November 2009.

[de Anda] – de Anda, D., Cobb, C., and Sorroche, J. (2009), "Distributed Warfare Center Increase/Enhance/Augment Combat Readiness", Proceedings of the 2009 Spring Simulation Interoperability Workshop, San Diego – Mission Valley, CA, USA, March 2009, 09S-SIW-084.

[DIS (1995)] - IEEE Standard – Protocols for Distributed Interactive Simulation Application (1995), IEEE 1278.1.

[DIS (1998)] - IEEE Standard – Protocols for Distributed Interactive Simulation Application (1998), IEEE 1278.1A.

[DLS] - <http://www.rockwellcollins.com/dls/platforms/index.asp>

[Dudfield] – Dudfield, H., Kearse, J., McAuliffe, C., Watson, S., Gehr, S., and Clark, W. (2009), "The Impact of Fidelity Levels On Distributed And Collocated Fast Jet Participants During Multinational Collective Training", Proceedings of the SimTecT2009 Conference, Adelaide, Australia, June 2009.

[Filippidis (2007)] - Filippidis, A., Doan, T., and Tobin, B. (2007), "Net Warrior – DSTO Battlelab Interoperability", Proceedings of the SimTecT2007 Conference, Brisbane, June, 2007, pp 93 - 98.

[Filippidis (2009)] - Filippidis, A., Gencarelli, M., Tobin, B. and Zalzman, L. (2009), "Battlelab Interoperability: Applying the Synthetic Range Concept Through Net Warrior", DSTO Technical Report, DSTO-TR-2262, April, 2009.

[Grant] - Grant, S. and Johnsrude, E. (2009) "Towards a Concept of Operations for Distributed Training Simulation in the Canada Air Force", Proceedings of the I/ITSEC 2009 Conference, Orlando, Florida, USA, November 2009.

[Grevin] - Grevin, J. and Sorroche, J. (2007), "Creating a Distributed Synthetic Battlespace for Joint Warfighter Training", Proceedings of the 2007 Fall Simulation Interoperability Workshop, Orlando, FL, USA, September 2007, 07F-SIW-111.

[Gresche] - Gresche, D. et al, (2006), "International Mission Training Research – Communications and Connection Technologies in a Collaborative Environment", Proceedings of the 2006 European Simulation Interoperability Workshop, Stockholm, Sweden, June 2006, 06E-SIW-050.

[Gustavsson] - Gustavsson, Per M., Bjorkman, U., and Wemmergard, Joakim., (2009), "LVC Aspects and Integration of Live Simulation", 2009 Fall Simulation Interoperability Workshop, Orlando, Florida, September 2009, 09F-SIW-090.

[Hambleton] - Hambleton, O. and Lollar, G., (2008), "USAF Coalition Distributed Mission Operations (DMO): Achieving Multinational Full Mission Training In Integrated LVC Environments", Proceedings of the 2008 European Simulation Interoperability Workshop, Edinburgh, Scotland, June 2008, 08E-SIW-045.

[HLA (2000) - 1] - Modeling and Simulation Standard - High Level Architecture (HLA) – Framework and Rules, IEEE 1516-2000.

[HLA (2000) - 2] - Modeling and Simulation Standard - High Level Architecture (HLA) – Federate Interface Specification, IEEE 1516.1-2000.

[HLA (2000) - 3] - Modeling and Simulation Standard - High Level Architecture (HLA) – Object Model Template Specification, IEEE 1516.2-2000.

[HLA (2003)] - Recommended Practice for High Level Architecture (HLA) – Federation Development and Execution Process, IEEE 1516.3-2003.

[Khetia (2009) -1] - Khetia, S., (2009) "Enabling Distributed Mission Training", Proceedings of the I/ITSEC 2009 Conference, Orlando, Florida, USA, November 2009.

[Lawrie] – Lawrie, G. et al., (2007) "Net Warrior Concept of Operations", Draft Version 1.3.1, DSTO Technical Report, July, 2007.

[Lechner] - Lechner, R. and Huether, C. (2009) "Integrated Live Virtual Constructive Technologies Applied to Tactical Aviation Training", Proceedings of the I/ITSEC 2008 Conference, Orlando, Florida, USA, November 2008.

[Liebert] - Liebert, R. et al, (2006), "Technical Aspects of the Multi-Service Distributed Environment to Support Joint Test and Evaluation", Proceedings of the 2006 Spring Simulation Interoperability Workshop, Huntsville, AL, USA, April 2006, 06S-SIW-061.

[Ludwig] - Ludwig, A., Kilby, K., and Khetia, S. (2009), "A Demonstrator of Mission Training Through Distributed Simulation: Lessons Learnt in Linkages to National and International Networks", Proceedings of the SimTecT2009 Conference, Adelaide, Australia, June 2009.

[MacDonald] - MacDonald, R. and McCulloch, F. (2008), "Multi National Navy Synthetic Training - a Team Approach", Proceedings of the SimTecT2008 Conference, Melbourne, May, 2008, pp 135.

[MaK] - www.mak.com

[MIL-STD-3011] - MIL-STD-3011, "Interoperability Standard for the Joint Range Extension Application Protocol (JREAP)", 30 September, 2002.

[NATO M&S Vision] - 5000 TC-701/TT-2368/Ser: NU0007, (2008), NATO Allied Command Transformation Modelling and Simulation Vision, December 2008.

[NATO NMSSP] - AMSP-01(A), (2009), NATO Modelling and Simulation Standards Profile, December 2009.

[Nielsen] - Nielsen, M., Staal, O., Brathen, K., and Mevassvik, O. (2008), "Joint Air Defence Training Simulation (JADE) II - Reuse and Interconnection of Stand-Alone Training Simulation Systems Enabling Joint Tactical Training", Proceedings of the 2008 Spring Simulation Interoperability Workshop, Rhode Island, USA, April 2008, 08S-SIW-056.

[O'Connor (2006)] - O'Connor, M., DiCola, J., Sorroche, J., Lane, J., Lewis, D. and Norman, R., (2006), "A Mixed Architecture for Joint Testing", Proceedings of the 2006 Spring Interoperability Workshop, Huntsville, AL, USA, April 2-7, 2006, 06S-SIW-074

[O'Connor (2004)] - O'Connor, M. and Clardy, T., (2004) "SEIT: A Mixed Network Architecture to Support Distributed Testing", Proceedings of the 2004 Spring Interoperability Workshop, Arlington, VA, USA, April 18-23, 2004

[PA-25] - Project Arrangement (Serial Number AF-03-0025) on "Collaborative Distributed Mission Training Effectiveness Research" between the Government of the United States of America and the Government of Australia, 2003

[Padilla (2007)] – Padilla, S., (2007), “Providing Distinct Domains for Multiple Joint Players in a Large Scale Battlespace Exercise using Distributed Interactive Simulation (DIS) Filtering”, Proceedings of the 2007 Fall Simulation Interoperability Workshop, Orlando, FL, USA, September 2007, 07F-SIW-020.

[Padilla (2008)] – Padilla, S., Goodyear, C. and Massey, D. (2008), “The DMOC Replay Tool, an Exercise in COTS and GOTS Together in a Single System”, Proceedings of the 2008 Spring Simulation Interoperability Workshop, Providence, Rhode Island, USA, April 2008, 08S-SIW-021.

[Peck] - Pitz, R. (2009), “Sharing Lessons Learned During Mission Training Through Distributed Simulation: After Action Review Process and Technologies”, Proceedings of the SimTecT2009 Conference, Adelaide, Australia, June 2009.

[Pitz] – Peck, M. (2009), “A Question of Definition”, Training and Simulation Journal, October/November, 2009.

[Portrey] - Portrey, A., Bennett, W., Colegrove, C. and Schreiber, B. (2007), “DMO Today and Tomorrow: Science and Technology Support for Competency Based Training and Ops”, Proceedings of the 2007 Spring Simulation Interoperability Workshop, Norfolk, VA, USA, March 2007, 07S-SIW-072.

[Read] - Read, J. and Kent, J. (2007), “The Use of MOD Architecture Framework Views in Support of Verification and Validation of Synthetic Environments”, Proceedings of the 2007 Fall Simulation Interoperability Workshop, Orlando, FL, USA, September 2007, 07F-SIW-109.

[Ross] - Ross, P. and Clark, P. (2005), “Recommended Acceptance Testing Procedure for Network Enabled Training Simulators”, Proceedings of the SimTecT2005 Conference, Sydney, Australia, May 2005.

[RPR-FOM] - RPR-FOM - Guidance, Rationale and Interoperability Manual for the Real-Time Platform Reference Federation Object Model (RPR-FOM) – Version 2.0D17v3 (2003), <http://www.sisostds.org/>

[Rumpel] - Rumpel, B., and Vila, R., (2007), “Distributed Training in Europe”, Proceedings of the I/ITSEC 2007 Conference, Orlando, Florida, USA, November 2007.

[Ryan] - Ryan, P., Clark, P., Ross, P. & Fairlie, M. (2006), “Interoperable Aerospace Training Simulators Within The ADF”, Proceedings of the SimTecT2006 Conference, Melbourne, Australia, May 2006.

[Saltmarsh] - Saltmarsh, J. and Beattie, D., (2009) “Distributed Synthetic Air-Land Training – Demonstration to Delivery”, Proceedings of the I/ITSEC 2009 Conference, Orlando, Florida, USA, November 2009.

[Shanahan] – Shanahan, C., Best, C., Finch, M., Stott, A., Tracey, E. and Hasenbosch, S., (2009), “Exercise Black Skies 2008: Enhancing Live Training Through Virtual Preparation”, DST Research Report DSTO-RR-0344, November, 2009.

[SISO] - SISO Standard for LINK 16 SIMULATIONS, SISO-STD-002-2006, www.sisostds.org

[Solipsys] - www.solipsys.com

[Sorroche] - Sorroche, J., (2005), “Live, Virtual, and Constructive Asset Merge For Joint Red Flag”, Proceedings of the 2005 Fall Simulation Interoperability Workshop, Orlando, FL, USA, September 2005, 05F-SIW-106.

[STANAG 5602] - NATO Standardization Agreement (STANAG) 5602 “Standard Interface for Multiple Platform Link Evaluation (SIMPLE)”, Edition 1, 20 February, 2001.

[Szulinski] - Szulinski, J. et al, (2005), “Bandwidth Reduction Techniques Used in DIS Exercises: An Update”, Proceedings of the 2005 Fall Simulation Interoperability Workshop, Orlando, FL, USA, September 2005, 05F-SIW-105.

[TENA] - The Test and Training Enabling Architecture – Architecture Reference Document (2002), <http://www.tena-sda.org/>

[Tudor] - Tudor, G. and Zalzman, L., (2006) “HLA Interoperability – An Update”, Proceedings of the SimTecT2006 Conference, Melbourne.

[UK] – UK Ministry of Defence, (2005) “Synthetic Environment and Modelling and Simulation (SEMS) Glossary”, <http://192.5.30.131/issues/simulation/glossary.htm>

[US] - U.S. Department of Defense (1995) “Modeling and Simulation (M&S) Master Plan (DoD Publication number 5000.59-P)

[Wikipedia] – www.wikipedia.com

[Wood] - Wood, C., Lopez, P., Garcia, H. and Van Geest, J., (2008), “Develop a Federation to Demonstrate the NATO Live, Virtual and Constructive Concept”, Proceedings of the 2008 European Simulation Interoperability Workshop, Edinburgh, Scotland, June 2008, 08E-SIW-038.

[Zalzman (2003)] - Zalzman, L., Ryan, P., Clark, P. and Britton, M. (2003) “JOANNE Standards for Training Simulator Interoperability”, DSTO Technical Report DSTO-TR-1462, July 2003.

[Zalzman (2004) - 1] - Zalzman, L. (2004) “What DIS PDUs Should Be In My ADF Training Simulator?”, Proceedings of the SimTecT2004 Conference, Canberra, May 2004.

[Zalzman (2004) - 2] - Zalzman, L. (2004) “What DIS PDUs Should My ADF Simulator Have?”, DSTO Technical Report DSTO-TR-1565, March 2004.

[Zalcman (2005)] - Zalcman, L., (2005) "The Royal Australian Air Force, Air Defence Ground Environment Simulator", Proceedings of the I/ITSEC 2005 Conference, Orlando, Florida, USA, November 2005.

[Zalcman (2006)] - Zalcman, L., Blacklock, J., Filippidis, A. and Lawrie, G., (2006), "The DSTO Net Warrior Exercises – The ADGESIM Contribution", Proceedings of the SimTecT2006 Conference, Melbourne, Australia, May, 2006.

[Zalcman (2007)] - Zalcman, L. and Blacklock, J., (2007) "A Standard Australian DIS Entity Set", In Draft.

[Zalcman (2007) - 2] - Zalcman, L., Filippidis, A., Gencarelli, M., Lawrie, G., Blacklock, J., and Henschke, S. (2007), "Integrating the ADF AEW&C Operational Mission Simulator into the DSTO Net Warrior Architecture", Proceedings of the Twelfth Australian International Aerospace Congress Conference, Melbourne, Australia, March, 2007.

[Zalcman (2008)] - Zalcman, L., Filippidis, A. and Gencarelli, M., "LVC Interoperability and Synthetic Range Concept Research in the DSTO Net Warrior Project – A SimTecT2008 Update", Proceedings of the SimTecT2008 Conference, Melbourne, Australia, June 2008.

[Zalcman (2010) - 1] - Zalcman, L., Ross, P., and Blacklock, J. (2010) "A Link-16 Development Capability for DSTO's Air Operations Division at Fishermans Bend", DSTO Technical Report DSTO-TR-2477, October 2010.

[Zalcman (2010) - 2] - Zalcman, L., Ross, P., and Blacklock, J. (2010), "Link-16 Interoperability for Air Combat Officer Training at RAAF Williamtown and RAAF Sale Using the ADGESIM and AWSIM Trainers", SimTecT2010 Conference, Brisbane, Australia, June 2010.

DEFENCE SCIENCE AND TECHNOLOGY ORGANISATION DOCUMENT CONTROL DATA					1. PRIVACY MARKING/CAVEAT (OF DOCUMENT)	
2. TITLE USAF Distributed Mission Operations, an ADF Synthetic Range Interoperability Model and an AOD Mission Training Centre Capability Concept Demonstrator - What Are They and Why Does the RAAF Need Them?			3. SECURITY CLASSIFICATION (FOR UNCLASSIFIED REPORTS THAT ARE LIMITED RELEASE USE (L) NEXT TO DOCUMENT CLASSIFICATION) Document (U) Title (U) Abstract (U)			
4. AUTHOR(S) Lucien Zalcmán and Jon Blacklock			5. CORPORATE AUTHOR DSTO Defence Science and Technology Organisation 506 Lorimer St Fishermans Bend Victoria 3207 Australia			
6a. DSTO NUMBER DSTO-TR-2463		6b. AR NUMBER AR-014-839		6c. TYPE OF REPORT Technical Report		7. DOCUMENT DATE October 2010
8. FILE NUMBER 2010/1066355	9. TASK NUMBER AIR 07/232	10. TASK SPONSOR DGCP-AF		11. NO. OF PAGES 91		12. NO. OF REFERENCES 85
13. URL on the World Wide Web http://www.dsto.defence.gov.au/corporate/reports/DSTO-TR-2463.pdf			14. RELEASE AUTHORITY Chief, Air Operations Division			
15. SECONDARY RELEASE STATEMENT OF THIS DOCUMENT <i>Approved for public release</i> OVERSEAS ENQUIRIES OUTSIDE STATED LIMITATIONS SHOULD BE REFERRED THROUGH DOCUMENT EXCHANGE, PO BOX 1500, EDINBURGH, SA 5111						
16. DELIBERATE ANNOUNCEMENT No Limitations						
17. CITATION IN OTHER DOCUMENTS Yes						
18. DSTO RESEARCH LIBRARY THESAURUS http://web-vic.dsto.defence.gov.au/workareas/library/resources/dsto_thesaurus.shtml US Air Force Distributed Mission Operations, Coalition LVC Training, LVC Interoperability, Mission Training Centre						
19. ABSTRACT Today simulation technology allows warfighters to participate in a continuous training cycle and maintain a high state of combat readiness by using cost-effective simulation alternatives in conjunction with live-fly operations and training missions. Current development of Live, Virtual, and Constructive (LVC) systems for training and mission rehearsal, the rapid advancement of networking technologies and protocol standards/architectures such as Distributed Interactive Simulation (DIS) and High Level Architecture (HLA) have all contributed to an environment where highly-distributed training, mission rehearsal, operations support, and multi-force Distributed Mission Operations (DMO) joint/coalition exercises have become a reality. The objective of this report is to offer guidance on how to progress towards such a highly interoperable, LVC synthetic environment. Corporate LVC interoperability standards, processes, common applications and databases need to be developed so that LVC systems can be appropriately specified, delivered and accepted with an already useable level of corporate interoperability that will enable coalition LVC training "out-of-the-box". An AOD, Air Battle Management, Mission Training Centre (MTC) Capability Concept Demonstrator, that will provide guidance to assist the RAAF to migrate to a highly interoperable, DMO compliant, LVC synthetic environment (including a coalition training focussed, RAAF MTC), has been proposed.						