

COMBAT RATION NETWORK
FOR
TECHNOLOGY IMPLEMENTATION
(CORANET II)

Knurled Seal Heat Bar

Final Technical Report STP 2024

Results and Accomplishments (Date Nov 2006 – July 2010)

Report No: FTR 220

CDRL Sequence: A003

August 2010

CORANET CONTRACT NO. SP0103-02-D-0024

Sponsored by:
DEFENSE LOGISTICS AGENCY
8725 John J. Kingman Rd.
Fort Belvoir, VA 22060-6221

Contractor:
Rutgers, The State University of New Jersey
THE CENTER FOR ADVANCED FOOD TECHNOLOGY*
School of Environmental and Biological Sciences
N.J. Agricultural Experiment Station
New Brunswick, New Jersey 08903

Principal Investigator:
Jeffrey S. Canavan
Co-Principal Investigator:
H.B. Bruins

TEL: 732-445-6130
FAX: 732-445-6145

REPORT DOCUMENTATION PAGE

*Form Approved
OMB No. 0704-0188*

The public reporting burden for this collection of information is estimated to average 1 hour per response, including the time for reviewing instructions, searching existing data sources, gathering and maintaining the data needed, and completing and reviewing the collection of information. Send comments regarding this burden estimate or any other aspect of this collection of information, including suggestions for reducing the burden, to Department of Defense, Washington Headquarters Services, Directorate for Information Operations and Reports (0704-0188), 1215 Jefferson Davis Highway, Suite 1204, Arlington, VA 22202-4302. Respondents should be aware that notwithstanding any other provision of law, no person shall be subject to any penalty for failing to comply with a collection of information if it does not display a currently valid OMB control number.

PLEASE DO NOT RETURN YOUR FORM TO THE ABOVE ADDRESS.

1. REPORT DATE (DD-MM-YYYY) August 2010		2. REPORT TYPE Final		3. DATES COVERED (From - To) November 2006 – July 2010	
4. TITLE AND SUBTITLE Knurled Seal Heat Bar				5a. CONTRACT NUMBER SP0103-02-D-0024 / 0014	
				5b. GRANT NUMBER	
				5c. PROGRAM ELEMENT NUMBER	
6. AUTHOR(S) Mr Jeffrey Canavan Mr. Henderikus B. Bruins				5d. PROJECT NUMBER STP # 2024	
				5e. TASK NUMBER	
				5f. WORK UNIT NUMBER A003	
7. PERFORMING ORGANIZATION NAME(S) AND ADDRESS(ES) Rutgers, The State University of New Jersey The Center for Advanced Food Technology School of Enviromental and Biological Sciences New Brunswick, NJ 08903				8. PERFORMING ORGANIZATION REPORT NUMBER FTR 220	
9. SPONSORING/MONITORING AGENCY NAME(S) AND ADDRESS(ES) Defense Logistics Agency 8725 John J. Kingsman Rd Fort Belvoir, VA 22060-6221				10. SPONSOR/MONITOR'S ACRONYM(S)	
				11. SPONSOR/MONITOR'S REPORT NUMBER(S)	
12. DISTRIBUTION/AVAILABILITY STATEMENT Approved for public release; distribution is unlimited.					
13. SUPPLEMENTARY NOTES					
14. ABSTRACT The objective of this CORANET Short Term Project was to quantify the effects of applying a pattern to the sealing bars of pouch sealing machines. Previous research had shown that patterned or knurled seal bars improved seal integrity of pouches that had contaminated seals. This STP documents patterns, seal condition changes, and results for various patterns and contaminate combinations. Significant improvement in peel strength was observed compared to traditional flat sealing bars. Recommendations and data are documented based on a benchtop sealer. Interactions of sealing conditions when applied to foil laminate films used for MRE pouch production were also documented. Technology transfer was started in phase II of this project during which a commercial Horizontal Form Fill Seal MRE pouch line was retrofitted with knurled seal plates. A cost benefit analysis will be completed to quantify financial benefits once Performance Monitoring is completed under the follow-on STP.					
15. SUBJECT TERMS Rations, Foil laminate, pouches, MRE, individual, Ultrasonic Sealing, knurled seal, CORANET, Rutgers, Implementation, Transition, Contamination, protocol development, seal integrity, entrapped matter, seal strength, peel test, destructive test, vertical, HFFS, STP					
16. SECURITY CLASSIFICATION OF:			17. LIMITATION OF ABSTRACT Unclassified	18. NUMBER OF PAGES	19a. NAME OF RESPONSIBLE PERSON Jeffrey Canavan
a. REPORT Unclassified	b. ABSTRACT Unclassified	c. THIS PAGE Unclassified			19b. TELEPHONE NUMBER (Include area code) 732-445-6130

INDEX

1. Results and Accomplishments.....	4
1.1. Introduction and Background	4
1.2. Objectives	4
1.3. Results and Conclusions.....	4
1.4. Recommendations	5
2. Short Term Project Activities	6
2.1. Phase I: “Bench top Evaluation”	6
2.1.1. Literature Search.....	6
2.1.2. Test Protocols and Methods.....	6
2.1.3. Sealing Studies MRE pouches.....	6
2.1.4. Data Analysis.....	7
2.2. Phase II: “Production Scale Evaluation”	7
2.2.1. Designing Knurled Seal Bars.....	7
2.2.2. Implementation and Performance Monitoring.....	7
2.2.3. Updating Cost Benefit Analysis	7
3. Program Management	8
4. Appendix	9

1. Results and Accomplishments

1.1. Introduction and Background

Knurled seal bars improved the effectiveness of ultrasonic sealing systems. The ration industry was interested in evaluating the incremental effects of the knurled seal bar in an existing heat bar sealing system. Implementation of a knurled seal bar in an existing packaging line represents a low cost, low risk and easy to implement and maintain improvement. The key objective of this project was to evaluate the effectiveness of the knurled seal bar in a heat seal system under various degrees of seal contamination. Initial trials were done on a bench-top heat seal system under controlled conditions to determine the interactions between knurled seal pattern, sealing conditions and contamination. These trials were then used to conduct plant trials on commercial sized MRE packaging equipment. Phase I and parts of Phase II of this project were completed and successful. However, the final part of Phase II, Performance Monitoring, has not been completed. A new follow-on project has been proposed to continue Performance Monitoring under the current CORANET contract. Additionally, some concern was raised regarding the effect the pattern would have on inspection. The follow-on project will include the development of a destructive test protocol to evaluate suspect pouches.

If the follow-on project for Performance Monitoring and Destructive Testing is approved and successful, improvement in sealing and cost avoidance would be realized.

The CORANET Program pursued two short term projects in the area of Ultrasonic Sealing. Project 1013 – Feasibility Study Ultrasonic Sealing of MRE pouches – was a bench top comparison of ultrasonic sealing technology that included the participation of five ultrasonic sealing equipment manufacturers. Project 2004 – Ultrasonic Sealing in MRE Pouch Production – scaled up the process by retrofitting a Bartelt single lane preformed pouch packaging machine with Dukane ultrasonic sealing equipment. The results of these studies confirmed the capability of the ultrasonic sealing process to seal through contamination. This improvement in seal performance was obtained by using a knurled seal bar in conjunction with ultrasonic energy. Initial trials that used a flat seal bar in conjunction with ultrasonic energy did not yield improvements in seal strength. Based on these studies allowances were made in the packaging specification for the use of a knurled seal bar.

Although the results from Project 2004 were positive, a number of issues were identified that remain to be addressed before the technology can be successfully transitioned. Also the implementation of Ultrasonic sealing technology and retrofitting existing systems is for most companies cost prohibitive.

Because the project demonstrated the positive effects of a knurled seal bar in the final closure seal, the obvious question asked was if the knurled seal bar would also have a positive impact in a conventional heat seal system. Such benefit was demonstrated.

1.2. Objectives

The objective of this project is to quantify the effects of a knurled seal bar on the seal integrity of pouches that had contaminated seals. Recommendations for knurled patterns and the interactions with sealing conditions were documented. Technology transfer was started in the second phase of this project during which a commercial MRE pouch line was configured with knurled seal bars. As the final task, the cost benefit analysis will be updated to quantify financial benefits once Performance Monitoring is completed under the follow-on STP.

1.3. Results and Conclusions

The initial project proposal included retrofitting MRE vertical seal lines with knurled heat sealing plates. As the effectiveness of Ultrasonic Sealing become apparent, the decision was made to

apply knurling to MRE Horizontal Form Fill Sealing (HFFS) instead. Vertical filling machines could be cost-effectively retrofitted with Ultrasonic. HFFS lines cannot be retrofitted to Ultrasonic Sealing easily.

A stand-alone bench top sealer was purchased from Wrapade for this project and heat bars were machined with commercially available knurl patterns. From the sample patterns, the best performer was selected for implementation on a Multivac Pouch Horizontal Form Fill and Seal (HFFS) machine. The original knurl pattern schematic provided by Wrapade was released for limited distribution. The schematic contained an error in the knurl height. Multivac altered dimensions of the rest of the pattern to fit the erroneous height resulting in a pattern that was 2x too large. Ameriqua was unable to produce pouches with the altered pattern. The seal plate caused perforations at the seal area. Analysis of pouches revealed the issues and the plates were shipped back to Multivac for warranty re-machining.

Production had the HFFS booked through late July, 2009. After installation and fine-tuning of the revised plates, a challenge study was conducted in the plant following the same protocols defined for Ultrasonic Seal validation on September 15, 2009. Contaminates were introduced into the seal area, pouches retorted, and seals analyzed.

Pouches integrity was not up to the level of produced by ultrasonic or by the one-up sealer during Phase I. It was determined that the bottom seal rubbers were flat, not rounded as demonstrated successfully in Phase I. Multivac supplied a quotation to duplicate the rounded profile of the rubbers shown to be effective. Approval for purchase of the rubbers was delayed until January 2010 causing the entire project to slip. The sealing rubbers were shipped and installed in early March. A challenge study was scheduled for April 29-May 1, 2010. Machine settings were not optimized before testing. The resulting pouch strengths were improved from flat bars, but not as strong as demonstrated during the one-up testing. Further fine-tuning would improve system performance significantly. Production was not scheduled in time to allow for 3 months of production data. CORANET II projects are being phased out. Further work to complete this project will continue under a new STP under CORANET III if approved.

Test runs conducted at the partner plant site run showed improvement in sealing through various types and levels of intentional contamination over conventional flat plates. Some additional improvement would be realized with additional machine fine-tuning as there was some variability in seal strength in specific locations along each pouch position.

1.4. Recommendations

All HFFS MRE sealing machines should be retrofitted with knurled sealing plates once the technology is demonstrated in the production environment. The demonstrated seal quality provided by knurled plates versus conventional flat plates has been demonstrated repeatability on a benchtop unit. Until all pouches can be sealed with Ultrasonic Sealing, knurling represents a significant improvement to the existing technology with minimal cost. Successful installation relies on sealing consistency. Uniform seal strength should be obtained to maximize system performance.

The pattern that was ultimately used for Phase II was;

45° 20TPI Pointed Squares (Common Knurl).

One important correction to the drawing, the 10x detail that reads 0.233" should be 0.0117". Distribution of the document was approved by the designer, Wrapade Packaging. The CAD drawing can be found in appendix 4.11.

Increasing sealing temperature and pressure increased seal strength in bench top testing. Sensitivity analysis should be conducted on specific machinery to maximize system performance.

Risk associated with pouch acceptance, lot rejection, and suspect pouches can be reduced by the continuation and conclusion of the Performance Monitoring and MRE Destructive Pouch Protocols proposed as a follow-on project to implementation. Successful application of this

demonstrated technology will rely on industry and government cooperation since changes to inspection protocols will be required.

2. Short Term Project Activities

2.1. Phase I: “Bench top Evaluation”

2.1.1. Literature Search

Past CORANET project final reports were obtained and reviewed. Available literature from Ultrasonic Sealing technology producers was collected and reviewed. A Literature search was completed on Knurled Seal Bars.

The STP Kickoff meeting slides can be found in appendix 4.1.

2.1.2. Test Protocols and Methods

Protocols were developed to sealing technology based on worse case heat seal criteria. Contaminates, methodologies, sampling plans, and testing methods were developed with input from the CORANET group, producers, and the JSG liaison. Real products from the broad categories were used as available to maintain consistency between different producers, lots, and production lines. Details of the protocol can be found in Appendix 4.3. After discussion and review, a consensus on a testing protocol was reached. Pouches were sealed with varying contaminants, levels of contamination, temperatures, times, and sealing pressures.

The following tests were to used to measure package integrity:

- Internal pressure test, 20 psi for 30 seconds as defined by specification (Pass/Fail)
- Peel strength, maximum force for 1” sample cut from knurled seal (lbs.)
- Internal pressure test, increasing pressure until package failure (psi)

2.1.3. Sealing Studies MRE pouches

Water filled pouches were sealed following the test protocol. Pouches were retorted and stored for a minimum of 48 hours. Each pouch was tested in the internal pressure test. After passing, the closure seals were analyzed for peel strength by cutting three 1” strips out of the seal and measuring the maximum seal force required to separate seals.

Data from the studies was outlined in the Phase I IPR meeting slides and can be found in appendix 4.4.

Sealing Studies of MRE Pouches – Knurled bars & Contaminates

- Sealing Variables
 - » Time (0.5, 1.0, 1.5 seconds)
 - » Temperature (Optimal, +10F, +20F)
 - » Pressure (25psi, 35psi, 45psi)
- Contamination Level (Light spray & Gross)
- Contaminates (Water, Beef Gravy, Buttered Starch, Sugar syrup)
- 18 seal configurations (1-5 knurled and flat bars, 1 rounded & 1 knurled backer plate)

As the pouch seal might weaken due to storage conditions, a number of pouches with and without contaminated seals were placed in storage and evaluated after 6 month for seal strength. No significant changes were noted.

2.1.4. Data Analysis

Data collected in the previous task was analyzed for significant interactions of seal conditions, knurled seal pattern, seal contaminant and seal strength. The best configuration of tested knurled patterns and seal conditions was determined and reported.

The Phase I IPR meeting slides contain data from the testing and can be found in appendix 4.4.

2.2. Phase II: “Production Scale Evaluation”

2.2.1. Designing Knurled Seal Bars

In cooperation with one of our Industry Partners, Ameriqua Foods, sealing equipment was selected for knurled seal bar installation. Multivac was contracted to machine a set of knurled plates following the pattern shown to be best at sealing through contamination.

2.2.2. Implementation and Performance Monitoring

Prior to replacing the seal bars, data was collected on rejects rates of seals with entrapped matter, during the before or after retort visual inspection phase. This data is proprietary in nature and will not be reported directly. When data from knurled production is made available, both data sets will be compared and the improvements reported.

This project task has not been completed due to time constraints and the need to end CORANET II STPs. A follow-on STP phase 0 was submitted for continuing this project task. Results from plant testing were positive. When contamination was present with the original flat sealing system, 100% of pouches had open seals. Machine settings were not optimized before testing. The resulting pouch strengths were improved from flat bars, but not as strong as demonstrated during the one-up testing. Further fine-tuning would improve system performance significantly.

Knurled seal bars will be re-installed and sealing conditions will be fine tuned. Initially, frequent samples will be pulled off line for a seal strength test to assure that no product is produced that does not meet the military requirements. After the initial validation step, product will be produced using the same procedures as when used during the “flat bar” sealing process. Data will be collected on rejects rates of seals with entrapped matter, during the before or after retort visual inspection phase.

As a secondary implementation step, we might reduce the labor requirements for cleaning seals to study the effect of this on the overall reject rate. Again, data will be collected on rejects rates of seals with entrapped matter, during the before or after retort visual inspection phase.

2.2.3. Updating Cost Benefit Analysis

Based on the cost of the knurled seal bar and the reject rates documented in the above test, we will update the cost benefit analysis of this project. Since these tasks were not completed, the cost benefit analysis could not be completed without the data from the uncompleted tasks.

3. Program Management

The project was awarded on November 7, 2006 under contract SP0103-02-D-0024, delivery order 0014 with an initial obligation of \$99,689. Performance period for this delivery order was originally set for 11/07/07.

The following modifications were issued:

Date	Modification	Description
11/07/07	0014/01	Performance period extended from 11/07/07 to 07/30/08.
07/28/08	0014/02	Performance period extended from 07/30/08 to 12/31/08. Increase of obligation from \$99,689.00 to \$135,934.00.
12/24/08	0014/03	Performance period extended from 12/31/08 to 06/30/09.
06/25/09	0014/04	Performance period extended from 06/30/09 to 12/31/09.
12/30/09	0014/05	Performance period extended from 12/31/09 to 04/30/10.
01/04/10	0014/06	Increase of obligation from \$135,934.00 to \$179,931.00.
01/04/10	0014/07	All other term remain unchanged.
04/29/10	0014/08	Performance period extended from 04/30/10 to 05/06/10.
05/06/10	0014/09	Performance period extended from 05/06/10 to 07/06/10.

4. Appendix

4.1. STP Kickoff, December 2006

4.2. Workshop 18, March 2007

4.3. Workshop 19, June 2007

4.4. Phase I, IPR, October 2007

4.5. Workshop 20, November 2007

4.6. Workshop 21, April 2008

4.7. Workshop 22, July 2008

4.8. Workshop 1, December 2008

4.9. Workshop 4, October 2009

4.10. Workshop 5, March 2010

4.11. Knurl Pattern Schematic

Appendix 4.1

STP Kickoff, December 2006

STP#2024 Knurled Heat Seal Bar
Kick Off Meeting
CORANET Demo Site

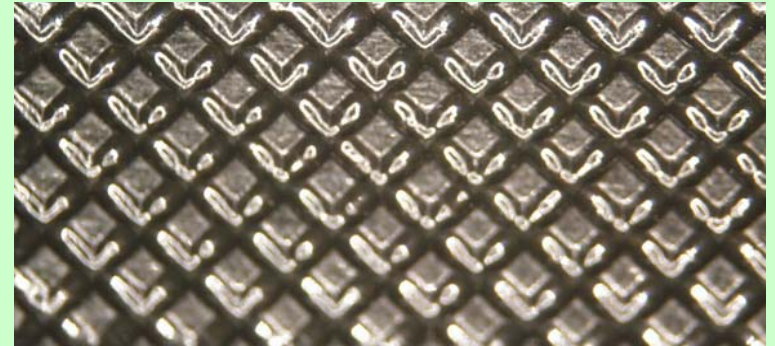
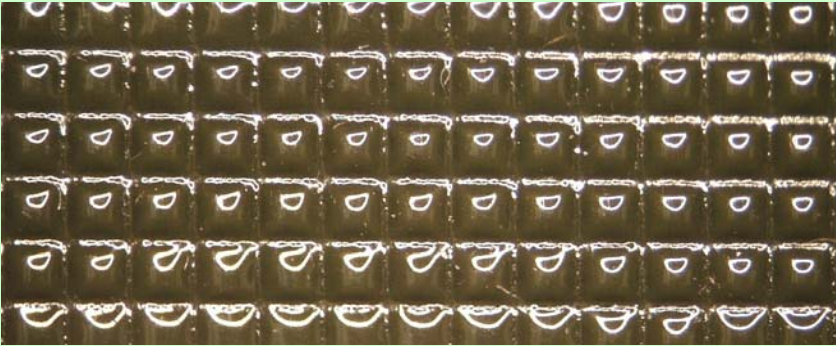

December 13, 2006

PIs: Jeff Canavan

Rieks Bruins

STP#2024 Presentation Overview

- Objectives
- Scope of Work
- Literature Review
- Testing Protocol Discussion
- Experiment Details
- Materials Needed
- Phase II: Implementation Outline

STP #2024 Objectives

- Quantify effect of knurled seal bar on strength of contaminated seals
- Document interactions with sealing conditions
- Transfer Technology to industry
- Update Cost / Benefit analysis

STP#2024 Scope of Work

- Literature Search (Complete)
- Testing Protocols and Methods
- Sealing Studies MRE Pouches
- Data Analysis of Pouch Seal Strength
- Recommend Knurled Seal Bar Design
- Implementation and Performance Monitoring
- Updating Cost Benefit Analysis

Literature Search Results

- No published findings on knurled or patterned seal bars effect on seal strength in engineering, trade, or packaging journals
- On-line web search yielded no useful research results
- Contact with machine manufactures produced anecdotal evidence of improved seal characteristics without documentation or research results
- One manufacturer suggested rounded seal bars or seal rubbers for improved sealing through viscous contaminates
- Seal manufacturer reported seal strength information and bar design details are not shared by companies

Test Protocol

Pattern Selection Discussion

- Common knurl types

1. Straight tooth, 0° to edges

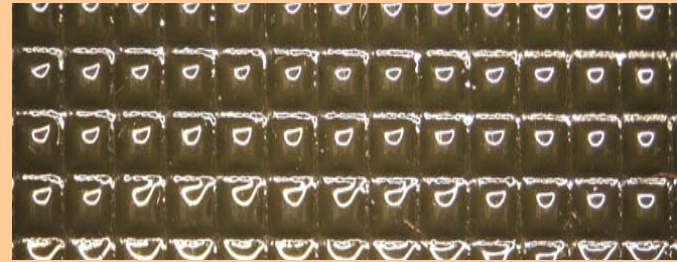

2. Straight tooth, 45° to edges



3. Diamond tooth, 0° to edges (Sample sealer)

4. Diamond tooth, 45° to edges

5. 30° Diagonal diamond, Male (See fitting)

6. 30° Diagonal diamond, Female

Matching Combinations

- Test configurations for paired heat bars
 - Baseline - pair of non-patterned bars
 - Selected patterns Course 20 TPI and Fine 40 TPI
 - Paired bars
 - Paired with non-patterned bar
 - Interest in Multi-pass sealing? Cooling Bar patterns?
 - Lab sealer selection
 - Functional requirements
- Test configurations for heat bar & backing plate
 - Selected knurl patterns, plus a flat bar paired with;
 - Flat, non-patterned backing rubber
 - Rounded, non-patterned backing rubber
 - Flat, fine(40tpi) patterned backing rubber
 - Rounded, fine patterned backing rubber
 - Flat, course(20tpi) patterned backing rubber
 - Rounded, course patterned backing rubber



Sealing Studies and Data Analysis of MRE Pouches

- Pouches will be filled with water.
- Contaminates to be smeared in seal area in two quantities, light or heavy
 - Proposed Contaminates
 - Water
 - Beef Gravy
 - Buttered Noodles
 - Fruit syrup
- Pouches will be labeled, sealed, and retorted
- After 48+ hours, Internal Pressure tests
- Passing seals tested using an Instron
- A sample set stored at ambient and 100 F to be evaluated after 6 month for seal strength.
- 12 month retention samples could be studied if 6 month samples show weakening

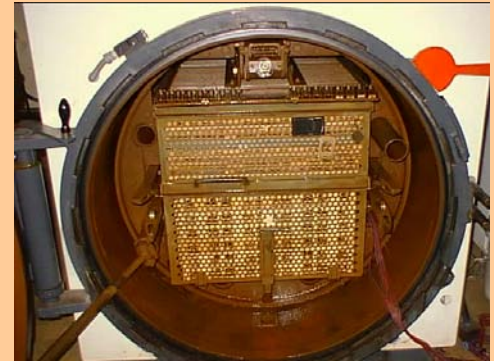

Input from Virginia Tech



- Curved seal bars cause sealant to move during sealing
 - Improves seal quality
 - Asymmetric seal strength, best for peelable seals
- Good sealant movement = Good bond
- Virginia Tech has video caliper equipment
 - Could provide pouch measurements for this project
 - Seal structure of different patterns could be quantified

Materials Needed

- 5000 Pre-formed pouches
- Beef gravy from stew
- Buttered Noodles
- Fruit syrup

STP#2024 Scope of Work - Phase II

- Recommend Knurled Seal Bar Design
 - In cooperation with Industry Partners, sealing equipment will be selected for new knurled seal bars. Bars will be designed and manufactured.

STP#2024 Scope of Work - Phase II

- Implementation and Performance Monitoring
 - Rejection rate due to entrapped matter will be determined in before/after retort inspection phases.
 - After adequate data is collected, knurled seal bars will be installed and sealing conditions fine tuned as if necessary.
 - Initially, frequent samples will be pulled off line for a seal strength tests to assure that no product is produced that does not meet the military requirements.
 - After the initial validation step, product will be produced using the same procedures as the “flat bar” sealing process.
 - Data will be collected on rejects rates of seals with entrapped matter, during before or after retort visual inspection phases.
 - As a secondary implementation step, labor for cleaning seals may be reduced. The effect of this on the overall reject rate will be studied. Data will be collected on rejects rates of seals with entrapped matter, during before/after retort visual inspection phase.

STP#2024 Scope of Work - Phase II

- Updating Cost Benefit Analysis
 - Based on the cost of the knurled seal bar and the reject rates documented in the above test, we will update the cost benefit analysis of this project.

Next Steps



- Acquire pouches and contaminates
- Select and order laboratory sealer based on feedback from this meeting
- Design experiments to maximize variable correlation using a minimum of test samples

Appendix 4.2

Workshop 18, March 2007

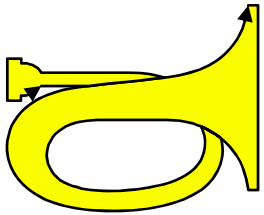

COMBAT RATION NETWORK FOR TECHNOLOGY IMPLEMENTATION (CORANET)

Effectiveness of a Knurled Heat Seal Bar, STP2024



**Benchtop Heat Sealer,
Wrap-Ade® Model K**

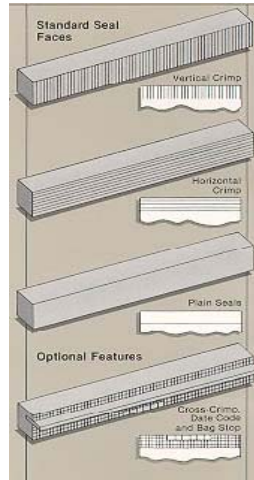

OBJECTIVE

Evaluate the effect of knurled seal bar patterns on sealing strength through contaminants.
Recommend bar pattern and transfer technology to production
Document cost / benefit of implementation

BENEFITS

- Potential for improved seal strength when contamination present, more robust sealing systems
- Low cost and quick implementation
- Reduction in lot rejections due to leakers/weak seals

BUSINESS STRATEGY

- Annual Ration Production: Tray Pack and MRE Production
- Developing Partners: Ameriquel, Sopakco, Wornick, Rutgers, Wrapade Packaging Systems
- Demonstration Site: Rutgers FMT Facility
- Production Site: TBD
- Project Duration: 12 months

Related Efforts

- CORANET STP1013 – Feasibility Study Ultrasonic Sealing of MRE pouches
- STP2004 Ultrasonic Sealing MRE Production

IMPLEMENTATION

- Phase I: Bench Top Evaluation
- Phase II: Production Scale Evaluation

Knurled Heat Seal Bars – Recent Activities

- Kick off meeting held on December 13.
 - Literature Search Results Reviewed
 - 5 of 12 patterns were selected for the project
 - » Straight tooth 45° fine and course (flat squares)
 - » Diamond tooth 45° fine (pointed squares)
 - » Diamond 30° female fine and course (inverted diamonds)
 - Flat bars, rounded and patterned backing rubbers are to be included
 - Multi-pass sealing was not seen as valuable and was excluded
- Test Protocols and Methods
 - 5 Quotes received and test seal samples evaluated
 - Unit Selected - Wrap-Ade[®] Benchtop Sealer Model K - 12”
 - » Constant independent heat control, top and bottom, configurable to simulate HFFS (single) and Vertical fill (dual)
 - » Factory is local, has knurling experience, and units ready to ship
 - » Design allows for low cost change out of bars and/or seal rubber

Knurled Heat Seal Bars – Project Plans

- Test Protocols and Methods
 - Order heat sealer and knurled bars
 - Obtain project materials
 - » 5000 Pre-formed pouches
 - » Beef gravy from stew
 - » Buttered Noodles
 - » Fruit syrup
 - Design experiments to maximize variable correlation using a minimum of test samples
- Sealing Studies of MRE Pouches (March-June)
- Complete Data Analysis (May-June)
- Schedule IPR

Appendix 4.3

Workshop 19, June 2007

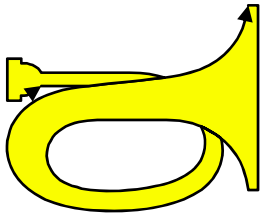

COMBAT RATION NETWORK FOR TECHNOLOGY IMPLEMENTATION (CORANET)

Effectiveness of a Knurled Heat Seal Bar, STP2024



**Benchtop Heat Sealer,
Wrap-Ade® Model K**

OBJECTIVE

Evaluate the effect of knurled seal bar patterns on sealing strength through contaminants.
Recommend bar pattern and transfer technology to production
Document cost / benefit of implementation

BENEFITS

- Potential for improved seal strength when contamination present, more robust sealing systems
- Low cost and quick implementation
- Reduction in lot rejections due to leakers/weak seals

BUSINESS STRATEGY

- Annual Ration Production: Tray Pack and MRE Production
- Developing Partners: Ameriquel, Sopakco, Wornick, Rutgers, Wrapade Packaging Systems
- Demonstration Site: Rutgers FMT Facility
- Production Site: TBD
- Project Duration: 12 months

Related Efforts

- CORANET STP1013 – Feasibility Study Ultrasonic Sealing of MRE pouches
- STP2004 Ultrasonic Sealing MRE Production

IMPLEMENTATION

- Phase I: Bench Top Evaluation
- Phase II: Production Scale Evaluation

Knurled Heat Seal Bars – Recent Activities

- April meetings with Wrap-Ade Engineers to review knurl pattern geometries and machining processes
- 5 Final design revisions were approved for manufacturing on May 7th.
 - » Flat squares at 45° 20tpi & 30tpi
 - » Pointed Diamond teeth 120° 30tpi (Interlocking)
 - » Pointed Squares at 45° 20tpi & 30tpi (Interlocking)
- Specialty tooling on order to machine approved patterns
- Tooling delays and machining backlog has pushed back delivery of the knurled plate sets to late June.
- Wrap-Ade unit acceptance testing with flat bars was completed in Fairfield NJ on May 16.
- Baseline control sample testing has begun using stock flat bars
- Pouches and test contaminates were requested from partners
 - Request material and re-imbusement follow-up

Knurled Heat Seal Bars – Project Plans

- Test Protocols and Methods
 - Follow up with partners to obtain pouches and revisit test materials
- Continue Sealing Studies of MRE Pouches – Knurled bars & Contaminates
 - Sealing Variables
 - » Time (0.5, 1.0, 1.5 seconds)
 - » Temperature (Optimal, +10F, +20F)
 - » Pressure (25psi, 35psi, 45psi)
 - Contamination Level (Light spray & Gross)
 - Contaminates (Water, Beef Gravy, Buttered Starch, Sugar syrup)
 - 18 seal bar configurations (1-5 knurled and flat bars pairs, 1 rounded & 1 knurled backer plate)
- Complete Data Analysis
- Schedule IPR

Appendix 4.4

Phase I, IPR, October 2007

STP#2024 Knurled Heat Seal Bar



Phase 1 IPR Meeting
CORANET Demo Site

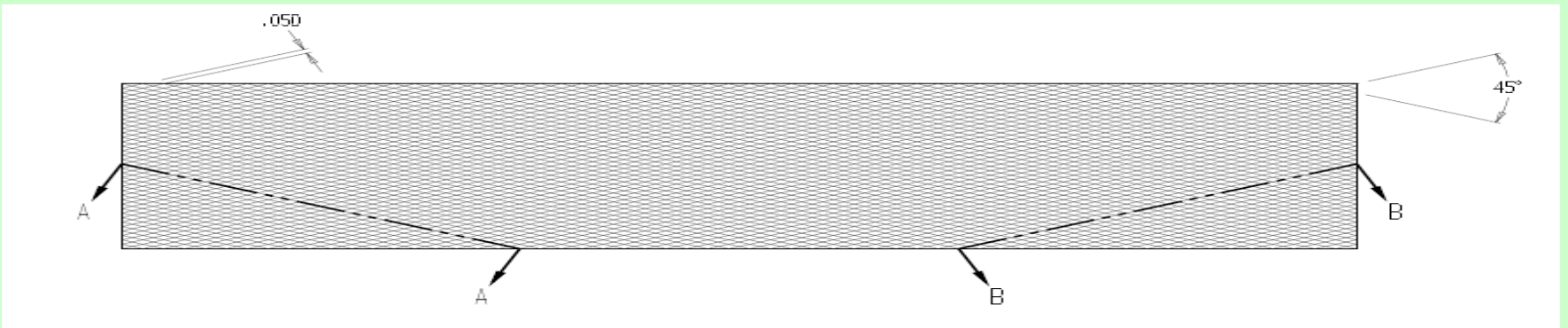
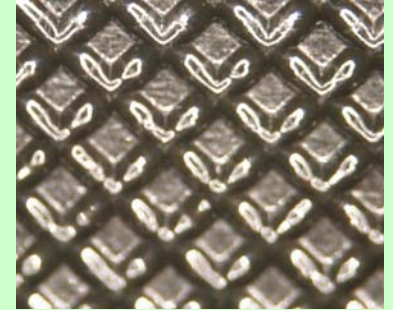

October 11, 2007
PIs: Jeff Canavan
Rieks Bruins

STP#2024 Presentation Overview

- Objectives
- Scope of Work
- Literature Review
- Testing Protocol Description
- Interim Experimental Results
- Expanded Test Groupings
- Phase II: Implementation Discussion

STP #2024 Objectives

- Quantify seal characteristics of knurled seal bars on strength of contaminated seals
- Document interactions with sealing conditions
- Support Technology Transfer to industry if proven beneficial
- Update Cost / Benefit analysis

STP#2024 Scope of Work

- Literature Search (Complete)
- Testing Protocols & Methods (Complete)
 - Sealer and pattern selection
 - Protocol development
- Sealing Study MRE Pouches
 - Test bars with fixed sealing conditions / variable contamination and analyze data (Complete)
 - Conduct sealing condition sensitivity analysis on two primary candidate bars
- Recommend Knurled Seal Bar Design
- Implementation and Performance Monitoring Support
- Updating Cost Benefit Analysis

Literature Search Results

- As previously reported, no published findings on knurled seal bars were found in engineering, trade, or packaging journals
- Natick Technical Report 69-76-GP concluded that a curved-bar sealing system could significantly improve seal reliability
 - Based on this report, the HFFS configuration tested included the use of a rounded rubber backer instead of flat textured rubber sheets as previously outlined
- Contact with machine manufactures produced anecdotal evidence of improved seal characteristics without documentation or research results
- One manufacturer suggested rounded seal bars or seal rubbers for improved sealing through viscous contaminates (HFFS)
- Seal manufacturer reported seal strength information and bar design details are not shared by companies

Sealing Studies Test Procedure

- Pre-formed Pouches sourced from Ameriquel were filled with water.
- A uniform continuous layer of contaminate was smeared on the seal area of one or two sides of the seal area with a brush.
 - Contaminates
 - Water
 - Beef Stew (MRE)
 - Fruit Cocktail (MRE)
 - Rice, Mexican (MRE)
- Pouches were sealed, labeled, and retorted.
- Plain bar sensitivity analysis yielded test conditions
 - 2 bar (Vertical Fill); 325°F for 0.9sec @ 45psi.
 - 1 bar w/backer (HFFS); 440°F for 1.2sec @ 25psi.
- After 48+ hours, IP tests, 20psi for 30 seconds
- Passing pouches had 3, 1" strips peel tested
- A duplicate group of retention samples were made
- Additional testing could be done immediately or after an interval



IP Test Results

325°F - Vertical Fill										
Pattern/Cont.	Clean	Water1	Water2	Stew1	Stew2	Fruit1	Fruit2	Rice1	Rice2	Total
Plain	0/3	1/5	0/5	1/5	2/5	0/5	0/5	0/5	0/5	4/40
A	0/3	0/5	0/5	2/5	3/5	0/5	0/5	1/5	2/5	8/40
B	0/3	0/5	0/5	0/5	0/5	0/5	0/5	0/5	0/5	0/40
C	0/3	0/5	0/5	0/5	1/5	0/5	0/5	0/5	1/5	2/40
D	0/3	0/5	0/5	0/5	0/5	0/5	0/5	0/5	0/5	0/40
E	0/3	0/5	1/5	0/5	0/5	0/5	0/5	1/5	0/5	2/40

- Plain bar had 4 failures, with Stew and Water.
- Bar A had 8 failures, with Stew and Rice.
- Bar C had 2 failures, with Stew and Rice.
- Bar E had 2 failures, with Rice and Water.
- Bars B & D had no failures.

IP Test Results

440°F - HFFS										
Pattern/Cont.	Clean	Water1	Water2	Stew1	Stew2	Fruit1	Fruit2	Rice1	Rice2	Total
Plain	0/3	1/5	0/5	1/5	1/5	3/5	1/5	1/5	0/5	8/40
A	0/3	0/5	0/5	0/5	0/5	0/5	0/5	0/5	0/5	0/40
B	0/3	0/5	0/5	0/5	0/5	0/5	0/5	0/5	0/5	0/40
C	0/3	0/5	0/5	0/5	0/5	0/5	2/5	1/5	1/5	4/40
D	0/3	0/5	0/5	0/5	0/5	0/5	0/5	0/5	0/5	0/40
E	0/3	0/5	0/5	0/5	0/5	0/5	0/5	0/5	0/5	0/40

- Plain bar had 8 failures; in all categories.
- Bar C had 4 failures; with Fruit and Rice.
- Bars A, B, D, & E had no failures.

Peel Test Data

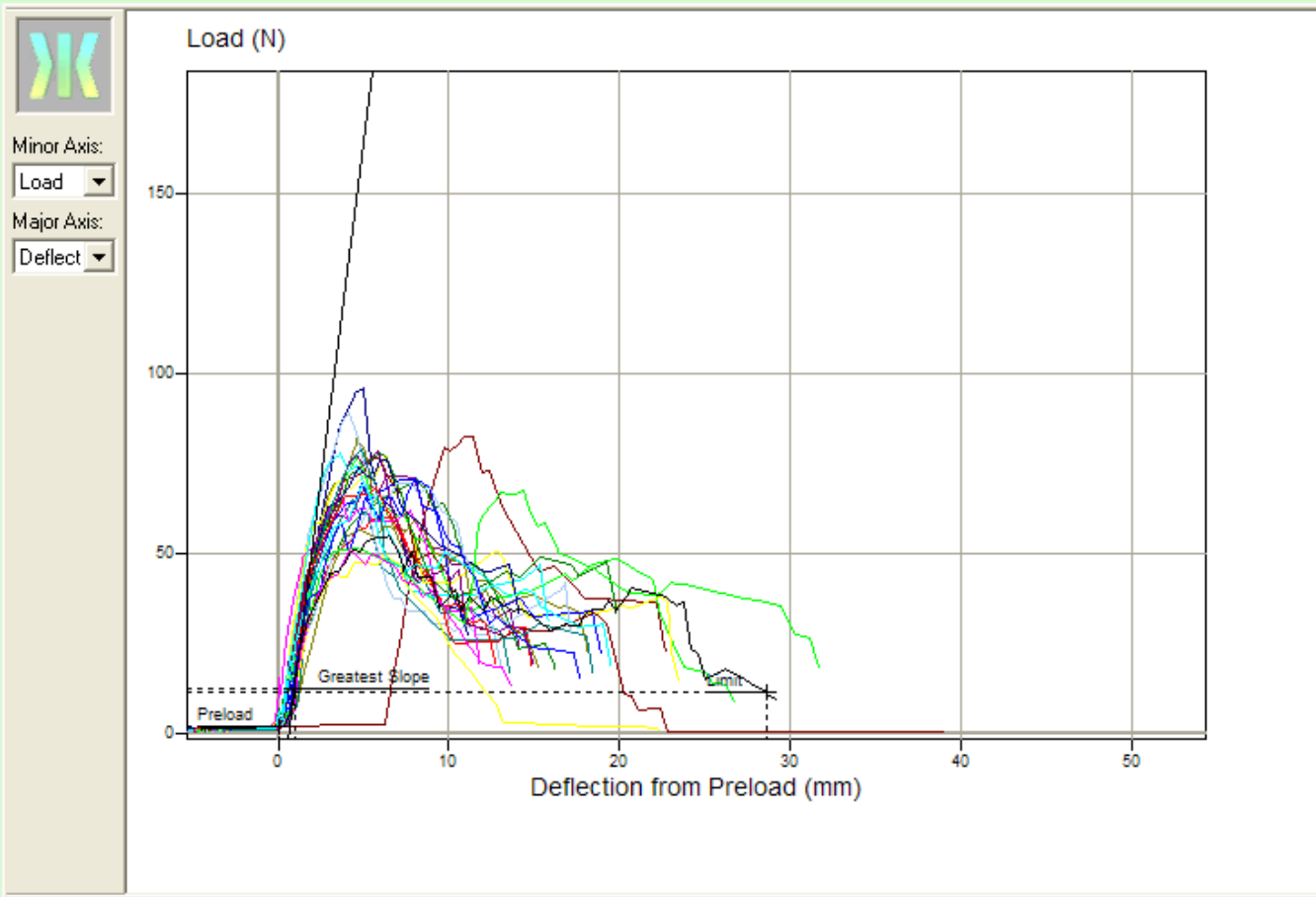

- Force plot of all tests for Bar B
Fruit1 and Fruit2 at 325°F

Peel Test Data

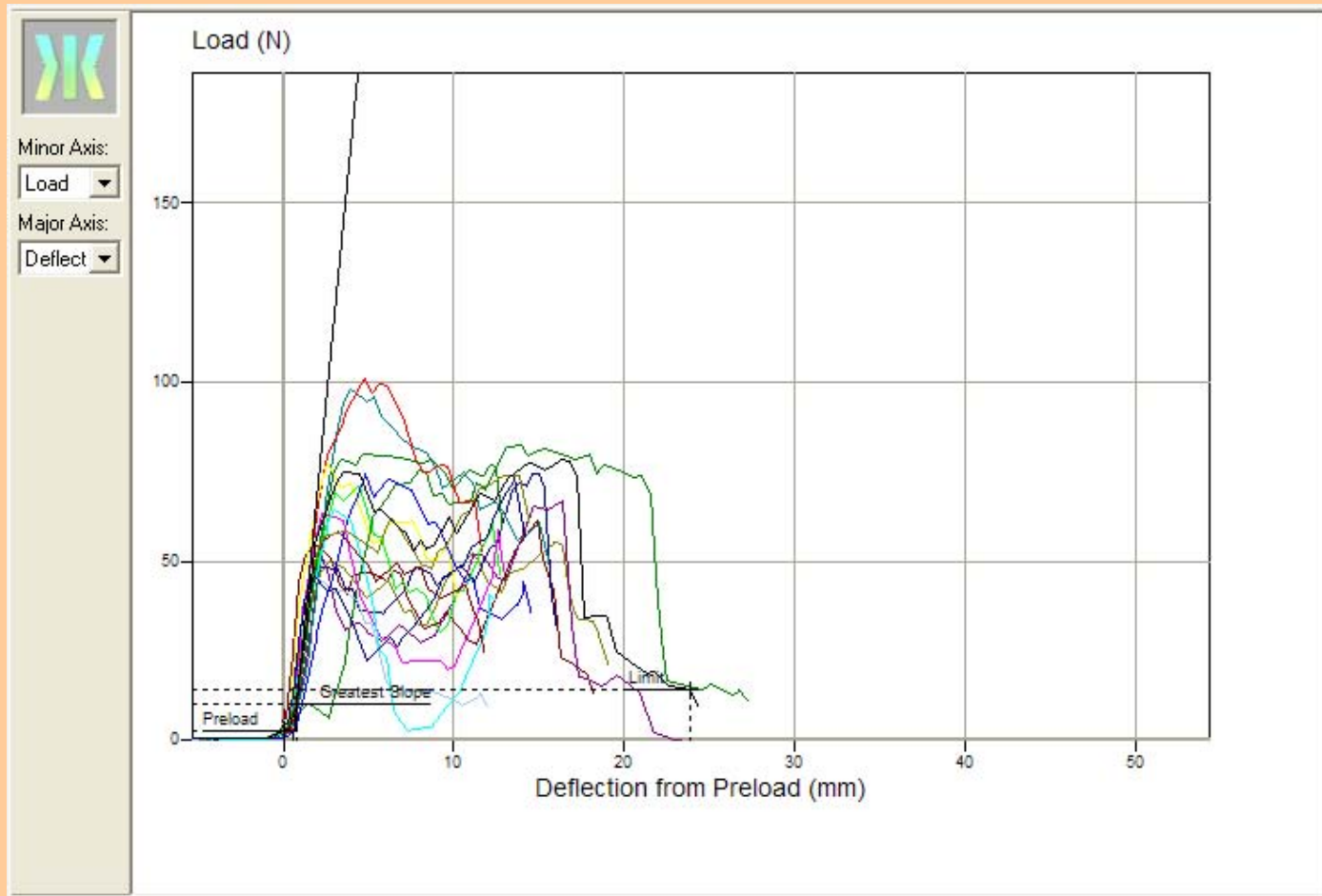

- Force plot of all tests for Plain Bar Fruit1 and Fruit2 at 440°F

Peel Test Summary Plot

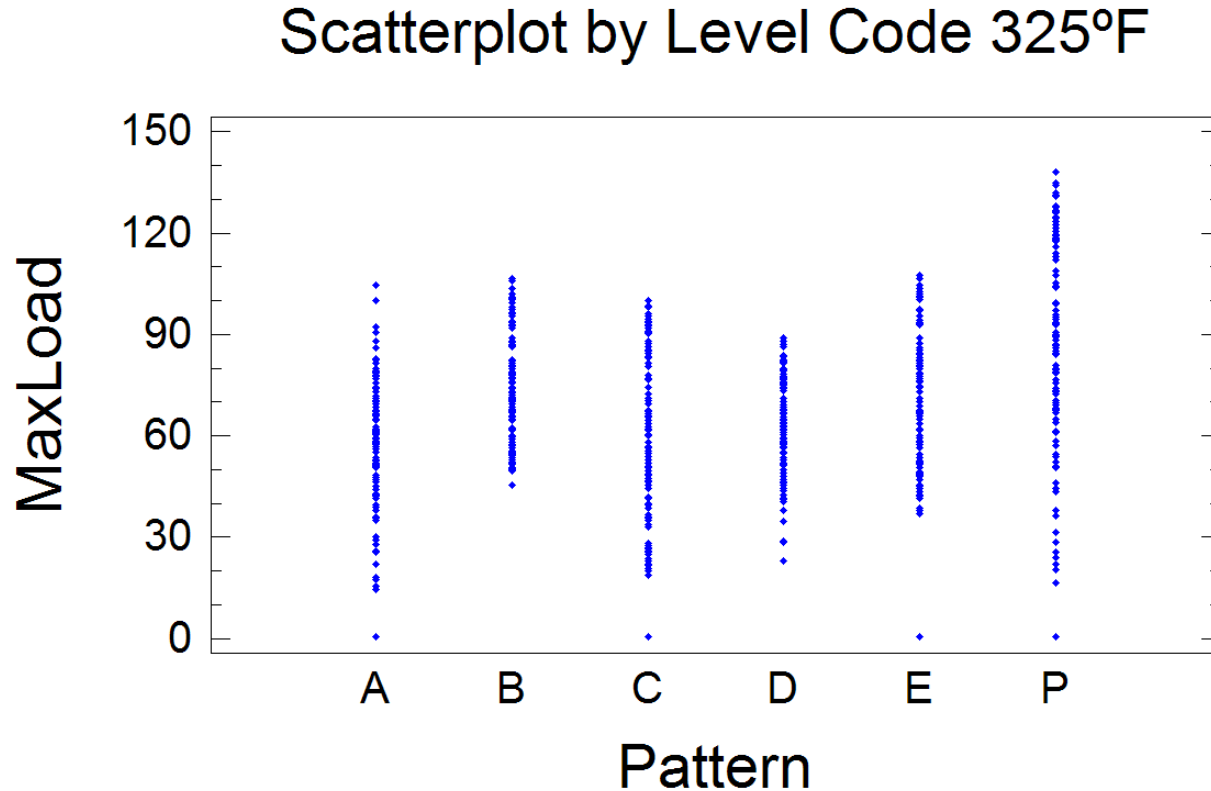

- Bars A, C, E, and Plain had samples below acceptable seal strength
- Bars B and D had no failures

Peel Test Summary Plot

Scatterplot by Level Code 440°F

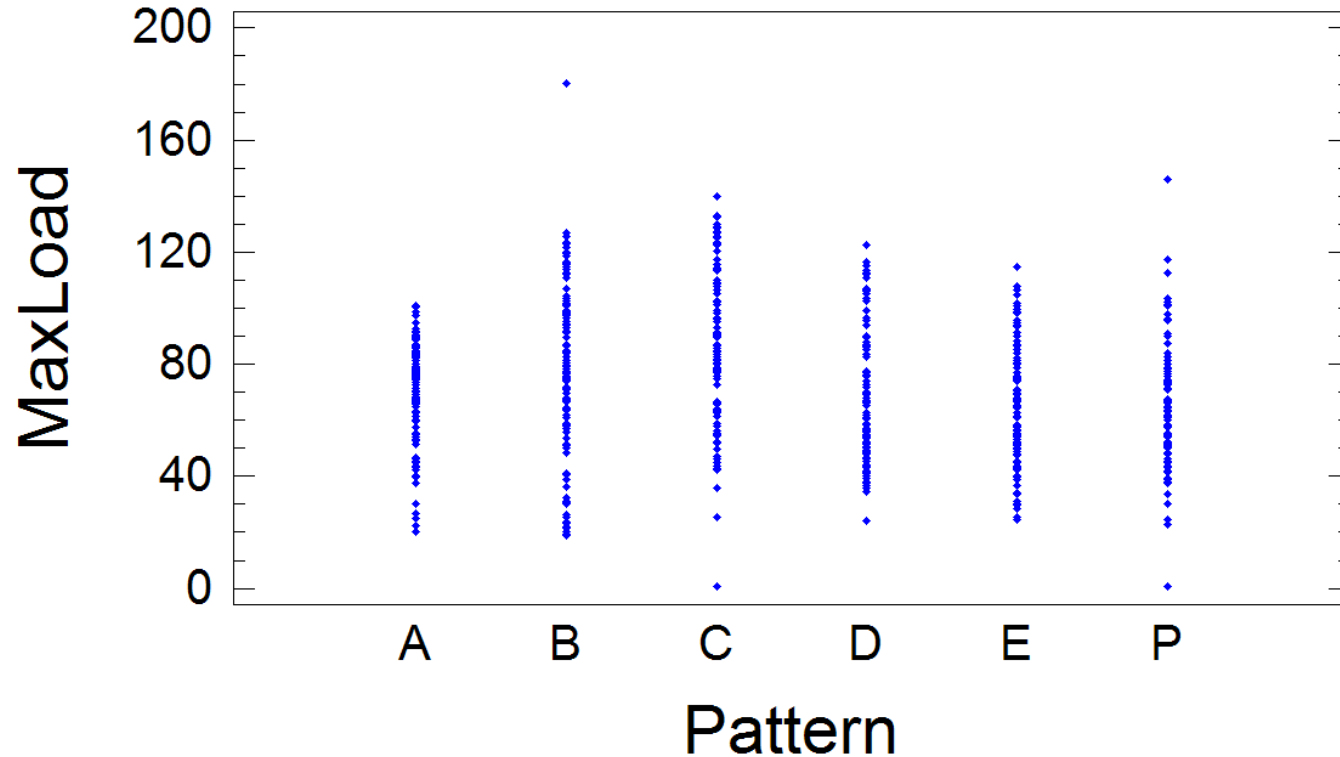

- Bars C and Plain had failing samples
- Bars A, B, D, and E had no failures

Process Control Chart

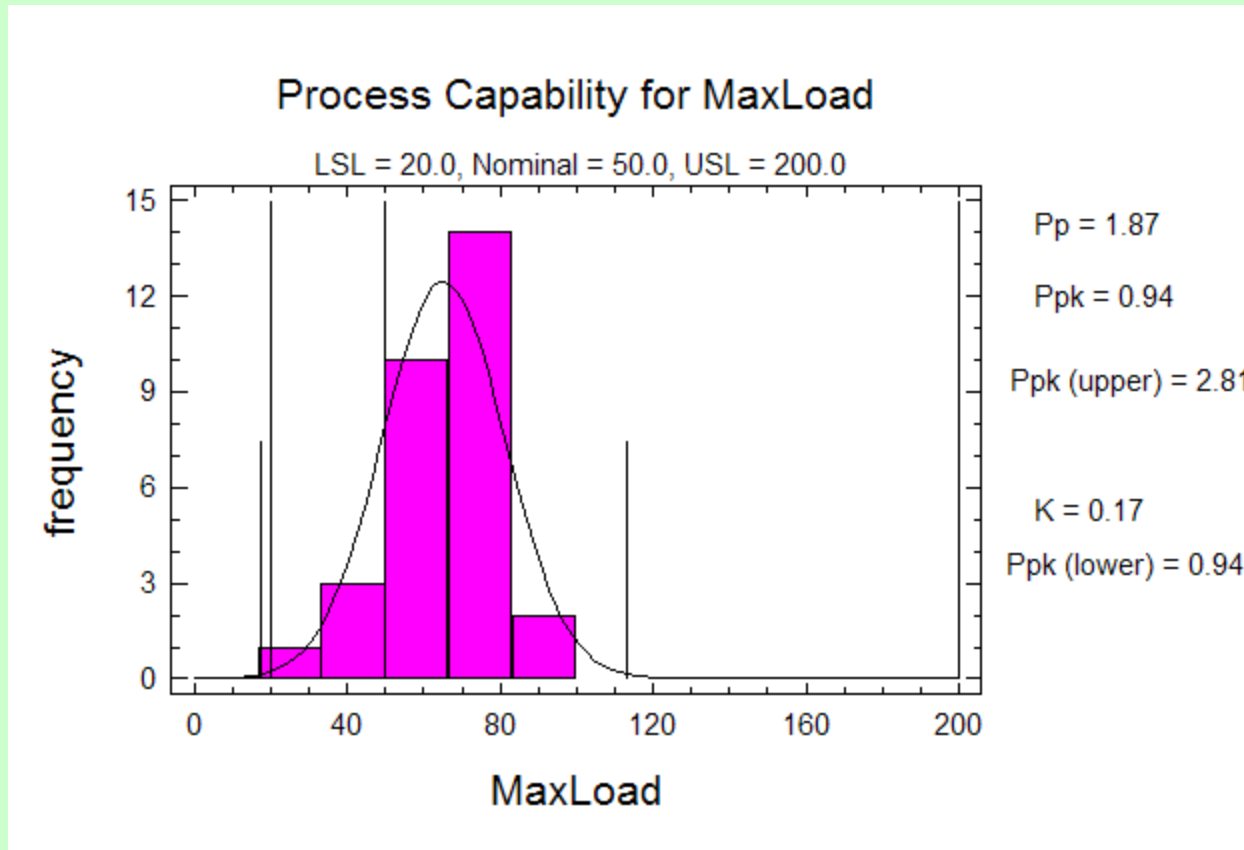

- Bar A 325°F, Water1 and Water2

Process Control Summary

Analysis Summary

Data variable: MaxLoad

Selection variable: Pattern="A" & Temp=325 & Contaminate="W"

Distribution: Normal

sample size = 30

mean = 65.2083

standard deviation = 16.0166

6.0 Sigma Limits

+3.0 sigma = 113.258

mean = 65.2083

-3.0 sigma = 17.1585

Specifications	Observed Beyond Spec.	Z-Score	Estimated Beyond Spec.	Defects Per Million
USL = 200.0	0.000000%	8.42	0.000000%	0.00
Nominal = 50.0				
LSL = 20.0	0.000000%	-2.82	0.238193%	2381.93
Total	0.000000%		0.238193%	2381.93

The StatAdvisor

This procedure is designed to compare a set of data against a set of specifications. The goal of the analysis is to estimate the proportion of the population from which that data comes which falls outside the specification limits. In this case, a normal distribution was fit to a set of 30 observations in the variable MaxLoad. 0.238193% of the fitted distribution lies outside the specification limits. If the normal distribution is appropriate for the data, this estimates the percent of the population which lies outside the spec.

To determine whether the normal distribution is appropriate for this data, select Goodness-of-Fit Tests from the list of Tabular Options. You can assess the fit visually by selecting Capability Plot from the list of Graphical Options.

- Bar A 325°F, Water1 and Water2

Process Capability 6 Sigma Defects

Pattern	Defects/Million Pouches 325°F				
	Clean	Water	Stew	Fruit	Rice
Plain	0	11937	278365	4410	3668
A	0	2382	614582	98	152128
B	0	0	2	1	87
C	0	0	248978	1122	72644
D	0	0	2	32	6780
E	0	13478	3476	285	69725

*Based on Lower Control Limits of 20 N peel strength, +-3 sigma from means

- Bar A had many more predicted failures with Stew and Rice than the plain bars.
- **Bar B significantly fewer predicted failures with all contaminants compared to the plain bars.**
- Bar C had similar predicted failures with Stew and many more with Rice than the plain bars.
- Bar D had more predicted failures with Rice than the plain bars.
- Bar E had similar predicted failures with Water and many more with Rice than the plain bars.

Process Capability 6 Sigma Defects

Pattern	Defects/Million Pouches 440°F				
	Contaminate				
	Clean	Water	Stew	Fruit	Rice
Plain	0	39379	179997	196655	154932
A	0	0	45315	1	103
B	0	0	5	14586	112974
C	0	67	164	75813	187489
D	0	3601	1231	578	18689
E	0	0	478	184	51593

*Based on Lower Control Limits of 20 N peel strength, +-3 sigma from means

- **Bar A significantly fewer predicted failures with all contaminants compared to the plain bars.**
- **Bar B significantly fewer predicted failures with most contaminants except similar failures for Rice, compared to the plain bars.**
- Bar C significantly fewer predicted failures with most contaminants except more with Rice, compared to the plain bars.
- **Bars D & E had significantly fewer predicted failures with all contaminants compared to the plain bars.**

Next Steps



- Conduct sensitivity analysis on sealing parameters to model optimum conditions of the two candidate bars, B (45° 30TPI flat cuts) & D (120° 20TPI pointed Diamonds)
- Distribute findings and recommend specific bars
- Begin Phase II tasks

STP#2024 Scope of Work - Phase II

- Recommend Knurled Seal Bar Design
 - In cooperation with Industry Partners, sealing equipment will be selected for new knurled seal bars. Bars will be designed and manufactured based on Phase I results

STP#2024 Scope of Work - Phase II

- Implementation and Performance Monitoring
 - Rejection rate due to entrapped matter will be determined in before/after retort inspection phases.
 - After adequate data is collected, knurled seal bars will be installed and sealing conditions fine tuned as if necessary.
 - Initially, frequent samples will be pulled off line for a seal strength tests to assure that no product is produced that does not meet the military requirements.
 - After the initial validation step, product will be produced using the same procedures as the “flat bar” sealing process.
 - Data will be collected on rejects rates of seals with entrapped matter, during before or after retort visual inspection phases.
 - As a secondary implementation step, labor for cleaning seals may be reduced. The effect of this on the overall reject rate will be studied. Data will be collected on rejects rates of seals with entrapped matter, during before/after retort visual inspection phase.

STP#2024 Scope of Work - Phase II

- Updating Cost Benefit Analysis
 - Based on the cost of the knurled seal bar and the reject rates documented in the above test, we will update the cost benefit analysis of this project.

Appendix 4.5

Workshop 20, November 2007

Effectiveness of a Knurled Heat Seal Bar, STP2024



**Benchtop Heat Sealer,
Wrap-Ade® Model K**

OBJECTIVE

Evaluate the effect of knurled seal bar patterns on sealing strength through contaminants.
Recommend bar pattern and transfer technology to production
Document cost / benefit of implementation

BENEFITS

- Potential for improved seal strength when contamination present, more robust sealing systems
- Low cost and quick implementation
- Reduction in lot rejections due to leakers/weak seals

BUSINESS STRATEGY

- Annual Ration Production: Tray Pack and MRE Production
- Developing Partners: Ameriquel, Sopakco, Wornick, Rutgers, Wrapade Packaging Systems
- Demonstration Site: Rutgers FMT Facility
- Production Site: TBD
- Project Duration: 18 months

Related Efforts

- **CORANET STP1013 – Feasibility Study Ultrasonic Sealing of MRE pouches**
- **STP2004 Ultrasonic Sealing MRE Production**

IMPLEMENTATION

- **Phase I: Bench Top Evaluation**
- **Phase II: Production Scale Evaluation**

Knurled Heat Seal Bars – Recent Activities

- **Thermocouples replaced**
 - Pressed wire contacts uncoupled after two change outs
 - A welded single piece design was sourced and installed
 - New thermocouples react faster to temp changes
- **Initial testing and data analysis complete**
- **IPR meetings at FMT Facility October 11th**
 - **Burst testing results and peel strength measurements presented**
 - Contaminates used; Beef Stew (MRE), Rice (Mexican, MRE), Fruit Cocktail (MRE), and water with one or both sides heavily smeared.
 - 2 of the 5 patterns produced significantly stronger seals than flat bars

IP Test Results

325°F - Vertical Fill

Pattern/Cont.	Clean	Water1	Water2	Stew1	Stew2	Fruit1	Fruit2	Rice1	Rice2	Total
Plain	0/3	1/5	0/5	1/5	2/5	0/5	0/5	0/5	0/5	4/40
A	0/3	0/5	0/5	2/5	3/5	0/5	0/5	1/5	2/5	8/40
B	0/3	0/5	0/5	0/5	0/5	0/5	0/5	0/5	0/5	0/40
C	0/3	0/5	0/5	0/5	1/5	0/5	0/5	0/5	1/5	2/40
D	0/3	0/5	0/5	0/5	0/5	0/5	0/5	0/5	0/5	0/40
E	0/3	0/5	1/5	0/5	0/5	0/5	0/5	1/5	0/5	2/40

- Plain bar had 4 failures, with Stew and Water.
- Bar A had 8 failures, with Stew and Rice.
- Bar C had 2 failures, with Stew and Rice.
- Bar E had 2 failures, with Rice and Water.
- Bars B & D had no failures.

IP Test Results

440°F - HFFS

Pattern/Cont.	Clean	Water1	Water2	Stew1	Stew2	Fruit1	Fruit2	Rice1	Rice2	Total
Plain	0/3	1/5	0/5	1/5	1/5	3/5	1/5	1/5	0/5	8/40
A	0/3	0/5	0/5	0/5	0/5	0/5	0/5	0/5	0/5	0/40
B	0/3	0/5	0/5	0/5	0/5	0/5	0/5	0/5	0/5	0/40
C	0/3	0/5	0/5	0/5	0/5	0/5	2/5	1/5	1/5	4/40
D	0/3	0/5	0/5	0/5	0/5	0/5	0/5	0/5	0/5	0/40
E	0/3	0/5	0/5	0/5	0/5	0/5	0/5	0/5	0/5	0/40

- Plain bar had 8 failures; in all categories.
- Bar C had 4 failures; with Fruit and Rice.
- Bars A, B, D, & E had no failures.

Process Capability 6 Sigma Defects

Defects/Million Pouches 325°F

Pattern	Contaminate				
	Clean	Water	Stew	Fruit	Rice
Plain	0	11937	278365	4410	3668
A	0	2382	614582	98	152128
B	0	0	2	1	87
C	0	0	248978	1122	72644
D	0	0	2	32	6780
E	0	13478	3476	285	69725

*Based on Lower Control Limits of 20 N peel strength, +/-3 sigma from means

- Bar A had many more predicted failures with Stew and Rice than the plain bars.
- **Bar B significantly fewer predicted failures with all contaminates compared to the plain bars.**
- Bar C had similar predicted failures with Stew and many more with Rice than the plain bars.
- Bar D had more predicted failures with Rice than the plain bars.
- Bar E had similar predicted failures with Water and many more with Rice than the plain bars.

Process Capability 6 Sigma Defects

Defects/Million Pouches 440°F

Pattern	Contaminate				
	Clean	Water	Stew	Fruit	Rice
Plain	0	39379	179997	196655	154932
A	0	0	45315	1	103
B	0	0	5	14586	112974
C	0	67	164	75813	187489
D	0	3601	1231	578	18689
E	0	0	478	184	51593

*Based on Lower Control Limits of 20 N peel strength, ± 3 sigma from means

- **Bar A significantly fewer predicted failures with all contaminants compared to the plain bars.**
- **Bar B significantly fewer predicted failures with most contaminants except similar failures for Rice, compared to the plain bars.**
- Bar C significantly fewer predicted failures with most contaminants except more with Rice, compared to the plain bars.
- **Bars D & E had significantly fewer predicted failures with all contaminants compared to the plain bars.**

Next Steps



- Identify a functional film delaminating agent
 - 50% acetic acid, Methyl Ethyl Ketone, and Xylene were not effective
- Continue sensitivity analysis on sealing parameters to model optimum conditions of the two candidate bars, B (45° 30TPI flat cuts) & D (120° 20TPI pointed Diamonds)
- Distribute findings and recommend specific bars
- Begin Phase II tasks; In-Plant Implementation

Appendix 4.6

Workshop 21, April 2008

Effectiveness of a Knurled Heat Seal Bar, STP2024



**Benchtop Heat Sealer,
Wrap-Ade® Model K**

OBJECTIVE

Evaluate the effect of knurled seal bar patterns on sealing strength through contaminants.
Recommend bar pattern and transfer technology to production
Document cost / benefit of implementation

BENEFITS

- Potential for improved seal strength when contamination present, more robust sealing systems
- Low cost and quick implementation
- Reduction in lot rejections due to leakers/weak seals

BUSINESS STRATEGY

- Annual Ration Production: Tray Pack and MRE Production
- Developing Partners: Ameriquial, Sopakco, Wornick, Rutgers, Wrapade Packaging Systems
- Demonstration Site: Rutgers FMT Facility
- Production Site: TBD
- Project Duration: 18 months

Related Efforts

- **CORANET STP1013 – Feasibility Study Ultrasonic Sealing of MRE pouches**
- **STP2004 Ultrasonic Sealing MRE Production**

IMPLEMENTATION

- **Phase I: Bench Top Evaluation**
- **Phase II: Production Scale Evaluation**

Knurled Heat Seal Bars – Recent Activities

- Chemical peel / delamination study
 - Successful Method; 50% acetic acid @ 180°F for 3 days
 - Contaminates encapsulated in grid of sealant
 - Grid patterns from localized pressure had good seals
 - Some larger meat fibers spanned multiple grids
 - Cooling bars could reduce seal strength of gross contamination if the grid is compressed and popped
 - Cooling bar seal interaction should be reviewed in plant

Knurled Heat Seal Bars – Recent Activities

- Sensitivity analysis
 - Quantify interaction of sealing conditions with Patterns B(45° 30TPI cuts) & D (120° 20TPI diamonds)
 - Both seal sides smeared with Beef Stew or Mexican Rice
 - Baseline conditions from flat bar study increased
 - Vertical Fill 325°F to 340°F, HFFS 440°F to 455°F
 - Vertical Fill 45psi to 55psi, HFFS 25psi to 35psi
 - Vertical Fill 0.9 to 1.1sec, HFFS 1.2 to 1.4sec

Vertical Fill - Temperature

Means and 95.0 Percent Confidence Intervals

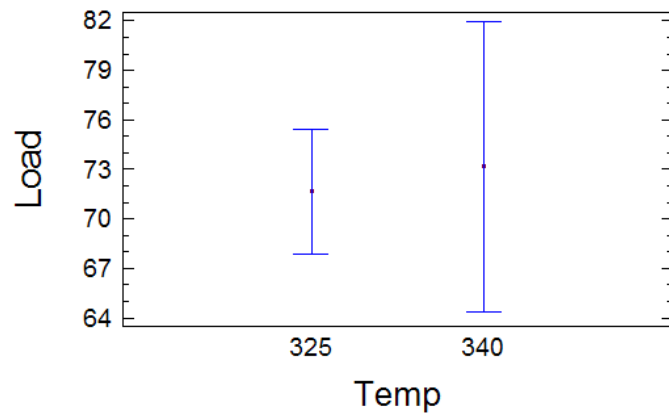

Bar B

Means and 95.0 Percent Confidence Intervals

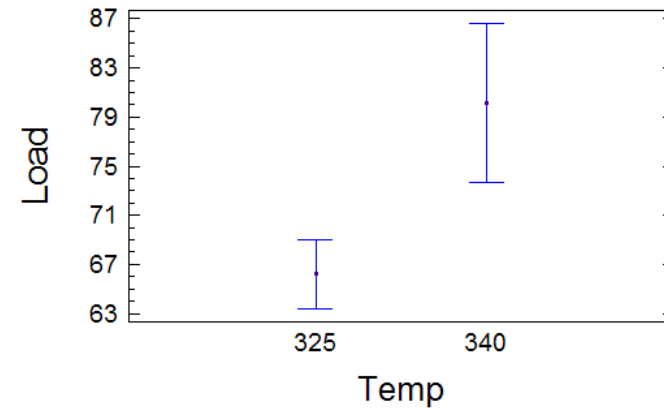

Bar D

- Bar B showed a slight change with higher temp.
- Bar D showed improved seal strength with more heat.

HFFS - Temperature

Means and 95.0 Percent Confidence Intervals

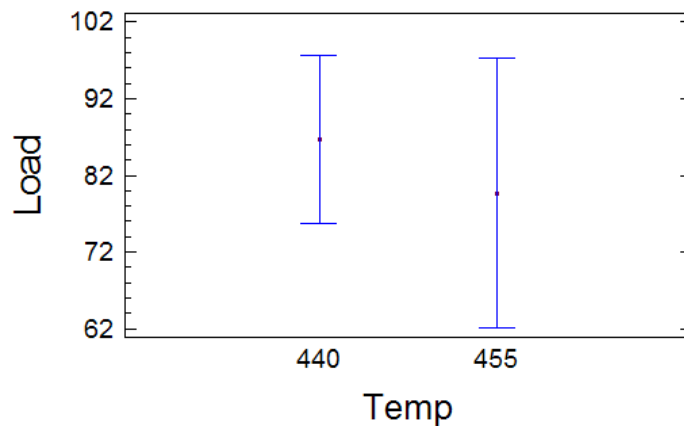

Bar B

Means and 95.0 Percent Confidence Intervals

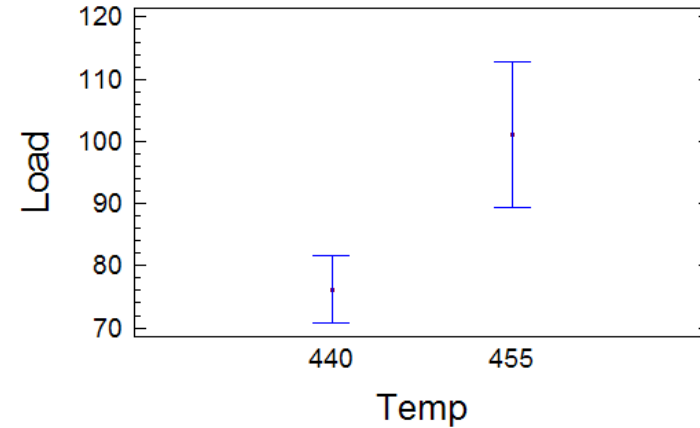

Bar D

- Bar B showed no significant change with higher temp.
- Bar D showed improved seal strength with more heat.

Vertical Fill - Pressure

Means and 95.0 Percent Confidence Intervals

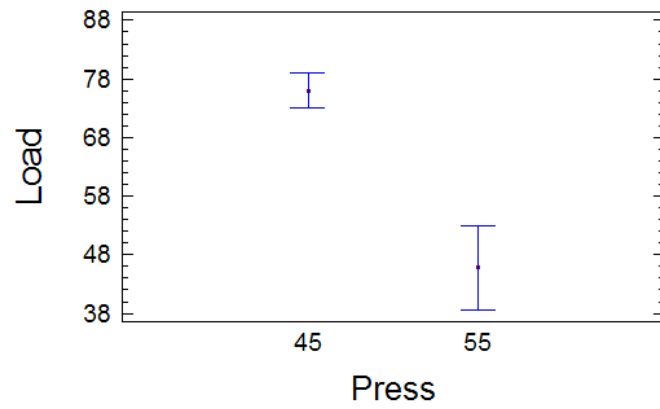

Bar B

Means and 95.0 Percent Confidence Intervals

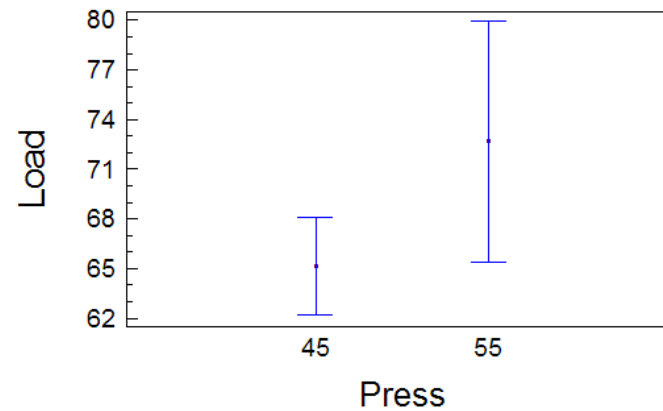

Bar D

- Bar B showed decrease in seal strength
- Bar D showed improved seal strength

HFFS - Pressure

Means and 95.0 Percent Confidence Intervals

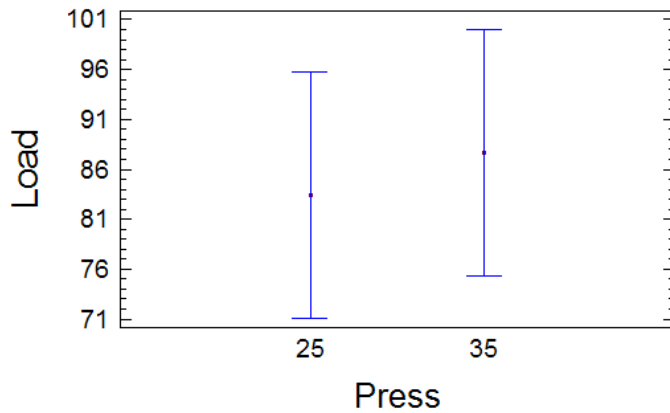

Bar B

Means and 95.0 Percent Confidence Intervals

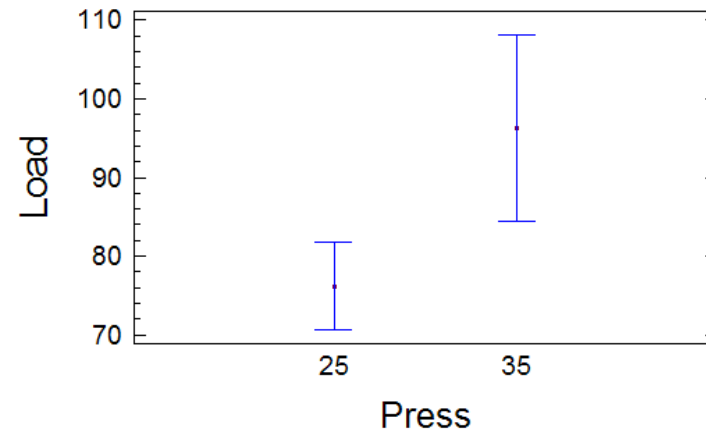

Bar D

- Bar B showed no significant change
- Bar D showed improved seal strength with pressure

Vertical Fill - Time

Means and 95.0 Percent Confidence Intervals

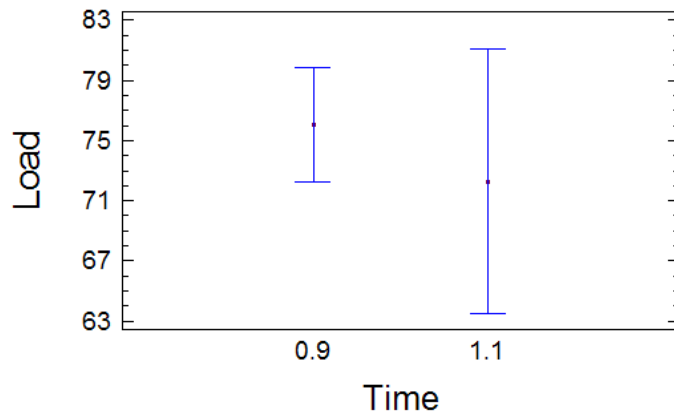

Bar B

Means and 95.0 Percent Confidence Intervals

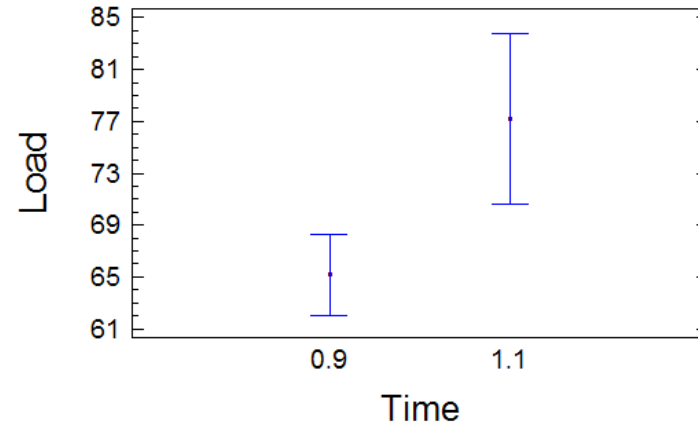

Bar D

- Bar B showed slight decrease with more seal time
- Bar D showed improved seal strength with more time.

HFFS - Time

Means and 95.0 Percent Confidence Intervals

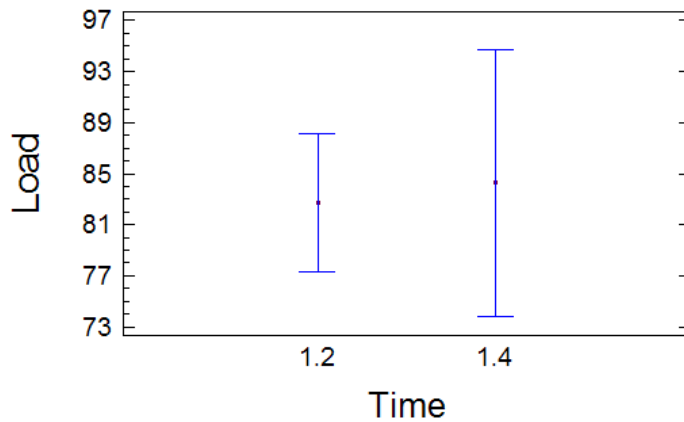

Bar B

Means and 95.0 Percent Confidence Intervals

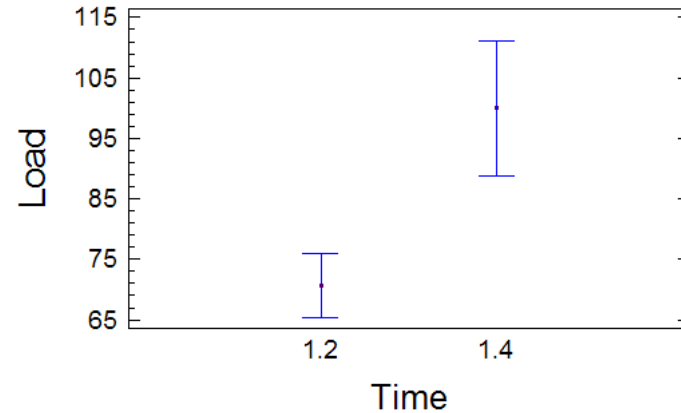

Bar D

- Bar B; no significant change with more seal time.
- Bar D showed improved seal strength with more time.

Next Steps



- Seal interaction with cooling bars cannot be studied due to lack of equipment
 - Interaction should be reviewed in plant
- Begin Phase II; In-Plant Implementation
 - Bar D pattern is recommend based on the data
 - Increasing time/pressure/temperature from current settings will increase seal strength with bar D

Appendix 4.7

Workshop 22, July 2008

Effectiveness of a Knurled Heat Seal Bar, STP2024



**Benchtop Heat Sealer,
Wrap-Ade® Model K**

OBJECTIVE

Evaluate the effect of knurled seal bar patterns on sealing strength through contaminants.
Recommend bar pattern and transfer technology to production
Document cost / benefit of implementation

BENEFIT

- Potential for improved seal strength when contamination present, more robust sealing systems
- Low cost and quick implementation
- Reduction in lot rejections due to leakers/weak seals

BUSINESS STRATEGY

- Annual Ration Production: Tray Pack and MRE Production
- Developing Partners: Ameriquel, Sopakco, Wornick, Rutgers, Wrapade Packaging Systems
- Demonstration Site: Rutgers FMT Facility
- Production Site: TBD
- Project Duration: 18 months

Related Efforts

- **CORANET STP1013 – Feasibility Study Ultrasonic Sealing of MRE pouches**
- **STP2004 Ultrasonic Sealing MRE Production**

IMPLEMENTATION

- **Phase I: Bench Top Evaluation (Complete)**
- **Phase II: Production Scale Evaluation**

Knurled Heat Seal Bars

- Seal interaction with cooling bars in vertical fill applications cannot be studied at the FMT Facility; sealer lacks cooling bars
 - Interaction should be studied in-plant
- Bar D pattern is recommend for vertical fill
- Increasing time/pressure/temperature from current plant settings will increase seal strength with bar D
- Pattern B or Pattern E are both recommended for HFFS machines
 - Initial results with HFFS show pattern E performs marginally better than B
- No change in plant sealing conditions is recommended with pattern B
- The developing partner has requested a HFFS plate be provided for in-plant implementation
 - Significant production is required to validate the study
 - Use in their main production line would provide data without having to dedicate resources specifically to the validation study

Next Steps



- Continue Phase II tasks
- Visit partner plant for data collection and sampling protocol development
- Document and analyze in-plant results
- Update cost/benefit analysis

Appendix 4.8

Workshop 1, December 2008

Effectiveness of a Knurled Heat Seal Bar, STP2024



**Benchtop Heat Sealer,
Wrap-Ade Model K**

OBJECTIVE

Evaluate the effect of knurled seal bar patterns on sealing strength through contaminants.
Recommend bar pattern and transfer technology to production
Document cost / benefit of implementation

BENEFITS

- Potential for improved seal strength when contamination present, more robust sealing systems
- Low cost and quick implementation
- Reduction in lot rejections due to leakers/weak seals

BUSINESS STRATEGY

- Annual Ration Production: Tray Pack and MRE Production
- Developing Partners: Ameriquial, Sopakco, Wornick, Rutgers, Wrapade Packaging Systems
- Demonstration Site: Rutgers FMT Facility
- Production Site: TBD
- Project Duration: 18 months

Related Efforts

- **CORANET STP1013 – Feasibility Study Ultrasonic Sealing of MRE pouches**
- **STP2004 Ultrasonic Sealing MRE Production**

IMPLEMENTATION

- **Phase I: Bench Top Evaluation (Complete)**
- **Phase II: Production Scale Evaluation**

Knurled Heat Seal Bars – Recent Activities

- Commercial heat seal manufacturer shipped patterned heat plates to Ameriqua 12/08
 - Pattern diagram provided by Wrapade included an error in the knurl height
 - Manufacturer engineering altered the pattern dimensions to match the incorrect height without consultation
 - Resultant knurl was 2x too large, 10tpi vs. 20tpi
 - Adequate seals could not be made with the 10tpi pattern in production, film perforated
- Wrapade bar with intended 20tpi knurl pattern was sent to Manufacturer for measurement verification

Next Steps



- Production sealing plates to be returned for proper pattern cutting at Manufacturer or replacement
- Challenge study to be coordinated based on plate turn-around and production scheduling at Ameriqua

Appendix 4.9

Workshop 4, October 2009

Effectiveness of a Knurled Heat Seal Bar, STP2024



**Benchtop Heat Sealer,
Wrap-Ade Model K**

OBJECTIVE

Evaluate the effect of knurled seal bar patterns on sealing strength through contaminants.
Recommend bar pattern and transfer technology to production
Document cost / benefit of implementation

BENEFITS

- Potential for improved seal strength when contamination present, more robust sealing systems
- Low cost and quick implementation
- Reduction in lot rejections due to leakers/weak seals

BUSINESS STRATEGY

- Annual Ration Production: Tray Pack and MRE Production
- Developing Partners: Ameriquel, Sopakco, Wornick, Rutgers, Wrapade Packaging Systems
- Demonstration Site: Rutgers FMT Facility
- Production Site: Ameriquel
- Project Duration: 18 months

Related Efforts

- **CORANET STP1013 – Feasibility Study Ultrasonic Sealing of MRE pouches**
- **STP2004 Ultrasonic Sealing MRE Production**

IMPLEMENTATION

- **Phase I: Bench Top Evaluation (Complete)**
- **Phase II: Production Scale Evaluation (In Progress)**

Knurled Heat Seal Bars – Recent Activities

- Initial production study at Ameriquel Sept 09
 - Attended by Peter Sherman and Robert Trottier
 - Contamination protocol reviewed and tested
 - Control, clean seals
 - Light smearing 100% of seal area
 - Heavy smear in small area on each side
 - Sample pouches retorted and shipped to Rutgers
- Flat bottom sealing rubbers to be replaced with rounded bottom gaskets
- Validation study to be scheduled at Ameriquel when rounded gaskets shipped in November

Next Steps



- Validate flat rubber deficiency on One-up tester
- Trip to Ameriquel for challenge study
- Pouch validation tests
 - All pressure tested 30 second @ 20psi
 - Half pressure to failure test
 - Half subjected to peel strength measurement
- Record and Analyze testing data
- Collect production data for 3 months
- Collect Cost / Benefit data from producer
- Issue Final Report

Appendix 4.10

Workshop 5, March 2010

Effectiveness of a Knurled Heat Seal Bar, STP2024



**Benchtop Heat Sealer,
Wrap-Ade Model K**

OBJECTIVE

Evaluate the effect of knurled seal bar patterns on sealing strength through contaminates.
Recommend bar pattern and transfer technology to production
Document cost / benefit of implementation

BENEFITS

- Potential for improved seal strength when contamination present, more robust sealing systems
- Low cost and quick implementation
- Reduction in lot rejections due to leakers/weak seals

BUSINESS STRATEGY

- Annual Ration Production: Tray Pack and MRE Production
- Developing Partners: Ameriquel, Sopakco, Wornick, Rutgers, Wrapade Packaging Systems
- Demonstration Site: Rutgers FMT Facility
- Production Site: Ameriquel
- Project Duration: 18 months

Related Efforts

- **CORANET STP1013 – Feasibility Study Ultrasonic Sealing of MRE pouches**
- **STP2004 Ultrasonic Sealing MRE Production**

IMPLEMENTATION

- **Phase I: Bench Top Evaluation (Complete)**
- **Phase II: Production Scale Evaluation (In Progress)**

Knurled Heat Seal Bars – Recent Activities

- Testing on One-Up sealer confirms Flat bottom sealing rubbers cause open seals when contamination present
- Delay in Rounded gasket purchase approval caused project to slip 3 months
- Rounded bottom sealing rubbers shipped and installed to replace Flat bottom gaskets
- Validation study to be scheduled at Ameriquel asap

Next Steps



- Trip to Ameriquil for challenge study
- Pouch validation tests
 - All pressure tested 30 second @ 20psi
 - Half pressure to failure test
 - Half subjected to peel strength measurement
- Record and Analyze testing data
- Collect production data for 3 months
- Collect Cost / Benefit data from producer
- Issue Final Report

Appendix 4.11

Knurl Pattern Schematic

REV.	DESCRIPTION	DATE	BY

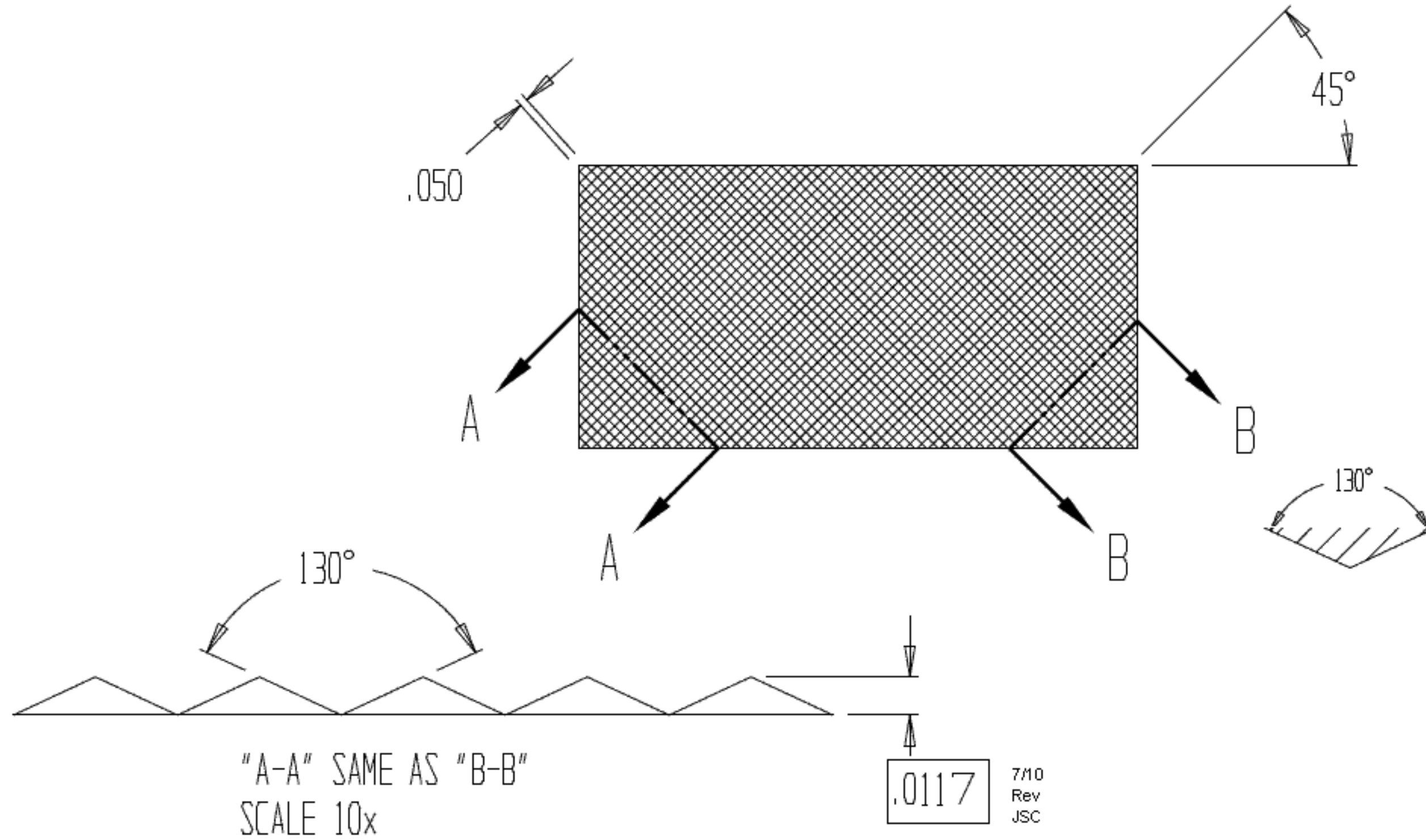

X	
QTY	BM #

UNLESS OTHERWISE SPECIFIED Dimensional Tolerances		WRAPADE PACKAGING SYSTEMS, LLC. NEW JERSEY - U.S.A.	
FRAC	DEC	ANG	INFORMATION IS PRIVATE PROPERTY, AND IS NOT TO BE SHARED WITHOUT WRITTEN AUTHORIZATION
±1/64	±.005	±1/2°	
Reference X	DRAWN	DATE	SIMILAR DWG.
	WNO	5/4/07	X
TITLE	DATE	Rev	SCALE 1:1
20TPI 45 DEGREE	7/10	JSC	SHEET 1 OF 1
			DRAWING NUMBER
			B25967
			REV
			7/10
			Rev
			JSC