

The Quebec Liberation Front (FLQ) as an Insurgency

**A Monograph
by
LTC Alain Carrier
Canadian Military Engineers**



**School of Advanced Military Studies
United States Army Command and General Staff College
Fort Leavenworth, Kansas**

AY 2009-10

REPORT DOCUMENTATION PAGE

Form Approved
OMB No. 0704-0188

Public reporting burden for this collection of information is estimated to average 1 hour per response, including the time for reviewing instructions, searching existing data sources, gathering and maintaining the data needed, and completing and reviewing this collection of information. Send comments regarding this burden estimate or any other aspect of this collection of information, including suggestions for reducing this burden to Department of Defense, Washington Headquarters Services, Directorate for Information Operations and Reports (0704-0188), 1215 Jefferson Davis Highway, Suite 1204, Arlington, VA 22202-4302. Respondents should be aware that notwithstanding any other provision of law, no person shall be subject to any penalty for failing to comply with a collection of information if it does not display a currently valid OMB control number. **PLEASE DO NOT RETURN YOUR FORM TO THE ABOVE ADDRESS.**

| | | | | | | |
|--|--------------------|---------------------|---|----------------------------|---|--|
| 1. REPORT DATE (DD-MM-YYYY) 08-04-2010 | | | 2. REPORT TYPE SAMS Monograph | | 3. DATES COVERED (From - To) JUL 2009 – MAY 2010 | |
| 4. TITLE AND SUBTITLE The Quebec Liberation Front (FLQ) as an Insurgency. | | | | | 5a. CONTRACT NUMBER | |
| | | | | | 5b. GRANT NUMBER | |
| | | | | | 5c. PROGRAM ELEMENT NUMBER | |
| 6. AUTHOR(S) LTC Alain Carrier | | | | | 5d. PROJECT NUMBER | |
| | | | | | 5e. TASK NUMBER | |
| | | | | | 5f. WORK UNIT NUMBER | |
| 7. PERFORMING ORGANIZATION NAME(S) AND ADDRESS(ES) U.S. Army Command and General Staff College ATTN: ATZL-SWD-GD Fort Leavenworth, KS 66027-2301 | | | | | 8. PERFORMING ORG REPORT NUMBER | |
| 9. SPONSORING / MONITORING AGENCY NAME(S) AND ADDRESS(ES) | | | | | 10. SPONSOR/MONITOR'S ACRONYM(S) | |
| | | | | | 11. SPONSOR/MONITOR'S REPORT NUMBER(S) | |
| 12. DISTRIBUTION / AVAILABILITY STATEMENT Approved for Public Release; Distribution is Unlimited | | | | | | |
| 13. SUPPLEMENTARY NOTES | | | | | | |
| 14. ABSTRACT This monograph demonstrates that the FLQ was an insurgency through the verification of four characteristics common to five insurgency definitions. The Canadian government's initiatives and actions simply kept the FLQ insurgency from moving past the proto-insurgency stage. Theorists like Bard E. O'Neill argue that governments hold the advantage while an insurgency remains only in the making. However, O'Neill also states that governments show complacency judging an insurgency at the proto-insurgency stage too small to warrant any immediate action. The Canadian government avoided that road and chose a more proactive approach to the FLQ. The FLQ insurgency failed to grow past the proto-insurgency stage. Conditions created and actions taken by the government made organizing, self-sustainment, and growing, impossible for the FLQ. As a result, the FLQ insurgency failed. Studying insurgencies at the proto-insurgency level reveals a lot about what an insurgency is and how a government can influence its growth. A study case like the FLQ further highlights how the odds of a government defeating an insurgency become higher, when the insurgency's identification and understanding happen early. However, the government must apply proactive actions and show the willingness to take some risks, including the consideration of an appropriate use of coercive countermeasures. | | | | | | |
| 15. SUBJECT TERMS Quebec Liberation Front (FLQ), Insurgency, Proto-Insurgency Stage. | | | | | | |
| 16. SECURITY CLASSIFICATION OF: | | | 17. LIMITATION OF ABSTRACT | 18. NUMBER OF PAGES | 19a. NAME OF RESPONSIBLE PERSON Stefan A. Banach, U.S. Army | |
| a. REPORT | b. ABSTRACT | c. THIS PAGE | | | 19b. PHONE NUMBER (include area code) 913-758-3302 | |
| (U) | (U) | (U) | (U) | 54 | | |

SCHOOL OF ADVANCED MILITARY STUDIES

MONOGRAPH APPROVAL

LTC Alain Carrier

Title of Monograph: The Quebec Liberation Front (FLQ) as an Insurgency.

Approved by:

Nathan W. Toronto, Ph.D. Monograph Director

CDR Michael Hutchens, USN Seminar Leader / Reader

Joseph R. Fischer, Ph.D. Reader

Stefan J. Banach, COL, IN Director,
School of Advanced
Military Studies

Robert F. Baumann, Ph.D. Director,
Graduate Degree
Programs

Disclaimer: Opinions, conclusions, and recommendations expressed or implied within are solely those of the author, and do not represent the views of the US Army School of Advanced Military Studies, the US Army Command and General Staff College, the United States Army, the Department of Defense, or any other US government agency. Cleared for public release: distribution unlimited.

Abstract

The Quebec Liberation Front (FLQ) as an Insurgency by LTC Alain Carrier, Canadian Military Engineers, 54 pages.

This monograph demonstrates that the FLQ was an insurgency through the verification of four characteristics common to five insurgency definitions. The Canadian government's initiatives and actions simply kept the FLQ insurgency from moving past the proto-insurgency stage.

Theorists like Bard E. O'Neill argue that governments hold the advantage while an insurgency remains only in the making. However, O'Neill also states that governments show complacency judging an insurgency at the proto-insurgency stage too small to warrant any immediate action. The Canadian government avoided that road and chose a more proactive approach to the FLQ.

The FLQ insurgency failed to grow past the proto-insurgency stage. Conditions created and actions taken by the government made organizing, self-sustainment, and growing, impossible for the FLQ. As a result, the FLQ insurgency failed.

Studying insurgencies at the proto-insurgency level reveals a lot about what an insurgency is and how a government can influence its growth. A study case like the FLQ further highlights how the odds of a government defeating an insurgency become higher, when the insurgency's identification and understanding happen early. However, the government must apply proactive actions and show the willingness to take some risks, including the consideration of an appropriate use of coercive countermeasures, to improve the odds in its favor.

Table of Contents

| | |
|---|-----|
| Table of Contents | iii |
| Section 1 – Introduction | 1 |
| Why the FLQ? | 7 |
| Methodology..... | 11 |
| Section 2 – Defining Insurgency | 13 |
| Literature Review | 14 |
| Insurgency Criterion | 19 |
| Section 3 – The FLQ (1963–1972)..... | 23 |
| Historical Root..... | 23 |
| Political, Social, and Economic Conditions (1958–1972)..... | 24 |
| FLQ’s Cause and Grievances | 28 |
| FLQ’s Protracted Conflict against the Canadian Government | 29 |
| FLQ’s Use of Violence, Subversion and Political Resources | 36 |
| FLQ’s Popular Support..... | 39 |
| Section 4 – Government’s Actions against the FLQ | 41 |
| Section 5 – Conclusion..... | 45 |
| Appendices | 48 |
| Appendix 1 – FLQ Map (1961–1965)..... | 48 |
| Appendix 2 - FLQ Map (1965–1969)..... | 49 |
| Appendix 3 - FLQ Map (1969–1972)..... | 50 |
| Appendix 4 – Quebec Political Parties and Movements | 51 |
| Bibliography | 52 |

Section 1 – Introduction

On October 10, 1970, Quebec's Vice Premier and Labour and Immigration provincial minister, Pierre Laporte, was tossing a football on his front lawn with a nephew in Montreal. Four men in a car drove by and kidnapped him. This was the last time he would see his family and house, as his assassination happened one week later on October 17, 1970. Laporte's kidnapping happened only five days after the Quebec Liberation Front (FLQ) had successfully kidnapped the British trade commissioner James Richard Cross from his house on October 5, 1970. The two FLQ kidnappings took place during the 1970 October Crisis. The extensive attention given to the crisis eventually over shadowed the rest of the FLQ's history.

The two kidnappings followed eight years of propaganda, demonstrations, attacks, robberies and bombings. While the FLQ carried out its clandestine operations, registered political parties and movements in the legitimate political arena simultaneously pursued Quebec's independence using propaganda, agitation, and demonstrations. This dual presence blurred both the political and insurgency environments, making it a harder task for the authorities to identify who the insurgents were, as many members of the *Ralliement pour l'indépendance nationale* (RIN) and other political movements led a double life.¹ Studying FLQ's story must therefore happen in conjunction with the political separatist movement, as linkages existed between both. Using propaganda and violent means, the FLQ sought to augment its population support, with the ultimate goal of achieving Quebec's secession from the Canadian Confederation. This monograph demonstrates that the FLQ was an insurgency. The government's initiatives and actions simply kept the FLQ from moving past a nascent or small stage of insurgency.²

¹ See Appendix 4 for the map of the Quebec provincial political parties and movements.

² In the context of this monograph, the government represents all the three levels of Canadian government. Therefore, the word government includes the federal government in Ottawa, the Quebec provincial government, and the municipal government. Most of FLQ's actions took place in the context of

The study of the FLQ as an insurgency requires first to establish a definition for the term insurgency as a start point for further discussion. Many definitions exist in literature. The definition of the United States' Joint Publication (JP) 3-24 *Counterinsurgency Operations* manual provides the start point. It defines an insurgency as "the organized use of subversion and violence by a group or movement that seeks to overthrow or force change of a governing authority. The use of subversion and violence makes insurgency distinct from the culturally accepted political process or culturally accepted nonviolent means of political protest. An insurgency is an internal conflict that focuses on the population."³ This definition presents a general understanding of what an insurgency is, without any relation to the FLQ history. It becomes relevant now to display evidence on the FLQ as a stage-setter to the case study.

As demonstrated by the two kidnappings, the FLQ presented a serious threat to the Canadian government's sovereignty in Quebec. However, the history of the FLQ did not begin with the events of the October Crisis.⁴ Yet, most of the events preceding the October Crisis are unknown, even to most Canadians. In a *Maclean's* article, Andrew Potter stated that for most Canadians under the age of forty, the story of the FLQ is just the compressed narrative of the

the greater area of the City of Montreal where English and French speaking communities lived side-by-side exposing the differences between the two.

³Department of Defense, Joint Publication 3-24 *Counterinsurgency Operations* (Washington, DC: Government Printing Office, October 5, 2009), I-1 and II-1. Subversion describes actions designed to undermine the military, economic, psychological, or political strength or morale of a governing authority. Insurgents may stage violent acts for their subversive impact, such as fomenting violent civil unrest, such as violent riots or strikes. Insurgents may also use nonviolent subversive efforts, such as political fronts, infiltration of government agencies, or nonviolent civil unrest (nonviolent strikes or peaceful public demonstrations). Subversion is most effective when consistently conducted over a long period. Insurgent use of propaganda, sabotage, and other means to influence audiences often seeks to undermine the legitimacy of the HN government and other counterinsurgent forces and increase support for the insurgency. Insurgents use violence, which may include guerrilla warfare, terrorism, and even conventional operations to erode the strength and numbers of counterinsurgent forces, weaken the HN government, undermine the HN government's legitimacy, and promote their influence.

⁴ FLQ maps included in Appendices 1, 2, and 3.

October Crisis.⁵ Very few people know that the FLQ became active in 1963. During the bitterly cold night of March 7, 1963, the FLQ simultaneously attacked three Canadian Army barracks with incendiary bombs. The targets were the Royal Montreal Regiment in Westmount, the Victoria Rifles on downtown Cathcart Street, and the Fourth (Chateauguay) Battalion of the Fusiliers du Mont-Royal on Cote-des-Neiges. On the walls, painted in red, were the initials 'FLQ'.⁶ These bombings marked the beginning of a protracted conflict that lasted from 1963 to 1972. Today, partisans still write press releases and post messages on the internet, trying to revive the FLQ. These more recent attempts faltered because the political and social climates changed, and the Quebec sovereignty movement does not enjoy the popular support it commanded in the days leading up to the October Crisis. Most notably, however, it is the absence of an extremist ideology, and the impatience leading to the use of terrorism as a method to speed the process of independence and self-governance, that made these attempts futile. The context of the 1960s and early 1970s distinguished itself by its uniqueness.

During the 1960s and early 1970s, the FLQ made continuous attempts to attract supporters using propaganda published in magazines, journals, and newsletters. The FLQ was not the only separatist movement in Quebec. Other separatist and socialist movements flourished alongside the registered political parties and the FLQ. Their presence gave the FLQ a source from which to draw strength, when it was the target of effective law enforcement. Because they had the same grievances that the movement defended and advocated, the FLQ's propaganda specifically

⁵ Andrew Potter, "The very very brief history of violence in Quebec," *Maclean's* 120, no. 7 (February 26, 2007): 10. Potter holds positions as a news editor at the Ottawa Citizen and a public affairs columnist with Maclean's magazine. He holds a PhD in Philosophy from the University of Toronto and worked as an assistant professor for three years at Trent University in Peterborough Ontario. He also did a year of post-doctoral work with a research centre at the *Université de Montréal* focusing on politics and technology.

⁶ Louis Fournier, *FLQ: Histoire d'un mouvement clandestin*, rev. ed. (Outremont, QC: Lanctôt Éditeur, 1998), 11.

targeted union workers and students. They also represented the majority of Quebec's French-speaking population. Externally, the FLQ sought and obtained some limited international support. In the international arena, the FLQ had links in Algeria through the National Liberation Front (FLN) and, with one of its activists, Gilles Pruneau, who chose exile in Algeria in 1963.⁷ In 1965, the Federal Bureau of Investigation (FBI) and the Royal Canadian Mounted Police (RCMP) established links between the FLQ and the U.S. Black Liberation Front. The FBI arrested a FLQ militant, Michèle Duclos, in Manhattan along with Robert Collier, Walter Bowe and Khaleel Sayyed from the Black Liberation Front.⁸ Conspiracy to execute numerous bombings targeting historical monuments in the United States, including the Statue of Liberty, was among the charges laid against the four individuals.⁹ Most notably, the Canadian government eventually provided the FLQ kidnappers safe passage to Cuba as part of the agreement upon James Cross' release on December 3, 1970. These few examples represent some the many that linked the FLQ with revolutionary movements and activists from Cuba, Algeria, France, and the United States.

The FLQ published three manifestos in April 1963, June 1970, and finally during the October Crisis in 1970. These manifestos outlined the grievances, the cause, and, to a point, the strategy of the FLQ. They are the founding documents of the FLQ's strategy and doctrine. Publishers included the contents of the three manifestos in newsletters as a way to disseminate

⁷ Robert Comeau, Daniel Cooper, and Pierre Vallières, *FLQ: un projet révolutionnaire. Lettres et écrits felquistes (1963-1982)* (Montmagny, QC: VLB éditeur, 1990), 28. Gilles Pruneau was a FLQ activist that was awaiting trial under freedom without bail. He took the opportunity to take refuge in France and subsequently in Algeria. In FLQ's *La Cognée* July 15 1964 edition, he published an article in which he voiced his surprise for the sense of approval that the Algiers' population was expressing for the liberation struggle that Quebec was undertaking.

⁸ Time, "New York: The Monumental Plot," *Time*, February 26, 1965, 28.

⁹ Fournier, 95-96. Following the assassination of Malcolm X, leader of the black radical movement, on February 15, 1965 in Harlem, The FBI arrests Duclos and the three members of the Black Liberation Front. Collier met Michèle Duclos in Montreal in January 1965 through Michèle Saulnier. He met Saulnier in Havana, Cuba during the summer of 1964. Saulnier also had relations with Cuban officials in Montreal and New York, and had links with the Algerian FLN dating to the time she worked for the National Tourist Office in Algiers.

FLQ propaganda. Through its information operations, the FLQ made significant efforts to increase its support. Similar efforts of the parallel movements like the *Front Républicain pour l'Indépendance* (FRI) and the *Groupe Révolution Québec* are examples of indirect support to the FLQ.¹⁰ Eventually, members of these two overt organizations joined the FLQ. For most of its existence, the FLQ maintained an activist wing and a political wing. The activist wing assumed many different forms such as the *Armée de libération du Québec* (ALQ) and the *Armée Révolutionnaire du Québec* (ARQ).¹¹ The ALQ and ARQ represented the FLQ's attempts to put together its own army. Effectively identified and suppressed by the government's law enforcement efforts, the activist wings that ensued focused more on the use of bombs, sabotage, and propaganda instead of building a small army. As the enhanced law enforcement efforts became more successful, the political wing, responsible for the coordination and the provision of guidance, became harder to replace. It resulted into less coordinated actions from the FLQ, but it made it tougher for law enforcement to knock the FLQ out.

The FLQ attempted to increase the internal support it enjoyed in order to achieve desired social and political changes. However, from the FLQ's perspective, registered provincial political parties promoting Quebec's independence did not gather membership and the electoral votes fast enough. The FLQ used this lethargy to justify their actions. All of these issues comprised the FLQ cause. Registered provincial political parties shared the FLQ cause but did not agree with the violent means it employed. The RIN was the only party that justified FLQ actions. RIN's leader, Pierre Bourgault, later reflected, "The violence, in itself, is hardly excusable but easily

¹⁰ The Republican Front for Independence (FRI) and the Quebec Revolution Group represent two unofficial translations.

¹¹ The Quebec Liberation Army (ALQ) and the Quebec Revolutionary Army (ARQ) represent two unofficial translations.

understandable.”¹² The history of the FLQ clearly indicates a protracted struggle between legitimately elected federal, provincial and municipal political parties and itself. The FLQ tried to fuel discontentment of Quebec’s French Canadian population by focusing on their common grievances.¹³ The grievances displayed little novelty and in fact had roots dating back to the seventeenth and eighteenth century colonization. The provincial and federal governments’ understanding of the grievances contributed to their success in keeping the FLQ from growing to the large-scale stage of insurgency.

The 2008 RAND Corporation study titled *War by other means: Building Complete and Balanced Capabilities for Counterinsurgency* provides a good description of the four possible stages of an-insurgency, including one similar to the nascent stage. These stages are part of the ‘Life-Cycle Model of Insurgency and COIN’ that defines both the size of an insurgency and the level of force required to fight it. The RAND study describes four stages for an insurgency:

The proto stage. This stage defines insurgents as barely noticeable, not having the potential to inspire insurgency, or dismissed as criminals or inconsequential crackpots. They are incapable of widespread or large-scale violence. The use of intelligence and law enforcement are preferred. The security force level comprises the police.

The small-scale stage. The movement survives the proto stage, attracts followers, and gains the capability of committing daring and destructive acts against the state with a view toward

¹² Jean-François Cardin, *Comprendre Octobre 1970 : Le FLQ, la Crise et le Syndicalisme* (Montreal : Éditions du Méridien, 1990), 67. Cardin cites Pierre Bourgault : “la violence ne s’excuse pas, mais elle s’explique drôlement.” Pierre Bourgault was RIN’s leader from 1964 to 1968.

¹³ A quick summary of FLQ’ grievances. Quebec is a French speaking colony under the rule of Anglo-Saxon capitalist imperialism. Eighty percent of Quebec’s economy is under the control of out of province interests. The French speakers provide the labor; the English speakers cash the profits. Unemployment is high and the government provides evidence of little improvements. Eighty percent of the province’s population is French speaking, yet English dominates all the sectors including but not restricted to workplace language usage, finance, provincial government, culture, and education. French Canadians are treated with contempt. The FLQ advocated the independence as the solution.

replacing it. The insurgency tries to shape political and economic conditions to develop popular support for the insurgency. Once insurgent violence exceeds police capabilities, requirement for use of military force may prove necessary.

The large-scale stage. The state fails to understand the danger of insurgency, to shape public sentiment against it, to address government shortcomings, or to use force effectively. At this stage, both the police and the military force become necessary.

The full-blown with external support stage. The insurgency exceeds the means of the state's security services, perhaps because of external support. The fateful question of external intervention arises.¹⁴

This monograph refers to these stages to correlate the size of the FLQ with the security force level required during its existence.

Why the FLQ?

Does a movement kidnap two high-ranking political officials just because, as Kevin Michael Grace put it, it is a movement of 'just a few young toughs' looking to make the front page of major newspapers around the globe?¹⁵ The quick answer is no. The FLQ wanted Quebec's independence, not the limelight.

This monograph asserts that the FLQ insurgency remained at the proto-insurgency stage, and that both the federal and provincial governments took efficient measures to hinder the FLQ's growth. The government remained vigilant and avoided complacency, gathered intelligence to

¹⁴ David Gompert and John Gordon IV, eds, *War by other means: Building Complete and Balanced Capabilities for Counterinsurgency* (Santa Monica, CA: RAND Corporation, 2008), 36-8. Although not included in the study, the monograph will also use nascent and incipient to refer to the proto-insurgency stage.

¹⁵ Kevin Michael Grace, "Just a few 'young toughs'," *Report/News magazine (Alberta Edition)* 28, Issue 3 (February 5, 2001): 13. Kevin Michael Grace is a Canadian journalist with a right-wing intellectual base. His avid critics targeted leftism, contemporary conservatism, and Canadian immigration policy. He opposed the 2003 invasion of Iraq.

understand better the nature of the insurgency, identified the root cause, and finally took the necessary countermeasures. In his recent *Small Wars Journal* article, Daniel G. Cox argues that the developing insurgency in Iran offers a real-world example of a government fighting a budding insurgency. Cox further uses the works of David Galula, Frank Kitson, and Bard E. O'Neill to state that the proper government course of action (COA) encompasses actions in three domains.¹⁶ First, the COA starts with intelligence gathering that promotes the recognition and the understanding of the type of insurgency. This first domain ties in with one of O'Neill's themes. O'Neill differentiates nine types of insurgencies by highlighting the fundamental differences in the goals they pursue. "Differentiating among goals has not only academic value but also some vital practical implications for those involved in insurgent conflicts."¹⁷ Identifying the insurgency's goals translates into implementing the right actions to counter it. Second, the COA advocates the use of coercive countermeasures. Cox states, "The national government must consistently apply pressure to a burgeoning insurgency in order that it does not gain its balance and secure a foothold."¹⁸ However, the use of coercion by the government represents a risk as it can promote popular support for the insurgency. Third and lastly, the COA suggests controlling the insurgency's message. Galula argues the importance of propaganda as critical to propagate the insurgency's cause especially in the early stages.¹⁹ Another way of controlling the message includes countering it with the government's own message. The Canadian and Quebec

¹⁶ Daniel G. Cox, "Unrest in Iran: A Test Case for Counterinsurgency Theory," *Small Wars Journal*, <http://smallwarsjournal.com/blog/journal/docs-temp/360-cox.pdf> (accessed March 15, 2010), 1-4.

¹⁷ Bard E. O'Neill, *Insurgency and Terrorism: From Revolution to Apocalypse*, 2nd ed. (Washington, DC: Potomac Books, 2005), 19. In all, O'Neill suggests nine types of insurgencies. They are anarchists, egalitarians, traditionalists, pluralists, apocalyptic-utopians, secessionists, reformists, preservationists, and commercialists. O'Neill is professor of international affairs at the National War College, Washington, DC, where he is also director of Middle East studies and director of studies of insurgency and revolution.

¹⁸ Cox, 6.

¹⁹ David Galula, *Counterinsurgency Warfare: Theory and Practice* (Westport, CT: Praeger Security International, 2006), 18-25.

governments acted in their struggle against the FLQ on these same domains. The government maintained a sufficiently accurate intelligence picture to topple the FLQ continually, used a good proportion of coercive countermeasures, and controlled the FLQ's message. The latter proved to represent the biggest challenge as it took them almost four years to take out *La Cognée*.²⁰ It still did not stop the propaganda since other newsletters, journals, and magazines continued after. The governments, however, enjoyed quick successes against the activist wings, and the leaders of the political wings. In addition to propaganda, the FLQ flirted with a revolutionary strategy that found its roots in Cuban and Maoist examples. At hindsight, the FLQ was never able to accomplish its strategy. The strategic concept faltered after law enforcement knocked out the FLQ political wing, making it impossible to execute its strategy. The FLQ insurgency grew differently than the Cuban and Maoist insurgencies because it took place within a capitalist, democratic and western modern environment. This kind of environment makes it difficult for an insurgency to rise and gain traction. This is especially true in Quebec where the majority of the French Canadian population would rather seek a democratic political solution to independence. As the FLQ found out during the October Crisis, a civilized, modern and democratic western civilization can only tolerate so much violence before withdrawing popular support for an insurgency. Creating fear produces different reactions in the West because of the presence of uncorrupted professional law enforcement capacity.

Little literature that defines or quickly describes the FLQ exists. O'Neill used the FLQ as an example of a secessionist insurgency. His claim needs further definition to gain real validity. A gap in the knowledge exists as far as defining the elements that made the FLQ an insurgency. The value of filling that gap with a single insurgency case study equates to one of a single country

²⁰ Fournier, 54. *La Cognée* was one of the most important and durable network of the FLQ. A good English translation is "The Hit".

study described in Todd Landman's *Issues and Methods in Comparative Politics*. It provides a contextual description and confirms theories.²¹ In the FLQ's case, it seeks to confirm that the movement remained at the proto-insurgency stage. Furthermore, the FLQ did not make any insurgency list. It failed to make it on the eighty-nine insurgencies identified in the RAND counterinsurgency study, titled *War by Other Means: Building Complete and Balanced for Counterinsurgency*, because the study limited itself mostly to insurgencies where at least 1000 people died, with at least a hundred on each side.²² However, this monograph can help inform a future study that focuses on proto-insurgencies.

The FLQ case study reiterates the importance of accurate and timely intelligence. Intelligence shapes situational awareness and understanding and limits the opportunities for a wicked problem to grow in complexity.²³ Rather, good intelligence helps make a problem complicated instead of complex.²⁴ A better-defined problem also takes possible COAs off the table and prevents the consideration of an inappropriately harsh solution. The FLQ adapted, willingly or not, as any complex adaptive system does. Intelligence also enables the identification of an insurgency before it grows into the small and large insurgency stages previously described. If you accomplish early identification, it is easier to eradicate and root out the insurgency.

²¹ Todd Landman, *Issues and Methods in Comparative Politics*, 3rd ed. (New York: Routledge, 2008), 28.

²² Gombert and Gordon IV, 373.

²³ Horst W.J. Rittel and Melvin M. Webber, "Dilemmas in a General Theory of Planning," *Policy Sciences* 4 (1973): 160. The authors define wicked problems by contrasting them with the problems that scientists and engineers have usually focused on. "These problems are definable and separable and may have solutions that are findable. Wicked problems are ill defined, and they rely upon elusive political judgment for resolution." The article identifies ten distinguishing properties of wicked or planning-type problems.

²⁴ Axelrod and Cohen, 15. "Complexity indicates that the system consists of parts which interact in ways that heavily influence the probabilities of later events. Complexity often results in features, called **emergent properties**, which are properties of the system that the separate parts do not have. To distinguish systems that do have a lot of "moving parts" but may not be complex, we will use the term **complicated**." Emphasis in original text. Decomposition of complicated systems into smaller sub-systems is possible because the sub-systems do not interact.

Lastly, looking beyond the study of the past classical insurgency cases has its importance. Coalition forces currently involved in Afghanistan and Iraq did not correctly identify and recognize the threat of an insurgency. It prevented them from taking early actions to prevent the insurgency's growth. The profession of arms and theorists tend to disregard protracted conflicts with few casualties, during which a legitimate armed force is not heavily involved, and the insurgency is unsuccessful. In the FLQ's case, the verdict often looked like a quick dismissal as something other than an insurgency. This misclassification limits the expansion of insurgency studies. O'Neill states that any government, regardless of type, has the advantage during the embryonic stages of an insurgency due to a higher level of political organization, more mature institutions, and control over well-organized means of coercion.²⁵ Similar to today's Iranian example, the federal and provincial governments struck the FLQ during its incipient stage. The FLQ presents a good vehicle for understanding how to identify an insurgency during the proto-insurgency stage when it stares at you, from any perspective, not only a Canadian or North American one. This study bears relevancy for professional military officers, neophytes and counterinsurgency theorists, and historians because it exemplifies the strategy of attacking the insurgency before it reaches the small or the large-scale stages.

Methodology

This monograph is a single descriptive case study. Section 2 aims at providing a criterion to measure the evidence of the FLQ as an insurgency. The section starts with a review covering how existing literature describes the FLQ and how these descriptions relate to the one of an insurgency. The development of the criterion to determine if the FLQ possesses the characteristics of an insurgency follows, using the JP 3-24 insurgency definition as a start. The

²⁵ O'Neill, 155.

criterion achieves both relevancy and absence of bias through the consideration of characteristics of four other insurgency definitions covering military doctrine, theory and current practice. The other definitions come from B-GL-323-004/FP-003 Canadian Forces' publication, *Counter-Insurgency Operations*, David Galula's *Counterinsurgency Warfare: Theory and Practice*, Bard O'Neill's *Insurgency and Terrorism: From Revolution to Apocalypse*, and RAND's counterinsurgency study titled *War by Other Means: Building Complete and Balanced for Counterinsurgency* published in 2008. By looking at similarities of characteristics of these four definitions with the one from JP 3-24, the section selects four insurgency characteristics to form the criterion.

With the definition of the criterion completed, Section 3 follows with the autopsy of the FLQ to demonstrate how it espouses the four characteristics of an insurgency. The section starts with a description of the historical roots of the French Canadians, and the political, social and economic context of the 1958 to 1972 period. Evidence from primary sources written by some of FLQ's most influential and key members of its political wings, as well as scholars, show that the movement had many reference documents from which to base and disseminate its ideology, strategy and aims. The study of additional artifacts, including a published report of the RCMP intelligence section,²⁶ demonstrates that the FLQ involved more than just the acts of a few frustrated and angry French Canadians. These documents display evidence of a movement trying to mobilize support to rise against the legitimate Canadian government. The FLQ's hierarchy failed to remain a constant feature throughout its existence, partly due to the successful regular

²⁶ The RCMP is the federal law enforcement agency. Its name is *Gendarmerie Royale du Canada* (GRC) in French. Its Security and Intelligence Section's involvement was responsible for the successes of the enhanced law enforcement force. Quebec provincial police is *La Sureté du Québec* (SQ). People refer to it as the Quebec Provincial Police (QPP). No official translation exists. At the municipal level, every major city has its police force. For example, the City of Montreal has its own. For cities and towns that are not big enough to have their own, *La Sureté du Québec* has jurisdiction. It serves exclusively 1038 cities, municipalities and towns, spreaded across 87 regional county municipalities (RCM) and equivalent territories in an RCM.

and antiterrorist work by the police.²⁷ This autopsy of the FLQ's writings helps explain its definition as an insurgency, even though many contemporary writers and journalists published documents describing the FLQ's actions as isolated acts of terrorism or crimes. The Canadian government systematically refused to recognize the arrested and convicted members of the FLQ as political prisoners to avoid giving it recognition and augment any sort of legitimacy it had.

Section 4 then proceeds with the exhibit of the government's actions that quelled the FLQ. The section seeks to confirm that the federal and provincial governments' initiatives and actions kept the FLQ from moving past the proto stage of an insurgency. Section 4 further highlights the relevance of the government COA in accordance with Cox's *Small Wars Journal* article.

Existing literature about classical insurgencies forms an abundant body of knowledge. The FLQ case study helps expand the existing knowledge, and the definition of an insurgency through the study of an insurgency at the proto-insurgency stage.

Section 2 – Defining Insurgency

Contrary to the definition of the word insurgency, the description of the FLQ escaped scrutiny. The word insurgency possesses as many definitions as its number of conflicts. However, all insurgency definitions offer similar themes with particulars emphasized according to the author's background. Authors, such as Roger Trinquier, stated the meaning of insurgency by defining its counterpart, counterinsurgency warfare, as "a new form of warfare called *modern warfare*."²⁸ Other authors went down the same path and called it at times either *subversive*

²⁷ Potter, 10. The author however does not point out that the activation and/or creation of anti-terrorist sections was part of the actions taken to deal with the FLQ. It was not the work of the normal police even though municipal and provincial police helped.

²⁸ Roger Trinquier, *Modern Warfare A French View of Counterinsurgency*, trans. Daniel Lee (1964; repr., Fort Leavenworth, KS: Combat Studies Institute, 1985), 6-7.

warfare,²⁹ or *revolutionary warfare*³⁰. Similarly, the definition of the FLQ resulted from a study of related topics such as the 1970 October Crisis, the application of the War Measures Act (WMA), and the relation between the FLQ and the media, only to name three. Very little literature defines the FLQ head on. To demonstrate this point, a literature review follows.

Literature Review

Bard O'Neill represents one of few authors who defined the FLQ as a secessionist insurgency. The FLQ can also serve as a loose fitting example of his egalitarian type. He describes the FLQ in Canada as one of the examples, in Europe and North America, of secessionists seeking to form their own nation-state.³¹ His statement does not answer why the FLQ is an insurgency. This forms the gap that this monograph fills. O'Neill writes, "Insurgency may be defined as a struggle between a non-ruling group and the ruling authorities in which the non-ruling group consciously uses *political resources* (e.g. organizational expertise, propaganda, and demonstrations) and *violence* to destroy, reformulate, or sustain the basis of legitimacy of one or more aspects of politics."³² Consideration of the characteristics of this definition takes place

²⁹ Steven P. Basilici and Jeremy Simmons, *Transformation: A Bold Case for Unconventional Warfare* (Monterey, CA: Naval Postgraduate School, June 2004), 29. The authors state that the literature on guerrilla and subversive war at the micro level complicates its understanding. The definitions of guerrilla warfare, subversive warfare, or unconventional warfare (all of which are merely styles of warfare) serve as a way to characterize the environmental setting as well. Even when the environment's description is correct, the presence of a surplus of terms remains.

³⁰ John Morgan Dederer, *Making Bricks without Straw: Nathanael Greene's Southern Campaign and Mao Tse-Tung's Mobile War* (Manhattan, KS: Sunflower University Press, 1983), 8. Mao divided revolutionary war into three strategic stages: guerilla warfare, mobile war, and the strategic offensive.

³¹ O'Neill, 24-25. According to the author, secessionists renounce and seek to withdraw from the political community (state) of which they are formally a part. Some secessionists seek either to form their own nation-state or to join another. Bard O'Neill also writes that egalitarian insurgent movements, which came to power, normally established authoritarian, repressive, and elitist political systems. He defines the egalitarian type as seeking to impose a new system based on the ultimate value of distributional equality and centrally controlled structure designed to mobilize the people and radically transform the social structure within an existing political community.

³² *Ibid.*, 15. Emphasis in original document. The author further states, "The major aspects of politics may be identified as the political community, the political system, the authorities, and policies."

later to establish the criterion. O'Neill's correctness lies in his identification of the movement in Quebec seeking to separate the province from the Canadian Confederation. Quebec's independence movement finds its roots in the creation of legitimate political parties and groups at the provincial, and later on, at the federal level, as well as some radical and clandestine movements like the FLQ.³³

Louis Fournier described it, as an underground movement.³⁴ According to Fournier, the history of the FLQ, as an underground movement, will always remain mysterious and incomplete because, by definition, it is a secret story.³⁵ The Montreal police's antiterrorist section, the Combined Antiterrorist Squad (CATS), and the RCMP never managed to map out the FLQ's organization with confidence and completeness. The essence of FLQ's inherent complexity arose from its loose way of organizing itself, its links with other independence activists groups and a registered political party (RIN), and its external links. The numerous changes throughout its existence added to its complexity.³⁶ Fournier's perspective comes from a journalist that lived the October Crisis and suffered the consequences of his initiatives. With the majority of insurgencies

³³ The FLQ was always present but other independence movements also existed. Most of these movements fed the FLQ making it possible for it to survive even though enhanced law enforcement was successful in dismantling it many times without totally eradicating it. See Appendix 1,2 and 3 for Quebec political parties promoting independence that intertwine with the FLQ.

³⁴ Fournier, 300. Louis Fournier was a journalist for fifteen years. He was the first to read the third FLQ manifesto while employed by the CKAC radio station. His reading aired on October 7, 1970, two days after Cross' kidnapping. The reading took place with the station's consent but without the government's. Since this was one of FLQ's demands following the first kidnapping, the authorities arrested him without a warrant and detained him for questioning for more than four hours on October 9, 1970.

³⁵ Ibid., 8. Most insurgencies are underground movements. Citation of Fournier's description of the FLQ is to highlight the lack of definition or description of the FLQ. Although many books, articles and studies about the FLQ exist, a lot about the movement remains unknown or incomplete.

³⁶ The Montreal antiterrorist section and the CATS were successful in knocking the FLQ leaders and founders but were never able, until the October Crisis, to eradicate the FLQ to the root, as members from parallel movements went on to join the FLQ. The situation already complex was growing in complexity with every law enforcement success as the FLQ system adapted. In 1968, all the separatist political parties merged as the *Parti Québécois* under the leadership of René Lévesque. Some of the activist organizations eventually did the same under the FLQ. Once insurgent violence exceeds police capabilities, requirement for use of military force may arise.

including some sort of an underground element, the demonstration of the FLQ as an insurgency includes its consideration as an underground movement. Intuitively, not every underground movement uses subversion and violence to overthrow or force change of a governing authority but most insurgencies have an underground movement of some sort. However, to close the review of Fournier's characterization of the FLQ, the movement did gain enough support to create massive gatherings that threatened the security and the stability, especially during the October Crisis.

Some sources defined the FLQ as an insurrection. In an article published in *Queen's Quarterly*, Reg Whitaker discusses the FLQ as an apprehended insurrection.³⁷ Whitaker does not define insurrection. Webster's Everyday Thesaurus lists insurrection as synonymous with the words revolt, rebellion, revolution, insurgence, mutiny, riot, rising, uprising, and outbreak. Canadian and United States military publications, thus define an insurrection through defining insurgency. For the purpose of this monograph, both insurrection and insurgency focus on overthrowing or forcing change of a governing authority.

Finally, numerous authors defined the FLQ as a terrorist organization. Stéphane Leman-Langlois and Jean-Paul Brodeur represent two of them. In their article, they break the counterterrorism fight in Canada in two distinct periods. They refer to the FLQ, 1963 to 1973 period, as the conventional or old terrorism, and everything following as the new terrorism period. The main characteristics of the conventional terrorism are the claim of responsibility, or at least an explanation of the deed, the derivation of a maximum effect from minimal violence through communiqués that spelled out the meaning of the violence, communication through the

³⁷ Reg Whitaker, "Apprehended Insurrection? RCMP Intelligence and the October Crisis," *Queen's Quarterly* 100/2 (Summer 1993): 383. Canadian Prime Minister Pierre Trudeau enacted the state of apprehended insurrection to proclaim the War Measures Act (WMA). The proclamation followed the request by Quebec Premier Robert Bourassa and Montreal Mayor Jean Drapeau.

written word instead of images, and the majority of politically motivated violence instead of religiously motivated. In opposition, new terrorism's characteristics are the absence of claim, maximum violence without any discursive explanation, communication through images of destruction, and the religious root to its violence.³⁸ Leman-Langlois and Brodeur offer a good description of the FLQ as a terrorist organization but do not go further. However, JP 3-24 does state that the disparity of means drives insurgents to use subversion, guerrilla warfare, and terrorism, in the face of capable counterinsurgent forces.³⁹ What an insurgency is, and its relation with terrorism requires definition and clarification to understand the difference between defining the FLQ as strictly a terrorist organization, or as an insurgency using terrorism.

Depiction as a terrorist organization arises as the most commonly used FLQ definition in the literature. Why the FLQ escaped definition as an insurgency is a product of the prominent narrative of the 1960s and 1970s. John Shy and Thomas B. Collier define terrorism as attacking nonmilitary targets,⁴⁰ or for attacks using surprise and unusual methods.⁴¹ Other authors like Bruce Hoffman and Paul R. Pillar present more detailed definitions. This sub-section seeks to define terrorism's relation with insurgency.

Bruce Hoffman defines terrorism as the deliberate creation and exploitation of fear through violence or the threat of violence in the pursuit of political change.⁴² He further states

³⁸ Stéphane Leman-Langlois and Jean-Paul Brodeur, "Terrorism Old and New: Counterterrorism in Canada," *Police Practice and Research* 6, no.2 (May 2005), 129-134. There are other differences between old and new terrorism.

³⁹ JP 3-24, I-1.

⁴⁰ The FLQ targeted military installations because they are part of the federal establishment. They did not attack the military forces themselves.

⁴¹ John Shy and Thomas W. Collier, "Revolutionary War" in *Makers of Modern Strategy: from Machiavelli to the Nuclear Age*, ed. Peter Paret (Princeton, NJ: Princeton University Press, 1986), 821.

⁴² Bruce Hoffman, *Inside Terrorism*, rev. and expanded ed. (New York, NY: (Columbia University Press, 2006), 40-41. The author also makes distinctions between terrorism, guerilla warfare and insurgency stating fundamental differences between the three. They often employ the same tactics and wear

“terrorists do not function in the open as armed units, generally do not attempt to seize or hold territory, deliberately avoid engaging enemy military forces in combat, are constrained both numerically and logistically from undertaking concerted mass political mobilization efforts, and exercise no direct control or governance over a populace at either the local or national level.”⁴³ His definition identifies many common elements between insurgency and terrorism. However, he does not establish one as a possible subset of the other.

On the other hand, Paul R. Pillar’s definition presents many characteristics of interest. He defines terrorism as premeditated, politically motivated violence perpetrated against noncombatant targets by sub national groups or clandestine agents, usually intended to influence an audience.⁴⁴ He nuances or emphasizes all the elements included in Bruce Hoffman’s definition. An inference about the subordination between insurgency and terrorism appears when he ascribes terrorism as a method rather than a set of adversaries or the causes they pursue. It represent a problem of what people, groups, or states do, rather than who they are or what they are trying to achieve.⁴⁵ Terrorism is therefore a method or a means that insurgents may use. The FLQ used it a lot. The employment of terrorism by an insurgency can serve many purposes. The

neither uniform nor identifying insignia. Guerilla and insurgency refer to a larger group of armed individuals, who operate as a military unit ,attack enemy military forces, and seize and hold territory (even if only ephemerally during daylight hours), while also exercising some form of sovereignty or control over a defined geographical area and its population. In addition, insurgencies typically involve coordinated informational (e.g. propaganda) and psychological warfare efforts designed to mobilize popular support in a struggle against an established national government, imperialist power, or foreign occupying force. However, the insurgents’ strategy and operations transcend hit-and-run attacks.

⁴³ Hoffman, 35. Author uses the Central Intelligence Agency’s *Guide to the analysis of Insurgency*.

⁴⁴ Paul R. Pillar, *Terrorism and U.S. Foreign Policy* (Washington, DC: Brookings Institution Press, 2003), 13. Pillar nuances Hoffman by using premeditation vice deliberation. They are synonymous. Hoffman states that terrorism avoids engaging enemy military combat forces when Pillar talks about violence perpetrated against noncombatant targets.

⁴⁵ *Ibid.*, 18. Paul R. Pillar does not talk about what defines people. Ideology, beliefs and the experience of living define people. It forms their narrative. Ideology directs goals and actions. Actions can be of a terrorist nature.

problem presented to a government by an insurgency might require some accelerant to fuel the fire of population support. As David Galula wrote, “Terrorism may be a quick means of producing this effect. If the problem is merely latent, the first task of the insurgent is to make it acute by raising the political consciousness of the masses.”⁴⁶

Insurgency Criterion

The monograph’s introduction already presented a start point for the definition of insurgency. For this purpose, JP 3-24’s definition symbolizes the foundation for the determination of the criterion. The criterion includes the four most common characteristics found in the five-insurgency definitions under consideration. With each insurgency definition being short, the exploration includes characteristics complementing each one. By going through this process, the aim is to achieve two criterion’s attributes: relevancy and absence of bias.

The choice of insurgency definitions used a wide variety of sources as the first lens to reach relevance. Definitions from JP 3-24 and B-GL-323-004/FP-003 Canadian Forces’ publication, *Counter-Insurgency Operations* offer a military doctrine perspective. David Galula’s *Counterinsurgency Warfare: Theory and Practice*, and Bard O’Neill’s *Insurgency and Terrorism: From Revolution to Apocalypse* present two theorists’ views. Finally, RAND’s counterinsurgency study *War by Other Means: Building Complete and Balanced for Counterinsurgency* gives a definition in the context of the conflicts in Iraq and Afghanistan. Even though, the FLQ protracted struggle with the Canadian government occurred between 1963 and 1972, its study takes place through the context of a diverse range of contemporary to recent definitions. Secondly, the criterion must show an absence of bias. To demonstrate an absence of bias, the author deliberately chose five recent insurgency definitions. One can still argue that

⁴⁶ Galula, 15.

choosing five definitions still demonstrates some sort of bias. However, since four common characteristics between these five definitions form the criterion, the latter bears as much as an absence of bias that one individual hopes to achieve.

First, JP 3-24's definition of insurgency presented in the introduction confers the following characteristics: the presence of a governing authority and a group or movement that challenges the government, the description as an internal conflict focusing on the population, and the group's desire to overthrow or force change of the governing using subversion and violence. Further to the elements included in the definition, JP 3-24 adds that the insurgency's level of organization ranges from a highly organized single movement to a loose coalition of poorly organized groups. The insurgency advocates one or multiple causes, an ideology and a narrative.⁴⁷ Finally, JP 3-24 presents active or passive internal support to the insurgency as vital, and external support, whether political, psychological, or material, as a welcomed complement.⁴⁸

The second military doctrine definition found in B-GL-323-004/FP-003 Canadian Forces' publication, *Counter-Insurgency Operations* defines insurgency "as a competition of will (or a struggle) involving at least one non-state movement using means that include violence against an established authority to achieve political change."⁴⁹ This definition emphasizes all the characteristics of JP 3-24 but the use of subversion, and the description as an internal conflict focusing on the population. The publication does add the presence of a political aim and legitimate grievances as the core of the insurgency's narrative. The narrative provides the

⁴⁷ Hayden White, *The Content of the Form* (Baltimore, MD: The Johns Hopkins University Press, 1987), 2. The author posits "the idea that narrative should be considered less as a form of representation than as a manner of speaking about events, whether real or imaginary." A narrative is how a given actor, agent or organization sees and defines reality through their lenses.

⁴⁸ JP 3-24, II-1 to II-28.

⁴⁹ National Defence, B-GL-323-004/FP-003 *Counter-Insurgency Operations* (Kingston, ON: Army Publishing Office, 2008), 1-2. Irregular activities are "behaviour that attempts to effect or prevent change through the illegal use, or threat, of violence, conducted by ideologically or criminally motivated non-regular forces, groups or individuals, as a challenge to authority."

insurgency with legitimacy. Finally, the insurgent organization comprises of many elements: strategic or group leaders, an underground, guerillas, a political and ideological cadre, and the auxiliaries (support element).

Third, the sub-section considers O'Neill's insurgency definition outlined in Section 1. O'Neill includes the characteristics of the Canadian Forces' definition. More precisely, he includes the protagonists (ruling and non-ruling) and describes their confrontation as a struggle. O'Neill also states the use of violence by the non-ruling group as part of the means to its disposition but he adds the political resources (organizational expertise, propaganda, and demonstrations). According to O'Neill, the array of means serves to destroy, reformulate, or sustain the basis of legitimacy of one or more aspects of politics of the ruling government.⁵⁰

Fourth, David Galula defines insurgency "as a civil war and a *protracted struggle* conducted methodically, step by step, in order to attain specific intermediate objectives leading finally to the overthrow of the existing order."⁵¹ Again, all the characteristics of Galula's definition exist in the first three already considered. However, following its definition, he describes the internal population support as the ultimate prize, and the external support as of importance. Galula also points out the necessity of a cause to attract support. He postulates that the best cause for the insurgent's purpose is one that attracts the largest number of supporters, while repelling the minimum.⁵² His definition highlights the necessity of internal support, while external support, moral, political, technical, financial, and military, represents something of lesser importance. The timely choice of a cause helps the insurgency to increase the internal support.

Fifth and last, RAND's 2008 counterinsurgency study states, "Insurgencies, by definition, seek to replace an existing order with one that conforms to their political, economic, ideological,

⁵⁰ O'Neill, 15-9. See note 32 for the description of the aspects of politics.

⁵¹ Galula, 2. Emphasis in original document.

⁵² Ibid., 13.

or religious vision. They are organized movements to overthrow existing ruling structures by a combination of force and popular appeal.”⁵³ The RAND definition presents characteristics of the first four. However, just as both the JP 3-24 and O’Neill definitions, the study points out the importance of the popular support. The RAND study furthers its definition stating that insurgencies have grievances of political, religious, ethnic, or economic nature. The grievances have some resonance in the population.⁵⁴

The analysis of the common characteristics of the five definitions proposes the following four elements to form the criterion. First, an insurgency addresses grievances nesting within its cause. The grievances have some resonance in the population, giving them legitimacy. Second, an insurgency represents a protracted conflict between a governing authority, and a group or movement seeking to overthrow or force political change of the governing authority. Third, an insurgency uses a combination of violence, subversion, and political resources (organizational expertise, propaganda, and demonstrations). Fourth, an insurgency seeks the popular support (internal, active or latent, is necessary, and external is desirable and augments the insurgency’s odds for success).

With the criterion completed, the FLQ case study addresses each of its four characteristics to demonstrate that it represented an insurgency. To complement the brief context laid during the introduction, the case study requires setting the historical root, and the political, social and economical conditions between 1958 and 1972. This completed foundation facilitates the understanding of the evidence.

⁵³Gompert and Gordon IV, 23; Ibid., xxix.

⁵⁴ Ibid.

Section 3 – The FLQ (1963–1972)

Historical Root

To grasp the root of the French Canadians grievances, the colonial period provides the starting point. Samuel de Champlain established the first permanent European settlements at Port Royal in 1605, and in Quebec in 1608.⁵⁵ Concurrently, the English established fishing outposts in Newfoundland around 1610 and founded 13 colonies in the south.⁵⁶ A series of four inter-colonial wars between France and England erupted between 1689 and 1763. In 1763, following the Seven Years' War, France ceded the northern portions of New France to the British, retaining fishing rights with the St-Pierre and Miquelon islands. The Royal Proclamation of 1763 renamed New France, Quebec. English law and courts replaced the French system, except for laws about marriage and property. The proclamation permitted the use of the French language and the practice of the Catholic religion, but Catholics could not work for the government. The government introduced English and promoted the Protestant religion as the official language and religion of the colony.⁵⁷ The increase of British settlers never materialized but the provisions of the Royal Proclamation remained. These provisions from 250 years ago are at the root of the French Canadians grievances. With the rising discontentment of the French Canadians, the British government passed the Quebec Act of 1774. The Act reversed the idea of establishing uniformity based on English institutions in the North American English colonies. Quebec received a distinctive treatment. French Canadians now enjoyed the freedom to use their language, customs and Catholic religion. The Act also granted them most of the old French civil laws including the

⁵⁵ Samuel de Champlain followed Jacques Cartier who discovered New France (*Nouvelle-France* in French) in 1534. The discovery is from a European perspective, as Native people were already present. Port Royal is now Annapolis Royal in the province of Nova Scotia.

⁵⁶ According to history, the Englishman John Cabot first explored Canada's Atlantic coast in 1497

⁵⁷ The British government wanted to attract British settlers in Canada, and to ensure the usage of English language and laws, and the practice of the Protestant religion.

seigneurial tenure of land, ensured the rights of the clergy to collect tithes, and offered the people an oath of allegiance that contained no insulting religious clause. Quebec reverted mostly to the traditions of the French regime including rule by the governor and appointed council rather than by an elected assembly. The Quebec Act guaranteed the primacy of the church as well as French property and civil law. The Act's provisions represent the seeds of difference and cultural diversity. The French Canadians' grievances grew during eleven years following the Royal Proclamation. This decade of waiting for recognition left an indelible mark. The British government applied the modifications in good faith based on the majority presence of French Canadians. While the Quebec Act made the French Canadians happy, it met discontentment from a small group of English settlers. As Canadian history shows, the country expanded to ten provinces and three territories to reflect today's borders. The majority of French Canadians stayed in Quebec. The rest of Canada received more English speakers and demographics changed to reflect an English speaking majority.⁵⁸ The province of Quebec received special attention by virtue of an imperial act of parliament. Through time, this created two second-order effects. First, English speaking majority started to question the relevance of special provisions to the French Canadians, since they are no longer more numerous. Second, it brought the Quebec's concept of distinct society,⁵⁹ which is one of the tenets of their later independence movement.

Political, Social, and Economic Conditions (1958–1972)

Canadians elected two consecutive Progressive Conservative governments between 1958 and 1963. Their leader, John Diefenbaker, pursued a one-nation policy promoting equality for all Canadians. Diefenbaker's unwillingness to make any concessions to Quebec's French Canadians

⁵⁸ French speakers still account for eighty percent of Quebec's population according to the most recent 2006 Census, but only twenty-three percent of the total Canadian population.

⁵⁹ The concept of a distinct society states that Quebec has a different language, culture and institutions.

resulted in few Quebec ministers appointed to his Cabinet. These two facts led to declining support for his party.⁶⁰ Two minority Liberal governments, led by Lester B. Pearson, followed from 1963 to 1968. Prime Minister Pearson instituted equal rights for women and bilingualism, making French the second official language. His relations with Quebec's Premier Jean Lesage led to cooperation while dealing with the rise of the Quebec separatist movement. The Liberal party stayed in power for three more terms until 1979, with Pierre Elliott Trudeau succeeding Lester B. Pearson. Trudeau implemented bilingualism and invoked the WMA in October 1970, in response to an apprehended insurrection in Quebec. Trudeau also defended the new universal healthcare and the regional development programs. In summary, the separatist movements evolved within an environment of federal minority governments from 1962 to 1968. Diefenbaker's national policy helped fuel Quebec's discontentment while Pearson and Trudeau managed to diminish it with the adoption of bilingualism. With the majority of French Canadians living in Quebec, the recognition of French as an official language further proved Quebec's concept of a distinct society.

At the provincial level, Quebecers elected Maurice Duplessis' *Union Nationale* from 1944 to 1959.⁶¹ His critics still refer to his four consecutive terms as the 'Great Darkness' because of his conservative policies.⁶² Duplessis used corruption and patronage to keep the Quebec Liberal Party's (PLQ) opposition weak.⁶³ Duplessis' policies favored rural areas over city

⁶⁰ The Progressive Conservatives went from a majority party in 1958-62 to a minority party in 1962-63. Canadian Parliament contains 308 elected Members. Of this number, Quebec has 75 and Ontario has 106. With the breakdown of seats based on the population, discontentment in these two provinces has massive effects on the next election.

⁶¹ National Union in English. See Appendix 4 for Map of Quebec's Provincial politics.

⁶² *La Grande noirceur* in French.

⁶³ Canadian Broadcasting Centre, "Duplessis Orphans get \$26M from Quebec," CBC News, <http://www.cbc.ca/canada/montreal/story/2006/12/21/qc-duplessisorphans.html> (accessed March 7, 2010). The Duplessis orphans case is an example. Duplessis developed a scheme to obtain federal funding for mental institutions. Mental institutions were the Federal government's responsibility, when orphanages and

development, championed provincial rights, anti-communism, and opposed the trade unions. Economically, Quebec suffered from under development and a lack of foreign development. Jean Lesage's PLQ succeeded the *Union Nationale* from 1960 to 1966. Quebec entered the Quiet Revolution.⁶⁴ The creation of the Ministry of Education, and the new health care system moved the society from the traditional Catholic Church domination to a more modern independent life. Major reforms made in the public sector, including legalization and promotion of workers' unions improved working conditions.⁶⁵ The nationalization of hydro-electricity and the creation of public companies to exploit Quebec's vast natural resources brought an expansion and innovation to the economy.⁶⁶ In 1966, the National Union came back to power under the leadership of Daniel Johnson. In Quebec, Johnson recognized the possibility of independence for Canada from the British Crown. He advocated that if English Canadians did not want independence from the United Kingdom, Quebec could seek it alone.⁶⁷ The economic expansion phase soon stopped and

schools were the province's responsibility. The orphanages, filled with thousands of children abandoned by single mothers, were the theatre of harsh treatments and sexual abuse by the psychiatrists, priests, nuns and administrators. As two examples, Duplessis proclaimed that the building of a needed bridge at Trois-Rivières would not take place should they elect a Liberal MNA. He kept his word while the opposition held the seat. A historically Liberal rural district had its roads unpaved, making it difficult for commerce and transportation. In 1956, the residents elected the National Union as the only way to get new roads constructed. National Union won 48 of 91 seats for its first term from 1944 to 1948, 82 of 92 seats for its second from 1948 to 1952, 68 of 92 seats for its third, and 72 of 93 seats for its fourth and last. Duplessis enjoyed the active support of the Roman Catholic Church in its political campaigns employing slogans like "The sky/heaven is blue (National Union's color), Hell is red (PLQ's color)". *Le ciel est bleu, l'enfer est rouge* in French.

⁶⁴ The Quiet Revolution sought to change the traditional domination of Quebec's economy by English-speaking Canadians, and the traditional domination of education and health care by the Catholic Church. The government of Quebec took the lead in education and health care. Education became mandatory until the age of sixteen. The government created a network of public schools at the high school and college levels. *La révolution tranquille*, in French.

⁶⁵ The creation of unions in the public sector included the grant of the workers' right to strike.

⁶⁶ René Levesque, the natural resources minister under the Liberal government of Jean Lesage, put these reforms in place. Lévesque later became the leader of the *Parti Québécois*.

⁶⁷ Daniel Johnson died in office September 26, 1968. His successor Jean-Jacques Bertrand was a federalist. His defeat to the Liberals in the 1970 election caused members of the *Union Nationale* to leave the Party and join the *Parti Québécois*.

led to a recession that started in 1966-67 and continued until 1970. Provincial unemployment rose from 4.7 percent in 1966 to an astounding 7.7 percent in 1970. Unemployment hit young adults the hardest with 91 percent of the newly unemployed twenty-five and less.⁶⁸ The PLQ returned to power in 1970 with Robert Bourassa as the Premier. Bourassa and Montreal Mayor Jean Drapeau requested Prime Minister Trudeau's invocation of the WMA after the Pierre Laporte kidnapping. Bourassa and Trudeau often clashed over issues of federal-provincial issues and Quebec nationalism.

The consideration of the political, social, and economic between 1958 and 1972 reveal many second and third order effects. The Diefenbaker approach of no concessions to Quebec raised discontent in the province and contributed to the rise of nationalism and difference. The following liberal federal governments' adoption of bilingualism reinforced the difference concept. The effects of the Quiet Revolution brought social and economic changes promoting the Quebecers' belief that they could be a nation. A growing feeling that Quebec should decide of its destiny without anybody's consent became prevalent. Even a right wing party such as the *Union Nationale* mentioned the validity of the nation option for Quebec.

It is in that context of social change, economic autonomy, creation of unions to protect workers, and independence that separatist organizations at the provincial level came into existence. In 1957, the *Alliance Laurentienne* represented the earliest separatist political movement. The Alliance, a right wing orientated organization, dissolved in 1962 without achieving the political party status. Part of his membership followed a more leftist orientation. The group parted with the Alliance and gave birth in 1960, to a radical leftist party, the

⁶⁸ Cardin, 67.

Ralliement pour l'Indépendance Nationale (RIN).⁶⁹ The RIN became the first separatist political party in 1963.⁷⁰ A part of his membership, disillusioned with the slowness and difficulty of the legitimate political approach to the Quebec independence, founded the FLQ in February 1963.⁷¹ With the context set, the section proceeds to the study of the FLQ as an insurgency through the four characteristics of the criterion.

FLQ's Cause and Grievances

The first manifesto, broadcasted April 16, 1963, provides FLQ's cause and their grievances. The writing of the manifesto happened in a period of decolonization around the world. Algeria and Cuba expressed the two most prominent examples of successful revolutions. Through the Cuban and Algerian models, the FLQ found the roots of its revolution.

The FLQ's cause carried a single message: INDEPENDENCE OR DEATH!⁷² The people of Quebec no longer tolerated the arrogant domination of Anglo-Saxon capitalism. Depicted as the oppressor, the English speaking governed and denied its imperialism with the support of the national elite. The elite showed more preoccupation in the preservation of personal economical interests than the service of the Quebec nation vital interests. The people of Quebec suffered the

⁶⁹ See Appendix 4. Quebec Political Parties and Movements. Bold lines depict the political separatist movement. The *Action socialiste pour l'indépendance du Québec* (ASIQ) represents another early separatist movement. Like many other separatist organizations, the ASIQ held a small membership and eventually dissolved with their members joining the prominent separatist political parties or the FLQ.

⁷⁰ Lionel Bellavance, *Les Partis Indépendantistes Québécois (1960-1970)* (Arthabaska, QC : Le Parti Québécois), 9-11. On the June 6, 1966, separatist political parties obtained roughly eleven percent of the popular vote. The RIN obtained 7,8 percent while the *Ralliement national* (RN) received 3,2 percent.

⁷¹ Fournier, 31-32. The founding members of the FLQ were Raymond Villeneuve, Gabriel Hudon, and George Shoeters. All three were former militants of the RIN. Villeneuve was also part of the ASIQ. Schoeters was originally from Belgium and spent some time in Cuba during the revolution. Hudon and Villeneuve were the more impulsive activists. Hudon advocated the FLQ action parallel to the RIN.

⁷² Comeau, Cooper, and Vallières, 17. The independence theme sits at the forefront and throughout the manifesto. It ends with "*L'INDEPENDANCE OU LA MORT!*" in French. Emphasis in the original text.

effects of colonization politically, socially, and economically. Politically, Quebec possessed no authority over the following areas: economy, foreign trade, defense, bank credit, immigration, criminal law, etc. The federal government could veto any provincial law at its convenience. Economically, out of province interests controlled eighty percent of Quebec's economy. The French Canadians provided the labor; the English speakers pocketed the profits. Socially, English dominated all the sectors including but not restricted to workplace language usage, finance, provincial government, culture, and education, even though eighty percent of the province's population spoke French. French Canadians represented forty percent of the Canadian population in 1940 and twenty-eight percent in 1963. Quebec patriots gained the awareness about the state of colonization, domination, and exploitation they suffered. The thousands unemployed workers, the fishermen and the farmers who barely made a thousand dollars yearly, the thousands of young adults who could not afford an education, the thousands who could not get basic medical care, and the general job insecurity, all symbolized colonialism's results. The situation's recognition and refusal bore a lack of action. A national revolution in independence represented the only way the people of Quebec can live free. The registered political parties promoting independence could not gather the necessary support to defeat the colonial political and economical power. Social revolution had to complement independence.⁷³ According to the manifesto, Quebec political independence represented the FLQ's cause.

FLQ's Protracted Conflict against the Canadian Government

The conflict between the Canadian government and the FLQ started in 1963 in the middle of the Quiet Revolution. The Quiet Revolution offered a fertile ground for many social, economic, and political projects like the Quebec independence. The RIN, a left-wing political

⁷³ Comeau, Cooper, and Vallières, 13-7.

movement, provided the FLQ's foundations. In October 1962, four of RIN's activists met secretly and founded the *Comité de Libération Nationale* to combine clandestine and legal action. The *Comité* attracted around 20 activists and studied political theory and history of revolutionary movements like Algeria, Cuba, and Viet-Nam.⁷⁴ One month later, eager activists from the *Comité de Libération Nationale* formed the *Réseau de Résistance* (RR). The RR executed a first wave of graffiti, vandalism and sabotages that spreaded quickly without any organization. Targets comprised of unilingual English signs and symbols of the British rule, and federal government establishments. The lack of organization led to an uncontrolled escalation and the dissolution of the RR.⁷⁵

From these two groups, Raymond Villeneuve, Gabriel Hudon, and Georges Schoeters formed the FLQ in February 1963. The FLQ sought to organize into a clandestine revolutionary movement with political, military and propaganda wings for efficiency and secrecy. Reversal of the minority Diefenbaker federal government and the RIN's entrance as a registered provincial political party prompted the FLQ to action. March 1963 marks the beginning of the employment of bombs. The Canadian government quickly understood the FLQ as a threat to security and national unity. On June 1 1963, the FLQ met and agreed to restructure in two distinct wings overseen by a central committee named *La Cognée* network.⁷⁶ The FLQ represented the political wing and the *Armée de Libération du Québec* (ALQ), the military wing.⁷⁷ Successful infiltration of the FLQ resulted in twenty-three arrests including its founding trio. This marked the end of the FLQ's first political wing. However, the foundations of the central committee and the military wing remained intact.

⁷⁴ Fournier, 28. The National Liberation Committee represents an unofficial translation..

⁷⁵ See Appendix 1.

⁷⁶ *La Cognée* produced a newsletter twice a month.

⁷⁷ Fournier, 44.

From a unique organization concept, the FLQ became a complex group of cells, including the ALQ as its military wing, *La Cognée*, and many other groups loosely interrelated. *La Cognée* advocated that the FLQ had to build itself as a clandestine revolutionary party in order to form a unified national front of liberation force and prepare an eventual armed uprising.⁷⁸ *La Cognée* acted as both the central committee and the second political wing, and recruited more than a hundred activists. While the propaganda and bombings continued, the ALQ committed successive robberies to acquire weapons, explosives and money from the summer of 1963 until its dismantling in April 1964 by the CATS. In June 1964, the *Armée Révolutionnaire du Québec* (ARQ)⁷⁹ rapidly filled the void left by the dismantling of the ALQ with three retired military members of the Canadian Forces leading the new military wing. The ARQ established a training camp to train the activists around June 1964. The ARQ attempted to gather more arms for the expansion of the military wing. Following, two successful weapon thefts, a third commando operation on a Montreal armory derailed leading to the dismantling of the ARQ. The central committee criticized the impatience leading to ARQ's initiatives. *La Cognée* advocated the union of all revolutionary forces. After many successful interventions by the police and the antiterrorist squads, the FLQ's military wing fell into an incipient mode, preventing any possible growth to the small-stage of insurgency. Following these events, *La Cognée* became cautious and gave warning to all subsequent military operations that became exceptions for the rest of the FLQ's existence.

⁷⁸ Fournier, 55. "*La stratégie officielle du réseau de la Cognée, avec certaines variantes, c'est que le FLQ doit se construire comme parti révolutionnaire clandestin, en vue de constituer un Front national unifié des forces de libération.*"

⁷⁹ *Ibid.*, 80.

In June 1965, Pierre Vallières and Charles Gagnon created the *Mouvement de Libération Populaire* (MLP).⁸⁰ The MLP represented the overt merger of four networks including *Parti Pris*. The MLP wanted to regroup forces and form the core of the vanguard and cadre of the Revolutionary party. The MLP planned to augment popular support by using propaganda, agitation, and networking among the workers. The movement targeted the unemployed workers as well as workers with grievances. Vallières also joined the FLQ and published articles in *La Cognée*. In December 1965, Gagnon and Vallières ended their overt implication with the MLP to focus clandestinely on the FLQ. *La Cognée* network separated in two entities: the national edition still focused on independence, and the socialist edition prepared the revolution. Vallières and Gagnon led the socialist entity and became the central committee. The central committee planned to oversee three networks: the propaganda cell, the action cell and the *Comités Populaires de Libération*.⁸¹ *La Cognée* socialist edition published editions for the union workers and the students.

La Cognée socialist flourished while the nationalist edition stopped all activities. September 15, 1966 marked the end of the socialist edition of *La Cognée* following a RCMP operation. The arrests took place during two weeks while Vallières and Gagnon spent time in the United States trying to link with leaders of the Black Power movement. Vallières and Gagnon found out about the arrests just as they planned to go back home. After manifesting the FLQ's cause in front of the United Nations in New York, the United States immigration authorities arrested Vallières and Gagnon and handed them to the RCMP. *La Cognée* nationalist edition started to publish again following the end of the socialist edition. In November 1966, the *Comité d'aide au Groupe Vallières-Gagnon* (Neo-FLQ) started propaganda and agitation during the trials

⁸⁰ Fournier, 112. The Popular Liberation Movement represents an unofficial translation.

⁸¹ Ibid., 120. The Popular Liberation Committees represents an unofficial translation. They represented clandestine committees formed in workplaces, towns and cities.

of Vallières and Gagnon. The committee collected money for Vallières and Gagnon's defense and explained the meaning of FLQ's actions.

In 1967, Montreal prepared to host the 1967 International and Universal Exposition. April 15, 1967 marked the end of *La Cognée* network. The RCMP maintained its infiltrations while the FLQ's operations almost came to a standstill. A new FLQ propaganda network titled *La Victoire* appeared. *La Victoire* published professional articles on weapons handling, bomb making, and other terrorist tactics. The new propaganda network military focus stood out in comparison to the more political *La Cognée*. The political trials of Vallières and Gagnon opened the year 1968. Vallières published his manuscript titled *White Niggers of America*. Vallières and Gagnon figured as FLQ's ideological leaders and martyrs, when both found guilty. On March 14, 1968, another police infiltration knocked out *La Victoire*.

The beginning of 1968 marked the split of the RIN. RIN's right wing joined René Lévesque's MSA while its extreme left wing divided again to form the *Front de Libération Populaire* (FLP) and the *Comité Indépendance-Socialisme* (CIS). The FLP used propaganda and agitation. On May 9, 1968, a first common front of twenty-five committees of citizens from poor urban neighborhoods reunited in a general assembly. Forty bombs, most by the Geoffroy network, exploded in the City of Montreal during the last seven months of 1968. Two of them targeted the headquarters of two political parties, the PLQ and the *Union Nationale*.⁸² From their cells, Vallières and Gagnon urged the population to action. "You must act quickly. Winning the battles happens through action and in the street. Even though violence represents a detestable phenomenon, freedom for the exploited and colonized comes using rifles."⁸³ Vallières further suggested the commitment of two political kidnappings in exchange for his release. On the

⁸² See Appendix 4.

⁸³ Fournier, 163.

political scene, the *Parti Québécois* (PQ) united the independence political parties and movements. Only the extreme left FLP and CIS did not join the PQ. The FLP and CIS eventually merged as the FLP in 1969. On March 4, 1969, the police arrested Pierre-Paul Geoffroy. Sentenced to life imprisonment, Geoffroy did not reveal any FLQ organizational details. Following other student demonstrations, elements of army intelligence deployed on campuses to monitor and infiltrate the student networks. More bombings and unrest led to a massive frontal offense targeting the committees of citizens, and the leftist groups on October 12, 1969. Many intelligence reports accounted for up to 3,000 terrorists in the province of Quebec. The police convinced politicians from Ottawa, Quebec and Montreal of the existence of a conspiracy linking the FLP and FLQ to Cuba, Algeria and Moscow. By the end of 1969, other networks rose including the Lanctôt-Rose network. The Lanctôt-Rose network used multiple frauds and hold-ups to finance its *Libération* and *Chénier* cells.

The beginning of 1970 marked the start of the planning of diplomat kidnappings and the release of Charles Gagnon. On February 26, the police stopped a plot to kidnap Israel's consul in Montreal, Moshe Golan. The FLQ declared a truce while waiting for the results of the April 29 provincial election. The PQ finished second with 23 percent of the electoral vote behind the PLQ. The week following the elections, the bombings resumed and Pierre Vallières obtained his release. Vallières restated his FLQ affiliation. On June 21, the CATS stopped a conspiracy to kidnap the United States' consul in Montreal, Harrison W. Burgess. In Ottawa, a bomb detonated outside the Headquarters of the National Defence. The FLQ claimed responsibility for the bombing. On October 5, 1970, the *Libération* cell kidnapped the British trade commissioner James Richard Cross. The government refused all FLQ's demands.⁸⁴

⁸⁴ Fournier, 293. The following lists FLQ demands: the publication of the FLQ manifesto, the release of 23 political prisoners, safe passage to Cuba or Algeria, reinstatement of 450 Canadian Post

Thirty minutes after the Quebec government response, kidnappers seized Pierre Laporte leaving Quebec in shock. On October 15, 1970, 3,000 people gathered at the Centre Paul-Sauvé in Montreal to listen to four speakers including Pierre Vallières and Charles Gagnon. On October 17, 1970, a week after the second kidnapping, an unknown informer called a radio station with new information about Laporte. The police found his body in the trunk of a car at the St. Hubert airfield near Montreal. The day before, Ottawa's House of Commons voted 190 to 16 in favor of the legislation to approve the application of the War Measures Act (WMA). Canada Prime Minister's statement on national television was simple; the FLQ will not shake Canada. Negotiations for Cross' release continued until December 3. Upon his release, the members of the *Libération* Cell obtained safe passage to Cuba. Before the end of 1970, the police arrested members of the *Chénier* cell responsible for Pierre Laporte's kidnapping and murder as well as related supporting cells.

The Canadian Army ends Quebec occupation on January 4, 1971. The FLQ continued the bombings and demonstrations but failed to organize. On October 16, 1971, 5000 people gathered in Montreal to commemorate WMA's first anniversary. The riot squad intervened marking the last FLQ demonstration of significance. The government rooted out the remaining FLQ cells. On December 13, 1971, Vallières announced his farewell to arms and joined the PQ in the legitimate political arena. The last attempt to reorganize the FLQ ended during the fall of 1972. The PQ gained in popularity. Quebec elected the PQ to successive governments in 1976 and 1980.⁸⁵ In the

Office workers, \$500 000 in gold, identification of the informer who betrayed the FLQ on their earlier attempt of kidnapping the American Consul Harrison Burgess, and immediate cessation of all police activity in the hunt for the kidnapped diplomat James Richard Cross.

⁸⁵ During the October 29, 1973 election, the PQ finishes second with thirty percent of the electoral vote and represents the official opposition. The PQ elects consecutive majority governments in 1976 and 1980. The PQ holds two referendums on Quebec sovereignty in 1980 and 1995. The referendums gather 40 percent in 1980 and 49,4 percent in 1995. The PQ required 51 percent to start negotiating with the Canadian federal government

end, both FLQ's revolutionary approach and the PQ's political approach failed. The PQ came within one percent of gathering enough support to negotiate an association with Canada and obtain independence. Even though the FLQ battled for nine years, the government's actions kept the movement far from the independence goal.

The RIN ended up providing the FLQ with direct and indirect support throughout its existence. Political parties like the *Ralliement National* and later on, the PQ stuck strictly to politics. The RIN, the FRI, the MLP, and the FLP promoted unrest using propaganda, agitation, and sometimes, violent demonstrations. This situation made it complex for the government to differentiate between political members and insurgents. Overt movements often operated semi-clandestinely.

FLQ's Use of Violence, Subversion and Political Resources

Even though the FLQ lacked in numbers, it successfully used violence, subversion, propaganda and demonstrations. From 1963 to 1970, the FLQ employed more than 200 bombs,⁸⁶ targeting symbols of Canadian federalism, British establishment, English speaking institutions and businesses, and elements of the provincial and municipal levels of government. The use of violence served to destroy symbols of government and capitalism, but more importantly to raise the population's awareness to the Quebec independence, and promote FLQ's influence. The bombs provoked a destabilizing effect on the federal government. On April 1, 1963, the discovery of a bomb on a railway line stopped Prime Minister Diefenbaker's train while his electoral campaign visited Quebec. However, the extreme examples of violence came in the form of the two kidnappings during the October Crisis, with the death of Pierre Laporte as the exclamation point. Other failed attempts raised government's concerns. The failed ARQ commando attack at

⁸⁶ Fournier, 471.

military base *La Macaza*, which aimed at destroying Bomarc missiles, represented evidence that the FLQ could plan major operations against national security.⁸⁷ On June 24, 1968, during the *Fête de la St-Jean*, a small demonstration protesting against the presence of Justice Minister Pierre Trudeau turned into a riot. The following day, Canada elected Trudeau's PLQ with a majority government. The riot and the federal election's results fueled the rise of violence. The FLP and CIS gathered the support of the students and the *Mouvement de Libération du Taxi* (MLT) to block Montreal's Dorval International Airport and other traffic strategic points. In October, Stoke Carmichael, leader of the Black Panthers, visited to promote the revolution.⁸⁸ A rise in bombing activities and violence marked the end of 1968 and the beginning of 1969, including one bomb at the Montreal City hall and another one at the Montreal Stock exchange. The FLQ explained the one million dollar damage to the stock exchange building as a hit to Quebec's central exploitation system. In total, FLQ's violence resulted in nine deaths over eight years. Law enforcement actions against the FLQ represent a reason why the number of deaths stayed low.

FLQ's most successful attempt to undermine the HN government's legitimacy happened on October 10, 1964, during the visit of Queen Elizabeth II of England. The Queen's visit warranted extraordinary security measures including refraining from visiting the turbulent Montreal metropolis and stopping in Quebec City instead. The government feared a second JFK and left nothing to chance. *La Cognée* invited all FLQ activists to join members of the RIN in welcoming the Queen. The police interdicted the demonstration that ended under heavy suppression. The international Press discovered the magnitude of the Quebec question through

⁸⁷ Ibid., 106. La Macaza represented one of many North American Aerospace Defense Command (NORAD) installations. The base sheltered Bomarc missiles armed with nuclear warheads.

⁸⁸ Ibid., 181. Carmichael encourages the population to use all available rifles because nobody becomes a true revolutionary until ready to take up arms and kill to defend your brothers.

the harshness of law enforcement actions. The FLQ managed to foment violent civil unrest starting in 1968. This period marked the beginning of the workers, students and teachers demonstrations that indirectly supported the FLQ. Coincidental or not, English companies like Murray Hill, Seven-Up, and Victoria Precision Works all experienced labor conflicts with French speaking workers. The conflicts presented the FLQ with unique sources of support among the workers, and opportunities for strikes and riots based on language-based grievances. Language-based grievances also existed in education. In the greater Montreal area, teachers, students and parents requested changes such as new French schools and a second French university. The latter provided grounds for a 15,000 people demonstration that took place at McGill University, an English speaking institution, during *Opération McGill français*. Massive mobilization by students and teachers preceded the adoption of Bill 63 that granted parents the freedom of choosing their child education language. Gatherings of 20,000 and 35,000 people to protest Bill 63 in Montreal, forced the Municipal Council to adopt *Règlement 3926*, prohibiting public gatherings and demonstrations. The FLQ, through his Geoffroy Network, participated in these workers and students demonstrations. The FLQ used every worker strike involving an English employer, and new federal or provincial government legislation modifying the use of the French language as an instrument to cause subversion. The FLQ benefitted from the FLP's creation of workers committees to expand the reach of subversion and violence. Openly implicated with workers, the FLP unofficially became FLQ's political vanguard.⁸⁹ FLQ's subversive efforts demonstrated opportunism. On October 7, 1969, Montreal police and firefighters went on strike. The FLQ, FLP, and MLT assaulted the Murray Hill Company's garage. The assault turned into a riot throughout the streets of Montreal.

⁸⁹ Fournier, 205-6. See Appendix 2.

During 1968 to 1970, FLQ's propaganda came primarily from Pierre Vallières' prison cell. The situation contrasted with the 1963 to 1968, when *La Cognée* and *La Victoire* formed the vehicle of FLQ's propaganda. Vallières contributed an article to FLP's monthly *La Masse*. The article titled *Stratégie révolutionnaire et rôle de l'avant-garde*, depicted the theoretical scheme of a long war.⁹⁰ The *Comité d'aide au Groupe Vallières-Gagnon* represented the other source of propaganda. The use of propaganda kept the FLQ going during the times when law enforcement weakened it the most. Along with the presence of the RIN, and later on, the FLP and the CIS, the propaganda brought the FLQ insurgency much needed support.

FLQ's Popular Support

The use of propaganda, and violence provided the FLQ's popular support. However, FLQ's political relationship with the RIN, the MLP, and the FLP brought direct and indirect support. The direct support came to revive the FLQ when law enforcement dismantled its military wings. The indirect support brought followers. For example, the RIN provided the FLQ, the Geoffroy Network that became instrumental in gathering students and workers support during the late 1960s. The RIN's left wing that decided not to join the PQ became the FLP. The FLP provided links to the union workers support. The FLQ's popular support proved just enough to help it survive in the proto-insurgency stage.

The unexpected moral external support provided by France's President, Charles de Gaulle during his Canadian visit for Expo 67, brought support to the separatist movement. President de Gaulle's 'Vive le Québec libre!' revived FLQ's support right after the dismantling of

⁹⁰ Ibid., 206-7. A copy of Pierre Vallières' article fell in the Montreal police possession. To the police, this represented the secret plan of a revolution in the making. The Revolutionary Strategy and the vanguard role represents an unofficial translation of Vallières' article.

the Vallières-Gagnon Network.⁹¹ If the popular support kept the FLQ's insurgency alive, the lack of popular support brought the end of the movement. The gradual withdrawal of popular support, following the Pierre Laporte assassination, signified the FLQ's end. For the supporting population, the shared cause of Quebec's independence offered sufficient justification for riots, demonstrations, and bombs causing little or no casualties. The cause presented little justification, however, for what looked like a cold-blooded assassination. The exodus of FLQ's popular support came to the benefit of the legitimate separatist political PQ.

The FLQ was an insurgency. The presence of four characteristics of an insurgency demonstrates it. First, the pursuit of Quebec's independence represented FLQ's cause. Politically, the FLQ sought Quebec's self-determination and authority. Economically, the FLQ wanted the profits to benefit the Quebecers, not foreign interests. Socially, the FLQ's advocated French as the primary language at work, at school, in the government, in finance, and in culture. The FLQ's grievances gained traction when Lester B. Pearson's Liberal Party of Canada instituted French as Canada's second official language. Second, the FLQ took part in a nine-year political struggle with the Canadian government. The FLQ pursued a political change in the form of Quebec's secession from the Canadian Confederation. Third, the FLQ used violence, subversion, and political resources such as propaganda and demonstrations to achieve the desired political change.

⁹¹ Fournier, 142-4. President de Gaulle had two scheduled speeches in Quebec City and in Montreal. During his first speech, he stated, "We witness here, as in many regions of the world, the advent of a population who, across all areas, wants to have itself in charge, and take control of its destiny. This advent, it is with all her soul that France salutes it." During his second speech, de Gaulle went on to compare his entrance in Montreal to the one he did in Paris in August 1944 following the end of German occupation. "Tonight, here and along the road leading here, I found myself in an atmosphere similar to the Liberation's. 'Vive le Québec libre!' Prime Minister Lester B. Pearson's response that Canada did not need liberation made the undesirability of the French President's presence clear. The federalist Canadian media also criticized President de Gaulle's statement, describing it as an implied threat to Canada's territorial integrity. Following these two speeches and the Prime Minister's comments, the French President decided to shorten his visit. He cancelled his visit to Ottawa and went back to France.

Fourth, the FLQ sought and obtained popular support through the independence political arena, the unemployed, the union workers, and the students.

However, the FLQ failed as an insurgency. The FLQ insurgency failed to grow past the proto-insurgency stage. Conditions created and actions taken by the government made organizing, self-sustainment, and growing, impossible for the FLQ. A look at the government's actions follows.

Section 4 – Government's Actions against the FLQ

Achievement of an accurate description of the Canadian government's actions happens best using a metaphor. To use Peter Schifferle's metaphor, "Just as crabgrass withers when exposed to harsh sunlight, denied water, and vigorous uprooting, so will terrorism wither when exposed to the heat of international censure, denied support from sympathetic governments, and attacked and vigorously rooted out from its sanctuaries."⁹² In essence, the federal, provincial and municipal governments' collaboration kept the FLQ insurgency from growing beyond the proto-insurgency stage. Based on Daniel G. Cox' recent *Small Wars Journal* article depicting the Iranian government actions against their incipient insurgency, this section highlights Canadian government's actions in three domains of interests: the effective intelligence gathering promoting recognition and understanding of FLQ's organization, the use of coercive measures to quell the FLQ, and the control of the FLQ's message.

Immediately after the first bombs in 1963, the government took action. Following 1962 RCMP preliminary written reports on the possibility of a terrorist movement in Quebec, the RCMP formed a special squad composed of agents from its Intelligence and Security Service, and its Criminal Investigation Bureau. The squad opened file D-928 listing separatist activists

⁹² Peter J. Schifferle, "Terrorism and Crabgrass," *Military Review* LXXXI, no. 6 (November-December 2001): 2.

allegedly linked to terrorism activities.⁹³ Gathered intelligence provided the starting point for understanding the organization of the FLQ. With the FLQ's independence cause and grievances known, intelligence sought solely to expand and confirm the existing lists of FLQ supporters with a view of informing future operations to weed the military and political wings out. The RCMP remained the lead agency for intelligence gathering and dissemination. The intelligence services of the Canadian Forces played a collaborative role, albeit a minor one. To confirm intelligence prior to a direct operation, law enforcement agencies recruited informants using a reward system. Informants proved invaluable to infiltrate the FLQ throughout the conflict. The government's challenge lied in finding the time and place to infiltrate and use informants. Intelligence gathering required direction. The federal government Security Council provided the guidance twice during the conflict.

On September 23, 1964, prior to Queen Elizabeth II's visit, the Council decided to extend D-928 list to members of democratic separatist movements like the RIN. Prime Minister Pearson displayed little complacency and stated that separatism threatened Canada's security as seriously as communism.⁹⁴ Within this new context, the RCMP required to employ extended human and technical sources to collect intelligence on separatists. The use of extended sources created the FBI and RCMP cooperation linking the FLQ with the Black Liberation Front early in 1965. The second Council guidance came on August 14, 1967, three weeks following President de Gaulle's visit. Following President de Gaulle speeches, the federal government no longer saw separatism only as a security threat, but also as a political threat. The broadened directives given to RCMP mixed up national unity, national security, overt independent movement, and clandestine and

⁹³ Fournier, 38.

⁹⁴ Ibid., 91-2.

violent movement.⁹⁵ In summary, anyone involved with Quebec separatist movement became a suspected insurgent. The expression of federal intelligence guidelines correctly identified the situation. The FLQ, a clandestine movement, sometimes used legitimate political movements as temporary sanctuaries. The government sought to attack these sanctuaries actively. An informant enabled the dismantling of FLQ's first political wing on June 1, 1963 during a FLQ strategy and reorganization meeting.⁹⁶ The raid further provided the authorities with expanded lists of FLQ members. Through the combination of sweeps and infiltration raids, the government law enforcement systematically rooted out the FLQ.

With intelligence gathered, the government used its law enforcement effectively assuming risks by sweeping known separatist movement locations. As an example, on April 12, 1963, the Montreal Police and the RCMP conducted a sweep of all the Montreal separatist circles without warrants, or summonses. The operation raised criticism from the separatist circles about the coercive nature of the intervention. The following week, a demonstration against police repression took place in front of RCMP headquarters in Westmount. The police charged and ended the demonstration quickly injuring many.⁹⁷ The coercion took a physical dimension to send a message to people intending to support the FLQ. Beyond the message sent, the sweep proved effective as law enforcement gathered more intelligence. The widespread sweeps answered the government's challenge to differentiate between insurgents and political activists. The same scheme of maneuver became the norm of the sweeps of October 1969 and October 1970. The coercion sent the right message with the right intensity.

⁹⁵ Fournier, 146-7.

⁹⁶ Ibid., 44-6. The Montreal police and the RCMP arrested 23 people including the founding members of the FLQ. See Appendix 1 for timeline.

⁹⁷ Ibid., 39. Westmount represents the Western part of Montreal Island where the English-speaking majority lives.

The government's biggest challenge lied with the FLQ's propaganda. Success with intelligence and operations came quickly and regularly. Controlling FLQ's message turned into a four-year struggle. *La Cognée* formed the elusive target despite police's efforts. Published twice a month at around 100 copies, the newsletter reached 3000 for many numbers. *La Cognée* represented a body for liaison, organization, training, and combat.⁹⁸ Unlike all other separatist magazines and newsletters published, the FLQ distributed *La Cognée* clandestinely. From the first number in October 1963 to the last on April 15, 1967, *La Cognée* carried the FLQ's message bringing popular support and new membership. Law enforcement agencies often found numbers of *La Cognée*, they just could not find the printing and distribution networks. Just as infiltration operations permitted the elimination of FLQ's political and military wings, *La Cognée* had the same fate in 1967. By taking out *La Cognée*, the government accomplished the third part of attacking an insurgency in the proto-insurgency stage, controlling the message. Law enforcement knocked out *La Victoire*, *La Cognée*'s successor, in similar fashion the next year.⁹⁹ The FLQ's ability to gain popular support and attract activists would come through the FLP and other overt movements. Outside the evidence that the government gathered intelligence to promote understanding of the FLQ, used coercive countermeasures, and controlled the FLQ's ability to spread its message, laid other important themes.

First, the Canadian government heeded the FLQ's warning seriously. Avoiding a quick dismissal of a relatively small threat provided continued success in hindering FLQ's growth past the proto-insurgency stage. More precisely, taking the threat seriously prevented the FLQ's from growing one or many small armies. By quelling such a threat, the government avoided possible conflict expansions such as guerilla wars. Secondly, the government expanded the definition of

⁹⁸ Fournier, 55.

⁹⁹ See Appendix 2. The Vallières-Gagnon Network represented the second FLQ Central Committee while *La Cognée* stayed as FLQ's second Political Wing.

the threat when clues indicated so. Repeated demonstrations and agitation involving the FLQ alongside the RIN and the FLP indicated a blurred border between the clandestine and violent movement, and legitimate political movements.

Finally, the government, willingly or not, took some risks. The law enforcement agencies raided and swept without warrants and due process, and preventively detained people in search for more intelligence to define the FLQ's environment and problem. The use of these coercive countermeasures and rough tactics sent the message to the separatists, clandestine and violent or not, the government took matters seriously. With the kidnappings of two officials accomplished, the government assumed the FLQ's strength at the small-scale insurgency stage. No longer positive that the enhanced police capabilities could contain the insurgents' violence, the government found the requirement of using the Canadian Forces. With Quebec in shock after the Pierre Laporte assassination, the government took the risk of suspending the population's liberties and proclaimed the War Measures Act, imposing curfews and putting the army in the streets of Montreal. Proportional to the threat or not, the Canadian government managed to stop the FLQ's attempt to overthrow or force political change of the governing authority by the use of violence, subversion, and political resources. The legitimate political party prevailed in the end, however, the PQ did not achieve Quebec's independence either.

Section 5 – Conclusion

The monograph argued that the FLQ was an insurgency. It further demonstrated that the Canadian government's actions kept the FLQ insurgency from growing past the proto-insurgency stage. One can immediately question the importance of such a finding. History abounds with examples of governments that reacted when the insurgency reached the small and large-scale stages. These governments immediately had to rely on their armed forces because the insurgency violence represented more than their police could handle. However, literature does not present

many cases where the government identified an insurgency in the proto-insurgency stage and crushed the movement before it moved to the small and large-scale stages.

In the case of the FLQ, the Canadian government received many indicators. The most important one remains the growth of a movement that wanted to become a nation outside of Canada. This evidence contradicted the very founding principles of the Canadian Confederation, which include the preservation of ties with Great Britain, allegiance to the Queen, and the recognition of a central federal government in Ottawa. The use of violence against federal institutions, symbols of British rule, and English businesses represented the second indicator. As these indicators grew in frequency, the Canadian government recognized the potential for bigger problems if measures did not address the violence.

Theorists like O'Neill argue that governments hold the advantage while an insurgency remains only in the making. However, O'Neill also states that governments show complacency judging the proto-insurgency too small to warrant any immediate action. The Canadian government avoided that road and chose a more proactive approach to the FLQ. Even though the RCMP held little jurisdiction in Quebec because of the *Sûreté du Québec* provincial police's presence, the Canadian government gave it the responsibility to gather intelligence about the FLQ and other separatist movements. When the actions of legitimate politically registered parties and movements blurred the situation, the government immediately broadened the RCMP's mandate to include the separatist political parties as part of the threat to security and national unity.

At the tactical level, the government relied heavily on intelligence-based infiltrations to root out elements of the FLQ. The identification of FLQ's political wings followed by direct operations to take them out hindered any level of organization the FLQ tried to achieve. More importantly, the government's law enforcement agencies kept the level of violence employed to a reasonable level, well within the limits of tolerance of the population.

The recommendations based on the FLQ insurgency case study present little novelty. First, a government should avoid complacency when facing an insurgency in the proto-insurgency stage. Dedication of efforts and resources to identify accurately the cause and grievances of the insurgency represent a critical step towards defining the type of insurgency. Second, the gathering of intelligence informs the choice of the correct COA. The government must judiciously choose the COA to avoid giving the insurgency any legitimacy. However, the government must take some risks and sometimes use coercive countermeasures. The Canadian government arrested people part of separatist movements without warrants, and held them for up to two days to gain more intelligence and send the right message to people supporting the FLQ. These risks paid off as little negative impacts resulted from the suspension of some basic civil rights. Finally, the government must control the insurgency's message as quick as possible. The government took four years to dismantle *La Cognée* Network, which resulted in giving the FLQ enough popular support to survive. *La Cognée* represented FLQ's messenger. Replacing *La Cognée* with *La Victoire* lasted only a few months, after which the FLQ relied on the networking through overt separatist movements. A government that successfully accomplishes these three actions augments the chances of success. An insurgency at the proto-insurgency stage possesses little chances to grow under such conditions.

Studying insurgencies at the proto-insurgency level reveals a lot about what an insurgency is and how a government can influence its growth. A study case like the FLQ further highlights how the odds of a government defeating an insurgency become higher, when the insurgency's identification and understanding happen early. However, the government must apply proactive actions and show the willingness to take some risks, including the consideration of an appropriate use of coercive countermeasures, to improve the odds in its favor.

Appendices

Appendix 1 – FLQ Map (1961–1965)

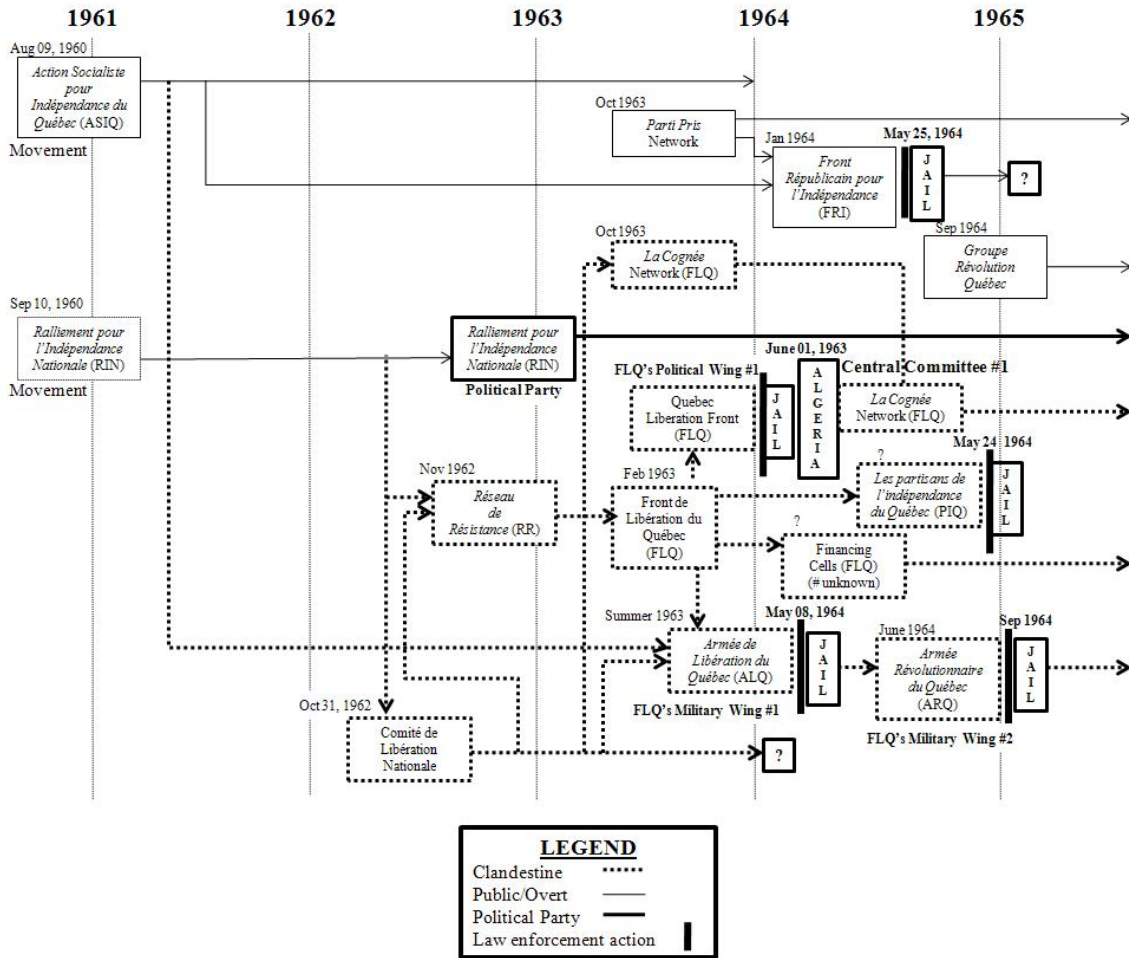

Louis Fournier, *FLQ: Histoire d'un mouvement clandestin*, rev. ed. (Outremont, QC: Lanctôt Éditeur, 1998), 11-494

- Notes:
- 1- Public/Overt organizations and movements often operated semi-clandestinely.
 - 2- La Cagnée Network took over after the dismantling of FLQ's Political Wing #1.
 - 3- Many non-represented movements and cells also existed.

Appendix 2 - FLQ Map (1965–1969)

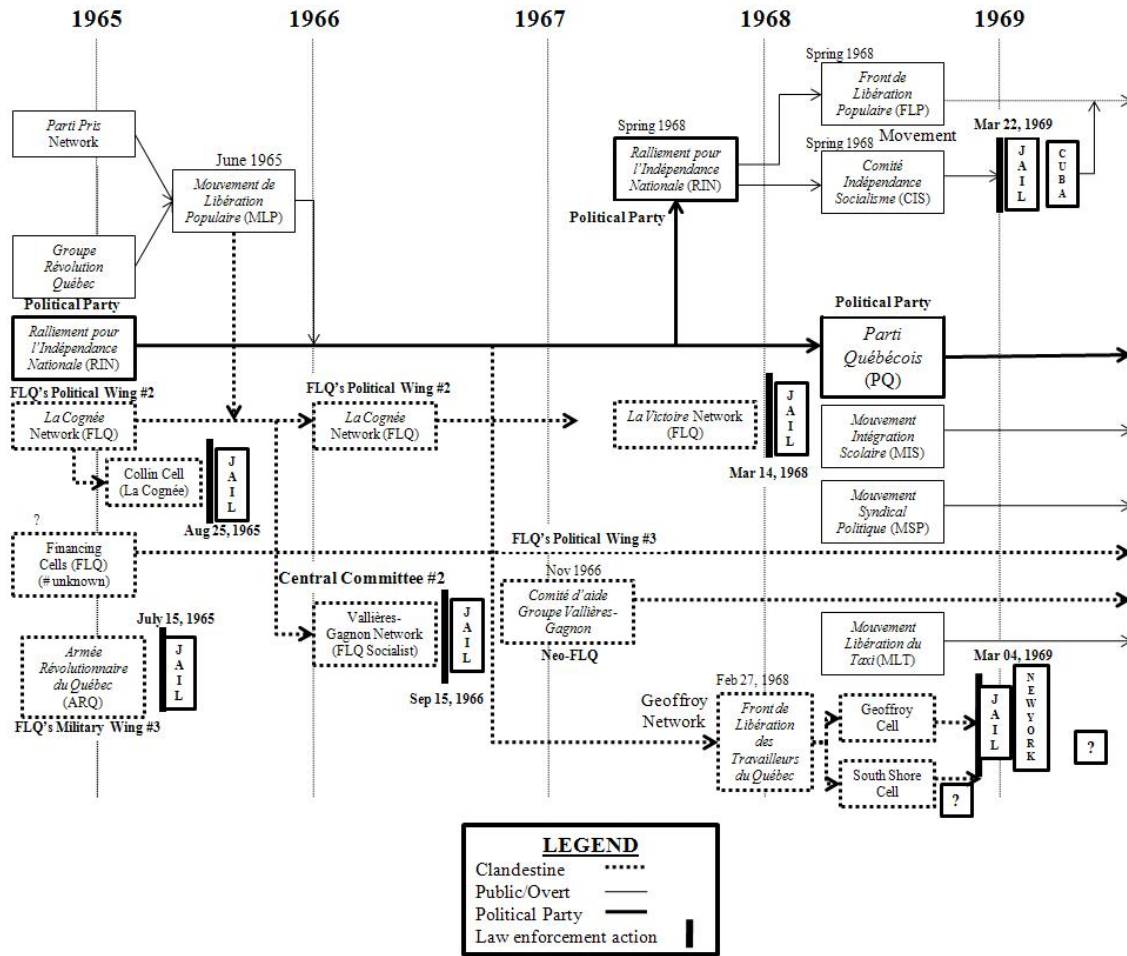

Louis Fournier, *FLQ: Histoire d'un mouvement clandestin*, rev. ed. (Outremont, QC: Lanctôt Éditeur, 1998), 11-494

- Notes: 1- Public/Overt organizations and movements often operated semi-clandestinely.
- 2- The *Comité d'aide au Groupe Vallières-Gagnon* clandestine nature remains unclear.
- 3- Many non-represented movements and cells also existed.

Appendix 3 - FLQ Map (1969–1972)

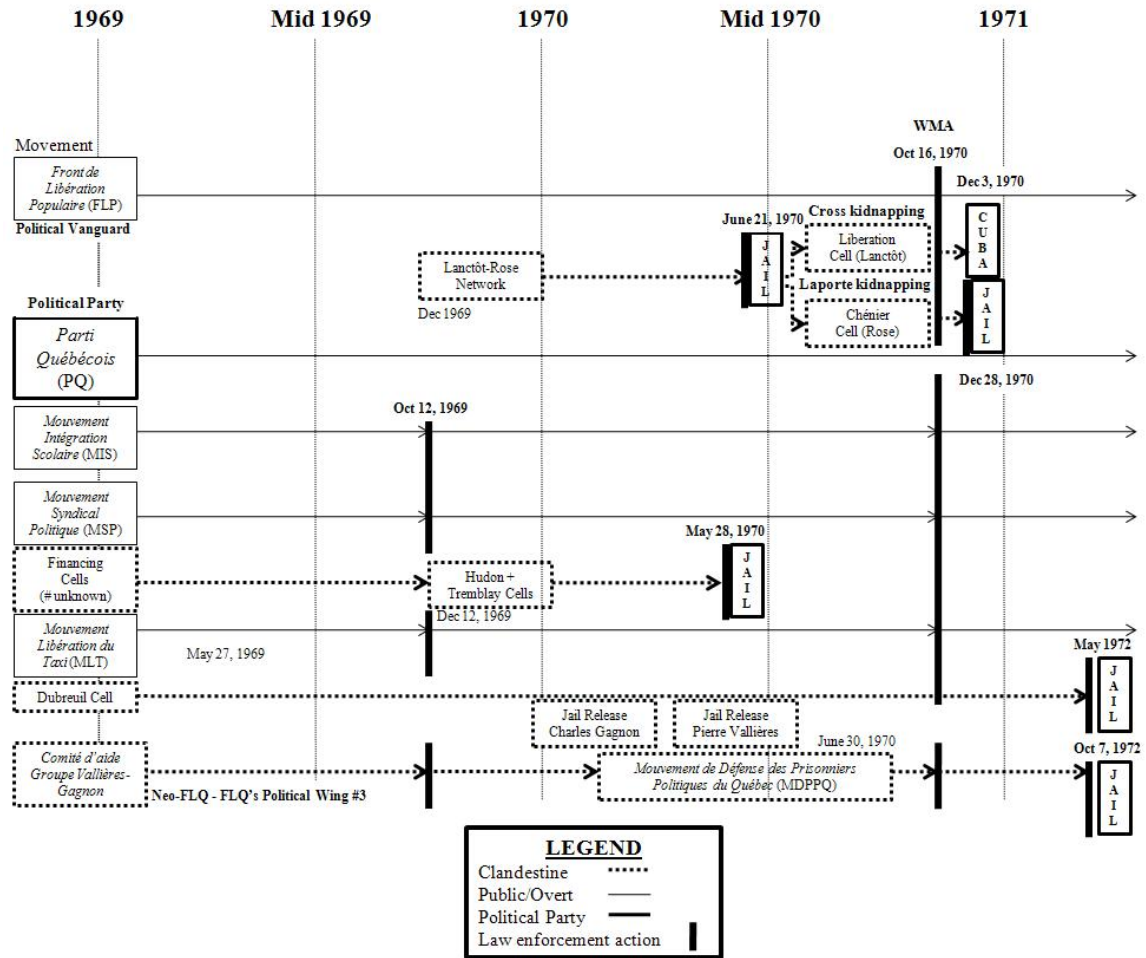

Louis Fournier, *FLQ: Histoire d'un mouvement clandestin*, rev. ed. (Outremont, QC: Lanctôt Éditeur, 1998), 11-494

- Notes:
- 1- Public/Overt organizations and movements often operated semi-clandestinely.
 - 2- Pierre Vallières announces his farewell to arms December 13, 1971 to join the PQ.
 - 3- Many non-represented movements and cells also existed.
 - 4- FLP's status as the FLQ's Political Vanguard remained unofficial.

Appendix 4 – Quebec Political Parties and Movements

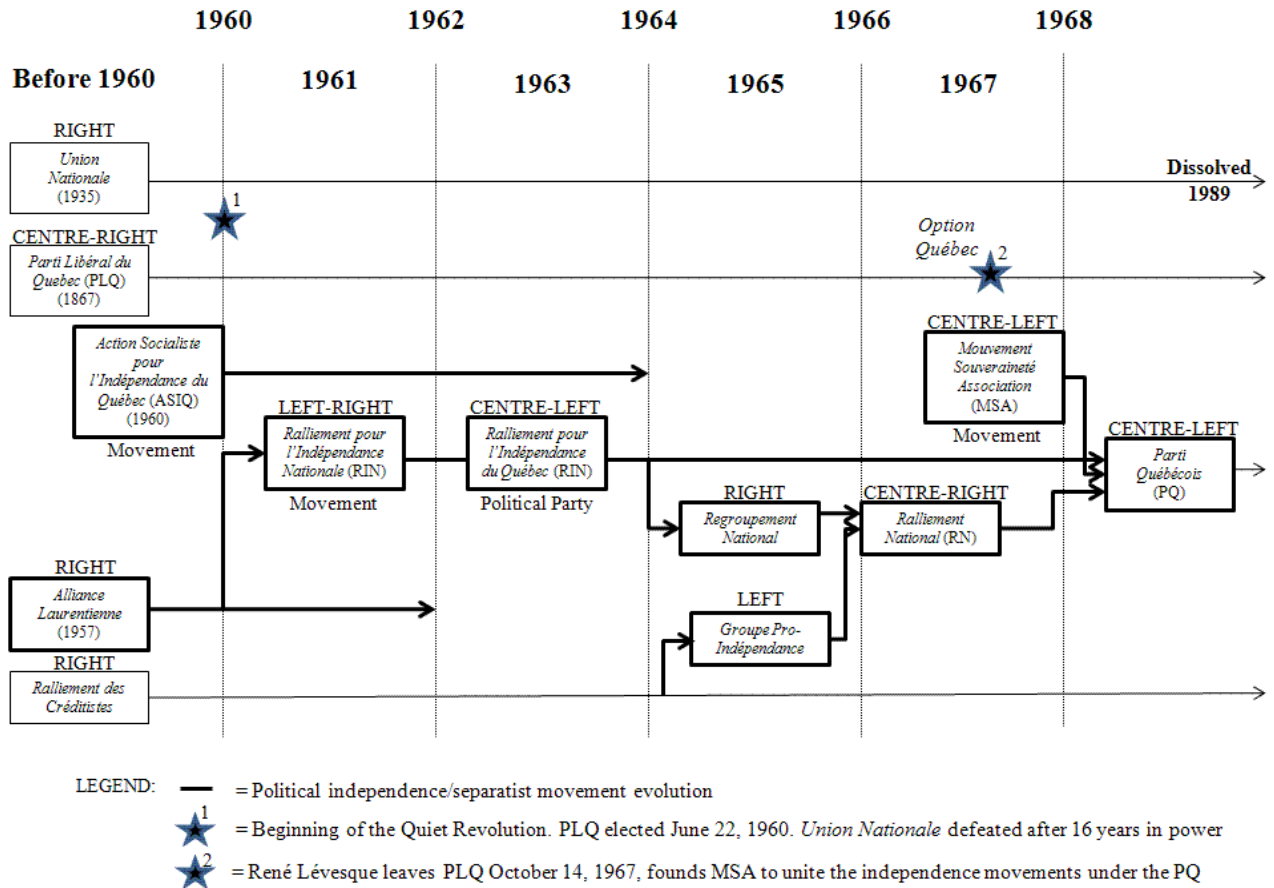

Bibliography

- Axelrod, Robert, and Michael D. Cohen. *Harnessing Complexity: Organizational Implications of a Scientific Frontier*. New York: The Free Press, 2000.
- Basilici, Steven P. and Jeremy Simmons. *Transformation: A Bold Case for Unconventional Warfare*. Monterey, CA. Naval Postgraduate School, June 2004.
- Bédard, Éric. *Chronique d'une insurrection appréhendée: La crise d'Octobre et le milieu universitaire*. Sillery, QC : Éditions du Septentrion, 1998.
- Bellevance, Lionel. *Les Partis Indépendantistes Québécois (1960-1970)*. Arthabaska, QC. Parti Québécois, 1972.
- Cahill, James. "Six Reasons Counterinsurgencies Lose: A Complementary Perspective." *Small Wars Journal*. (July 27, 2009). <http://smallwarsjournal.com/blog/2009/07/six-reasons-counterinsurgencie/> (accessed September 9, 2009).
- Cardin, Jean-François. *Comprendre Octobre 1970: Le FLQ, la Crise et le Syndicalisme*. Montréal: Éditions du Méridien, 1990.
- Clément, Dominique. "The October Crisis of 1970: Human Rights abuses under the War Measures Act." *Journal of Canadian Studies*, 42, no. 2 (Spring 2008): 160-86.
- Comeau, Robert, Daniel Cooper, and Pierre Vallières. *FLQ: un projet révolutionnaire Lettres et écrits felquistes (1963-1982)*. Montmagny, QC: VLB éditeur, 1990.
- Cox, Daniel G. "Unrest in Iran: A Test Case for Counterinsurgency Theory.", <http://smallwarsjournal.com/blog/journal/docs-temp/360-cox.pdf> (accessed March 15, 2010).
- Cronin, Audrey Kurth. "Behind the Curve: Globalization and International Terrorism." *International Security* 27, no.3 (Winter 2002-2003): 30-58.
- Cross, James Richard. "Kidnapping in Canada." *British Journal of Canadian Studies* 5, Issue 2 (1990): 269-74.
- Dagenais, Bernard. *La crise d'octobre 1970 et les médias*. Montmagny, QC : VLB Éditeur, 1990.
- Dederer, John Morgan. *Making Bricks without Straw: Nathanael Greene's Southern Campaign and Mao Tse-Tung's Mobile War*. Manhattan, KS: Sunflower University Press, 1983.
- Department of Defense. Joint Publication 3-24, *Counterinsurgency Operations*. Washington, DC: Government Printing Office, October 5, 2009.
- Department of the Army. Field Manual 3-24, *Counterinsurgency*. Washington, DC: Government Printing Office, 2006.
- Fournier, Louis. *FLQ: Histoire d'un mouvement clandestin*. Rev. ed. Outremont, QC: Lanctôt Éditeur, 1998.
- Galula, David. *Counterinsurgency Warfare: Theory and Practice*. Westport, CT: Praeger Security International, 2006.
- Gompert, David C. and John Gordon IV, eds. *War by other means: Building Complete and Balanced Capabilities for Counterinsurgency*. Santa Monica, CA: RAND Corporation, 2008.
- Grace, Kevin Michael. "Just a few 'young toughs.'" *Report/News magazine (Alberta Edition)* 28, no. 3 (February 5, 2001): 15.

- Hoffman, Bruce. *Inside Terrorism*, rev. and expanded ed. New York, NY: Columbia University Press, 2006.
- Landman, Todd. *Issues and Methods in Comparative Politics*, 3rd ed. New York, NY: Routledge, 2008.
- Leman-Langlois, Stéphane and Jean-Paul Brodeur. "Terrorism Old and New: Counterterrorism in Canada." *Police Practice and Research* 6, no. 2 (May 2005): 121-40.
- Meadwell, Hudson. "The Politics of Nationalism in Quebec". *World Politics* 45, no. 2 (January 1993): 203-41.
- Meren, David. "Les sanglots longs de la violence de l'automne: French Diplomacy Reacts to the October Crisis." *Canadian Historical Review* 88 (December 2007): 613-44.
- Morton, Desmond. "Bayonets in the streets: The Canadian experience of Aid to the civil power 1867-1990." *Canadian Defence Quarterly* 20, no. 5 (April 2001): 30-6.
- National Defence. B-GL-323-004/FP-003 *Counter-Insurgency Operations*. Kingston, ON: Army Publishing Office, 2008.
- O'Neill, Bard E. *Insurgency & Terrorism: From Revolution to Apocalypse*. 2nd ed. revised Washington, D.C.: Potomac Books Inc, 2005.
- O'Neill, Terry. "Diehards with a vengeance: the FLQ attempts to stoke the fires of the flagging Quebec independence movement." *Western Standard* 3.23 (February 26, 2007): 17.
- Pillar, Paul R. *Terrorism and U.S. Foreign Policy*. Washington, D.C.: Brookings Institution Press, 2003.
- Potter, Andrew. "The very very brief history of violence in Quebec." *Maclean's* 120, no. 7 (February 26, 2007): 10.
- Rittel, Horst W.J. and Melvin M. Webber. "Dilemmas in a general Theory of Planning." *Policy Sciences* 4 (1973): 155-69.
- Schifferle, Peter J. "Terrorism and Crabgrass." *Military Review* LXXXI, no. 6 (November-December 2001): 2-3.
- Shy, John and Thomas W. Collier. "Revolutionary War," in *Makers of Modern Strategy: from Machiavelli to the Nuclear Age*, edited by Peter Paret, 815-62. Princeton, NJ: Princeton University Press, 1986.
- Simpson, J.A. and E.S.C. Weiner, eds. *The Oxford English Dictionary*. 2nd ed. Oxford: Clarendon Press, 1989.
- Stewart, James. "Quebec's end of innocence." *Maclean's* 108, no. 41 (October 9, 1995): 22-23.
- Stoker, Donald. "Six Reasons Insurgencies Lose: A Contrarian View." *Small Wars Journal*. (July 4, 2009). <http://smallwarsjournal.com/blog/2009/07/six-reasons-insurgencies-lose/> (accessed September 9, 2009).
- Time. "New York: The Monumental Plot." *Time*. February 26, 1965.
- Trinquier, Roger. *Modern Warfare A French View of Counterinsurgency*. Translated by Daniel Lee. 1964. Reprint, Fort Leavenworth, KS: Combat Studies Institute, 1985.
- Turabian, Kate L. *A Manual for Writers of Research Papers, Theses, and Dissertations*. 7th ed. Chicago: University of Chicago Press, 2007.
- Vallières, Pierre. *Nègres blancs d'Amérique*. Éditions Parti Pris, 1968.

- Wainstein, Eleanor S. *The Cross and Laporte Kidnappings, Montreal, October 1970*. Santa Monica, CA: RAND Corporation, 1977.
- Whitaker, Reg. "Apprehended Insurrection? RCMP Intelligence and the October Crisis." *Queen's Quarterly* 100/2 (Summer 1993): 383-406.
- Hayden White. *The Content of the Form*. Baltimore: The Johns Hopkins University Press, 1987.
- Whyte, Kenneth. "Just assassins: the FLQ's back in the limelight. But Pierre Laporte's still dead." *Saturday Night* 109, no. 10 (December 1994): 22.