

# **Sustaining Operational Maneuver in the Twenty-First Century**

**A Monograph  
by  
MAJ Justin S. Herbermann  
U.S. Army**



**School of Advanced Military Studies  
United States Army Command and General Staff College  
Fort Leavenworth, Kansas**

**AY 2010**

<b>REPORT DOCUMENTATION PAGE</b>			<i>Form Approved</i> <i>OMB No. 0704-0188</i>		
Public reporting burden for this collection of information is estimated to average 1 hour per response, including the time for reviewing instructions, searching existing data sources, gathering and maintaining the data needed, and completing and reviewing this collection of information. Send comments regarding this burden estimate or any other aspect of this collection of information, including suggestions for reducing this burden to Department of Defense, Washington Headquarters Services, Directorate for Information Operations and Reports (0704-0188), 1215 Jefferson Davis Highway, Suite 1204, Arlington, VA 22202-4302. Respondents should be aware that notwithstanding any other provision of law, no person shall be subject to any penalty for failing to comply with a collection of information if it does not display a currently valid OMB control number. <b>PLEASE DO NOT RETURN YOUR FORM TO THE ABOVE ADDRESS.</b>					
<b>1. REPORT DATE (DD-MM-YYYY)</b> 13-05-2010		<b>2. REPORT TYPE</b> SAMS Monograph		<b>3. DATES COVERED (From - To)</b> July 2008 – May 2009	
<b>4. TITLE AND SUBTITLE</b> Sustaining Operational Maneuver in the Twenty-First Century			<b>5a. CONTRACT NUMBER</b>		
			<b>5b. GRANT NUMBER</b>		
			<b>5c. PROGRAM ELEMENT NUMBER</b>		
<b>6. AUTHOR(S)</b> Major Justin S. Herbermann, United States Army			<b>5d. PROJECT NUMBER</b>		
			<b>5e. TASK NUMBER</b>		
			<b>5f. WORK UNIT NUMBER</b>		
<b>7. PERFORMING ORGANIZATION NAME(S) AND ADDRESS(ES)</b> School of Advanced Military Studies (SAMS) 250 Gibbon Ave. Fort Leavenworth, KS 66027-2134			<b>8. PERFORMING ORG REPORT NUMBER</b>		
<b>9. SPONSORING / MONITORING AGENCY NAME(S) AND ADDRESS(ES)</b>			<b>10. SPONSOR/MONITOR'S ACRONYM(S)</b>		
			<b>11. SPONSOR/MONITOR'S REPORT NUMBER(S)</b>		
<b>12. DISTRIBUTION / AVAILABILITY STATEMENT</b> Approved for Public Release; Distribution is Unlimited					
<b>13. SUPPLEMENTARY NOTES</b>					
<b>14. ABSTRACT</b> See attached.					
<b>15. SUBJECT TERMS</b> Sustainment, Logistics, Combat Service Support, Operational Level Logistics, '35MM', Operational Maneuver, Operation COBRA, Operation DESERT STORM, 1 <sup>st</sup> Infantry Division, Normandy, Iraq					
<b>16. SECURITY CLASSIFICATION OF:</b>			<b>17. LIMITATION OF ABSTRACT</b>	<b>18. NUMBER OF PAGES</b>	<b>19a. NAME OF RESPONSIBLE PERSON</b> Stefan J. Banach COL, U.S. Army
<b>a. REPORT</b>	<b>b. ABSTRACT</b>	<b>c. THIS PAGE</b>			<b>19b. PHONE NUMBER (include area code)</b>
(U)	(U)	(U)	(U)	98	913-758-3302

# SCHOOL OF ADVANCED MILITARY STUDIES

## MONOGRAPH APPROVAL

Major Justin S. Herbermann

Title of Monograph: Sustaining Operational Maneuver in the Twenty-First Century

Approved by:

\_\_\_\_\_  
Stephen A. Bourque, Ph.D. Monograph Director

\_\_\_\_\_  
Michael A. Hochwart, COL, German Army Monograph Reader

\_\_\_\_\_  
Christopher R. Farley, COL, LG Monograph Reader

\_\_\_\_\_  
Stefan Banach, COL, IN Director,  
School of Advanced  
Military Studies

\_\_\_\_\_  
Robert F. Baumann, Ph.D. Director,  
Graduate Degree  
Programs

Disclaimer: Opinions, conclusions, and recommendations expressed or implied within are solely those of the author, and do not represent the views of the US Army School of Advanced Military Studies, the US Army Command and General Staff College, the United States Army, the Department of Defense, or any other US government agency. Cleared for public release: distribution unlimited.

## **Abstract**

SUSTAINING OPERATIONAL MANEUVER IN THE TWENTY-FIRST CENTURY by Major Justin S. Herbermann, U.S. Army, 98 pages.

The purpose of this monograph is to determine if the United States Army can sustain operational maneuver in the twenty-first century. The author determined that the army can sustain operational maneuver but still needs to address four areas. First, there are issues regarding the operational level logistics system (primarily command and control and command support relationships). Second, there is a lack of logistics support at the divisional level. Third, the army has an inordinate focus on short, decisive battles rather than on long campaigns. Finally, some minor issues still exist at the tactical level of logistics which the army needs to analyze.

The author employed a case study method in this monograph which analyzed three operations. These campaigns involved extensive operational maneuver against an entrenched enemy who lacked air supremacy. The 1<sup>st</sup> Infantry Division was the common element in each campaign. First, the author analyzed Operation COBRA during the Normandy Campaign in 1944. Next, the author reviewed Operation DESERT STORM in 1991. Finally, the author created a notional case study--Operation GREEN DAWN--war in Iraq against Iran in 2012. The author further subdivided each case study into sections which covered the divisional or brigade structure; combat operations; strategic and operational level logistics; tactical level logistics; and the results of logistics support based around the '35MM' model (fuel, ammunition, maintenance, and medical support). The first two case studies offer historical lessons learned regarding sustaining operational maneuver. The last case study addresses how the U.S. Army would sustain operational maneuver in the near future in a realistic scenario.

The author concluded by analyzing all three campaigns based on the principles of sustainment. These findings and the results of each section determined that the army can sustain operational maneuver in the twenty-first century. The author posited a list of recommendations at the operational levels of logistics. These improvements to the logistics architecture would aid the army in sustaining operational maneuver in the twenty-first century.

# TABLE OF CONTENTS

INTRODUCTION.....	1
CASE STUDY - OPERATION COBRA.....	8
Strategic and operational levels of war.....	9
Combat operations.....	10
Operational level doctrine: Army, Corps, Division, & Depot.....	13
Tactical level doctrine: 35MM.....	17
Doctrine & the results: what should have happened and what happened.....	24
CASE STUDY--OPERATION DESERT STORM.....	30
Strategic and operational levels of war.....	30
Combat operations.....	32
Operational level doctrine: SUPCOM / COSCOM / CSG / DISCOM.....	36
Tactical level doctrine: 35MM.....	42
Doctrine & results: what should have happened and what happened.....	47
CASE STUDY – OPERATION GREEN DAWN.....	51
Strategic and operational levels of war.....	51
Combat operations.....	53
Operational level doctrine: TSC / ESC / Sustainment Brigade.....	55
Tactical level doctrine: 35MM.....	58
Results: what should have happened and what happened.....	63
CONCLUSION.....	67
The principles of sustainment.....	68
Success at the tactical level.....	74
Recommendations for the operational level.....	78
Concluding comments.....	81
APPENDICES.....	82
Appendix A: Table B-2 Command and Support Relationships.....	82
Appendix B – Table B-3: Army Support Relationships.....	83
Appendix C – Map of 1 <sup>st</sup> ID (COBRA).....	84
Appendix D – TO&E for new Infantry Division (July 1943).....	85
Appendix E – Task Organization of 1 <sup>st</sup> ID (COBRA).....	86
Appendix F – Photograph of army supply depot.....	87
Appendix G – Task Organization for 1 <sup>st</sup> ID (DESERT STORM).....	88
Appendix H – Map of Operation DESERT STORM.....	89
Appendix I--Task Organization for Heavy Brigade Combat Team.....	90
Appendix J– Operation GREEN DAWN Logistics Results.....	91
POL CONSUMPTION DATA.....	91
AMMUNITION CONSUMPTION DATA.....	92
MAINTENANCE DATA.....	93
MEDICAL DATA.....	94
BIBLIOGRAPHY.....	95

## INTRODUCTION

Blasting past the remnants of the *Panzer Lehr Division*, the motorized 1<sup>st</sup> Infantry Division with its truck mounted soldiers finally broke into open ground and out of the hedgerows while exploiting the breach created by strategic bombers and the other divisions of the United States Army VII Corps. Maneuver operations would now be the hallmark of the campaign as the bloody attrition fighting following D-Day came to an end with the launch of Operation COBRA. In five days, the division fought and maneuvered forty miles from St. Lo to outside Mortain defeating three German divisions in the process.<sup>1</sup> Forty seven years later, the Big Red One was again on the move. Again part of the U.S. Army VII Corps, the division was now a mechanized one: armed with M1 Abrams tanks and M2/3 Bradley infantry fighting vehicles. Beginning at 1500 hours on February 24, the armored vehicles of 1<sup>st</sup> Infantry Division roared into the Iraqi berm with two brigades abreast and a third trailing.<sup>2</sup> Five days later the battle ended after the division had maneuvered more than 250 km and defeated the Iraqi 26<sup>th</sup> *Infantry Division* and the *Tawakalna Division*.<sup>3</sup> In both cases, the 1<sup>st</sup> Infantry Division had to conduct operational maneuver over a great distance to fight the enemy force.

Both examples illustrate the ability of combat service support units to provide the fuel, ammunition, maintenance, and medical support needed by fighting units on the

---

<sup>1</sup>Martin Blumenson, *Breakout and Pursuit* (Washington, D.C.: Center of Military History, 1984), 253-263.

<sup>2</sup>Stephen A. Bourque, *Jayhawk! The VII Corps in the Persian Gulf War* (Washington, D.C.: Department of the Army, 2002), 224.

<sup>3</sup>*Ibid.*, 344.

move.<sup>4</sup> In 2010, the United States Army's current logistics architecture<sup>5</sup> supporting a modern heavy brigade combat team within a division or corps may not be capable of adequately sustaining mechanized maneuver warfare during major combat operations because of a lack of integration and synchronization between operational level logistics and tactical level logistics. Operational level logistics focuses on supporting campaigns and major operations while simultaneously establishing and lengthening the commander's operational reach. Tactical level logistics involves providing sustainment to brigades and battalions within a more finite time period (usually 72-96 hours).<sup>6</sup>

In the early twenty-first century, the U.S. Army transformed its logistics structure at the tactical and operational level. While on the surface, it appears that there are more assets to support combat units within a brigade combat team, there also seems to be confusion between tactical logistics and operational logistics. The theater sustainment command has replaced the corps support command but neither the division commander nor the corps commander controls his own logistics units.<sup>7</sup> There is no longer a division support command with a main support battalion to provide reinforcing logistical support

---

<sup>4</sup>Joint Publication 1-02: *Department of Defense Dictionary of Military and Associated Terms* (Washington, D.C.: U.S. Government Printing Press, 2007), 99. Joint doctrine defines CSS as the essential capabilities, functions, activities, and tasks necessary to sustain all elements of operating forces in theater at all levels of war.

<sup>5</sup>I define the logistics architecture as a nodal system with the nodes being logistics units and key logisticians and the paths between the nodes being the interfaces between and among those units and individuals.

<sup>6</sup>CGSC, *Sustainment in the Theater of War* (Ft. Leavenworth: U.S. Army CGSC, 2007), 1-10 – 1-11.

<sup>7</sup>*Ibid.*, 2-8. The COSCOM was the assigned logistics structure supporting a corps while the DISCOM was the assigned logistics structure supporting a division. See the section on DESERT STORM for more detailed information. See the section on GREEN DAWN for more information regarding the TSC.

to a divisional brigade combat team.<sup>8</sup> This change also leaves the senior logistician within the division as the G4, a lieutenant colonel, versus the traditional division support commander, a colonel. As a result of these organizational changes, can the United States Army of the second decade of the twenty-first century sustain operational maneuver similar to those described at the opening of this monograph?

In the union between tactical and operational level logistics, there are four main reasons why the army's sustainment architecture may be inadequate and incorporate unnecessary risk to major combat operations. Doctrine is the common linkages amongst all four.<sup>9</sup> First, our current doctrine fails to clearly differentiate command and support relationships at the operational level of logistics, i.e. between sustainment brigades, expeditionary sustainment commands, and division headquarters. There are non-doctrinal concepts still in use. Second, there is now a lack of logistics support at the division level. Third, there is an inordinate focus on the short, decisive battle. Current planners expect operations to last a period of three to five days and operations of longer duration such as pursuits and exploitations are not the basis of training proficiency or equipment capabilities. Finally, there exists a problem of organizational structure at the tactical level. As in the case of the Vietnam War, the U.S. Army has had to overly compensate on current, small war, combat operations in Iraq and Afghanistan at the expense of skills,

---

<sup>8</sup>Field Manual 3-0: *Operations* (Washington, D.C.: Department of the Army, 2008), C-6. "As combined arms organizations, BCTs form the basic building block of the Army's tactical formations. They are the principle means of executing engagements."

<sup>9</sup>*Department of Defense Dictionary of Military and Associated Terms*, 166. The military defines doctrine as the fundamental principles by which the military forces or elements thereof guide their actions in support of national objectives. It is authoritative but requires judgment in application.



equipment, training, and doctrine for major combat operations.<sup>10</sup> To validate this thesis, this manuscript examines each of the two incidents described at the opening of this essay against the standards of doctrine, capability, tactical focus, and structure at the operational and tactical level. These operations bear similarities not just in the distances covered (between 25-50 miles) but also in the time of the operation (about four days or 100 hours) as well as the fact that there was little to no enemy air presence to interdict operations. Additionally, these operations started with a significant base of support already established in theater – neither was conducting forced entry operations.

The operational level of war links tactics to strategy. “Operational art determines when, where, and for what purpose commanders employ major forces.”<sup>11</sup> Commanders conduct campaigns and major operations at the operational level of war. The former is a “series of related major operations aimed at achieving strategic and operational objectives within a given space and time” while the latter is “a series of tactical actions conducted by combat forces of a single or several services, coordinated in time and place, to achieve strategic or operational objectives in an operational area.”<sup>12</sup> The 1991 Persian Gulf War is an example of a campaign (Operations DESERT SHIELD and DESERT STORM) while Operation COBRA is an example of a major operation. Both employed elements of operational art and used operational maneuver. Operational maneuver involves the deployment of ground forces to locations that enable joint forces offensive operations.<sup>13</sup>

---

<sup>10</sup>Robert M. Citino, *Blitzkrieg to Desert Storm* (Lawrence: University Press of Kansas, 2004), 254-264.

<sup>11</sup>*Operations*, 6-3.

<sup>12</sup> *Ibid.*, 6-3.

<sup>13</sup>*Operations*, 3-8.

At both the operational and tactical levels of war, offensive operations, a part of full spectrum operations, include four primary tasks: movement to contact, attack, exploitation, and pursuit.<sup>14</sup> Often army planners focus on the first two and do not generate appropriate branch and sequel plans for the latter two.<sup>15</sup> According to Field Manual (FM) 3-0 *Operations*, “an exploitation rapidly follows a successful attack and disorganizes the enemy in depth.”<sup>16</sup> Division and higher headquarters conduct exploitation in order to turn it into a pursuit. Speed and decentralized control are the hallmarks of pursuit operations. “A pursuit is designed to catch or cut off a hostile force attempting to escape with the aim of destroying it.”<sup>17</sup> As elements of maneuver at the operational level, operational reach and culminating points limit the extent of exploitation and pursuit.<sup>18</sup> Logistics planners at the operational level assist in determining operational reach and preventing culmination.

According to current doctrine, the theater sustainment command (TSC) manages operational level logistics. This is the single headquarters responsible for army logistics in a theater. This command may employ an expeditionary sustainment command which provides forward command and control for logistics forces.<sup>19</sup> There is some overlap and

---

<sup>14</sup>Ibid., 3-1. The army’s operational concept is full spectrum operations. Army forces combine offensive, defensive, and stability or civil support operations simultaneously as part of an interdependent joint force to seize, retain, and exploit the initiative, accepting prudent risk to create opportunities to achieve decisive results.

<sup>15</sup>From the author’s class discussion with fellow students.

<sup>16</sup>*Operations*, 3-8 – 3-9

<sup>17</sup>Ibid.

<sup>18</sup>Field Manual 3-0: *Operations* defines operational reach as the distance and duration across which a unit can successfully employ military capabilities (paragraph 6-74) and culminating point as that point in time in which a force no longer possesses the capability to continue its current form of operations (paragraph 6-94).

<sup>19</sup>Field Manual Interim 4-93.2: *The Sustainment Brigade* (Washington, D.C.: U.S. Government

some distinction between the operational and tactical levels of logistics. At both levels, “sustainment is provided by highly trained modular sustainment forces, integrated and synchronized with the operational plan.”<sup>20</sup> The sustainment brigade is that flexible, modular organization. It can have operational level responsibilities, e.g. provide operational sustainment, conduct theater opening, or provide theater distribution or tactical level responsibilities, e.g. provide general support to a division.<sup>21</sup> One tool to assist operational level logisticians is the operational logistics planner: a web based interactive tool used to develop a logistics estimate for multi-phase operations.<sup>22</sup>

In the early twenty-first century, the term sustainment has come into the vernacular. While often considered synonymous with logistics, according to FM 3-0 *Operations*, sustainment is the provision of the logistics, personnel services, and health service support necessary to maintain operations until mission accomplishment while logistics is the science of planning and carrying out the movement and maintenance of forces. Now it is more common to use logistics when referring to maintenance, transportation, supply, field services, distribution, contracting, and general engineering support.<sup>23</sup> While it would be anachronistic to use the term sustainment to refer to Operations COBRA or DESERT STORM, the concepts and principles of sustainment are relevant for any time period.

---

Printing Press, 2009), 1-3 – 1-4.

<sup>20</sup>Field Manual 4-0: *Sustainment* (Washington, D.C. U.S. Government Printing Press, 2009), 1-1.

<sup>21</sup>*The Sustainment Brigade*, 2-1.

<sup>22</sup>*Sustainment*, 4-2.

<sup>23</sup>*Operations*, 4-5.

According to Table B-2 of Field Manual 3-0, *Operations*, there are five types of command relationships. All organic forces organized under a headquarters have an organic relationship with that headquarters. This is the most fixed command relationship. A higher headquarters does not normally separate assigned units such as these from their parent unit. An attached unit is one that has a command relationship with its gaining unit. Normally a headquarters would receive an attachment for a certain operation or time period; an attached unit has its priorities established by the gaining unit. A unit under operational control (OPCON) is similar to an attached unit except that its administrative support remains with its original parent unit; the gaining commander can task organize an OPCON unit (just like an attached unit). However, a gaining commander cannot task organize a unit under tactical control (TACON) unit (the last type of command relationship). OPCON and TACON relationships normally only last for a few days or for a specific mission, or are based on METT-TC.<sup>24</sup>

According to Table B-3 of Field Manual 3-0, there are four types of army support relationships. Support relationships allow the supporting commander to use his or her units' abilities and resources to support the requirements of the supported commander. A unit in direct support (DS) is positioned by the unit that it is supporting and has priorities established by that same unit. The second support relationship is reinforcing (R); this can only be between like type units. A unit that is reinforcing another is positioned by its reinforced unit and has priorities set by that unit. The third relationship is general support

---

<sup>24</sup>*Operations*, B-10. Regarding joint doctrine and higher level units, the military considers a unit "assigned" if it has a command relationship with a combatant command. It has its priorities established by the Army Service Component Command. METT-TC: Mission, Enemy, Time, Troops, Terrain, Civilian Considerations. See Appendix A for a more detailed chart.

reinforcing (GSR). Similar to reinforcing support, it first has its priorities set by the parent unit then by the reinforced unit. Finally, a unit can be in general support (GS). It is positioned by its parent unit and has its priorities set by its parent unit also.<sup>25</sup>

Can the twenty-first century United States Army sustain operational maneuver? Examining Operation COBRA and the breakthrough by the 1<sup>st</sup> Infantry Division of the U.S. Army VII Corps in 1944, the same unit again during 1991 in Operation DESERT STORM against the Iraqi Republican Guard will allow the reader to understand the four main problems merging operational and tactical logistics. Then we will consider a notional case study in Iraq today where the modular 1<sup>st</sup> Infantry Division responds to an invasion by the Iranian Army. After comparing these events, this monograph identifies relevant lessons from these case studies and provides recommendations for future sustainment and organization.

## **CASE STUDY - OPERATION COBRA**

On D-Day, June 6, 1944, the Allies cracked Hitler's Fortress Europe. Victory for the Allied strategy in the Second World War was in sight. Then, after the first few days, the advance of the Twenty-First Army Group (the overall land component command) slowed down. In the eastern sector, Field Marshall Bernard Law Montgomery and the Commonwealth forces launched Operation GOODWOOD in an attempt to break through the German lines. In the western sector attacking American forces encountered the difficult hedgerow obstacles and a tenacious German enemy adapt at defending them. The allied forces lost momentum and needed to break out.<sup>26</sup>

---

<sup>25</sup>*Operations*, B-11. See Appendix B for a more detailed chart.

<sup>26</sup>Russell F. Weigley, "Normandy to Falaise: A Critique of Allied Operational Planning in 1944,"

## Strategic and operational levels of war

To break through this sector, General Omar Bradley directed the development of Operation COBRA to penetrate the German lines and break through the Normandy hedgerow country.<sup>27</sup> For the American forces, it was the transition between the bloody, slow attritional fighting in the Normandy hedgerows and the massive exploitation and pursuit of the German army across the French countryside in the late summer and early fall of 1944. Operation COBRA was an example of combined arms operations--in particular fire and maneuver--at the operational level of war. The United States First Army, the American component of Twenty-First Army Group (until the Twelfth Army Group became operational) demonstrated that American planners had finally become masters of operational art.<sup>28</sup>

To paraphrase a recent Secretary of Defense, one goes to war with the divisions you have. In July 1943 the War Department published the final infantry division table of organization and equipment.<sup>29</sup> The authorized end strength of the 1<sup>st</sup> Infantry Division during World War II was 14,037 soldiers with three infantry regiments, three artillery battalions, an engineer battalion, a reconnaissance company, and various combat support and combat service support units.<sup>30</sup>

The 1<sup>st</sup> Infantry Division was unique during Operation COBRA--it was now a motorized division. General Bradley's First Army attached seven truck companies to haul

---

in *Historical Perspectives of the Operational Art*, ed. By Michael D. Krause and R. Cody Phillips, (Washington, D.C.: Center of Military History, 2007), 393-403.

<sup>27</sup>See Appendix C for map of operation.

<sup>28</sup>Ibid., 393-403.

<sup>29</sup>John Sayen, *US Army Infantry Divisions, 1944-45* (Oxford: Osprey Publishing, 2007), 9.

<sup>30</sup>Sayen, 7. See Appendix D for TO&E chart.

personnel and one to carry ammunition.<sup>31</sup> The division's assigned units were the 16<sup>th</sup>, 18<sup>th</sup>, and 26<sup>th</sup> Infantry Regiments, three battalions of field artillery, and other special troops.<sup>32</sup> Each infantry regiment consisted of a headquarters company, a service company, a medical detachment, a canon company, an anti-tank company, and its main fighting power: three infantry battalions each with three rifle companies, a heavy weapons company, and a headquarters company.<sup>33</sup> For Operation COBRA the division received a logistical slice from the American First Army as well as additional combat arms units from the VII Corps such as Combat Command B, the 745<sup>th</sup> Tank Battalion, and another artillery battalion.<sup>34</sup> This created a powerful, very mobile, fighting force.<sup>35</sup>

### **Combat operations**

Bradley's plan called for three corps to attack the German front and open a penetration. The VII Corps, commanded by Lieutenant General J. Lawton Collins was to break through the German lines with three divisions (9<sup>th</sup> Infantry, 4<sup>th</sup> Infantry, and 30<sup>th</sup> Infantry) following a massive bombardment by heavy bombers. Then 1<sup>st</sup> Infantry Division (motorized for the attack) along with the attached Combat Command B of 3<sup>rd</sup>

---

<sup>31</sup>*After Action Report, G4 Section: JUN 44-DEC 44 & DEC 45* (1<sup>st</sup> Infantry Division: G4 Section, 1945), 25. It is important to note that the report stated that these truck companies were attached not OPCON or just providing Area Support. Kent Roberts Greenfield, *The Army Ground Forces: The Organization of Ground Combat Troops* (Washington, D.C.: U.S. Government Printing Press, 1947), 338. There would be 336 vehicles for 7 companies.

<sup>32</sup>H. R. Knickerbocker, *Danger Forward: The Story of the First Division in World War II* (Atlanta: Albert Love Enterprises, 1947) 414-427. Common vernacular considered each infantry regiment a regimental combat team (RCT).

<sup>33</sup>Peter R. Mansoor, *The GI Offensive in Europe: The Triumph of American Infantry Divisions* (Lawrence: University of Kansas Press, 1999), 38.

<sup>34</sup>A slice is a non doctrinal but commonly used term. It refers to unassigned assets that habitually support a unit.

<sup>35</sup>See Appendix E for 1<sup>st</sup> Infantry Division Task Organization as of July 1944.

Armored Division was to attack through this gap to the town of Coutances. The 3<sup>rd</sup> Armored Division was to make a wide envelopment and the 2<sup>nd</sup> Armored Division was to make an even wider envelopment by attacking to the Sienne River and establishing blocking positions along the way.<sup>36</sup> They would be facing the German *Seventh Army* comprised of the *LXXXIV Corps* (weakened elements of eight divisions) and the *II Parachute Corps* (elements of two divisions).<sup>37</sup>

Preceded by a massive aerial bombardment, the VII Corps attack began on July 25. The 1<sup>st</sup> Infantry Division followed the penetration on July 26. Major General Clarence Huebner, the division commander, initially had a complicated plan involving a series of passages of lines but because the 9<sup>th</sup> Infantry Division attack bogged down, the VII Corps tasked 1<sup>st</sup> Infantry Division with the objective of taking the town of Marigny and opening the gap in the enemy lines. The 18<sup>th</sup> Regiment and Combat Command B attacked abreast at 0700 hours against the *Panzer Lehr Division* while the 16<sup>th</sup> and 26<sup>th</sup> Regiments followed in reserve. The division successfully passed through 9<sup>th</sup> Infantry Division and battled or mopped up pockets of German resistance. One major challenge was that the craters from the carpet bombing had cut the road to Marigny in twenty-five places. Throughout the day, the division made slow and steady progress towards the objective despite German counter-attacks by the 275<sup>th</sup> and 353<sup>rd</sup> Divisions. By dusk however, Combat Command B stopped their attack outside the town of Marigny while the 18<sup>th</sup> Regiment, on the false report that American tanks were in the town, skirted the town but did not yet seize their objective above it. Interestingly, the artillerymen only

---

<sup>36</sup>Blumenson, 218.

<sup>37</sup>Ibid., 227.



fired eight missions that day--a respite from the massive pre-offensive bombardment in which they participated.<sup>38</sup>

The second day, July 27, was more auspicious. The attack resumed with the 18<sup>th</sup> Regiment moving towards Marigny at 0600 hours. They battled through the town all day and did not link up with Combat Command B until 2300 hours. On the right flank, the 16<sup>th</sup> Regiment and the 4<sup>th</sup> Cavalry Squadron attacked towards the Marigny-St. Sauveur – Lendelin road. Meanwhile, Combat Command B found the first open ground in the operation and reached the division's first objective in the late afternoon; however, they were critically short of fuel and ammunition. After dark, a resupply convoy escorted by military police and a medium tank company finally reached them.<sup>39</sup>

By dawn on the third day (July 28), the 16<sup>th</sup> Regiment reached the town of La Chapelle and strengthened the VII Corps envelopment.<sup>40</sup> This was probably the most critical day of the offensive and the Germans fought desperately. According to Knickerbocker, "The necessity for speed and still more speed, time and still more time, had not abated. A position on the high ground had to be held so that the jaws of the vice could squeeze on the Germans remaining in the pocket."<sup>41</sup> The 1<sup>st</sup> Infantry Division finally sealed the envelopment by 2015 hours. The 26<sup>th</sup> Regiment reported that it had

---

<sup>38</sup>James Jay Carafano, *After D-Day: Operation Cobra and the Normandy Breakout* (Boulder: Lynne Rienner Publishers, Inc., 2007), 191-203.

<sup>39</sup>Ibid., 203-207. The roads were extremely congested.

<sup>40</sup>Ibid., 207.

<sup>41</sup>Knickerbocker, 233.

made contact with both the 90<sup>th</sup> and 83<sup>rd</sup> Infantry Divisions to the north and the 9<sup>th</sup> Infantry Division to the east.<sup>42</sup>

The last day of the offensive, July 29, found the momentum of the VII Corps' attack increasing. By evening, 1<sup>st</sup> Infantry Division had eliminated German resistance south of the Soule River. General Collins came to the division command post and told them, "we have achieved a great victory."<sup>43</sup> The division had widened the gap in the German lines and assisted in enveloping significant enemy forces. The hedgerow fighting was over and the division had finally entered a war of movement. Operation COBRA had accomplished its objectives. The American offensive broke through the German front line and allowed a sizeable gap for General George S. Patton's recently reorganized Third Army to pass through the penetration and begin and exploitation into the German rear area.

### **Operational level doctrine: Army, Corps, Division, & Depot**

The United States Army's main combined arms headquarters during World War II was the division.<sup>44</sup> There were basically two types of divisions--infantry and armored.<sup>45</sup> Lieutenant General Leslie McNair and the War Department reorganized the infantry division in an attempt to make it 'leaner' by reducing the number of non-infantry

---

<sup>42</sup>*G3 Report of Operations, 1- 31 July* (1<sup>st</sup> Infantry Division: G3, 1944), 25.

<sup>43</sup>*Ibid.*, 28.

<sup>44</sup>War Department, *Field Manual 100-5: Operations* (Washington, D.C.: War Department, 1944), 4. Although one could consider the regiment with organic cannon company and service company almost a combined arms team, the division could truly command infantry, armor, artillery, engineer, and reconnaissance units all at once as well as provide them logistical support.

<sup>45</sup>Greenfield, 336. Other types included airborne, cavalry, jungle, light, mountain, and motorized.

personnel and equipment.<sup>46</sup> His reasons for this were primarily two-fold. First he wanted to have the maximum amount of combat power as possible in combat arms units available to confront the enemy (with little or no idleness of units or personnel). Second, there was a finite amount of shipping available to transport American units and supplies to the theaters of war. By reducing the ratio of combat to support personnel in the division, he intended to sever logistics links between the division and corps and to lighten the respective headquarters and assign the main administrative and logistical units to field armies.<sup>47</sup>

These concerns--the tooth to tail ratio in forces and the ability to expeditiously deploy units as fast as possible have continued to challenge the U.S. Army through every era including the present. During World War II, the corps headquarters was a 'combat agency' unless it was a separate corps whereas the army headquarters was both a 'combat agency' and an 'administrative agency.' Except in extreme circumstances, the army usually bypassed the corps (sometimes even the divisions) with administrative and supply issues and went directly to the division or regiment.<sup>48</sup> Although leaders put Lieutenant General McNair's ideas in place, there was lots of disagreement from the field.<sup>49</sup> In reviewing combat conditions in Europe, historians in the Office of the Quartermaster General William Ross and Charles Romanus noticed that "by his criteria, one or another

---

<sup>46</sup>Lieut. Gen. McNair was the commander of Army Ground Forces and was killed during Operation COBRA.

<sup>47</sup>Greenfield, 273.

<sup>48</sup>Greenfield, 365.

<sup>49</sup>Ibid., 276. "Disagreement arose in the judgment of concrete cases."

of the American armies was experiencing an ‘emergency’ during at least nine months of the eleven month European campaign.”<sup>50</sup>

Supply depots were the organizations forming the heart of operational level logistics. The depot system concept worked well on a linear battlefield. The rapid advance, like during and after Operation COBRA, strained the system. The army’s system of depots (also known as supply points or distribution points in the European Theater) developed from the new families of trucks as well as the overall motorization process of the army during the late 1930s and early 1940s. The new trucks rather than animal transport allowed the logistics systems to bypass the corps and deliver down to the divisions and in some cases to the regiments.<sup>51</sup> The army designed the depots to move every four days to keep pace with the advance of forces. Normally they would leapfrog forward with a rear echelon remaining to handle the remaining large quantities of supplies.<sup>52</sup> The depot system did not function as well as planned for three reasons. First, the base depots did not work fast enough nor well enough to keep the ports cleared. Second, to alleviate the first problem they lost adequate inventory control. Stocks were unloaded from ships and dumped in large warehouses without being adequately inventoried and recorded. In the case of the depot at Antwerp, it became quicker for a unit to order a new item from the United States than have supply officers search through the mountains of supplies in the warehouses. Third, there was never truly an effective system of intermediate depots established to leapfrog forward to support the advancing

---

<sup>50</sup>William F. Ross and Charles F. Romanus, *The Quartermaster Corps: Operations in the War against Germany* (Washington, D.C.: Office of the Chief of Military History, 1965), 482.

<sup>51</sup>Sayen, 47.

<sup>52</sup>Carafano, 60.

front.<sup>53</sup> The depots were basically a series of fixed giant warehouses rather than agile, moving supply points.<sup>54</sup>

By the end of July 1944, the United States First Army had established its own fuel supply depot. The First Army would send daily telegrams to Advance Section of the Communication Zone, usually referred to as the COMZ, identifying the type and amount of fuel to push forward. In turn, trucks delivered this fuel to the First Army supply point.<sup>55</sup> From there logisticians distributed fuel down to the divisional supply points. The final leg of this distribution was via five-gallon gas cans, called by most GIs ‘Jerry Cans’ because the Germans developed them to support their armored movement early in the war.<sup>56</sup> Prior to the invasion the policy on fuel exchange was one empty for one full can. As can be imagined, this system broke down during the breakout and pursuit across France. There was no time to exchange cans. By the middle of October there were an estimated 3.5 million cans missing across the theater and they became a critical shortage.<sup>57</sup> This system itself, a ‘pull’ system using written requirements submitted from supported units, further taxed the logistics architecture.<sup>58</sup> Eventually logisticians learned to anticipate requirements and then ‘push’ fuel based on their commander’s priorities.<sup>59</sup>

---

<sup>53</sup>James A. Huston, *The Sineews of War: Army Logistics 1775-1953* (Washington, D.C.: Office of the Chief of Military History, 1966), 533.

<sup>54</sup>See the Appendix F for a photograph of one of the depots from *48 Million Tons to Eisenhower*.

<sup>55</sup>Eudora Ramsay Richardson and Allan Sherman, *Fuels and Lubricants, Volume IV: Quartermaster Supply in the ETO* (Camp Lee: The Quartermaster School, 1948), 41.

<sup>56</sup>Carafano, 60. He states that the design was “allegedly” from the Germans.

<sup>57</sup>Richardson and Sherman, 33.

<sup>58</sup>This is probably an anachronistic term. I believe logisticians did not identify the idea of the push – pull concept of logistics until later.

<sup>59</sup>Carafano, 60.

Logistics units from the field army would directly augment a division to provide added support since the divisions did not have enough assets to accomplish their sustainment missions. There simply were not enough quartermaster soldiers to do everything.<sup>60</sup> In addition to attaching troops directly to the divisional quartermaster company, there were whole companies added to divisions. Although the army assigned these units to an army headquarters, they were part of the Army Service Forces. Lieutenant General Brehon Somervell, the commander of the Army Service Forces, felt that “all supply and service functions not so organic to combat units should be performed by a common service agency.”<sup>61</sup> The attached companies could have been various types of truck companies, maintenance companies, ordnance companies, or quartermaster companies.

### **Tactical level doctrine: 35MM**

Three key aspects of organic support to the infantry regiment were the service company, the medical detachment, and the logistical train concept. The service company provided direct logistics support to the regiment and was sub-divided into a headquarters platoon and a transportation platoon. The latter’s platoon leader was also the regimental motor officer. Each transportation platoon had a section designated to support each battalion. Those section leaders were also their respective battalion supply officers.<sup>62</sup> The

---

<sup>60</sup>Ross and Romanus, 472.

<sup>61</sup>John D. Millet, *The Organization and Role of the Army Service Forces* (Washington, D.C.: Center of Military History), 438. This was in a memo signed by the ASF, AGF, and AAF commanders. This almost sounds like the Army Sustainment Command (ASC) of today except that I do not believe there is a command link between the ASC and the TSC’s. The latter should be COCOM to a GCC.

<sup>62</sup>Field Manual 7-30: *Infantry Supply and Evacuation* (Washington, D.C.: War Department, 1944), 91-101.

medical detachment provided direct medical support and care to the regiment. It was subdivided into the regimental aid station and three battalion aid stations.<sup>63</sup> The regimental train concept was the organization of logistics for movement, maneuver, and sustainment of the regiment. Operating personnel and vehicles from the service company and medical detachment subdivided into four types of trains based on their function: ammunition, kitchen and baggage, maintenance, and medical. Often these trains would further sub-divide to support each of the battalions and separate companies.<sup>64</sup>

Fuel support, known as petroleum, oil, and lubricants (POL or Class III in the U.S. Army's classes of supply) is always in more demand during offensive operations. The division G4 was responsible for identifying fuel supply points. Since there were no organic fuel trucks within a division, these supply points had to have been within 35 miles of the unit area.<sup>65</sup> Units would receive fuel via five-gallon cans. Armored divisions, because of their tanks and additional vehicles, normally needed one additional attached quartermaster company (gasoline supply) to operate the division fuel point.<sup>66</sup> Infantry divisions had only one divisional quartermaster company which provided all classes of supply to the division except, usually, for Class V. A typical company consisted of three truck platoons and a service platoon.<sup>67</sup> The divisional truck platoons would travel to the

---

<sup>63</sup>Ibid., 119-120.

<sup>64</sup>Ibid., 103-104.

<sup>65</sup>Field Manual 17-50: *Field Service Regulations: Logistics* (Washington, D.C.: War Department, 1942), 61.

<sup>66</sup>*Field Service Regulations: Logistics*, 62. There were both 5 gallon drums and 5 gallon cans: the drum being the earlier American version, the can being the latter model "jerry" can.

<sup>67</sup> Benjamin J. King, Richard C. Biggs, and Eric C. Criner, *Spearhead of Logistics: A History of the United States Army Transportation Corps* (Ft. Eustis: U.S. Army Transportation Center, 1994), 121-123. The War Department officially created the Transportation Corps on 31 July 1942; however, many truck units did not change their designation from quartermaster until 1946.

Army truck head, pick up supplies, and drop them at the divisional distribution point. The service platoon manned this location.<sup>68</sup> At that point, trucks from the regimental service company would pick up the supplies and deliver them to the regiment's battalions and separate companies. A typical division in maneuver warfare required or consumed about 300-350 tons of supplies per day. The division quartermaster company would directly handle most of this tonnage.<sup>69</sup>

Logisticians distributed ammunition, Class V in the army system, in a slightly different manner. Unlike fuel which had a 'middleman' in the form of the divisional quartermaster company, the regiments went directly to the army supply points for ammunition. A regiment would receive credits for an operation then use them to draw ammunition from the army-level supply point.<sup>70</sup> Then it would report what it had drawn to the division ordnance officer.<sup>71</sup> Designated weapons carrier vehicles at the regiment and battalion level carried reserve ammunition for use in an emergency. The system was challenging because it was a pull system requiring the quick delivery of unpredictable amounts of ammunition.<sup>72</sup> Also, there were no standard containers such as twenty foot mil-vans that exist today.

Infantry divisions had one ordnance light maintenance company to conduct maintenance activities. It was comprised of three platoons – automotive, armament, and

---

<sup>68</sup>Ross and Romanus, 471-472.

<sup>69</sup>Martin Van Creveld, *Supplying War: Logistics from Wallenstein to Patton* (Cambridge: Cambridge University Press, 1977), 215.

<sup>70</sup>Sayen, 50. "A credit was a specified amount of ammunition for a specified unit at a specified ASP for a specified period of time."

<sup>71</sup>*Infantry Supply and Evacuation*, 39-40.

<sup>72</sup>Sayen, 49.



supply; however, ten percent of the company was part of the division ordnance section on the division staff.<sup>73</sup> There were four main levels of maintenance. The driver or operator conducted first echelon maintenance. The service company performed second echelon maintenance. The divisional maintenance company conducted third echelon maintenance while higher level companies at the corps and army levels performed fourth echelon maintenance.<sup>74</sup> The key to the first two levels was that no combat organization should conduct maintenance which could last more than six hours.<sup>75</sup> If it were to take longer, mechanics were supposed to evacuate the item/vehicle to the next higher level. There was field maintenance but it referred more to the location of activity rather than how we define levels of maintenance today.<sup>76</sup> Bluntly, the system was inadequate. To balance General McNair's limitations on the number of personnel, the War Department authorized second-echelon mechanics to conduct third-echelon repairs. The divisional maintenance companies themselves could only perform about one-third the number of jobs evacuated to them. Thus, many divisions requested an attachment of an additional maintenance company for repairs.<sup>77</sup>

The last logistical element at the division level was the medical battalion. Together with the division surgeon's office, this unit was the foundation for medical support to the division. Interestingly, the division surgeon was also the commander of the medical battalion. The battalion contained a headquarters company, three collecting

---

<sup>73</sup>Ibid., 24.

<sup>74</sup>*Infantry Supply and Evacuation*, 56-57.

<sup>75</sup> *Field Service Regulations: Logistics*, 91.

<sup>76</sup>See section on Operation GREEN DAWN for a discussion of the current levels of maintenance.

<sup>77</sup>Sayen, 53.

companies, and one clearing company.<sup>78</sup> The collecting companies' ambulance platoons provide motor ambulances down to the regimental level to evacuate casualties.<sup>79</sup> Besides the ambulance platoons, this collecting company would normally have a habitual relationship with each regiment and could provide ten four-man litter teams as well as run an intermediate aid station. Each of these aid stations was a mini-hospital. The medical system shipped patients requiring greater care to corps, army, or state-side hospitals.<sup>80</sup> The division could also receive additional medical units as attachments.

The divisional artillery had a slightly different logistical system than the infantry regiments. Each battalion had its own service battery. This small battery of less than 80 Soldiers had three elements: an ammunition platoon, a service platoon, and a maintenance section. In continuing the multiple duties trend, the battery commander was also the battalion S4.<sup>81</sup> The main difference between artillery and infantry Class V, apart from the size, was that instead of a regimental service company sending trucks to an army supply point, the battalion service battery sent them.<sup>82</sup> One contemporary issue which concerned artillerymen appeared to be the reporting requirements to the division G4 ammunition office: "The insertion of the division ammunition office in artillery ammunition supply procedure has thrown a monkey wrench of annoying

---

<sup>78</sup>Field Manual 8-10: *Medical Service of Field Units* (Washington, D.C.: War Department, 1942), 28-30.

<sup>79</sup>*Infantry Supply and Evacuation*, 74.

<sup>80</sup>Sayen, 52.

<sup>81</sup>Sayen, 20.

<sup>82</sup>*Ibid.*, 50.

proportions...under all cases so far examined the division ammunition office simply turns into a bottleneck.”<sup>83</sup>

Infantry divisions habitually had attached tank battalions or may have had combat commands from armored divisions. During Operation COBRA, the 1<sup>st</sup> Infantry received the attachment of Combat Command B and its supporting slice elements from the 3<sup>rd</sup> Armored Division. There were two types of armored divisions: a heavy and light. The 3<sup>rd</sup> Armored Division was a heavy division which meant that it had two armor regiments of three tank battalions each and one armored infantry regiment of three armored infantry battalions.<sup>84</sup> In terms of logistics units, the main difference between an infantry division and an armored division was that instead of separate companies, the armored division had a full maintenance battalion, with three maintenance companies, and a full supply battalion to support it.<sup>85</sup> The supply battalion had two truck companies, each with 48 trucks and trailers, a medical detachment, and a headquarters company. Attached service and truck companies could augment the supply battalion.<sup>86</sup> There were some other logistical differences. Because of the heavier Class V requirements for an armored division, there were normally two additional attached truck companies to move that

---

<sup>83</sup>Lieutenant Colonel H.D. Kehm, “Artillery Ammunition Supply,” *The Field Artillery Journal* 32, no. 4 (1942): 271.

<sup>84</sup>Steven J. Zaloga, *US Armored Divisions: the European Theater of Operations, 1944-45* (Oxford: Osprey Publishing, 2004), 17.

<sup>85</sup>Field Manual 101-10: *Staff Officers' Field Manual: Organization, Technical, and Logistical Data* (Washington, D.C.: War Department, 1944), 140.

<sup>86</sup>Field Manual 17-57: *Supply Battalion, Armored Division* (Washington, D.C.: War Department, 1942), 1-6.

ammunition.<sup>87</sup> Finally, each tank battalion and each armored infantry battalion had their own respective service company.<sup>88</sup>

The role of the G4 was essential to division logistics, despite the apparent superfluity to the artillerymen. This section was responsible for planning, preparing, and supervising supply, evacuation of men and materiel, transportation, maintenance, and other administrative matters throughout the division. The G4 himself was part of the general staff but he had a number of individuals working for him who were part of the special staff.<sup>89</sup> These special staff officers often had dual roles where they served as an advisor (staff officer) and a commander.<sup>90</sup> For example, as previously stated, about 10 percent of the maintenance company was actually on the division staff as was about 10 percent of the division quartermaster company.<sup>91</sup> The special staff included the division ordnance officer who was responsible both for maintenance and ammunition as well as the division quartermaster who handled supply and transportation.<sup>92</sup> The regimental S4 was the division G4's counterpart in the infantry regiment. In keeping with the multiple-responsibilities-to-save-manpower trend, his deputy also served as the regimental service company commander.<sup>93</sup>

---

<sup>87</sup>*Field Service Regulations: Logistics*, 65.

<sup>88</sup>Zaloga, 28-35.

<sup>89</sup>This was the pre-integrated army with only men in these units and positions.

<sup>90</sup>Field Manual 101-5: *Staff Officers' Field Manual* (Washington, D.C.: War Department, 1940), 15-17.

<sup>91</sup>Sayen, 23.

<sup>92</sup>*Staff Officers' Field Manual*, 23-27. The Division Transportation Officer (DTO) and the Division Ammunition Officer (DAO) special staff positions were to develop later. It is interesting to note that the Division G4 was perhaps the first "multi-functional" logistician.

<sup>93</sup>Sayen, 48.

## **Doctrine & the results: what should have happened and what happened**

In World War II, during offensive operations, units would normally consume a much larger amount of fuel than usual but conversely a smaller amount of ammunition. Initially this was not an issue for the division, corps, or army. Despite a 3,000 percent increase in fuel consumption by vehicles in First Army from D-Day until the start of Operation COBRA, the fuel shortages which slowed the pace of the advance did not develop until August and September.<sup>94</sup> The division required approximately 900 gallons of gasoline to tactically move one mile.<sup>95</sup> At the start of Operation COBRA, the 1<sup>st</sup> Infantry Division had a 10.5 day stockpile of fuel; however, by the end of the August because of the rapid pursuit across France as well as the finite numbers of trucks to distribute fuel, the division was down to less than half a day of fuel on-hand.<sup>96</sup> Captain John J. King, the commander of the 1<sup>st</sup> Quartermaster Company throughout the war, did not just have the problem of supplying fuel to the division, but he was also extremely busy with all the tasks of supporting the division. From his after action review dated August 4, 1944, his company strength was 50 percent greater than his authorized strength as well as augmented by a quartermaster detachment.<sup>97</sup>

---

<sup>94</sup>Steve R. Waddell, *US Army Logistics: the Normandy Campaign* (Westport: Greenwood Press, 1994), 65.

<sup>95</sup>*After Action Report, G4 Section (JUN 44-DEC 44 & DEC 45)*, 20.

<sup>96</sup>James S. Corum, "Supplying the Big Red One," *Forbes* (June 5, 2008), under "France--July 1944," <http://www.forbes.com/2008/06/05/logistics-wwii-usarmy-tech-logistics08-cx-jc-0605normday.html> (accessed August 10, 2009).

<sup>97</sup>Captain John J. King, *1<sup>st</sup> Quartermaster Company: Report After Action* (Coutances: 1<sup>st</sup> Quartermaster Company, 1944), 1. Ross and Romanus also comment on page 472 that he may have been able to retain the older 1942 TO&E for an infantry division which authorized a quartermaster battalion (QM BN) not company. I think however that the additional strength was also from Detachment A of the 3275<sup>th</sup> QM BN which was augmenting the company according to the AAR.

Besides fuel, the division consumed a large quantity of ammunition. The 1<sup>st</sup> Infantry Division was not the only division rapidly firing ammunition; however, because of the rigidity (i.e. limitations on the number of rounds that could be fired) of the Class V plan at the theater level--it posed some risks. "Ordnance officers could do very little once the invasion began other than rely on emergency requisitions and ration the available supply of ammunition."<sup>98</sup> The administrative order for Operation COBRA for the 1<sup>st</sup> Infantry Division shows very specific controlled supply rates for mortar and artillery weapons systems.<sup>99</sup> For instance, each regiment was limited to only 1,650 rounds per day of 60mm mortar and senior leaders told commanders to "exercise necessary control to insure above restrictions not being exceeded."<sup>100</sup> Logisticians advised commanders that their units would not be allowed extra ammunition beyond their basic load.<sup>101</sup> Shipping problems to the continent and delivery over the beaches to the theater were the ultimate causes for the problem of lack of ammunition. Throughout July some stockage levels were dangerously low and the First Army imposed rationing.<sup>102</sup> The army lifted these rates for COBRA with the exception of the rates previously identified. Additionally, the division maintained 200 tons of ammunition on one of the attached truck companies as a forward emergency ASP.<sup>103</sup> There were a finite number of service troops within the

---

<sup>98</sup>Waddell, 44-45.

<sup>99</sup>*Sustainment in the Theater of War*, 6-16. CSR is how much ammunition a higher headquarters will allow a subordinate unit to have while the RSR (Required Supply Rate) is how much a unit's logistician calculates that it needs.

<sup>100</sup>Lieutenant Colonel Clarence Eymer, *1<sup>st</sup> Infantry Division: Administrative Order* (France: 1<sup>st</sup> Infantry Division G4, 1944), 2.

<sup>101</sup>Eymer, 1.

<sup>102</sup>Roland G. Ruppenthal, *Logistical Support of the Armies, Volume I* (Washington, D.C.: U.S. Government Printing Press, 2000), 445-449.

<sup>103</sup>*After Action Report, G4 Section (JUN 44-DEC 44 & DEC 45)*, 25. Ammunition Supply Point.

division so the 701<sup>st</sup> Ordnance (Light Maintenance) Company attached eighteen soldiers to that truck company (the 3891<sup>st</sup> Quartermaster Truck Company) to assist in managing the division's ammunition train.<sup>104</sup>

According to their after action review, the 701<sup>st</sup> Ordnance Company was extremely busy both before and during Operation COBRA. Captain Raymond C. Huntoon reported that the soldiers were working around the clock to repair the division's equipment. In the days before the assault, the 252<sup>nd</sup> Ordnance Battalion assisted them in doing a complete technical inspection of the entire division's vehicles and conducting automotive repairs. One of his main lessons learned was that the divisional ordnance company should carry an additional basic load of ammunition for the division.<sup>105</sup> It appeared that ammunition was a high priority on everyone's minds.

The 1<sup>st</sup> Medical Battalion under Lieutenant Colonel Samuel Bleichfield provided medical support to the division's organic units.<sup>106</sup> According to their after action review, the medical battalion functioned fairly closely to doctrine with subordinate companies moving with their respective combat teams and establishing clearing stations while the attached 1<sup>st</sup> Platoon of the 47<sup>th</sup> Field Hospital served as a mobile reserve throughout the operation. Casualties sustained were moderately heavy compared to the beginning of the

---

<sup>104</sup>Captain Raymond G. Huntoon, *701<sup>st</sup> Ordnance Light Maintenance Company: After Action Report* (France: 1<sup>st</sup> Infantry Division, 1944), 2.

<sup>105</sup>Huntoon, 2.

<sup>106</sup>Knickerbocker, 413.

month. There were 578 soldiers wounded or sick for the six days from July 26 to July 31 inclusive.<sup>107</sup>

Combat Command B of 3<sup>rd</sup> Armored Division had its own organic logistical support. According to First Army records, an armored division consumed, on average, 15,000 gallons of gasoline a day along with eighty tons of ammunition.<sup>108</sup> Since Combat Command B was roughly one-third the size of an armored division, its requirements would approximate to 5,000 gallons a day of gasoline (plus additional POL types) and twenty-six tons of ammunition. Those supplies for Combat Command B became critical on July 27 when 1<sup>st</sup> Battalion, 16<sup>th</sup> Regiment actually had to halt its attack in order to allow a convoy of Class III and Class V to get through to Combat Command B.<sup>109</sup> The 3<sup>rd</sup> Armored Division slices would have been attached to Combat Command B to include elements of the 3<sup>rd</sup> Ordnance Maintenance Battalion, 45<sup>th</sup> Armored Medical Battalion, and the 3<sup>rd</sup> Supply Battalion.<sup>110</sup>

There were other logistical concerns too. In his after action report, Lieutenant Colonel Clarence M. Eymer (the division G4 during Operation COBRA) noted that the major supply shortages were knives, grenade launchers, and binoculars.<sup>111</sup> While these

---

<sup>107</sup>Major Leo B. Burgin, *Historical Records and History of Organization, 1<sup>st</sup> Medical Battalion* (Marigny: Headquarters, First Medical Battalion, 1944). Lieutenant Colonel Bleichfield as well as nineteen other soldiers from his battalion received the Silver Star for this operation. Mortuary affairs personnel tracked the total number killed.

<sup>108</sup>Zaloga, 44. To reiterate, 3<sup>rd</sup> AD was one of two “heavy” armored divisions in inventory and commanders could therefore subdivide into three equal parts as opposed to a “light” armored division with two parts and a reserve.

<sup>109</sup>Carafano, 204.

<sup>110</sup>Zaloga, 78. I only found a reference to the 3<sup>rd</sup> Supply Battalion online at the 3<sup>rd</sup> Armored Division association, under “Order of Battle, World War II,” [http://www.3ad.org/wwii/wwii\\_order\\_of\\_battle.html](http://www.3ad.org/wwii/wwii_order_of_battle.html) (accessed November 24, 2009).

<sup>111</sup>Knickerbocker, 409.



shortages may have caused inconvenience to the units, they certainly were not limiting factors to the division's operations. Incredibly, the early phases of the operation had no major losses of equipment.<sup>112</sup> Divisions in combat typically consumed about 350 tons of supplies per day.<sup>113</sup> The 1<sup>st</sup> Infantry did not appear to have issues with food, water, or any other class of supply.

There were a number of contemporary lessons learned by the 1<sup>st</sup> Infantry Division during Operation COBRA. Even though the sustainment of forces functioned well throughout the operation, there were some inherent issues which were never truly resolved until the end of the war. At the conclusion of World War II, General Eisenhower convened a series of studies known as the General Boards, United States Forces, European Theater, to analyze all aspects of the European Theater of Operations. These boards were probably the most comprehensive after action reviews ever conducted after operations. Yet, since war is a fluid activity complete with friction and fog, they did not solve every problem nor could they anticipate future problems. General Boards or other entities after the war addressed and corrected some problems. Thankfully most of them have remained anachronistic to today. One interesting issue was a trend of officers holding both staff and command billets, such as being the quartermaster company commander and the division quartermaster officer.<sup>114</sup> Medical evacuation probably offered the least lessons learned. Despite what doctrine said but thanks to the adequate numbers of army ambulances, units were required to stock larger medical supplies than

---

<sup>112</sup>*After Action Report, G4 Section (JUN 44-DEC 44 & DEC 45)*, 25. This appears rather amazing but I am not sure if the G4's AAR included the attached elements (CCB, Tank Battalion, truck companies, etc).

<sup>113</sup>Van Creveld, 215.

<sup>114</sup>*Staff Officers' Field Manual*, 17.

planned. There were rarely any patients who were hand carried from the battalion aid stations to the collecting stations.<sup>115</sup> One of the more applicable General Boards was Study Number 28, “Supply Functions of the Corps.” Corps then, like divisions today, do not have their own combat service support assigned. This report posited four recommendations. First, corps troops should have limited operational stocks of supplies available for emergencies. Second, allow for similar-level maintenance operations in the corps. Third, decentralize service units (e.g. laundry and bath) to include corps areas. Finally, transportation and quartermaster headquarters elements should be an assigned or organic part of a corps headquarters in order to provide command and control to attached service units. These recommendations are still applicable today for a division headquarters in place of a corps headquarters.<sup>116</sup> By 1948 when the army published the next Table of Organization and Equipment for an infantry division, the army firmly rejected General McNair’s lean system and replaced it with a division of nearly 19,000 soldiers.<sup>117</sup>

Ultimately, logistics was a combat enabler and not a limiting factor to Operation COBRA. General Collins later noted, “I can recall no real supply difficulties that hampered the actual operation.”<sup>118</sup> In just a few short years at war, the United States

---

<sup>115</sup>Major Joseph B. McGee, “Combat Observations of an Infantry Division G4,” *Military Review* (1946), 35.

<sup>116</sup>The General Board, ETO, *Supply Functions of Corps, Study Number 28* (European Theater: United States Forces, 1945), 1-8. This may have been the foundation for the Corps Support Command concept.

<sup>117</sup>Sayen, 74. Actually there was one other TO&E published in 1945 but this was the last of the WWII era.

<sup>118</sup>“VII Corps in Operation COBRA (1),” *Lieutenant General J. Lawton Collins Papers, Box 5* (July 1944), 16.

Army had developed a huge logistics system to sustain operational maneuver. It provided the army with massive amounts of fuel, ammunition, maintenance, and medical support to enable it to conduct a truly modern, mechanized campaign. The lessons learned would be refined during the Cold War and would still be applicable half a century later.

## **CASE STUDY--OPERATION DESERT STORM**

On August 2, 1990 Saddam Hussein invaded Kuwait and quickly occupied the entire country. He posed a strategic danger to the world's oil supply and the balance of power in the Middle East. The United States responded by supporting a United Nations resolution to force the Iraqi Army from Kuwait. General H. Norman Schwarzkopf, the commander of U.S. Central Command had the responsibility for theater strategic and operational command and control of U.S. and coalition forces in their defense of Saudi Arabia (Operation DESERT SHIELD) and their actions to evict the Iraqis from Kuwait (Operation DESERT STORM).<sup>119</sup>

### **Strategic and operational levels of war**

Barely half a century after Operation COBRA, the Big Red One, now with the sons and grandsons of the men who had plowed through the Normandy hedgerows, would plow through another barrier and into the teeth of the fourth largest army in the world. During Operation DESERT STORM, the 1<sup>st</sup> Infantry Division would conduct a breaching operation and envelopment, again as part of the VII Corps, in order to destroy the Iraqi Army in Kuwait and Iraq. This was the *piece de resistance* of operational art in

---

<sup>119</sup>John S. Brown, "The Maturation of Operational Art: Operations Desert Shield and Desert Storm" in *Historical Perspectives on the Operational Art*, ed. Michael D. Krause and Cody R. Phillips (Washington, D.C.: Center of Military History, 2007), 444-451.

the 20<sup>th</sup> Century. According to John Brown, a former chief of the Center of Military History and a battalion commander in the 1<sup>st</sup> Infantry Division during the campaign, "the 1990 American heavy divisions had acquired a depth, breadth, and potency of geographical reach that elevated them into operational building blocks. Indeed, the 1990 division...assumed the mission of the 1945 corps."<sup>120</sup>

The 1990 U.S. Army division was a large, self-sustaining army organization, capable of independent maneuver, and organized with a specific set of combat, combat support, and combat service support units. It would fight as part of a corps which had its own combat, combat support, and combat service support units too. There were four different types of divisions: armored/mechanized infantry, airborne, air assault, and light infantry. The mechanized division consisted of two mechanized infantry brigades each with three infantry battalions and one armored brigade with three tank battalions. Other supporting arms included an aviation brigade, a combat engineer brigade, and a field artillery brigade. There were additional combat support and service support units including a division support command.<sup>121</sup> A typical armored division would consist of 384 Abrams tanks, 224 Bradley infantry fighting vehicles, and thousands of other tracked and wheeled vehicles.<sup>122</sup>

Major General Thomas Rhame's 1<sup>st</sup> Infantry Division was a mechanized division; however, when the army alerted it for deployment, 3<sup>rd</sup> Brigade / 2<sup>nd</sup> Armored Division became its third brigade thereby giving it the force of an armored division. All three

---

<sup>120</sup>Ibid., 443-444.

<sup>121</sup>See later in this chapter for a discussion of division support command role, missions, and function.

<sup>122</sup>Field Manual 71-100: *Division Operations* (Washington, D.C.: U.S. Government Press, 1996), 1-1 – 1-4.

maneuver brigades consisted of one mechanized infantry battalion and two tank battalions. The division aviation brigade controlled the division reconnaissance squadron known as the 1<sup>st</sup> Squadron, 4<sup>th</sup> Cavalry and two aviation battalions.<sup>123</sup> The division artillery consisted of three self-propelled 155mm artillery battalions as well as one multiple launch rocket system (MLRS) battery. The only difference among the other supporting arms was that there was only an engineer battalion instead of an engineer brigade.<sup>124</sup>

### **Combat operations**

Lieutenant General Frederick M. Franks, Jr. commanded the VII Corps. He envisioned a six-phased operation that focused on the defeat of the Iraqi *Republican Guard*. The first two phases involved the deployment and positioning of the corps. The actual attack would begin in phase three with the breaching of the Iraqi defensive positions. Phase four was the defeat of the Iraqi *VII Corps*. The key element was phase five: the defeat of the Iraqi *Republican Guard* that General Schwarzkopf had identified as the Iraqi center of gravity and the key to victory.<sup>125</sup> The operation's final phase was the defense of Kuwait. After a half century, the 1<sup>st</sup> Infantry Division was once again poised to conduct mounted maneuver warfare by attacking into the teeth of a fortified enemy line.<sup>126</sup>

---

<sup>123</sup>Stephen A. Bourque and John W. Burdan III, *The Road to Safwan: the 1st Squadron, 4th Cavalry in the 1991 Persian Gulf War* (Denton: University of North Texas Press, 2007), 23. The army did augment the squadron with nine M1 Abrams tanks.

<sup>124</sup>Bourque, 467. See Appendix G for the division task organization.

<sup>125</sup>FM 3-0: *Operations*, 6-8. "A *center of gravity* is the source of power that provides moral or physical strength, freedom of action, or will to act."

<sup>126</sup>Bourque, 35. See Appendix H for map of DESERT STORM.

Ground Attack Day or G-Day, February 24, 1991, became the second time in American history when the United States Army had won its first battle of a war. Because of strategic guidance, the division began its attack a day early.<sup>127</sup> An intense thirty minute artillery barrage followed more than a month of punishing air attack. At 1500 hours, the Big Red One moved toward the Iraqi defensive line with the 2<sup>nd</sup> Brigade on the right and the 1<sup>st</sup> Brigade on the left. Across the six kilometer front stormed four combined arms battalion task forces with the reconnaissance squadron and two tank battalions trailing close behind--the exploitation forces. An hour later they had opened sixteen lanes in the breach. The division's combat forces were mostly through the breach but there were significant field artillery and logistics units still needing to pass. General Franks halted the attack for the night in order to prevent fratricide (a serious risk during the campaign). The final passage through the breach would come the next day.<sup>128</sup>

As the sun rose on day two of the ground war, February 25, the Big Red One was still located in the breach with two brigades forward and the third brigade to the rear poised to continue the attack.<sup>129</sup> The weather was poor and the potential for fratricide was high. The attack recommenced with an artillery barrage and all three brigades abreast. They destroyed the Iraqi 26<sup>th</sup> *Infantry Division* and captured an enemy brigade commander and general in the process. Earlier in the day, the 1<sup>st</sup> Infantry started to guide

---

<sup>127</sup>Ibid., 264. Actually 15 hours in advance.

<sup>128</sup>Richard M. Swain, "*Lucky War*": *Third Army in Desert Storm* (Ft. Leavenworth: US Army Command and General Staff College, 1994), 232-237.

<sup>129</sup>Bourque, 251.

the British 1<sup>st</sup> Armored Division through the passage of lines. The passage of lines went relatively smoothly, allowing the British to continue the attack into the Iraqi forces.<sup>130</sup>

In the early morning hours of February 26, day three of the ground war, the Big Red One was moving steadily towards an assembly area as a corps reserve behind the 2<sup>nd</sup> Cavalry Regiment. They had conducted the passage of lines for the British but friction was everywhere as fatigue sapped at the soldier's energy and raised the specter of fratricide. As the division was consolidating, VII Corps issued an operational branch plan for it to conduct a forward passage of lines through the 2<sup>nd</sup> Cavalry and finish the destruction of Iraqi forces in an area called Objective NORFOLK.<sup>131</sup> Fighting tenaciously through the night and day the 1<sup>st</sup> Infantry secured the rest of Objective NORFOLK and continued to battle the Iraqi remnants. By the end of the day on February 27, the attack by the Big Red One had defeated two Iraqi maneuver brigades--a brigade of the *Tawakalna Division* and the *37<sup>th</sup> Brigade / 12<sup>th</sup> Armored Division*.<sup>132</sup>

The Big Red One had traveled more than 130 kilometers in the previous twenty-four hours. All of the brigades had to conduct refuel operations, which delayed the resumption of the attack on the morning of February 28. Reminiscent of their drive across France in the summer of 1944, the division was now in exploitation mode across Kuwait. During the afternoon, the exploitation slowed as the 1<sup>st</sup> Infantry fought through challenging terrain and pockets of Iraqi resistance. As the sun was setting on day four of the ground war, the 1<sup>st</sup> Squadron, 4<sup>th</sup> Cavalry, had established blocking positions in an

---

<sup>130</sup>VII Corps, *Combat SITREPs #36-43* (Saudi Arabia: VII Corps, 1991), #39-4. The 1<sup>st</sup> ID reported destroying 20 tanks, 15 APCs, and 60 artillery pieces.

<sup>131</sup>*Combat SITREPs #36-43*, #40-3.

<sup>132</sup>*Ibid.*, #41-3; Swain, 264.

area termed Objective DENVER, an area around the Basra-Kuwait City highway. At 1846 hours, the VII Corps G3, because of fatigue and friction, ordered the 1<sup>st</sup> Infantry to stop moving. At 2245 hours, U.S. forces announced a suspension of hostilities; they would resume later the next morning.<sup>133</sup>

The last few hours of the ground war, February 28 and March 1, were a confusing time for the 1<sup>st</sup> Infantry Division as it struggled through a series of ‘stop-start’ periods. It consolidated southwest of the Basra highway by early morning. First, VII Corps ordered them to cease fire then later directed them to recommence operations. The division was again low on fuel and not logistically ready to continue the attack that morning. Leaders were tired, staff work was sloppy, and General Schwarzkopf was giving tasks to tactical units instead of providing theater strategic guidance. In this trinity of fog, friction, and fatigue, the division was unaware of the U.S. Central Command commander’s intent to seize the road junction at Safwan. Along with the airfield, this area was to be the location for armistice negotiations with the Iraqis. Unfortunately it was still under control of the Iraqis at the time of the cease fire. Through some adroit diplomacy backed up with displays of firepower, the leaders of the Big Red One were able to force the Iraqis out of Safwan without bloodshed. With the signing of the armistice on March 3, Operation DESERT STORM came to a victorious close for the 1<sup>st</sup> Infantry Division.<sup>134</sup>

---

<sup>133</sup>Bourque, 372-280.

<sup>134</sup>Ibid., 387-406.



## **Operational level doctrine: SUPCOM / COSCOM / CSG / DISCOM**

The army had a number of months to build up a mature logistics structure in Saudi Arabia in preparation for expelling Saddam Hussein's forces from Kuwait. Like its preparations for Operation COBRA, there were well-stocked logistics bases and a high echelon logistics command and control structure. To support such a huge and massive undertaking, the U.S. Army created an organization called a theater army area command. Its purpose was to coordinate logistical support at the theater strategic and operational level to all army units within the theater of operations. It had a three part mission: first to provide direct support logistics to units in the army rear area; second to reinforce the corps support commands with logistics capabilities; third, to conduct rear area security within its designated zone. The region behind the combat zone was the area still known as the communications zone. The area command normally consisted of units such as area support groups (similar to corps support groups), transportation groups, POL groups, ammunition groups, etc.<sup>135</sup>

The 22<sup>nd</sup> Support Command (SUPCOM), led by Lieutenant General Gus Pagonis was the area command during Operation DESERT STORM. It was composed of a number of organizations including the 593<sup>rd</sup>, 226<sup>th</sup>, 301<sup>st</sup> Corps Support Groups, the 7<sup>th</sup> and 32<sup>nd</sup> Transportation Groups, the 475<sup>th</sup> POL Group, the 111<sup>th</sup> Ammunition Group, as well as a number of other support and service support organizations.<sup>136</sup> The 22<sup>nd</sup> Support Command functioned very well at the theater strategic and operational levels by

---

<sup>135</sup>Field Manual 63-4: *Combat Service Support Operations - Theater Army Area Command* (Washington, D.C.: U.S. Government Printing Press, 1984), 2-1 – 2-3.

<sup>136</sup>James D. Blundell, *Special Report - Operations Desert Shield and Desert Storm: The Logistics Perspective* (Washington, D.C.: Association of the United States Army, 1991), 17.

providing enormous logistical bases for the ground forces and enabling the movement and maneuver of each of the corps with massive amounts of transportation assets.<sup>137</sup> The 22<sup>nd</sup> SUPCOM established the ‘ninety-mile rule’ whereby they would push supplies forward ninety miles from the main logistics bases behind each corps at which point they would stop and establish temporary logistics bases. These temporary bases were never adequately established nor tested because of the short duration of the offensive.<sup>138</sup>

The corps support command (COSCOM) provided logistical support to the corps. According to Field Manual 63-3: *Corps Support Command*, the COSCOM “enables the corps to support high levels of combat over the duration of major operations... facilitates the corps commander’s ability to generate combat power at the decisive time and place.”<sup>139</sup> The corps support command, a general officer level command, contained a number of types of organizations: a special troops battalion and headquarters company, corps support groups, functional control centers (movement control and materiel management), medical brigades, and transportation groups. It was responsible for conducting and coordinating all the logistics functions within the corps – fix, fuel, man, arm, move, and sustain. While it was normally assigned to a specific corps, its components were tasked organized based on the area of operations and the mission.<sup>140</sup>

Major General James S. McFarland commanded the 2<sup>nd</sup> Corps Support Command

---

<sup>137</sup>Ibid., 12. The army established LOG Base Echo to support VII Corps.

<sup>138</sup>22<sup>nd</sup> Support Command, *After Action Report, Executive Summary, Volume I* (Dhahran: 22<sup>nd</sup> SUPCOM, 1991), 11-12.

<sup>139</sup>Field Manual 63-3: *Corps Support Command* (Washington, D.C.: U.S. Government Printing Press, 1993), 1-1.

<sup>140</sup>Ibid., 1-1 – 1-25.

supporting the VII Corps.<sup>141</sup> It consisted of the 229<sup>th</sup> Movement Control Center, the 800<sup>th</sup> Materiel Management Center, and five support groups: 159<sup>th</sup>, 43<sup>rd</sup>, 16<sup>th</sup>, 7<sup>th</sup>, and 30<sup>th</sup>.<sup>142</sup>

There were two types of corps support groups (CSG): a forward one which provided direct support to non-division elements within a specific division and a rear one which provided area support to units in the corps rear area and reinforcing support to the forward groups.<sup>143</sup> Many divisions had an active duty support group collocated on the same installation with the division. However, this was not the case with the Fort Riley, Kansas based 1<sup>st</sup> Infantry Division whose support unit came from Fort Hood, Texas. The corps and corps support group staffs and the division and division support command staffs would have a very close, habitual relationship. “The peacetime habitual relationship between supported and supporting units eases the transition to war.”<sup>144</sup> While the support group headquarters usually had a habitual relationship with a division, its subordinate units, known as corps support battalions (CSB), were task organized based on the group mission. There were also two types of battalions: a forward one located in the division rear area and a rear one located behind the division rear boundary. The former had the mission to provide area support to corps units in the division rear boundary and reinforcing support to the main support battalions and forward support battalions. The rear battalion provided area support to corps units operating behind the division area. These battalions were task organized with functional logistics companies

---

<sup>141</sup>Bourque, 470.

<sup>142</sup>Thomas D. Dinackus, *Operation Desert Storm: Allied Ground Forces, Order of Battle* (Alexandria: PSI Research, 1995), 3-4.

<sup>143</sup>*Corps Support Command*, 1-17 – 1-20.

<sup>144</sup>Field Manual 54-30: *Corps Support Groups* (Washington, D.C.: U.S. Government Printing Press, 1993), 4-13.

based on mission requirements. These could be transportation, maintenance, field services, ammunition, or other functional units.<sup>145</sup> The support group smoothly bridged the gap between operational level logistics (the corps support and area commands) and tactical level logistics (the division support command).

Colonel James C. Martin commanded the 159<sup>th</sup> Corps Support Group which was in direct support of the 1<sup>st</sup> Infantry Division.<sup>146</sup> It was a forward group consisting of the 87<sup>th</sup> CSB and the 286<sup>th</sup> CSB with various transportation, maintenance, and supply and service companies attached. The 159<sup>th</sup> Group distributed over 108,000 meals per day; during the ground offensive they provided over 1,000,000 gallons of fuel and 2,000,000 gallons of water. Although logistics problems never really hampered combat operations, not everything went smoothly. There was never an adequate amount of transportation capability. Friction was definitely present in their area of operations. Since there often were frequent task organization changes by 2<sup>nd</sup> COSCOM, there was a significant amount of redundancy in reporting requirements. Finally, integration of reserve component units into command relationships with which they are not normally associated caused significant friction.<sup>147</sup> However, Major General Rhame had a slightly different view. In referring to the corps support group he said, “It doesn’t work worth a damn in the knowledge of how the division moves and how you tactically support a division. We

---

<sup>145</sup>*Corps Support Groups*, 4-1 – 4-6. During the author’s two years in command of the 494<sup>th</sup> Transportation Company, the company served in two different CSGs and under five different battalion commanders in three CSBs.

<sup>146</sup>Major Dennis T. Boehler, *159th Support Group: Desert Shield & Desert Storm Historical Report* 1991 (APO New York: 159<sup>th</sup> Support Group, 1991), Tab G, Appendix 3.

<sup>147</sup>*Ibid.*, 1-8. The CSG referred to this as the “good-old-boy” network amongst active duty units (ironic in that is often the view from AC units about some RC units). The 87<sup>th</sup> CSB deployed with the 1<sup>st</sup> ID from Germany and the author assumes the relationship between the DISCOM and the 87<sup>th</sup> CSB is what they are referring to.

have gone in saying those guys ought to be habitually associated with the division they're going to be moving with so we can look them eyeball to eyeball and we can do some of these things in training.”<sup>148</sup> Despite challenges with the support group, General Rhame did control his own division support command which was organic to the 1<sup>st</sup> Infantry Division.

The mission of the division support command (DISCOM) was to provide “division-level logistics and HSS (health service support) to all organic and attached elements of the division.”<sup>149</sup> During World War II, a division commander only had two separate companies to handle logistics at the division level. In 1991, there was a brigade size logistics command. The division support command had three organic elements which stayed with the organization: the headquarters company, the aviation maintenance company (an aviation support battalion in some cases), and the main support battalion (MSB). The support command also had three forward support battalions (FSB) which were normally attached or OPCON to the brigades. This was a key aspect of its mission because it provided the command with an ability to leverage assets.<sup>150</sup> “The DISCOM commander and staff are responsible for tailoring resources to support tactical operations. They maintain constant contact with the division staff to anticipate future support requirements--who will require what types and amounts of support in what battlefield locations at what times.”<sup>151</sup> The commander could accomplish this by weighting the main effort with the main support battalion. Besides the control of these assets, the support commander had a number of key relationships.

---

<sup>148</sup>Interview with MG Thomas Rhame (July 26, 1991), 74.

<sup>149</sup>Field Manual 63-2: *Division Support Command Armored, Infantry, & Mechanized Infantry Divisions* (Washington, D.C.: U.S. Government Printing Press, 1991), 1-1.

<sup>150</sup>Leveraging is the ability to balance capabilities against requirements.

<sup>151</sup>Field Manual 63-20: *Forward Support Battalion* (Washington, D.C.: U.S. Government Printing Press, 1990), 2-3.

Field Manual 63-2: *Division Support Command*, states “The DISCOM commander is the principle logistics operator of the division. Because he executes a large part of the division support plan, both he and his staff must work closely with the G4 and the G4 staff. This coordination provides the best support possible to the division.”<sup>152</sup> The support commander assisted in setting logistics policies and priorities within the division. “The division G4 seeks this advice and ensures its consideration in the process.”<sup>153</sup> These leaders had to work in unison and have a professional understanding of each other’s roles: “the relationship between the division G4 and the DISCOM commander must be extremely close because of the similarities of interest.”<sup>154</sup> Perhaps even more important than the personal relationship was the inherent unit relationship that the support command had with other brigades within the division. “It is essential that the DISCOM commander and staff develop a close relationship with supported units.”<sup>155</sup> Colonel Robert Shadley commanded the 1<sup>st</sup> Infantry Division Support Command during Operation DESERT STORM.<sup>156</sup> Lieutenant Colonel John Andrews was the G4 of the 1<sup>st</sup> Infantry Division.<sup>157</sup>

While the support command was the executor of logistics in the division, the G4 developed the concept of support. The G4 was responsible for developing the division’s plans, policies, and priorities. He coordinated with other staff members as well as the

---

<sup>152</sup>*Division Support Command Armored, Infantry, & Mechanized Infantry Divisions*, 2-1

<sup>153</sup>*Ibid.*, 2-1.

<sup>154</sup>*Ibid.*, 1-1.

<sup>155</sup>*Ibid.*, 2-1. None of these relationships exist now as there is no longer a division support command.

<sup>156</sup>Bourque, 467.

<sup>157</sup>Interview with LTC John Andrews (July 24, 1991), 1.

support commander on logistics issues.<sup>158</sup> His main mission was to direct and synchronize the division's combat service support functions: fix, fuel, arm, move, and sustain. The G1 handled manning. When requirements exceeded the support command's capabilities, then the G4 coordinated with the corps support command for additional logistics assets.<sup>159</sup> The G4 also worked closely with the commander of the main support battalion.

### **Tactical level doctrine: 35MM**

Lieutenant Colonel Lloyd Waterman commanded the 701<sup>st</sup> MSB during Operation DESERT STORM.<sup>160</sup> The main support battalion had a two part mission: "it supports units in the division rear and provides designated and reinforcing supporting to the FSBs".<sup>161</sup> This support battalion was the main medical and logistics provider in the division rear area. It was composed of seven companies: supply and service company, transportation motor transport company, light maintenance company, heavy maintenance company, missile support company, medical company, and a headquarters company. It provided transportation, supply, maintenance, and medical support to units operating in the division rear area as well as reinforcing support to the forward battalions.<sup>162</sup> The support battalion had numerous organizational relationships which were imperative to the smooth functioning of logistics within the division. The battalion received its priorities

---

<sup>158</sup>*Division Support Command Armored, Infantry, & Mechanized Infantry Divisions*, 1-1.

<sup>159</sup>*Division Operations*, 3-13.

<sup>160</sup>Bourque, 467.

<sup>161</sup>Field Manual 63-21: *Main Support Battalion* (Washington, D.C.: U.S. Government Printing Press, 1990), 1-4.

<sup>162</sup>*Main Support Battalion*, 1-4 – 1-5.

from the support command; it provided logistics support directly to units in the division rear; it coordinated with and provided reinforcing support to the forward battalions; and it commanded and controlled subordinate logistics companies.<sup>163</sup> These capabilities and relationships made it the center of gravity for logistics within the division.

The maneuver brigade was a powerful organization with a headquarters company and a set number of maneuver battalions. Usually there three although they could command and control between two and five. The brigade received attachment of various combat support and service support units, e.g. the forward support battalion. The maneuver battalions had an organic support platoon and a medical platoon. The field artillery battalions retained a service battery consisting of a supply element, an ammunition platoon, and a maintenance platoon. These logistics assets provided unit level support to their permanent headquarters. This included supply distribution, maintenance, health service support, food service, transportation, and graves registration--all at the unit level.<sup>164</sup>

Unlike regimental combat teams with their regimental service companies during World War II and prior to the modularity concept of today, each maneuver brigade would have a forward support battalion attached or OPCON. Normally this would be a habitual relationship. The 101<sup>st</sup> FSB (Lieutenant Colonel Edwin Buffington) was attached to 1<sup>st</sup> Brigade; the 201<sup>st</sup> FSB (Lieutenant Colonel William Hand) was attached to 2<sup>nd</sup> Brigade; and the 498<sup>th</sup> FSB (Lieutenant Colonel Stephen Marshman) was attached to 3<sup>rd</sup> Brigade.<sup>165</sup> These battalions were composed of four companies each: a headquarters and headquarters detachment, a supply company, a maintenance company, and a medical company. The battalion provided support not just to its

---

<sup>163</sup>Ibid., 2-2.

<sup>164</sup>*Forward Support Battalion*, 1-1 – 1-4.

<sup>165</sup>Bourque, 467.



brigade but also to any division unit operating in the brigade area. Finally it could receive attachments directly from the main support battalion or a corps support battalion.<sup>166</sup>

The supply company of the forward support battalion had the responsibility for distributing fuel for the brigade. A typical armored division in the attack consumed more than 2,000 tons of fuel per day.<sup>167</sup> The five gallon can was now ubiquitous on the battlefield; the old staple, the 55-gallon drum, was still there too; a new item, the 500 gallon container known as a blivet, had arrived. The delivery of bulk fuel was a push based system. The brigade S4 along with the support battalion support operations officer submitted a forecast to the division materiel management center. The center in turn submitted a forecast to the corps support command. They in turn would either deliver the fuel directly to the forward support battalion's supply company or sometimes the main support battalion would provide it. In turn, the supply company would either establish a fuel point to refuel units in its area or it could send forward to each maneuver battalion a small fuel convoy to run a tactical refuel point. Because of mobility requirements, the forward support battalion was not authorized collapsible fuel tanks. The highest requirements for fuel are always during offensive operations.<sup>168</sup> Operation DESERT STORM was the model.

In addition to fuel distribution, the supply company was also responsible for ammunition operations. Initially ammunition was a push system based on forecasted

---

<sup>166</sup>*Forward Support Battalion*, 2-1 – 2-3.

<sup>167</sup>James F. Dunnigan and Austin Bay, *From Shield to Storm: High Tech Weapons, Military Strategy, and Coalition Warfare in the Persian Gulf* (New York: William Morrow and Company, Inc., 1992), 235.

<sup>168</sup>*Forward Support Battalion*, 7-11 – 7-15. The fuel convoy was often two tank-pump units or two HEMTT fuelers (Heavy Expanded Mobility Tactical Trucks).

requirements. By doctrine, this was supposed to transfer to a pull system based on actual demand. One of the biggest challenges for a support battalion was that it was required to be 100 percent mobile with its unit equipment. This meant that the supply company was limited to the amount of ammunition and other supplies that they could carry at any given time. Throughput distribution assisted this process by delivering directly from a corps storage area to the forward support battalion.<sup>169</sup> Ammunition requirements went from a battalion S4 to the brigade S4 to the division materiel management center. Each forward support battalion operated one ammunition transfer point where ammo handlers transferred class V from the supply company to a logistics package convoy which delivered the requested ammunition to the battalion.<sup>170</sup>

There were four levels to the maintenance system: operator/unit, direct support (DS), general support (GS), and depot.<sup>171</sup> The maintenance company of the support battalion provided direct support maintenance to the brigade. The main principle of maintenance operations was to repair forward. Unit maintenance collection points would receive unserviceable equipment in their respective brigade or division areas. Standard yet adjustable timelines determined how long repairs should take. If the number of repairers, tools, and repair parts were inadequate to fix vehicles in a given timeline, mechanics would evacuate them back to the main support battalion or to a supporting corps maintenance unit. In addition to running its own repair shop, the maintenance company would create maintenance support teams which would go forward to provide

---

<sup>169</sup>Ibid., 7-2.

<sup>170</sup>*Forward Support Battalion*, 7-16. CSR: Controlled Supply Rate

<sup>171</sup>Field Manual 100-10: *Combat Service Support* (Washington, D.C.: U.S. Government Printing Press, 1995), C-2.

DS maintenance to each maneuver battalion. Proper maintenance was and is extremely critical to the success of a mechanized force – especially during offensive operations.<sup>172</sup>

There were five echelons to combat health support during the 1990s. Echelon I was buddy aid as well as support from the battalion aid station; it provided lifesaving tasks to prepare the patient for the next level. The medical companies of the support battalions provided echelon II care; this added a number of specialized capabilities such as dental and optometry. The combat support hospital provided echelon III care; this was the first level with hospital facilities and postoperative treatment. The field hospital provided echelon IV; it stabilized those patients that would not be returning to duty. Finally echelon V was definitive care to patients in United States or European based hospitals. Although not a separate echelon, forward surgical teams could augment divisional units and provide them with urgent initial surgery.<sup>173</sup> The medical company of the support battalion, known as the forward support medical company, provided echelon II support to units within the brigade area. The company was composed of three sections: a company headquarters, a treatment platoon, and an ambulance platoon. The area support section operated the brigade clearing station which had a forty bed capability while the treatment section reinforced other medical elements and provided clinic services. The ambulance platoons evacuated casualties from the battalion aid stations to the brigade clearing station or from other collection points and ambulance transfer points. The evacuation process was much like during World War II: higher level medical units would send ambulances down to lower level units to evacuate casualties. The major

---

<sup>172</sup>*Forward Support Battalion*, 8-1 – 8-15.

<sup>173</sup>*Combat Service Support*, D-4 – D-5.

difference now was that air medical assets were capable of evacuating many of these casualties much faster and deliver them to a higher echelon of medical care.<sup>174</sup>

### **Doctrine & results: what should have happened and what happened**

During offensive operations, the most critical supplies are classes III, V, and IX. The greatest challenge would be maintaining these supplies over extended supply lines.<sup>175</sup> The quantities were enormous. Logisticians planned on consumption factors of 5,000 short tons of ammunition per day for an armored division in the attack.<sup>176</sup> A reserve unit which managed a rolling ammunition transfer point with 20 trailers loaded with ammunition augmenting the 101<sup>st</sup> FSB did not have enough assets to support 1<sup>st</sup> Brigade. Lieutenant Colonel Buffington said, “I think probably the hardest task or mission was the class V. Just being able to keep up with the maneuver guys, they were moving so fast...it almost became a 24 hour turnaround for my supply people to resupply.”<sup>177</sup> Transportation assets always seemed to be a limiting factor. For instance the maneuver units had some challenges moving their unit basic loads. “They were used to moving other supplies and TO&E equipment on their HEMTTs so they had to find alternate means to transport their ‘ash and trash’.”<sup>178</sup> But even dumping everything else was not enough to haul two ammunition basic loads. A significant concern and one that could have truly reduced the division’s mobility was that “when the minimum acceptable

---

<sup>174</sup>*Forward Support Battalion*, 9-1 – 9-11.

<sup>175</sup>*Ibid.*, 2-6.

<sup>176</sup>Dunnigan and Bay, 289.

<sup>177</sup>Interview with LTC Edwin L. Buffington (December 13, 1991), 20.

<sup>178</sup>*Ibid.*, 36.

amounts of ammunition ...were loaded by units, the ammunition exceeded the hauling capacity of every unit.”<sup>179</sup>

An adequate fuel supply was one of the most critical concerns to fuel consumers like combat arms battalion commanders as that would limit or enable the ability to conduct rapid maneuver. Lieutenant Colonel David Marlin, commander of 1<sup>st</sup> Battalion, 37<sup>th</sup> Armor, 2<sup>nd</sup> Brigade, whose tanks were almost dry by the end of the first day of the ground war remarked, “I was stressed out over fuel. It would be the most humbling experience of the war.”<sup>180</sup> On the fuel distribution side, the after action review for the 286<sup>th</sup> CSB reported that all of their POL assets were committed on an extended basis to the division support command. They lost all visibility of these assets because of the rapid exploitation and recommended in the future those assets should be OPCON directly to the support battalions.<sup>181</sup> However, the division never ran out of fuel. The main support battalion had a rolling forward element for emergency resupply with fuel, water, and rations. Ultimately the intervention of the senior logistician within the division was required. “There was a superhuman effort by our ADCS and the DISCOM Commander to find four tankers and to start a rotation with ...our own DISCOM assets to keep pushing fuel forward.”<sup>182</sup> When it mattered, there was a logistics colonel there with the same

---

<sup>179</sup>1<sup>st</sup> Infantry Division Staff, *Lessons Learned during Operation Desert Storm* (APO NY: 1<sup>st</sup> Infantry Division, 1991), 12.

<sup>180</sup>Lieutenant Colonel David W. Marlin, *History of the 4th Battalion, 37th Armor Regiment in Operation Desert Shield/Desert Storm* (Saudi Arabia: 4-37 AR, 1992), 421-423. The support platoon leader became lost after putting the wrong map sheet number in his GPS and going 80 km away with all thirteen fuel HEMTTs. Apparently the A Company never launched an attack that night because of the lack of fuel.

<sup>181</sup>Boehler, C-4. Annex C under the 286<sup>th</sup> Supply and Service Battalion.

<sup>182</sup>Andrews, 70-72. ADCS: Assistant Division Commander for Support

patch as the division commander who enabled the operational maneuver of the 1<sup>st</sup> Infantry Division.

Prior to the start of the ground campaign, in the massive move across the desert to reposition the two corps there was intense maintenance work conducted. On February 21, the VII Corps G4, Lieutenant Colonel Hays reported that after the 100 mile move into attack positions, the corps had sixty-two M1 Abrams tanks and fifty-seven M2/M3 Bradley infantry fighting vehicles which were dead-lined awaiting spare parts. That was equivalent to more than a battalion each of armor and infantry. This was mostly due to a significant shortage of repair parts.<sup>183</sup> It was not until February 25 that he reported the maintenance status as *amber*.<sup>184</sup> Operation DESERT STORM was the last major operation in the pre-internet era which hampered visibility on repair parts. The maintenance problems associated with the lack of spare parts could possibly have limited the pursuit of the Iraqi Army had the ground war lasted longer than 100 hours. The American Army was not ready for that. As Lieutenant Colonel Andrews, the division G4 attested to, “The supplies were in-country that we needed...but the visibility was not there.”<sup>185</sup> Twenty years later, web based applications and the possibilities offered by total asset visibility have greatly alleviated the plethora of twenty foot containers with unknown contents generating the ‘iron mountains’ of Operation DESERT STORM.

Combat health support during Operation DESERT STORM was outstanding. The tens of thousands of casualties of which some pundits were warning about thankfully

---

<sup>183</sup>Combat SITREP #36-43, #36-7. Class IX zero balance authorized stockage list (ASL) for ground units was averaging forty-four percent.

<sup>184</sup>*Ibid.*, #39-6. At this point 15 tanks and 38 IFV’s were dead-lined. *Amber* was a code for a very poor maintenance rate, not as bad as *black* though.

<sup>185</sup>Andrews, 53-54.

never materialized. A soldier wounded in the sands of Iraq had access to the most advanced medical care available. The 1<sup>st</sup> Infantry Division, however, did suffer the most casualties of the VII Corps: 21 killed in action and 67 wounded in action.<sup>186</sup>

There were 26 logistics lessons learned that the 1<sup>st</sup> Infantry Division recorded in its after action review. Some were contemporary for the American Army of the 1990s: logisticians needed GPS, the M16A2, and odometers that read in kilometers. Many lessons learned are applicable to today. Every fuel and cargo vehicle should be a HEMTT--in order to keep up with the advance over rough terrain.<sup>187</sup> Local purchase contracting officers are critical.<sup>188</sup>

The bottom line was that nothing failed due to logistics. There was a seamless linkage between the operational and tactical levels of logistics, with some minor exceptions. Although a risk of culmination existed, it was never paramount. Nor did it materialize due to the cessation of ground hostilities in 100 hours. The American Army designed the logistics architecture to support operational maneuver against Soviet forces during the Cold War. The test came in 1991. The results showed that the U.S. Army's logistics system of the early 1990s was thoroughly capable of sustaining operational maneuver during DESERT STORM.

---

<sup>186</sup>Bourque, 471.

<sup>187</sup>The echelon above brigade trucks are still designed for hardball highway driving.

<sup>188</sup>*Lessons Learned during Operation Desert Storm*, 12-17.

## **CASE STUDY – OPERATION GREEN DAWN<sup>189</sup>**

On a dusty road in Iraq, the G4 for the 1<sup>st</sup> Infantry Division looks over his Battle Command Sustainment Support System and agonizes over the operational readiness rate of the M1 Abrams tanks in 1<sup>st</sup> Brigade. Most of the parts required are back in the United States, the ‘iron mountains’ of supplies in theater are gone. Then suddenly his screen blanks out – his computer a victim of cyber warfare. The location is Iraq; the date is March 17, 2012. Following a civil war, the Iraqi military had collapsed and the country had fallen into near-anarchy.

### **Strategic and operational levels of war**

Iran, seeing an opportunity for regional hegemony invades and occupies the eastern third of Iraq, settling in with prepared defenses. The government of Iraq desperately requests American aid. Help arrives in the form of the 1<sup>st</sup> Infantry Division with four maneuver brigades and an aviation brigade. Completing reception, staging, onward movement, and integration is the 82<sup>nd</sup> Airborne Division headquarters and four maneuver brigades in Kuwait along with the 82<sup>nd</sup> Sustainment Brigade. The VII Corps, formally the V Corps in Europe, has flown into Baghdad to serve as the land component command. The 1<sup>st</sup> Theater Sustainment Command is providing all strategic and operational logistics for the theater; the 22<sup>nd</sup> Expeditionary Sustainment Command has just flown into Baghdad from Germany to serve as the forward logistics command in Iraq. The 7<sup>th</sup> Sustainment Brigade is in Kuwait functioning at the operational level of

---

<sup>189</sup>This notional scenario is from the author’s experiences in Iraq, his study of these units, and a review of Iran’s military capabilities. The author picked the title GREEN DAWN in honor of the failed Green Revolution in Iran in 2009 and the coming remake of the classic war movie *Red Dawn* in 2010.



logistics providing theater opening and theater distribution while the 1<sup>st</sup> Sustainment Brigade is rolling north with the 1<sup>st</sup> Infantry Division.

The U.S. Army became a brigade based army in the early twenty-first century. The brigade combat team has replaced the division headquarters as the lowest level headquarters which has all the war fighting functions as part of its organic make up. The brigade combat team of 2012 is more powerful than the maneuver brigade of DESERT STORM. They are now the army's basic tactical maneuver units.<sup>190</sup> Division's now serve at both the operational and tactical levels of war as headquarters which receive attachments of between two and five brigade combat teams as well as other support brigades. In Operation GREEN DAWN, the 1<sup>st</sup> Infantry Division has three attached heavy brigade combat teams and one light infantry brigade combat team. The heavy brigades each have two combined arms battalions (two tank companies, two rifle companies, one engineer company, and a headquarters company); a reconnaissance squadron with a headquarters troop and three ground reconnaissance troops; a fires battalion equipped with 155mm self-propelled artillery; a brigade special troops battalion with organic military intelligence, signal, and engineer capabilities; and a brigade support battalion (the descendent of a merger between the forward support and main support battalion). All brigade combat teams have between 3,400 and 4,000 soldiers.<sup>191</sup>

---

<sup>190</sup>Field Manual 3-90.6: *The Brigade Combat Team* (Washington, D.C.: U.S. Government Printing Press, 2006), 2-1. See Appendix I for the task organization of a heavy brigade combat team.

<sup>191</sup>*Ibid.*, A-1 – A-9.

## Combat operations

In 2012, Iran's conventional forces are significant they are the largest of all the Gulf States. Iran's Army is composed of thirteen divisions: four armored, six infantry, two commandos, and one airborne. Iran's four corps consist of these divisions along with artillery groups, aviation groups, and other smaller combat and support formations. They possess more than 1,600 main battle tanks and 640 armored personnel carriers.<sup>192</sup> The ground forces also consist of the 125,000 man *Islamic Revolutionary Guards Corps*. This is composed of units for irregular warfare, units which operate surface-to-surface missiles, and units which control chemical, biological, radiological, and nuclear weapons.<sup>193</sup> In early February, 2012, Iranian forces moved 100 km into eastern Iraq, stopped, and established a defensive line. Covering this is an intense air defense umbrella. The president has directed United States military forces to eject Iranian ground forces from Iraq.

The Iranian forces established a two-layered defensive belt to protect their positions. The Iranian *I Corps* was composed of the *1<sup>st</sup>, 2<sup>nd</sup>, 3<sup>rd</sup>, and 4<sup>th</sup> Infantry Divisions* holding their defensive lines while their *III Corps* was a mobile reserve with *1<sup>st</sup>, 2<sup>nd</sup>, and 3<sup>rd</sup> Armored Divisions*. On the morning of the first day of Operation GREEN DAWN, March 15, the *1<sup>st</sup> Infantry Division*, nearly a quarter of a century after DESERT STORM, attacked west from Baghdad to breach the Iranian defensive position. With their supporting fires battalions as well as close air support, *1<sup>st</sup> Brigade* was able to breach the

---

<sup>192</sup>Anthony H. Cordesman and Martin Kleiber, *Iran's Military Forces and Warfighting Capabilities* (Westport: Praeger Security International, 2007), 40-62. This data is as of 2007.

<sup>193</sup>Cordesman and Kleiber, 73-75.

positions and conduct a forward passage of lines for 2<sup>nd</sup> and 3<sup>rd</sup> Brigades to exploit. 4<sup>th</sup> Brigade (light infantry), followed and assumed their mission of holding open the breach. In a day's work, the 1<sup>st</sup> Infantry Division had destroyed the Iranian 2<sup>nd</sup> and 3<sup>rd</sup> *Infantry Divisions*.

The largest maneuver battle since Operation DESERT STORM occurred on day two of the offensive, March 16. The 1<sup>st</sup> Infantry Division with 2<sup>nd</sup> and 3<sup>rd</sup> Brigades abreast and 1<sup>st</sup> Brigade trailing in reserve attacked the right flank of the Iranian *III Corps*. After heavy attrition by AH-64 Apache helicopters, close air support, and artillery fire, the ground forces destroyed the remnants of the *1st Armored Division*. Next to fall would be the *2<sup>nd</sup> Armored Division*. In the process of defeating the *2<sup>nd</sup> Armored Division*, 3<sup>rd</sup> Brigade overran the Iranian *III Corps* command post at 1330 hours and captured the corps commander, who was under the impression he was fighting an entire U.S. armored corps, not just the 1<sup>st</sup> Infantry Division. Vaguely aware of a massive armored juggernaut throttling towards their right flank, the Iranian *3<sup>rd</sup> Armored Division* left their defensive positions and attempted to retreat. At 1700, the 1<sup>st</sup> Infantry Division with all three HBCTs abreast, found *3<sup>rd</sup> Armored Division* out of their defensive positions, retreating. They would never make the Iranian border. 1<sup>st</sup> Infantry Division destroyed them as the sun set on a battlefield, for the first time in a quarter of a century, littered with the burning hulks of thousands of enemy tanks, trucks, and armored personnel carriers. By 2330 hours, 2<sup>nd</sup> and 3<sup>rd</sup> Brigades had fired nearly all three basic loads of ammunition and were nearly out of fuel. Some of the support vehicles, however, were hybrid electric/gas vehicles equipped with experimental solar panels and improved batteries. Those vehicles still had plenty of fuel available. Just before midnight, a series of resupply convoys from the 1<sup>st</sup>

Sustainment Brigade distributed class III and class V directly to the forward support companies in the combined arms battalions and the fires battalions.

Day three of GREEN DAWN started with the Iranian *I Corps* and *III Corps* dislocated from their positions and in retreat. The 1<sup>st</sup> Infantry Division's three heavy brigades were racing towards the border in a high speed pursuit. However, the division commander without a main support battalion or a division support command was not able to weight his main effort with extra fuel and ammunition. Meanwhile, 4<sup>th</sup> Brigade, the light infantry brigade, their lack of mobility hindering them, were slowly moving forward. The tipping point came at noon when CNN and Al Jazeera announced that an uprising had overthrown the Iranian government and the new government was asking for an armistice.<sup>194</sup> The Iranian Army collapsed and by dusk the 1<sup>st</sup> Infantry Division had reached the border.

### **Operational level doctrine: TSC / ESC / Sustainment Brigade**

After the destruction of the World Trade Center on September 11, 2001, the Army Chief of Staff established six transformation imperatives to better improve logistics capabilities. First, the army would fight as a brigade-based army with self-contained units. The division would no longer have regularly assigned units but serve as a command and control headquarters. Second, the army logistics system would have to be responsive to a joint and expeditionary army. Third, the army needed to eliminate redundancy and streamline support. Fourth, logistics would have to use new technologies to link support from the continental United States to the theater of war. Fifth, the army

---

<sup>194</sup>With the bulk of the Iranian military, including the *IRGC* in Iraq or eastern Iran, it would be feasible for an uprising to take power in Tehran.

would have to be able to fight without reserve component forces for the first thirty days. Lastly, the future army would have to be as capable as the current army.<sup>195</sup> For the logistics community, this entailed a significant transformation at the operational and tactical levels of logistics.

The theater sustainment command is the operational level logistics provider for a theater of war. There is one for each theater army, now known as an army service component command, to cover every geographic combatant command.<sup>196</sup> The command assumed many of the roles and missions of the corps support command and division support command.<sup>197</sup> There are currently five commands in the army.<sup>198</sup> The mission of the theater sustainment command is “to plan, prepare, rapidly deploy, and execute command and control of operational level logistics support within an assigned theater.”<sup>199</sup> It can synchronize support from continental United States based organizations such as Army Materiel Command and U.S. Transportation Command. Normally commanded by a major general, it can command and control expeditionary sustainment commands or sustainment brigades.<sup>200</sup>

---

<sup>195</sup>*Modular Force Logistics Concept, Version 6* (Ft. Lee: Combined Arms Services Support Command, 2006), 7-8.

<sup>196</sup>Field Manual 4-93.4: *Theater Support Command* (Washington, D.C.: U.S. Government Printing Press, 2003), 1-2 – 1-3.

<sup>197</sup>*Sustainment in the Theater of War*, 2-6.

<sup>198</sup>*Logistics Force Structure Book* (Ft. Lee: Combined Arms Services Support Command, 2010), 34.

<sup>199</sup>*Modular Force Logistics Concept, Version 6*, B-2.

<sup>200</sup> *Ibid.*, B-2.

In 2012, there are fourteen expeditionary sustainment commands in the army.<sup>201</sup> The army should deploy the expeditionary sustainment command as a forward element of a theater sustainment command or as a logistics command and control headquarters within a smaller joint operating area. It deploys and conducts logistics operations to support all army forces either within a theater or a smaller area. The staff is a mirror of the theater sustainment command, except smaller. Normally commanded by a brigadier general, it provides command and control to one or more sustainment brigades.<sup>202</sup>

The sustainment brigade, commanded by a logistics colonel is the subordinate command of an expeditionary or theater sustainment command and provides the link between operational and tactical level logistics in a theater. It is a flexible organization – only the special troops battalion is organic. The missions of the sustainment brigade are to plan and execute theater opening (reception, staging, and onward movement), theater distribution, and sustainment within a certain area or theater. The brigade provides command and control to combat sustainment support battalions or functional battalions (e.g. fuel or transportation).<sup>203</sup> Following transformation, the army merged some capabilities and responsibilities of the area support groups, corps support groups, corps support commands, and division support commands into the sustainment brigade while the army deactivated the former units.<sup>204</sup> There is no longer an assigned division support command; sustainment brigades now provide general support to a division not direct

---

<sup>201</sup>Ibid., 35-37.

<sup>202</sup>*Modular Force Logistics Concept, Version 6*, B-6 – B-10.

<sup>203</sup>*The Sustainment Brigade*, 2-1.

<sup>204</sup>*Modular Force Logistics Concept, Version 6*, 11.

support.<sup>205</sup> In 2012 there are thirty-two sustainment brigades – thirteen in the active component and nineteen in the reserve component.<sup>206</sup> The combat sustainment support battalions, the building blocks of the sustainment brigade, are themselves modular. Their mission is to plan, coordinate, and conduct logistics operations. They normally support units on an area basis--i.e. they will support whichever unit is in a certain geographic area. Normally composed of between two and five functional logistics companies, they can be task organized to provide theater opening, distribution, sustainment, and life support.<sup>207</sup> They are very similar to the corps support battalions of DESERT STORM. The sister unit to this support battalion is the brigade support battalion which provides direct support to its brigade combat team.

### **Tactical level doctrine: 35MM**

The brigade support battalion is the organic sustainment unit in the brigade combat team. It is the single logistics provider to the brigade. Unlike its predecessor, the forward support battalion, the brigade support battalion is an organic element of the brigade combat team. It became more robust than the legacy support battalion with assets provided from the deactivating main support battalion. It is composed of a headquarters company, three functional companies (distribution, maintenance, and medical), and four forward support companies with one for each maneuver and fires battalion within the brigade.<sup>208</sup>

---

<sup>205</sup>*The Sustainment Brigade*, 1-5.

<sup>206</sup>*Logistics Force Structure Book*, 38-40.

<sup>207</sup>*Modular Force Logistics Concept, Version 6*, 17.

<sup>208</sup>*Sustainment in the Theater of War*, 6-1 – 6-6.

Assigned to the support battalion, forward support companies are usually attachments to the battalion they are supporting or in some cases OPCON. The forward support company consolidated the functions once performed by a maneuver battalion's support platoon during Operation DESERT STORM or by elements of the regimental service company during Operation COBRA. Composed of a distribution platoon and a maintenance platoon, commanded by a logistician, they provide supported battalions with classes I, III, V, and IX as well as maintenance and recovery. They do not provide medical support.<sup>209</sup>

Just like during Operations COBRA and DESERT STORM, class III is one of the critical concerns for maneuver commanders in the offense. All brigade combat teams are self-sustainable for up to seventy-two hours. Normally this equates to three days of supply with one on the vehicle system, one with the forward support company, and one with distribution company. The distribution company has three functional platoons: a transportation platoon, a fuel and water platoon, and a supply support platoon. The forward support company uses HEMTT fuel trucks to refuel the maneuver and fires battalions. To replenish those stocks, logisticians deliver bulk fuel either by throughput from the sustainment brigade to the forward support company or to the distribution company.<sup>210</sup> The distribution company also supplies class V.

Once again on the attack, the second greatest concern for all commanders is an adequate supply of ammunition. The army designed the brigade combat team to carry three combat loads of munitions to last for seventy-two hours. For an M1 Abrams tank

---

<sup>209</sup>Ibid., 6-2 – 6-6. After transformation, the maneuver battalion retained the medical platoon and its assets.

<sup>210</sup>*Sustainmetn in the Theater of War*, 6-2 – 6-14.



the combat load is forty rounds. Normally, the vehicle carries one load, the forward support company carries the second load, and the distribution company carries the third load. This means that an armor company with fourteen tanks has access to enough ammunition to theoretically engage 1,760 targets. Class V arrives at the ammunition transfer and holding point in the brigade support area in the form of an expeditionary support package, a series of rounds secured to pallets further secured to flat racks or placed in containers, or via throughput directly from operational level logistics system ammunition stocks. Conceptually, this is not much different than DESERT STORM. However, there were two significant changes: an increase in visibility of the operational and strategic level stocks through web-based automation and an increase in carrying capacity of tactical stocks.<sup>211</sup>

While the distribution company in the brigade support battalion is busy storing or distributing ammunition and fuel, the forward support companies and the field maintenance company are responsible for the brigade's maintenance in order to have all vehicles ready for offensive operations. Normally the field maintenance company is fully tasked conducting maintenance for the brigade combat team's units which are not part of the maneuver or fires battalions and can only provide limited backup support to the forward support companies. During transformation, the army compressed its maintenance system into two levels: field and sustainment maintenance. Organizational level and direct support levels merged to form field maintenance while general support and depot merged to form sustainment maintenance. The former focuses on repairing equipment

---

<sup>211</sup>*Sustainment in the Theater of War*, 6-15 – 6-17. Flat racks are used on the PLS – 1 per truck and 1 per trailer.

and getting it right back to the soldier by mostly replacing defective parts to make the vehicle or system function again. Sustainment maintenance--not conducted by the brigade support battalion--involves a more intense repair process with the goal of returning the item to the supply system. The omnipresent contractors of 2012 had just made their appearance on the battlefield during DESERT STORM. A brigade logistics support team handles contracting support for each brigade combat team by coordinating and synchronizing operational and strategic maintenance resources at the tactical level. For example, maintenance contractors from Army Materiel Command might be working down in the brigade support area.<sup>212</sup> The class IX repair parts system is conceptually similar to DESERT STORM.<sup>213</sup> Now the ability of web-based automation to track a replacement part from the United States directly to the receiving unit has enabled 'inventory-in-motion' and thus the reduction of massive warehouses in theater, like during COBRA, and a better linkage between operational and tactical logistics.

With army transformation, medical care, known as army health services, has become force health protection and health service support. The focus of force health protection is on the tactical medical mission.<sup>214</sup> During transformation, the maneuver battalion medical platoon did not move to the forward support company along with the support platoon and the battalion maintenance assets. Thus, the battalion medical platoon along with combat lifesavers are still level I medical care, formally known as echelon I. Combat lifesavers or medics evacuate casualties to the battalion aid station and thence to

---

<sup>212</sup>*Sustainment in the Theater of War*, 6-19 – 6- 21.

<sup>213</sup>*Ibid.*, 6-17.

<sup>214</sup>*Sustainment*, 5-20 – 5-21.

the brigade support battalion's brigade support medical company via the company's ground ambulance or a supporting air ambulance. The brigade support medical company, often augmented with a forward surgical team, provides level II care which includes level I plus the addition of dental, laboratory, preventive medical, radiology, blood management, and combat stress control capabilities.<sup>215</sup> The army health system could evacuate a soldier requiring greater care to a combat support hospital (level III) or a theater medical treatment facility (level IV) such as Landstuhl. Convalescent and restorative care is level V and is located at a treatment facility in the continental United States.<sup>216</sup> The movement of a casualty looks similar but the speed at which a soldier can move from tactical-level care to theater-level care is remarkable since COBRA or even DESERT STORM.

The division G4 has just as essential a role today as he did during DESERT STORM or COBRA, perhaps even more. The G4 is responsible for establishing logistics priorities within the division, conducting sustainment planning, monitoring readiness of the brigades, and maintaining the logistics common operating picture for the division. Without the help of a colonel commanding a division support command, as well as his staff, "resources must still be allocated, priorities must still be set, and key sustainment determinations and decisions must still be made."<sup>217</sup> The G4 staff section has four branches: maintenance, supply and services, transportation, and logistics automation as

---

<sup>215</sup>*Sustainment in the Theater of War*, 6-26 - 6-28.

<sup>216</sup>*Combat Service Support Battle Book* (Ft. Leavenworth: U.S. Command and General Staff College, 2007), 4-25 – 4-26. The army had deactivated all field and mobile hospitals by 2009. Only CSH remain.

<sup>217</sup>*Sustainment in the Theater of War*, 5-1.

well as other logisticians serving throughout the division headquarters.<sup>218</sup> Now that divisions may serve as a joint task force at the operational level of war, the division G4 may become the first operational-level logistician in a theater.

**Results: what should have happened and what happened<sup>219</sup>**

Military planners make assumptions which are valid and necessary to continue the planning process. The author has made a number of assumptions for Operation GREEN DAWN. There will not be large stockpiles of equipment within the joint operating area; only very limited host nation support will be available; contractors will be present but not in overwhelming numbers; and finally since this is a maneuver operation, the placement of fixed fuel bags will not be capable of supporting the operation.

Not running out of fuel has been and probably will continue to be one of the greatest concerns of commanders and logisticians conducting offensive operations. During each day of offensive operations, each heavy brigade would consume 84,000 gallons of fuel; the infantry brigade combat team would consume 22,000 gallons, and the fires brigade would consume 44,000 gallons. With the combat aviation brigade consuming 107,000 gallons per day, the aggregate total for the division would be 423,000 gallons of fuel consumed per day.<sup>220</sup> This equates to 1.25 million gallons of fuel for the 1<sup>st</sup> Infantry Division during the three day operation! Fought anywhere other than the oil rich sands of southern Iraq and Kuwait, this would be the limiting factor by itself.

---

<sup>218</sup>Ibid., 5-2 – 5-4.

<sup>219</sup>See Appendix J for the logistical results, consumption data, usage rate, loss rates, and operational readiness rates.

<sup>220</sup>*Combat Service Support Battle Book*, 4-5 – 4-9.

However, with throughput from the operational level logistics system, the logistics system should be able to keep pace with fuel consumption rates for the heavy brigade combat team. At the operational level, the sustainment brigade would require a minimum of two POL truck companies to support the division for three days in maneuver operations.<sup>221</sup>

If a critical shortage of fuel or ammunition developed, although the 1<sup>st</sup> Infantry Division had priority of support from the expeditionary sustainment command, without his own logistics assets, the division commander had no divisional units to provide emergency resupply. The type of operation and the intensity of combat determine ammunition consumption factors. Each heavy brigade in the attack consumed sixty-two short tons, the infantry brigade consumed seven short tons, the fires brigade consumed 1,200 short tons and the combat aviation brigade consumed six short tons. The division consumed nearly 4,200 short tons of class V for the three day offensive.<sup>222</sup> Assuming support systems (e.g. cargo trucks) are lost at a ten percent rate in offensive operations, the logistics system can handle requirements for the heavy brigade combat team in the attack. At the end of three days of offensive operations, the brigade would require 186 short tons while the brigade support battalion's trucks could deliver an impressive 312 short tons even after three days of ten percent losses. One critical assumption though is that these trucks are only hauling ammunition and not all the other supply

---

<sup>221</sup>Two competing assumptions nullify each other in these equations: the fuel trucks operate at a 100 percent readiness rate and the number of vehicles requiring fuel stays at a 100 percent readiness rate (i.e. there are no losses).

<sup>222</sup>*Combat Service Support Battle Book*, 4-9 – 4-14. A short ton is 2,000 pounds.

requirements.<sup>223</sup> The logistics system is capable of supporting ammunition requirements for maneuver operations, but the throughput by the operational level was critical in resupplying units with their ammunition. Unfortunately, throughput is not applicable to maintenance support.

The tactical level logistics system focuses on field maintenance while the operational level concentrates on sustainment maintenance. The division commander probably hoped for another field maintenance unit to repair and return equipment to his division, like during Operation COBRA. Maintenance planning data estimates a loss rate, i.e. damaged or destroyed, of eighteen percent for M1 Abrams tanks and twenty-two percent for M2/M3 Bradley infantry fighting vehicles. Of those damaged, eighty percent are repairable. However, mechanics are only able to repair slightly more than half at the field maintenance level. Thus after twenty-four hours in the attack, a typical combined arms battalion with thirty tanks could have the following status: two tanks destroyed, two tanks in field maintenance with the forward support company at the brigade support area, and two tanks in sustainment maintenance back with the sustainment brigade.<sup>224</sup> Once those tanks went to sustainment maintenance however, they might not return to the brigade. Once repaired sustainment maintenance would turn them into the supply systems for the next requisition. In this scenario, that would mean right back to the nearest customer, the 1<sup>st</sup> Infantry Division; however, the limiting factor here is the time required

---

<sup>223</sup>Greater than three days this would probably not be a valid assumption. See note about truck usage from World War II division historian.

<sup>224</sup>*Combat Service Support Battle Book*, 4-14 – 4-16.

in sustainment maintenance to repair the tank.<sup>225</sup> There are two combined arms battalions for a total of sixty tanks in each brigade. After three days of offensive operations, the brigade would only have forty-one out of sixty tanks left on the battlefield, a dangerous operational readiness rate of sixty-eight percent. The logistics system would have difficulty sustaining adequate class VII, major end item, resupply to the heavy brigade during maneuver operations. Our logistics concept of just-in-time support works for small class IX repair parts. It is very difficult to fly in a seventy ton tank to issue to a unit just in time to conduct operations. Although the brigade support battalions in each of the brigades could receive additional support maintenance companies, the division headquarters does not directly control a logistics headquarters which could receive these attachments. If these companies are in the area, they are only providing general support which means the sustainment brigade, not the division, sets their priorities.

The medical system functioned very similarly to DESERT STORM. Now that every combat aviation brigade has an air medical evacuation company, this capability is available to nearly every casualty on the battlefield. On the first day of GREEN DAWN, the author determined that the division would have sustained 140 casualties during the breaching operation and 795 casualties during the subsequent offensive. The division would have suffered 381 casualties on the second day and 374 on the third.<sup>226</sup>

Besides fuel, ammunition, maintenance, and medical, there were other logistics considerations. One concern was transportation. With the divisional truck company deactivated, and no sustainment assets at the division level, the 1<sup>st</sup> Infantry Division was

---

<sup>225</sup>More than likely these tanks would be shipped back to the United States for sustainment maintenance.

<sup>226</sup>*Combat Service Support Battle Book*, 4-23 – 4-25.

not able to provide their infantry brigade combat team with truck assets to make them more mobile. They would not be able to keep up with the speed of the heavy brigade combat teams.

In 2012, the army must still be able to conduct and logisticians must still be able to sustain operational maneuver. Operation GREEN DAWN has shown that our logistics architecture is still capable of sustaining maneuver despite large requirements for fuel and maintenance support. Planners might still need to incorporate operational pauses but technology has aided logistics capability and the power of the brigade combat team is unequalled. However, operational level maneuver commanders (division and corps) have less control over their own logistics – thus further complicating the sustainment architecture of the early twenty-first century.

## **CONCLUSION**

Can the United States Army sustain operational maneuver in the twenty-first century? Yes, however there are still things to improve and refine. The army should employ lessons learned from Operations COBRA and DESERT STORM to help sustain operational maneuver in the future. There are four factors which affect support to operational maneuver which the army must address. Transformation was an evolutionary process; however, for logisticians and maneuver commanders it has complicated unity of command and unity of effort at the operational level of war. After analyzing the principles of sustainment in relation to these operations, the author recommends the army should consider subsequent improvements to our logistics architecture.



## **The principles of sustainment**

There are eight principles of sustainment. They are integral to extending operational reach and maintaining combat power. The most essential principle is integration: the combination of sustainment with operations to ensure unit of effort and purpose. Anticipation is the use of professional judgment to foresee future events and to prepare appropriate responses for them. Responsiveness itself is the ability to meet rapidly changing requirements in a short period of time. Simplicity aims to reduce the complexity of sustainment. Economy focuses on the most efficient use of assets for the greatest effect possible. Survivability is the capability to protect people and assets from destruction. Continuity is seamless provision of logistics across the strategic, operational, and tactical levels of war. Finally, improvisation is the capability to rapidly adapt to unexpected circumstances. These principles are both independent and interrelated.<sup>227</sup> They offer a subjective assessment for the success of logistics in supporting Operations COBRA, DESERT STORM, and GREEN DAWN.

One can apply the principles of sustainment retroactively to logistics operations during Operation COBRA. Integration, defined as the union of logistics tasks, functions, systems, processes, and organizations, appeared successful. No units failed in their mission because of logistics; similarly logistics units performed their function mostly in accordance with doctrine. Anticipation was evident in the large amount of operational level stocks prepared in the army depots. Responsiveness is the ability to meet rapidly changing requirements on short notice. Operation COBRA did not really test or tax this system in this area. Simplicity – striving to minimize complexity--was not evident in the

---

<sup>227</sup>*Sustainment*, 1-1 to 1-3.

confusion and complexity between the Communications Zone and the Advanced Section which was supposed to be just another part of the former headquarters. Economy--providing resources in an efficient manner--was not a main concern of logisticians because of the mass quantities of supplies and the mostly 'push' logistics system. Survivability--the protection of assets and materiel--was marginally successful. In some cases combat units closely escorted resupply convoys; also there was little or no danger of enemy air attacks against supply depots. Continuity requires commanders to eliminate backlogs or bottlenecks. Unfortunately, for some time all the supplies had to come over the Normandy beaches creating a huge bottleneck for the logisticians. Finally, improvisation--the ability to adapt sustainment operations to unexpected changes--was certainly present. The ordnance corps installed over 500 "rhinoceros attachments" to tanks in preparation for breaking through the hedgerows.<sup>228</sup> Also, some logistics leaders augmented their units with additional personnel (e.g. the quartermaster company).

During Operation COBRA, of the four problem areas which affect the interaction of operational and tactical levels of logistics, the first, the union of current doctrine and leadership succeeded in clearly identifying command and support relationships at the tactical and operational levels. Units knew who provided their sustainment and where to receive their support from. The fact that there were a number of leaders who wore two hats as staff officers probably aided this. Second, there was neither adequate nor robust logistics structure at the division level. After World War II, the Army greatly expanded the division logistics structure. Third, there was an inordinate focus on the short, decisive battle. Operation COBRA was over in about a week. From that point on the rapid

---

<sup>228</sup>Mansoor, 164.

advance greatly exceeded operational logistics plans. The failure to plan for appropriate logistics at the operational level was the limiting factor in slowing the Allied advance. Fourth, although the logistics structure at the tactical level was appropriate, doctrine was flawed. Units drove over 100 miles to army supply depots when doctrine stated 30 miles were correct.<sup>229</sup>

One can also retroactively apply the principles of sustainment to Operation DESERT STORM. Most were well represented and very successful. Integration was clearly present as the concept of support was nested with the concept of operations at all levels and units were attached or in direct support in accordance with doctrine. The 22<sup>nd</sup> SUPCOM anticipated future requirements by preparing large logistics bases in the desert to support the advance. The forward support battalions were truly responsive to their respective maneuver brigades providing up close and personal logistics assets to the maneuver commanders, often just in time. Simplicity was evident through clearly defined command relationships at the tactical and operational levels--attached units or ones in direct support understood their roles. Logisticians did not follow the economy principle of sustainment. DESERT STORM was still logistics by brute force. Since there was nearly a complete absence of enemy air aircraft, operations did not especially tax survivability. However, there were large pockets of armed Iraqis milling about in the rear areas. Operations did strain continuity--the uninterrupted provision of sustainment across all levels. Had the offensive continued was there a possibility that it might have reached a culmination point? Operational logistics might not have been able to sustain the maneuver with repair parts or adequate fuel. The support command for 1<sup>st</sup> Infantry

---

<sup>229</sup>Mansoor, 176-180.

showed the ability to improvise by having an emergency, mobile logistics element of POL, water, and rations. In the end, Lieutenant General Franks said VII Corps was successful because of “brute force logistics”--it might not be neat but there was enough mass to get the job done.<sup>230</sup>

Of the four factors which affect the interaction between operational level and tactical level logistics during DESERT STORM, three were positive and added to the seamlessness of logistics support to operational maneuver. First, command and control relationships, which units did not always rigidly follow, were well known and clearly identified. Logistics units that train with their combat arms units in peace will support better in war. This worked for the forward support battalions but not as well for the corps support groups. Second, there was a large, robust, and responsive support command as well as a support group providing direct support. All of these assets at the division and corps level ensured a seamless interface between operational and tactical logistics. Third, there was a risk that had the war lasted greater than 100 hours or if the pursuit was longer in distance, the logistics system would not have been able to support these units. Soldiers were fatigued, friction was high, and the fog of war was omnipresent: e.g. there are a finite number of times that a leader can launch a ‘superhuman effort’ to look for fuel trucks. Finally, although the forward support battalions were relatively lean; they received direct augmentation from corps units to help accomplish their mission. The problem with the forward support battalion concept as Lieutenant Colonel Buffington stated was the desires of the brigade commander and the support command commander

---

<sup>230</sup>Lieutenant Colonel Charlotte E. Kimball “A small part of the whole...a large part of me,” in *Personel Perspectives on the Gulf War* (Arlington: Association of the United States Army, 1993), 59.

were not always the same. Often he had to “balance the two and keep some type of harmony between the two organizations.”<sup>231</sup> Overall, three of the four factors affecting the interplay between operational and tactical logistics were positive, thus making Operation DESERT STORM one of the best examples of sustaining operational maneuver in the twentieth century.

Again, one can apply the principles of sustainment against Operation GREEN DAWN to determine relevancy to future actions. Integration is present in the logistic system but is lacking in the cross over at the operational level. The army best achieves deliberate coordination and synchronization through a command relationship not a support relationship (e.g. sustainment brigades attached versus in general support). Logistics planners need to build ability to anticipate into the logistics architecture. Situational surprises are always possible with the fog and friction on the battlefield. At the tactical level; logistics responsiveness was immediate. An organic brigade support battalion which trained all the time with its brigade absolutely understood the brigade’s mission and was not bifurcated between two masters. On the contrary, operational level logisticians failed to achieve simplicity. It includes “clarity of tasks, standardized and interoperable procedures, and clearly defined command relationships.”<sup>232</sup> The confusion and complication occurs when two maneuver commanders of equal rank (e.g. division commanders) both require support. Luckily in GREEN DAWN the planners provided each division with a sustainment brigade in general support. With an army built on in-transit visibility, inventory in motion, and just in time logistics, economy was a

---

<sup>231</sup>Buffington, 40.

<sup>232</sup>*Sustainment*, 1-3.

sustainment value well represented. But cheapness or economy does not win wars. The ability to survive on the battlefield does; continued advancements in technology increase survivability for logisticians and support vehicles. Continuity would only have been lost if the offensive culminated. Improvisation has been and will always be one of the great strengths of the American military. In the case of GREEN DAWN, massive strategic airlift could have provided emergency resupplies as well as evacuation of casualties.

The four factors affecting operational and tactical logistics evident in Operation GREEN DAWN were not as positive as during DESERT STORM. Current doctrine says operational level commanders should develop a “collaborative environment” and use coordination to support maneuver commanders.<sup>233</sup> This obviously fails to identify a clear command and support relationship at the operational level. For instance, the expeditionary sustainment commander works for the theater and needs to develop an amorphous “collaborative environment” with the corps and division commanders. The second factor is the greatest problem – there is a distinct lack of logistics organization at the division level. Our current doctrine identifies this as a risk too. “Neither the corps nor the division has any organic assets to assemble and maintain logistical reserves to meet unforeseen problems.”<sup>234</sup> An attempt to rely on the sustainment brigade providing general support “may conflict with other priorities and may exceed the sustainment brigade’s capabilities.”<sup>235</sup> Thus the operational maneuver commander is limited in his ability to immediately reinforce and sustain success or react to an opportunity. The third factor –

---

<sup>233</sup>*The Sustainment Brigade*, 1-7.

<sup>234</sup>*Sustainment in the Theater of War*, 5-8

<sup>235</sup>*Ibid.*

the focus on the short, decisive battle was the American way of war for the past thirty years. Only the future will tell if the U.S. Army's extended operations in Iraq and Afghanistan has changed its culture to focus on longer campaigns. Finally, there is a minor, residual problem of organizational structure at the tactical level. Although the brigade support battalions are organic elements of the brigade, different battalions have different command relationships with the forward support companies – the army needs to make a uniform policy for these relationships.

### **Success at the tactical level**

Task organization is a recurring challenge. Sometimes the army cuts back too much on the sustainment tail that it throws off balance the whole machine. After World War II, the army listened to its combat leaders and got the logistics structure right by using the heavy armored division logistics organization as the structure which eventually morphed into the Army of Excellence with three forward support battalions. Also, the assigned service companies which were in each tank or armored infantry battalion are similar to today's forward support companies. However, as was addressed in the notional case study, the army has cut too far back on the divisional logistics structure leaving the division commander with the ability to neither control sustainment in his division nor weight the main effort with extra logistical assets. The army could attach units to each brigade support battalion. However, at the divisional level, lack of a logistics headquarters might hinder the division headquarters from providing appropriate command and control to logistics units which the army might attach to the division. During Operations COBRA and DESERT STORM, the army attached echelon above corps logistics units directly to divisions to provide added support since the divisions did

not have enough assets to accomplish their sustainment missions. The 1<sup>st</sup> Infantry Division received attachment of quartermaster units, ordnance units, transportation units, and medical units. It was able to appropriately command and control these units because it had adequate logistics headquarters and divisional companies. The army needs to address this today with a divisional logistics structure.

Fuel is always a critical issue for maneuver operations. The internal combustion engine was one of the greatest inventions of the twenty-century. However, to run its engine, the M1 Abrams tank requires nearly a fifty-five gallon drum of fuel per hour. To truly save weight and maintain sustainability the army should experiment with other fuel sources. In current operations, the use of static fuel bags and somewhat moveable blivets is ubiquitous. These would not be as easy to move during maneuver operations. Logisticians need to have more fuel cans on hand during fast moving maneuver operations especially since fuel bags once placed on the ground are difficult to reposition.<sup>236</sup> In the meantime, defense scientists need to continue research on practical alternatives for conventional fuel or hybrid vehicles like the experimental support vehicles in Operation GREEN DAWN. In a recent article in *Joint Force Quarterly*, Amory Lovins, the Chief Scientist of the Rocky Mountain Institute posits that a lean or non-existent fuel tail will rapidly increase operational maneuver and mobility. He

---

<sup>236</sup>McGee, 34. The 102<sup>nd</sup> Infantry Division during World War II normally carried an impressive 2,200 cans with its quartermaster company (about 11,000 gallons). At the very least, fuel cans could be changed from a durable to a consumable supply item. There are three main types of items in the army supply: non-expendable, durable, and expendable/consumable.



forecasts that “the biggest gains in combat effectiveness will come from fuel-efficient ground forces.”<sup>237</sup>

Ammunition, and the problems of supplying it, was an excellent lesson learned during CORBA and continues to be a success. We have a push system now instead of a pull system. Also, instead of shipping rounds break-bulk and letting those rounds sit in brackets in the backs of trucks or trailers, now the logistics system delivers artillery class V right to a location in a container.<sup>238</sup> This was the main reason for the development of the palletized load system at the end of the twentieth century.<sup>239</sup> However, the artillery officers of the 1940s appeared frustrated by having to report requirements to the division G4 which became not much more than a middleman tracking cell. This may be a warning of other subject areas where the G4 risks becoming just a visibility cell.

Maintenance continues to be a success, yet there may still be some lessons to re-learn. Most division commanders (whether in the 1940s or 2010s) will want their equipment repaired ‘in house.’ The two-level maintenance system has simplified maintenance support and provided more assets to the brigades. Yet without a division maintenance company, the division staff cannot order additional maintenance assets to support the division commander’s objectives. There is a risk about being too lean on maintenance. Initially when the army introduced the Future Combat System, the army felt it would be able to add more manpower to the infantry units since a common chassis

---

<sup>237</sup> Amory B. Lovins, “DOD’s Energy Challenge as Strategic Opportunity” *Joint Force Quarterly*, no. 57 (2<sup>nd</sup> Quarter, 2010): 36-37.

<sup>238</sup> Sayen, 51.

<sup>239</sup> *Sustainment in the Theater of War*, 6-16.

required less mechanics.<sup>240</sup> Whether it was Lieutenant General McNair's plan to lean down the division or it was the army's plan in Future Combat System to create more combat forces at the expense of mechanics and logistics soldiers, the tooth-versus-tail argument is also still alive and well.

Medical support to sustaining operational maneuver is probably the army's greatest success. Advances in medical technology and evacuation have been both evolutionary and revolutionary. Perhaps the only issue to address here is the proper location of the battalion medical platoons. Should they be an organic part of the forward support company like the medical company is an organic part of the brigade support battalion? The army should continue to analyze and research this issue.

Finally, transportation has always been the linchpin to the army's logistics system. From Operation COBRA to Operation IRAQI FREEDOM, the army has attached or OPCON truck companies to infantry divisions in order to help move soldiers on the battlefield and to 'motorize' the unit. In some ways transformation has been a transportation success. The army now has fully motorized heavy brigade combat teams. There is enough space for every soldier to ride in a vehicle.<sup>241</sup> In solving one problem, the army created another by disbanding the divisional truck company. It had controlled truck assets which could have provided transportation to the division. While this may have motorized the division, it fails to take into account the other uses of a centralized, organic division transportation unit. The G4 for the 102<sup>nd</sup> Infantry during World War II presents a brief list of uses: "The G1 required trucks to take men to rest centers or baths;

---

<sup>240</sup>The project manager briefed the FCS program to the author in ILE. He stated the additional infantry positions would come from maintenance personnel no longer needed.

<sup>241</sup>Only the HBCT and the SBCT are 100 percent mobile, the IBCT is not.

G2 needed transportation for moving prisoners of war and wanted political personnel; G3 demanded trucks to motorize dismounted elements of the divisions; and G4 continually received calls for trucks for countless reasons.”<sup>242</sup> There is a clear lesson learned here which we are forgetting today: once you distribute truck assets down to a lower unit, you lose the ability to pool them for other operations.

### **Recommendations for the operational level**

The author believes one can extrapolate a number of recommendations from these case studies. First, the division commander has no logistics assets at his immediate command. Thus, the army should assign a sustainment brigade headquarters to every division. This brigade headquarters would command and control at least one combat sustainment support battalion. This would allow for the division commander to logistically weight his main effort as well as provide a battalion headquarters to receive logistics units attached to a division such as transportation companies (always in need when conducting operational maneuver), support maintenance companies (to increase the division’s operational readiness rate), and POL companies (to provide fuel in order to avoid a culmination point in the offense). The sustainment brigade would also control its organic brigade troops battalion as well as the division’s special troops battalion, which currently does not have a brigade commander in the rating chain. If a maneuver enhancement brigade was not available, a sustainment brigade could command an engineer battalion just like in some garrisons. This would also provide an O6 logistics commander and his staff to provide logistics recommendations and planning support to

---

<sup>242</sup>McGee, 36.

the division commander and his staff. There are enough sustainment brigades in the active army to align one per division and leave three to serve under the theater sustainment commands as theater brigades. There are nineteen sustainment brigades in the reserves--more than enough to serve as theater brigades. These would be available for a major theater war.<sup>243</sup>

Second, if the army does not develop the above mentioned organizational structure, the army should firmly and clearly specify when sustainment brigades are in direct support to a division. In current doctrine sustainment brigades do not provide direct support nor are they attached to a division, they only provide general support to a division.<sup>244</sup> Often during Operations IRAQI FREEDOM and ENDURING FREEDOM sustainment brigades, which were co-located in garrison with their historical divisions, deployed to war and fell under an expeditionary sustainment command while still maintaining some type of a habitual relationship with the earlier division. While a general support relationship may be adequate for stability operations, it is not adequate to sustain rapid maneuver warfare over extended distances. The direct support relationship – where the supported commander establishes the priorities of the supporting unit and positions it on the battlefield--would allow for sustainment brigades to cut through the fog and friction in mounted operations to adequately and appropriately sustain a division in maneuver warfare.

Third, the army should translate current doctrine reflecting the *Multi-Functional Logistics Concept* (version 6) into the Field Manual 4-0 series rather than allowing it to

---

<sup>243</sup>*Logistics Force Structure Book*, 38-39.

<sup>244</sup>*The Sustainment Brigade*, 1-5.

exist as a stand-alone document from the Combined Arms Support Command. No one can find this on the web if they did a generic search for 'how the army does logistics.' It is not even in the General Reimer library. Additionally, the army should publish doctrine manuals on the role, organization, mission, and functions of the combat sustainment support battalion and the brigade support battalion. We have individual field manuals on parachute rigging certain types of vehicles but no published doctrine about these units.

Fourth, the expeditionary sustainment command headquarters which replaced the corps support command headquarters is actually smaller than the latter which portends a lack of capability. This could be a great risk if the army engages in operational maneuver with multiple divisions or corps. "The sheer size of such a theater and the magnitude of the support function may overwhelm the ESC."<sup>245</sup> Thus, the army should make the expeditionary sustainment command an actual operational command post of the theater sustainment commands--i.e. the ESC needs to be an assigned component of the theater sustainment command. These personnel should be wearing the same patch and on the same team. This would allow for a more seamless logistics operation and less contention between these two commands. For example, logisticians within the 13<sup>th</sup> ESC, currently deployed to Iraq, stated in an interview with Center for Army Lessons Learned, "we would like to have more of an active role in controlling our doctrine rather than having it controlled by 1<sup>st</sup> TSC in Kuwait, with them being so far away from the fight."<sup>246</sup> The army was supposed to be reducing redundancy, but it seems like the expeditionary sustainment command is adding a layer back. It would be better for the expeditionary

---

<sup>245</sup>*Sustainment in the Theater of War*, 5-8.

<sup>246</sup>Interview with LTC Rich Tate and LTC Elizabeth Delbridge (September 02, 2009), 12.

sustainment command to serve as a deployable operational command post of the theater sustainment command rather than as its own command.

### **Concluding comments**

The ultimate goal of logistics should be to generate combat power at the decisive point. In an attempt to improve how our logistics architecture sustains and supports the army at the operational and tactical levels of war, the author looked at two historical case studies which offered lessons learned for how to conduct and organize logistics today. The pinnacle of a functioning logistics system at the operational / tactical level was during Operation DESERT STORM. However, seams existed there which were deepened during Operation IRAQI FREEDOM. Senior logistician's concerns over these seams were the driving impetus to changes in the sustainment concept and organization in the modular force. Operation GREEN DAWN posits that the army can continue to sustain operational maneuver however, there are still relevant lessons from Operations COBRA and DESERT STORM. As we look forward to the future we would do well to remember the past. The challenges of sustaining operational maneuver will still be difficult as long as soldiers of flesh and blood maneuver for terrain, fight with bullets, and drive vehicles powered by an internal combustion engine.

## APPENDICES

### Appendix A: Table B-2 Command and Support Relationships

**Table B-2. Command relationships**

If relationship is:	Then inherent responsibilities:																															
	Have command relationship with:	May be task-organized by: <sup>1</sup>	Unless modified, ADCON responsibility goes through:	Are assigned position or AO by:	Provide liaison to:	Establish/maintain communications with:	Have priorities established by:	Can impose on gaining unit further command or support relationship of:																								
Organic	All organic forces organized with the HQ	Organic HQ	Army HQ specified in organizing document	Organic HQ	N/A	N/A	Organic HQ	Attached; OPCON; TACON; GS; GSR; R; DS																								
Assigned	Combatant command	Gaining HQ	Gaining Army HQ	OPCON chain of command	As required by OPCON	As required by OPCON	ASCC or Service-assigned HQ	As required by OPCON HQ																								
Attached	Gaining unit	Gaining unit	Gaining Army HQ	Gaining unit	As required by gaining unit	Unit to which attached	Gaining unit	Attached; OPCON; TACON; GS; GSR; R; DS																								
OPCON	Gaining unit	Parent unit and gaining unit; gaining unit may pass OPCON to lower HQ <sup>1</sup>	Parent unit	Gaining unit	As required by gaining unit	As required by gaining unit and parent unit	Gaining unit	OPCON; TACON; GS; GSR; R; DS																								
TACON	Gaining unit	Parent unit	Parent unit	Gaining unit	As required by gaining unit	As required by gaining unit and parent unit	Gaining unit	TACON; GS; GSR; R; DS																								
<p><b>Note:</b> <sup>1</sup> In NATO, the gaining unit may not task-organize a multinational force. (See TACON.)</p> <table style="width: 100%; border: none;"> <tr> <td style="width: 50%;">ADCON</td> <td style="width: 40%;">administrative control</td> <td style="width: 5%;">HQ</td> <td style="width: 45%;">headquarters</td> </tr> <tr> <td>AO</td> <td>area of operations</td> <td>N/A</td> <td>not applicable</td> </tr> <tr> <td>ASCC</td> <td>Army Service component command</td> <td>NATO</td> <td>North Atlantic Treaty Organization</td> </tr> <tr> <td>DS</td> <td>direct support</td> <td>OPCON</td> <td>operational control</td> </tr> <tr> <td>GS</td> <td>general support</td> <td>R</td> <td>reinforcing</td> </tr> <tr> <td>GSR</td> <td>general support–reinforcing</td> <td>TACON</td> <td>tactical control</td> </tr> </table>									ADCON	administrative control	HQ	headquarters	AO	area of operations	N/A	not applicable	ASCC	Army Service component command	NATO	North Atlantic Treaty Organization	DS	direct support	OPCON	operational control	GS	general support	R	reinforcing	GSR	general support–reinforcing	TACON	tactical control
ADCON	administrative control	HQ	headquarters																													
AO	area of operations	N/A	not applicable																													
ASCC	Army Service component command	NATO	North Atlantic Treaty Organization																													
DS	direct support	OPCON	operational control																													
GS	general support	R	reinforcing																													
GSR	general support–reinforcing	TACON	tactical control																													

Source: Field Manual 3-0: *Operations* (Washington, D.C.: U.S. Government Printing Press, 2008), B-10.

**Appendix B – Table B-3: Army Support Relationships**

If relationship is:	Then inherent responsibilities:							
	Have command relationship with:	May be task-organized by:	Receives sustainment from:	Are assigned position or an area of operations by:	Provide liaison to:	Establish/maintain communications with:	Have priorities established by:	Can impose on gaining unit further command or support relationship by:
Direct support <sup>1</sup>	Parent unit	Parent unit	Parent unit	Supported unit	Supported unit	Parent unit; supported unit	Supported unit	See note <sup>1</sup>
Reinforcing	Parent unit	Parent unit	Parent unit	Reinforced unit	Reinforced unit	Parent unit; reinforced unit	Reinforced unit; then parent unit	Not applicable
General support–reinforcing	Parent unit	Parent unit	Parent unit	Parent unit	Reinforced unit and as required by parent unit	Reinforced unit and as required by parent unit	Parent unit; then reinforced unit	Not applicable
General support	Parent unit	Parent unit	Parent unit	Parent unit	As required by parent unit	As required by parent unit	Parent unit	Not applicable

**Note:** <sup>1</sup> Commanders of units in direct support may further assign support relationships between their subordinate units and elements of the supported unit after coordination with the supported commander.

Source: Field Manual 3-0: *Operations* (Washington, D.C.: U.S. Government Printing Press, 2008), B-11.



## Appendix C – Map of 1<sup>st</sup> ID (COBRA)

Figure 9.1 Attack of the 1st Infantry Division

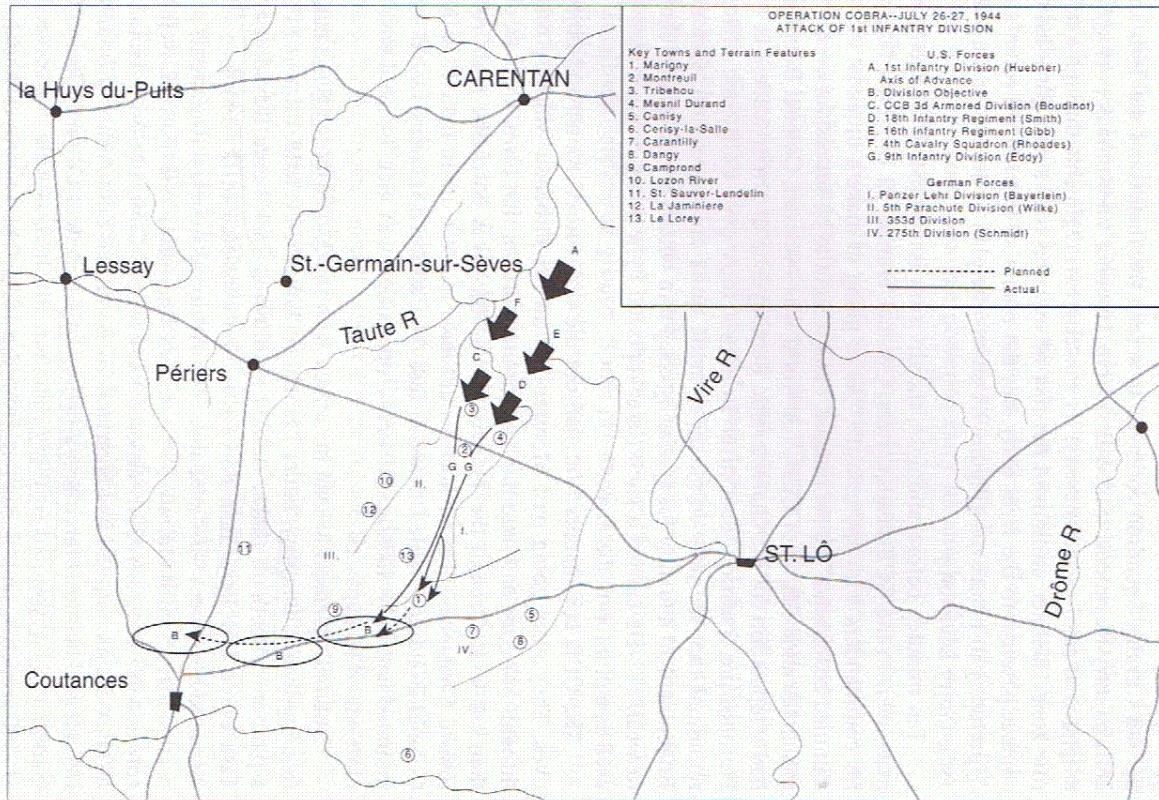

Source: James Jay Carafano, *After D-Day: Operation Cobra and the Normandy Breakout* (Boulder: Lynne Rienner Publishers, Inc., 2000).

Appendix D – TO&E for new Infantry Division (July 1943)

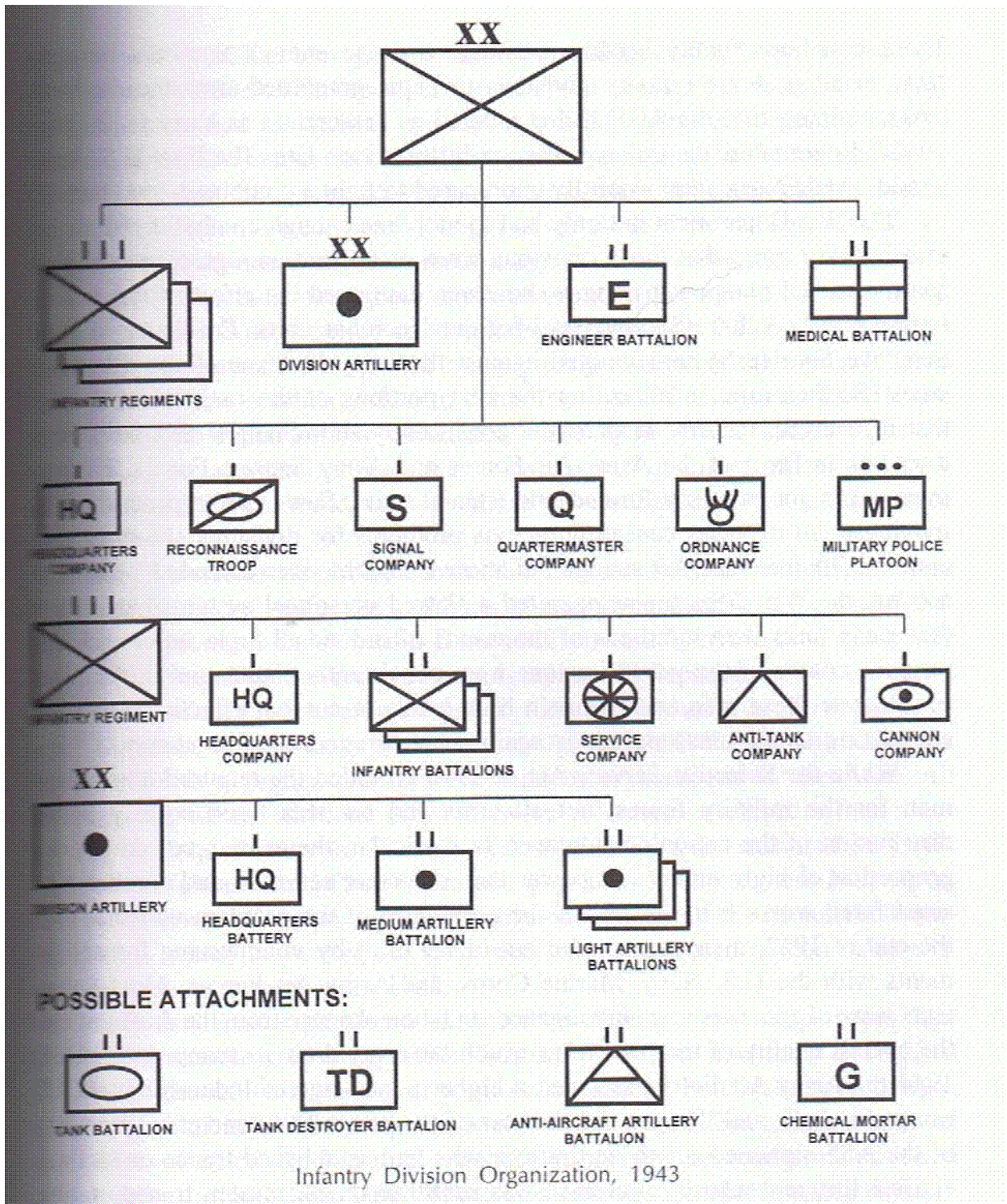

Source: Peter R. Mansoor, *The GI Offensive in Europe: The Triumph of American Infantry Divisions, 1941-1945* (Lawrence: University of Kansas Press, 1999), 39.



## Appendix E – Task Organization of 1<sup>st</sup> ID (COBRA)

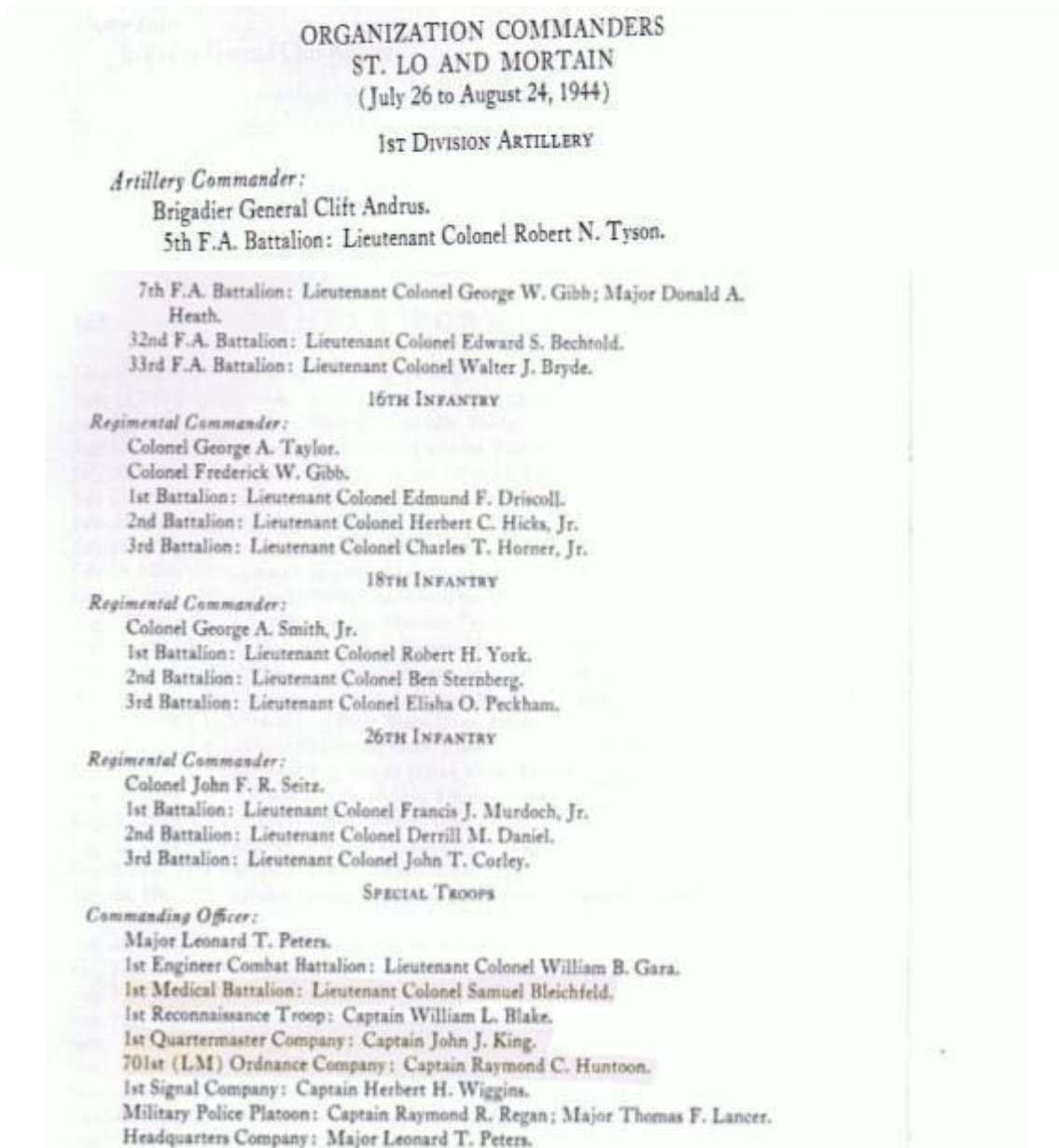

Source: H.R. Knickerbocker, *Danger Forward: The Story of the First Division in World War II* (Atlanta: Albert Love Enterprises, 1947), 413-414.

## Appendix F – Photograph of army supply depot



HOUSEKEEPING. To feed, clothe and take care of the endless and innumerable articles, small and large, a soldier needs, the Quartermaster operated giant warehouses (above), and used thousands of trucks to deliver the goods of war (below).



Source: Randolph Leigh, *48 Million Tons to Eisenhower: The Role of the SOS in the Defeat of Germany* (Washington, D.C.: The Infantry Journal, 1945), 169.

## Appendix G – Task Organization for 1<sup>st</sup> ID (DESERT STORM)

1st Infantry Division (Mechanized)	Maj. Gen. Thomas G. Rhame
2d Battalion, 3d Air Defense Artillery	Lt. Col. Clifford G. Willis
1st Engineer Battalion	Lt. Col. Stephen Hawkins
101st Military Intelligence Battalion	Lt. Col. Rodney (Bill) Moore
1st Military Police Company	Capt. Robert F. Nelson
121st Signal Battalion	Lt. Col. Gary Bushover
12th Chemical Company	Capt. Vance E. Visser
1st Brigade	Col. Lon E. Maggart
5th Battalion, 16th Infantry	Lt. Col. Sydney F. (Skip) Baker
1st Battalion, 34th Armor	Lt. Col. G. Patrick Ritter
2d Battalion, 34th Armor	Lt. Col. Gregory Fontenot
2d Brigade	Col. Anthony Moreno
2d Battalion, 16th Infantry	Lt. Col. Daniel R. Fake
3d Battalion, 37th Armor	Lt. Col. David F. Gross
4th Battalion, 37th Armor	Lt. Col. David W. Marlin
3d Brigade (2d Armored Division Forward)	Col. David Weisman
1st Battalion, 41st Infantry	Lt. Col. James L. Hillman
2d Battalion, 66th Armor	Lt. Col. John Sloan Brown
3d Battalion, 66th Armor	Lt. Col. G. Taylor Jones
Aviation Brigade	Col. James Mowery
1st Squadron, 4th Cavalry	Lt. Col. Robert Wilson
1st Battalion, 1st Aviation	Lt. Col. Ralph Hayles
	Lt. Col. Ronald Richelsdorfer
4th Battalion, 1st Aviation	Lt. Col. Philip Wilkerson
Company F, 1st Aviation	Maj. Tom Porter
1st Infantry Division Artillery	Col. Michael Dodson
1st Battalion (155-mm. SP), 5th Field Artillery	Lt. Col. Harry Emmerson
4th Battalion (155-mm. SP), 5th Field Artillery	Lt. Col. John R. Gingrich
4th Battalion (155-mm. SP), 3d Field Artillery	Lt. Col. Robert L. Smith
Battery B (MLRS), 6th FA	
Battery D (TAB), 25th FA	
1st Infantry Division SUPCOM	Col. Robert Shadley
101st Support Battalion (Forward)	Lt. Col. Edwin L. Buffington, Jr.
201st Support Battalion (Forward)	Lt. Col. William Hand
498th Support Battalion (Forward)	Lt. Col. Stephen J. Marshman
701st Support Battalion (Main)	Lt. Col. Lloyd T. Waterman

Source: Stephen A. Bourque *Jayhawk! The VII Corps in the Persian Gulf War* (Washington, D.C.: Department of the Army, 2002), 467.



## Appendix H – Map of Operation DESERT STORM

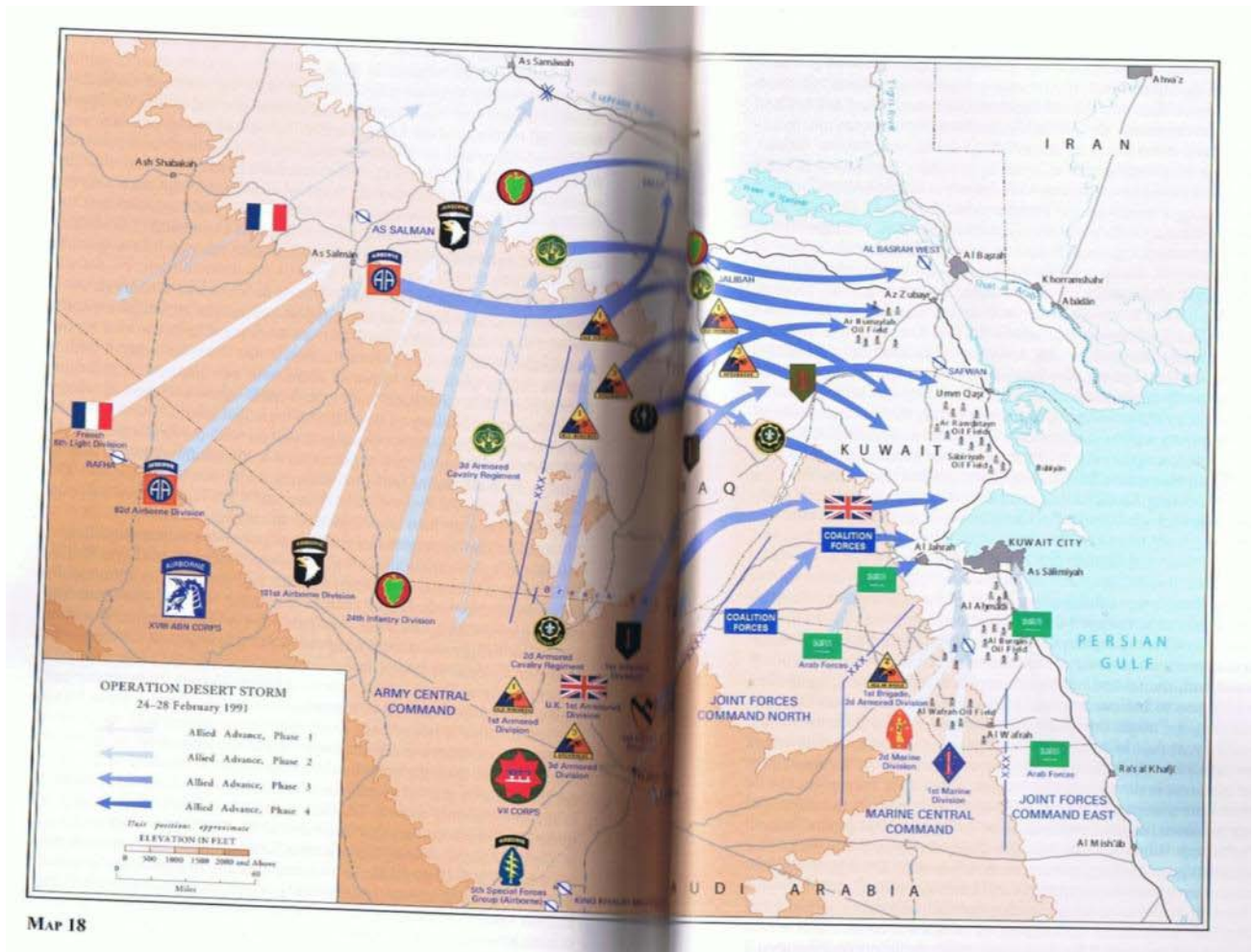

Source: John S. Brown, “The Maturation of Operational Art: Operations Desert Shield and Desert Storm” in *Historical Perspectives of the Operational Art*, ed. Michael D. Krause and R. Cody Phillips (Washington, D.C.: Center of Military History, 2007), 450-451.

## Appendix I--Task Organization for Heavy Brigade Combat Team

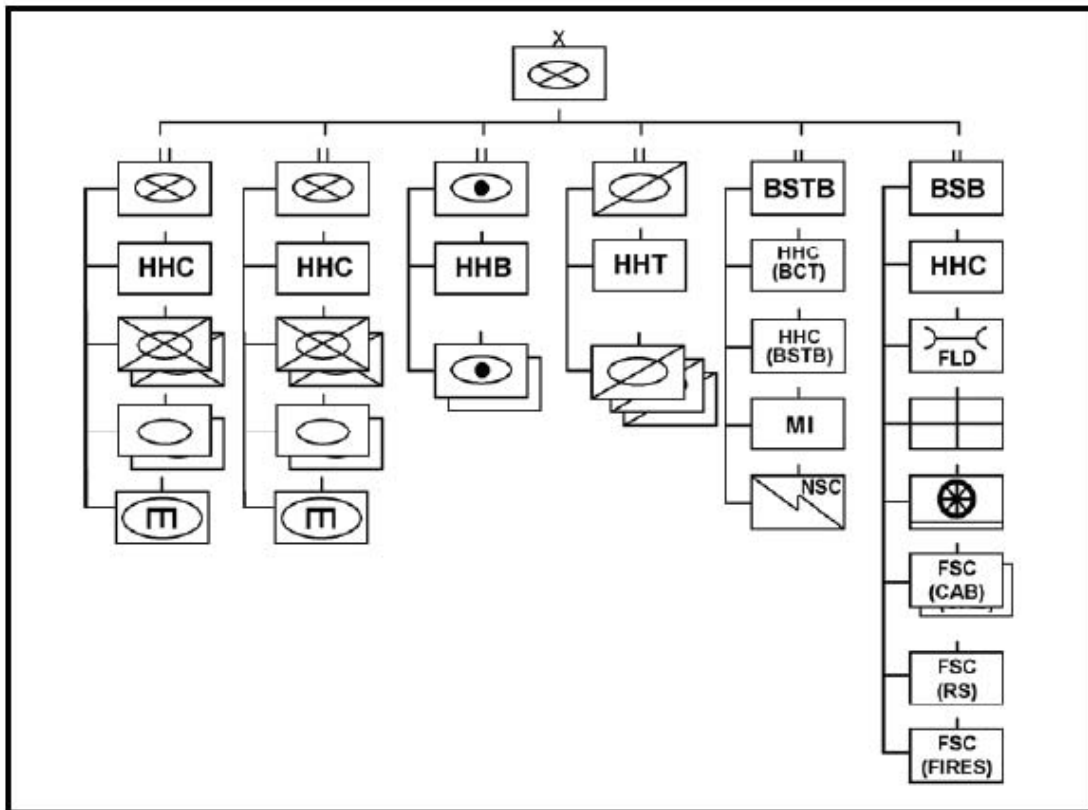

Source: Field Manual 3-90.6: *The Brigade Combat Team* (Washington, D.C.: U.S. Government Printing Press, 2006), A-1.

## Appendix J– Operation GREEN DAWN Logistics Results

### POL CONSUMPTION DATA

*Class III / Bulk POL Consumption by unit per day*

	Day 1	Day 2	Day 3	Total
<b>1st HBCT</b>	83,808	83,808	83,808	251,424
<b>2nd HBCT</b>	83,808	83,808	83,808	251,424
<b>3rd HBCT</b>	83,808	83,808	83,808	251,424
<b>4th IBCT</b>	21,661	21,661	21,661	64,983
<b>AVN BDE</b>	106,809	106,809	106,809	320,427
<b>Fires BDE</b>	43,962	43,962	43,962	131,886
<b>DIV Total</b>	423,856	423,856	423,856	1,271,568

*Sustainment CMD:*

tot req =  
/ 5,000 Gallons = Fuel  
Tankers Req.:

423,856	423,856	432,856	1,271,568
95	95	95	285

X # / company;

# of companies req.:

There are 60 in a POL Support Company			
1.6	1.6	1.6	2 per day

*HBCT*

*Brigade Support BN:*

HBCT tot req =  
/ 2,500 gallons = Fuel  
Tankers req.:

83,808	83,808	83,808	251,424
35	35	35	105

# fuelers / FSC

# fuelers / Distro Co

12 M978 per company x 4 companies = 48

There are 30 M978 per company

78 total in  
BSB

Delta:

extra 43	extra 8	short 27*	Only short 27*
----------	---------	--------------	-------------------

\*However would probably receive fuel push on day 2 and therefore no shortage identified after that.

Assumption: O/R rate of fuel tankers is 100%

Assumption: 5K fuel tankers filled to 4.5; 2.5K HEMTT tankers at 2.4 K

Assumption: Need to maneuver with fuel in tankers not in bags



## AMMUNITION CONSUMPTION DATA

*Class V / STONS ammunition consumption by unit per day*

	Day 1	Day 2	Day 3	Total
<b>1st HBCT</b>	61.7	61.7	61.7	185.1
<b>2nd HBCT</b>	61.7	61.7	61.7	185.1
<b>3rd HBCT</b>	61.7	61.7	61.7	185.1
<b>4th IBCT</b>	6.9	6.9	6.9	20.7
<b>AVN BDE</b>	5.5	5.5	5.5	16.5
<b>Fires BDE</b>	1175.5	1175.5	1175.5	3526.5
<b>DIV Total</b>	1373	1373	1373	4119

*HBCT*

*Brigade Support BN:*

HBCT tot req =	62	62	62	186
capability of 1 x FSC	57 STONS of class V per day by 1 FSC			
capability of Distro Co	204 STONS of class V + 4 containers per day			
with 10 % loss per day than capability is	FSC = 51 DISTRO = 183	FSC = 46 DISTRO = 165	FSC = 41 DISTRO = 148	Or 164 STONS in all 4 x FSCs
Delta from FSC:	Short 5 STONS	Short 16 STONS	Short 21 STONS	
Delta from BSB:	No delta as the Distribution company is adequate to support (312 STONS capable)			

Planning Factor: Support systems in the attack are lost at 10%. Assumption: OR of trucks starts at 100%, a 10 % loss in trucks equates to an equal loss in capability.

Assumption: the trucks are hauling ammunition and not other items.

## MAINTENANCE DATA

### Planning Factors:

Loss rate of M1 in the attack is 18%

Loss rate of M2/3 in the attack is

22%

Of those lost, 20% are non-reparable

Of the 80% reparable, 60% are in field and 40% are in sustainment maintenance

Probably about a 1 day turnaround on equipment in field maintenance

Equipment in sustainment maintenance is turned in to the supply system and it takes much longer to repair.

**Assumption:** no Class VII replacements in this short period of time

*Steps for determining a HBCT's M1 Abrams tanks losses:*

Step	Task	Data	Remarks
1	Determine tanks Assigned	2 x CAB @ 30 M1s = 60	Total: 60
2	Determine reparable distribution	Field Maint: 60% Sust. Maint: 40%	Loss rate day 1 = 18% Subsequent days = 18% reparable = 80%
3	Calculate Losses for day 1	60 x 18% = 11 tanks lost	49 remaining end of day 1 (OR = 82%)
4	Determine reparable distribution	11 tanks lost x 80% reparable = 9 tanks reparable	Repairable Distribution: Field = 5 ; Sustainment = 4
5	Calculate Losses for day 2	49 x 18% = 9 tanks lost	40 remaining end of day 2 (OR = 66%)
6	Determine reparable distribution	9 tanks lost x 80% reparable = 7 Tanks reparable	Repairable Distribution: Field = 5 +4 ; Sustainment = 4 + 3
7	Add back equipment returned from maintenance	40 tanks left + 5 repaired = 45 at end of day 2	45 at start of day 3 (OR = 75%)
8	Calculate Losses for day 3	45 x 18% = 8 tanks lost	37 remaining at end of day (OR = 62%)
9	Determine reparable distribution	8 tanks lost x 80% reparable = 6 tanks reparable	Repairable Distribution: Field = 4 + 4 ; Sustainment = 4 + 3 + 2
10	Add back equipment returned from maintenance	37 tanks + 4 repaired from Field M. = 41 at end of day 3	<b>41 tanks remaining at end of day (OR = 68%)</b>

## MEDICAL DATA

**Assumption:** no personnel replacements are available in theater

Step	Action	Note
1	Determine casualty rates	Type of operation: offense; Breach Rate: .007; Decisive Operation Day 1 rate: .04 Succeeding Days Rate: .02
2	Calculate Day 1 casualty estimate	$20,000 \times .007 = 140$ casualties; Decisive operation day 1 estimate = $(20,000 - 140) \times .04 = 795$ casualties
3	Calculate Day 2 casualty estimate	$(20,000 - 140 - 795) \times .02 = 381$ casualties
4	Calculate Day 3 casualty estimate	$(20,000 - 140 - 795 - 381) \times .02 = 374$ casualties

Note: this doesn't factor in return to duty personnel

## BIBLIOGRAPHY

- 1st Infantry Division staff. *Lessons Learned during Operation Desert Storm*. After Action Review, APO NY: 1st Infantry Division, 1991.
- 1st Infantry Division, G3. *G3 Report of Operations, 1- 31 July*. AAR, 1st Infantry Division, G3, 1944.
- 22nd Support Command. *22nd Support Command, After Action Report*. After Action Report, Executive Summary, Vol I., Dhahran: 22nd Support Command, 1991.
- 3rd AD association. *3rd AD, Order of Battle, WWII*.  
[http://www.3ad.org/wwii/wwii\\_order\\_of\\_battle.htm](http://www.3ad.org/wwii/wwii_order_of_battle.htm) (accessed November 24, 2009).
- After Action Report, G4 Section (JUN 44-DEC 44 & DEC 45)*. AAR, G4, 1st Infantry Division, G4 Section, 1945.
- Andrews, LTC John. Interview by MAJ Thomas Popa. *Interview with LTC John Andrews* (July 24, 1991).
- Blumenson, Martin. *Breakout and Pursuit*. Washington, DC: Center of Military History, 1984.
- Blundell, James D., COL (ret.). *Operations Desert Shield and Desert Storm: The Logistics Perspective*. Special Report, Washington, D.C.: Association of the United States Army, 1991.
- Boehler, MAJ Dennis T. *159th Support Group: Desert Shield & Desert Storm*. Historical Report, APO New York: 159th Support Group Historian, 1991.
- Bourque, Stephen A. *Jayhawk! The VII Corps in the Persian Gulf War*. Washington, D.C.: Department of the Army, 2002.
- Bourque, Stephen A., and John W. III Burdan. *The Road to Safwan: the 1st Squadron, 4th Cavalry in the 1991 Persian Gulf War*. Denton: University of North Texas Press, 2007.
- Brown, John S. "The Maturation of Operational Art: Operations Desert Shield and Desert Storm." In *Historical Perspectives on the Operational Art*, by Michael D. Krause and Cody R. Phillips, 439-481. Washington, D.C.: Center of Military History, 2007.
- Buffington, LTC Edwin L., interview by LTC William H. Talyor. *U.S.A. Center for Military History* (December 13, 1991).
- Burgin, Leo B. MAJ. *Headquarters, First Medical Battalion*. Historical Records and History of Organization, Marigny: 1st Medical Battalion, 1944.
- Carafano, James Jay. *After D-Day: Operation Cobra and the Normandy Breakout*. Boulder: Lynne Rienner Publishers, Inc, 2000.
- CASCOM. *Logistics Force Structure Book*. Ft. Lee: U.S. Army Combined Arms Support Command, 2010.
- \_\_\_\_\_. *Modular Force Logistics Concept, Version 6*. Ft. Lee: U.S. Government Printing Press, 2006.
- CGSC. *Combat Service Support Battle Book*. Ft. Leavenworth: U.S. Army Command and General Staff College, 2007.
- \_\_\_\_\_. *Sustainment in the Theater of War*. Ft. Leavenworth: U.S. Army Command and General Staff College, 2007.

- Citino, Robert M. *Blitzkrieg to Desert Storm: The Evolution of Operational Warfare*. Lawrence: University Press of Kansas, 2004.
- Cordesman, Anthony H., and Martin Kleiber. *Iran's Military Forces and Warfighting Capabilities*. Westport: Praeger Security International, 2007.
- Corum, James S. "Forbes." *Supply the Big Red One - France, July 1944*. June 5, 2008. <http://www.forbes.com/2008/06/05/logistics-wwii-usarmy-tech-logistics08-cx-jc-0605normandy> (accessed August 10, 2009).
- Department of Defense. *Joint Publication 1-02: Department of Defense Dictionary of Military and Associated Terms*. Washington, D.C.: U.S. Government Printing Press, 2007.
- Department of the Army. *Field Manual 100-10: Combat Service Support*. Washington, D.C.: U.S. Government Printing Press, 1995.
- \_\_\_\_\_. *Field Manual 3-0: Operations*. Washington, D.C.: Department of the Army, 2008.
- \_\_\_\_\_. *Field Manual 3-90.6: The Brigade Combat Team*. Washington, D.C.: U.S. Government Printing Press, 2006.
- \_\_\_\_\_. *Field Manual 4-0: Sustainment*. Washington, D.C.: US Government Printing Press, 2009.
- \_\_\_\_\_. *Field Manual 4-93.4: Theater Support Command*. Washington, D.C.: U.S. Government Printing Press, 2003.
- \_\_\_\_\_. *Field Manual 54-30: Corps Support Groups*. Washington, D.C.: U.S. Government Printing Press, 1993.
- \_\_\_\_\_. *Field Manual 63-2: Division Support Command Armored, Infantry, & Mechanized Infantry Divisions*. Washington, D.C.: US Government Printing Press, 1991.
- \_\_\_\_\_. *Field Manual 63-20: Forward Support Battalion*. Washington, D.C.: US Government Printing Press, 1990.
- \_\_\_\_\_. *Field Manual 63-21: Main Support Battalion*. Washington, D.C.: U.S. Government Printing Press, 1990.
- \_\_\_\_\_. *Field Manual 63-3: Corps Support Command*. Washington, D.C.: U.S. Government Printing Press, 1993.
- \_\_\_\_\_. *Field Manual 63-4: Combat Service Support Operations - Theater Army Area Command*. Washington, D.C.: U.S. Government Printing Press, 1984.
- \_\_\_\_\_. *Field Manual 71-100: Division Operations*. Washington, D.C.: U.S. Government Printing Press, 1996.
- \_\_\_\_\_. *Field Manual Interim 4-93.2: The Sustainment Brigade*. Washington, D.C.: U.S. Government Printing Press, 2009.
- Dinackus, Thomas, D. *Operation Desert Storm: Allied Ground Forces, Order of Battle*. Alexandria: PSI Research, 1995.
- Dunnigan, James F., and Austin Bay. *From Shield to Storm: High Tech Weapons, Military Strategy, and Coalition Warfare in the Persian Gulf*. New York: William Morrow and Company, Inc., 1992.
- Eymer, Clarence. *1st Infantry Division, Administrative Order #1*. Admin Order, France: 1st ID, G4, 1944.

- Greenfield, Kent Roberts. *The Army Ground Forces: The Organization of Ground Combat Troops*. Washington, D.C.: Historical Division, US Army; US Government Printing Press, 1947.
- Huntoon, Raymond G. CPT. *701st Ordnance Light Maintenance Company*. After Action Report, France: 1st Infantry Division, 1944.
- Huston, James A. *The Sinews of War: Army Logistics 1775-1953*. Washington, D.C.: Office of the Chief of Military History, 1966.
- Kehm, H.D., LTC. "Artillery Ammunition Supply." *The Field Artillery Journal*, VOL 32, No 4, 1942: 268-273.
- Keough, LTC Rich Tate and LTC Elizabeth Delbridge, interview by LTC Mary Morehouse-Crane. *Key Leader Interview, 13th ESC Support Operations Center, Iraq* (September 02, 2009).
- Kimball, LTC Charlotte, E. "A small part of the whole...a large part of me." In *Personal Perspectives on the Gulf War*, by The Institute of Land Warfare, 56-59. Arlington: Association of the United States Army, 1993.
- King, Benjamin J., Richard C. Biggs, and Eric R. Criner. *Spearhead of Logistics: A History of the United States Army Transportation Corps*. Ft. Eustis: US Army Transportation Center, 1994.
- King, John J., CPT. *1st Quartermaster Company, Report After Action*. AAR, Coutance, France: 1st Quartermaster Company, 1944.
- Knickerbocker, H.R. et al. *Danger Forward: The Story of the First Division in World War II*. Atlanta: Albert Love Enterprises, 1947.
- Leigh, LTC Randolph. *48 Million Tons to Eisenhower: The Role of the SOS in the Defeat of Germany*. Washington, D.C.: The Infantry Journal, 1945.
- Lovins, Amory B. "DOD's Energy Challenge as Strategic Opportunity." *Joint Force Quarterly*, 2010: 33-42.
- Mansoor, Peter R. *The GI Offensive in Europe: The Triumph of American Infantry Divisions, 1941-1945*. Lawrence: University of Kansas Press, 1999.
- Marlin, LTC David W. *History of the 4th Battalion, 37th Armor Regiment in Operation Desert Shield/Desert Storm*. Individual Study Project, Saudi Arabia: 4-37 AR, 1992.
- McGee, Joseph B. Major. "Combat Observations of an Infantry Division G4." *Military Review*, 1946: 34-38.
- Millet, John D. *The Organization and Role of the Army Service Forces*. Washington, D.C.: Center of Military History, 1985.
- Rhame, MG Thomas, interview by MAJ Thomas Popa. *Interview with MG Thomas Rhame* (July 26, 1991).
- Richardson, Eudora Ramsay, and Allan Sherman. *Fuels and Lubricants, VOL IV; Quartermaster Supply in the ETO*. Camp Lee, VA: The Quartermaster School, 1948.
- Ross, William F., and Charles F. Romanus. *The Quartermaster Corps: Operations in the War against Germany*. Washington, D.C.: Office of the Chief of Military History, Department of the Army, 1965.

- Ruppenthal, Roland G. *Logistical Support of the Armies, Volume I*. Washington, D.C.: U.S. Government Printing Press, 2000.
- Sayen, John. *US Army Infantry Divisions, 1944-45*. Oxford: Osprey Publishing, 2007.
- Swain, Richard M. *"Lucky War": Third Army in Desert Storm*. Fort Leavenworth: U.S. Army Command and General Staff College Press, 1994.
- The General Board, ETO. *Supply Functions of Corps, Study Number 28*. The General Board, ETO, United States Forces, European Theater, 1945.
- Van Creveld, Martin. *Supplying War: Logistics from Wallenstein to Patton*. Cambridge: Cambridge University Press, 1977.
- VII Corps. *Combat SITREP #36-43*. Daily Situation Report, Saudia Arabia: VII Corps, 1991.
- "VII Corps in Operation Cobra (1)." *LTG Lawton Collins Papers, Box 5*. Eisenhower Library records, July 1944.
- Waddell, Steve R. *US Army Logistics: The Normandy Campaign*. Westport: Greenwood Press, 1994.
- War Department. *Field Manual 100-5: Operations*. Washington, D.C.: War Department, 1944.
- \_\_\_\_\_. *Field Manual 101-10: Staff Officers' Field Manual Organization, Technical, and Logistical Data*. Washington, D.C.: War Department, 1944.
- \_\_\_\_\_. *Field Manual 101-5: Staff Officers' Field Manual*. Washington, D.C.: War Department, 1940.
- \_\_\_\_\_. *Field Manual 17-50: Field Service Regulations: Logistics*. Washington, D.C.: War Department, 1942.
- \_\_\_\_\_. *Field Manual 17-57: Supply Battalion, Armored Division*. Washington, D.C.: War Department, 1942.
- \_\_\_\_\_. *Field Manual 7-30: Infantry Supply and Evacuation*. Washington, D.C.: War Department, 1944.
- \_\_\_\_\_. *Field Manual 8-10: Medical Service of Field Units*. Washington, D.C.: War Department, 1942.
- Weigley, Russell F. "Normandy to Falaise: A Critique of Allied Operational Planning in 1944." In *Historical Perspectives of the Operational Art*, by Michael D. Krause and R. Cody Phillips, 393-413. Washington, D.C.: Center of Military History, 2007.
- Wheeler, James Scott. *The Big Red One: America's Legendary 1st Infantry Division from World War I to Desert Storm*. Lawrence: University of Kansas Press, 2007.
- Zaloga, Steven J. *US Armored Divisions: The European Theater of Operations, 1944-45*. Oxford: Osprey Publishing, 2004.