



**PERFORMANCE OF MILITARY CARGO AIRCRAFT
USING REQUIRED NAVIGATION PERFORMANCE DEPARTURES**

GRADUATE RESEARCH PROJECT

Tracy N. Hunter, Major, USAF

AFIT-IOA-ENS-10-07

**DEPARTMENT OF THE AIR FORCE
AIR UNIVERSITY**

AIR FORCE INSTITUTE OF TECHNOLOGY

Wright-Patterson Air Force Base, Ohio

APPROVED FOR PUBLIC RELEASE; DISTRIBUTION UNLIMITED.

The views expressed in this thesis are those of the author and do not reflect the official policy or position of the United States Air Force, Department of Defense, or the United States Government.

AFIT-IOA-ENS-10-07

**PERFORMANCE OF MILITARY CARGO AIRCRAFT
USING REQUIRED NAVIGATION PERFORMANCE DEPARTURES**

GRADUATE RESEARCH PROJECT

Presented to the Faculty

Department of Operational Sciences

Graduate School of Engineering and Management

Air Force Institute of Technology

Air University

Air Education and Training Command

In Partial Fulfillment of the Requirements for the
Degree of Master of Science in Operations Analysis

Tracy N. Hunter

Major, USAF

June 2010

APPROVED FOR PUBLIC RELEASE; DISTRIBUTION UNLIMITED.

AFIT-IOA-ENS-10-07

**PERFORMANCE OF MILITARY CARGO AIRCRAFT
USING REQUIRED NAVIGATION PERFORMANCE DEPARTURES**

Tracy N. Hunter
Major, USAF

Approved:

 //SIGNED//
Dr. Raymond Hill, AFIT (Advisor)

 11 JUNE 2010
date

Abstract

Maximum takeoff weight for cargo aircraft is affected by many factors including the aircraft's ability to safely climb out to altitude. When there are obstacles in the departure path, the total weight of the aircraft may have to be reduced to ensure the aircraft will achieve the appropriate climb rate to clear the obstacles. During times of limited visibility, aircrews traditionally rely on predetermined departure paths limited by the aircraft navigation capability and the ground based navigation aids. A Required Navigation Performance (RNP) departure with accuracy down to 0.3 mile could allow the aircraft to safely navigate around obstacles with better precision, allowing a greater takeoff weight.

This study compared current instrument departure procedures with predicted RNP 0.3 departures by computing the maximum allowable weight limit for the C-5 aircraft under a range of operating temperatures at three separate locations. The results showed that an increased precision of the RNP 0.3 departures had an operational advantage by allowing an increased cargo, passenger, or fuel load. The amount of weight increase was dependent upon a variety of factors, to include airframe type and location. To receive certification from the FAA to fly RNP 0.3 procedures, specific requirements such as training and equipment are necessary. Current configurations of the C-5 aircraft do not support RNP 0.3 procedures.

*To my children, who will be the
true beneficiaries of the
next generation of air transportation.*

Acknowledgments

I would like to express my sincere appreciation to my research advisor, Dr. Raymond Hill, for his guidance and patience throughout the course of this research effort.

I would also like to thank my sponsor, Ms. Tammy Place, from the Air Force Flight Standards Agency for both the support and latitude provided to me in this endeavor.

I am also indebted to the many subject matter experts who spent their valuable time explaining the processes used in developing aircraft departure procedures and weight limitations for the C-5 aircraft. Special thanks go to Mr. Rick Packard, MSgt Jeremy Turner, Mr. Kirk Burmeister and Mr. Mike Kushner for the countless hours they dedicated to guide me through this process and for always being available to answer questions. Additionally, I would like to thank Mr. Brian Pierce and Mr. Jeff Stevens for providing the initial focus for this research topic.

Most importantly, this project would not have been possible without the grace of God and the unwavering support of my husband. His strength serves as a rock for me in every aspect of my life. Words cannot express the gratitude I have for him and all he does.

Tracy N. Hunter, Major, USAF
AFIT/ENS

Table of Contents

	Page
Abstract	iv
Dedication	v
Acknowledgments.....	vi
List of Figures.....	ix
List of Tables	x
I. Introduction	1
Background.....	3
Research Focus	5
Research Objectives/Questions/Hypotheses	5
Methodology.....	6
Assumptions/Limitations	6
Implications.....	7
II. Literature Review.....	9
Aircraft Navigation	9
Traditional Aircraft Navigation	9
Performance-Based Navigation (PBN).....	10
RNP vs RNAV	10
RNP Containment	11
RNP Monitoring.....	13
History of RNP	14
Collaboration.....	14
Applications	15
RNP Users.....	15
Benefits	16
Issues.....	18
How to achieve RNP.....	19
Takeoff Weight Limitations.....	20
III. Methodology	23
Takeoff Weight Calculation.....	23
Sources of Constraints	23
Obstacle Data.....	24

IV. Results and Analysis	28
Results.....	28
Interpreting Obtained Results	30
V. Discussion.....	31
Relevance of this Study	31
Military Application.....	32
Additional Area of Study.....	32
Conclusion	33
Appendix A. Published RNP 0.3 Departure Procedure Canberra, Australia.....	34
Appendix B. Data Results for Analysis	35
Appendix C. Abbreviations	36
Appendix D. Blue Dart	37
Bibliography	40
Vita	43

List of Figures

	Page
Figure 1. Accident Percentage as a Phase of Flight	2
Figure 2. Lateral Navigation Error	4
Figure 3. Obstacle Avoidance Area with Splay for Obstacle Avoidance	4
Figure 4. Conventional Navigation Compared to RNAV	9
Figure 5. Traditional Navigation versus RNAV and RNP	10
Figure 6. RNP Containment	11
Figure 7. Tunnel in the Sky	12
Figure 8. RNP Containment Zones	12
Figure 9. Alerting System when RNP is Exceeded	13
Figure 10. Atlanta Airport RNAV Radar Tracks	16
Figure 11. RNP versus Non-RNP Flight Paths	17
Figure 12. RNP Segment Width	19
Figure 13. Controlling Obstacle Example	21
Figure 14. Factors Impacting Maximum Gross Takeoff Weight	22
Figure 15. Departure from Jackson Hole in Instrument Design Procedure	25
Figure 16. Comparing Takeoff Weights for C-5 Aircraft at Nellis AFB, NV	28
Figure 17. Comparing Takeoff Weights for C-5 Aircraft at Jackson Hole, WY	29
Figure 18. Comparing Takeoff Weights for C-5 Aircraft at Canberra, Australia	29
Figure 19. Percent Increase in Gross Takeoff Weight for C-5 Aircraft	30

List of Tables

	Page
Table 1. RNP Operations and Required RNP Values	13
Table 2. Variable Setting Used in Calculations for Maximum Gross Takeoff Weight .	26
Table 3. Average Weight Increase by Using RNP 0.3 Departure.....	30

**PERFORMANCE OF MILITARY CARGO AIRCRAFT
USING REQUIRED NAVIGATION PERFORMANCE DEPARTURES**

I. Introduction

“Aviation in itself is not inherently dangerous. But...it is terribly unforgiving of any carelessness, incapacity or neglect.”

- Captain A. G. Lamplugh

Navigating an aircraft out of an airfield during limited visibility and unfamiliar terrain can be an enormous challenge for even the most experienced pilots. A majority of aircraft accidents occur during the takeoff and final approach phases of flight according to International Civil Aviation Organization (ICAO) statistics spanning over 30 years as illustrated in Figure 1 (Cassell, 1995:3). Inability to clear obstacles during these phases is a major contributor of those accidents. Tragically, a leading cause of aviation accidents is known as Controlled Flight into Terrain (CFIT) which occurs when a properly functioning aircraft with trained crew crashes into an obstacle (Andersen, 2002:40). A military example of CFIT occurred in 1996 at Jackson Hole, WY when a C-130 aircraft crashed into the mountains during a nighttime departure. The investigation revealed that the accident was due to difficult terrain encountered upon takeoff rather than a blatant error such as pilot inexperience, lack of qualification or aircraft failure (FSF, 2000:3).

The accident could have been avoided if the crew had been aware of their precise location in relation to the mountains and planned for an instrument departure.

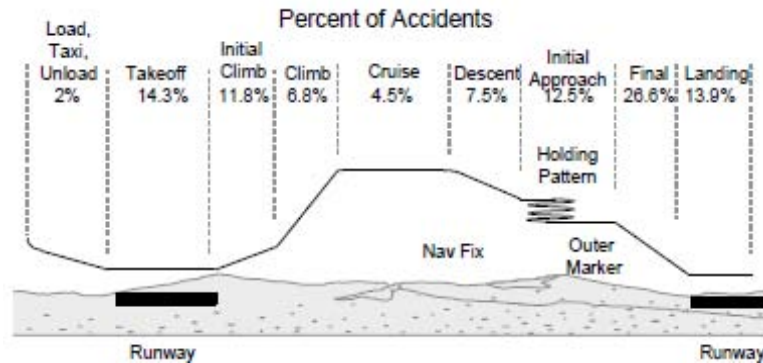

Figure 1. Accident Percentage as a Phase of Flight (Cassell, 1995:3)

The Federal Aviation Administration (FAA) is now placing more emphasis on Performance Based Navigation (PBN) as a way to increase safety and enhance operations. The standards for PBN are being developed with close collaboration from ICAO and the Department of Defense (DoD) (DoT, 2006:1). These standards are being implemented within the FAA's overarching modernization plan for the Next Generation Air Transportation System (NextGen) (DoT, 2010:6). Required Navigation Performance (RNP) operations are essential in the transition to PBN. RNP enables aircraft to fly on any desired flight path within the limits of the precision navigation aid coverage and the aircraft on-board performance monitoring and alerting capability (ICAO 9613, 2008:I-(xx)). The value associated with the RNP operation specifies the allowable error in navigation. As the RNP value decreases, the allowable navigational error also decreases while the required level of precision increases. Recent technological advancements enabling more precise RNP provide pilots better accuracy in navigation, resulting in a better perspective and confidence of their location. Although there are numerous benefits

to RNP operations such as increased efficiency, this study investigates how one specific procedure, RNP 0.3 departures, can increase precision allowing safe navigation around obstacles rather than having to fly above them. This can facilitate greater mission performance for military cargo aircraft by allowing an increase in the maximum takeoff weight.

Background

Military deployments require large amounts of equipment and personnel to be transported overseas. Cargo aircraft are designed for rapid movement of assets, but are limited in the amount of cargo that can be transported. During times of rapid deployments, operations could be enhanced if more flexibility existed in the amount of cargo that could be transported by air. Unfortunately, there are a number of constraints that prevent the increase of cargo loads such as the number of aircraft available, airframe limitations and runway conditions. In order to overcome some of these constraints, planners have developed innovative ways to increase the allowable payload weight of an aircraft, such as trading off fuel for payload at takeoff and then refueling shortly after reaching altitude (Toydas, 2010:2). Developing additional procedures to increase payload in terms of cargo, fuel and passengers, can have an impact on military operations by allowing more equipment to get to the fight faster.

One potential technique that would allow an increase in maximum takeoff weight of an aircraft is the modification of the departure flight path when there are obstacles present. Without precision navigation, an aircraft would have to increase the rate of climb to clear the obstacles in the departure path. This is not only less efficient by burning more fuel, but the overall gross takeoff weight has to be decreased to allow for a

higher climb rate. Navigating around the obstacles is not always an option because the aircraft's lateral navigation error, shown in Figure 2, prevents the pilot from recognizing the aircraft's actual location.

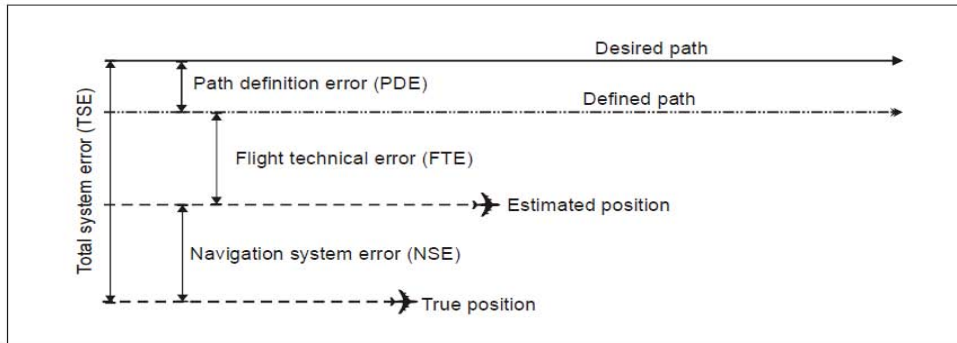

Figure 2. Lateral Navigation Errors (ICAO 9613, 2008:II-A-2-2)

On takeoff, the aircraft must fly above the height of any obstacle contained in the buffer caused by lateral navigation errors. This buffer is directly on the aircraft's intended path. This buffer is increasingly wider because wind effects cause the aircraft to drift from the end of the runway as shown in Figure 3.

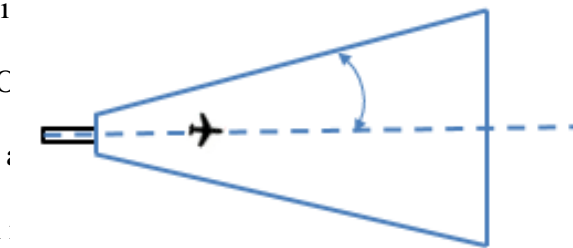

Figure 3. Obstacle Avoidance Area with Splay

If, however, the aircrew had the proper training and equipment to identify the aircraft's precise location as well as an on-board monitoring system to verify the integrity of the

information, the lateral navigation error could be reduced. In this case, navigating around the obstacle could be a viable option and would allow a greater gross takeoff weight.

Research Focus

The purpose of this research was to explore how developing technologies, policies and procedures can impact the future of military operations. The focus was to compare current aircraft departures with RNP 0.3 departures by calculating the maximum gross takeoff weight of a C-5 aircraft over a range of temperatures.

Research Objectives, Research Questions and Hypotheses

The overall objective of this research was to determine if there are operational advantages of increased navigation precision on departures where obstructions present a problem. The questions addressed with this research were:

1. At specific airfields where obstacles prevent an optimal climb rate, does an RNP 0.3 departure change the controlling obstacle along the departure path? If so, does this allow a decreased climb gradient?
2. If there is a change in the controlling obstacle for the departure path, does this impact the maximum gross takeoff weight allowed for the C-5 aircraft at these locations? What is the impact?
3. In general, what is required to achieve an RNP 0.3 departure?

It was hypothesized that for airfields with obstacles along the departure path, flying an RNP 0.3 departure will change the controlling obstacle and will allow an increase in the maximum allowable gross takeoff weight for the C-5 aircraft.

Methodology

Three separate airfield locations were chosen to perform the comparison. The first two locations, Jackson Hole, WY and Nellis AFB, NV were selected because of existing terrain barriers along the departure path. The third location, Canberra, Australia was selected because airlines are already flying published RNP 0.3 departure procedures at that airfield. The published procedure used for this study is referenced in Appendix A (AirServices Australia, 2009). The RNP value of 0.3 was selected because aircraft will typically need to be certified to an RNP value of 0.3 or better (lower) when it is being used for approach operations (Paylor, 2006:57). Similarly, avoiding obstacles on departure would require a comparable amount of precision as an approach. Also, current aircraft, Global Positioning System (GPS), and infrastructure technology support this RNP value. Values below 0.3 become more difficult and expensive (Roberts, 2005:45).

The C-5 aircraft was selected for this study because it is the largest cargo aircraft in the USAF inventory and one of the largest aircraft in the world (DoAF, 2009). It was designed as a long-range aircraft capable of transporting outsize cargo and is ideal in demonstrating whether such a large aircraft could navigate between obstacles during departures (GAO, 1984:1).

For each of the runways selected, the maximum gross takeoff weight was calculated for a current instrument departure and then for an RNP 0.3 departure.

Assumptions/Limitations

The major assumption that was made for this project was concerning the RNP departure criteria. It was assumed that the RNP 0.3 departure standards established by the Civil Aviation Safety Authority in Australia will be the same criteria established by

the FAA in the United States in the future. Since there is world-wide collaboration on the acceptable standards for aviation through ICAO, it is highly unlikely that the standards will be substantially different for the United States. If, however, there are major variations in the criteria, the evaluations made in this study may not be valid for CONUS-based departures.

Limitations of the study stem from the data's dependency on multiple variables. The results presented in this report are dependent upon the specific airfield, obstacle location, airframe, and aircrew. There were also many variables such as wind direction and velocity that were held constant that may have an effect on the results if they were varied. Sensitivity analysis was not performed during this research.

Furthermore, the analysis was conducted to demonstrate how future avionics upgrades could be beneficial for cargo aircraft. At the time of this project, the C-5 aircraft did not have the avionics to support RNP 0.3 operations.

Implications

The benefits gained from the various aspects of RNP encompass all phases of flight from departure, enroute, and terminal approach operations and go well beyond the scope of this research. Modernizing aircraft avionics will not only enhance the safety, but also have a huge impact on the efficiency of operations. Although current technology can support RNP operations, the cost of implementation needs to be evaluated against the benefits for aircraft nearing the end of its service life. Careful consideration needs to be made for the inclusion of RNP enabling avionics in the development of new aircraft weapon systems.

This study was intended to complement other research conducted on the benefits of RNP both in the civil community and for the DoD. It was not intended to be considered in isolation or become the sole basis of any decisions concerning the future upgrades of aircraft avionics.

II. Literature Review

It is better to be uncertain of where you are and know it
then to be certain of where you are not.”

– Author Unknown (ATW, 2009:35)

Aircraft Navigation

Traditional Aircraft Navigation

The infrastructure currently in place for traditional aircraft navigation in the US was implemented in the 1940s (ATW, 2009:35). Using this equipment, an aircraft’s vertical position is determined by an altimeter while the lateral position is found from ground-based radio navigation aids (NAVAID) (Andersen, 2002:40). This conventional navigation method has many shortfalls to include inaccuracy and the potential single-point failure of a NAVAID (Carey, 2006:A15). Efficiencies are lost because the aircraft must fly from one NAVAID to the next rather than a direct path from departure to destination as shown in Figure 4.

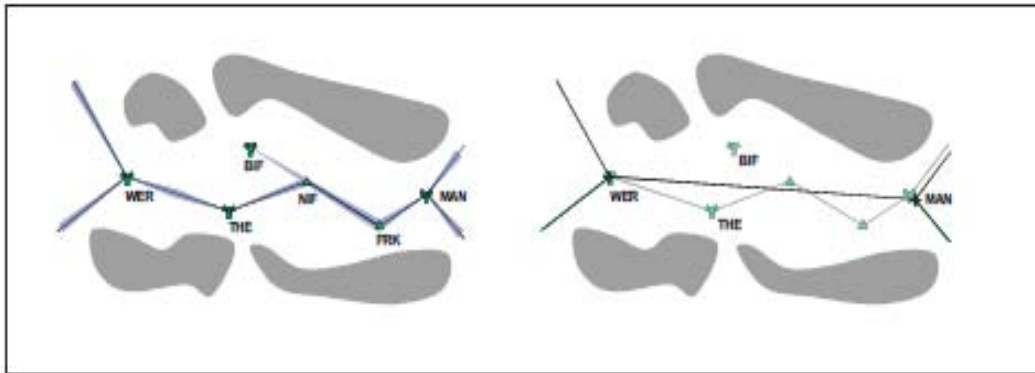

Figure 4. Conventional Navigation Compared to RNAV (ICAO 9613, 2008:I-A1-2)

Performance Based Navigation (PBN)

The international aviation community is making an immense movement toward PBN. PBN is an overarching aircraft navigation concept that is characterized by a reliance on aircraft performance capabilities as opposed to traditional ground-based navigation aids. PBN procedures have many applications and have already saved fuel and reduced emissions both within the US and internationally (DoT, 2010:5).

RNP vs RNAV

PBN is enabled by two key concepts: area navigation (RNAV) and RNP. RNAV allows aircraft to fly a more direct route between departure and destination because the aircraft has the capability to navigate without relying on specific location of ground navigation aids as shown in Figure 4 (ICAO 9613, 2008:I-A-3-5). RNP is more precise than RNAV (Hutchinson, 2007:22). RNP is defined as an RNAV operation with the additional requirement for monitoring, alerting, and containment (Paylor, 2006:58). The difference between traditional navigation, RNAV and RNP are illustrated in Figure 5.

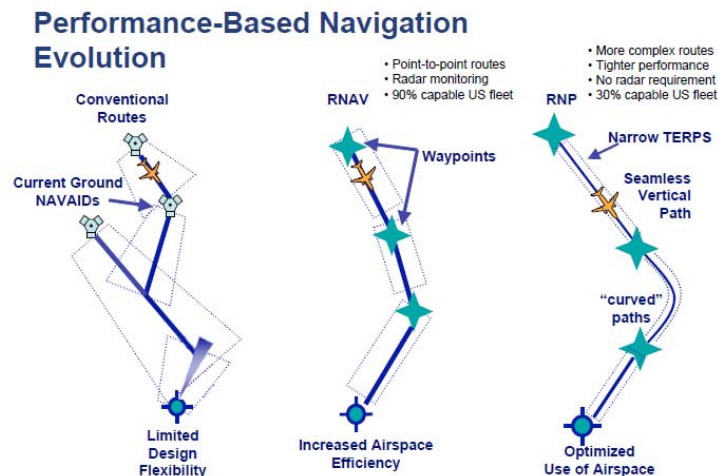

Figure 5. Traditional Navigation versus RNAV and RNP (Tarbert, 2006:4)

For procedures designated as RNP operations, only certified pilots flying certified aircraft may perform the RNP procedure.

RNP Containment

The RNP value defines the lateral airspace required for the specific RNP procedure. The number associated with RNP is the distance in nautical miles to the right and left of centerline of the intended path where the aircraft must remain 95% of the time to successfully perform the operation (George, 2009:59). RNP flight paths are created by carving out a distance two times the RNP value on either side of the centerline of the intended path. In Figure 6, the aircraft's total system error (TSE) budget must be small enough for the aircraft to remain in a width of $4 \times \text{RNP}$ with 95% accuracy (George, 2009:59). This level of accuracy means that the average of the "fleet" over time won't go outside the limits more than 5% of the time, not that an individual aircraft is allowed to exceed the limits 5% of the time. (Roberts, 2008:43)

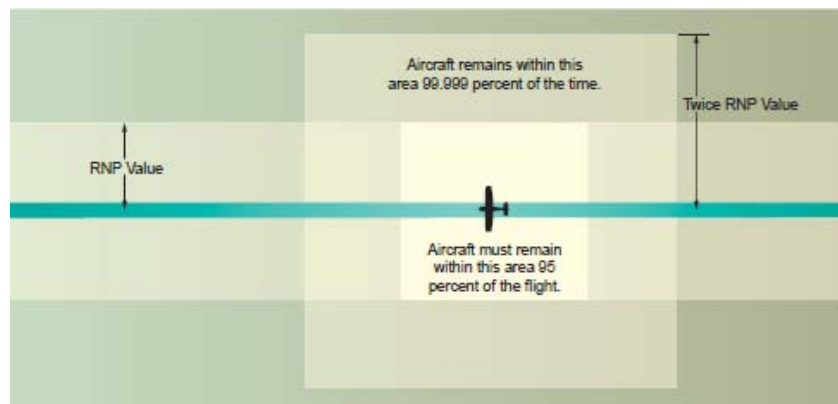

Figure 6. RNP Containment (DoT, 2007:Appendix B)

This aircraft containment area creates a tunnel for the aircraft to travel and is illustrated in Figure 7. Each tunnel in the sky would avoid other tunnels just as it would obstacles (Paylor, 2006:58)

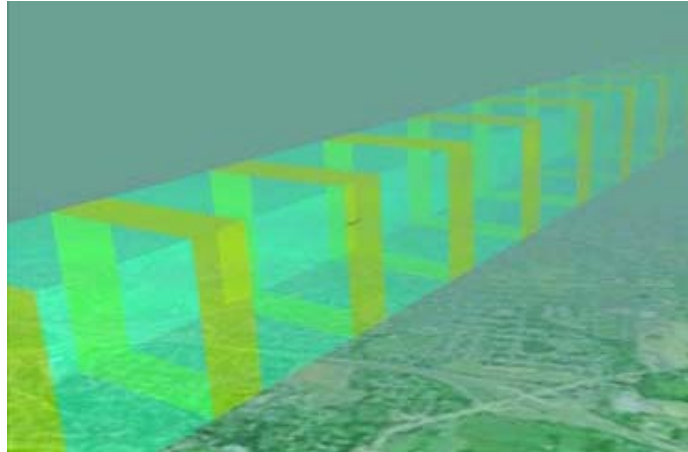

Figure 7. Tunnel in the Sky (DoT, 2006:6)

The RNP value for a specific procedure is dependent upon the accuracy needed for that operation. Precision approach procedures into an airfield require a much greater degree of accuracy than transoceanic flights. For example, in Figure 8, the aircraft would be required to fly RNP 0.5 for the initial segment to navigate through obstacles, but then would transition to RNP 1.0 for an area with wider spaced obstacles.

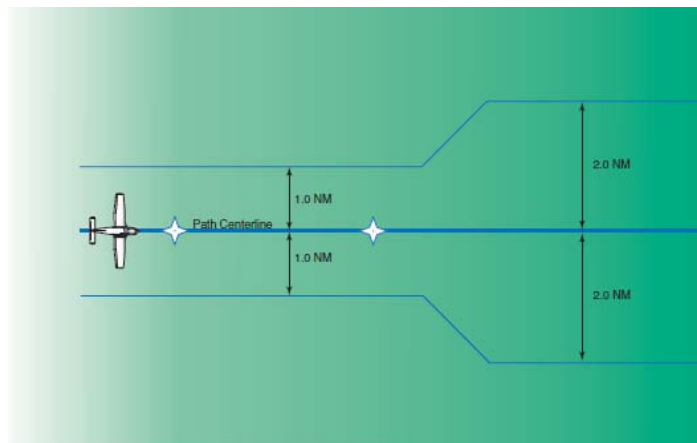

Figure 8. RNP Containment Zones (DoT, 2007:2-26)

A few example operations and their corresponding RNP values are shown in Table 1.

Table 1. RNP Operations and Required RNP Values (George, 2009:58)

RNP Value	Operations
RNP 4 to RNP 10	Enroute and Transoceanic
RNP 2 to RNP 5	Continental Airspace
RNP 0.1 to RNP 0.3	Precision Approach & Departure

RNP Monitoring

RNP operations not only require accuracy, but also integrity, availability and continuity of the system (EuroControl, 2003:5). Redundant systems ensure pilots are receiving legitimate data. A critical component of RNP is the ability to monitor the achieved navigation performance and alert the aircrew when these requirements are not being met (DoT, 2009:6). Figure 9 shows a typical alerting system display message to the pilot.



Figure 9. Alerting System when RNP is Exceeded. (DoT, 2007:Appendix B)

Many modern RNAV aircraft systems already have the required on-board monitoring and alerting systems which allows them to be designated as RNP (ICAO 9613, 2008:I-(v)). The specific RNP value it would achieve however depends upon the actual performance of the aircraft.

History of RNP

RNP operations were originally developed for transoceanic flights where NAVAIDS were not available (ATW, 2009:35). Terminal RNP operations were first developed by Alaska Airline pilots in order to decrease the number of diverted flights due to challenging terrain (Hutchinson, 2007:22). The procedures developed allowed accurate navigation through the mountains in poor weather. The first successful RNP approach was performed in 1996 (Andersen, 2002:38). Since that time, RNP has extended to other areas of flight and has become an integral part of aviation.

Collaboration

The evolution of RNP operations has become a critical part of international aviation transformations. US NextGen, Australian Air Traffic Management (ATM) Strategic Plan, and Single European Sky ATM Research (SESAR) include RNP procedures as part of their development to modernize air traffic control (AirServices Australia, 2008:5). The FAA plans to implement RNP-1 standard instrument departures at the busiest airport in the US with lower RNP values being implemented as needed (DoT, 2006:21). The international standards for RNP have been developed by the ICAO Special Committee on Future Air Navigation Systems (FANS) (DoT, Jun 2005:1-1).

Applications

RNP is on the brink of expansion because there are so many applications and benefits to this type of navigation (Andersen, 2002:38). Precise navigation means more aircraft can be handled in the same amount of airspace, adding to the capacity. RNP can be used to mitigate the effects of weather as well as restrictions on runway lengths (Carey, 2006:A.15). It is also being used for transoceanic flights with no radar coverage, precision approach, missed approach, enroute flight, surface movement, and obstacle avoidance. Examples of obstacles include physical structures, terrain, noise sensitive areas, residential neighborhoods, and no-fly zones. RNP is a critical technology that allows aircraft to fly much closer to each other or to obstacles with a greater level of safety than traditional navigation systems (George, 2009:58). It also has great potential to increase payload, which is the focus of this research (Andersen, 2002:38). Jet Blue airlines recognized this potential by implementing RNP departures out of Burbank, CA to avoid obstacles. Prior to using these departures, JetBlue had to stop on the way to the East coast to refuel or fly with 50 fewer passengers (Carey, 2006:A.15).

RNP Users

The primary user of RNP technology is the airline community because of the money-saving potential. There are multiple companies, such as Naverus and Jeppesen, in the US who have been certified by the FAA to develop RNP procedures (George, 2009:60). They have developed procedures for airlines in Canada, New Zealand, Australia, China and the US (ATW, 2009:35). Aircraft manufacturers are also pushing the technology along. Boeing and Airbus have already delivered aircraft with the equipment to support RNP 0.3 capabilities and are moving toward more precise

navigation with RNP 0.1 (Shawlee, 2008:46). Military aircraft have some RNP capability but the actual RNP value is dependent upon the airframe. As of the writing of this paper, the C-5A/B that have been upgraded through the avionics modernization program have the equipment to meet RNP levels between RNP 3 and RNP 10 (Turner, 2010).

Benefits

The impact of RNP operations has been significant. Alaska Airlines prevented 65 flight diversions in 2001 (Nordwall, 2002:45), 858 flight diversions in 2005 (Carey, 2006:A.15) and 980 flight diversions in 2006 (Hutchinson, 2007:22). The increased precision reduces air traffic controller workload and correspondingly voice transmissions have been cut by 30 to 50 percent using RNAV (Hughes, 2006:39). The accuracy of RNAV is best illustrated by using radar tracks. Figure 10 highlights the radar track of aircraft flying into Atlanta Hartsfield Airport with and without RNAV. The image on the left shows the radar tracks of individual aircraft without RNAV. Since the aircraft are flying by traditional navigational means, the resulting error prevents accurate flight paths. The image on the right shows radar tracks of individual aircraft after RNAV was implemented. Since aircraft flying RNAV operations are more precise, the intended flight path was followed with little error.

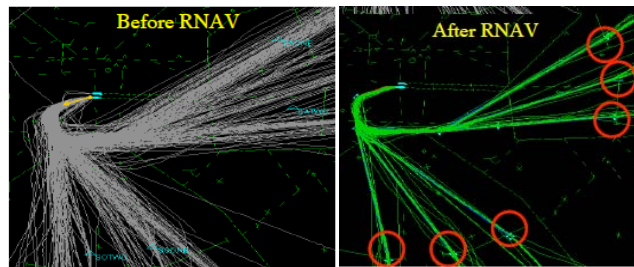

Figure 10. Atlanta Airport RNAV Radar Tracks (DoT, 2006:8)

This highlights RNAV's great benefit of repeatability and predictability. Another example is shown in Figure 11 where the radar tracks in green reveal the consistent RNP paths avoiding overflight of residential areas. The red radar tracks represent aircraft using traditional navigation.

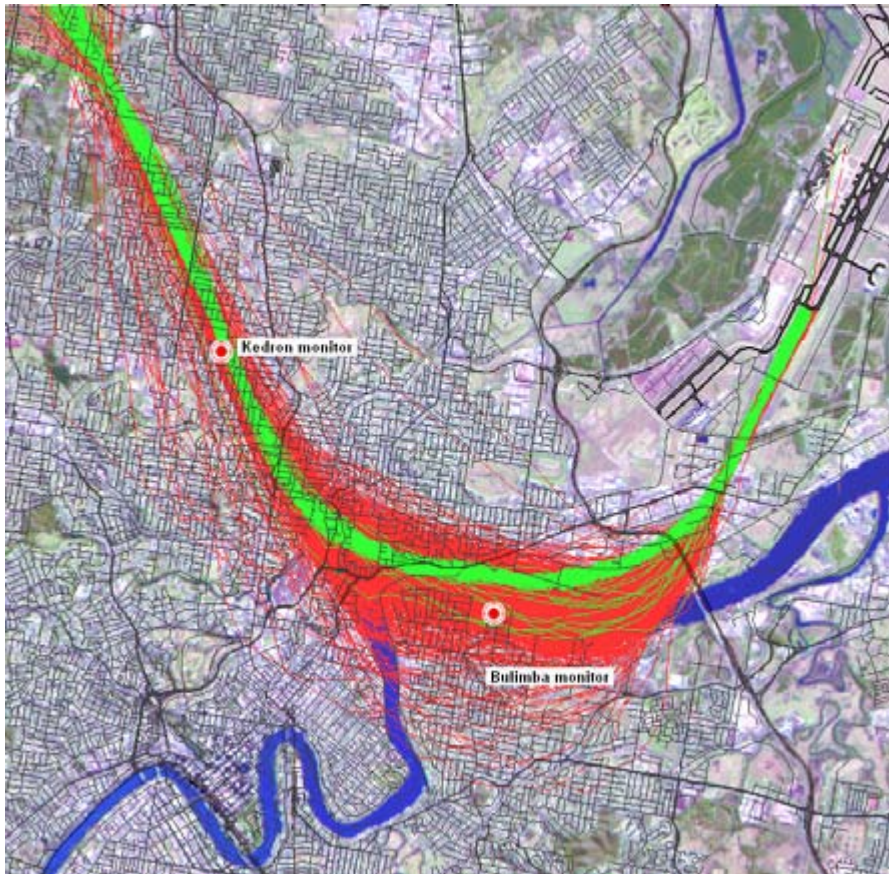

Figure 11. RNP versus Non-RNP Flight Paths (AirServices Australia, 2008:13)

Safety is a major concern when implementing any new technology, especially when the flight path brings the aircraft closer to obstacles. Because of the stringent requirements to receive certification as well as the redundant onboard monitoring systems, navigation with RNP is safer than it has been in the past. CFIT may be virtually eliminated because of RNP operations (Andersen, 2002:38). This accuracy has been confirmed by Australia's report evaluating the world's first international airport with full

integration of RNP approaches and departures (AirServices Australia, 2008:2). In the study conducted from August 2007 to January 2008, over 500 RNP flights were analyzed and found to have zero instances of an aircraft exceeding the flight tolerance (AirServices Australia, 2008:9). The aircraft conformed to their intended paths with a standard deviation of 0.0224 nautical miles.

Issues

With all new technologies, there are some issues with implementation of RNP. First, not all aircraft are equipped to take advantage of RNP (Carey, 2006:A.15). For some, it may be costly to retrofit to bring the aircraft up to standards (Paylor, 2006:58). Upgrades, however, take full advantage of existing avionics and equipment for integration, which lowers that total cost. Another concern is how the RNP flight paths are to be laid out. To exploit the greatest operational benefits, new routes would include curved approaches, parallel runway operations, and navigation through terrain. Unfortunately, the FAA is not always creating new, more efficient flight paths, but just overlaying RNP flight paths overtop of existing flight paths (Schofield, 2009:43). Although this is a concern for some procedures, such as enroute flights that would benefit from a new direct path, departure procedures could benefit just as much from the overlaid routes. The key to enhancing departures is to navigate between obstacles, changing the vertical profile, not necessarily the lateral path as depicted in Figure 12 (Schofield, 2009: 44).

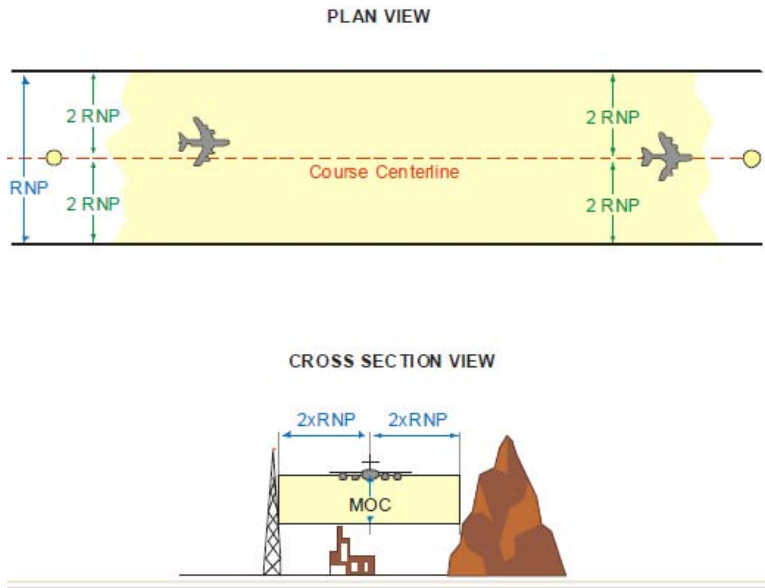

Figure 12. RNP Segment Width (ICOA 9905, 2008:27)

How to achieve RNP

Both the aircraft and aircrew must be qualified to be authorized to perform RNP procedures. In general, the underlying navigation system(s) employed is not mandated as long as the level of performance is achieved (Nordwall, 2002:45). For lower RNP values, however, critical systems need redundancy (Andersen, 2002:38). Where obstacles present an issue, as in a missed approach or an RNP departure, no single-point-of-failure can cause the loss of guidance (DoT, Dec 2005:Appendix 2:9). In these cases, aircraft will typically require a single inertial reference unit, dual autopilots, dual data systems, dual flight management systems and dual GNSS sensors (DoT, Dec 2005:Appendix 2:9). GPS augmentation provides enhanced accuracy by providing corrections to the GPS data through either ground based augmentation systems (GBAS) or Satellite based augmentation systems (SBAS). GBAS provides the highest level of accuracy, integrity, and continuity, but would be localized to the specific airfield. The

FAA's Local Area Augmentation System (LAAS) and the DoD's Joint Precision Approach and Landing System (JPALS) are GBAS systems. Many other countries, such as Australia, Norway, Germany and Russia use GBAS to increase precision at airfields. SBAS does not require airport-specific ground equipment, but do require regional reference stations to track GPS satellite signal errors and provide corrections through broadcasts from geosynchronous satellites. Currently, the FAA's SBAS system, called the Wide Area Augmentation System's (WAAS) coverage is limited to the US and parts of Canada and Mexico (DoT, May 2010). Similar SBAS systems either exist or are planned for other areas such as Europe, India, Japan and China. Installation of equipment by itself does not guarantee final approval for use. Some additional requirements include aircrew training, established maintenance procedures and participation in the RNP monitoring program. These requirements for special aircraft and aircrew authorization required (SAAAR) procedures are contained in Advisory Circular 90-101 appendix 7.

Takeoff Weight Limitations

There are many factors that limit the maximum allowable takeoff weight of an aircraft. Each airframe type will differ according to a variety of constraints. The total takeoff weight consists of the weight of fuel, cargo, passengers, and the aircraft itself. The C-5 aircraft was designed for a maximum takeoff weight of 769,000 pounds under optimal operating conditions during peacetime (DoAF, 2009). Taking off at this designed maximum weight is rare, however, because of real-world limiting factors.

The first set of constraints relate to the condition of the runway. These include slope, length, surface type and surface condition. Possible surface conditions are dry, patchy, wet, light snow, packed snow, slush and ice (Lockheed, 2008:A3-6). Another set

of variables stem from the environment. Wind direction and velocity, outside air temperature, pressure altitude and air density all have an effect. The condition of the aircraft also has an impact on the allowable weight. These conditions include the number of engines operating and engine thrust.

The final variable that affects maximum takeoff weight is the location of obstacles along the departure path. Out of all of the obstacles along the aircraft's flight path, there is only one that determines the climb gradient the aircraft needs to achieve in order to clear all of the obstacles. As long as the aircraft flies above this one obstacle, it will fly above all other obstacles. This obstacle is referred to as the controlling obstacle. The controlling obstacle is determined by comparing the height and distance from the end of the runway. For example, in Figure 13, the controlling obstacle is the tower on the mountain, eliminating the need to consider the building on the ground. All of these constraints were obtained from TO 1C-5a-1-1 and are summarized in Figure 14.

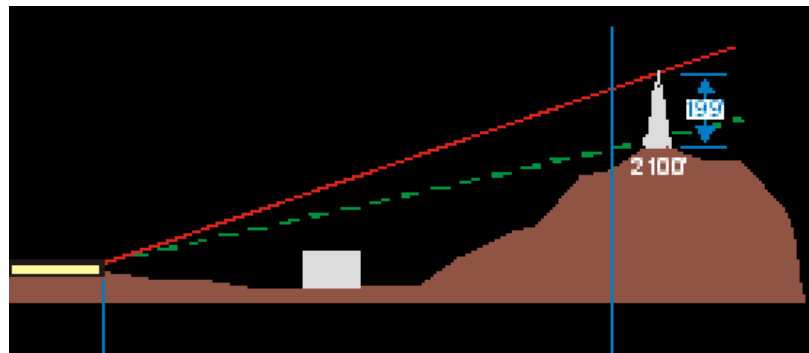

Figure 13. Controlling Obstacle Example (Modified from FAA order 8260.19d)

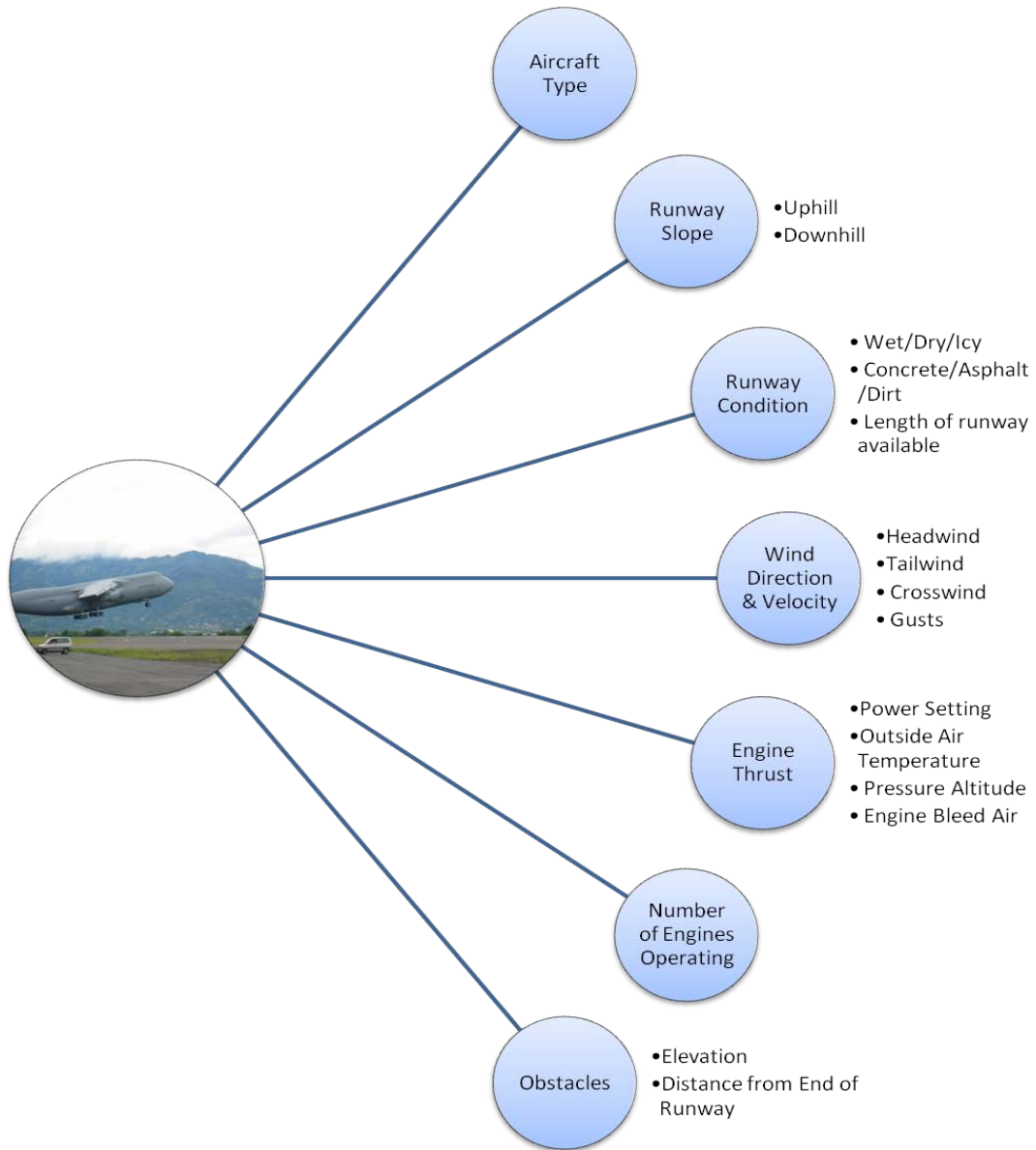

Figure 14. Factors Impacting Maximum Gross Takeoff Weight of an Aircraft

III. Methodology

“...instead of doing a turn inside an obstacle to avoid it, we can snake our way [through terrain] and extract ourselves that way.”

— *Jeff Martin*
Senior Director-Flight Operations, Southwest Airlines (Chandler, 2007:84)

The data used for this research was gathered from military operational sources. Many of the variables were assumed to be constant in order to provide a direct comparison of the two separate departure procedures. The results are repeatable since all of the variables used for the calculations were defined by predetermined values without random variability.

Takeoff Weight Calculation

The maximum gross takeoff weight was calculated using the C-5 TOLD Fuel Log Program version 3.6.2. This program is used operationally by C-5 flight engineers to balance all of the constraints involved in planning for takeoff (Turner, 2010). Although these calculations could have been interpolated from charts contained in Technical Order (TO) 1C-5a-1-1, only computerized results were used for this project. The 445th Airlift Wing at Wright Patterson AFB, OH provided access to the program and assisted in performing the calculations.

Sources of Constraints

Since there were a number of factors that affect the maximum gross takeoff weight, certain variables were held constant throughout the analysis. Pressure altitude was maintained at 29.92 inches mercury. Winds were assumed to be calm without

effecting aircraft performance. The runway was assumed to be paved and dry. The flaps for takeoff were set at 40 percent. The engine power was set to Takeoff Rated Thrust (TRT) standing, which maximizes power allowing a greater gross takeoff weight, but reduces engine life (Turner, 2010). Center of gravity was set at a standard 35 percent. Each of the calculations assumed an engine out departure, where only three engines were fully operational. These settings were selected at the recommendation of the flight engineer supporting the research.

Runway-specific constraints were also used for the calculations. The elevation of the field, the slope of the runway, the length of the runway and the elevation at the departure end of the runway (DER) were obtained from published FAA airport diagrams on the FAA website. The temperature ranges were selected based on typical weather at each airfield. Data was collected over the temperature ranges in five degree increments.

Obstacle Data

The controlling obstacle's height and distance from DER were determined for each departure procedure at all three airfields. For the selected runway at Canberra, Australia, these values were obtained from the published climb gradients (AirServices Australia, 2009). To calculate the height of the controlling obstacle at one nautical mile out from the DER, the value of the climb gradient was multiplied by one nautical mile and added to the elevation of the DER. For example, the required climb gradient for the RNP 0.3 departure was 460 feet per nautical mile and the elevation of the departure end of the runway was 1886 feet, resulting in a controlling obstacle height of 2346 feet, one nautical mile from the DER. The values for the SID were calculated in the same manner.

An alternative method was used to determine the obstacle data for the selected runways at Nellis AFB and Jackson Hole. Obstacles along the departure path were identified using the Instrument Procedure Designer program. This program contains a comprehensive database of obstacles surveyed at airfields throughout the US and is used by air traffic controllers to develop instrument approach and departure procedures for the USAF. Headquarters Air Force Material Command A3O provided access to the system and assisted in gathering the data. By entering the route for the SID, the program automatically displayed the resulting departure segment including splay lines angling out from the DER. The program also highlighted the controlling obstacle within the departure segment. Figure 15 displays the departure segment for Jackson Hole, WY with the controlling obstacle identified by the bold carrot symbol.

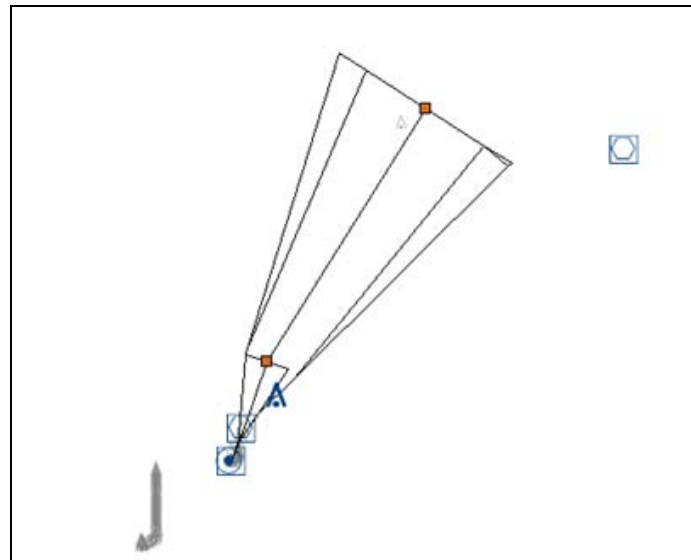

Figure 15. Departure from Jackson Hole in Instrument Design Procedure
Once the controlling obstacle was found, the height and distance from DER was measured using the program's range and bearing tool. These height and distance measurements are approximate, not exact values.

The RNP 0.3 departure paths for Nellis AFB and Jackson Hole were developed using the criteria established for RNP approach procedures since published departure procedures do not exist for those locations. The width of the departure segment was set at 1.2NM, which is four times the RNP value with no angled splay. Similar to the procedure used for the SID, the highest obstacle in the departure segment was identified using the Instrument Procedure Designer program and the height and distance from DER was measured using the range and bearing tool. These height and distance measurements are approximate, not exact values. A summary of all the variables and constraints used in the calculations are summarized in Table 2.

Table 2. Variable Settings Used in Calculations for Max Gross Takeoff Weight

Factors	Setting at Nellis AFB, NV	Setting at Jackson Hole, WY	Setting at Canberra, Australia
Pressure Altitude	29.92 inches Hg	29.92 inches Hg	29.92 inches Hg
Winds	Calm	Calm	Calm
Runway Conditions	Paved/Dry	Paved/Dry	Paved/Dry
Flaps at takeoff	40%	40%	40%
Engine Power	TRT Standing	TRT Standing	TRT Standing
Center of Gravity	35%	35%	35%
Field Elevation	1870 ft	6451ft	1886 ft
# of Engines Operating	3	3	3
Runway Elevation (DER)	1870 ft	6451ft	1886 ft
Slope of Runway	0.3° Up	0.6° Up	0°
Runway Length	10,000 ft	6,300 ft	10, 738 ft
Height of Controlling Obstacle for SID	11,506 ft	7256.46 ft	2446 ft
Controlling Obstacle Distance from DER, SID	15.43 NM	2.31 NM	1 NM
Height of Controlling Obstacle for RNP 0.3 Departure	2179 ft	6823.23 ft	2346 ft
Controlling Obstacle Distance from DER, RNP 0.3 Departure	1.79 NM	2.36 NM	1 NM
Temperature Range (in 5° increments)	40° to 110° F	-10° to 80° F	0° to 100° F

Once the variables were collected, the maximum allowable weights for each departure were calculated in the C-5 TOLD Fuel Log program. Clearance above the controlling obstacle was factored in the calculations. The weight difference between the SID and the RNP 0.3 departure were then compared directly since all other factors were equal.

IV. Results and Analysis

“We have to get out of the mind-set of saying, ‘No matter how hard we try, we will have accidents,’ and into ‘We will not have accidents.’”

— *Federico Peña, U.S. Transportation Secretary, Safety conference speech, January 1995*

Results

All calculations were verified with a C-5 flight engineer to ensure the values and trends in the data were reasonable. For example, it is normal for the maximum takeoff weight to decrease as temperature increases (Turner, 2010). Also, the takeoff weight leveled out at lower temperatures because the limiting factor transferred from temperature to other constraints such as runway length. The raw data is contained in the excel spreadsheet in Appendix B. The specific calculations were meant to show a comparison between the two departure types and were not intended to be exact numbers for operational use.

As predicted, the gross takeoff weight was consistently higher for the RNP 0.3 departures at all three airfields analyzed as indicated in Figures 16, 17, and 18.

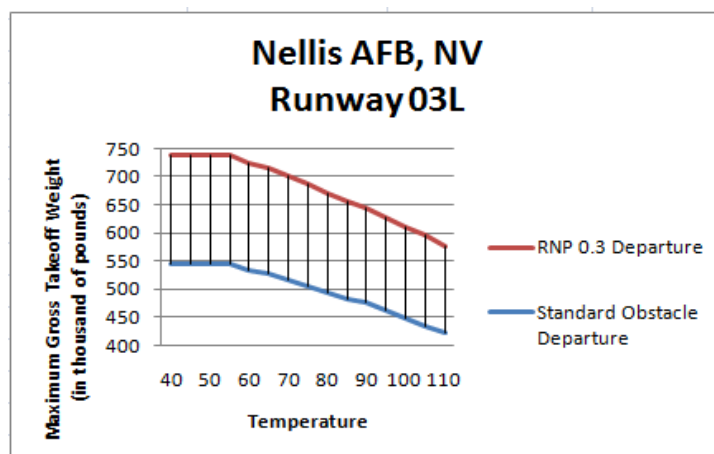

Figure 16. Comparing Takeoff Weights for C-5 Aircraft at Nellis AFB, NV

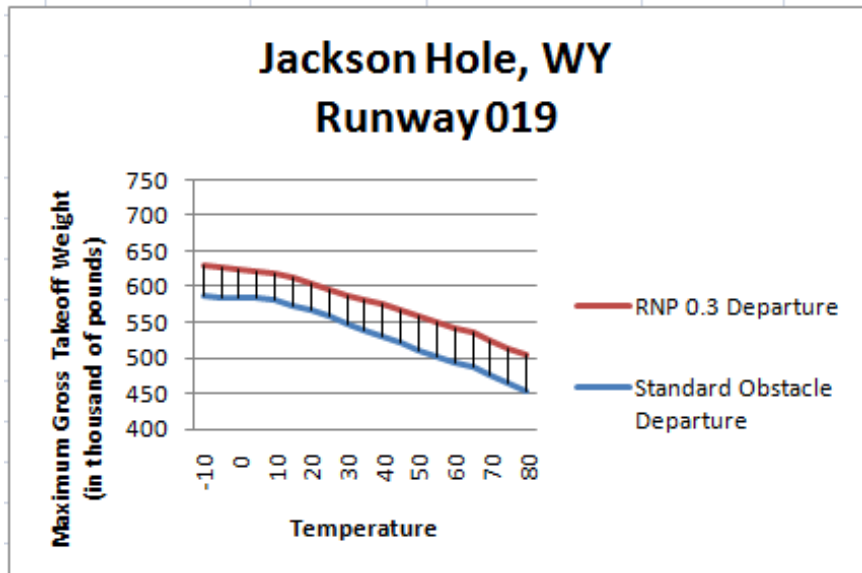

Figure 17. Comparing Takeoff Weights for C-5 Aircraft at Jackson Hole, WY

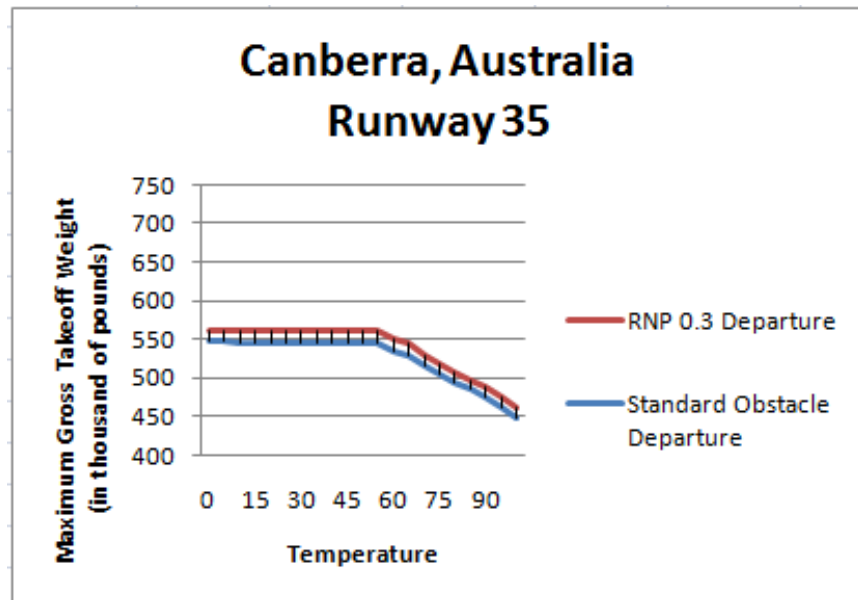

Figure 18. Comparing Takeoff Weights for C-5 Aircraft at Canberra, Australia

The total increase in weight depends upon the specific airfield with the average increases summarized in Table 3. To make a broad comparison, a full fuel load for the C-5 weighs

332,500 pounds (DoAF, 2009). An increase of 179,000 pounds at Nellis AFB, NV would therefore be about half of the maximum possible fuel load.

Table 3. Average Weight Increase by Using RNP 0.3 Departure

Location	Average Increase in Gross Takeoff Weight
Nellis AFB, NV	179,000 lbs
Jackson Hole, WY	44,000 lbs
Canberra, Australia	14,000 lbs

Interpreting Obtained Results

The reason each airfield had a different weight increase was because of the differences in how much change was made to the controlling obstacle height and location. For instance, at Nellis AFB, the height decreased by about 9,000 feet and distance decrease by about 13 miles. At Canberra, on the other hand, the change in height only decreased by 100 feet, which still resulted in a gain of 14,000 pounds. Despite these vast differences between fields, the results at each field were consistent over the temperature range analyzed. The percentage increase from the SID to the RNP 0.3 departure is illustrated in Figure 19.

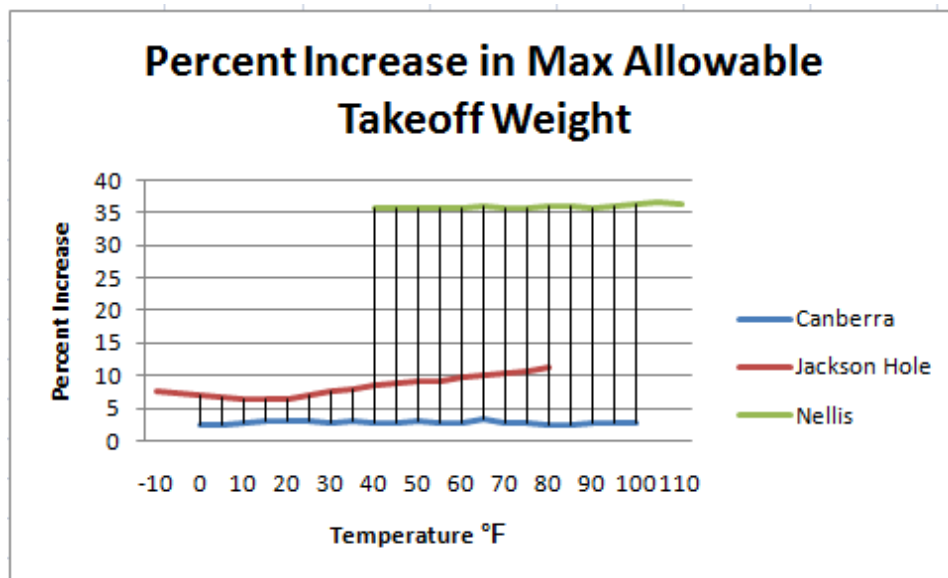

Figure 19: Percent Increase in Gross Takeoff Weight for C-5 Aircraft

V. Discussion

“If you are looking for perfect safety, you will do well to sit on a fence and watch the birds; but if you really wish to learn, you must mount a machine and become acquainted with its tricks by actual trial.”

— *Wilbur Wright, from an address to the Western Society of Engineers in Chicago, 18 September 1901*

Relevance of this study

Increasing the maximum gross takeoff weight of an aircraft is achievable through the improved precision provided by RNP 0.3 departures. Although the results were focused on the C-5 aircraft at specific locations, the advantages can be extended to other airframes, both military and civilian where takeoff weight is a limiting factor. The benefits are only possible in locations where obstacles off the DER prevent an optimal climb rate of 200 feet per nautical mile for a standard instrument departure and where the increased precision of the RNP 0.3 departure allows the aircraft to fly between obstacles rather than over them (DoT, 2000:2-12).

This increase in maximum gross takeoff weight is just one unintended benefit of RNP procedures. Upgrades to avionics to achieve an RNP 0.3 departure will also enhance areas such as approach operations, enroute flights, and safety. When comparing the cost of upgrading the aircraft to a fully operational system, all of the increased benefits should be compared together rather than in isolation. Also, the timeline should also be considered when planning for upgrades. It takes about five years to retrofit all of the existing aircraft since they cannot all be upgraded simultaneously. Because of this extensive timeline, it is practical to perform multiple upgrades at once.

Military Application

Even though the airline industry will benefit the greatest in terms of profit, the DoD can realize the advantages through mission performance. Allowing an increased takeoff weight can get more assets into theater faster. Additionally, when there is a significant increase in weight, as shown with the data at Nellis AFB, NV, it may be possible to reduce the total number of aircraft required to transport equipment. Although the C-5 aircraft will likely have the most benefit in terms of total weight increase, it may not be the airframe that would practically benefit the most. A C-130 aircraft, for example, has a smaller capacity than a C-5 aircraft and would therefore run into the scenario where maximum takeoff weight is a limiting factor more often.

Another factor the DoD must take into account is the added requirement for secure military operations. Although the civilian version of equipment may be readily available off the shelf, the military version may have to be developed and tested. For instance, the LAAS ground systems are currently operational; however JPALS will have to be contracted out for development and testing.

Additional areas of study

Since there are a number of variables that impact gross takeoff weight of an aircraft, further analysis could be conducted by changing the inputs to the system. It would also be useful to gather information on where gross takeoff weight becomes a limiting factor, as well as the frequency of this issue, and perform the analysis for those aircraft at the identified locations. More importantly, the results of this study and any other follow on studies in this area need to be combined with an overall analysis of the total benefits gained through avionics upgrades.

Conclusion

Modernized avionics equipment combined with precise GPS signal can have an impact in more ways than just better navigational accuracy. This study revealed that there are innovative ways to use the enhanced technology. The maximum gross takeoff weight of an aircraft can be increased with even a modest change in climb gradient. In an era where efficiency is critical, allowing a greater takeoff weight could have an certainly have an impact on military operations.

Appendix A
Published RNP 0.3 Departure Procedure Canberra, Australia
 (AirServices Australia, 2009)

NAVERUS **DO NOT USE FOR NAVIGATION** **CURTN FOUR DEPARTURE**
CANBERRA, ACT (YSCB)

REVISION: upnumber departure name text.

Apt Elev	Trans ALT	ATIS (*AWIS AH)	ACD/SMC	TWR	DEP	CTAF (AH)
1888'	10000'	118.7* 127.45	121.7	118.7	East 124.5 West 125.9	118.7 (R)

CURTN FOUR RNAV (RNP) DEPARTURE RNP 0.30 (CURTN4.CB677) RWY 17

Requires weather minima of 0' ceiling / 400 meters visibility.

HOWLY, WG, NONUP and TANTA transitions require a minimum climb gradient of 460' per NM to 2900'.

YAS and CULIN Transitions require a minimum climb gradient of 600' per NM to 8000'.

TAKE-OFF:

RWY 17: Fly RNAV (RNP) track to CURTN. Cross CURTN at or above 2900'. Thence:

TRANSITIONS:

HOWLY: Fly RNAV (RNP) track to CB689. From CB689, follow the depicted route to HOWLY.

WG: Fly RNAV (RNP) track to CB689. From CB689, follow the depicted route to WG VOR.

NONUP: Fly RNAV (RNP) track to CB689. From CB689, follow the depicted route to NONUP.

TANTA: Fly RNAV (RNP) track to CB689. From CB689, follow the depicted route to TANTA.

CULIN: Fly RNAV (RNP) track to CULIN. Cross CB683 at or above 8000'.

YAS: Fly RNAV (RNP) track to YAS. Cross CB683 at or above 8000'.



LOST COMMUNICATION:

On recognition of communication failure:

- Squawk 7600
- Climb to minimum safe altitude to maintain terrain clearance
- Proceed in accordance with the latest ATC route clearance acknowledged

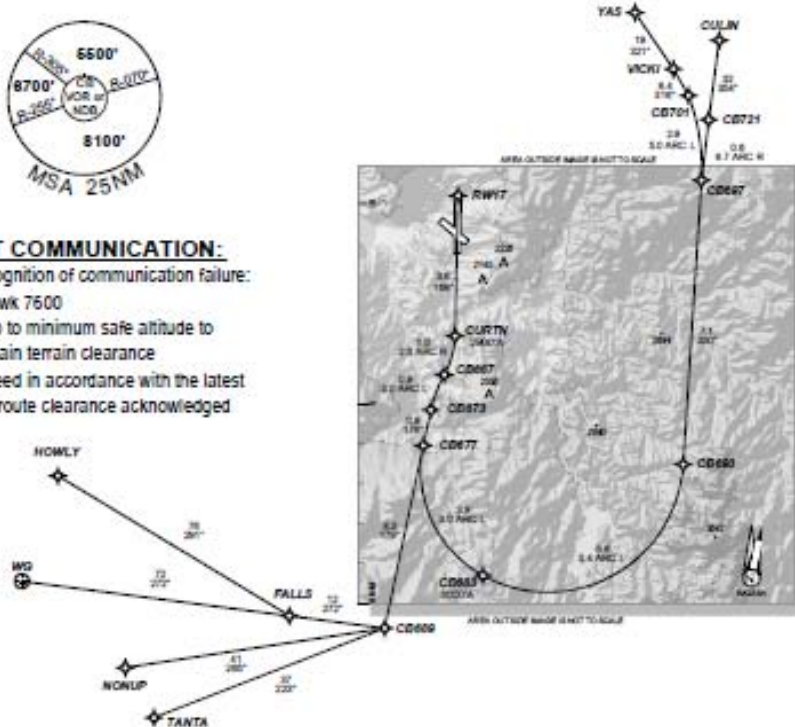

FOR CASA APPROVED OPERATORS ONLY

Plotfile: 12/25/2008

© NAVERUS, INC., 2008. ALL RIGHTS RESERVED.

26 DEC 2008

CURTN FOUR DEPARTURE
CANBERRA, ACT (YSCB)

**Appendix B
Data Results for Analysis**

Nellis		Nellis		Jackson Hole		Jackson Hole		Canberra		Canberra	
Nellis	Std Departure	RNP 0.3 Departure	Jackson Hole	Std Departure	RNP 0.3 Departure	Jackson Hole	Std Departure	Temp (° F)	Std Departure	RNP 0.3 Departure	Temp (° F)
Temp (° F)	MGW (in 1000s of lbs)	MGW (in 1000s of lbs)	Temp (° F)	MGW (in 1000s of lbs)	MGW (in 1000s of lbs)	Temp (° F)	MGW (in 1000s of lbs)	Temp (° F)	MGW (in 1000s of lbs)	MGW (in 1000s of lbs)	Temp (° F)
			-10	586.2	630.2						
			-5	584.2	627.7						
			0	584.2	624.5			0	547.2	561.2	
			5	583.2	621.4			5	547.2	561.2	
			10	581.2	617.6			10	546.2	561.2	
			15	574.2	611.4			15	545.2	561.2	
			20	567.2	603.8			20	545.2	561.2	
			25	557.2	596			25	545.2	561.2	
			30	547.2	588.5			30	546.2	561.2	
			35	539.2	581.5			35	545.2	561.2	
40	545.2	739.2	40	531.2	575.8			40	546.2	561.2	
45	545.2	739.2	45	521.2	567			45	546.2	561.2	
50	545.2	739.2	50	511.1	557.8			50	545.2	561.2	
55	544.2	739.2	55	502.2	548.8			55	545.2	560.2	
60	533.2	724.2	60	492.2	540.6			60	535.2	549.2	
65	527.2	716.2	65	486.2	534.8			65	528.2	545.2	
70	516.2	700.2	70	475.2	523.7			70	516.2	530.2	
75	505.2	686.2	75	465.2	514.2			75	505.2	519.2	
80	493.2	670.2	80	453.2	504.2			80	495.2	507.2	
85	482.2	655.2						85	485.2	496.2	
90	475.2	645.2						90	476.2	489.2	
95	461.2	627.2						95	462.8	475.2	
100	447.2	610.2						100	449.2	461.2	
105	435.2	595.2									
110	422.2	575.2									

Appendix C Abbreviations

AC – Advisory Circular
AFB – Air Force Base
ATM – Air Traffic Management
CFIT – Controlled Flight Into Terrain
DER – Departure End of the Runway
DoAF – Department of the Air Force
DoD – Department of Defense
DoT – Department of Transportation
FAA – Federal Aviation Administration
FANS – Future Air Navigation System
FSF – Flight Safety Foundation
GAO – General Accounting Office
GBAS – Ground-Based Augmentation System
GNSS – Global Navigation Satellite System
GPS – Global Positioning System
ICAO – International Civil Aviation Organization
LAAS – Local Area Augmentation System
NAVAID – Navigation Aid
NextGen – Next Generation Air Transportation System
NM – Nautical Mile
OAA – Obstacle Avoidance Area
PBN – Performance Based Navigation
RNAV – Area Navigation
RNP – Required Navigation Performance
SAAAR – Special Aircraft and Aircrew Authorization Required
SBAS – Satellite-Based Augmentation System
SESAR – Single European Sky ATM Research
SID – Standard Instrument Departure
TO – Technical Order
TRT – Takeoff Rated Thrust
TSE – Total System Error
USAF – United States Air Force
WAAS – Wide Area Augmentation System

Appendix D Blue Dart

Maj Tracy Hunter, Student, AFIT
785-3636, tracy.hunter@afit.edu
word count: 718

Leading Edge or Flying Behind?

The Air Force has a reputation for leading the way in technology, specifically in the area of aviation. Recently, however, there has been evidence that the other military services and the commercial industry may be taking the initiative in driving the train. Consider aircraft avionics upgrades. Airlines are jumping at the opportunity to install the avionics to capture the benefits of GPS augmentation. Since GPS alone is not accurate enough for precise operations such as precision approach, an augmentation system such as Ground Based Augmentation System (GBAS) is needed. This technology not only replaces the need for traditional equipment, but also provides enhanced benefits such as increased safety, flexibility in aircraft routing and increased gross takeoff weight. The technology is so mature that Boeing and Airbus consider the avionics standard options for new aircraft.

The international community has also embraced the technology. Australia has published arrival and departure procedures that only aircraft equipped with this capability can use. GBAS systems are being implemented world-wide. There is even an International GBAS Working Group, a multinational organization with participation from governments, airlines and industry.

So why is the Air Force so hesitant to jump on board? One problem is the fear of investing in a technology that is not 100% guaranteed to become the international

standard. It is an issue that haunts the AF with the microwave landing systems, which became military-unique when it did not become the official standard. Procedures, however, are becoming performance-based, so there are no longer mandates on how the performance is achieved as long as the specified level of performance is met. So the fear to invest in technology such as GBAS that provides enhanced performance should no longer be a concern.

The biggest roadblock seems to be the way the AF establishes priorities. There is no centralized office for aircraft avionics, like the Army and Navy. Each airframe is responsible for prioritization of how and when avionics are to be modernized. Although this may appear a good way of doing business on the surface, it becomes a nightmare when it comes to standardization of common avionics. And to top it off, funding is no longer dedicated to making upgrades. Program office leadership must decide between leading the way with avionics modernization or perhaps an engine upgrade. Not much of a decision.

Probably the best example is the Joint Precision Approach and Landing System (JPALS), the military version of GBAS. The formal need for the system was validated by the Joint Requirements Oversight Council (JROC) in 2009 and pilots who have flown the civilian version have experienced the benefits first-hand. The technology is mature because the program has been stuck in the technology development phase for over ten years due to lack of funding. The Navy is already on contract for the development of the Sea-Based version of JPALS. So where is the AF, who is the responsible for funding and leading the development of the ground-based JPALS system for all of the services? It was funded in 2008, however the funding was pulled because of other priorities. Part of

the reason is that individual platforms aren't equipped with the avionics to use the ground stations. It is unreasonable to ask a decision maker for an individual airframe to prioritize an avionics upgrade for a ground system that doesn't exist. But without that prioritization, the funding for the ground systems is no longer a priority. It is the chicken and the egg scenario: which comes first?

In order for the AF to solve this issue, both organizational changes need to be made as well as method of funding. Rather than allocating funds to the individual program office, a separate program element funding line should be established for avionics upgrades. This would allow upgrades to be accomplished without direct funding competition for other aircraft upgrades. Also, a completely separate avionics program office should be established to ensure necessary upgrades are made universally across the appropriate platforms.

Leading the way means pressing forward with smarter ways of doing business. The AF has successful examples of ways to organize from the Army and Navy. In cases like the JPALS example, where other services are relying on the AF, this change in organization is essential.

The views expressed in this article are those of the author and do not reflect the official policy or position of the United States Air Force, Department of Defense, or the US Government.

Bibliography

- AirServices Australia. *RNP Project Brisbane Green Stage One Report*. March 2008.
- AirServices Australia. Aeronautical Information Package, 2009 Supplements
<http://www.airservicesaustralia.com/publications/aip.asp?pg=50>. 9 January 2009.
- Andersen, John A, Stephen D. Fulton, John H. Andersen. "Tighter Air Control,"
American Society of Mechanical Engineers, 124 Iss. 7: 38-41 (July 2002).
- "Aviation Technology Achievement: Naverus," *Air Transport World*, 46, Iss.2: 35
(February 2009).
- Carey, Susan. "Cleared for Landing; New Technology Lets Planes Arrive and Depart
Airports with Fewer Delays, Diversions," *The Wall Street Journal (Eastern
edition)*, 12 May 2006, sec. A.15.
- Cassell, Rick and Smith, Alex. *Development for Required Navigation Performance
(RNP) Requirements for Airport Surface Movement Guidance and Control*. AIAA.
Presented at the 14th Digital Avionics Systems Conference, November 1995.
- Chandler, Jerome Greer. "Southwest Bests Big on RNP," *Air Transport World*. 44, Iss.9:
83-83 (September 2007).
- Chiles, Patrick. *Planning the Departure*, Flight Safety Foundation, Aerosafety World,
July 2007.
- Department of the Air Force. "C-5 Galaxy Factsheet,"
<http://www.af.mil/information/factsheets/factsheet.asp?id=84>. Scott AFB, IL: HQ
AFMC, 5 June 2009.
- Department of Transportation. *Approval Guidance for RNP Operations and Barometric
Vertical Navigation in the US National Airspace System*, AC 90-105, 23 January
2009.
- Department of Transportation. *Approval Guidance for RNP Procedures with SAAAR*, AC
90-101, 15 December 2005.
- Department of Transportation. *Civil Utilization of Area Navigation (RNAV) Departure
Procedures*. Order 8260.44A Oklahoma City, OK: FAA Flight Procedure Standards
Branch, 23 March 2000.
- Department of Transportation. *FAA's NextGen Implementation Plan*, Washington, DC:
March 2010.

- Department of Transportation. *Instrument Procedures Handbook*. FAA-H-8261-1A. Oklahoma City, OK: 2007.
- Department of Transportation. *Navigation Services*, http://www.faa.gov/about/office_org/headquarters_offices/ato/service_units/techops/navservices/gnss/. 4 May 2010.
- Department of Transportation. *Roadmap for Performance-Based Navigation, version 2.0*. Washington DC: July 2006.
- Department of Transportation. "United States Standard for Required Navigation Performance (RNP) Approach Procedures with Special Aircraft and Aircrew Authorization Required (SAAAR)," *Order 8260.52* Oklahoma City, OK: FAA Flight Procedure Standards Branch, 3 June 2005.
- Eurocontrol. "Guidance Material for the Design of Terminal Procedures for Area Navigation," Edition 3.0 European Organization for the Safety of Air Navigation, March 2003.
- Flight Safety Foundation (FSF) Editorial Staff. "Noncompliance with Departure Procedures Sets Course for Impact with Mountain," *FSF: Accident Prevention*, 57 No. 5 (August 2000).
- General Accounting Office. *Performance Capabilities of the C-5 and C-17 Cargo Aircraft*, GAO/NSIAD-84-119, 9 July 1984.
- George, Fred. "RNP Approach and Departure Procedures," *Business & Commercial Aviation*, 104 Iss. 2: 58-62 (February 2009).
- Hughes, David. "Precision Departures at DFW," *Aviation Week & Space Technology*, 162 Iss. 2: 39 (January 2006).
- Hutchinson, Harry. "Flight Guidance System Gaining in US," *Mechanical Engineering*, 129, Iss. 10: 22-23 (October 2007).
- International Civil Aviation Organization (ICAO). *Performance-based Navigation Manual, 3rd Edition*. Doc 9613 AN/937. Montreal, Quebec, Canada: 2008.
- International Civil Aviation Organization (ICAO). *Required Navigation Performance Authorization Required Procedure Design Manual*. Doc 9905-AN/471. Final Draft Ver 1.0: 24 (April 2008).
- Hughes, David. "Precision Departures at DFW," *Aviation & Space Technology*, 164, Iss. 2: 39 (9 January 2006).

- Lockheed Martin Aeronautics Company. *Technical Order TO 1C-5a-1-1, Flight Manual Appendix 1 Performance Data*. Robins AFB, GA: 1 December 2008.
- Nordwall, Bruce D. "US Changing to One Type of Instrument Approach," *Aviation Week & Space Technology*, 157 Iss. 2: 45 (8 July 2002).
- Paylor, Anne. "Tunnels in the Sky," *Air Transport World*, 43, Iss.1: 57-59 (January 2006).
- "Ready for Takeoff," *The Economist*, 383, Iss. 8533: 10 (16 June 2007).
- Roberts, Wally. "Advanced RNAV Procedures on the Horizon," *Business & Commercial Aviation*, 96 Iss.6: 42-45 (June 2005).
- Roberts, Wally. "Some Ways and Whys of RNP Approach Authority," *Business & Commercial Aviation*, 102, Iss. 5: 42-46 (May 2008).
- Schofield, Adrian. "Approach Arguments," *Aviation Week and Space Technology*, 171, Iss.6:43-44 (10 August 2009).
- Shawlee, Walter. "RNP: The World of Required Navigation Performance," *Aviation News*: 44-48, January 2008.
- Tarbert, Bruce. Department of Transportation. *Area Navigation (RNAV) and Required Navigation Performance (RNP)*. Address to CDA Workshop. 19 January 2006.
- Toydas, Murat, Alan W. Johnson, and Doral Sandlin. *Fuel Savings Opportunities from Air Refueling*. MS Thesis, AFIT/LSCM/ENS/10-12. Department of Operational Sciences, Air Force Institute of Technology (AU), Wright Patterson AFB OH, March 2010.
- Turner, Jeremy. C-5 Flight Engineer, 89th Airlift Squadron, 445th Airlift Wing, Wright Patterson AFB, OH. Personal Interview. 11 May 2010.

Vita

Major Tracy N. Hunter entered the Air Force through the Reserve Officer Training Corps in 1998 upon graduating from the University of Illinois with a Bachelor of Science in Electrical Engineering. In her initial assignment at Davis Monthan AFB, AZ, she led 140 maintenance personnel in the launch, recovery and repair of EC-130 and A-10 aircraft while managing \$344 million in aircraft assets. She was responsible for generating 956 sorties, resulting in 4,407 flying hours. As a career broadening assignment, Major Hunter then served as Chief of Standardizations and Evaluations, directing 2,457 Search and Rescue (SAR) missions, saving 226 lives CONUS-wide at the Air Force Rescue Coordination Center at Langley AFB, VA. In her next assignment to Eglin AFB, FL she directed \$388M in research and engineering activities for the development of the Small Diameter Bomb. She was subsequently handpicked as the executive officer for the 308th Armament Systems Wing where she led two hurricane evacuations with 100 percent accountability. Prior to her selection to AFIT, she was assigned to Hanscom AFB, MA where she negotiated an acquisition contract close out, saving the Air Force \$41M in termination claims. She also led a 30-member interagency team in the development of a \$230M acquisition strategy for the development of the next generation of GPS-based precision landing capability for 167 DoD airfields globally.

Major Hunter is acquisition certified to level III in Program Management, level II in Systems PRDE, and level I in Test. Her experience spans four career fields and four MAJCOMs. Following AFIT, Major Hunter will be assigned to the Joint Warfare Analysis Center, JFCOM at Dahlgren Naval Support Facility.

REPORT DOCUMENTATION PAGE

Form Approved
OMB No. 074-0188

The public reporting burden for this collection of information is estimated to average 1 hour per response, including the time for reviewing instructions, searching existing data sources, gathering and maintaining the data needed, and completing and reviewing the collection of information. Send comments regarding this burden estimate or any other aspect of the collection of information, including suggestions for reducing this burden to Department of Defense, Washington Headquarters Services, Directorate for Information Operations and Reports (0704-0188), 1215 Jefferson Davis Highway, Suite 1204, Arlington, VA 22202-4302. Respondents should be aware that notwithstanding any other provision of law, no person shall be subject to a penalty for failing to comply with a collection of information if it does not display a currently valid OMB control number.

PLEASE DO NOT RETURN YOUR FORM TO THE ABOVE ADDRESS.

1. REPORT DATE (DD-MM-YYYY) 06-08-2010		2. REPORT TYPE Graduate Research Project		3. DATES COVERED (From – To) Mar 2010 – Jun 2010	
4. TITLE AND SUBTITLE PERFORMANCE OF MILITARY CARGO AIRCRAFT USING REQUIRED NAVIGATION PERFORMANCE DEPARTURES				5a. CONTRACT NUMBER	
				5b. GRANT NUMBER	
				5c. PROGRAM ELEMENT NUMBER	
6. AUTHOR(S) Hunter, Tracy, N., Major, USAF				5d. PROJECT NUMBER	
				5e. TASK NUMBER	
				5f. WORK UNIT NUMBER	
7. PERFORMING ORGANIZATION NAMES(S) AND ADDRESS(S) Air Force Institute of Technology Graduate School of Engineering and Management (AFIT/EN) 2950 Hobson Street, Building 641 WPAFB OH 45433-7765				8. PERFORMING ORGANIZATION REPORT NUMBER AFIT-IOA-ENS-10-07	
9. SPONSORING/MONITORING AGENCY NAME(S) AND ADDRESS(ES) HQ AFFSA/A3/8 Attn: Ms. Tammy Place 7919 Mid America Blvd, Suite 300 DSN: 884-4231 Oklahoma City, OK 73135 e-mail: Tammy.Place@tinker.af.mil				10. SPONSOR/MONITOR'S ACRONYM(S)	
				11. SPONSOR/MONITOR'S REPORT NUMBER(S)	
12. DISTRIBUTION/AVAILABILITY STATEMENT APPROVED FOR PUBLIC RELEASE; DISTRIBUTION UNLIMITED.					
13. SUPPLEMENTARY NOTES					
14. ABSTRACT <p>Maximum takeoff weight for cargo aircraft is affected by many factors including the aircraft's ability to safely climb out to altitude. When there are obstacles in the departure path, the total weight of the aircraft may have to be reduced to ensure the aircraft will achieve the appropriate climb rate to clear the obstacles. During times of limited visibility, aircrews traditionally rely on predetermined departure paths limited by the aircraft navigation capability and the ground based navigation aids. A Required Navigation Performance (RNP) departure with accuracy down to 0.3 mile could allow the aircraft to safely navigate around obstacles with better precision, allowing a greater takeoff weight.</p> <p>This study compared current instrument departure procedures with predicted RNP 0.3 departures by computing the maximum allowable weight limit for the C-5 aircraft under a range of operating temperatures at three separate locations. The results showed that an increased precision of the RNP 0.3 departures had an operational advantage by allowing an increased cargo, passenger, or fuel load. The amount of weight increase was dependent upon a variety of factors, to include airframe type and location. To receive certification from the FAA to fly RNP 0.3 procedures, specific requirements such as training and equipment are necessary. Current configurations of the C-5 aircraft do not support RNP 0.3 procedures.</p>					
15. SUBJECT TERMS Required Navigation Performance (RNP), Area Navigation (RNAV), Maximum Gross Takeoff Weight, Cargo Aircraft, Precision Departures, Terminal Operations, Federal Aviation Administration					
16. SECURITY CLASSIFICATION OF:			17. LIMITATION OF ABSTRACT	18. NUMBER OF PAGES	19a. NAME OF RESPONSIBLE PERSON
a. REPORT	b. ABSTRACT	c. THIS PAGE			Raymond R. Hill, PhD, ENS
U	U	U	UU	55	19b. TELEPHONE NUMBER (Include area code) (937) 255-6565, ext 7469; e-mail: Raymond.Hill@afit.edu