

CHARACTERIZATION OF NOISE PROPERTIES IN PHOTODETECTORS: A STEP TOWARD ULTRA-LOW PHASE NOISE MICROWAVES¹

J. Taylor,^{*+} F. Quinlan⁺, and S. Diddams⁺

^{*}University of Colorado Physics Dept.

390 UCB, University of Colorado, Boulder, CO 80309, USA

⁺National Institute of Standards and Technology

325 Broadway, Boulder, CO 80305, USA

Abstract

Very-low-noise microwave signals are desirable for many state-of-the-art applications, including many types of radar and imaging systems. However, even state-of-the-art rf oscillator technology for producing signals into the tens of gigahertz range does not generate signals with low enough phase noise for these important systems to work to their full potential. A new approach for achieving microwave signals with ultra-low phase noise involves using an optical frequency divider that has as its reference a narrow-linewidth CW laser. Femtosecond laser frequency combs provide an effective and efficient way to take an ultra-stable optical frequency reference and divide the signal down into the microwave region. In order to convert optical pulses into a usable rf signal, one must use high-speed photodetection; unfortunately, excess phase noise from both technical and fundamental sources can arise in the photodetection process. In order to ultimately minimize the noise effects of the photodetector, we must first characterize some of the known sources for noise arising in these devices. In this paper, we will study two sources of excess noise in high-speed photodiodes—power-to-phase conversion and shot noise. The noise performance of each device will give us clues as to the nature of the sources, their effect on the output signal, and what design features of the photodiode minimize these noise effects.

I. INTRODUCTION

Many technologies like radar and imaging systems require very-low-noise microwave signals in order to push the limits of their performance. However, even state-of-the-art rf oscillator technology is not capable of performing at the low noise levels required to reach these new requirements. Researchers have recently begun to look to optical sources such as high-finesse optical cavities as a means for generating ultra-stable signals. A self-referenced femtosecond laser frequency comb stabilized to one of these cavities functions as an optical-to-microwave frequency divider that transfers the low phase noise properties of a narrow linewidth continuous wave (CW) laser to the repetition rate of the femtosecond laser, producing a very low phase noise source in the tens of gigahertz range sufficient

¹ Contribution of the U.S. government, not subject to copyright.

Report Documentation Page

Form Approved
OMB No. 0704-0188

Public reporting burden for the collection of information is estimated to average 1 hour per response, including the time for reviewing instructions, searching existing data sources, gathering and maintaining the data needed, and completing and reviewing the collection of information. Send comments regarding this burden estimate or any other aspect of this collection of information, including suggestions for reducing this burden, to Washington Headquarters Services, Directorate for Information Operations and Reports, 1215 Jefferson Davis Highway, Suite 1204, Arlington VA 22202-4302. Respondents should be aware that notwithstanding any other provision of law, no person shall be subject to a penalty for failing to comply with a collection of information if it does not display a currently valid OMB control number.

| | | | | | |
|--|------------------------------------|---|---|----------------------------------|---------------------------------|
| 1. REPORT DATE NOV 2009 | 2. REPORT TYPE | 3. DATES COVERED 00-00-2009 to 00-00-2009 | | | |
| 4. TITLE AND SUBTITLE Characterization of Noise Properties in Photodetectors: A Step Toward Ultra-Low Phase Noise Microwaves | | 5a. CONTRACT NUMBER | | | |
| | | 5b. GRANT NUMBER | | | |
| | | 5c. PROGRAM ELEMENT NUMBER | | | |
| 6. AUTHOR(S) | | 5d. PROJECT NUMBER | | | |
| | | 5e. TASK NUMBER | | | |
| | | 5f. WORK UNIT NUMBER | | | |
| 7. PERFORMING ORGANIZATION NAME(S) AND ADDRESS(ES) University of Colorado, Physics Dept, Boulder, CO, 80309 | | 8. PERFORMING ORGANIZATION REPORT NUMBER | | | |
| 9. SPONSORING/MONITORING AGENCY NAME(S) AND ADDRESS(ES) | | 10. SPONSOR/MONITOR'S ACRONYM(S) | | | |
| | | 11. SPONSOR/MONITOR'S REPORT NUMBER(S) | | | |
| 12. DISTRIBUTION/AVAILABILITY STATEMENT Approved for public release; distribution unlimited | | | | | |
| 13. SUPPLEMENTARY NOTES 41st Annual Precise Time and Time Interval (PTTI) Systems and Applications Meeting, 16-19 Nov 2009, Santa Ana Pueblo, NM | | | | | |
| 14. ABSTRACT see report | | | | | |
| 15. SUBJECT TERMS | | | | | |
| 16. SECURITY CLASSIFICATION OF: | | | 17. LIMITATION OF ABSTRACT Same as Report (SAR) | 18. NUMBER OF PAGES 10 | 19a. NAME OF RESPONSIBLE PERSON |
| a. REPORT unclassified | b. ABSTRACT unclassified | c. THIS PAGE unclassified | | | |

for these new applications (Figure 1) [1,2].

Photodetection of the optical pulse train generated from the comb results in a corresponding train of current pulses, which in turn provides a comb of microwave frequencies at the laser repetition rate and its harmonics. In this way, we have previously demonstrated the generation of a 10 GHz microwave signal having fractional frequency instability of no more than 3×10^{-15} in 1 s averaging [1]. The residual phase noise in the optical-to-microwave division can be as low as $L(f) = -110$ dBc/Hz for an offset frequency of 1 Hz, reaching a shot-noise-limited noise floor of $L(f) = -158$ dBc/Hz for $f > 100$ kHz. Integrating the phase noise results in sub-femtosecond residual timing jitter [2].

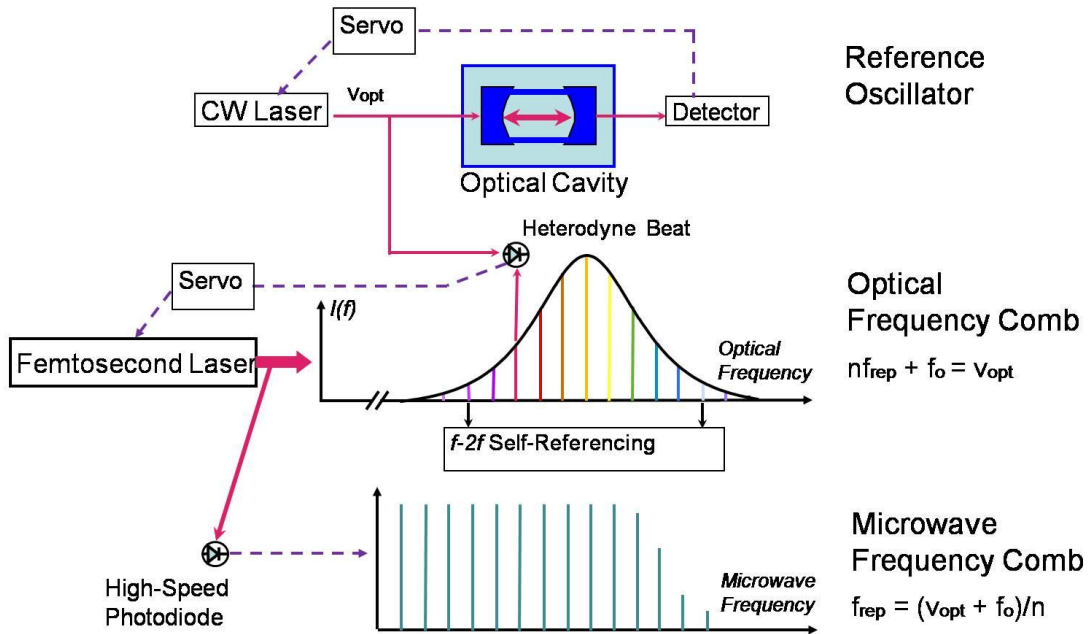

Figure 1. Basic diagram of optical-to-microwave frequency division.

With such low noise levels, any additional noise contributions from components in the system can have a significant effect on overall timing precision. In this paper, we focus on some of the limitations unique to the optical-to-microwave conversion in the photodetection of the optical pulse train. In particular, we study the saturation properties of high-speed (greater than 10 GHz) photodiodes (PDs) and the impact of the saturation on (1) the achievable signal size which, when combined with the detector shot noise, provides the fundamental white noise floor, and (2) the conversion of laser amplitude noise to phase or timing jitter noise (AM-to-PM conversion).

II. PHOTODIODES AND LASER SOURCE

For this study, we survey the performance of four high-speed (greater than 10 GHz) photodetectors in the spectral region around 900 nm of our stabilized, 1 GHz repetition rate mode-locked Ti:Sapph laser used for microwave generation [1,2]. Using a nonlinear autocorrelator, we measure the pulse length at the end of a ~ 1 m SMF pigtail to be ~ 1 ps, and we assume that pulses of approximately this

duration illuminate the photodiodes. Up to 25 mW can be coupled into the PD pigtailed, and the average power is controlled by a variable neutral density filter.

The first two test photodetectors are externally biased InGaAs P-I-N photodiodes by the same manufacturer. The first, PD1, is a packaged diode coupled to a single-mode-fiber (SMF, $\sim 9 \mu\text{m}$ core) pigtail. All measurements are taken at the manufacturer's recommend maximum bias of 7 V. The second photodiode, PD2, is very similar to PD1, but employs an integrated and packaged graded-index (GRIN) lens at the end of its coupling SMF. The GRIN lens shapes the optical beam to produce a more uniform illumination profile (flat-top rather than Gaussian) on the photodiode; this suppresses peak photocurrent density and more effectively illuminates the whole diode [3,4]. This diode can be operated up to a peak bias voltage of 9 V; unless otherwise noted, all measurements are taken at this bias value. In this spectral regime, the responsivity of these two photodiodes is 0.3 mA/mW (PD1) and 0.26 mA/mW (PD2), respectively.

Test diode three, PD3, is a packaged InGaAs Schottky detector. A 9 V bias is maintained by a battery within the detector housing. At 900 nm, responsivity is measured to be 0.37 mA/mW. In the past in our lab, similar units experienced device failure at higher optical powers, so for these tests the incident optical power was kept under 7 mW as a precaution. The fourth test photodiode, PD4, is a packaged GaAs PIN detector with an SMF pigtail and an internal battery bias of 6 V. Responsivity is a measured 0.12 mA/mW at 900 nm. All four diodes are terminated at 50 Ω .

III. SHOT NOISE FLOOR

Photodiodes work by converting incoming photons into an outgoing electrical current within the semiconductor media. There are intrinsic amplitude and phase fluctuations of the electrical current that arise from two fundamental phenomena: thermal noise and shot noise. Thermal (Johnson, resistive) noise is associated with random fluctuations of the current across resistive elements of the photodetection circuit (e.g., the load resistor of the photodiode). Shot noise is related to the randomness of the incident photon stream [5,6]. In a typical high-speed detection system with a 50 Ω termination, the shot noise dominates the thermal noise for photocurrents greater than approximately 0.5 mA (see Figure 3). It is this regime that we consider in this paper.

The rms shot noise current in a single quadrature (e.g., phase quadrature) is given by

$$i_{shot} = \sqrt{e i_{avg} BW} ,$$

where BW is the measurement resolution bandwidth (henceforth assumed to be 1 Hz), e is the elementary charge (1.6×10^{-19} C), and i_{avg} is the average photocurrent created by the incident optical power [5]. The shot noise power, P_{shot} , is related to the shot noise current by

$$P_{shot} = i_{shot}^2 R = e i_{avg} R ,$$

where R is the load resistor of the PD, typically 50 Ω (Figure 3(a)). The thermal noise power at room temperature is shown for comparison as the dashed line in Figure 3(b). The spectrally white shot noise will be the fundamental noise floor in the detection of the microwave signals we are ultimately interested in. Relative to the power in the signal, it can be expressed in terms of $S_{\phi}^{shot}(f)$, the PSD of phase fluctuations in a 1 Hz bandwidth; this is the ratio of the shot noise power to the microwave

carrier power, P_{rf} . Noise is most commonly described logarithmically by the single-sideband noise, $L(f)$, which is related to $S(f)$ by the following expression [7]:

$$L(f) = 10 \log\left[\frac{1}{2} S(f)\right].$$

Then our final expression for shot-noise-limited noise floor is given by

$$L_{\phi}^{shot} = 10 \log\left[\frac{ei_{avg}R}{P_{rf}}\right].$$

To determine the shot noise floor for the desired 10 GHz signal, we measured the output of each PD on a microwave spectrum analyzer and on a voltmeter using a bias tee (see Figure 2). From the dc voltage reading, we can calculate average photocurrent simply using $i_{avg} = V/R$, where $R=50 \Omega$. P_{rf} at 10 GHz is measured in units of dBm directly from the spectrum analyzer and is proportional to i_{avg}^2 .

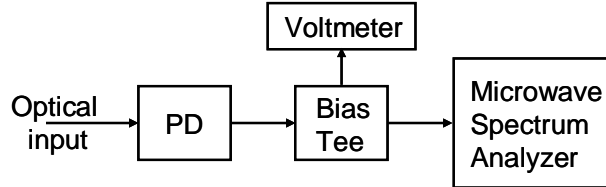

Figure 2. Schematic of shot noise measurement.

Shot noise, L_{ϕ}^{shot} , one part of the total noise performance, as a function of average photocurrent was calculated from measured photocurrent for each photodiode and plotted in Figure 3(c). It does not include noise contributions from any other source, including thermal noise. The shot noise floor for each PD varies slightly because each has different responsivity, resulting in different signal sizes at 10 GHz, so noise level isn't directly comparable among the four [7]. If we measured the total noise of the photodetectors, their noise plots would be limited by the thermal noise floor (dashed line in Figure 3(c)) until the point at which the shot noise exceeds the thermal noise, roughly 0.4 mA for a PD with responsivity of 0.3 mA/mW. PD1 begins to saturate heavily in this region, and we see L_{ϕ}^{shot} increase as the photocurrent is increased. This is because the 10 GHz signal power decreases under saturation, while the shot noise power continues to increase. PD3 and PD4 remain linear to about 1 mA; PD4 appears to saturate a bit faster than PD3. PD2 remains nearly linear up to ~3 mA, resulting in a 10 dB improvement of the noise floor over PD1.

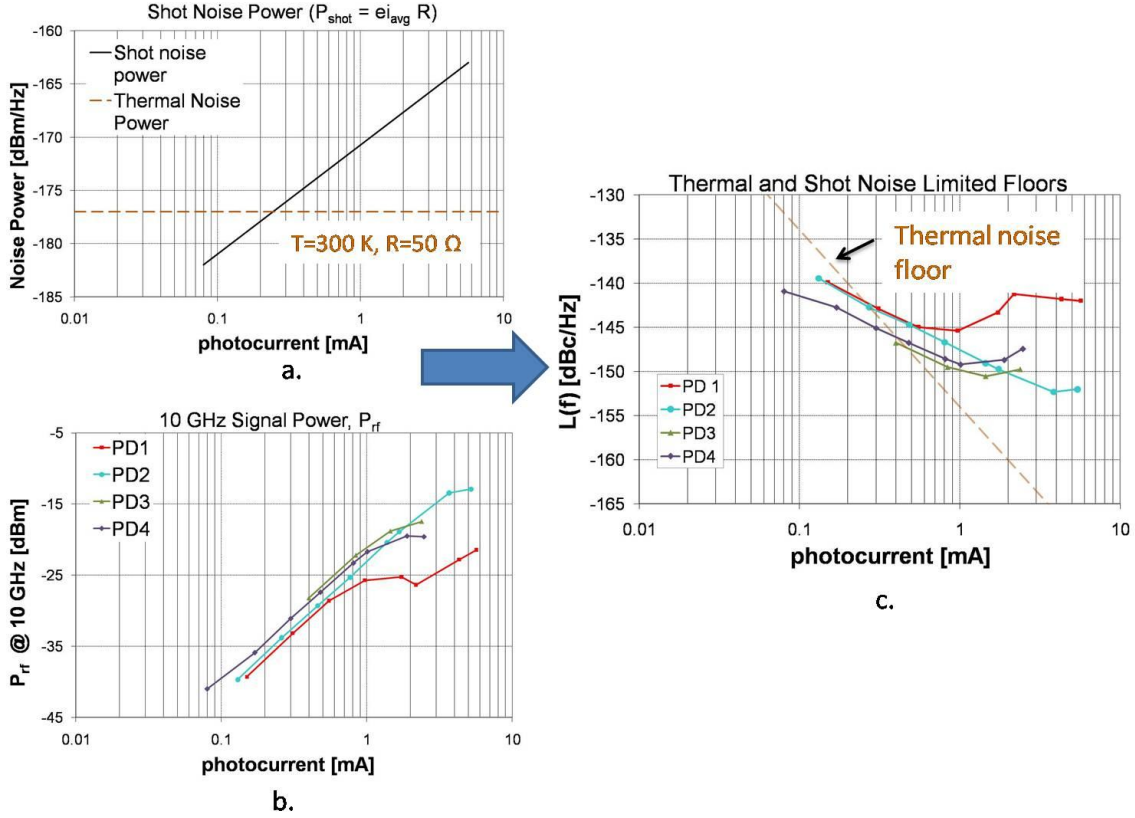

Figure 3. (a) Shot and thermal noise power levels. (b) Signal power for the 10 GHz tone from laser pulse. (c) Shot noise, L_{ϕ}^{shot} , of the four test diodes calculated from average photocurrent, i_{avg} . The thermal noise floor is noted for reference; when measuring all noise, photodiode performance would follow this limit (not fall below it) until the point when the two functions cross. Then shot noise dominates over thermal noise until saturation.

While all photodiodes differ in intrinsic characteristics and behaviors at different frequencies, these data illustrate that, due to the power dependence of both thermal and shot noise, high power handling in the photodiode is an important criterion for minimizing these effects in the resulting signal.

IV. POWER-TO-PHASE CONVERSION

While operating at higher power might improve the shot noise floor, another power-dependent effect, power-to-phase fluctuation, is observed to adversely affect the transition from optical to microwave within the photodiode [7-10]. Broadening of a PD's electrical pulse (phase fluctuation) is observed when the incident optical power is increased (amplitude fluctuation), as shown in Figure 4. This means that there is a delay in the transmission of photocarriers generated by the incident pulse train across the photodiode. If more photocarriers are generated when the optical power is increased, then interactions between them generate internal electric fields opposing the bias field of the diode, increasing the transit time of a photocarrier and resulting in a broadening of the output pulse [11-13]. Ultimately, this affects the overall phase noise of the generated microwave signal. Increasing the bias

voltage is one way of improving power-to-phase fluctuations; however, device failure due to runaway of dark current occurs due to a bias voltage that gets too large (see Section II) [4,14].

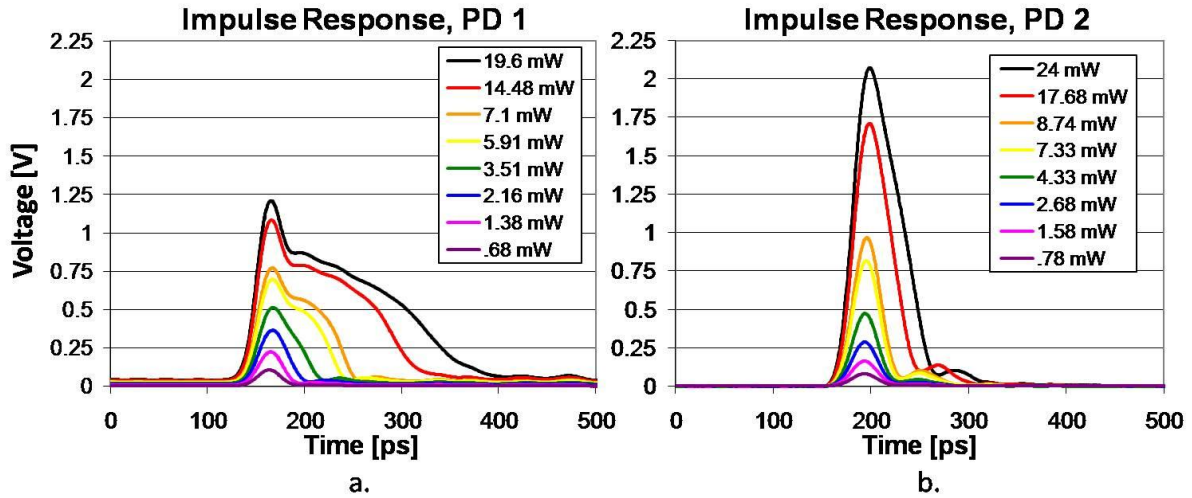

Figure 4. Impulse response of PD1 (a) and PD2 (b) measured with a 20 GHz sampling oscilloscope. As optical power increases, PD1's pulse broadens significantly more than PD2's.

This effect can also be seen by plotting the full width at half max (FWHM) of the pulse with respect to changing incident optical power, as in Figure 5(a). PD1 and PD3 exhibit faster broadening than PD2 and PD4. Due to the power limitations on PD3, it is unknown how this trend continues at higher optical powers.

Two different ways of quantifying this effect in photodiodes are described below. The first method extracts phase information from the electrical impulse response, as measured with a 20 GHz sampling oscilloscope, using Fourier transform analysis, which can be performed by many widely available computer programs [15]. Taking the FFT of the impulse response provides the RF phase in radians. A cubic polynomial is fitted to a plot of RF phase vs. optical power, and the power-to-phase conversion (PPC) factor, $\frac{d\phi}{dP}$, at a given optical power is the slope of the fitted line with respect to average optical power at that point.

Figure 5(b) shows PPC factor as a function of optical power for PD1, PD2, and PD4. PD3 was not included in this analysis. PD1 exhibits high power-to-phase conversion, while PPC for PD2 and PD4 is lower.

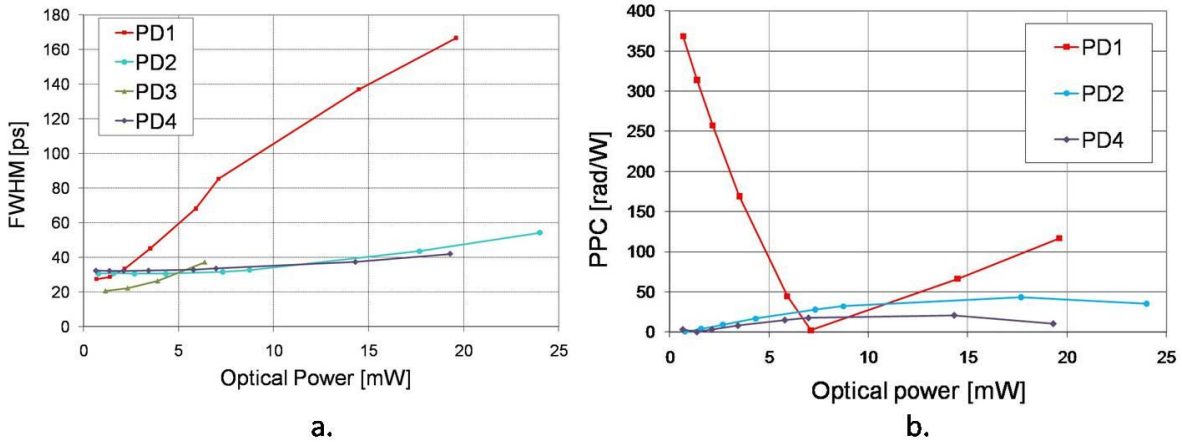

Figure 5. (a) FWHM as a function of optical power for the four test diodes. (b) Power-to-phase conversion factor from FFT analysis.

We can also make a direct phase measurement using a microwave “phase bridge.” This method, shown in Figure 6, uses an acousto-optic modulator (AOM) to insert a constant 20 kHz modulation of about 1 % modulation depth on the light source while also stepping the optical power into the PD using a neutral density (ND) filter wheel. An rf mixer detects phase shifts due to power changes, and the output voltage is converted to radians using the mixer gain factor, k_d [V/rad]. Since k_d changes with signal power, we include a variable attenuator and amplifier combination in front of the mixer to compensate for changing optical power at the PD. Another 30 kHz amplitude modulation is placed on the test arm. This tone is monitored on the FFT analyzer and is minimized using the phase shifter. This sets quadrature at the mixer, allowing only phase modulation (PM) through to the mixer output.

The spectral power of the initial 20 kHz amplitude modulation is measured on the FFT analyzer from the output of the bias tee and then divided by the optical power to find the normalized power of the input signal. The height of the 20 kHz tone from the output of the mixer (which only contains any phase modulation from AM-to-PM conversion in the PD) is then measured on the FFT analyzer and converted to radians as described above. The ratio of the two gives us the power-to-phase conversion for this method.

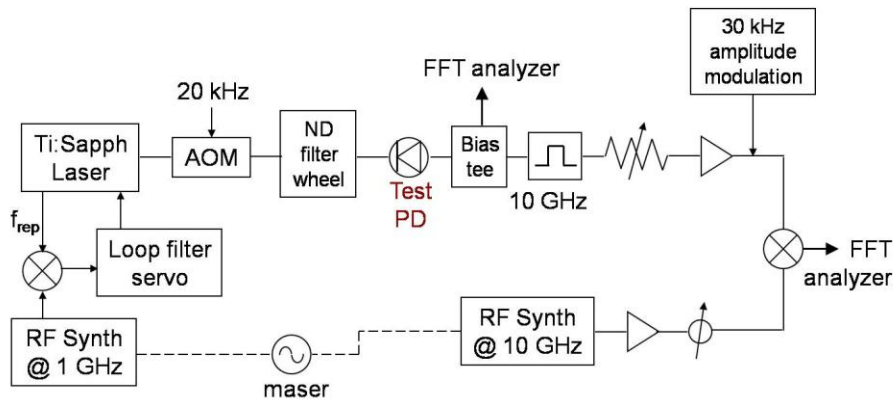

Figure 6. Phase bridge setup for AM-to-PM conversion measurement.

It should be noted that, in the measurement using the sampling oscilloscope, power is changed only by using the filter wheel; there is no higher frequency fluctuation on the beam as in the phase bridge method. Due to this as well as the use of the normalized power of the input signal in the phase bridge, the power-to-phase conversion factor for these two methods cannot be directly compared, but general trends can be seen between the two methods.

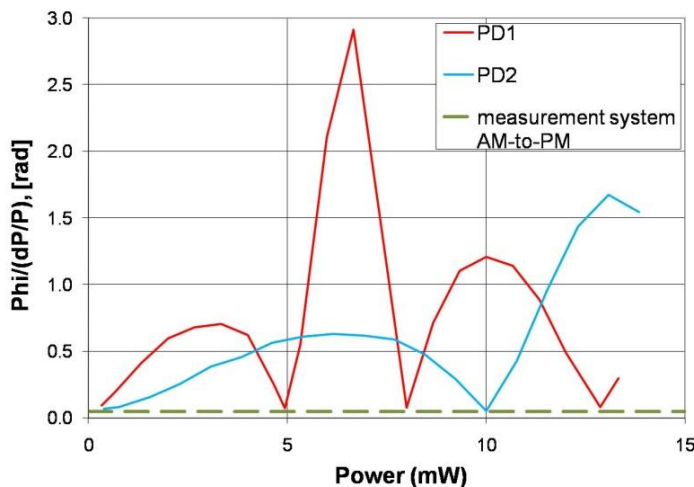

Figure 7. Results of phase bridge measurement with PD1 and PD2.

This phase bridge measurement was done for PD1 and PD2, both at a bias voltage of 7 V; Figure 7 shows the results. In general, PD2 shows less conversion from power to phase as the optical power changes, with some increased effect at higher power. However, both photodiodes have null points where the AM-to-PM conversion drops almost to zero. These nulls and related peaks have been observed by others as well [10], yet the reason for this effect is not well understood. In theory, one would like to set the optical power to one of these nulls and operate; however, these points were observed to fluctuate from one measurement to the next. This is possibly due to changes in temperature, bias voltage, or other parameters that haven't yet been considered. Nevertheless, if operation at a null is not a consistent option, it is possible to achieve across-the-board reduction in power-to-phase conversion by using a photodiode, such as PD2, that is less sensitive over a wide range of optical powers.

The system AM-to-PM floor was also measured to see if amplitude modulation was converted to phase modulation in any of the rf components, such as the amplifiers. The measurement was repeated with a 10 GHz synthesizer in place of the laser source. The dashed green line in Figure 7 shows that any AM-to-PM conversion in the system itself is well below the effects we see when the photodiodes are included in the setup.

V. CONCLUSION

We have discussed the limitations of shot noise and power-to-phase conversion in photodiodes. As shown by the photodiodes tested here, the effect of these noise phenomena can vary depending on the diode used in the measurement system. Here, we tested these diodes in the 900 nm spectral range; however, some diodes are optimized to work in the telecomm regimes of 1310 nm or 1550 nm. The

SMF pigtailed may also be multimode in this region, causing some losses as well. Some diodes can handle higher bias voltages, and others can operate at higher optical powers. State-of-the-art advances in manufacturing are producing diodes that are generally less sensitive to these effects. In the end, one should be able to choose a diode that exhibits the best performance in the specific application, in this case, the generation of ultra-low microwave signals.

ACKNOWLEDGMENTS

The authors thank Archita Hati and Craig Nelson for their contributions to this project and Dave Howe for support of this project. We also thank Shubhashish Datta and Abhay Joshi for valuable discussions and providing some of the photodiodes used in this work. This work was sponsored by the National Security Agency and supported by NIST.

REFERENCES

- [1] A. Bartels, S. A. Diddams, C. W. Oates, G. Wilpers, J. C. Bergquist, W. H. Oskay, and L. Hollberg, 2005, "*Femtosecond-laser-based synthesis of ultrastable microwave signals from optical frequency references*," **Optics Letters**, **30**, 667-669.
- [2] J. J. McFerran, E. N. Ivanov, A. Bartels, G. Wilpers, C. W. Oates, S. A. Diddams, and L. Hollberg, 2006, "*Low-noise synthesis of microwave signals from an optical source*," **Electronics Letters**, **41**, 36-37.
- [3] A. Joshi and D. Becker, 2007, "*GRIN lens-couple top-illuminated photodetectors for high-power applications*," in Proceedings of the International Topical Meeting on Microwave Photonics, 3-5 October 2007, Victoria, British Columbia, Canada, Paper W-1.5.
- [4] A. Joshi, S. Datta, and D. Becker, 2008, "*GRIN Lens Coupled Top-Illuminated Highly Linear InGaAs Photodiodes*," **IEEE Photonics Technology Letters**, **20**, 1500-1502.
- [5] A. Yariv, 1991, **Optical Electronics** (4th ed.; Saunders College Publishing, Philadelphia), pp. 364-372.
- [6] B. E. A. Saleh and M. C. Teich, 1991, **Fundamentals of Photonics** (John Wiley & Sons, New York), pp. 676-677.
- [7] S. Foreman, K. Holman, D. Hudson, D. Johnes, and J. Ye, 2007, "*Remote transfer of ultrastable frequency references via fiber networks*," **Review of Scientific Instruments**, **78**, 021101.
- [8] Characterization of Clocks and Oscillators: NIST Technical Note 1337 (D. Sullivan, D. Allan, D. Howe, and F. Walls, ed.; U.S. GPO, Washington, DC, 1990), pp. 19-25.
- [9] E. Ivanov, S. Diddams, and L. Hollberg, 2003, "*Analysis of Noise Mechanisms Limiting Frequency Stability of Microwave Signals*," **IEEE Journal of Selected Topics in Quantum Electronics**, **9**, 1059-1065.

- [10] E. Ivanov, S. Diddams, and L. Hollberg, 2005, “*Study of the Excess Noise Associated with Demodulation of Ultra-Short Infrared Pulses,*” **IEEE Transactions on Ultrasonics, Ferroelectrics, and Frequency Control**, **UFFC-52**, 1068-1074.
- [11] K. Williams and R. Esman, 1992, “*Observation of Photodetector Nonlinearities,*” **Electronics Letters**, **28**, 731-732.
- [12] D. Tulchinsky and K. Williams, 2004, “*Phase noise in compressed photodiodes,*” in Technical Digest of the IEEE International Topical Meeting on Microwave Photonics, 4-6 October 2004, Ogunquit, Maine, Paper WA-6, pp. 269-272.
- [13] M. Currie and I. Vurgaftman, 2006, “*Microwave Phase Retardation in Saturated InGaAs Photodetectors,*” **IEEE Photonics Technology Letters**, **18**, 1433-1435.
- [14] K. Williams, R. Esman, and M. Dagenais, 1996, “*Nonlinearities in p-i-n microwave photodetectors,*” **Journal of Lightwave Technology**, **14**, 84-96.
- [15] A. Joshi and S. Datta, 2009, “*Dual InGaAs Photodiodes Having High Phase Linearity for Precise Timing Applications,*” **IEEE Photonics Technology Letters**, **21**, 1360-1362.