

A Prognostic Development Methodology with Demonstration Examples

**DARPA/DSO Prognosis Bidder's Conference
September 26-27, 2002
Alexandria, VA**

**Bill Hardman
hardmanwj@navair.navy.mil
Propulsion and Power
Naval Air Systems Command**

26 September, 2002

Report Documentation Page

Form Approved
OMB No. 0704-0188

Public reporting burden for the collection of information is estimated to average 1 hour per response, including the time for reviewing instructions, searching existing data sources, gathering and maintaining the data needed, and completing and reviewing the collection of information. Send comments regarding this burden estimate or any other aspect of this collection of information, including suggestions for reducing this burden, to Washington Headquarters Services, Directorate for Information Operations and Reports, 1215 Jefferson Davis Highway, Suite 1204, Arlington VA 22202-4302. Respondents should be aware that notwithstanding any other provision of law, no person shall be subject to a penalty for failing to comply with a collection of information if it does not display a currently valid OMB control number.

1. REPORT DATE 2002		2. REPORT TYPE N/A		3. DATES COVERED -	
4. TITLE AND SUBTITLE A Prognostic Development Methodology with Demonstration Examples				5a. CONTRACT NUMBER	
				5b. GRANT NUMBER	
				5c. PROGRAM ELEMENT NUMBER	
6. AUTHOR(S)				5d. PROJECT NUMBER	
				5e. TASK NUMBER	
				5f. WORK UNIT NUMBER	
7. PERFORMING ORGANIZATION NAME(S) AND ADDRESS(ES) Propulsion and Power Naval Air Systems Command				8. PERFORMING ORGANIZATION REPORT NUMBER	
9. SPONSORING/MONITORING AGENCY NAME(S) AND ADDRESS(ES)				10. SPONSOR/MONITOR'S ACRONYM(S)	
				11. SPONSOR/MONITOR'S REPORT NUMBER(S)	
12. DISTRIBUTION/AVAILABILITY STATEMENT Approved for public release, distribution unlimited					
13. SUPPLEMENTARY NOTES The original document contains color images.					
14. ABSTRACT					
15. SUBJECT TERMS					
16. SECURITY CLASSIFICATION OF:			17. LIMITATION OF ABSTRACT UU	18. NUMBER OF PAGES 27	19a. NAME OF RESPONSIBLE PERSON
a. REPORT unclassified	b. ABSTRACT unclassified	c. THIS PAGE unclassified			

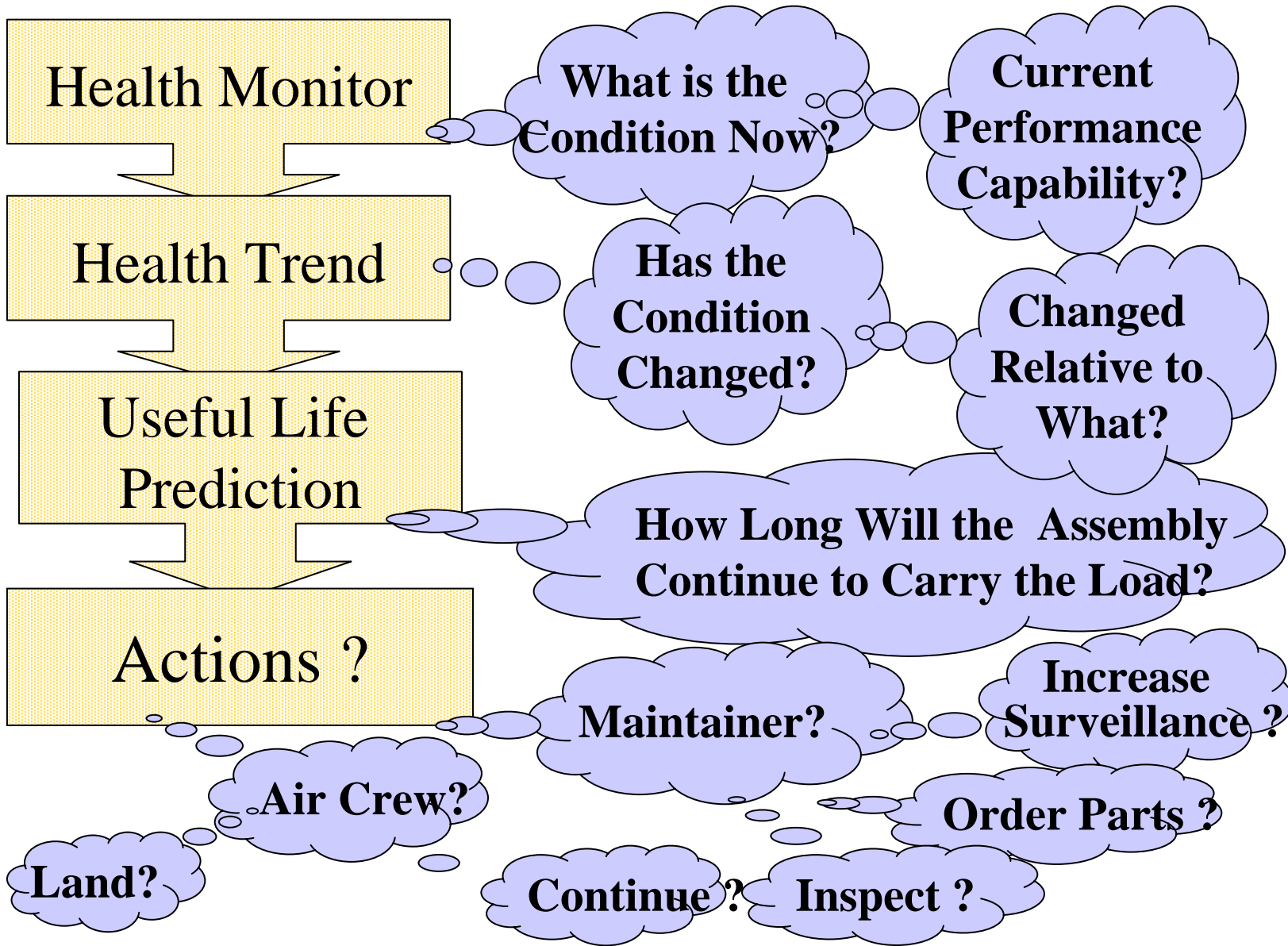

Prognostics

Tool Kit or “Bag of Tricks”

- Accurate/sensitive sensors, algorithms, indicators
- Multiple independent indicators and analysis
- Model based techniques
 - Detailed understanding of the physical system
 - Normal and degraded failure conditions
- Determination of component health at any point in time
- Incorporation of FMECA results
- Impact of secondary component damage
- Techniques for data scatter and false alarms
 - Fuzzy logic, neural networks, AI
 - Data/Information fusion
- Reasoners

Prognostics Integration Tasks

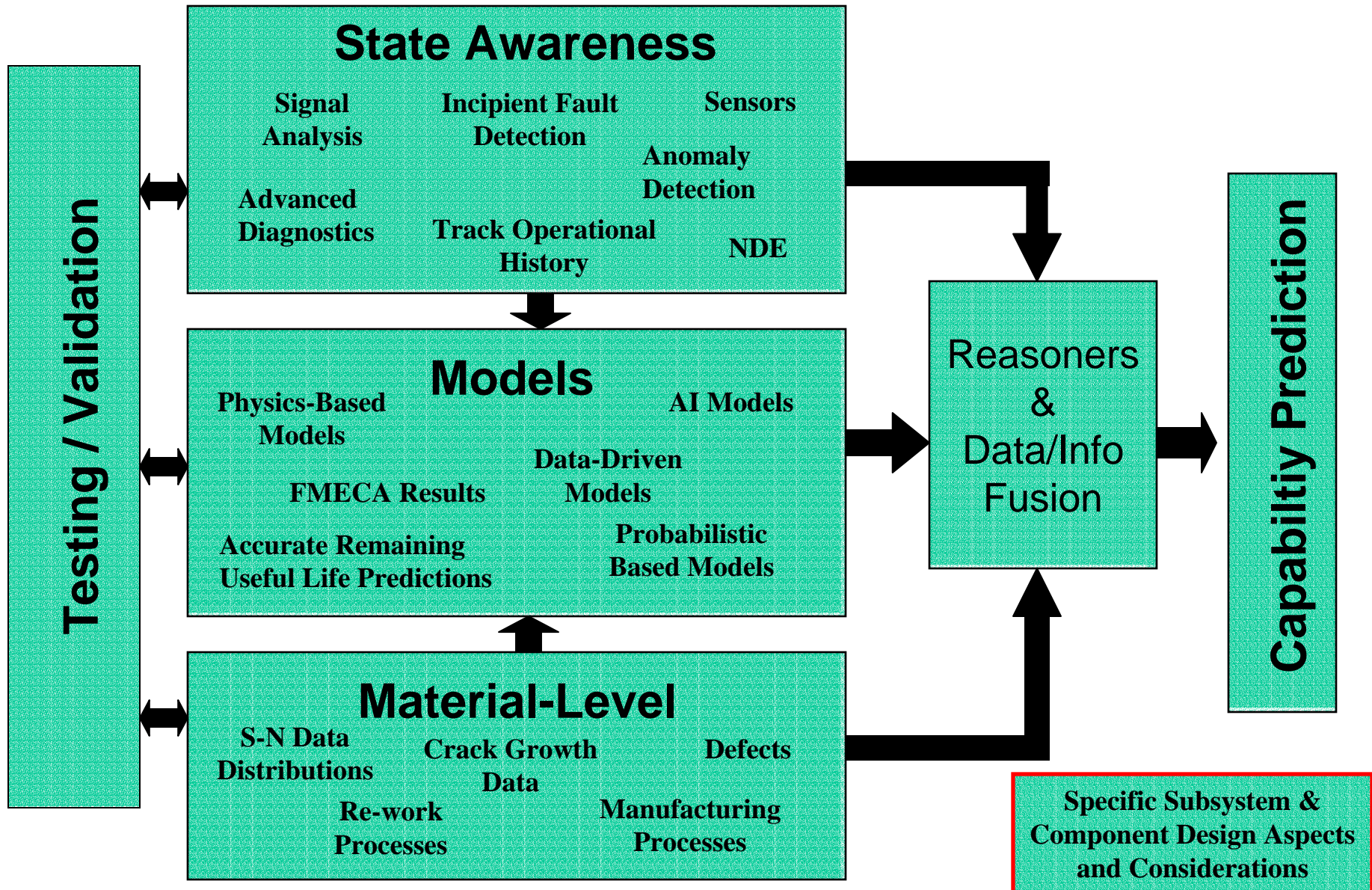

Fault Management Process and Timeline

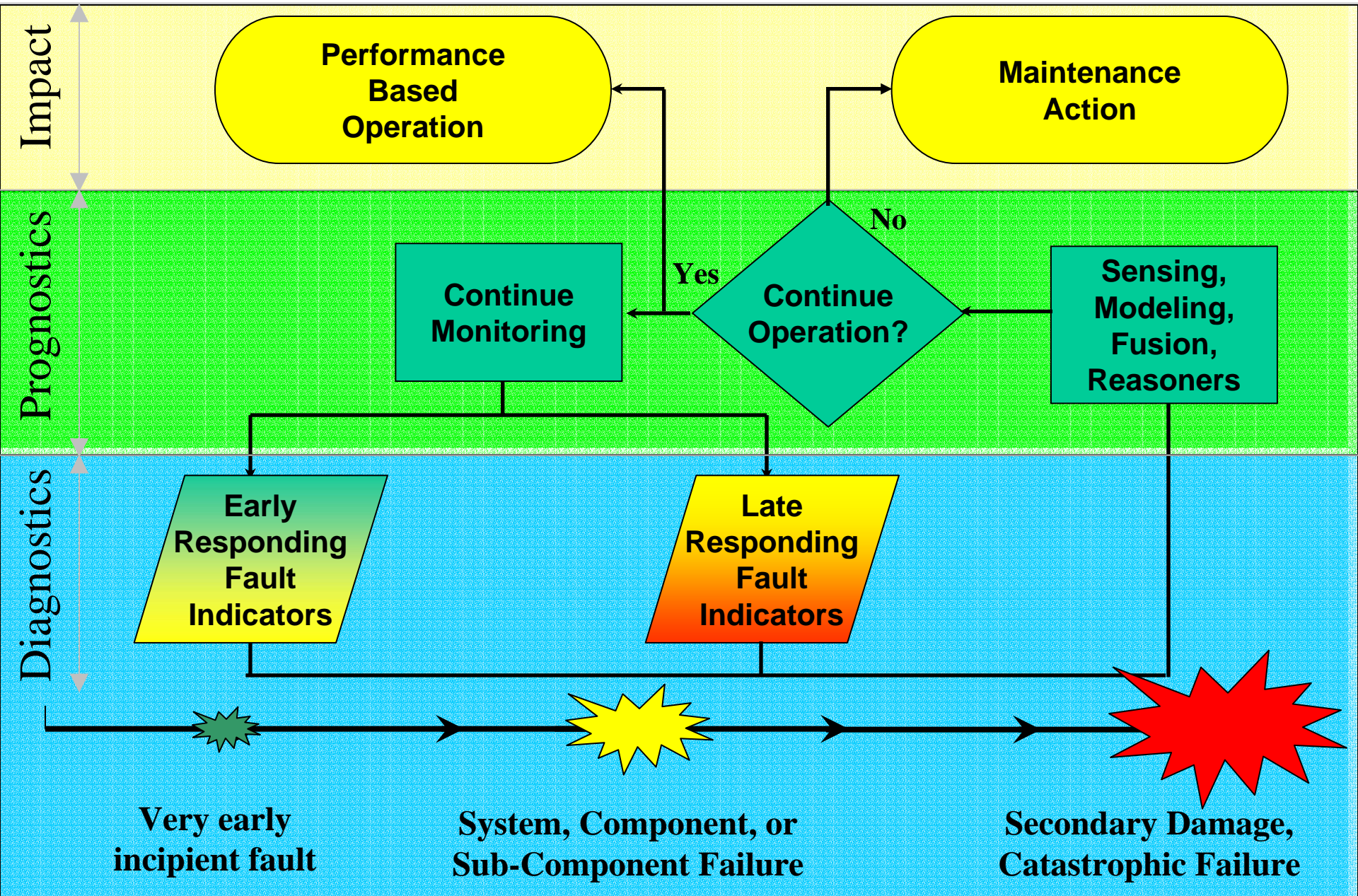

- Using diagnostic algorithms and techniques
- Intelligent setting of alarm thresholds
 - Cockpit and maintenance
- Elimination of false alarms
- Signature deconvolution to extract incipient fault signatures and “see” precursors to component failure
- Extrapolation of diagnostic indicators and statistical data enabling trending and failure predictions
- Need to understand failure progression rates
 - Knowledge base of experienced failures
 - “Seeded fault” data base
 - Accurate models

Notional Strategy to Demo Predictive Prognostics on Helo Drivetrain

1. Identify and Target Components and Sub-elements suitable for Prognostics
 - Those with understandable fault to failure progression characteristics
 - Eliminate those impossible or too hard to consider
2. Develop and/or Obtain advanced models
 - Fault to failure progression characteristics
 - Useful life remaining
3. Perform experimental seeded fault tests
 - As many as affordable/beneficial
 - Try to understand the physics of the failure
4. Verify and validate models
 - Seeded fault and
 - Blind test data
5. Modify useful life remaining prediction model to account for real world considerations
 - Mission Profiles
 - Operational Environment
 - Operational History

PAX River Helicopter Transmission Test Facility

SH-60 Drive System Config:

- Two T700 Engines
- Dual Engine Ops and OEI
- Main Gearbox
- Input Modules
- Accessory Modules
 - Generators
 - Hydraulic Pumps
- Tail Drive System
 - Oil Cooler, IGB, TGB,
Shafting & Rotor Brake

Aircraft Loads Simulated

- Main Rotor Load - 8,000
SHP
- Main Rotor Lift - 50,000 #
- Main Rotor Bending - 5,000 #
- Tail Rotor Load - 700 SHP
- Accessories
- Rotor Brake

“Diagnostics Laboratory”

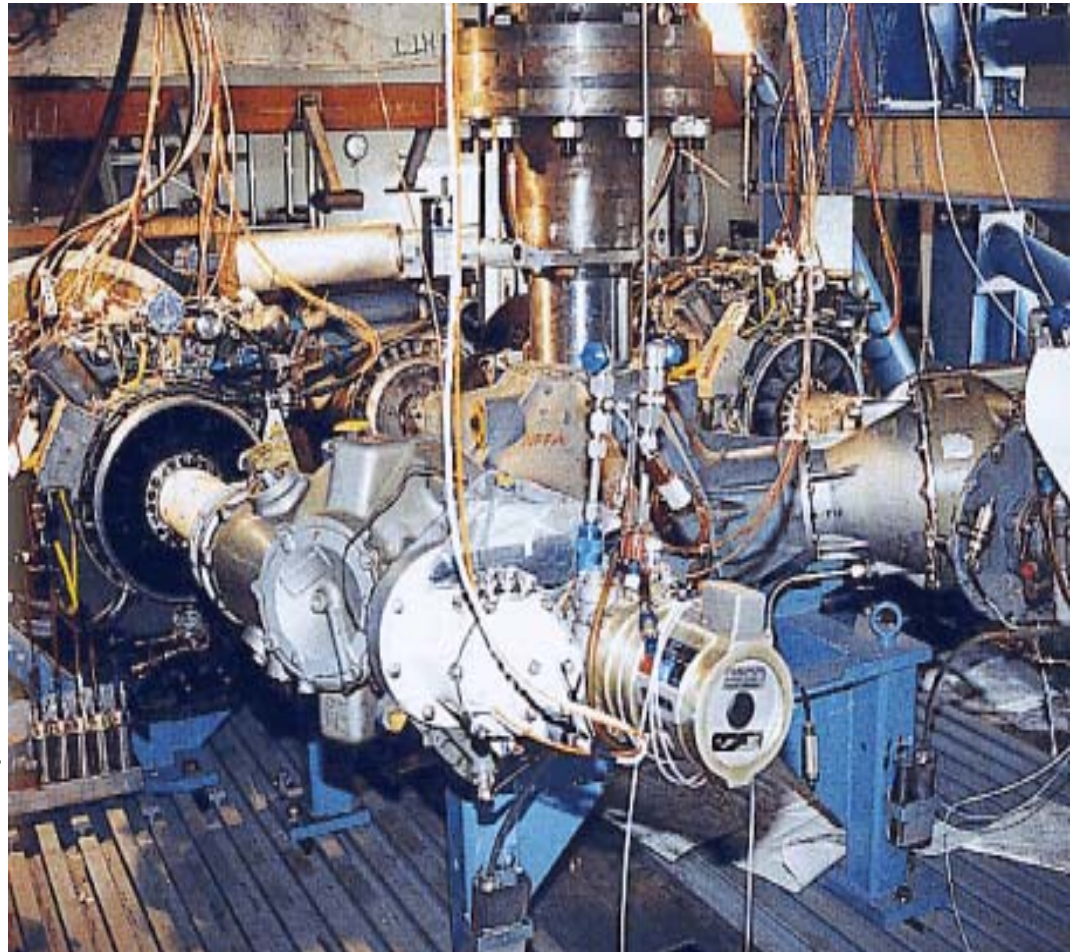

Objective

- Investigate and develop initial recommendations on integral elements for a predictive prognostic development strategy
 - Seeded fault testing
 - Physical and statistical based modeling
 - Finite element analysis
 - Material science and understanding physics of failures
- Establish baseline capability for prediction of system level useful life and performance capabilities

Procedure

- Create stress riser in gear to induce crack
- Run gear at Pax River HTTF until just before catastrophic gearbox failure
- Inspect at regular intervals
- Attempt to:
 - Measure crack size and determine crack propagation rates
 - Predict remaining useful life
 - Obtain better understand the physics of failure for this component



**Fracture site
at Toe of tooth**

EDM Notch (0.25"L x 0.04"D x 0.005"W)

Intermediate Gearbox Pinion Crack Test

Inspections based on hours

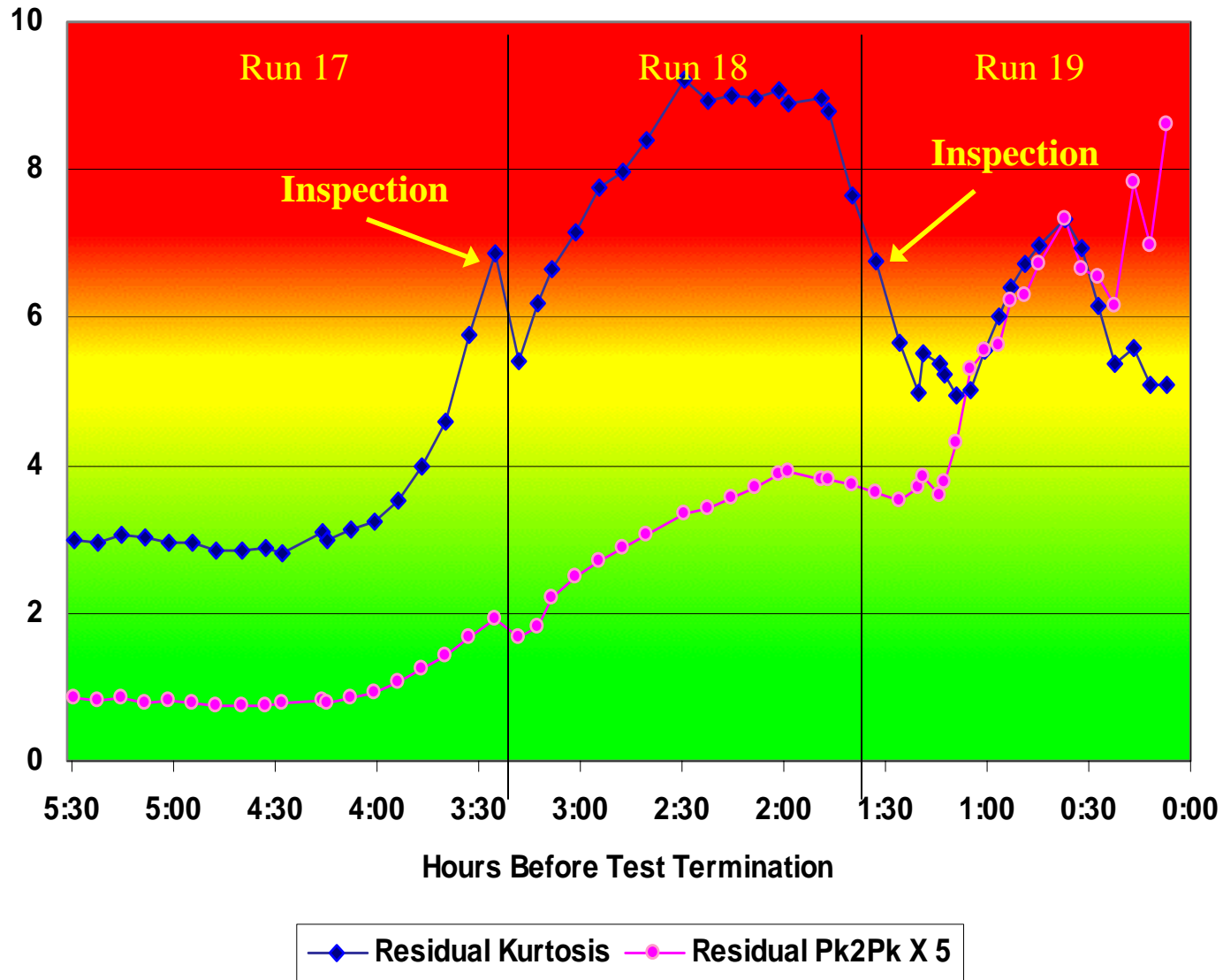

Intermediate Gearbox Pinion Crack Test Inspections Based on Condition Indicators

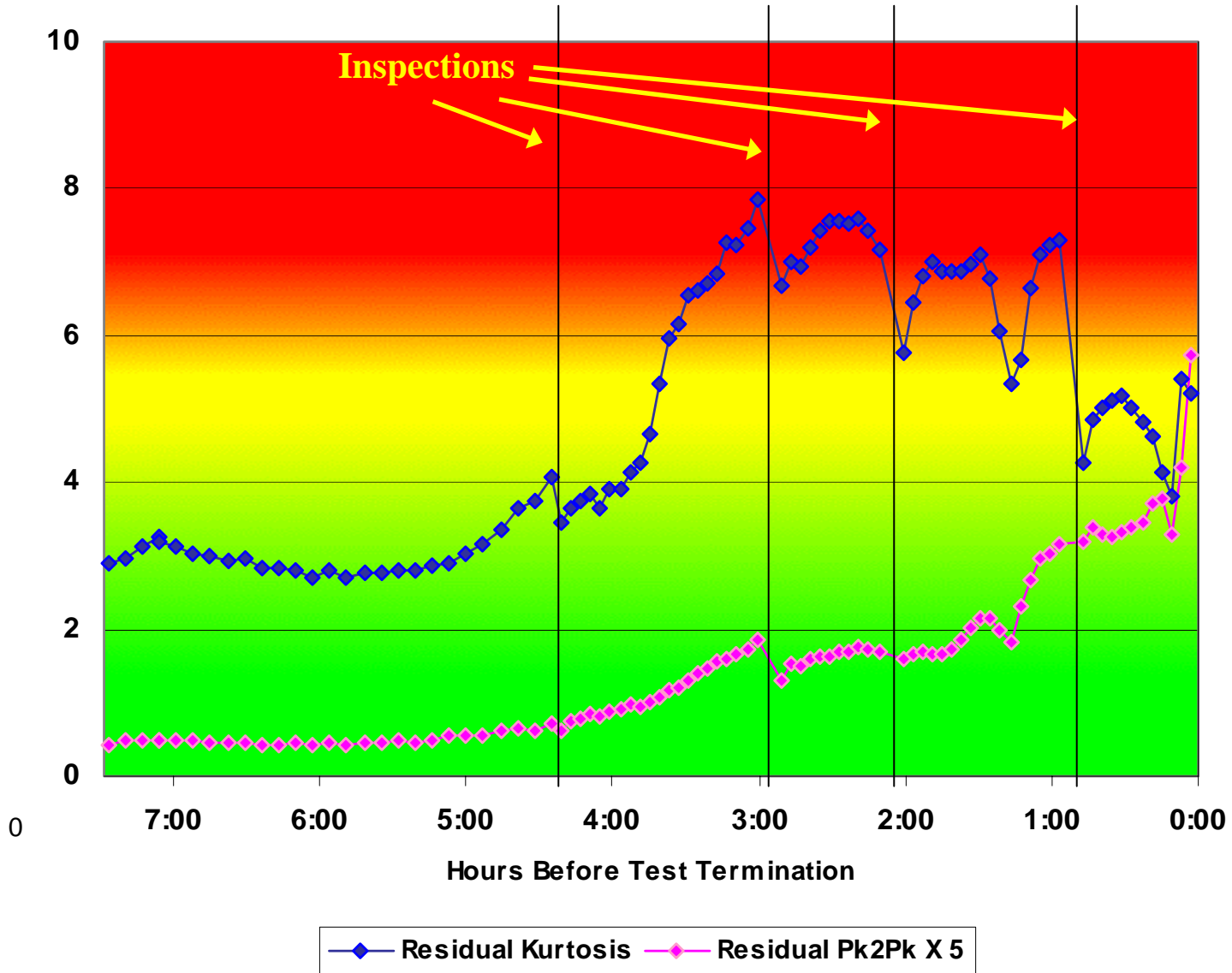

H-60 IGB Pinion Gear Surface Inspection

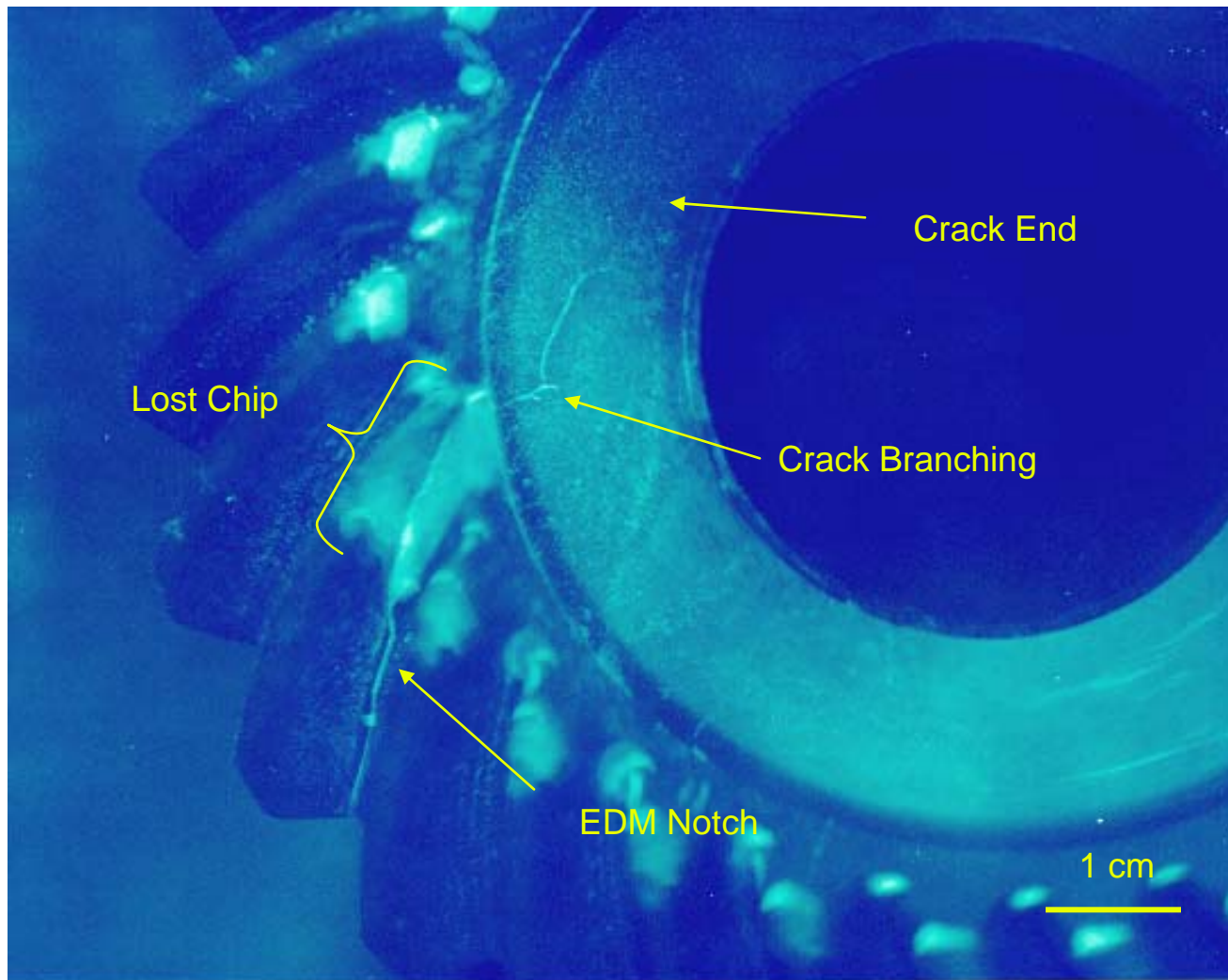

Image of heel notch inner end after Run 15 (first test), showing small chip liberated (arrow). No noticeable change until run 18.

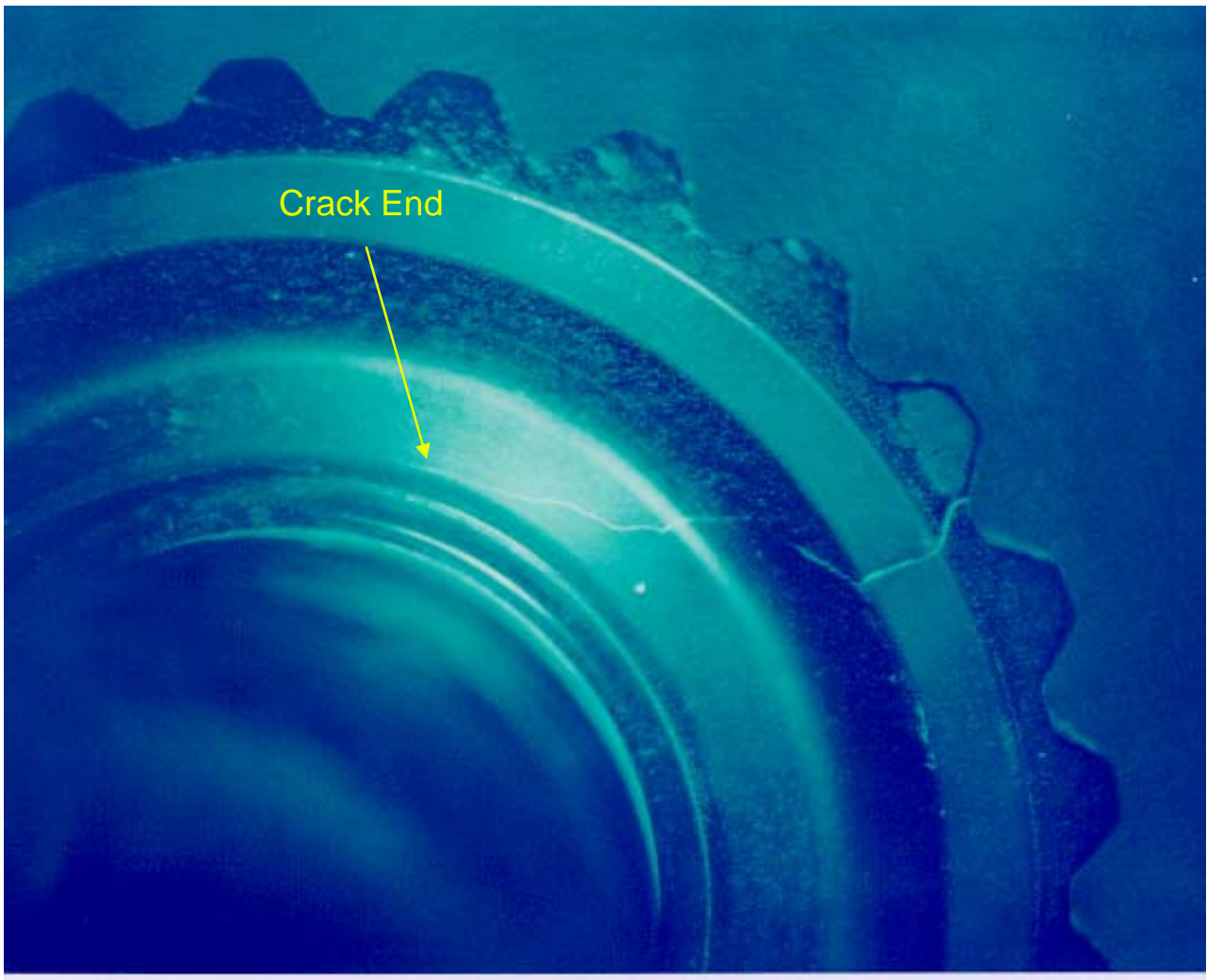

Image of heel notch outer end after Run 18 (first test), showing obviously visible crack (arrow).

H-60 IGB Pinion Gear Mag Particle UV Image



H-60 IGB Pinion Gear Mag Particle UV Image



H-60 IGB Pinion Gear Fracture

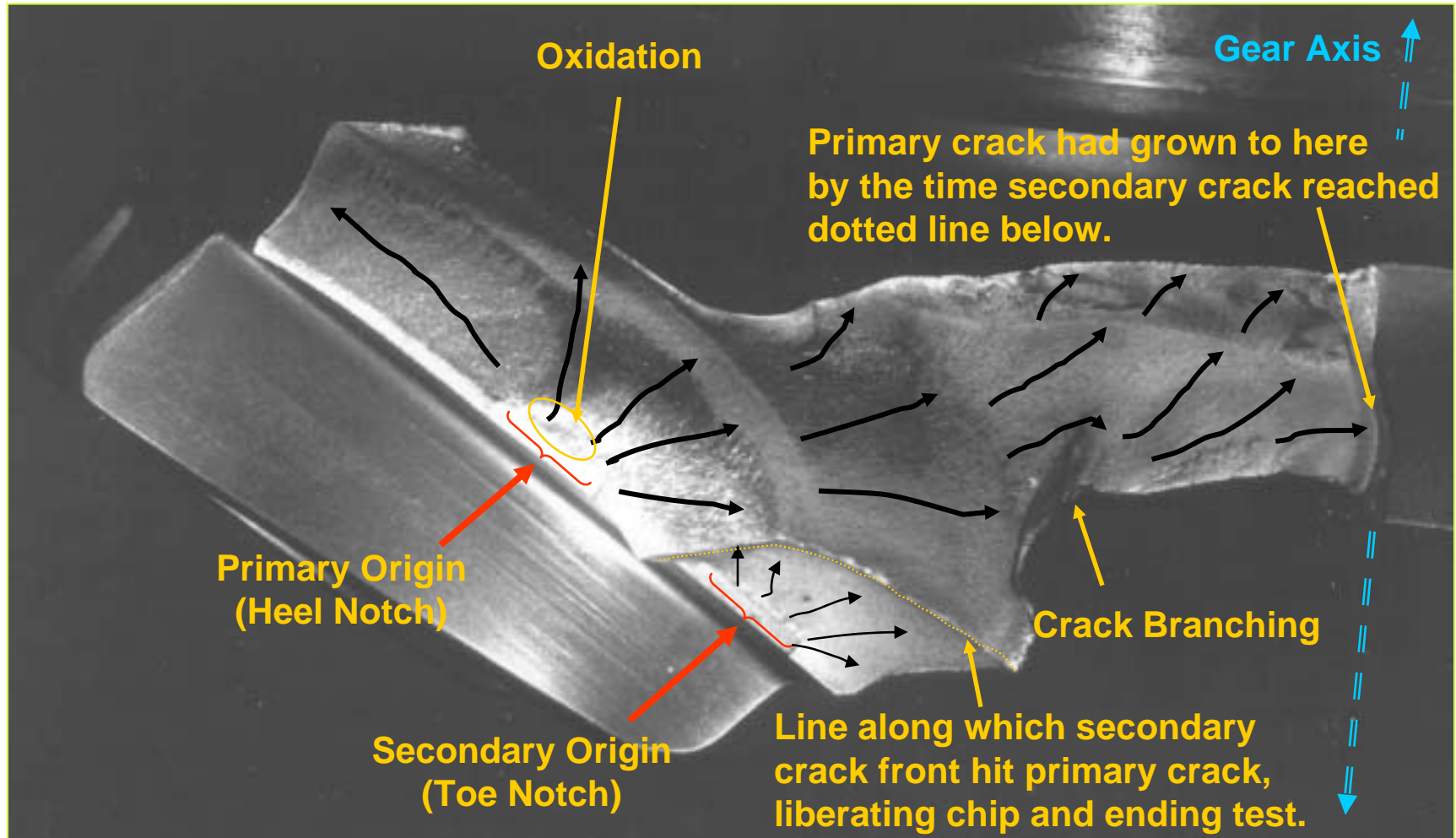

Second test of IGB Pinion

- Test Suspended upon detection of initial vibration indicator response
- Thermosonic imaging shows sub-surface crack
 - Located underneath the heel notch
 - Toe notch shows no damage

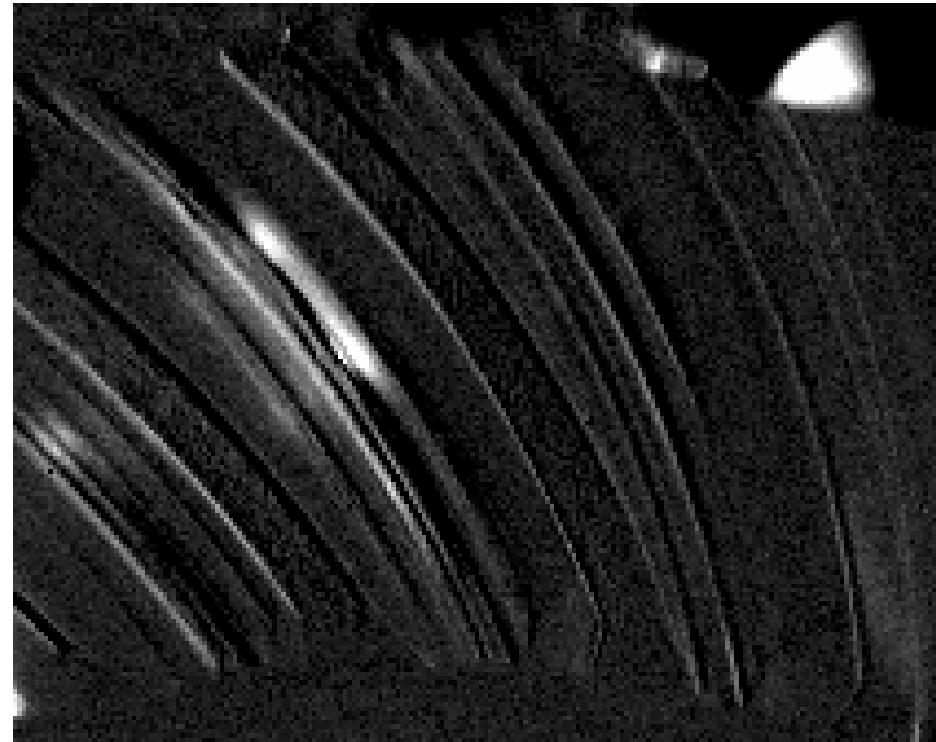
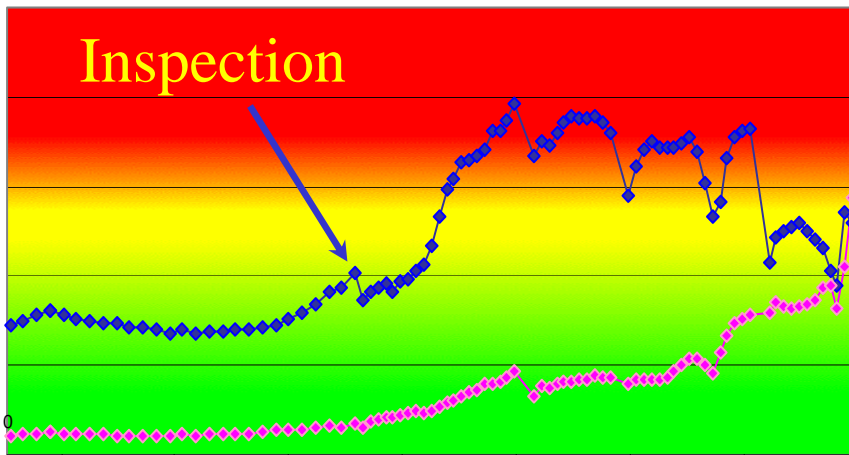

Model of the Failure AERA and Impact SBIRs

Finite Element Mesh for
IGB Pinion

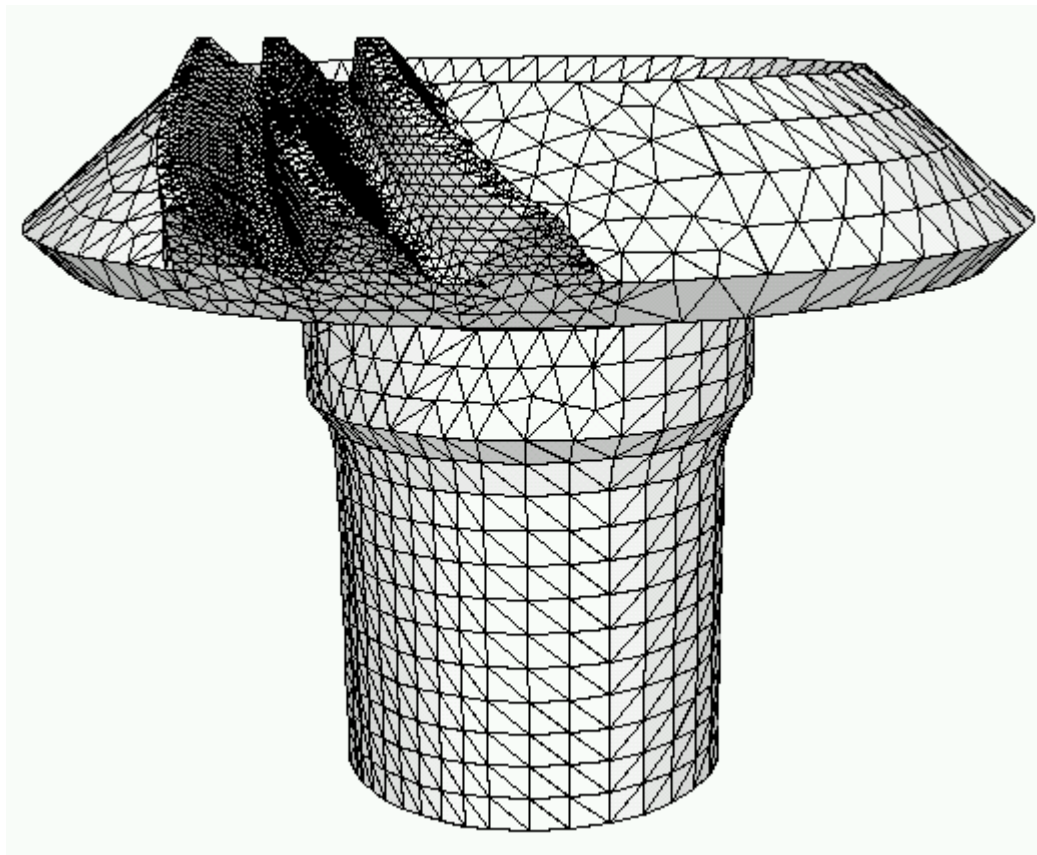

3-D Solid Model of the
EDM Notch

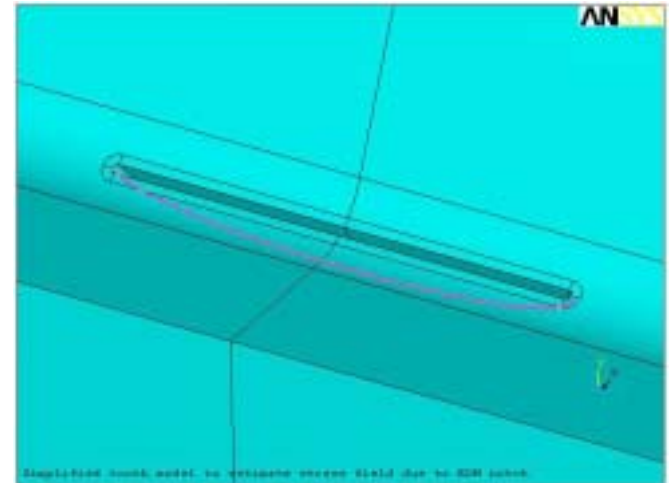

Fracture Surface Trajectory Actual vs Computed



Propagation through
the tooth area

**FRANC3D Code used for
Impact and AERA Efforts**

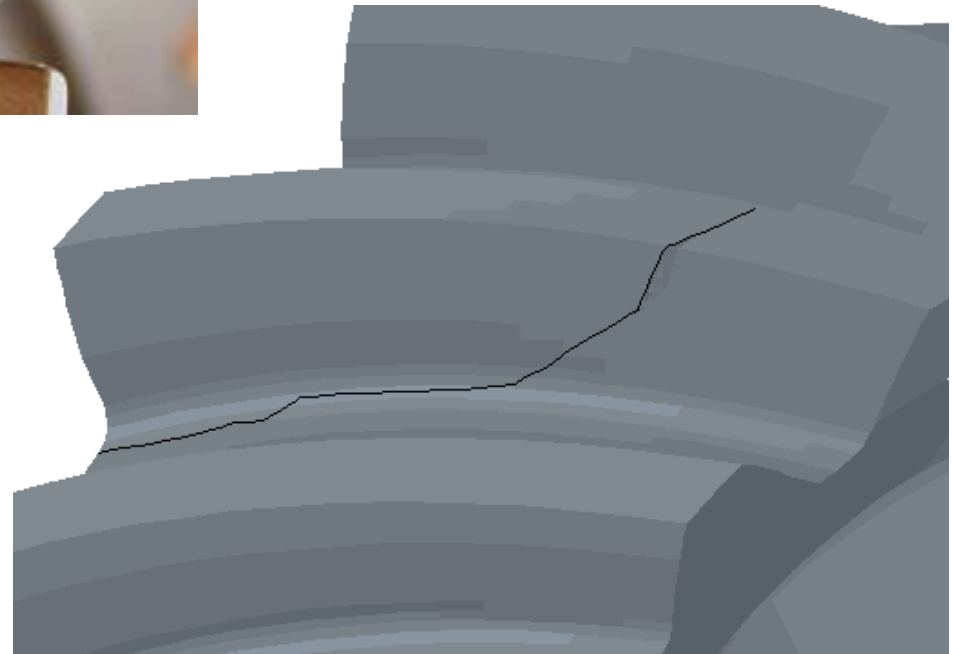

Fracture Surface Trajectory Actual vs Computed

Propagation through the web area

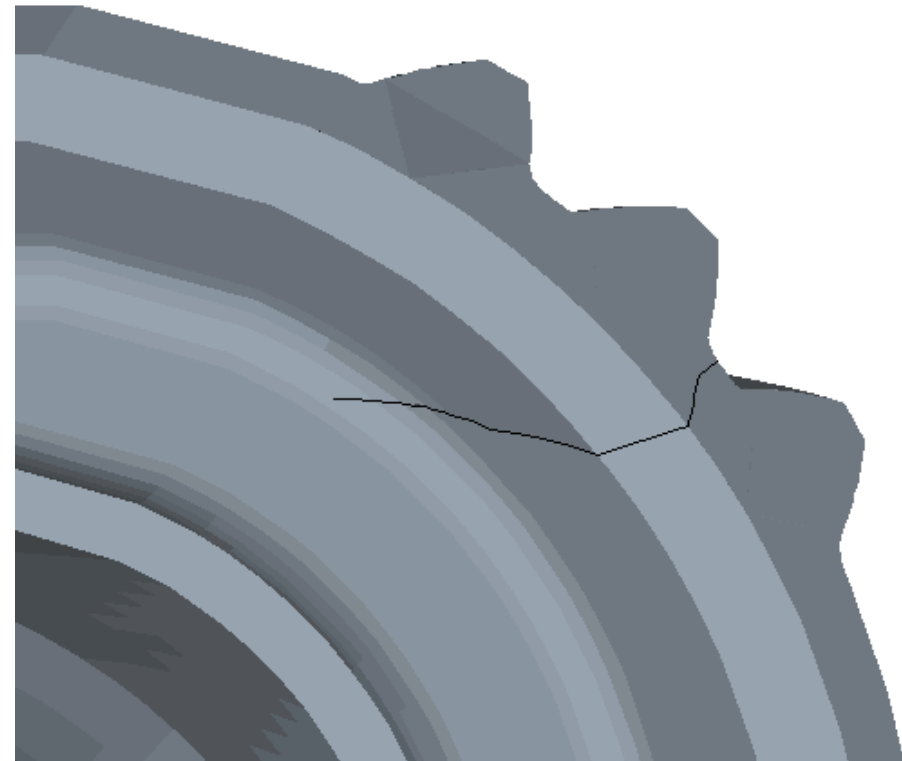
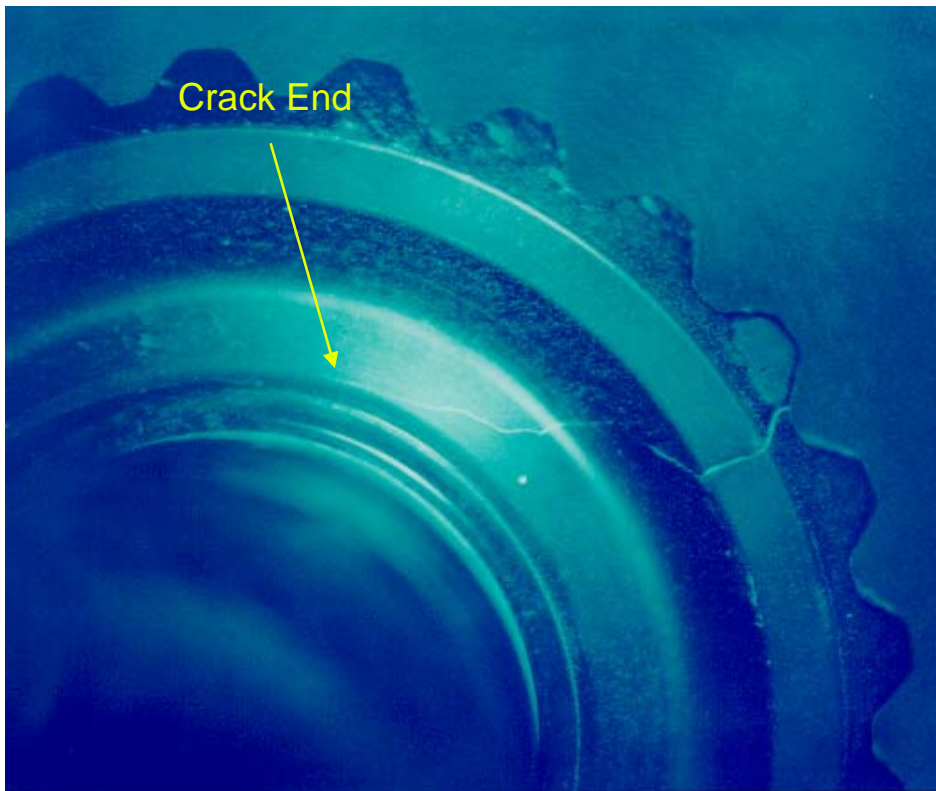

- Fractographic analysis used to estimate total run time to presence of 0.75 mil crack
- Test 1 operating profile more complex than test 2
- Model predicts 98% probability of 0.75 mil crack for test 1 and 63% probability for test 2

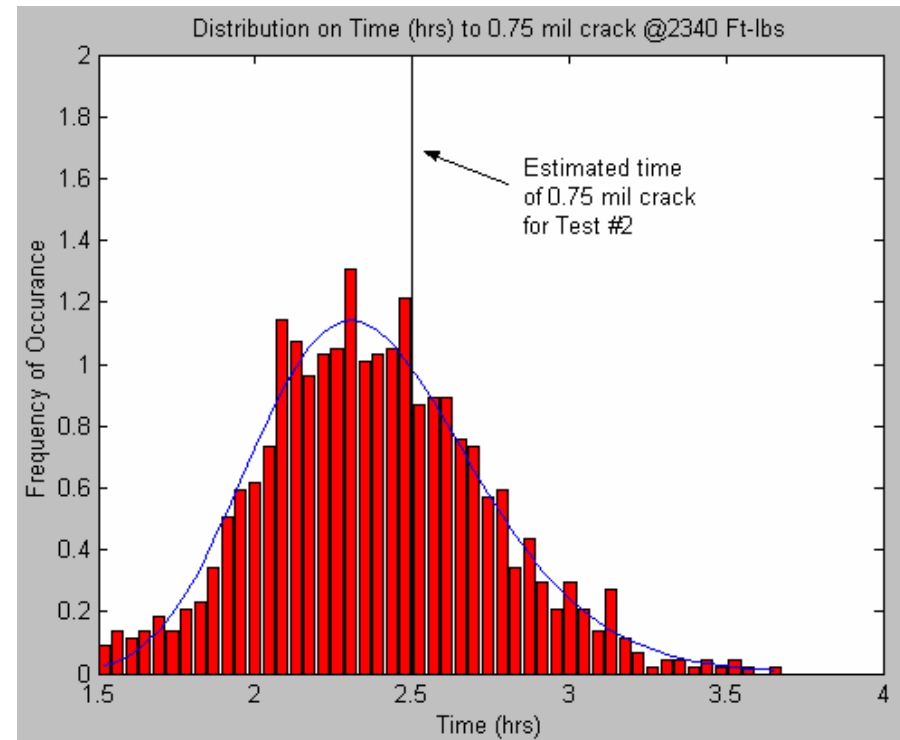
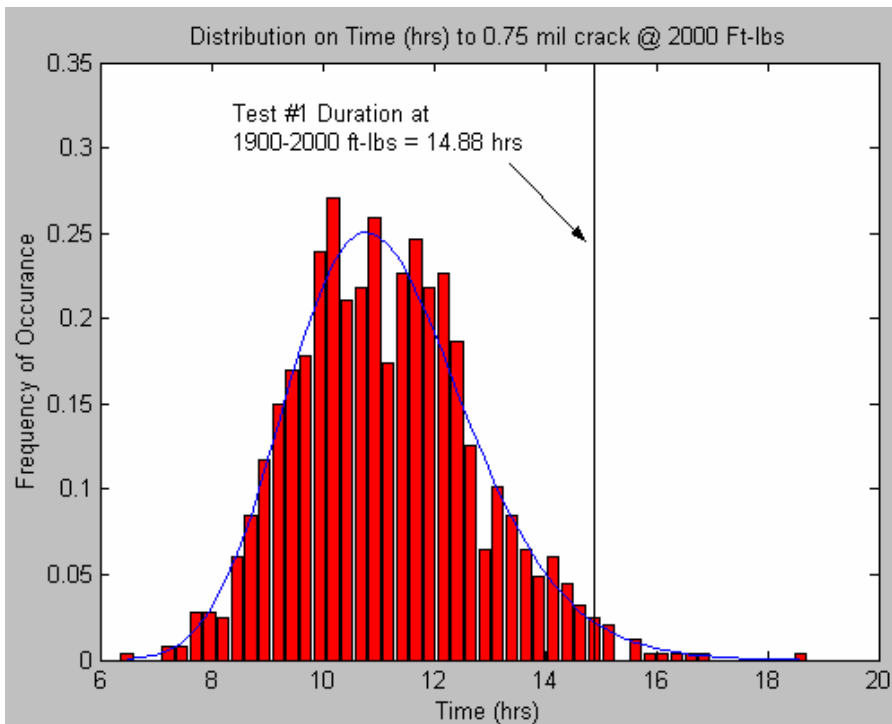

Current DARPA Program RSF Test Article

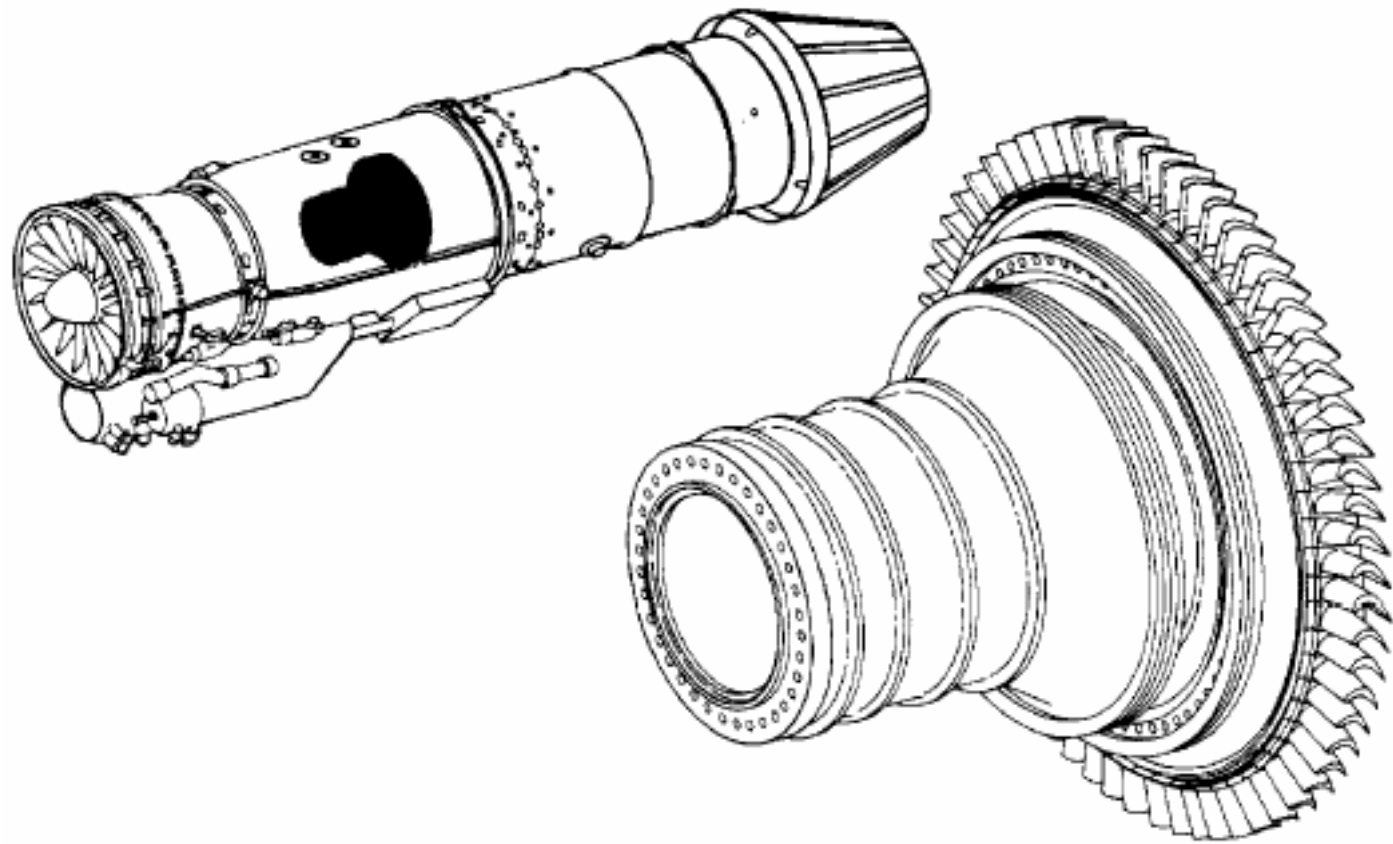

F404 High Pressure Turbine

PAX River Rotor Spin Facility

Spin Chamber Configuration

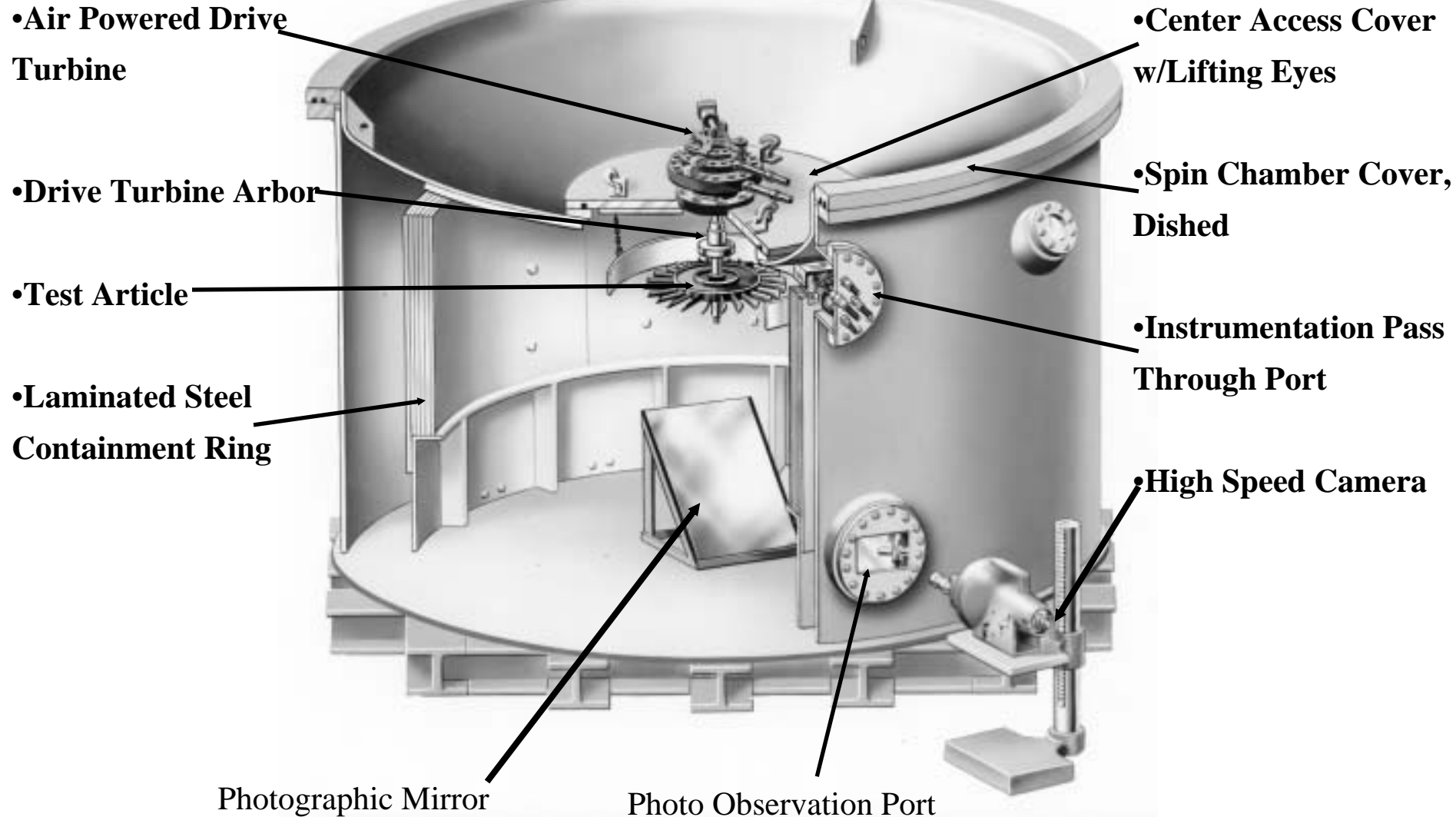

Rendering of Test Article Installed in Rotor Spin Facility

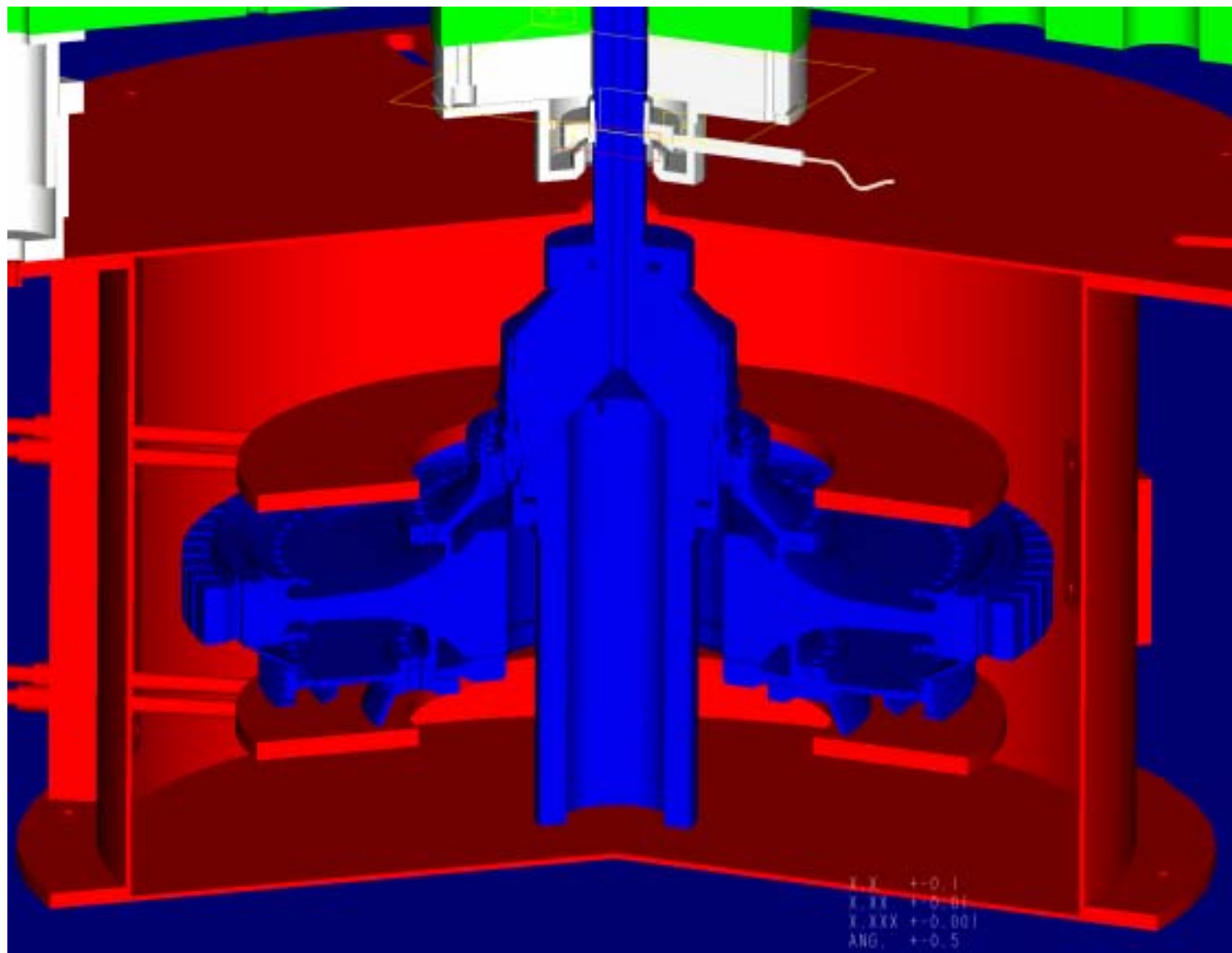

Current DARPA Program General Overview



- Multiple failure mechanisms incorporated
 - Low Cycle Fatigue
 - Dwell
- Multiple test articles each with several flaws
- Exercise current life models
- Incorporate latest advances in modeling
- Utilize state awareness sensors to detect developing cracks
- Develop integrated models which incorporate crack detection sensor outputs to recalibrate life models
- Predict crack growth behavior as accurately as possible

- State Awareness, Modeling, Material Science/Physics, Reasoning are integral to achieving prognostics
- Initial proof of concept work demonstrates some fundamental concepts central to achieving the prognosis vision
- We are just getting started!