



Human Infrastructure Detection and Exploitation (HIDE)

**by Raju Damarla, Barry O'Brien, Matthew Thielke, Gary Chatters,
Jonathan Fine, Steve Vinci, Greg Samples, Richard Gregory, Jeff Houser,
Alan Edelstein, Alex Chan, Greg Fischer, Patti Gillespie, and
Michael Patterson**

NOTICES

Disclaimers

The findings in this report are not to be construed as an official Department of the Army position unless so designated by other authorized documents.

Citation of manufacturer's or trade names does not constitute an official endorsement or approval of the use thereof.

Destroy this report when it is no longer needed. Do not return it to the originator.

Army Research Laboratory

Adelphi, MD 20783-1197

ARL-TR-5030

November 2009

Human Infrastructure Detection and Exploitation (HIDE)

**Raju Damarla, Barry O'Brien, Matthew Thielke, Gary Chatters,
Jonathan Fine, Steve Vinci, Greg Samples, Richard Gregory, Jeff Houser,
Alan Edelstein, Alex Chan, Greg Fischer, Patti Gillespie, and
Michael Patterson
Sensors and Electron Devices Directorate, ARL**

REPORT DOCUMENTATION PAGE

Form Approved
OMB No. 0704-0188

Public reporting burden for this collection of information is estimated to average 1 hour per response, including the time for reviewing instructions, searching existing data sources, gathering and maintaining the data needed, and completing and reviewing the collection information. Send comments regarding this burden estimate or any other aspect of this collection of information, including suggestions for reducing the burden, to Department of Defense, Washington Headquarters Services, Directorate for Information Operations and Reports (0704-0188), 1215 Jefferson Davis Highway, Suite 1204, Arlington, VA 22202-4302. Respondents should be aware that notwithstanding any other provision of law, no person shall be subject to any penalty for failing to comply with a collection of information if it does not display a currently valid OMB control number.

PLEASE DO NOT RETURN YOUR FORM TO THE ABOVE ADDRESS.

1. REPORT DATE (DD-MM-YYYY) November 2009		2. REPORT TYPE Final		3. DATES COVERED (From - To) 2005 to 2008	
4. TITLE AND SUBTITLE Human Infrastructure Detection and Exploitation (HIDE)				5a. CONTRACT NUMBER	
				5b. GRANT NUMBER	
				5c. PROGRAM ELEMENT NUMBER	
6. AUTHOR(S) Raju Damarla, Barry O'Brien, Matthew Thielke, Gary Chatters, Jonathan Fine, Steve Vinci, Greg Samples, Richard Gregory, Jeff Houser, Alan Edelstein, Alex Chan, Greg Fischer, Patti Gillespie, and Michael Patterson				5d. PROJECT NUMBER	
				5e. TASK NUMBER	
				5f. WORK UNIT NUMBER	
7. PERFORMING ORGANIZATION NAME(S) AND ADDRESS(ES) U.S. Army Research Laboratory ATTN RDRL-SES-A 2800 Powder Mill Road Adelphi, MD 20783-1197				8. PERFORMING ORGANIZATION REPORT NUMBER ARL-TR-5030	
9. SPONSORING/MONITORING AGENCY NAME(S) AND ADDRESS(ES)				10. SPONSOR/MONITOR'S ACRONYM(S)	
				11. SPONSOR/MONITOR'S REPORT NUMBER(S)	
12. DISTRIBUTION/AVAILABILITY STATEMENT Approved for public release; distribution unlimited.					
13. SUPPLEMENTARY NOTES					
14. ABSTRACT In this effort, we investigate and demonstrate multimodal, low-cost sensing on a mobile platform for detecting the presence of manmade "infrastructure" such as machinery, electric currents, chemicals, hazardous materials, and computers in hidden and confined spaces such as tunnels, sewers, caves, bunkers, and buildings. We developed new and innovative algorithms to perform node-level sensor fusion and provide information to the individual Soldier, squad and above. The proposed Army Technology Objective (ATO), Human Infrastructure Detection and Exploitation (HIDE), will develop the algorithms and sensor fusion capabilities and will not be developing the sensors or the robotics. This will be applicable for both Force Protection and urban intelligence, surveillance, and reconnaissance (ISR).					
15. SUBJECT TERMS HIDE, Personnel detection, infrastructure detection, Dempster-Shafer fusion, multi-modal sensors					
16. SECURITY CLASSIFICATION OF:			17. LIMITATION OF ABSTRACT UU	18. NUMBER OF PAGES 56	19a. NAME OF RESPONSIBLE PERSON Raju Damarla
a. REPORT Unclassified	b. ABSTRACT Unclassified	c. THIS PAGE Unclassified			19b. TELEPHONE NUMBER (Include area code) (301) 394-1266

Contents

List of Figures	v
List of Tables	vi
1. Fact Sheet	1
1.1 Detailed Description of Human Infrastructure Detection and Exploitation (HIDE) Army Technology Objective (ATO)	1
1.2 What is the Problem?	1
1.3 What are the Technical Barriers to Solving this Problem?	2
1.4 How will you Overcome Those Technical Barriers?	2
1.5 Identify Alternative Approaches/Technologies to Accomplish/Enhance ATO Objective(s)	2
1.6 What is/are the Result(s) of this ATO?	3
1.7 What is the Potential Payoff?	3
2. Introduction	3
3. Sensor Suite, Data Collection Unit, and Mobile Platform	5
3.1 The Sensor Suite	5
3.2 Data Collection	10
3.3 Mobile Platform	11
4. Data Collection for Phenomenology	13
4.1 Phenomenology to Observe	13
4.1 Data Collection in Building 507 and Building 203	14
4.1.1 Machine Shop Experiment	14
4.1.2 Conference Room Experiment	16
4.1.3 Bathroom Scenario	17
4.1.4 Vent Closing and Opening	17
4.1.5 Portable Generator and Air Compressor	18
4.1.6 Use of Keypad of a Computer and Use of Computer Monitors	18
4.1.7 Personnel Detection	18
4.1.8 Telephone Scenario	19

4.2	Data Collection at Center for National Response	19
4.3	Data Collection in South Parking Lot Trailer	25
5.	Algorithm Development	25
5.1	Acoustic Algorithms.....	25
5.2	Seismic Detection Algorithms.....	28
5.3	PIR Detection Algorithm for Personnel	29
5.4	Magnetic Sensor Algorithms.....	29
5.5	E-field Sensor Algorithms.....	30
5.6	Video Motion Detection Algorithm for Personnel Detection	30
5.7	Video Detection Algorithms for Thermal Profiling.....	30
5.8	Personnel Detection using IR Imager.....	31
6.	PackBot Platform Effect on Sensor Data and Processing	32
7.	Sensor Fusion	38
8.	Capstone Demo	42
9.	Publication from HIDE ATO Work	43
10.	References	44
	List of Symbols, Abbreviations, and Acronyms	46
	Distribution List	47

List of Figures

Figure 1. Single microphone and an array (tetrahedral) of microphones.	5
Figure 2. Seismic sensors.....	6
Figure 3. Picture of a PIR sensor.	7
Figure 4. Picture of the fluxgate magnetometer and the coil-type magnetic sensor.....	7
Figure 5. Picture of the three-axis E-field sensor.	8
Figure 6. Picture of a chemical sensor.	9
Figure 7. Picture of the visible and IR cameras.	9
Figure 8. Details of the HMDC.....	10
Figure 9. HMDC unit.....	11
Figure 10. PackBot.....	12
Figure 11. PackBot with sensors mounted.....	12
Figure 12. Machine experiment setup.....	15
Figure 13. Chairs' thermal profile.	20
Figure 14. Burner before use and in use.	20
Figure 15. Drill press signatures.	20
Figure 16. Conference room scene before and after use.....	21
Figure 17. Shower scenario.....	23
Figure 18. Computer scenario signatures.....	24
Figure 19. System flow chart for algorithm development.	25
Figure 20. Block diagram for the acoustic detection algorithm.....	27
Figure 21. Seismic detection algorithm.	29
Figure 22. Registration of video and IR images.	31
Figure 23. (a) Thermal image of the monitor without a person in front, (b) a person in front of the monitor, (c) the hot surfaces extracted from the image (b), and (d) a silhouette of a person extracted from (c).....	32
Figure 24. Acoustic data spectrum before and after noise removal.....	33
Figure 25. (a) Block diagram for acoustic data processing and (b) acoustic signal and probability of detection.	34
Figure 26. Seismic data spectrum before and after noise removal.	34
Figure 27. Seismic signatures and probability of detection.	35
Figure 28. PIR signatures and probability of detection.	36
Figure 29. E-field data spectrum before and after noise removal.....	36

Figure 30. E-field data and detections by the algorithm.....	37
Figure 31. Magnetic field data and detection by the algorithm.	37
Figure 32. Results of fusion using acoustic sensors.	40
Figure 33. Probability of detection using acoustic and seismic data.	41
Figure 34. Detection before and after fusion.	41
Figure 35. Demo scenario.....	42

List of Tables

Table 1. Sampling rate allocation for each sensor modality.....	11
---	----

1. Fact Sheet

1.1 Detailed Description of Human Infrastructure Detection and Exploitation (HIDE) Army Technology Objective (ATO)

The ability to use many sensors and process the data at the sensor node will provide new intelligence, surveillance, and reconnaissance (ISR) and Force Protection capabilities. This approach allows detection of targets which we cannot currently detect, improves ISR robustness, decreases false alarms, and simplifies employment as compared to systems that use single modality sensor nodes. This effort focuses on the development of algorithms, not the sensors, applied to detection of human infrastructure presence, such as machinery, currents in wires, computer emanations, industrial compounds, and humans themselves in confined spaces, using a variety of low-cost sensors including acoustic, seismic, magnetic, electrostatic (E-field), passive infrared (PIR), chemical, radio frequency (RF), and optical imagers. The algorithms will be structured to be adaptable to varying combinations of sensor modalities, environmental conditions, and varying missions. The algorithms and sensors will be integrated on a small mobile unmanned ground vehicle (UGV). The ATO will not develop a platform or robotic controls, but will leverage the ongoing Command & Control for Complex & Urban Terrain (C2CUT) ATO and other UGV efforts, and will integrate sensors onto an existing system(s). Initial efforts will concentrate on a limited application of detection of manmade machinery and human activity in hidden/confided spaces. In the latter part of the ATO, coordination with Communications-Electronics Research Development and Engineering Center (CERDEC) Intelligence and Information Warfare Director/Directorate (I2WD) will tailor efforts for transition to meet CERDEC I2WD's Multi-INT program requirements. In addition, the U.S. Army Research Laboratory (ARL) is coordinating this ATO with other programs, such as the Suite of Sense-Through-The Wall (STTW) Systems for the Future Force ATO [D] to assure compatibility and no duplication of effort. In fiscal year (FY) 06, they developed a test bed for multi-modal sensing, determined fusion algorithm criteria, and performed initial data collection experiments. In FY07, they developed and evaluated detection algorithms; initiated fusion algorithm development; addressed mobility and robotic platform issues; and performed field experiments. In FY08, they completed and evaluated the fusion algorithms, and conducted a final ATO demonstration.

1.2 What is the Problem?

Finding human infrastructure elements such as machinery, chemicals, RF emissions or other evidence of human activity in confined enclosed spaces is a deficiency in current ISR systems. In addition, operations in these places present a threat to Soldiers and detection of these types of presences is a needed capability.

1.3 What are the Technical Barriers to Solving this Problem?

- No single sensing modality can produce a robust ISR detection capability.
- No sensor fusion algorithms exist for sensor node level 0/1 fusion.
- There is insufficient understanding of sensor signatures and their interactions in these environments.

1.4 How will you Overcome Those Technical Barriers?

- Collect hyper-modal co-registered sensor data and signatures in relevant environments.
- Develop robust hyper-modal sensor fusion algorithms.
- Develop a correlation matrix to establish relationships between sensor detection capabilities and relevant target signatures.

1.5 Identify Alternative Approaches/Technologies to Accomplish/Enhance ATO Objective(s)

This approach will bridge the gap between high-cost large sensor systems and the very low-cost systems currently under development. These proposed sensor systems will afford more processing power and a larger footprint due to the fact that they are mounted on a platform that can provide power. This ATO will not develop these sensors, only use them to collect the data required to initiate sensor and fusion algorithms. This effort will go beyond current programs to look at significantly more sensing modalities on a single platform. Development of hyper-modal low-cost sensors on a small mobile platform for ISR capability has not been attempted. ARL has been discussing cooperative interaction with Sandia Laboratories, Albuquerque, NM, on the Virtual Perimeter Security (VPS) Grand Challenge effort and integration of the ARL algorithms into the Sandia simulation models. ARL is also working with CERDEC's Night Vision and Electronic Sensors Director/Directorate to integrate into their ongoing modeling and simulation efforts. These models will enable sensor evaluation and location planning of future sensor networks. ARL has also been interacting with the United States Special Operations Command (USSOCOM) to develop transition opportunities. USSOCOM is including this effort in their TTL Technology Roadmap. Applied research in this ATO will leverage basic research conducted under the Personnel Detection Multi-University Research Initiative (MURI), the Microsensors Collaborative Technology Alliance (CTA), and an internal ARL sensor fusion research effort. Sensor fusion is a critical technology for many future sensor systems, and ARL has integrated additional research in fusion into the ARL research. We also plan to leverage future work done in Army Research Office (ARO) sponsored MURIs and individual investigator projects. Not only is the basic understanding of how humans detect and classify targets lacking, but the fusion processes are even less well understood.

1.6 What is/are the Result(s) of this ATO?

- An integrated hyper-modal sensor test bed tailored for urban operations
- Node-based algorithms for detecting human infrastructure presence in hidden/confined spaces
- A database of co-registered, hyper-modal relevant signatures and features that are detectable with available sensor technology

1.7 What is the Potential Payoff?

Successful completion of this technology will provide a significant advancement to Force Protection and allow assessment of dangers in confined urban environments without putting Soldiers in harm's way. In addition, successful completion of this technology will enhance urban ISR capabilities. The algorithms developed in this ATO will provide increased detection and lower false alarm rates than current capabilities. Technologies developed should allow detection and localization of threats, which cannot be done currently.

2. Introduction

HIDE is an ATO of ARL's Signal and Image Processing Division with the objective of detecting human infrastructure and human activity in difficult terrains, such as caves, tunnels, bunkers, etc., and in urban environments using a sensor suite coupled with a mobile robotic platform. Recently, due to the global war on terrorism, individuals have increasingly become targets of interest along with their activity. So detection of humans and human infrastructure is a main focus for this ATO. In order to obtain better ISR, one needs to obtain sensor information and process it to extract the right information for ISR. Traditionally, video has been the main choice sensor for ISR, but it becomes useless if its field of view (FOV) is limited and it cannot observe occluded areas. Similarly, other sensors have their limitations, for example, acoustic sensors are prone to poor performance if there is loud background noise. Hence, no single sensor is capable of solving the ISR problem. The best approach for better ISR is to use a multimodal, low-cost multi-sensor sensing suite consisting of acoustic, seismic, PIR, chemical, magnetic, and E-field sensors. Since the detection of the humans and human infrastructure is done in remote locations, such as caves, tunnels, and urban areas that may be hostile, it is appropriate to use a mobile platform equipped with a multimodal sensing suite. We used a PackBot that can be maneuvered in difficult terrains as the platform for mounting sensors. Some of the sensors used are acoustic, seismic, PIR, chemical, magnetic, and E-field sensors along with video and infrared cameras. Each sensor has its own unique characteristics that complement with other sensing modalities in obtaining ISR. Some of the characteristics are listed below:

- **Acoustic** sensors use piezoelectric microphones with a frequency response of 20 Hz to 20 KHz. Acoustic sensors are low-cost sensors used to detect any acoustic signatures generated by people or machines. Unlike some sensors, acoustic sensors are omnidirectional: they do not require line of sight to the target. As a result, they can be deployed anywhere in the scene without worrying about line of sight. If more than one microphone is employed, acoustic sensors can provide a pointing vector to the direction of the source of the acoustic signature.
- **Seismic** sensors are three-axis sensors that can detect the vibrations in the ground. They are used to detect footfalls, vibrations caused by machines being operated, etc. Accelerometers can also detect vibrations in pipes produced by water flow. The sensitivity of these sensors generally depends on the core and the number of turns used in a coil that moves in the core. The frequency response also varies from device to device. The normal operating frequency range of the seismic sensor used for this experiment is 20 to 100 Hz.
- **Magnetic** (B-field) sensors can be used to detect ferromagnetic materials carried by people, e.g., keys, firearms, and knives. These sensors may also be used to detect the usage of computer monitors.
- **Electrostatic** (E-field) sensors can be used to detect the built-up electric charge on personnel. Together with magnetic sensors, they can also detect electrical activity in the vicinity, such as the usage of computer keyboards.
- **Chemical** sensors can be used to detect the presence of different kinds of chemicals in the atmosphere, such as pheromones and household chemical vapors.
- **PIR** devices are very inexpensive sensors that detect the nearby presence of a warm body, e.g., a human, within a cone-shaped FOV. These sensors are basically motion detectors.
- **Visible imagers** can capture color or grayscale video for human gait detection and object recognition.
- **Infrared imagers** can detect and localize hot bodies and warm surfaces, including vents in tunnels. They can also provide thermal profiling of buildings, where warmer rooms are indicative of current or recent human habitation.

3. Sensor Suite, Data Collection Unit, and Mobile Platform

In this section, we present the detailed description of the sensors and the data collection unit used in the HIDE ATO. We also describe some of the features of the mobile platform used, how the sensors are mounted on the mobile platform, and the interface between the sensor suite and the platform.

3.1 The Sensor Suite

Acoustic: The acoustic sensors used (figure 1) are piezoelectric microphones. Acoustic sensors are low-cost sensors used to detect any acoustic signatures generated by people or machines. Unlike some of the sensors, these sensors are omnidirectional: they do not require line of sight to the target. As a result, they can be deployed anywhere in the scene without worrying about line of sight. If more than one microphone is employed, acoustic sensors can provide a pointing vector to the direction of the source of the acoustic signature.



Figure 1. Single microphone and an array (tetrahedral) of microphones.

Detail metadata pertinent to this modality were recorded. The microphone used in the experiment is a Knowles microphone that has the frequency response 20 Hz to 20 KHz. The data are collected at 16 K samples per second, which provides a bandwidth of 8 KHz that captures both voice and machine signatures with good fidelity for the HIDE ATO purposes.

Seismic: Seismic sensors are similar to the acoustic sensors and are used to capture vibrations such as (1) footfalls when people are walking, (2) vibrations caused by the machines in operation, and (3) water flow through pipes, to name a few. Seismic sensors measure the vibrations in all three axes. The sensitivity of the sensors generally depends on the core and the

number of turns used in a coil that moves in the core. The frequency response also varies from device to device.

The data are collected at 16 K samples per second. This is to enable the sensor to capture vibrations from machines. Figure 2 shows the pictures of some of the seismic sensors. The Tri-axis seismic sensor on the right is the one used for data collection.



Figure 2. Seismic sensors.

PIR: PIR devices (figure 3) are very inexpensive sensors that detect the nearby presence of a warm body, e.g., a human, within a cone-shaped FOV. The FOV of the sensor is determined by the lens in front of the actual device. We employed two different PIRs one with a 15° FOV and one with a 60° FOV. We also employed a sensor with charging plates, one charges positively and another charges negatively. Depending on the direction of the person, either the positive and then negative charging plates charge or vice versa, thus making it is possible to determine the direction of motion of a target.

PIRs are the most reliable sensors in terms of detection; however, they do not distinguish whether the target is human, animal, or an inanimate object. They only record the thermal signature generated by the target.

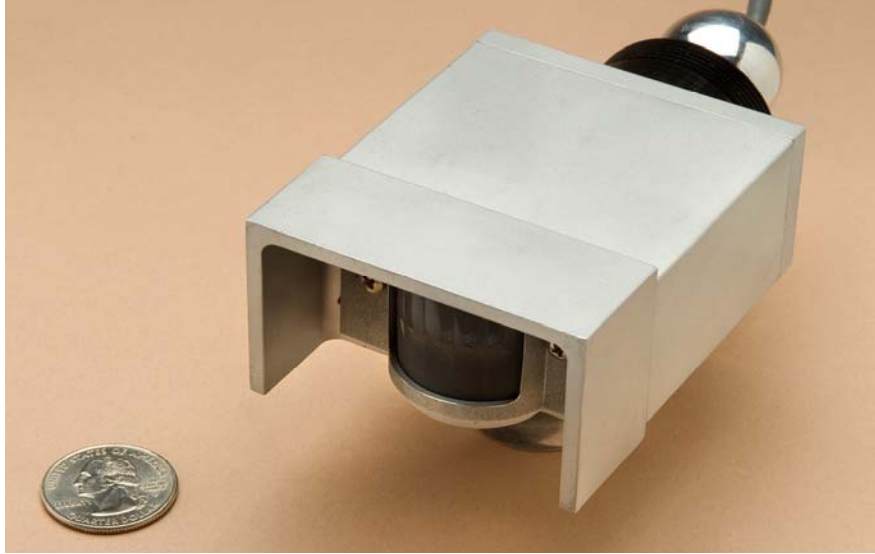

Figure 3. Picture of a PIR sensor.

Magnetic (B-field): Magnetic (B-field) sensors can be used to detect ferromagnetic materials carried by people, e.g., keys, firearms, and knives. These sensors may also be used to detect the usage of computer monitors. We used two different B-field sensors (figure 4), namely, (1) a fluxgate magnetometer and (2) a coil-type magnetic sensor. Three Quasar single-axis 8-in Model BS-1004 magnetic coil magnetic sensors with a sensitivity of 0.116 V/nT (nT – nano Tesla) were used. They were aligned with the x -, y -, and z -axes to record flux change in three directions. The data from these coils were collected at 256 samples per second. The three-axis fluxgate magnetometer used was an Applied Physics Systems Model 1540. It has the sensitivity of 30 μ V/nT and is used to detect the low frequency components up to 5 Hz. The data from the fluxgate magnetometer were collected at 10 samples per second.

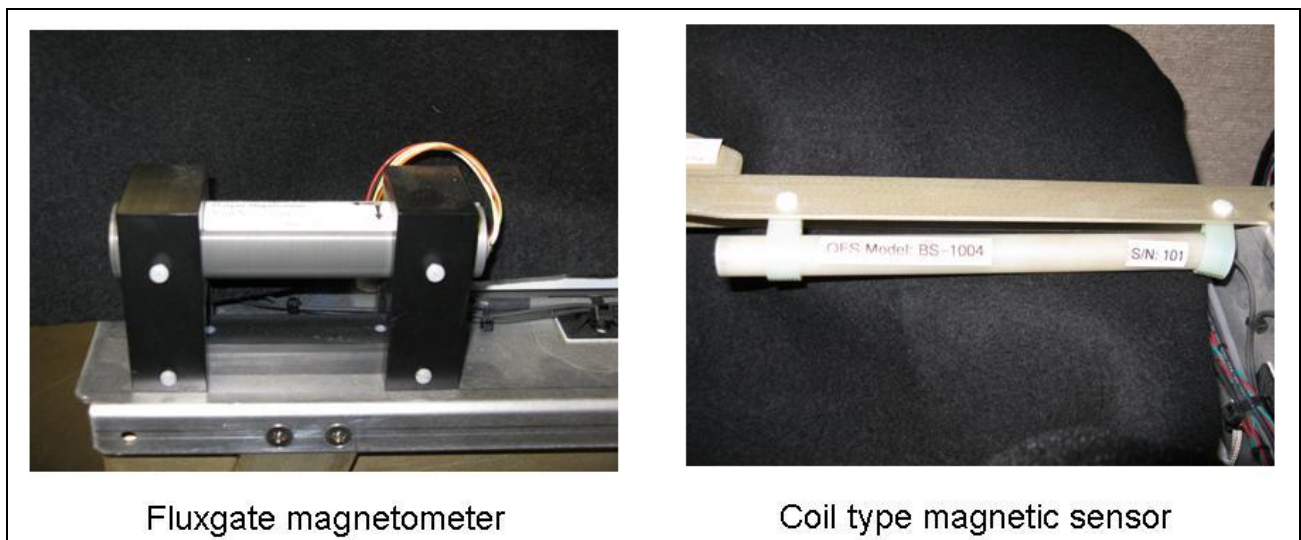

Figure 4. Picture of the fluxgate magnetometer and the coil-type magnetic sensor.

Electrostatic (E-field): The E-field sensor used on the HIDE ATO robot was an ES-3000C produced by Quasar Federal Systems (QFS) (figure 5). Using three pairs of sensing paddles, this sensor provides an analog output for each of the axes, which is accomplished by taking difference measurements of the free-space potential at each probe pair. The corresponding E-field can be determined by dividing by the effective distance between the probes. Extremely low-noise amplifiers and drift stabilization circuitry allow accurate measurement of the free-space potential. The frequency response of the ES-3000C was from 100 mHz to 10 kHz, with a selectable 1-kHz low-pass filter. The sensitivity was 10 uV/m/rt Hz at 60 Hz with selectable sensor gain settings.

E-field data were collected at 8 K samples per second on all three channels, which gave us the fidelity to analyze the data carefully.

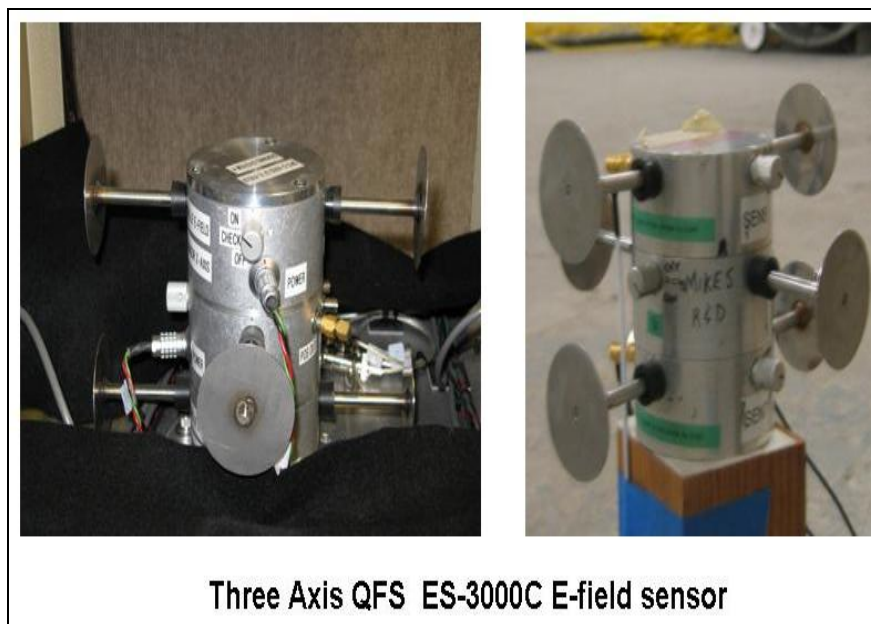

Figure 5. Picture of the three-axis E-field sensor.

Chemical: Chemical sensors are used to detect the presence of harmful chemicals in the vicinity. The chemical sensor used in HIDE ATO system development was a 16 channel multi-agent sensor that can detect 16 different chemicals (figure 6). The sensor uses 16 different wafers that react well with the chemical they are supposed to detect. A fan on the sensor diverts the flow of air over the wafers. Depending on the chemical present, one of the wafers reacts and increases the resistivity resulting in increase of output voltage.



Figure 6. Picture of a chemical sensor.

Visible and Infrared Imaging: Visible and infrared imaging sensors (figure 7) are the most widely used sensors in the sensing world, based on the old adages that a “picture is worth thousand words” or “seeing is believing.” The visible color video camera had a resolution of 768 x 494 active pixels, 1/4-in Charge-Coupled Device (CCD), and approximately 450 TV lines. The FOV was approximately 25°. The IR camera used was an un-cooled long-wave (8–12 micron) microbolometer with a FOV of 25° and a resolution of 160x120 focal plane array (FPA). The data were collected at 2 frames per second.



Figure 7. Picture of the visible and IR cameras.

3.2 Data Collection

In order collect the data using all the previously mentioned sensors, a Hyper Modal Data Collector (HMDC) data collection unit was built that was lightweight and could be mounted on a mobile platform such as a PackBot. The power for the data collection unit came from the batteries powering the mobile platform.

The following criteria were used while designing the HMDC:

- Scalable—Can operate as a stand-alone or in arrays.
- Expandable—Allows for the addition of new channels/sensors.
- Highly modular—Allows upgrades of individual sections without major redesign.
- Designed for field operation—low power, battery operated, rugged, portable, and weather resistant
- Flexible—Designed to accept various interface types.
- Global position system (GPS) time synchronized.

Figure 8 shows the design details of the HMDC. Prior to building the HMDC for HIDE ATO, several deliberations were made with the scientists/engineers involved on the bandwidth requirements for each sensor modality. It was decided, based on the applications where HIDE may be used, to assign the sampling rates for each sensor modality as outlined in table 1.

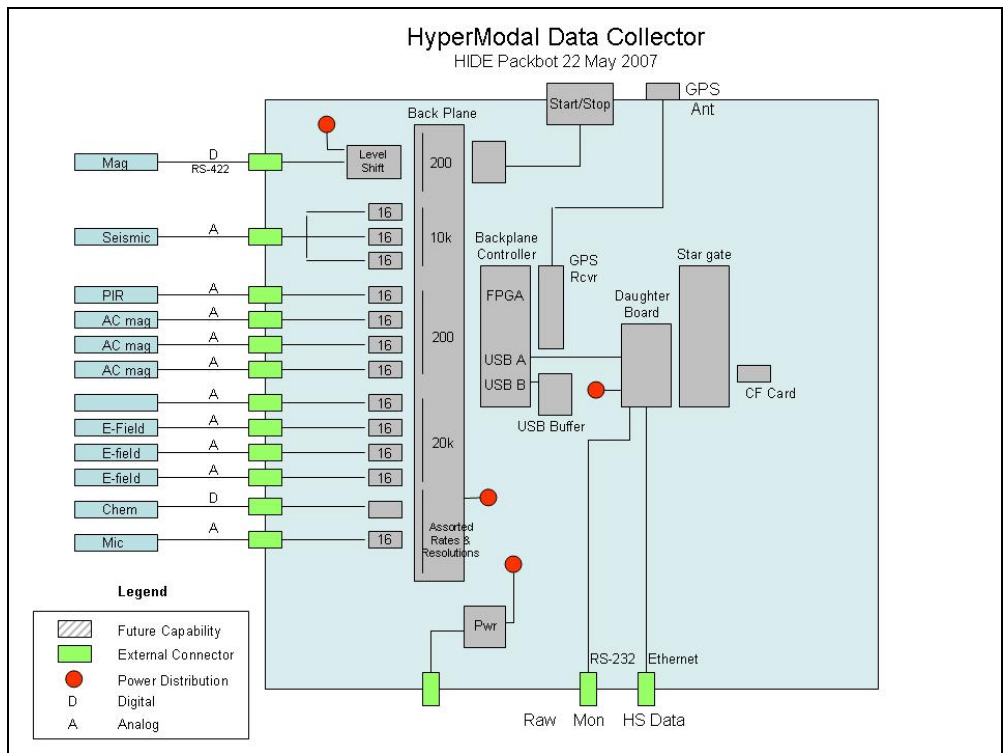

Figure 8. Details of the HMDC.

Table 1. Sampling rate allocation for each sensor modality.

Sensor Type	No. Channels	Sampling Rate	Resolution (bits)
Acoustic	4–Analog	16384	16
Seismic	3–Analog	16384	16
PIR	1–Analog	256	16
B-field (fluxgate)	3–Digital	10	24
B-field (coil)	3–Analog	256	16
E-field	3–Analog	8192	16
Chemical	16–Digital	1	
Temperature	1–Digital	10	24

Each individual channel has an anti-aliasing filter, and individual gain settings, which can be set using adjustable potentiometer. All the data collected by various sensing modalities were time synchronized with the GPS. A GPS receiver can be plugged to the HMDC for GPS signals. The final system is shown in figure 9.



Figure 9. HMDC unit.

3.3 Mobile Platform

One of the objectives of the HIDE ATO is to mount the disparate sensors on mobile platform that can be easily maneuvered in difficult terrains such as tunnels, caves, and buildings. Several mobile platforms, namely, mule, PackBot, etc., were considered as candidates. Based on the availability and maneuverability, we decided to proceed with the PackBot as the platform for integrating the sensor suite for the HIDE ATO. Figure 10 shows the picture of the PackBot before installing the sensors on it.



Figure 10. PackBot.

As one can see, the real-estate on the PackBot is limited for mounting all the sensors and the data collection unit shown in figure 9. We decided to build a platform on the PackBot to facilitate the installation of all the sensors.

Another important issue that we had to consider when allocating space for each sensor was the interference from sensors being in close proximity to each other. For example, the fan on the chemical sensor can interfere with the magnetic, E-field, acoustic, and seismic sensors. The PackBot picture with all the sensors mounted is shown in figure 11.

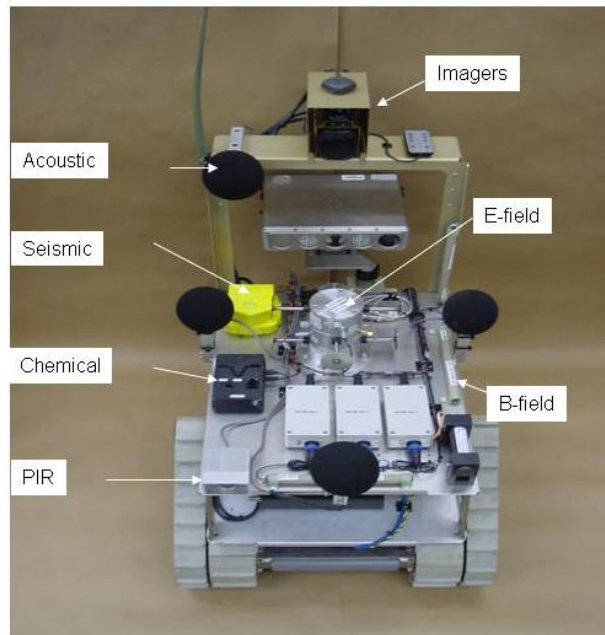

Figure 11. PackBot with sensors mounted.

The system in figure 11 is unique in the sense that it is the first time so many sensors have been integrated onto such a small platform.

Data collected by the HMDC were temporarily stored on the hard drive in the HMDC module. The video and IR imaging sensor data were remotely collected on a laptop few frames per second. Control of the PackBot was done remotely using the original video and IR cameras that came with the PackBot (see figure 10).

4. Data Collection for Phenomenology

Over the span of the HIDE ATO's duration (3 years), several data collection exercises were conducted to develop various fusion algorithms based on physics-based phenomenology. Algorithms based on phenomenology are robust and independent of application. Depending on the type of sensor and the target, several phenomenological observations were made by enacting the right scenario during the experimentation. Some of the phenomenology we tried to observe fell in two categories: direct observation and indirect observation. In the case of direct observation, we observed the targets face to face while they were in operation. In the case of indirect observation, we observed the targets after they were powered down or observed them while in operation through a wall or through a screen to see if these targets were used recently.

4.1 Phenomenology to Observe

- Electromagnetic radiation by use of machinery and electrical appliances
- Field changes in the vicinity of the appliances and indoor and outdoor power feeders
- Thermal profiles of the targets before and after usage
- Acoustic signatures of the targets in use
- Seismic signatures of the targets in use
- Chemical signature of the chemical agents present in the vicinity
- Signature of weapons
- Signatures of common utility containers, utensils, and furniture used on a daily basis

Some of the phenomenology we tried to observe and the sensors that may detect them are listed below:

- *Use of machinery in a building, cave, etc.:* It is possible to detect these using acoustic (sound), IR (hot surfaces of machines due to friction caused by rotating parts), seismic (vibrations caused by running machinery; electrostatic (rotating body and current through the wires), magnetic, and video (detection of moving parts, etc.).
- *Water flow in pipes:* When water is being used in a building, the flow of water in pipes makes distinctive sounds and vibrations. These sounds and vibrations may be detected by

acoustic, seismic, and accelerometers when water taps are opened and closed, when a flush is used, etc.

- *Flow of air through vents:* Temperature differentials can be detected by IR, and vibrations can be detected using seismic sensors/accelerometers, and possibly by acoustics.
- *Chemical usage:* Ammonia-based agents used for cleaning, etc., can be detected using chemical sensors. Other chemicals, like cockroach killer, methane, etc., might likewise be detectable.
- *Footsteps:* Footsteps can be detected by seismic and acoustic sensors.
- *Doors opening and closing:* Doors opening and closing can be detected by seismic, acoustic, IR, and video sensors.
- *Computer monitors:* The use of computer monitors and liquid crystal displays (LCDs) can be picked up by E-field and magnetic (possibly) sensors.
- *Telephone ringing, radio playing, etc.:* These noises can be detected by audio sensors.
- *Cell phone usage:* This can be detected by RF and E-field sensors.

We collected data to develop various algorithms in the following locations:

- Building 507 in the Adelphi Laboratory Center (ALC), MD
- Building 203 in ALC
- Center for National Response
- Trailer in South Parking Lot

4.1 Data Collection in Building 507 and Building 203

This is the first of the several experimental data collection efforts undertaken over the lifespan of the ATO. The place where the data collection will occur was primarily selected due to its isolation from nearby buildings and personnel: it is not affected by power lines, air-conditioning, or the day-to-day activities of folks in an office building. Several experiments for data collection will be conducted and their detailed descriptions follow.

4.1.1 Machine Shop Experiment

The objective of this experiment is to infer the presence of people by observing whether some of the machines are in use in a location or building. In this experiment, we will operate a drilling machine and a band saw (figure 12). The objective is to get the acoustic, seismic, B- and E-field, and thermal signatures of the machines in use. After the operation of the machines, we will determine how the thermal profiles of the machines change with time to determine how long ago these machines were in use.

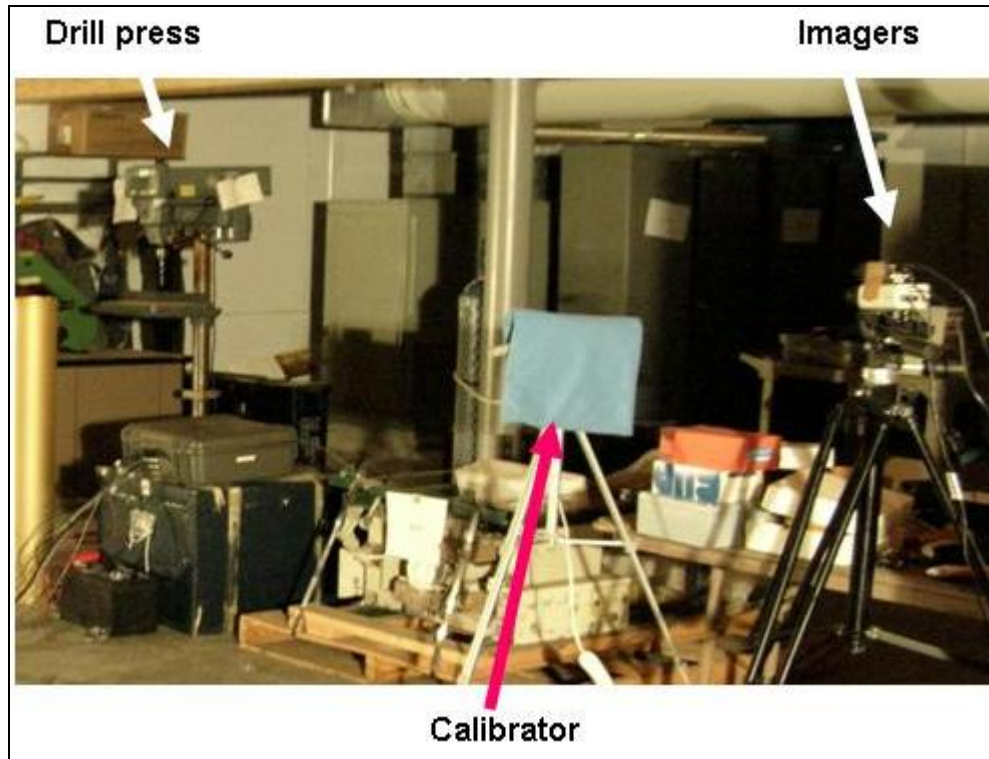

Figure 12. Machine experiment setup.

Experimental Setup:

- Place IR imagers focusing on the drill/band saw at about 16 ft from the instrument.
- Place acoustic sensor within 10–12 ft from the drill.
- Place PIR sensor 10–12 ft co-located with acoustics.
- Place seismic sensor 10–12 ft co-located with acoustics.
- Place magnetic sensors 5 ft from the drill.
- Place some E-field sensors near the AC power cable feeding the drill press, some near drill press, and some near the transformer outside the building/underground power line.
- Place chemical sensor 5 ft from the drill.
- Measure ground truth.
- Synch the clocks with GPS TIME for all sensors.
- Collect data on background noise (drill turned off) for 2 min.
- Turn on the drill (the person should move away from the machine shop) and collect data for 2 min.

- Turn off the drill (with the person gone) and collect data for 2 min.
- Let the drill to cool off.
- Repeat the above process by increasing the distance by $2x$ and $3x$, where x is the initial distance of the sensors from the drill.
- Collect background noise after all the above cycles are completed.

4.1.2 Conference Room Experiment

The objective of this experiment is to observe the people gathered around a conference table and the phenomenology that unfolds. The phenomenology may include the thermal imprints left by the people on chairs, tables, laptops, etc. It also includes the remnant cigar/cigarette butts left behind still smoldering or just extinguished. The experiment is used to capture acoustic, seismic, B- and E-field, PIR, chemical, video, and imaging sensor signatures.

Experimental Setup:

- Place IR imagers focusing on the table/chairs at about 12 ft.
- Place acoustic sensor within 10–12 ft from the chairs.
- Place PIR sensor 10–12 ft co-located with acoustics.
- Place seismic sensor 10–12 ft co-located with acoustics.
- Place magnetic sensors 5 ft from the chairs.
- Place E-field sensors near the AC power cable, some near chairs, and some near the transformer outside the building/underground power line.
- Place chemical sensor 5 ft from the chairs.
- Measure ground truth.
- Synch the clocks with GPS TIME (possibly outside).
- Collect data on back ground noise (without any person present) for 2 min.
- Three to four people sit on chairs and discuss/talk and collect data for 2 min while talking.
- Use a laptop for 2 min while collecting data.
- All people should leave the area. Collect data for 2 min.
- Repeat the above process by increasing the distance by $2x$ and $3x$, where x is the initial distance of the sensors from the table/chairs.
- Collect background noise after all the above cycles are completed

4.1.3 Bathroom Scenario

The objective of this experiment is to see if somebody is using water in a cave or building. If so, running water in pipes makes noise and causes vibrations. We would like to pick up those and more.

Experimental Setup:

- Place IR imagers focusing on the sink and commode.
- Place all sensors within 5 ft from the sink.
- Measure ground truth.
- Synch the clocks with GPS TIME (possibly outside).
- Collect data on back ground noise (without any person using the bathroom) for 2 min.
- Let a person use a sink or flush a toilet and collect data for 2 min.
- Let a person turn on a light before entering the bathroom and turn it off when the person leaves. Data are collected during this activity.
- Repeat the above process with sensors outside some placed near pipes running along the wall or ceiling, etc.

4.1.4 Vent Closing and Opening

The objective of this experiment is to infer if someone has opened a vent to let fresh air flow into a cave or has turned on an exhaust fan, etc. We would like to monitor those activities, which in turn gives clues about human activity.

Experimental Setup

- Place the magnetic sensors directly below the vent.
- Place the thermal imager trained on the vent.
- Place E-field sensors at appropriate locations (to monitor exhaust fan activity, etc.).
- Place the acoustic and seismic sensors close to the vent.
- Synchronize the clocks on test data collectors.
- Collect the background noise for 2 min before vent is opened.
- Collect data for 2 min after vent is opened.
- Repeat the cycle with exhaust fan turned on and off.

4.1.5 Portable Generator and Air Compressor

The objective of this experiment is to see if somebody is using a generator to power the facilities, etc. This depends heavily on magnetic and e-field sensors.

Experimental Setup:

- Set up the magnetic and E-field sensors as per the expert's advice.
- Place acoustic, seismic, and other sensors about 10–12 ft from the generator.
- Synch the clocks on the data collectors.
- Collect the background noise.
- Run a portable generator and collect data.
- Stop the generator and collect data
- Do the same with air compressor

4.1.6 Use of Keypad of a Computer and Use of Computer Monitors

The objective is to detect the E-field, magnetic, and acoustic signatures of a keypad when it is being used.

Experimental Setup:

- Set up the magnetic and E-field sensors as per the experts' advice.
- Place acoustic, seismic, and other sensors about 5–6 ft from the keypad.
- Take the ground truth.
- Synch the clocks on the data collectors.
- Collect the background noise.
- Collect data while typing on the keypad.
- Collect the data when the monitor is off and when it is on.

4.1.7 Personnel Detection

The objective is to detect people directly using all types of sensors.

Experimental Setup:

- Set up the sensors all around the facility.
- Take the ground truth.
- Synch the clocks on the data collectors.

- Have people walk up and down and take data.
- Do activities like smoking, typing, etc., for indirect detection.

4.1.8 Telephone Scenario

The objective is to detect usage of a cell phone/telephone.

Experimental Setup:

- Set up the sensors all around the facility; the magnetic and E-field sensor should be close to the telephone.
- Take the ground truth.
- Synch the clocks on the data collectors.
- Collect background noise.
- Let somebody ring the phone.
- Collect data while the telephone is ringing.

4.2 Data Collection at Center for National Response

Center for National Response (CNR) is a premier sight in the foothills of West Virginia's mountains that has several unique facilities: (1) a simulated cave, (2) a tunnel, (3) a bunker, and (4) trailers for performing various experiments. This facility allows us to simulate the facilities that our Soldiers may encounter in theater. A simulated cave may be used for enacting the scenario encountered in Afghanistan; a bunker may be used to simulate the conditions fugitives may be using in various parts of the world to hide, etc.

The data were collected over a period of three days. The first day the data were collected in a bunker. The bunker is a cinderblock room with a concrete ceiling mostly (3/4) buried in the ground, 125 in wide by 125 in long by 83 in high. From the ground to the center of the front microphone is 97 in. The door in the roof of the bunker is in the south corner. There are access points for the bunker in the southwest and southeast walls.

For all runs on Day 1, the PackBot looked into the bunker. The PackBot was tilted at an angle of -84.4° , pointing approximately northwest. The covers were open on the top of the bunker and on the access pit next to the bunker. Outside temperatures were measured using the dashboard thermometer in my Pontiac Vibe. Bunker temperatures were measured using a thermometer found in the bunker. The day started out chilly and in the shadow of the mountains, but by Run 5 we were in full sun. The experimental runs are listed as following:

Day 1 Data Collection List:

- Bunker Ambient Data Collection

- Bunker with 2 People Walking with Guns, Talking
- Bunker with 2 Empty Chairs Ambient Data Collection (figure 13)

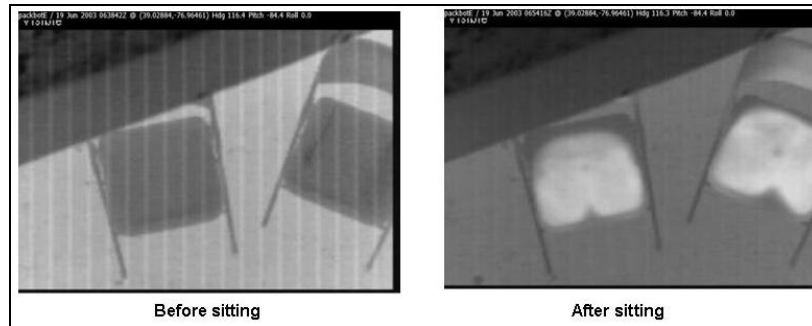

Figure 13. Chairs' thermal profile.

- Bunker with 2 People Sitting with Guns, Talking, Leaving/Cool Down
- Bunker with 2 People Sitting, Using Laptops
- Bunker with Coffee Pot (figure 14)

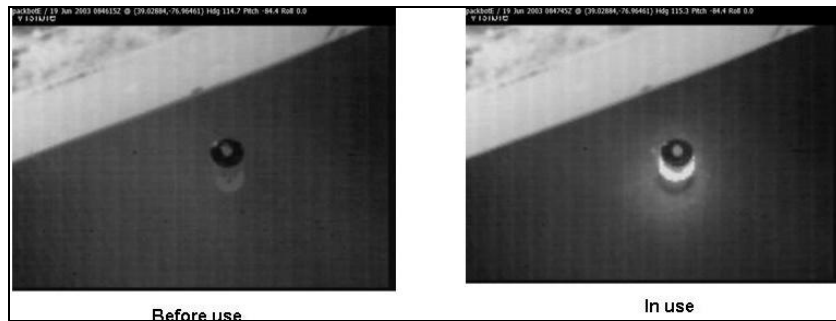

Figure 14. Burner before use and in use.

- Bunker with Person Sitting, Drinking Coffee, Smoking Cigar
- Bunker with Generator
- Bunker with Drill Press (Outside Generator) (figure 15)



Figure 15. Drill press signatures.

- Bunker with Drill Press (Battery and Inverter in Bunker)
- Bunker E- and B-field (No Imager)
- Bunker with Chemicals (Methyl Salicylate)
- Manmade Objects in Natural Background (Imager Only)

Day 2 Data Collection List:

Day 2 data collection was done primarily in a simulated cave. The cave was actually a series of rooms within the tunnel and has a base structure of 2 by 4's and plywood. The walls and ceiling were covered in foam. Chicken wire was attached to the top of the walls and across the ceiling to hold the foam in place. The main chamber of the cave was 11 ft, 9 in wide, and 21 ft long. For reference, the entrance to the main chamber was on the near wall, and had a 2 ft, 6 in wide opening, which was 1 ft from the left wall. There was also an exit opening on the far wall, which was 2 ft, 5 in wide and 1 ft from the left wall. The near and far walls were 11 ft, 9 in and the left and right walls were 21 ft.

The tunnel was illuminated by two-bulb fluorescent lights.

- Cave Entrance Ambient Data Collection
- Cave Main Chamber Ambient Data Collection
- Cave Sensor Operation Test
- Cave Conference Table scenario (figure 16)

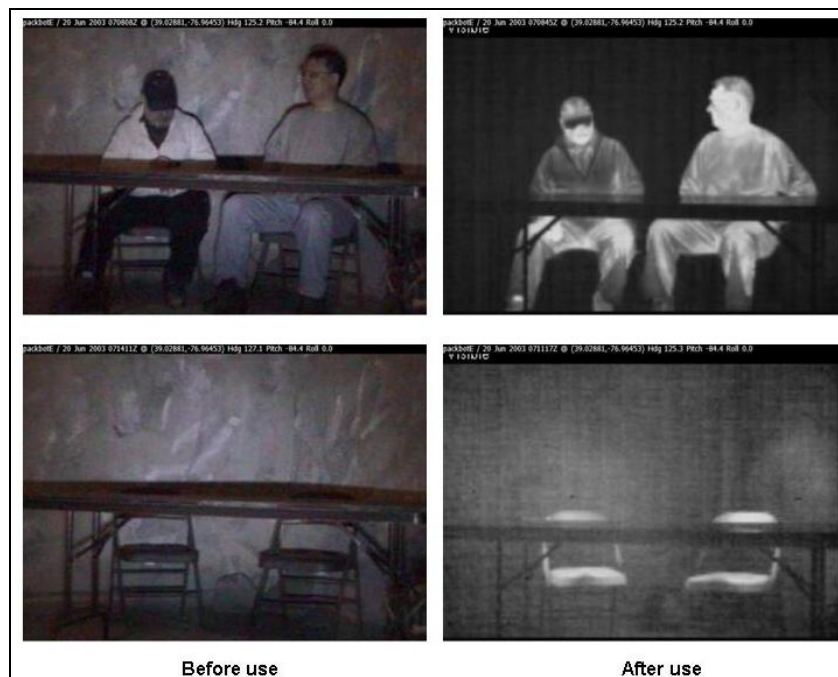

Figure 16. Conference room scene before and after use.

- Cave 2 People Sitting, Using Laptops
- Cave Radio Transmissions Test
- Cave Experiment with a Person Sitting, Smoking Cigar
- **Imager Registration** (done to calibrate the imaging sensors)
- Cave Drill Press (Outside Generator) Operation
- Cave Drill Press (Battery and Inverter in Cave) Operation
- Cave Experiment with Weapons/Movement
- Cave Experiment with Spices (cumin, cinnamon, cloves) on a Stove
- Cave Generator Operation Experiment
- Acoustic Calibration (No Images)

Day 3 Data Collection List:

Day 3 began with one run in the Egress Chamber to try to detect wiring and activity through a wall. We then moved to the Training Support Facility (TSF) for the remainder of the runs. We ran our tests in the Conference Trailer, which contained a larger central meeting room with kitchen facilities, adjoining smaller conference rooms on either end of the trailer, and a restroom on either end of the trailer. There was also a small computer room set up with five PCs with network connections.

- **Egress Chamber – Human Activity/Wiring through Wall**

The conference trailer was used for the remainder of the tests. In the main room, the background noises included a refrigerator running and eight fluorescent lights (four bulbs each).

- **Bathroom Scenario Experiment**

The purpose of this experiment was to detect any human activity such as turning on the lights in the bath room, flushing of toilet, or running water in the sink. We intended to detect these activities while they were being carried out or after they had been carried out by observing the thermal profile of the various facilities such as sink, bath tub, toilet seat, etc.

- **Toilet Scenario**

The objective here was to use a toilet seat and determine its thermal profile to see if it had been used recently.

- **Shower Scenario**

The objective here was to use a shower in the tub and leave. The thermal profile of the walls, tub, and handles should reveal the usage of the shower facility (figure 17).



Figure 17. Shower scenario.

- **Use of Cleaning Products**

If any of the chemical products had been used for cleaning purposes, their presence should be detectable in the bathroom for some time after their use, revealing recent human activity.

- **Office (Computer Room) Scenario**

In this experiment, data were collected while normal activity was taking place in an office, such as going into the room, turning on lights, starting the computer, working on the computer (keyboard activity), etc. Some of the human activity detection algorithms were developed to determine the usage of these instruments.

Notice in figure 18 that the thermal image of a person sitting in front of the monitor is reflected off of the monitor and captured by the IR imager.

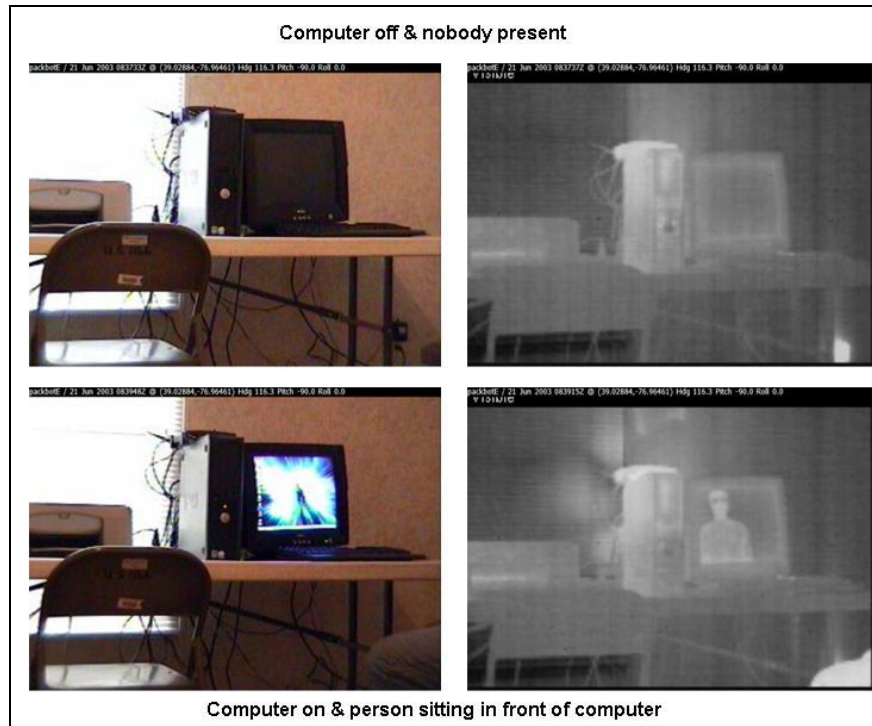

Figure 18. Computer scenario signatures.

- **Use of Cell Phone**

Cell phones are ubiquitous. Their use has gone up tremendously in recent years and they are being used for various purposes. It is highly useful to detect their usage in a confined area or in an urban area. Detection of usage of the cell phones obviously reveals the presence of a person and his/her activity.

- **Boiling Water on a Kettle**

The objective of this experiment was to see if there were any kettles and to determine if they had been used by somebody recently.

- **Use of Toaster and Microwave Oven**

The objective of this experiment was to see if there were any toasters or microwave ovens and to determine if they had been used by somebody recently.

- **Heat Floor Vent and Heat/A/C Intake**

The objective of this experiment was to determine if the vents in a building or a facility were blowing either cold or hot air. The thermal profiles of these could provide a clue as to the activity in or occupancy of the facility.

4.3 Data Collection in South Parking Lot Trailer

The data collection in the south parking lot trailer was primarily done for fine-tuning the algorithms for final demo purposes. The demo was done in the trailer enacting a office room scenario. There will be more on this when we discuss the demo.

5. Algorithm Development

Primarily the algorithm development for the HIDE ATO is partitioned into two main categories: (1) non-imaging sensor data processing and (2) imaging sensor data processing. In each one, the algorithm is further partitioned into (1) personnel activity detection and (2) machine activity detection, as shown in figure 19.

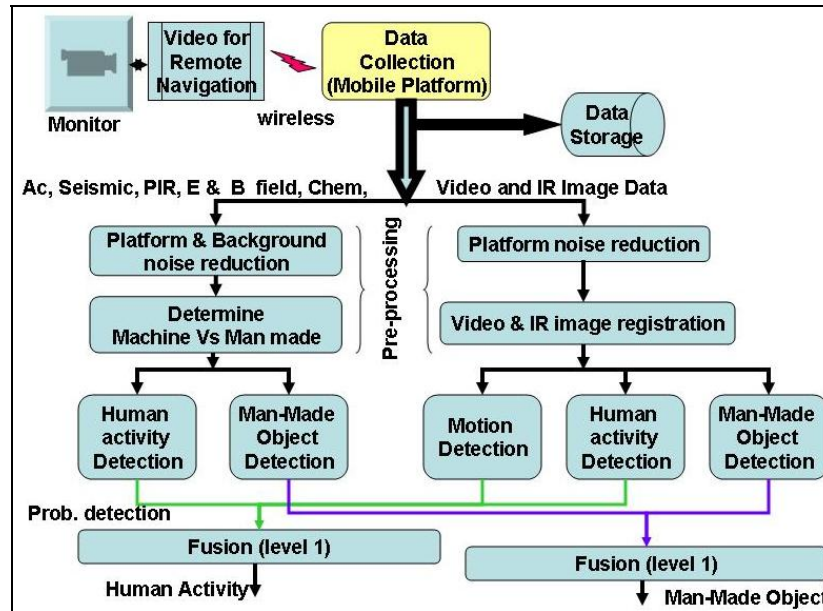

Figure 19. System flow chart for algorithm development.

The non-imaging sensors consist of acoustic, seismic, PIR, magnetic, and E-field sensors. We now present the algorithms for these sensors. As shown in figure 19, each algorithm is looking for human activity and manmade objects such a machine, kettle, etc.

5.1 Acoustic Algorithms

Personnel Detection

In order to detect the presence of people, we try and analyze the audio signatures. If people are talking, we capture their voice data and, based on the voice spectrum and their intensity levels, we determine whether there is a person or personnel present. Another way to determine the presence of people is to perform speech processing of the audio signals received. However, most

of the speech processing software available cater to only a few languages, which is an impediment. For this reason, we developed the personnel detection algorithm based on the energy contents in the voice spectrum of audio signatures. The description of the algorithm is as follows.

The algorithm first collects statistics with or without people present in the scene. The people are free to talk, walk, or simply be silent. We primarily concentrated in the frequency band between 1–2000 Hz for these statistics. Four different statistics were collected, one for each band, 1–500, 501–1000, 1001–1500, and 1501–2000 Hz. These statistics are estimated as follows: let $F^t = \{f_1^t, f_2^t, \dots, f_{2000}^t\}$ represent the amplitudes of the spectra of the acoustic signal at instant t , then the mean M_q^j of the spectral band is estimated as

$$s_{t,q} = \sum_{n=q+1}^{q+500} f_n^t, \quad \forall q \in \{0, 500, 1000, 1500\}$$

$$M_q^j = E\{s_{1,q}, s_{2,q}, \dots, s_{t,q}\}, \quad \forall q \in \{0, 500, 1000, 1500\}, j \in \{0, 1\}$$

$$\Sigma_q^j = \text{std. dev}\{s_{1,q}, s_{2,q}, \dots, s_{t,q}\}, \quad \forall q \in \{0, 500, 1000, 1500\}, j \in \{0, 1\}$$
(1)

where E denotes the expected value and *std. dev.* denotes standard deviation and $j=0$ corresponds to the case with no people present and $j=1$ corresponds to the case with people present. We have four means, $\{M_1^0, M_{500}^0, M_{1000}^0, M_{1500}^0\}$, corresponding to four bands and standard deviations $\{\text{std}_1^0, \text{std}_{500}^0, \text{std}_{1000}^0, \text{std}_{1500}^0\}$ for the case when no people were present in the scene. Similarly, we have the means and the standard deviations for the case when people are present. In general, M_q^j and Σ_q^j are the representatives of energy level in each band and their variances. Let us denote the energy levels in N bands as $X = \{X_1, X_2, \dots, X_N\}$, where X_i is the energy in band i , and we assume the energy levels in each band are statistically independent and have the Gaussian distribution given by

$$p(X_i) = \frac{1}{(2\pi)^{1/2} |\Sigma_i|^{1/2}} \exp\left\{-\frac{1}{2}(X_i - M_i)^T \Sigma^{-1}(X_i - M_i)\right\}$$
(2)

where M_i and Σ_i denote the mean and variance, respectively, and T denotes the transpose. Then the likelihood that a person is present or not is given by

$$p(X | H_j) = \prod_{i=1}^N p(X_i | H_j) p(H_j), \quad j = \{0, 1\}$$
(3)

where H_0 and H_1 are the hypotheses correspond to a person is not present and a person is present, respectively. Then the posterior probability of human presence is given by

$$p(H_1 | X) = \frac{\prod_{i=1}^N p(X_i | H_1) p(H_1)}{\prod_{i=1}^N p(X_i | H_0) p(H_0) + \prod_{i=1}^N p(X_i | H_1) p(H_1)}. \quad (4)$$

Assuming $p(H_0) = p(H_1) = 0.5$, we can compute the posterior probability of a human present given X . If it exceeds a particular threshold value, we declare that a human is detected. The algorithm is given below and detailed in figure 20.

Algorithm:

- Let $s(t)$ corresponds to 1-s data.
- $S = \text{fft}(s)$; is the fast Fourier transform (FFT) of the signal $s(t)$.
- Compute the mean and variances for each band using equation 1.
- Use equations 2 and 4 with appropriate means and variances for noise and statistics collected on people to compute the posterior probability, $p(H_1 | X)$.
- Use the posterior probability for fusion and declare that a person is detected if $p(H_1 | X) > 0.6$.

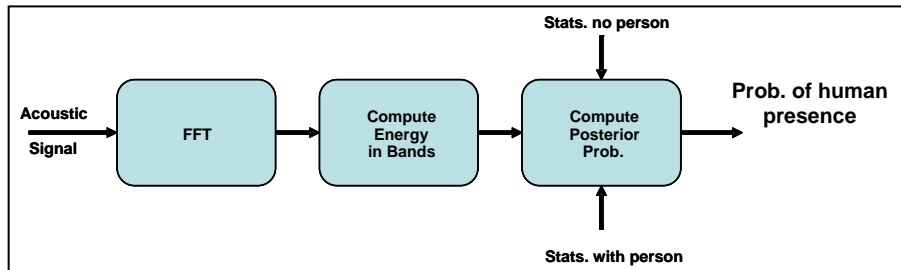

Figure 20. Block diagram for the acoustic detection algorithm.

Programming Aspect

To compute the posterior probability $p(H_1 | X)$, we used the “classify” function in MATLAB.

The function takes three inputs: (1) the vector that is to be classified, (2) the set of vectors corresponding to the cases with and without personnel present, and (3) the class of each vector in the second input. The function “classify” also gives the percentage of wrong classification—this information is used as the uncertainty parameter for fusion using Dempster-Shafer fusion algorithm, which we describe later. One can use several bands and their energy levels along with their statistics in the above algorithm to improve the classification. The algorithm is modular and can be expanded. We now consider the acoustic algorithm to determine the probability of a machine or machine activity.

Acoustic Algorithm for Manmade Object (Machine) Detection

The approach we took for detection of manmade objects using acoustic sensors was to determine the periodic signals in the acoustic data. The philosophy behind this is that most manmade objects perform repetitive operations resulting in fundamental frequency and its harmonics. So clearly, the algorithm looks for 50 Hz, 60 Hz, and their harmonics. In fact, it looks for any set of harmonics using harmonic line analysis. If two or more harmonics are present in acoustic data, then it is determined that a manmade object is present.

Cell Phone Ringing Detection

Here we performed the discrete cosine analysis of the acoustic signal and determined the frequencies associated with the ringing of cell phone. The presence of set of frequencies above certain threshold associated with the ringing tone determines cell phone detection. The algorithm was trained to determine these frequencies for several cell phone rings.

5.2 Seismic Detection Algorithms

Seismic Algorithm for Personnel Detection

The seismic sensor is used here to detect the footprints of a person walking by capturing the vibrations in the floor. A normal walk periodicity (cadence) of a person or gait frequency is around 2 Hz. Hence, several algorithms try to extract the gait frequency and its harmonics in the seismic sensor data. In order to detect the gait frequency, we used 6 s of data (sliding scale) and took its absolute value to make the envelope of the signal more predominant. We then took the FFT of the absolute signal (FFT of the envelope). If more than one person is present in the scene, the joint gait frequency may be different and might generate multiple harmonics. As a result we selected the amplitudes of the first 15 bins of FFT corresponding to 1–15 Hz. These 15 amplitudes became the feature vector. Just as in the case of acoustic detection algorithm, we assumed these features have the Gaussian distribution and used equation 3 for determining the $p(H_0 | X)$ and $p(H_1 | X)$ with appropriate mean and variance, which were then used in equation 4 to determine the posterior probability. Note in the case of seismic sensor, the N in equation 4 is 15. We used the posterior probability for fusion and declared that a person was detected if $p(H_1 | X) > 0.6$. Once again, we used the “classify” function in MATLAB to compute the posterior probabilities. Figure 21 details the seismic detection algorithm.

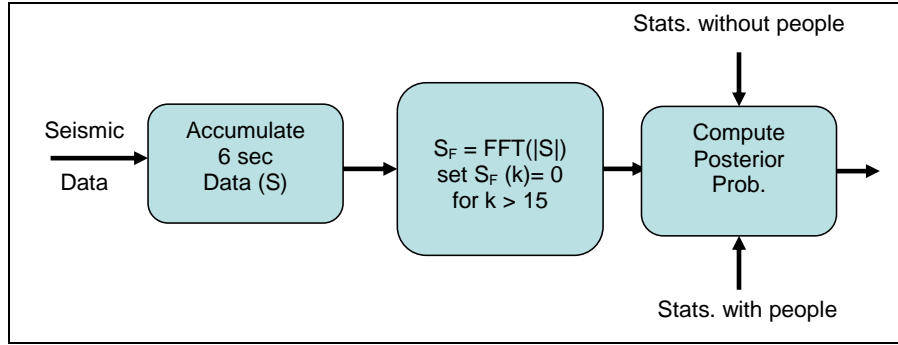

Figure 21. Seismic detection algorithm.

Seismic Algorithm for Manmade Object (Machine) Detection

As for the machine detection, once again we are trying to detect the harmonics in the signals that are closely related to the fundamental frequency of operation of the machine. Since the acoustic and seismic signals are very similar, we used the acoustic algorithm for manmade object detection for the seismic signals as well.

5.3 PIR Detection Algorithm for Personnel

PIR sensors are typically used as motion detector; however, the output of the sensor is proportional to the heat radiated by the body of a person or an object. As a result, when a person comes into the range of a PIR sensor, it generates an output. The PIR sensors used in this experiment were dual plate sensors, where one plate got positively charged and another got negatively charged. It was possible to determine the direction of a person walking based on the output of the sensor depending on whether the output changed from positive to negative or vice versa. Since we were only interested in detecting whether a person was present or not, we used a simple threshold detector. Since this detector was, in general, a very robust sensor, the probability of detection p was set to 1 if it exceeded a threshold of 0.3 V.

5.4 Magnetic Sensor Algorithms

There are two types of magnetic sensors used on the PackBot: the fluxgate magnetometer and the coil-type magnetometer. The fluxgate magnetometer is a low frequency (10 samples per second) and the coil type has a sampling rate of 256 samples per second. Due to their limited bandwidth, we could not find any features in the frequency domain, except the 60 Hz hum in the data of coil-type magnetometer. The algorithm was developed for detection of magnetic material movement or change in the flux due to electrical activity in the vicinity of the sensor is a threshold detector. For this, the baseline noise-floor was established by collecting the ambient data prior to the experimentation for several minutes. A threshold of 0.3 V was used above the noise floor for detection purposes.

5.5 E-field Sensor Algorithms

For the limited experiments we conducted, we could not find the phenomenology based feature set in the frequency domain for personnel and manmade object detection. Just as in the case of magnetic sensor algorithms, we used a threshold detector for the E-field sensor as the algorithm for detection of anomaly in the E-field due to the presence of a person or machine activity.

5.6 Video Motion Detection Algorithm for Personnel Detection

Another sensor used was a video camera to detect the presence of personnel. This was done by detecting a moving body in the video frames. The camera captured the scene in its FOV frame by frame every second. For motion detection, the current frame was compared to the previous frame. Timestamps at the bottom of the image were removed before this comparison. The images were then subtracted from each other on a pixel-by-pixel basis to find the difference. The resulting difference “image” was filtered for noise. First, any small difference values were removed (set to 0). The difference image then underwent median filtering, which removed the small elements of noise/illumination changes. Median filtering works by making each pixel equal to the median of the pixels within a small area. The small area is defined by a structural element, which for this algorithm was a 4 x 4 neighborhood. The total variance of the resulting image is computed, and if it exceeds a threshold, motion is detected. Whenever a motion was detected by the motion detection algorithm, the probability of detection of personnel was assigned a value of 1, the probability of no detection and uncertainty were assigned a value of zero.

5.7 Video Detection Algorithms for Thermal Profiling

One of the aims for the HIDE ATO was to determine if an object such as a chair had been used recently, if so how long ago the chair had been used. In order to do this, the algorithm had to go through several steps.

- Is it a manmade object?
- Registration of the video and IR images
- Detection of thermal decay rate
- We will address these issues one by one.

Manmade Object Detection Using Video Frames

Manmade objects often have geometric shapes such as circles, triangles, squares, etc., in their shape. So one natural approach is to detect these shapes in the video frame and identify all the shapes that fit geometrical shapes and based on the number of such shapes in the frame and the total occupancy of the shape in the object of investigation, one can determine the probability of manmade objects present in the video frame.

We felt that manmade object detection in a video frame is highly time consuming and unnecessarily ties up resources for development of this algorithm. There may be commercially available software for detection of manmade objects that can be used.

Registration of Video and IR Images

This is an essential step that must be performed to determine if a manmade object is hot and has been recently used. We used a standard registration technique used in image processing for this. Figure 22 shows the image of chairs captured by video and IR cameras before and after registration.

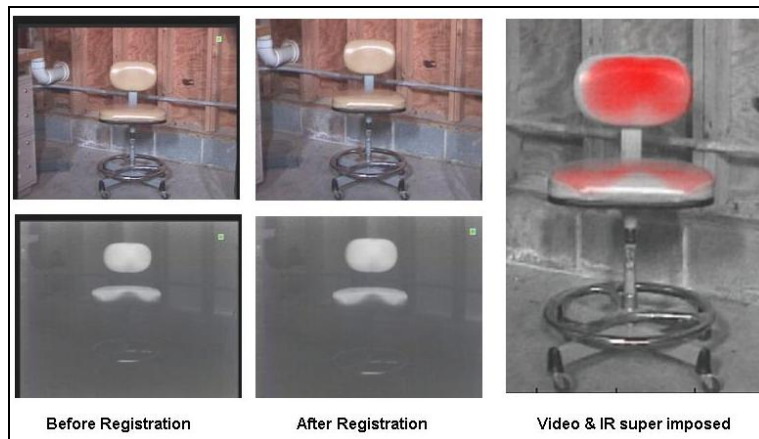

Figure 22. Registration of video and IR images.

Thermal Profiling

For this, we monitor the hot surface (in the above example, a chair) and determine the intensity level of the heat with time. This was done for various metallic as well as plastic objects. We developed a set of thermal profile curves for various targets, which gave the time elapsed from the time the object was last used.

5.8 Personnel Detection using IR Imager

Thermal image in figure 18 shows a thermal image of the person in front of the computer due to reflection. Most of the thermal energy radiated by the person in front of the computer monitor is reflected by the monitor and this reflected thermal energy was detected by the IR imager. The IR imager algorithm processed the silhouette reflected from the monitor. First, a Hough transform (12) was used to determine the line patterns of an object, and then using elliptical and rectangular models to detect a person (13–15) in front of the monitor provided the probability of a person being present in the room. Figure 23 shows the sequence of operations and the resulting images from the algorithm. In order to determine the extracted reflected image is a silhouette of a person, we extracted the dimensions of head, neck, and torso. For a person the ratio of head width to height is ~ 1.2 , similarly the ratios between neck width and head height and the neck width to torso width are used to determine the probability of a person.

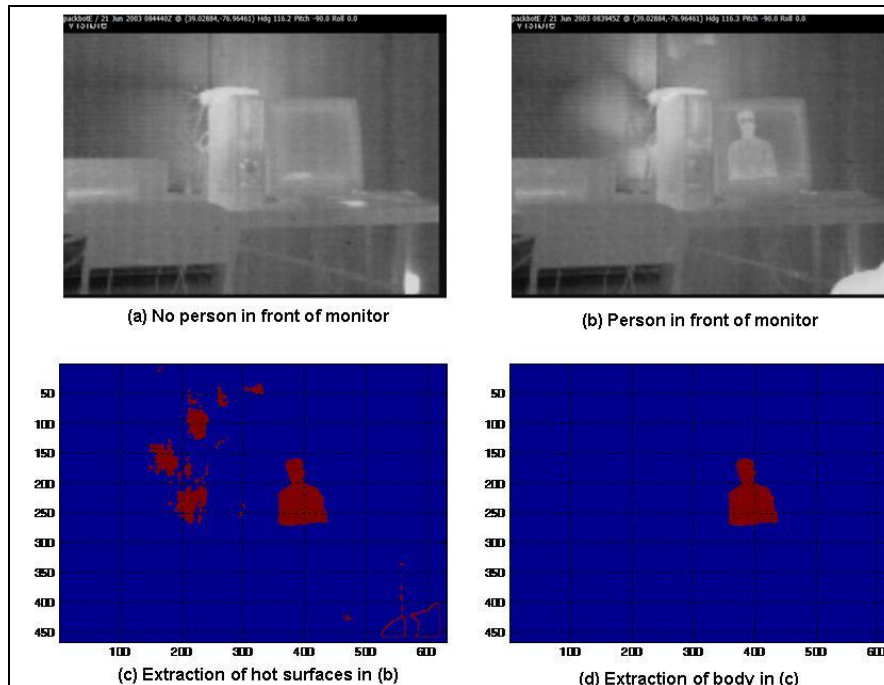

Figure 23. (a) Thermal image of the monitor without a person in front, (b) a person in front of the monitor, (c) the hot surfaces extracted from the image (b), and (d) a silhouette of a person extracted from (c).

6. PackBot Platform Effect on Sensor Data and Processing

As mentioned previously, acoustic, seismic, PIR, magnetic field, E-field, chemical, video, and infrared image sensors were installed on the PackBot (a small robot). There were several constraints on the platform for integrating these sensor modalities on a small PackBot. First and foremost was the real estate on the PackBot available for mounting the sensors. In order to mount all the sensors, we had to install an additional platform on the PackBot. Another big concern was the use of power. In order to save the real estate on the PackBot for the sensors and the data collection unit, we decided to use the existing batteries that power the PackBot to power the sensors and the data collection unit. This helped to minimize the weight that would have otherwise increased if we had had to mount additional batteries to power the sensors and the data collection unit. The data collection unit had a limited number of channels and the data rates were selected based on the sensors.

Another big concern was interference between sensors. For example, the chemical sensor had a fan to suck in the air that flows over the sensor module that reacts with the chemicals present in the air. The fan noise appeared in most of the sensor data. As the fan motor rotates, it generates E- and B-field noise, which showed up in the respective modalities.

In this section, data from several modalities is analyzed and the noise from the platform and other sensors are identified. We present some of the techniques used to mitigate the noise due to the platform and other interfering sensors prior to applying the personnel detection algorithms. We found that the mobile platform we used produced significant noise while in motion. This noise sometimes saturated the sensors. As a result, the data were collected mainly while the mobile platform was stationary. However, there were other noises due to interfering sensors, power lines, and the platform itself. Analysis of the data is shown for all the sensors on the mobile platform (the acoustic, seismic, PIR, and B- and E- field sensors). Video and IR imaging sensor data were found to be free of interference.

Acoustic Sensor Data Analysis

Due to the close proximity of acoustic sensor to other sensors, the data collected using the acoustic sensor contained several interferers that were predominant. For example, some of the noise sources were due to the chemical sensor's fan noise, power line hum, and the mobile platform itself. In order to identify the frequencies of interference, we collected data using acoustic sensor for several minutes at 16 K sampling rate and performed FFT on the data and computed the average spectrum of the data shown in figure 24. From figure 24, the fan noise is very predominant followed by the 60 and 120 Hz hum due to the transformers on the nearby fluorescent lamps that operate at 60 Hz. The mobile platform (PackBot) itself had some inherent noise source at 14 Hz. These frequencies were filtered out using a bank of notch filters and the average spectrum after filtering the noise is shown in figure 24. Clearly, the noises are reduced significantly and the data can be processed for personnel detection or acoustic event.

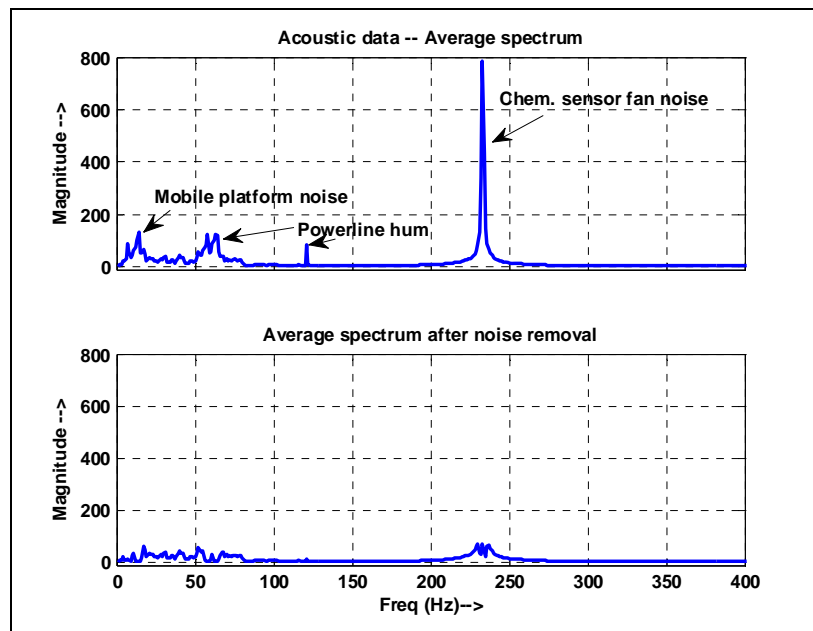

Figure 24. Acoustic data spectrum before and after noise removal.

Figure 25 shows the flow chart for the acoustic signal processing. The notch filter box consists of several notch filters at 60, 120, 230, 460, 690, and 920 Hz.

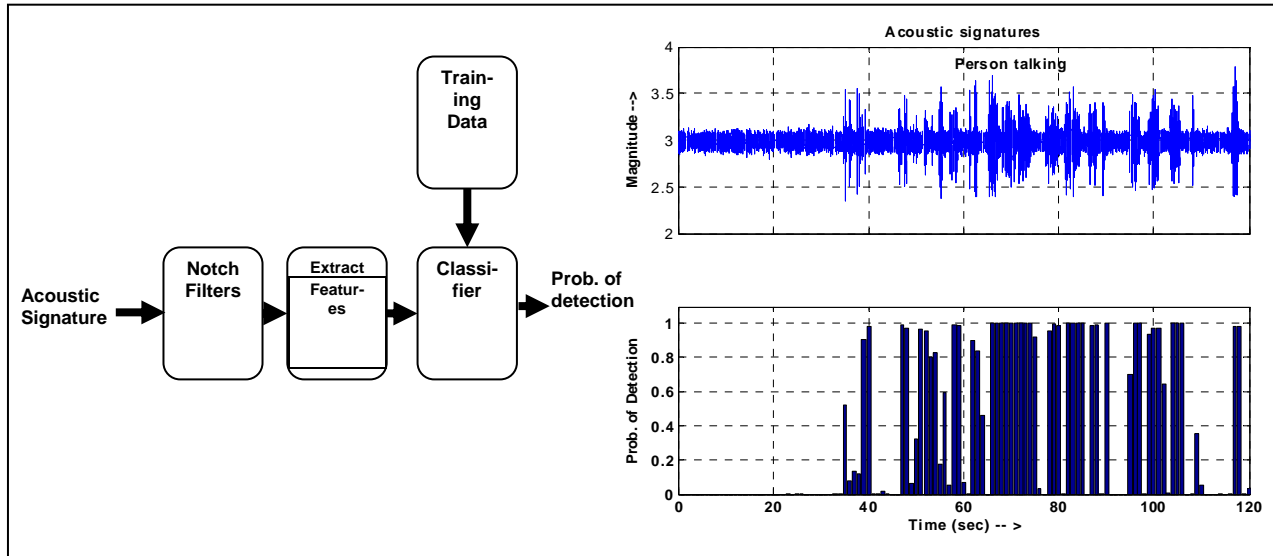

Figure 25. (a) Block diagram for acoustic data processing and (b) acoustic signal and probability of detection.

Seismic Sensor Data Analysis

Seismic data were also collected at 16 K sampling rate. We found that the fan noise was also present in the seismic sensor data. Figure 26 shows the average spectrum of the seismic data before and after noise removal.

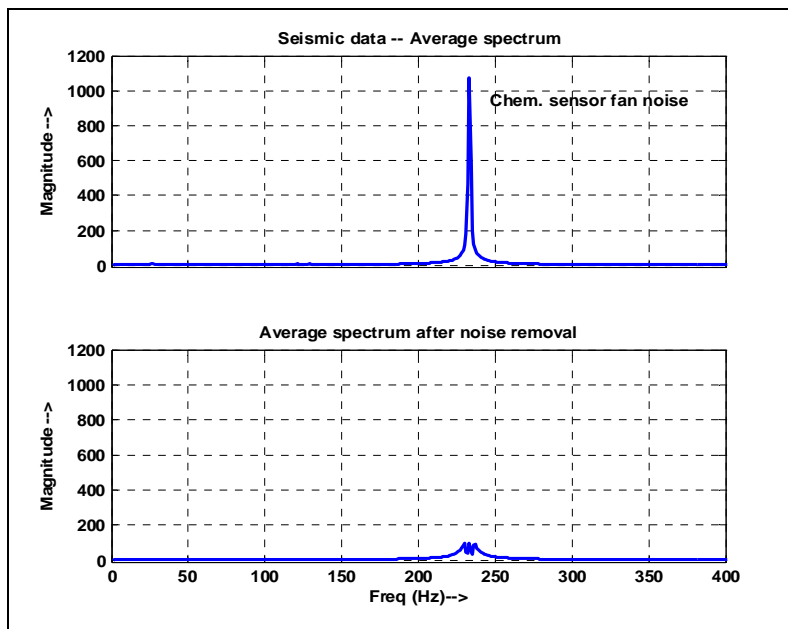

Figure 26. Seismic data spectrum before and after noise removal.

We used the algorithm described in section 6.2 for seismic sensor data for detection of people. Figure 27 shows the results of the algorithm for personnel detection.

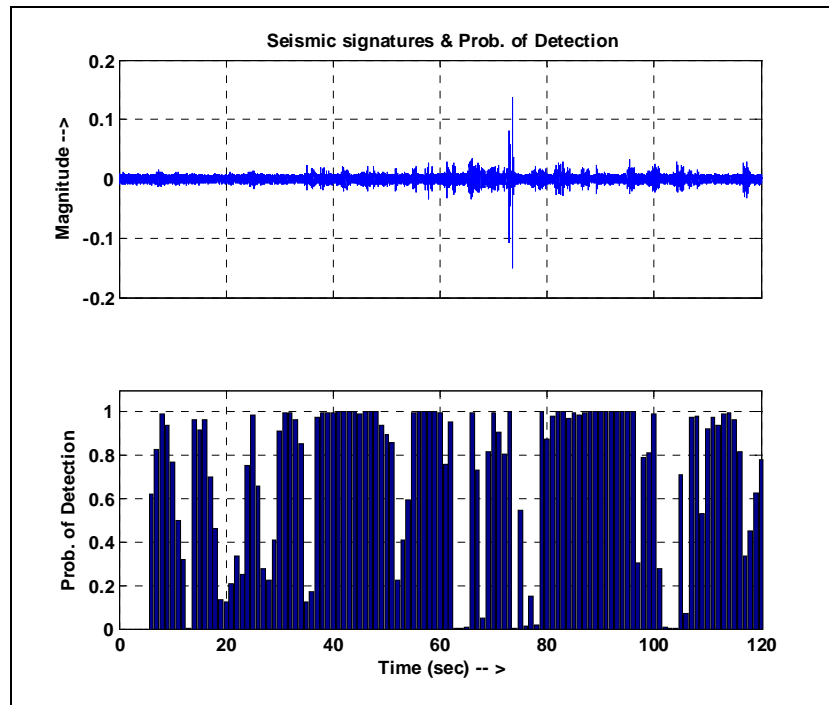

Figure 27. Seismic signatures and probability of detection.

PIR Sensor Data Analysis

This is a motion detector with 30° FOV lens. The data were collected at 256 samples per second. Since the bandwidth was 128 Hz, the fan noise (~230 Hz), which we saw in both acoustic and seismic sensors, was not predominant in the PIR data. Just as mentioned in section 6.3, we used a threshold detector for detecting moving objects. Figure 28 shows the output of the algorithm.

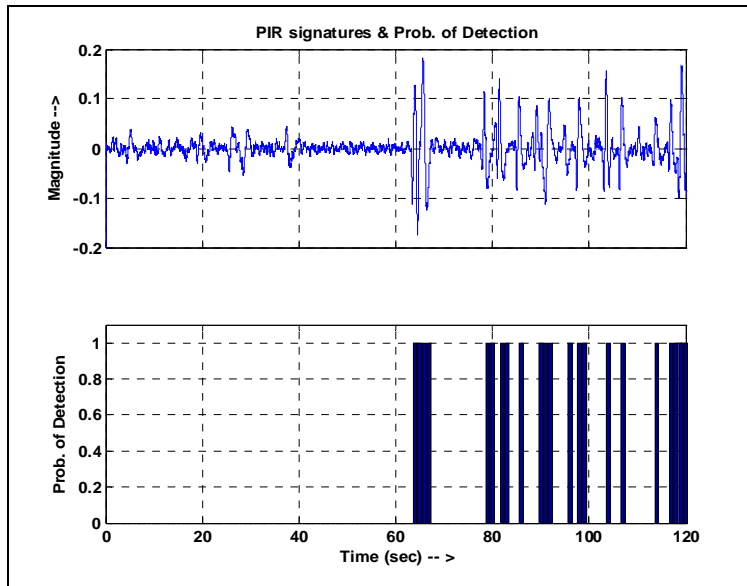

Figure 28. PIR signatures and probability of detection.

E-field Sensor Data Analysis

E-field sensor data were collected at 8 K sampling rate. The harmonics of fan noise were more predominant in E-field data compared to other modalities. Figure 29 shows the average spectrum before and after noise removal. Notice there is still some residual noise signals due to fan harmonics are left in the average spectrum of the seismic data. This is due to the fact that the fan noise frequency was changing with time as the battery power is changing due to operation. So the notch filters designed at specific average frequencies could eliminate some but not all the noise due to the fan.

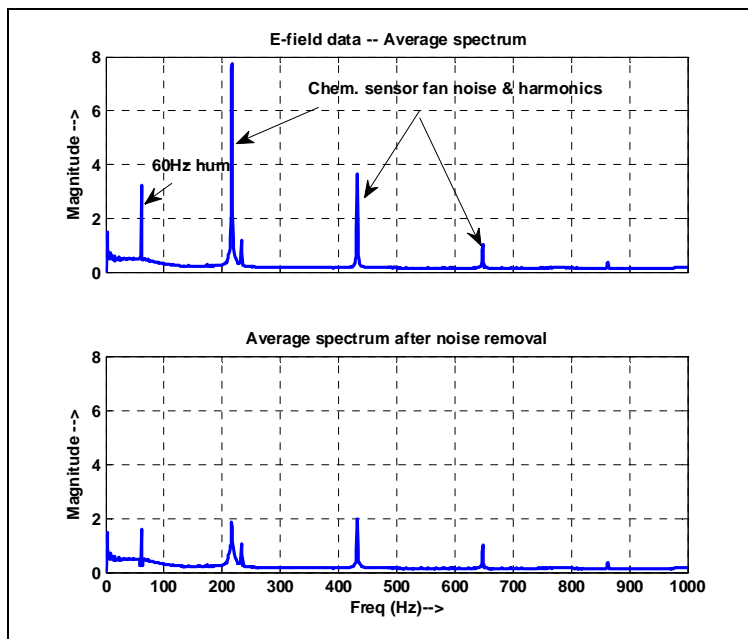

Figure 29. E-field data spectrum before and after noise removal.

The E-field algorithm is a threshold detector and its results for the data are shown in figure 30.

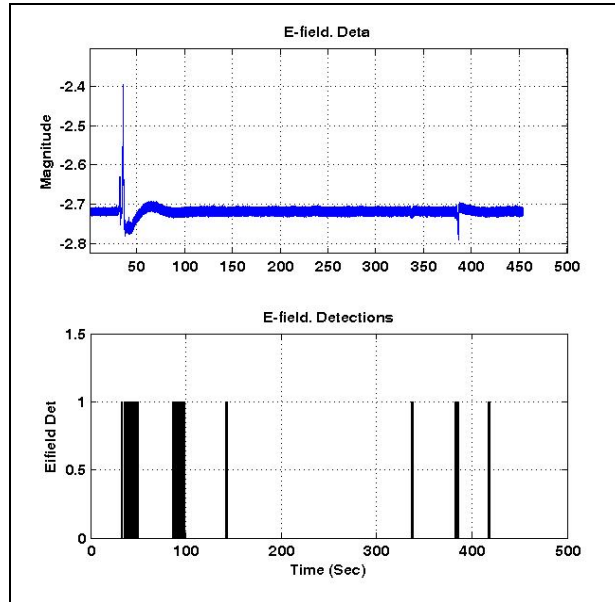

Figure 30. E-field data and detections by the algorithm.

B-field Sensor Data Analysis

These data were collected at 256 samples per second; as a result the 230 Hz noise due to fan noise was not predominant in the B-field data.

Once most of the noise is removed from the data using several notch filters, it is processed for personnel detection.

The B-field algorithm is a threshold detector and its results for the data are shown in figure 31.

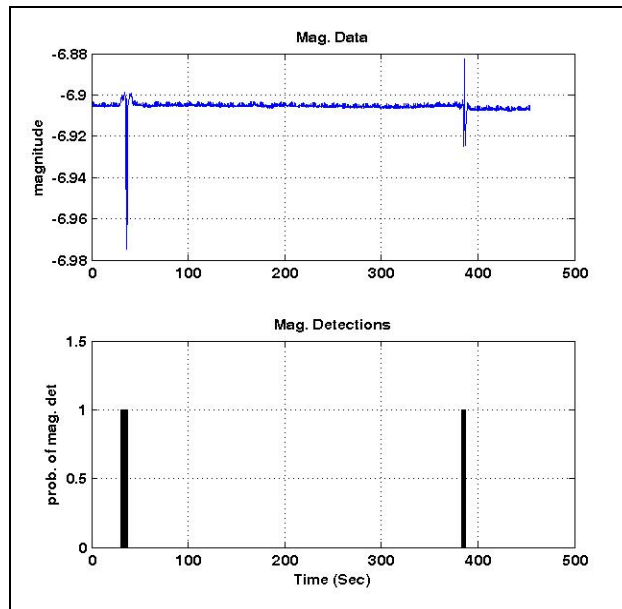

Figure 31. Magnetic field data and detection by the algorithm.

7. Sensor Fusion

Sensor fusion is supposed to lead to a better situational awareness. However fusion of multimodal data is a difficult thing to do as few joint probability density functions for mixed modalities exist. Fusion mostly depends on the application at hand. The problem is further complicated if one has to fuse the events that take place over a period of time and over a wide area for situational awareness. If they are time dependent, the relevance of the data observed at different times becomes an issue. We opted to do a fusion of information (decision – probability of detection of an event). In a majority of the cases, Bayesian networks (4, 5) were used for fusion. In this report, we use Dempster-Shafer fusion (6, 7) for fusion of multimodal multi-sensor data.

So far we have shown individual algorithms for individual sensors such as acoustic, seismic, PIR, B- and E-field sensors, and video and IR imagers. Each sensor is geared to detect whether a person is present in the vicinity or not and also determines whether any manmade objects are present. As shown in figure 19, the data from non-imaging sensors are fused in the fusion engine. Fusion can be done either at data level, feature level, or information level. We opted to perform the fusion at information level. The information each sensor algorithm puts out is the probability of detection p_d and all the p_d 's from individual sensors need to be fused to come up with an overall probability of detection for personnel and similarly another p_d for manmade object detection.

We used Dempster-Shafer fusion paradigm for fusing the information from various sensors. Dempster-Shafer's method involves probability masses given by sensors to be distributed over a set. In this implementation, the set used is {A, B, AB}. "A" represents the evidence for detection, "B" represents the evidence against detection, and "AB" represents the uncertainty or ignorance of the sensor.

Generally, with this scenario, the lack of evidence for detection does not signify that there is no person. For example, the acoustic sensor may not pick up anything if the target is intentionally being stealthy (not talking). To determine the uncertainty of a sensor, we compute the percentage of misclassification of training data by each detection algorithm and use it as the uncertainty for that sensor. We also adjust the probability of detection and probability of no detection appropriately so that the sum total of probability of detection, probability of no detection and the uncertainty equals 1.

Dempster-Shafer Rule of Combination

Let S_1 and S_2 denote two different sensors observing the presence of a person in their vicinity. The total probability mass committed to an event Z defined by the combination of evidence represented by $S_1(X)$ and $S_2(Y)$ is given by

$$S_{1,2}(Z) = S_1(Z) \oplus S_2(Z) = K \sum_{X \cap Y = Z} S_1(X) S_2(Y) \quad (5)$$

where K , the normalization factor is:

$$K^{-1} = 1 - \sum_{X \cap Y = \phi} S_1(X) S_2(Y) \quad (6)$$

This is basically the sum of elements from the set of Sensor 1 who intersect with Sensor 2 to make Z , divided by 1- the sum of elements from S_1 that have no intersection with S_2 .

The rule is used to combine all three probabilities (A, B, AB) of sensors S_1 and S_2 . The resultant probabilities are combined with the probabilities of the next sensor.

We used the acoustic, seismic, PIR, and video motion detection algorithms to detect the presence of personnel and computed the probability of detection, probability of no detection and probability of uncertainty for each sensor modality for the data. Figure 32 shows the probability of detection for all the four acoustic sensors on the PackBot and the result of the fusion using only acoustic sensors data. From figure 32, it is clear that the overall probability of detection has improved with fusion.

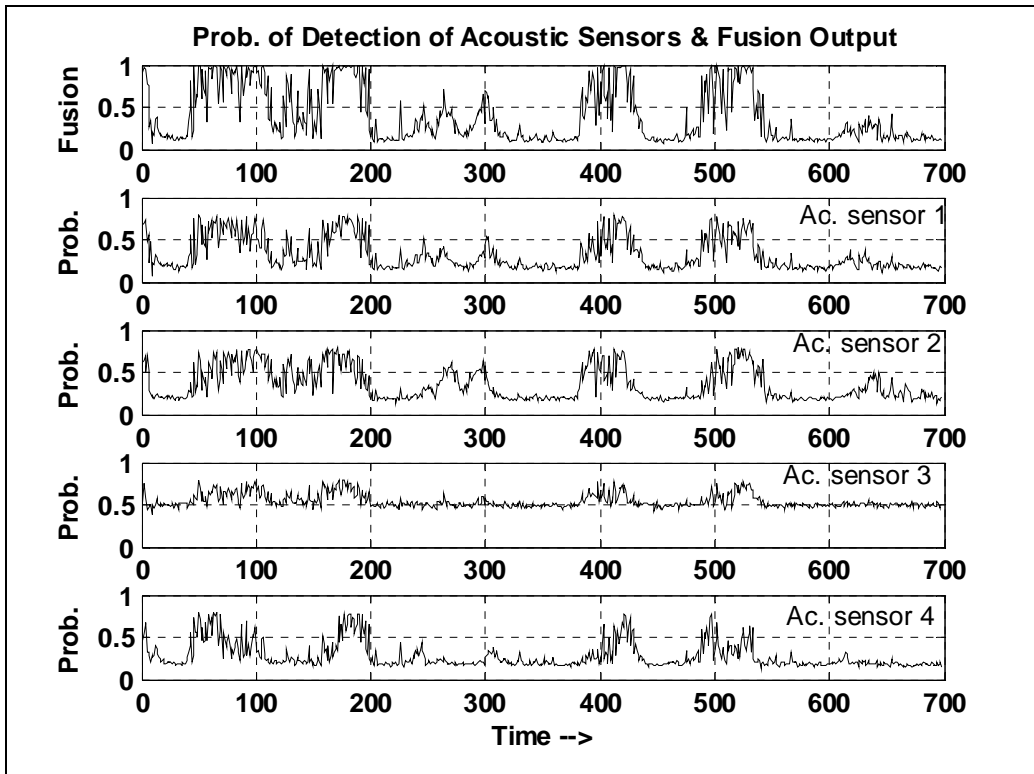

Figure 32. Results of fusion using acoustic sensors.

In figure 33 we show the results of fusion of acoustic and seismic data. Seismic sensor detects the footprints of a person. From figure 33 we notice around the 300-s time period the seismic sensor has high probability of detection compared to the acoustic sensors. This is the case where the people were not talking and hence had a low probability of detection. We also notice that the overall probability of detection after fusion is improved. Figure 34 shows the detections by individual sensor modality. As expected, the detections by the seismic sensor are minimum compared to other modalities. Reliable detections are obtained using PIR and video sensors. Acoustic sensors work best when some people are conversing.

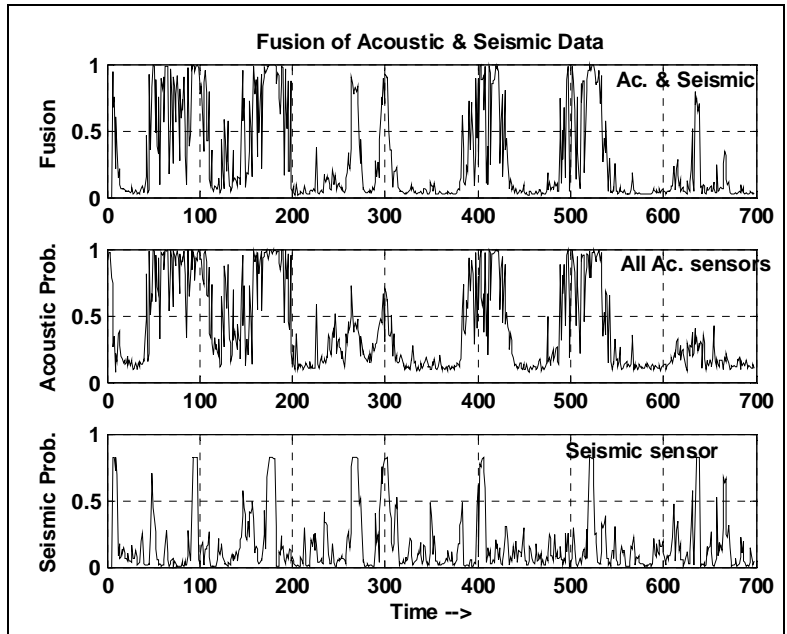

Figure 33. Probability of detection using acoustic and seismic data.

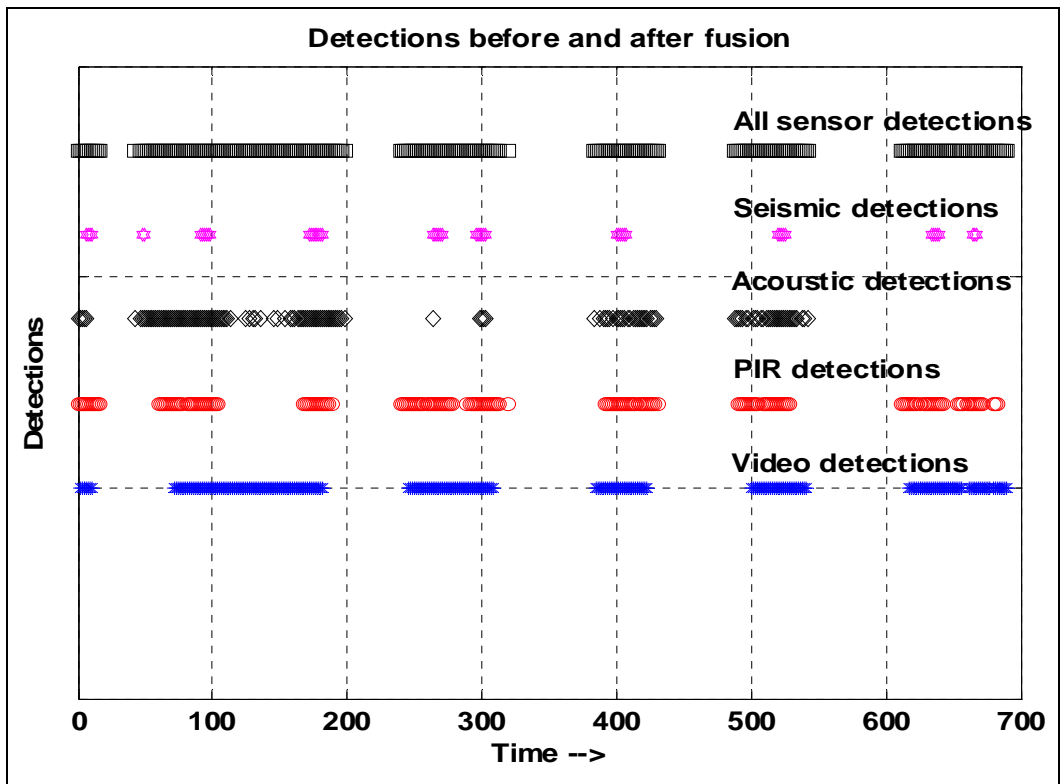

Figure 34. Detection before and after fusion.

8. Capstone Demo

In a situation where we are monitoring a building, we would like to know if there is any activity taking place. In particular, we placed a robot inside an office room (in stealth mode, various sensors will be placed and camouflaged to avoid detection), as shown in figure 35. Figure 35 also shows the robot with all the sensors. The goal is to assess the situation based on the observations of various sensor modalities over a period of time in the area covered by the sensor range. We enacted the data collection scenario with several features built-in to observe the happenings inside the office room and assess the situation.

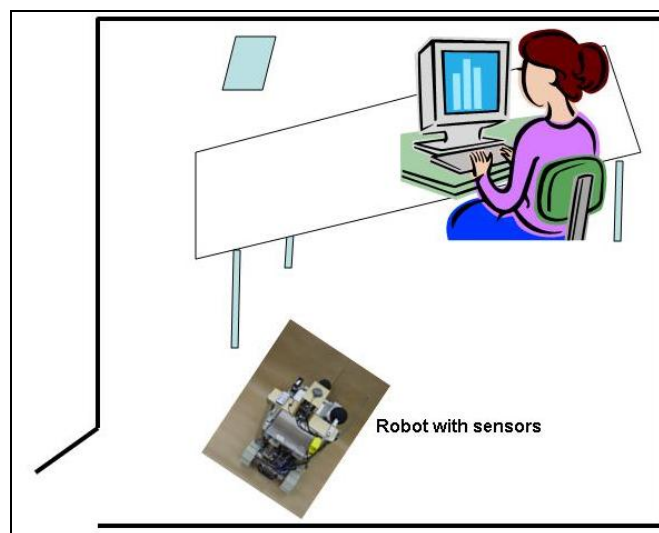

Figure 35. Demo scenario.

Demo Scenario

- A person walks into the office room—this triggers the PIR, B- and E-field, and seismic sensors.
- She occasionally talks—the acoustic sensor picks up the voice.
- She sits in front of a computer.
- She turns on the computer.
 - B- and E-field sensors observe the power surge caused by turning on the computer.
 - Acoustic sensors observe the characteristic chime of Windows turning on.
 - The person's movements are picked up by the PIR sensor.

- Visible video shows a pattern on the computer screen showing activity on the computer.
- The IR imager picks up the reflected thermal profile of the person in front of the monitor.
- She types on the keyboard—sound is detected by the acoustic sensor.
- She turns off the computer.
 - Windows turning off sound is observed by the acoustic sensor.
 - The power surge after shutdown is observed by the B-field sensor.

The above mentioned demo scenario was enacted and demonstrated the capabilities of the HIDE ATO algorithm suite.

9. Publication from HIDE ATO Work

1. Damarla, T.; Kaplan, L.; Chan, A. Human Infrastructure & Human Activity Detection. *Proceedings of the International Society for Information Fusion (ISIF)*, Quebec City, Quebec, Canada, 2007.
2. Damarla, T. Hidden Markov Model as a Framework for Situational Awareness. *Proceedings of the International Society for Information Fusion (ISIF)*, Cologne, Germany, 2008.
3. Damarla, T. Performance of sensors mounted on a robotic platform for personnel detection. *Proceedings of SPIE*, Orlando, FL, 2008.
4. Damarla, T; Ufford, D. Personnel Detection using Ground Sensors. *Proceedings of SPIE*, Orlando, FL, 2007.
5. Damarla, R.; Fine, J.; Thielke, M.; Chatters, G.; O'Brien, B.; Fischer, G. Lessons learned in using UGS on a robotic platform for human infrastructure & activity detection. *Proceedings of MSS BAMS*, Laurel, MD, 2008.
6. Thielke, M.; O'Brian, B.; Chatters, G.; Fine, J.; Samples, G.; Houser, J.; Damarla, R. Experiments for Human Infrastructure Detection and Exploitation at Center for National Response. *Proceedings of MSS BAMS*, Laurel, MD, 2008.
7. Damarla, T.; Thielke, M.; Vinci, S.; Fine, J.; Samples, G.; Fisher, G.; Chatters, G. Experiments and Partial Results on Detection of Human Infrastructure and Activity. *Proceedings of MSS BAMS*, Laurel, MD, 2007.

10. References

1. Damarla, T. R. et al. Personnel Detection Algorithm for Disposable Sensors Using Multi Sensor Data. *Proc. MSS Battlefield Acoustic & Magnetic Sensing Symposium*, Laurel, Maryland, 2005.
2. Houston, K. M.; McGaffigan, D. P. Spectrum Analysis Techniques for Personnel Detection Using Seismic Sensors. *Proc. of SPIE* **2003**, 5090, 162–173.
3. Hall, D. L.; Llinas, J. *Handbook of Multisensor Data Fusion*, CRC Press Boca Raton, FL, 2001.
4. Klein, L. A. *Sensor and Data Fusion – A Tool for Information Assessment and Decision Making*, SPIE Press, Bellingham, WA, 2004.
5. Damarla, T. Raju; et al. Personnel Detection Algorithm for Disposable Sensors Using Multi Sensor Data. *Proc. MSS Battlefield Acoustic & Magnetic Sensing Symposium*, Laurel, MD, 2005.
6. Cathcart, J. M. Phenomenological investigations Into Personnel Signatures. *Proc. of the SPIE* **May 2005**, 5796, 428–434.
7. Mauro, B.; Cathcart, J. M. Analysis of Visible Band Sensors for Personnel Detection. *Proc. of SPIE* **2006**, 6231, 62310D-1–62310D-12.
8. Edelstein, Alan; Dammann, Jeff; Riordan, Pat. Locating IEDs Using Magnetic Sensors & Tracking Algorithm Using a Single Vector Magnetomete. *Proc. MSS Battlefield Acoustic & Magnetic Sensing Symposium*, Laurel, MD, August 2005.
9. Ma, W.; Manjunath, B. S. Edge Flow A Technique for Boundary Detection and Image Segmentation. *IEEE Trans. Image Processing* **Aug. 2000**, 9 (8), 1375–1388.
10. Haddan, J. F.; Boyce, J. F. Image Segmentation by Unifying Region and Boundary Information. *IEEE Trans. Pattern Analysis Machine Intelligence* **Oct. 1990**, 12 (10), 929–948.
11. Brown, L. G. A Survey of Image Registration Techniques. *ACM Computing Surveys* **Dec. 1992**, 24 (4), 325–376.
12. Irani, M.; Anandan, P. A Unified Approach to Moving Object Detection in 2D and 3D Scenes. *IEEE Trans. on Pattern Analysis and Machine Intelligence* **June 1998**, 20 (6), 577–589.

13. Irani, M.; Rousso, B.; Peleg, S. Recovery of Ego-motion Using Regional Alignment. *IEEE Trans. on Pattern Analysis and Machine Intelligence* **Mar. 1997**, 19 (3), 268–272.
14. Nixon, M. S.; Chellappa, R.; Tan, T. *Human Identification Based on Gait*, Springer: New York, 2006.
15. Mandelbrot, B. B. *The Fractal Geometry of Nature*, San Francisco Freeman, 1982.
16. Mokhtarian, F. Silhouette-Based Isolated Object Recognition through Curvature Scale Space. *IEEE Trans. on Pattern Analysis and Machine Intelligence* **May 1995**, 17 (5), 539–544.

List of Symbols, Abbreviations, and Acronyms

ARL	U.S. Army Research Laboratory
ATO	Army Technology Objective
C2CUT	Command & Control for Complex & Urban Terrain
CERDEC	Communications-Electronics Research Development and Engineering Center
CNR	Center for National Response
E-field	electrostatic-field
FFT	fast Fourier transform
FOV	field of view
FY	fiscal year
GPS	Global Position System
HIDE	Human Infrastructure Detection and Exploitation
HMDC	Hyper Modal Data Collector
I2WD	Intelligence and Information Warfare Director/Directorate
ISR	Intelligence, Surveillance, and Reconnaissance
MURI	Multi-University Research Initiative
PIR	passive infrared
QFS	Quasar Federal Systems
RF	radio frequency
STTW	Suite of Sense-Through-The Wall
TSF	Training Support Facility
UGV	Unmanned Ground Vehicle
USSOCOM	United States Special Operations Command
VPS	Virtual Perimeter Security

<u>NO. OF COPIES</u>	<u>ORGANIZATION</u>
1 ELEC	ADMNSTR DEFNS TECHL INFO CTR ATTN DTIC OCP 8725 JOHN J KINGMAN RD STE 0944 FT BELVOIR VA 22060-6218
1	DARPA ATTN IXO S WELBY 3701 N FAIRFAX DR ARLINGTON VA 22203-1714
1 CD	OFC OF THE SECY OF DEFNS ATTN ODDRE (R&AT) THE PENTAGON WASHINGTON DC 20301-3080
1	US ARMY INFO SYS ENGRG CMND ATTN AMSEL IE TD A RIVERA FT HUACHUCA AZ 85613-5300
1	COMMANDER US ARMY RDECOM ATTN AMSRD AMR W C MCCORKLE 5400 FOWLER RD REDSTONE ARSENAL AL 35898-5000
1	US ARMY RSRCH LAB ATTN RDRL CIM G T LANDFRIED BLDG 4600 ABERDEEN PROVING GROUND MD 21005-5066

<u>NO. OF COPIES</u>	<u>ORGANIZATION</u>
3	US ARMY RSRCH LAB ATTN IMNE ALC HRR MAIL & RECORDS MGMT ATTN RDRL CIM L TECHL LIB ATTN RDRL CIM P TECHL PUB ADELPHI MD 20783-1197
15	US ARMY RSRCH LAB ATTN RDRL CII A B O'BRIEN R GREGORY ATTN RDRL SEE P GILLESPIE ATTN RDRL SEE I D BEEKMAN ATTN RDRL SES M PATTERSON ATTN RDRL SES A G CHATTERS J HOUSER R DAMARLA ATTN RDRL SES E ALEX CHAN G SAMPLES M THIELKE ATTN RDRL SES P A EDELSTEIN G FISCHER J FINE S VINCI ADELPHI MD 20783-1197
2	CERDEC ATTN I2WD M PELLICANO R FORESTA FT MONMOUTH NJ 07703

TOTAL: 26 (1 ELEC, 1 CD, 24 HCS)

INTENTIONALLY LEFT BLANK.