

# PRECISE SYNCHRONIZATION OF PHASOR MEASUREMENTS IN ELECTRIC POWER SYSTEMS

Dr. A.G. Phadke  
Virginia Polytechnic Institute and State University  
Blacksburg, Virginia 24061-0111, U.S.A.

## Abstract

*Phasors representing positive sequence voltages and currents in a power network are the most important parameters in several monitoring, control, and protection functions in inter-connected electric power networks. Recent advances in computer relaying have led to very efficient and accurate phasor measurement systems. When the phasors to be measured are separated by hundreds of miles, it becomes necessary to synchronize the measurement processes, so that a consistent description of the state of the power system can be established. GPS transmissions offer an ideal source for synchronization of phasor measurements. The paper describes the concept and implementation of this technique. Several uses of synchronized phasor measurements are also described. Among these are improved state estimation algorithms, state estimator enhancements, dynamic state estimates, improved control techniques, and improved protection concepts.*

## INTRODUCTION

Computer relaying is a well established field by now, and it has furnished a new insight into the technique of measuring power system quantities in real-time from sampled data. Voltage and current phasors in a three phase power system can be measured from waveform samples, and the measurement process can be made to be responsive to dynamically changing system conditions. For many new applications of phasor measurements now under consideration, measurement response times of 1-5 periods of the power frequency seem desirable. This paper will examine the concept of phasor measurements, and describe some practical considerations in achieving synchronous sampling of currents and voltages in different substations in a power system. We will also describe research now under way in the development of a phasor based protection and control system.

## PHASORS FROM SAMPLED DATA

A phasor is a complex number which represents the fundamental frequency component of a waveform. Consider the samples  $x_k$  obtained from a signal (voltage or current)  $x(t)$ . The phasor representation of the signal  $x(t)$  is related to the fundamental frequency component calculated by the Discrete Fourier Transform (DFT). If the phasor is  $X$ , and the fundamental frequency calculated by the DFT is  $X_1$ , then

$$X = \frac{1}{\sqrt{2}} X_1 = \frac{1}{\sqrt{2}} \frac{2}{K} \sum_{k=1}^K x_k e^{-jk\omega\Delta t} \quad (1)$$

where  $K$  is the total number of samples (usually a multiple of the fundamental frequency period), and  $\Delta t$  is the sampling interval. One could drop the constant in front of the

# Report Documentation Page

Form Approved  
OMB No. 0704-0188

Public reporting burden for the collection of information is estimated to average 1 hour per response, including the time for reviewing instructions, searching existing data sources, gathering and maintaining the data needed, and completing and reviewing the collection of information. Send comments regarding this burden estimate or any other aspect of this collection of information, including suggestions for reducing this burden, to Washington Headquarters Services, Directorate for Information Operations and Reports, 1215 Jefferson Davis Highway, Suite 1204, Arlington VA 22202-4302. Respondents should be aware that notwithstanding any other provision of law, no person shall be subject to a penalty for failing to comply with a collection of information if it does not display a currently valid OMB control number.

1. REPORT DATE <b>DEC 1990</b>		2. REPORT TYPE		3. DATES COVERED <b>00-00-1990 to 00-00-1990</b>	
4. TITLE AND SUBTITLE <b>Precise Synchronization of Phasor Measurements in Electric Power Systems</b>				5a. CONTRACT NUMBER	
				5b. GRANT NUMBER	
				5c. PROGRAM ELEMENT NUMBER	
6. AUTHOR(S)				5d. PROJECT NUMBER	
				5e. TASK NUMBER	
				5f. WORK UNIT NUMBER	
7. PERFORMING ORGANIZATION NAME(S) AND ADDRESS(ES) <b>Virginia Polytechnic Institute and State University, Blacksburg, VA, 24061-0111</b>				8. PERFORMING ORGANIZATION REPORT NUMBER	
9. SPONSORING/MONITORING AGENCY NAME(S) AND ADDRESS(ES)				10. SPONSOR/MONITOR'S ACRONYM(S)	
				11. SPONSOR/MONITOR'S REPORT NUMBER(S)	
12. DISTRIBUTION/AVAILABILITY STATEMENT <b>Approved for public release; distribution unlimited</b>					
13. SUPPLEMENTARY NOTES <b>See also ADA239372. 22nd Annual Precise Time and Time Interval (PTTI) Applications and Planning Meeting, Vienna, VA, 4-6 Dec 1990</b>					
14. ABSTRACT <b>see report</b>					
15. SUBJECT TERMS					
16. SECURITY CLASSIFICATION OF:			17. LIMITATION OF ABSTRACT <b>Same as Report (SAR)</b>	18. NUMBER OF PAGES <b>5</b>	19a. NAME OF RESPONSIBLE PERSON
a. REPORT <b>unclassified</b>	b. ABSTRACT <b>unclassified</b>	c. THIS PAGE <b>unclassified</b>			

summation sign in equation (1), and instead use cosine and sine sums of the sampled data to represent the phasor:

$$X = X_c - jX_s \quad (2)$$

where

$$X_c = \sum_{k=1}^K x_k \cos k\omega\Delta t \quad , \quad X_s = \sum_{k=1}^K x_k \sin k\omega\Delta t \quad (3)$$

If the actual frequency of the power system differs from the nominal frequency used in the sampling process, the phasor calculated by equation (2) is in error. For all practical frequency deviations, the error in the phasor calculation is negligible. If the phasors of the three phases are given by  $X_a$ ,  $X_b$ , and  $X_c$ , the positive sequence quantity  $X_1$  (not to be confused with the fundamental frequency component computed by the DFT) is given by

$$X_1 = X_a + \alpha X_b + \alpha^2 X_c \quad (4)$$

where  $\alpha$  and  $\alpha^2$  are the usual phase shift operators of  $120^\circ$  and  $240^\circ$  respectively at the nominal frequency. An important use of the positive sequence voltage is the measurement of the power system frequency. If we write the positive sequence phasor in its polar form, the phase angle of the positive sequence phasor can be differentiated to obtain the incremental frequency of the input waveform over the nominal frequency. If  $\varphi$  is the phase angle of  $X_1$ , and  $\omega_0$  is the nominal frequency, then the actual frequency of the input signal is given by

$$\omega = \omega_0 + \frac{d\varphi}{dt} \quad (5)$$

Equation (5) is one of the most sensitive methods of measuring power system frequency.

## SYNCHRONIZATION OF THE SAMPLING PROCESS

The phasor given by equation (1) uses the sampling instant of the first sample as the reference. The necessary accuracy of synchronization may be specified in terms of the prevailing phase angle differences between buses of a power network. Typically, these angular differences may vary between a few degrees, to perhaps  $60^\circ$  under extreme loading conditions. Under these circumstances, a precision corresponding to  $0.1^\circ$  seems to be desirable to measure angular differences corresponding to lightly loaded systems. Allowing for other sources of error in the measurement system, it seems certain that a synchronizing accuracy of about 1  $\mu$ second would meet the needs of this measurement technique. A superior and satisfying solution to the synchronization problem is to use the 1 pulse-per-second (pps) transmission provided by the Global Positioning System (GPS) satellites.

## IMPLEMENTATION FOR FIELD TRIALS

A typical phasor measurement system is shown in Figure 1. The GPS receiver is designed to provide the standard 1 pps, a phase-locked sampling pulse at the desired sampling frequency, and a time-stamp corresponding to the 1 pps. The three signals from the GPS receiver are connected to a microprocessor, which acquires the power system current and voltage input signals through the signal conditioning units and the Analog-to-Digital converter. The microprocessor chosen for the task is a 16-bit processor with a sufficient instruction speed to accommodate between 1000 and 2000 instructions within the sampling period. The A/D converters are typically 12-bit converters, and with careful design of the computation algorithms, provide measurements with very good precision. The measured phasor, its associated time-stamp, and other message codes of interest are communicated to the next hierarchical level

over a communication channel. The local display port and the connected terminal is used to provide a graphic and alphanumeric display of the measured phasors, the reference phasor, the local frequency, and the rate of change of frequency. The system time error can be calculated by counting the rotations of the measured positive sequence voltage phasor with respect to the true time reference provided by the GPS receiver.

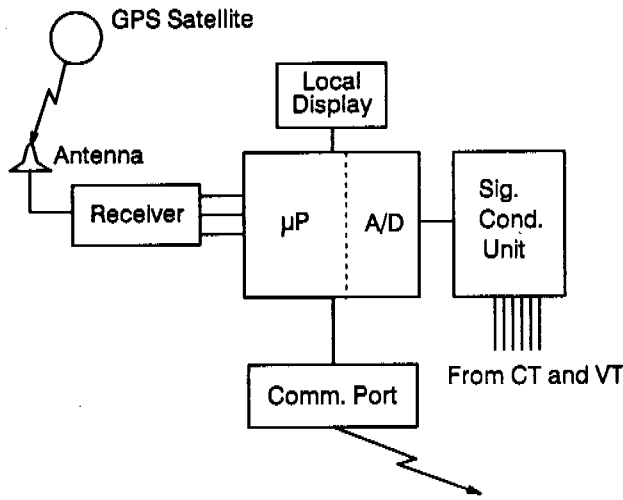

Figure 1.

Phasor Measurement System Block Diagram

the state of the power system with a non-linear state estimator. The measurement vector  $\mathbf{z}$  is a non-linear function of the state vector:

$$\mathbf{z} = \mathbf{h}(\mathbf{x}) + \epsilon \quad (6)$$

where  $\epsilon$  is the measurement noise with a covariance matrix  $\mathbf{W}$ . One could obtain the weighted-least-square (WLS) estimate of the state with an iterative algorithm:

$$\hat{\mathbf{x}}_{k+1} = \hat{\mathbf{x}}_k + (\mathbf{H}^T \mathbf{W}^{-1} \mathbf{H})^{-1} \mathbf{H}^T \mathbf{W}^{-1} [\mathbf{z} - \mathbf{h}(\hat{\mathbf{x}}_k)] \quad (7)$$

where  $\mathbf{H}(\mathbf{x})$  is the Jacobian matrix of the measurement functions:

$$\mathbf{H}(\mathbf{x}) = \frac{\partial}{\partial \mathbf{x}} \mathbf{h}(\mathbf{x}) \quad (8)$$

The iterations are continued until the measurement residual  $[\mathbf{z} - \mathbf{h}(\mathbf{x}_k)]$  becomes smaller than a pre-selected tolerance. A state estimation procedure such as that described above can never represent the dynamic phenomena occurring on the power system during transient power swings. The data scan rates in use at present are rather slow, and the non-linear iterative algorithm also contributes to the slow response time of the estimation process.

The synchronized phasor measurement technique provides the system state with direct measurements. Let the complete measurement set consist of positive sequence voltages at buses, and currents in transmission lines and transformers. These measurements are *linear* functions of the state vector:

$$\mathbf{z} = \begin{bmatrix} \mathbf{E} \\ \mathbf{I} \end{bmatrix} = \mathbf{B}\mathbf{x} \quad (9)$$

The measurement matrix  $\mathbf{B}$  now consists of two sub-matrices, the unity matrix, and a matrix relating the currents and the system state. This latter sub-matrix is similar to the familiar admittance matrix of the power system. In any case, the important point is that equation (9) is linear. Since  $\mathbf{B}$  is a complex matrix, the WLS solution is now given by

$$\hat{\mathbf{x}} = (\mathbf{B}^\dagger \mathbf{W}^{-1} \mathbf{B})^{-1} \mathbf{B}^\dagger \mathbf{W}^{-1} \mathbf{z} \quad (10)$$

## USES OF SYNCHRONIZED PHASORS

### State Estimation with Phasors

The collection of all positive sequence bus voltages of a power system is known as its state vector. A knowledge of the state vector is essential in many of the central control functions associated with power system operations. The present practice is to obtain measurements of various system quantities such as real and reactive power flow over transmission lines, real and reactive power injections, voltage magnitudes at system buses, line current magnitudes, etc., and estimate

Equation (10) can be much simplified by using the known structure of the admittance matrix elements.

An interesting distinction of the phasor measurement technique is that a complete system-wide data scan is not needed to complete the estimation process. The measured positive sequence voltages, with appropriate data validation done at the source, can be used directly. Thus, if the partial state vector is useful in some applications, it can be put to use immediately. For example, the phase angle between two regions of a network may be measured directly, in order to assess the inter-regional power transfer, without having to measure the connecting network, and then estimating the phase angle. In the next two sections, other examples of uses of partial state vector measurements will be discussed.

### *Improved Control with Phasors*

It is possible to improve post-disturbance power system performance using control schemes based on real-time phasor measurements. Present day controllers which act in such situations are restricted by the limited (local) nature of the measurements available to the controller. If synchronized phasor measurements from throughout the system are available, the quality of the control can be improved considerably. Such controllers for dynamic stability enhancement of AC/DC systems, and the application of real-time phasor measurements in generator exciter and speed governing system control has been reported in the technical literature. The key idea is to replace the non linear differential equation describing power system dynamics

$$\dot{\chi}(t) = f(\chi(t), u(t)) \quad (11)$$

by an equation that linearizes  $f$ , and then collects the remainder as a correction term

$$\dot{\bar{x}} = A \bar{x} + B u + [f(\chi_0 + \bar{x}, u) - A \bar{x} - B u] \quad (12)$$

Note that this equation (12) is not an approximation, it is in fact the same as equation (11). One may treat the term in the bracket

$$r(t) = f(\chi_0 + \bar{x}, u) - A \bar{x} - B u = \dot{\bar{x}} - A \bar{x} - B u \quad (13)$$

as a correction term, which is some unknown function of time. If sufficient observations of  $x(t)$  are available,  $r(t)$  can be predicted, and an optimal control law determined for the original system of equation (11). The resulting control law has several interesting properties, and it has been shown that the computational burden in the real-time control function can be accommodated in modern microcomputer based implementation.

In summary, we may say that real-time phasor measurements provide highly beneficial feedback to various controllers in use in power systems. Although a complete state vector feedback would be ideal, even partially observed states can help. With currently available communication channel speeds, the feedback can be obtained in a continuous data stream with state vector sampling periods of between 50 and 100 milliseconds. This makes the feedback most appropriate for controlling power system transients which lie in the frequency band of 0–5 Hz. Thus, most phenomena associated with electromechanical oscillations on power systems can be controlled with state vector feedback.

### *Protection with Phasors*

Protection is a form of control. Phasors play an important role in protection system design. In fact, modern phasor measurement techniques originated in the field of computer relaying.

It has now become clear that synchronized phasor measurements can be of great use in many of the protection applications. Although phasors may be used in many relaying tasks, their full impact is felt in the new field of adaptive relaying. *Adaptive Protection is a protection philosophy which permits and seeks to make adjustments in various protection functions automatically in order to make them more attuned to prevailing power system conditions.* The idea of adaptive relaying is an old one. Thus, existing protection systems try to adapt to changing system conditions in a limited manner. However, the advent of computer relaying has added a new dimension to this idea. For the first time, it is possible to imagine protection systems which can have dynamic settings, in order to provide the best protection possible in a changing environment. Of course, not all relay characteristics are amenable to adaptive adjustments. And, one must take care that in case of failures of the adaptive features, the relays revert to their pre-adaptive mode of operation. A number of studies of adaptive relaying have appeared in the technical literature in recent years. We will consider one example to give the flavor of this new and exciting development.

### *Detection of Instability*

This problem impacts many protection and control applications. As the power system undergoes oscillations of synchronizing power following a disturbance, it would be extremely useful to know in real-time whether the swing under development is going to lead to an instability. At present, this problem cannot be solved for a completely general system, but progress can be made in case of systems with two areas of concentrated load-generation complexes, connected together by somewhat weak interconnections. These systems behave like the classical two-machine system. The detection of instability for such a problem is equivalent to an evaluation of the balance between the accelerating and decelerating powers using the equal area criterion. If  $\delta(t)$  is the angle between the two equivalent machines, the set of observations  $\{\delta_k; k = 1 \dots n\}$  can be used to predict the balance between the accelerating and decelerating areas on the P- $\delta$  plane. It has been observed that observations made over one quarter of the period of the electromechanical oscillation are sufficient to provide a reliable estimate of the outcome of a power swing.

As mentioned before, no such results for the general case of multi-machine oscillations exist at this time. Several promising approaches to this problem — such as the method of Potential Energy Boundary Surface, and Extended Equal Area — are currently under investigation.

### SUMMARY AND CONCLUSIONS

Synchronized measurement of power system parameters is now achievable with the time transmissions of the GPS satellites. The hardware costs associated with such a measurement system are comparable to those of other relays and measurement systems in general use at present. The synchronized phasor measurement systems are likely to have a significant impact on all aspects of power system operations in the coming years, and will usher in an era of electric power networks operating with greater efficiency and security.

### FOR FURTHER READING

Transactions of IEEE on Power Apparatus and Systems contain many of the research results described above. The book, *“Computer Relaying for Power Systems”*, by A. G. Phadke and J. S. Thorp, gives a coherent account of some of these developments.