

NPS-SE-09-015



**NAVAL
POSTGRADUATE
SCHOOL**

MONTEREY, CALIFORNIA

Maritime Domain Awareness: C4I for the 1000 Ship Navy

by

Agnello M., Astudillo J., Brown J., Jauregui M., and Krikorian B.

NPS MSSE Cohort 311-082

4 December 2009

Approved for public release; distribution is unlimited

Prepared for: The Systems Engineering Department

NAVAL POSTGRADUATE SCHOOL
Monterey, California 93943-5000

Daniel T. Oliver
President

Leonard A. Ferrari
Executive Vice President and Provost

This report was prepared for the Chairman of the Systems Engineering Department in partial fulfillment of the requirements for the degree of Master of Science in Systems Engineering.

Reproduction of all or part of this report is authorized.

Mr. Mark Agnello, NSWC
Corona, CA

Mr. Julian Astudillo, NSWC
Corona, CA

Mr. Mike Jauregui, NSWC
Corona, CA

Mr. Jeff Brown, Boeing
Huntington Beach, CA

Mr. Brandon Krikorian,
Raytheon, El Segundo, CA

Reviewed by:

Reviewed by:

Mr. John M. Green
Lead Project Advisor

David A. Hart, Ph.D.
Project Advisor

Released by:

Clifford A. Whitcomb, Ph.D.
Chair
Department of Systems Engineering

Karl A. van Bibber, Ph.D.
Vice President and Dean of Research

REPORT DOCUMENTATION PAGE			<i>Form Approved OMB No. 0704-0188</i>
Public reporting burden for this collection of information is estimated to average 1 hour per response, including the time for reviewing instruction, searching existing data sources, gathering and maintaining the data needed, and completing and reviewing the collection of information. Send comments regarding this burden estimate or any other aspect of this collection of information, including suggestions for reducing this burden, to Washington headquarters Services, Directorate for Information Operations and Reports, 1215 Jefferson Davis Highway, Suite 1204, Arlington, VA 22202-4302, and to the Office of Management and Budget, Paperwork Reduction Project (0704-0188) Washington DC 20503.			
1. AGENCY USE ONLY (Leave blank)	2. REPORT DATE December 2009	3. REPORT TYPE AND DATES COVERED Technical Report	
4. TITLE AND SUBTITLE: Maritime Domain Awareness: C4I for the 1000 Ship Navy		5. FUNDING NUMBERS N/A	
6. AUTHOR(S) Agnello M., Astudillo J., Brown J., Jauregui M., Krikorian B.			
7. PERFORMING ORGANIZATION NAME(S) AND ADDRESS(ES) Naval Postgraduate School Monterey, CA 93943-5000		8. PERFORMING ORGANIZATION REPORT NUMBER	
9. SPONSORING /MONITORING AGENCY NAME(S) AND ADDRESS(ES) N/A		10. SPONSORING/MONITORING AGENCY REPORT NUMBER	
11. SUPPLEMENTARY NOTES The views expressed in this report are those of the author and do not reflect the official policy or position of the Department of Defense or the U.S. Government.			
12a. DISTRIBUTION / AVAILABILITY STATEMENT Approved for public release; distribution unlimited		12b. DISTRIBUTION CODE	
13. ABSTRACT (maximum 200 words) The study applies structured systems engineering methods, domain patterns, and tools to develop architectures, an information exchange standard, and a cost estimate of hosted mission applications for the Thousand Ship Navy (TSN) Command, Control, Computers, Communications, and Intelligence (C4I) system concept for the Global Maritime Partnership (GMP) enterprise.			
14. SUBJECT TERMS C4I, Command and Control, Intelligence, 1000 Ship Navy, Maritime Domain Awareness, Systems Engineering, Global Maritime Partnership		15. NUMBER OF PAGES 256	
		16. PRICE CODE	
17. SECURITY CLASSIFICATION OF REPORT Unclassified	18. SECURITY CLASSIFICATION OF THIS PAGE Unclassified	19. SECURITY CLASSIFICATION OF ABSTRACT Unclassified	20. LIMITATION OF ABSTRACT UU

THIS PAGE INTENTIONALLY LEFT BLANK

Abstract

The study applies structured systems engineering methods, domain patterns, and tools to develop architectures, an information exchange standard, and a cost estimate of hosted mission applications for the Thousand Ship Navy (TSN) Command, Control, Computers, Communications, and Intelligence (C4I) system concept for the Global Maritime Partnership (GMP) enterprise.

THIS PAGE INTENTIONALLY LEFT BLANK

TABLE OF CONTENTS

I.	INTRODUCTION.....	1
A.	CAPSTONE STUDY DISCUSSION.....	1
	1. Study Scope.....	1
	2. Study Description.....	1
	3. Problem Statement.....	2
II.	BACKGROUND	7
A.	CHAPTER TSN HISTORY AND VISION.....	7
	1. 1000 Ship Navy Antiquity to Present	7
	2. TSN Tenets per CNO ADM Mullen and ADM Morgan	11
	3. Global Fleet Station and TSN	14
	4. Piracy and Humanitarian Aid Concerns	16
	5. Unconventional Operations: the “Soft Navy”	17
B.	STAKEHOLDER ORGANIZATIONS	19
	1. Authorities Having Legal Jurisdiction.....	20
	2. Constabulary Forces.....	22
	3. Nations’ Navies.....	22
	4. Private Vessels.....	23
	5. Commercial Shipping and Fishing	23
	6. Humanitarian Aid Organizations.....	24
	7. International Organizations and Partnerships	24
C.	EXISTING ARCHITECHURES AND SYSTEMS	25
	1. U.S. Maritime Domain Awareness	25
	2. U.S. Navy.....	26
	<i>a.</i> <i>FORCENET</i>	26
	<i>b.</i> <i>CENTRIXS</i>	26
	<i>c.</i> <i>Global Information Grid</i>	27
	<i>d.</i> <i>Caspian Guard</i>	27

D.	DATA EXCHANGE SYSTEMS	28
1.	Automatic Identification System	28
2.	Long Range Identification and Tracking	28
3.	SafeSeaNet	29
4.	ShipLoc	30
5.	Global Justice Information Sharing Initiative	30
6.	Joint C3 Information Exchange – Multilateral Interoperability Programme	31
III.	METHODOLOGY	33
A.	REQUIREMENTS DEVELOPMENT AND FUNCTIONAL ANALYSIS	34
B.	FUNCTIONAL MODEL AND DECOMPOSITION	35
C.	PATTERN METHODOLOGY	37
D.	INTERPRETIVE STRUCTURAL MODELING ANALYSIS.....	39
E.	DESIGN STRUCTURE MATRIX ANALYSIS.....	42
F.	INFORMATION EXCHANGE STANDARD	43
G.	ARENA PERFORMANCE MODELING	44
H.	OPERATIONAL ANALYSIS OF ALTERNATIVES	48
I.	MISSION SUCCESS	55
1.	Mathematical Basis for Combining Measure of Effectiveness and Measure of Performance.....	55
2.	Excel Decision Tree Modeling.....	57
J.	DEPARTMENT OF DEFENSE ARCHITECTURE FRAMEWORK MODELS	58
1.	Operational Views.....	58
2.	System Views	59
3.	Technical Views.....	59
K.	COST ESTIMATION MODELING	59
IV.	RESULTS	63
A.	OPERATIONAL DOMAIN.....	63

1.	Declaration of Operational Functions.....	63
2.	Operational Analysis of Alternatives	66
	<i>a. Supporting Arena Modeling Results</i>	<i>66</i>
	<i>b. Team Model Analysis Results.....</i>	<i>70</i>
	<i>c. Group Model Analysis Results</i>	<i>70</i>
	<i>d. Committee Model Analysis Results</i>	<i>71</i>
	<i>e. TSN Rating Rubric Analysis</i>	<i>72</i>
	<i>f. Operational Force Mix and Mission Duration Consequence.....</i>	<i>73</i>
	<i>g. AoA Sensitivity Analysis</i>	<i>73</i>
3.	Concept of Operations.....	74
4.	Operational Functions, Nodes, and Needlines.....	76
	<i>a. Provide Intelligence Operational Function</i>	<i>77</i>
	<i>b. Provide Command and Control Operational Function.....</i>	<i>78</i>
	<i>c. Operate Unit Operational Function.....</i>	<i>79</i>
	<i>d. Operational Nodes.....</i>	<i>80</i>
	<i>e. TSN Needlines.....</i>	<i>82</i>
5.	Operational Scenarios	85
	<i>a. Evaluate Range of Options Operational Scenario.....</i>	<i>86</i>
	<i>b. Collect and Distribute Intelligence Operational Scenario</i>	<i>87</i>
	<i>c. Situation Awareness Operational Scenario</i>	<i>88</i>
	<i>d. Transnational Threat Operational Scenario</i>	<i>89</i>
	<i>e. Deliver Humanitarian Aid Operational Scenario</i>	<i>90</i>
	<i>f. Disaster Relief/Protect Environment Operational Scenario.....</i>	<i>91</i>
6.	Estimate of Mission Success.....	92
	<i>a. Transnational Threat Enforcement Mission Success</i>	<i>93</i>
	<i>b. Humanitarian Aid Mission Success.....</i>	<i>94</i>
	<i>c. Disaster Relief/Protect Environment Response Mission Success.....</i>	<i>96</i>

7.	Operational Architecture Assessment.....	98
8.	Operational Requirements.....	99
9.	Operational Test and Evaluation Plan.....	99
B.	SYSTEM DOMAIN.....	100
1.	System Functions and Services.....	100
a.	<i>Operational Activities and System Function Mapping.....</i>	<i>101</i>
b.	<i>Operational Information and Information Item Mapping..</i>	<i>102</i>
c.	<i>Manage Communication and Network.....</i>	<i>104</i>
d.	<i>Develop Situation Awareness.....</i>	<i>104</i>
e.	<i>Develop Object of Interest Tracks.....</i>	<i>105</i>
f.	<i>Obtain Intelligence Products.....</i>	<i>105</i>
g.	<i>Develop and Evaluate Plans.....</i>	<i>105</i>
h.	<i>Coordinate and Monitor Operations.....</i>	<i>106</i>
i.	<i>Generate After Action Evaluation.....</i>	<i>106</i>
2.	System Function to Components Assignment.....	107
a.	<i>Component Interfaces and Information Exchange.....</i>	<i>110</i>
b.	<i>Architecture Assessment.....</i>	<i>115</i>
3.	Information Exchange Standard.....	116
4.	Critical Technical Parameters.....	118
C.	MISSION APPLICATIONS SYSTEM AND SOFTWARE ENGINEERING COST ESTIMATE.....	119
1.	Mission Applications Systems Engineering Cost Estimate.....	119
2.	Mission Applications Software Cost Estimate.....	123
V.	CONCLUSION.....	131
A.	PROBLEM STATEMENT.....	131
B.	BACKGROUND.....	131
C.	METHODOLOGY.....	132
D.	STUDY RESULTS.....	133
E.	RECOMMENDATIONS.....	136
VI.	LIST OF REFERENCES.....	1

VII.	PIRACY ANALYSIS.....	VII-1
VIII.	APPENDIX OPERATIONAL DOMAIN SUPPORTING MATERIAL.....	VIII-1
IX.	APPENDIX OPERATIONAL TEST AND EVALUATION PLAN	IX-1
A.	SECTION 1. INTRODUCTION TO THE STUDY.....	IX-1
	1. Purpose.....	IX-1
	2. System Description.....	IX-1
B.	SECTION 2. MISSION NEED AND OPERATIONAL REQUIREMENT	IX-1
	1. Mission Need.....	IX-1
	2. Operational Requirements.....	IX-2
C.	SECTION 3. SCOPE OF THE EVALUATION	IX-2
	1. Critical Technical Parameters	IX-2
	2. Critical Operational Issues.....	IX-2
	3. Measures of Effectiveness/Suitability, Measures of Performance and Data Record	IX-3
	4. Test Scenarios.....	IX-7
	5. Instrumentation Requirements	IX-8
D.	SECTION 4: OPERATIONAL EFFECTIVENESS.....	IX-12
	1. Test Scenario Descriptions	IX-12
	2. E-Tests Descriptions	IX-14
E.	SECTION 5. OPERATIONAL SUITABILITY	IX-17
	1. Test S-2. Surviving the operational environment capability. ..	IX-17
	2. Test S-3. Degraded operations capability.	IX-17
F.	T&E ANNEX A: RESOURCE REQUIREMENTS	IX-17
G.	T&E ANNEX B: DATA SHEETS AND QUESTIONNAIRES.....	IX-19
X.	APPENDIX SYSTEM DOMAIN SUPPORTING MATERIAL	X-1
XI.	APPENDIX INFORMATION EXCHANGE STANDARD.....	XI-1
A.	SCOPE	XI-1
B.	VESSEL INFORMATION	XI-1

C.	OTHER INFORMATION INPUTS/OUTPUTS.....	XI-2
D.	INFORMATION REFRESH RATES	XI-2
E.	INFORMATION ELEMENT	XI-2
F.	CONFIGURATION ITEMS.....	XI-7
XII.	INITIAL DISTRIBUTION LIST	XII-9

LIST OF FIGURES

Figure 1.	Functional Problem Sequence Process Flow.	4
Figure 2.	United States Navy Ship Count, 1917 to 2008 (Navy Historical Center 2008).	10
Figure 3.	Naval Presence and Globalization (Looney, Schradly and Porch 2001).	14
Figure 4.	TSN Stakeholder Taxonomy.....	20
Figure 5.	Summary of Process, Methods and Tools Used in this Study.	33
Figure 6.	Functional Dendritic Model.....	35
Figure 7.	CORE® Schema Used for Modeling.....	37
Figure 8.	Top-Down Relationship Among Patterns (Bowler et al. 2009).....	38
Figure 9.	Digraph to Undirected Incidence Translation (Hitchins 1998).....	40
Figure 10.	©CADRAT Scoring Concept (Hitchins 1998).	41
Figure 11.	Effect of Cluster Algorithms (Hitchins 1998).	42
Figure 12.	DSM Concept of Representing Feedback (Yassine 2004).	43
Figure 13.	Triangle Distributions Used in Arena Processes.	45
Figure 14.	Team Model Triangle Distribution Development.....	46
Figure 15.	Group Model Triangle Distribution Development.	47
Figure 16.	Committee Model Triangle Distribution Development.	48
Figure 17.	Group Organizational Alternative Structure.....	49
Figure 18.	Team Organizational Alternative Structure.....	50
Figure 19.	Committee Organizational Alternative Structure.	51
Figure 20.	Political Feasibility S-Curve.....	54
Figure 21.	Notional Series Network (Blanchard and Fabrycky 2006).....	56
Figure 22.	Notional Parallel Network (Blanchard and Fabrycky 2006).	56
Figure 23.	Mission Success Decision Tree.	57
Figure 24.	Declaration of Intelligence Operational Functions Using Dendritic Method.....	64
Figure 25.	Declaration of C2 Operational Functions Using Dendritic Method.	65
Figure 26.	Arena Response Operational Function Model.....	67

Figure 27	Situation Awareness Operational Function Model.	67
Figure 28.	Intelligence Operational Function Model.	67
Figure 29.	TSN Operational View.	74
Figure 30.	TSN Operational Function Hierarchy.	77
Figure 31.	Provide Intelligence Operational Function FFBD.	77
Figure 32.	TSN Provide Command and Control Operational Function FFBD.	78
Figure 33.	TSN Operate Unit Operational Function FFBD.	79
Figure 34.	TSN Operational Nodes Hierarchy.	80
Figure 35.	TSN Needlines Operational Node Diagram.	83
Figure 36.	TSN Evaluate Range of Options Operational Scenario FFBD.	86
Figure 37.	TSN Collect and Distribute Intelligence Operational Scenario FFBD.	87
Figure 38.	TSN Situation Awareness Operational Scenario FFBD.	89
Figure 39.	TSN Transnational Threat Operational Scenario FFBD.	90
Figure 40.	TSN Deliver Humanitarian Aid Operational Scenario FFBD.	91
Figure 41.	TSN Disaster Relief/Protect Environment Operational Scenario FFBD.	92
Figure 42.	TSN Transnational Threat Enforcement Mission Tree Analysis.	94
Figure 43.	TSN Humanitarian Aid Mission Tree Analysis.	96
Figure 44.	TSN Disaster Relief/Protect Environment Mission Tree Analysis.	97
Figure 45.	Operational Architecture Method Analysis Summary.	98
Figure 46.	TSN C4I System Function Hierarchy.	100
Figure 47.	TSN C4I Component Physical Diagram.	107
Figure 48.	System Architecture Method Analysis Summary.	115
Figure 49.	TSN C4I COSYSMO Size Drivers.	119
Figure 50.	TSN C4I COSYSMO Team Cost Drivers.	120
Figure 51.	TSN C4I COSYSMO Application Cost Drivers.	121
Figure 52.	TSN C4I Systems Engineering Costs per Phase.	122
Figure 53.	TSN C4I COCOMO II functional point summary.	123
Figure 54.	TSN C4I COCOMO II Scale Factors.	124
Figure 55.	TSN C4I Software Development Cost Estimate.	127
Figure 56.	Flow Down of Processes, Methods and Tools Used to Reach Conclusion. ...	133

Figure 57.	Committee Organizational Model.....	134
Figure 58.	Design Structured Matrix (Lattix) Complete Analysis Worksheet for Operational Domain.....	VIII-29
Figure 59.	Interpretative Structured Matrix (CADRAT) Complete Analysis for Operational Domain.....	VIII-30
Figure 60	OT&E Plan Scenario Diagram.....	IX-12
Figure 61.	TSN C4I Top Level A-1 IDEF0 Diagram.	X-1
Figure 62.	Manage Communication and Network System Function IDEF0 Diagram. .	X-2
Figure 63.	Develop Situation Awareness System Function IDEF0 Diagram.	X-3
Figure 64.	Develop Object of Interest Tracks System Function IDEF0 Diagram.	X-4
Figure 65.	Obtain Intelligence Products System Function IDEF0 Diagram.....	X-5
Figure 66.	Develop and Evaluate Plans System Function IDEF0 Diagram.....	X-6
Figure 67.	Coordinate and Monitor Operations System Function IDEF0 Diagram.	X-7
Figure 68.	Generate After Action Evaluation System Function IDEF0 Diagram.....	X-8
Figure 69.	Design Structured Matrix (Lattix) Completed Analysis Worksheet for System Domain.....	X-24
Figure 70.	Interpretative Structured Matrix (CADRAT) Complete Analysis Worksheet for System Domain.....	X-25

THIS PAGE INTENTIONALLY LEFT BLANK

LIST OF TABLES

Table 1.	TSN Stakeholder Functional Matrix.....	52
Table 2.	AoA Rating Rubric.	53
Table 3.	AoA Weight Distribution.....	53
Table 4.	Political Feasibility Evaluation Factor Scoring Table.	54
Table 5.	Event Occurrence Times and Parameter Lambda.....	68
Table 6.	Arena Operational Function Baseline Triangle Distributions.	68
Table 7.	Arena Modeling Results Extracted for AoA.....	69
Table 8.	Organization Model AoA Rating Rubric.....	72
Table 9.	Operational Node and Operational Function Mapping.....	82
Table 10.	TSN Operational Nodes and Needlines.	85
Table 11.	TSN Mission Success for Transnational Threat Enforcement.....	93
Table 12.	TSN Mission Success for Humanitarian Aid.....	95
Table 13.	TSN Mission Success for Disaster Relief/Protect Environment.....	97
Table 14.	System View 5, Operational Activities to System Function Mapping.	101
Table 15.	Operational Information to Information Item Mapping.....	103
Table 16.	Component and System Function Assignment.	110
Table 17.	Information Items Carried on Component Interfaces.	115
Table 18.	TSN C4I Network Information Elements.	117
Table 19.	TSN C4I Network CSCI List.....	117
Table 20.	TSN C4I Network CSCI List.....	118
Table 21.	TSN C4I Critical Technical Parameters.	118
Table 22.	TSN C4I Systems Engineering Developmental Costs.....	122
Table 23.	Early Design Values for Post-Architecture Cost Factors (Boehm et al. 2000).	124
Table 24.	TSN C4I Early Design Cost Factors (Boehm et al. 2000).....	125
Table 25.	Gulf of Aden Piracy Analysis January 2009 to March 2009 (International Chamber of Commerce, Commercial Crime Services, IMB Live Piracy Map).....	VII-1

Table 26.	Team Organization Process Times for Transnational Threat Enforcement, Humanitarian Aid, and Disaster Relief/Protect Environment.....	VIII-1
Table 27.	Committee Organization Process Times for Transnational Threat Enforcement.....	VIII-2
Table 28.	Group Organization Process Times for Transnational Threat Enforcement.....	VIII-3
Table 29.	Committee Organization Process Times for Humanitarian Aid and Disaster Relief/Protect Environment Response.....	VIII-4
Table 30.	Group Organization Process Times for Humanitarian Aid and Disaster Relief/Protect Environment Response.....	VIII-5
Table 31.	DODAF Operational View 3 Information Exchange.....	VIII-22
Table 32.	DODAF Operational View 7 Data Model.....	VIII-28
Table 33.	Test Objective Matrix.....	IX-7
Table 34.	Limitation to Scope of Test.....	IX-12
Table 35.	Resource Requirements.....	IX-18
Table 36.	System Domain Data Item Exchange.....	X-23
Table 37.	Data Refresh Rates for the TSN Network.....	XI-2

Executive Summary

Over millennia, the presence of naval forces with global reach correlates to peace and international prosperity. Encompassed by the Global Maritime Partnership (GMP) enterprise, the Thousand Ship Navy (TSN) is a concept envisioned by CNO Admiral Mullen, USN in 2005 to provide overwhelming maritime power by forming an alliance of multinational security forces and navies. With no single national power currently positioned, economically or politically, to unilaterally provision a TSN, its capability includes voluntary participation of international signatories, nations' navies, commercial, humanitarian and constabulary stakeholders. The TSN Command, Control, Communications, Computer, and Intelligence (C4I) capability established by this study addresses unprecedented requirements. In order to coordinate existing, albeit disparate systems, a top-level C4I system/software architecture is identified to support the TSN operational architecture and missions. Through the application of structured systems engineering methods, domain patterns, and analysis tools, the study developed requirements, defined functions, and synthesized architecture alternatives.

A distinction is made in the study between GMP and TSN where GMP represents the international enterprise construct and TSN represents the force level of this construct needed to achieve the objectives of GMP. The effect of improved technology has limited battlespace volume where fewer ships are required to dominate any ocean. Subsequently, the capability of a TSN in the modern era can be achieved with a fewer number of ships. Regardless of TSN size, TSN is an alliance of international partners who volunteer naval and constabulary assets that provide global maritime security, delivery humanitarian aid, and respond to disasters and environment events. A paradigm shift from the Global Fleet Station (GFS), the framework of TSN is based on an international vice a U.S. framework. The TSN C4I system is multi-tiered to achieve trust, confidentiality, and performance among participating stakeholders. These stakeholders operate, thus TSN operates, across legally defined jurisdictions of high seas, economic zones, and territorial waters.

Legacy systems which address maritime security fall into two categories. The first category is an adaptation of military systems, such as the U.S. Combined Enterprise

Regional Information Exchange System (CENTRIXS) and NATO's Multilateral Interoperability Program (MIP) Land Command and Control (C2) system. The second category includes commercial ventures and international organization systems, such as Collectè Localization Satellite's ShipLoc, Automatic Identification Systems (AIS) and Long Range Identification and Tracking (LRIT) systems. Due to military concerns, the first category is not viable for TSN. However, the second category is compatible with TSN as these systems are able to develop situation awareness to enable C2. Presently the International Chamber of Commerce's (ICC) International Maritime Bureau's (IMB) Piracy Reporting Center (PRC) is the only multinational effort to alert law enforcement, ship masters, and owners of imminent transnational threats. Its capability does not include humanitarian aid, disaster relief or environment governance scope.

The TSN C4I system intends to provide C2 capability for all TSN missions by applying a committee organizational model to its stakeholders. Supported by an Analysis of Alternatives (AoA), the committee approach is favored over the traditional team or candidate group approaches impart due to international political feasibility. The AoA is a weighted normalized matrix that transforms team assessments and data from nine Arena models. Random occurrences stimulate the models according to each mission type: 60 hours for a transnational threat, 98 hours for a humanitarian aid event, and 101 hours for disaster relief/protect environment event. Results from these models, resource usage and mission duration, are used by the AoA with other evaluation factors.

Employing the committee organizational model, three C4I system tiers are used to involve stakeholders utilizing backbone, edge, and broadcast capabilities. Backbone capability includes nations' navies, constabulary, and intelligence units that possess the highest access to TSN information and operations. Edge capability includes commercial shipping industry and humanitarian organizations that possess moderate access to TSN information and limited operations. Broadcast capability includes all other stakeholders, e.g., private stakeholders, with lowest level of access to basic TSN situation awareness information.

TSN C4I is organized into three critical operational functions: provide intelligence, perform command and control, and operate unit. Traditional operational

capability patterns are used for the first two functions. The operational capability pattern for provide intelligence is task, process, post, and use. The operational capability pattern for perform command and control is sense, assess, generate, select, plan, and direct. From functional analysis sub-functions are derived and allocated to the following operational nodes: C2, intelligence, and unit. The latter node is further instantiated to navy, constabulary, humanitarian, commercial, and private. Between these nodes, needlines and operational information describe the dependencies between these nodes.

From the arrangement of operational nodes an operational architecture is developed and assessed with mission success and structural analysis. The following operational scenarios have a mission success likelihood of: 75 percent for disaster relief/protect environment, 64 percent for humanitarian aid, and 63 percent for transnational threat. The difference of functional arrangements associated with each operational scenario drive separate results. Structural assessment of the operational architecture results in the following acceptable scores: a cluster factor of 1.8, where 1.0 is ideal, and a system stability of 72 percent, where 100 percent is ideal. Additionally, an operational test and evaluation plan is provided for the TSN C4I system as a validation approach, when the TSN C4I system undergoes operational testing.

A software system architecture is derived from the operational architecture that is portable across heterogeneous environments. Derived system functions are mapped to operational functions using a Department of Defense Architecture Framework version 1.5 (DoDAF) System View Five (SV-5). System sub-functions are derived and allocated to the following system architecture components: Asset Management Computer Software Configuration Item (CSCI), Situation Awareness CSCI, Fusion CSCI, Intelligence CSCI, Mission Planning CSCI, Mission Operations CSCI, Mission Analysis CSCI, Information Release CSCI, and Communications, and Network Management Service. Structural assessment of the system architecture also results in acceptable scores: a cluster factor of 1.5, where 1.0 is ideal, and a system stability of 80 percent, where 100 percent is ideal.

Determined from the operational architecture, needlines and operational information, system data items, and their interfaces are developed. On this foundation an

information exchange standard is provided for the TSN C4I system. This exchange standard represents essential information elements which pass among TSN stakeholders.

As the final achievement of this study, the TSN C4I architectures are evaluated to determine an estimate cost of development. An estimated total for developing the CSCIs hosted by the TSN C4I system is the combination of both systems and software engineering costs. With a confidence level of 50 percent for the systems engineering estimate, and 80 percent for the software engineering estimate, the total cost is \$9.68 million assuming a \$60.00 labor rate.

I. INTRODUCTION

Chapter I briefly introduces the 1000 Ship Navy (TSN) Command, Control, Communications, Computers, and Intelligence (C4I) concept. A description of the TSN problem forms the basis of the subsequent thesis description, analysis and conclusion. Chapters II through V contain research results, study methodology, and present results of the study. Results include: an operational architecture, software system architecture, an information exchange standard, an estimate of mission application development cost and corroborating analysis all of which address the problem statement of Chapter I. Appendixes VIII to X11 contain supporting details referenced from the body of the thesis.

A. CAPSTONE STUDY DISCUSSION

1. Study Scope

Global Maritime Partnership (GMP), an enterprise, relies upon TSN which is composed nations' navies, constabulary forces, commercial shipping, and other international partners that have mutual concerns but limited information exchange capabilities. The ability of these partners to conduct coordinated maritime security and humanitarian assistance operations is hampered when participants of the enterprise are not supported by an integrated command and control process. This study seeks to define a systems of system architecture and information exchange standard for a C4I capability to enable collaboration within TSN.

2. Study Description

In 2005 former Chief of Naval Operations (CNO) Admiral Mullen, USN advocated the TSN concept, which in combination with the maritime mission of North American Aerospace Defense Command (NORAD) fashioned the GMP enterprise. As promoted,

“The 1,000-ship Navy is not a thousand gray hulls flying the American flag, but rather a voluntarily global maritime network that ties together the

collective capabilities of free nations to establish and maintain a dramatically increased level of international security in the maritime domain” (Martoglio and Morgan 2005).

In 2006 Commandant of the Coast Guard, Admiral Collins, USCG, and CNO Admiral Clark, USN, put forward the Maritime NORAD concept. This concept renewed Coast Guard-Navy team commitment and highlighted the need for international maritime cooperation. At the root of this vision, system capabilities supplement USN, USCG, and international partner naval platforms to enable global security. These concepts came together to support the GMP enterprise which the U.S. State Department adopted by implementing the Pacific Partnership and Partnership of the Americas. In 2008, the U.S. National Security Council sanctioned GMP as an interagency strategy (Swartz and Duggan 2008).

Concerns shared within the international community include maritime security acts against humanity, e.g., persecution, exploitation, and forcible recruitment. Global maritime security is a fundamental naval mission, i.e., protecting the Sea Lines of Communication (SLOC). The world’s commercial fleet carries ninety percent of global exports and comprises approximately 46,000 commercial ships (Morgan 2006). Dependent on secure SLOC, maritime commerce abhors explicit or implicit risks from criminal elements and political extremists. Protection of humanitarian aid ships and the use of global reach capabilities in distraught areas are examples of unconventional operations supporting the U.S. State Department 2007-2012 strategy, which aims to stabilize legitimate nations and thwart terrorism (U.S. Department of State 2007). In this strategy the U.S. Navy projects power to save lives and support humanitarian objectives. Recently, the international community has undertaken forceful humanitarian interventions that merge security and humanitarian efforts. For example, the failed Somali state requires armed protection of humanitarian aid providers.

3. Problem Statement

The global maritime community faces a serious dilemma concerning the inability to provide an international coordinated response, either to transnational criminal threats, events compelling humanitarian assistance, or response to environment events. The

complex nature of the dilemma is confounded by: the lack of a common information exchange standard, lack of an international C4I system, legal prosecution procedures, languages, cultural issues, national interests, and political willingness to participate.

Defining what constitutes a transnational criminal threat impacts the actions of the international community specifically their legal, naval, constabulary, political, commercial, and charitable systems. The White House provides guidance that transnational criminal threats are

“Modern-day pirates and other criminals [who] are well organized and equipped, often possessing advanced communications, weapons, and high speed craft to conduct smuggling of people, drugs, weapons, and other contraband [e.g. counterfeiting, illegal fishing, etc.], as well as piracy” (U.S. Department of Defense Chief Information Officer 2009).

In addition, the United Nations Conventions on Law of the Sea (UNCLOS), Article 101, provides an international legal framework that constrains hot pursuit, interdiction, and jurisdictional incursion into a nation’s territorial waters (Scudder 2005). Events defined as necessitating humanitarian assistance include: “conflict, disaster, and displacement from physical harm, persecution, exploitation, abuse, malnutrition and disease, family separation, gender-based violence, forcible recruitment, and other threats [to humanity]” (U.S. Department of State 2007).

Today, the international maritime community employs independent systems that respond to transnational criminal threats, events requiring humanitarian assistance and environment governance. Although a broad study of these systems and their interactions is warranted, the objective of this study focuses on the underlying need of a common maritime C4I system of systems encompassing naval systems, constabulary systems, commercial shipping, and other international partners of the maritime community. GMP necessitates an agile approach where any single participant may join or leave the Command and Control (C2) framework without degrading performance.

The GMP enterprise is reliant on the “cooperation among maritime nations, who share a stake in international commerce, safety, security, and freedom of the seas” (Woodson 2007). In Figure 1, the C2 pattern is employed at the enterprise level, as well as the platform level. To participate in the enterprise the platform must exercise its C2

and contribute towards one or more enterprise C2 activities. The C4I system of systems is composed of the watch chain activities bounded by the red dotted box to include only a subset of these activities that occur after an external threat or event. These activities are shared between the naval, constabulary, and commercial maritime industrial systems. The last two activities outside the dotted red box are incorporated into the TSN kill chain which is not explicitly addressed in this thesis.

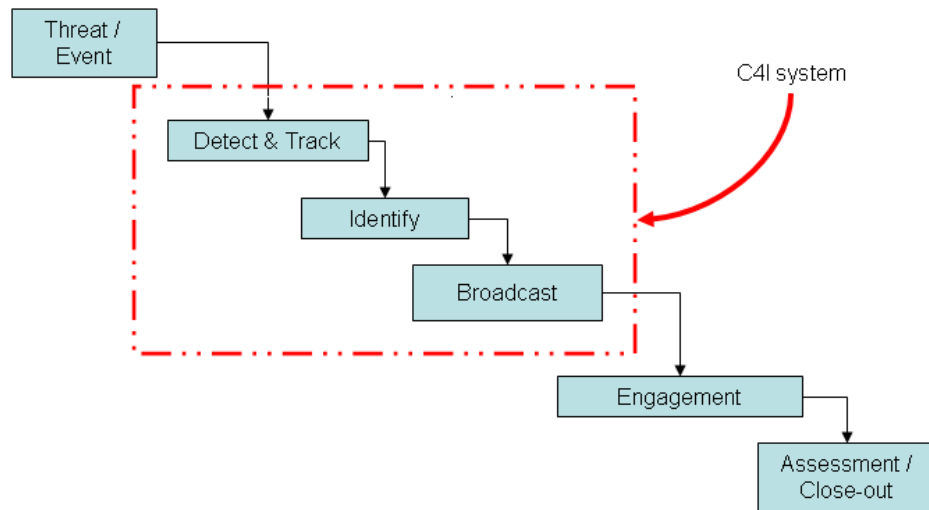

Figure 1. Functional Problem Sequence Process Flow.

Author generated traditional command and control operational capability pattern.

The GMP enterprise consists of sovereign nations, business corporations, and other international partners whom have confidentiality and privacy concerns yet common maritime interests. As an example, maritime business operations which are vulnerable to criminal acts prefer to conduct business with a degree of privacy to preserve competitive advantage. Additionally, law enforcement agencies protect their intelligence methods to preserve collection techniques and information sources. In this setting, the C4I system of systems must balance confidentiality, privacy, and information exchange to support nation, business, and partner participation in the voluntary TSN.

In summary a distinction is made in the study between GMP and TSN where GMP represents the international enterprise level and TSN represents the force level needed to achieve the objectives of the GMP. Regardless of TSN force size, TSN is an alliance of international partners who volunteer naval and constabulary assets to provide

maritime security, delivery humanitarian aid, and respond to disasters and environment events. A segment of TSN is C4I, the ability to provide coordinated response of the TSN missions. At the USN and USCG flag level a vision has formed for maritime forces to combine resources to protect the SLOC from threats affecting international communities consistent with restrictions of law. In Chapter IV inclusion of the USMC and alignment with national policy via the U.S. Department of State is discussed.

The problem addressed by this study is the need of a C4I system for international coordinated transnational threat enforcement, humanitarian aid, and disaster relief/protect environment response. Development of this capability is confounded by the nature of internationalism: diverse information standards, disparate communication systems, different navigation systems, dissimilar operating procedures, and lack of overarching C2 organizational construct. In this international setting, C4I must balance trust, confidentiality, and performance with information exchange to support nation, business, and partner participation in the voluntary TSN.

The report is composed of 5 chapters. Chapter I describes the introduction of TSN. Chapter II describes background regarding the TSN concept and disparate systems. Chapter III describes methodologies employed to study TSN and develop both operational and system architectures. Chapter IV describes the results of applying the methodologies. Chapter V provides a thesis conclusion. In addition, appendixes are provided which contain the results of analysis, of interest, e.g., TSN C4I operational test and evaluation plan and TSN C4I information exchange standard.

THIS PAGE INTENTIONALLY LEFT BLANK

II. BACKGROUND

Chapter II describes research findings relevant to TSN. In addressing the question, “Why the phrase ‘one thousand ship navy’?”, Chapter II summarizes the historical use of the phrase by establishing a correlation between naval presence and economy prosperity. Tenets of TSN are discussed in the context of policy and directives established by: U.S. Department of State, U.S. DoD, USN, USMC, and USCG. TSN stakeholders are described with respect to their interests and viewpoints influencing TSN mission complexity. In support of U.S. national outreach policy, aspects of the “Soft Navy” and related Global Fleet Station (GFS) concepts are compared to TSN objectives. A survey of legacy systems compares their maritime security capability to TSN goals with an assessment of their limitations.

A. CHAPTER TSN HISTORY AND VISION

1. 1000 Ship Navy Antiquity to Present

From Persian sea dominance in antiquity through recent times, the 1000 ship navy is a standard of sea power. The Persians employed a 1000 ship fleet in combination with its army to subdue the Greeks to the west. In the Bronze Age, threatened by the Persian menace, the independent Greek city-states volunteered vessels and men to combat the Persian force. As recorded by Homer in the Iliad, the Greeks raised a fleet of 1000 ships to attack the city of Troy for the rescue of Helen; however, most historians believe 600 vessels were provisioned. Over three millennia the 1000 ship naval force has been the historical measure of dominant naval presence.

With the ending of the Dark Ages, 750 B.C., on the island of Delos the Greek states formulated a naval force capable of combating the Persian might. The Delian League remained in effect until the second Persian invasion in 480 B.C. when a fleet of 310 vessels half manned by Athenians encountered the Persians at the island of Salamis. With demonstrated Athenian prowess, the league was all but renamed the Athenian League (Connolly 2006). The league continued its growth and dominance throughout the

Mediterranean until subsumed by the Roman Navy. The Athenian League's existence created a period of commercial success for the entire Eastern Mediterranean with peacekeeping and protection of commerce (Cline 1975).

The Greek civilization remained a dominant sea power which influenced the rise of the Roman Navy although Rome subjugated its navy under the control of the Roman Armies. The early design of the Roman vessel was based on the Greek trireme until the First Punic War when a captured Carthaginian vessel, a quinquireme, became the new blueprint for Rome's navy which reached 200 vessels during the Second Punic War. Towards the end of this war and in the Eastern Roman area of influence, the Roman Navy combined with Pergamon and Rhodes to defeat Macedon. The functioning Roman-Greek alliance then battled and defeated the Hellenistic Seleucid Empire which assured Roman dominion over the Mediterranean. Reducing its navy over time, Rome exercised control of the Mediterranean by means of the Roman-Greek Alliance relying on its subject's navies. Essentially, Rome extended its vicarious authority on Greek city-states during the successful execution of various sea campaigns (Connolly 2006). Of interest, the period when Rome dominated the Mediterranean was associated with peace and prosperity, Pax Romana.

Similar to Persia's supremacy in the Bronze Age, the United Kingdom (U.K.) established the Pax Britannica period (1815 - 1914) with a fleet size of about 950 ships. During this period the Royal Navy was effectively unchallenged and British influence flourished (Royal Navy 2009). The U.K. wielded its naval might as a hegemonic industrial power responsible for two-thirds of Europe's industrial growth and output. During this period one-third of merchant marine flew under the British flag sustaining the U.K. portion of two-fifths of the world's commerce. Although the Royal Navy size steadily decreased, by comparison to other navies, it remained as powerful as the next combined three to four largest navies, Russian, French, and U.S. (Kennedy 1987).

Modeled on the Athenian League Alliance (Cline 1975) or Roman-Greek Alliance (Sakhuja 2007), during the Cold War, the US calculated the concept of an association of seagoing trading states. Known as the Ocean Alliance, it would join nations together to

provide mutual security capability. The Open Alliance refers to the Atlantic and Pacific oceans linking the North American geopolitical community which was conceived as the core group. With common political and social process, its membership included: the United States, Canada, the United Kingdom, West Germany [FRG], France, Italy, the Netherlands, Israel, Japan, China/Taiwan [ROC], Australia, and New Zealand. Even with an implemented Open Alliance, other U.S. alliance commitments would have continued such as the North Atlantic Treaty Organization (NATO) and their combination would provide an overlapping security capability (Cline 1975).

In some manner the Open Alliance may have formed the conceptual foundation of the Proliferation Security Initiative (PSI) launched in 2003. The PSI alliance is comprised of 101 countries with notably absent countries of China, Egypt, Saudi Arabia, India, Pakistan, and Malaysia (U.S. Department of State 2009). The prime objective is preventing the proliferation of weapons of mass destruction, which critics view as targeting North Korea and Iran. At present U.S. bilateral agreements are in place between flag states to allow for the legal boarding of ships under their flag. There exists the expectation that the cooperative alliance can be improved with a wider mandate of interdiction through multilateral agreements (British American Security Information Council). The ability to arrive at such agreements is challenging diplomacy when the PSI is viewed as a hallmark of NATO and ANZUS [Australia, New Zealand, U.S.] Mutual Defense Pact with the U.S. (Kapila 2004).

In the context of alliances of past and present, TSN was discussed at various levels in seminars and conferences the world over. In fact, senior officers of the U.S. Department of the Navy took the opportunity to exemplify the CNO's concept during the AFCEA Western Conference Exposition in January 2007. Vice Admiral John G. Morgan, Jr., Deputy Chief of Naval Operations for Information, Plans and Strategy and Rear Admiral Michael C. Bachman, Commander, Space and Naval Warfare Systems Command gave further details on the TSN concept that aims to build a network of navies who would work together to create a force capable of "standing watch over all the seas" (Sakhuja 2007). Critics conjecture the motivation of the U.S. proposed TSN is driven by current and foreseeable low numbers of U.S. Navy ships.

The U.S. Navy ship count varied throughout the 20th and 21st centuries, as shown in Figure 2, adjusting to wars and conflicts (Naval Historical Center 2008). While preparations for World War One (WWI) saw a dramatic increase of ship count, for the U.S. the war lasted two years and was followed by a reduction of ships. With the escalation of tensions and conflict in Europe, the USN built a force which peaked at 6768 ships during World War Two (WWII). This force was rapidly reduced and then rebuilt for the Korean conflict. Following this conflict the cold war provided the justification to sustain the USN at a high count until following the end of the Vietnam conflict when the DoD budget was slashed in a popular reaction to the war's end.

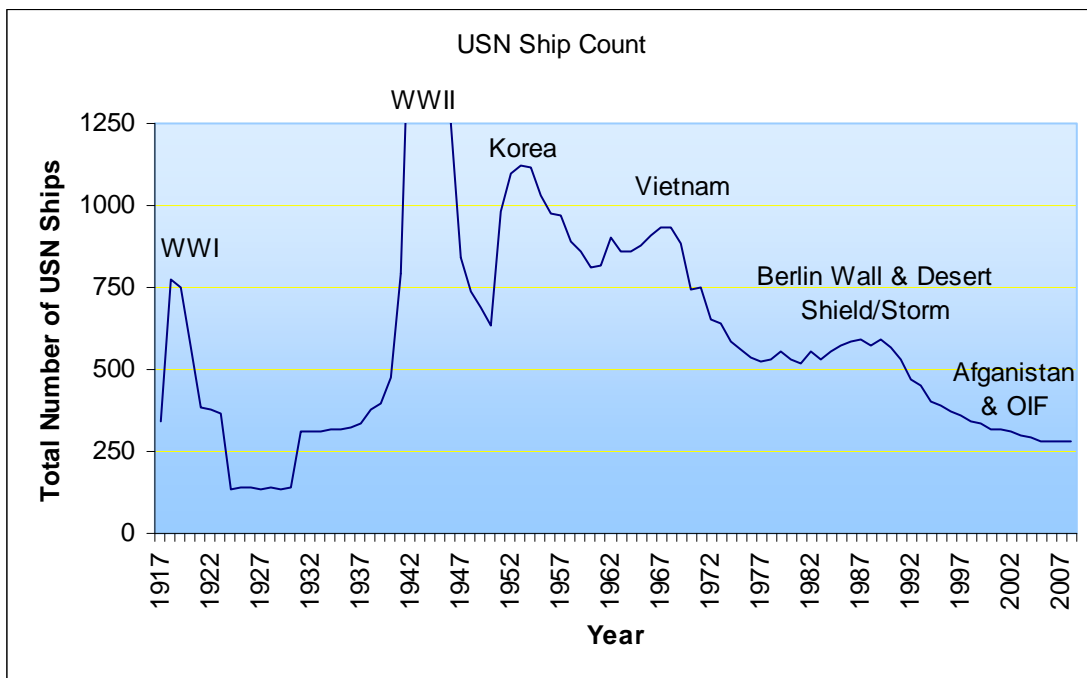

Figure 2. United States Navy Ship Count, 1917 to 2008 (Navy Historical Center 2008).

The USN ship count varies with the occurrence of wars and conflicts peaking during WWII at 6768 ships. The reduced ship count is offset by the increased combat capability of modern USN ships.

The slight build preceding the fall of the Berlin Wall is attributed to the Ronald Reagan administration's ambition to build towards a 1000 ship USN. Likely, budget

pressures and high profile acquisition programs compelled an easing of the ambition to a 600 ship objective. Following the fall of the Berlin Wall, the USN ship count was halved to 283 ships in 2008. Budget pressures and advancements in naval technology are likely to maintain the USN ship count at current levels.

Deduction indicates that a sovereign state or an alliance with approximately 1000 ships or more is a dominant maritime force. In the case of Pax Britannica, this naval force contributed to the first era of globalization which was characterized by a rapid growth in international trade and investment (Bordo and Meissner 2007). Modern globalization began during the Pax Americana period following the end of WWII with a migration of interconnected and competing global businesses throughout the world (Rowan 2006). As shown in Figure 2, during the Pax Americana period the U.S. naval ship count was approximately half of the historic number of ships due to improvements in naval technology.

In general, naval technology has improved combat power by means of weapon range, speed, and endurance. Between the 13th and 17th centuries, ships had a weapon range of 100 yards, a speed of 5 knots, and an unreplenished ship range of 400 nautical miles. Whereas, modern warships possess a weapon range of 1000 nautical miles, speeds near 40 knots, and unlimited ship range. The effect of improved technology has limited battlespace volume where fewer ships are required to dominate any ocean (Douglas 2009). Subsequently, the capability of a TSN in the modern era can be achieved with a fewer number of ships. One of the effects of modern globalization is the recognized value of multilateral political and commercial partnerships. Increased awareness of complex global dependencies has cultivated the notion of the TSN concept.

2. TSN Tenets per CNO ADM Mullen and ADM Morgan

The nature of the international security environment substantially changed on 11 September 2001. This event set in motion a dialogue resulting in the International Outreach and Coordination Strategy for the National Strategy for Maritime Security, signed by the U.S. Secretary of State in November 2005 (U.S. Department of State 2005). At this point in time, former CNO Admiral Mullen, USN advocated GMP to encapsulate

the enhanced outreach concept discussed by the U.S. Department of State strategy. Specifically, the expression “one thousand ship navy” achieved prominence based on the need to conduct major naval operations having more complex contingencies and a broader range of maritime missions. The accord, A Cooperative Strategy for 21st Century Seapower, signed by the Commandant of the Marine Corps, Chief of Naval Operations, and Commandant of the Coast Guard in October 2007 provided a community of forces for balancing warfare and peacetime activities to foster a “peaceful global system comprised of interdependent networks of trade, finance, information, law, people and governance” (U.S. Department of Navy 2007). The GFS concept for U.S. global maritime operations developed from this combined vision (Adkins 2008).

Principles of TSN are found in the International Outreach and Coordination Strategy for the U.S. National Strategy for Maritime Security, which is an extension of an earlier form of a U.S. Department of State policy. Notably, the strategy includes eight supporting plans to promote global economic stability and prevent hostile or illegal acts within the Maritime domain. These plans include trade routes, communication links and natural resources vital to the global economy. Possibly in awareness of the magnitude of effort needed to achieve global maritime security, the strategy emphasizes that a collaborative effort is required of agencies, nations, and private sector. Where the first of two strategic goals addresses coordinated policy, the second strategic goal addresses outreach, as follows (U.S. Department of State 2005):

- **Strategic Goal:** Enhanced outreach to foreign governments, international and regional organizations, private sector partners, and the public abroad to solicit support for improved global maritime security.
- **Strategic Objective #1:** Build partnerships with other countries and the maritime community to identify and reach out to regional and international organizations in order to advance global maritime security.
- **Strategic Objective #2:** Coordinate U.S. and international technical assistance to promote effective maritime security in developing nations and critical regions.

- **Strategic Objective #3:** Coordinate a unified message on maritime security for public diplomacy.
- **Strategic Objective #4:** Provide U.S. missions abroad with guidance to enable them to build support for U.S. maritime security initiatives with host governments, key private-sector partners, and the general public abroad.

On the basis of these goals, the tenets of TSN are formed. TSN requires international cooperation in order to achieve global maritime security. Furthermore, this cooperation must be mutual where the participants are bound by the universal interest of security, stability, and economic prosperity. This mutual interest allows for partnerships to be formed voluntarily, with the intent of building trust and reciprocal actions of support. To foster trust, TSN employs a common and transparent method to react to transnational criminals and humanitarian need and environment governance. For example, potential best practices developed for a particular region are broadcast to TSN to enhance the effectiveness of any course of action. TSN is expected to provide situation awareness and foster C2 in order to enhance TSN effectiveness. As emphasized in the strategy, the sea is shared by nation-states, international and regional organizations, in addition to the private sector, each having commercial and non-commercial concerns (Woodson 2007). To be effective, TSN must be knowledgeable of these concerns and operate within these confines.

Mutual interest is envisioned to compel a new kind of global alliance for which objectives and tenets appear to be unprecedented. Both the U.S. Department of State and USMC/USN/USCG community strategies are expected to assure economic prosperity of the global economy. From the U.S. point of view, 95 percent of trade is transported by sea. This comprises 20 percent of the Gross [Domestic] National Product (GNP) in 2000. Although parameters differ, other nation-states have sea trade components with significant percentage of their GNP. The study by Looney, Schrady and Porch D (2001) on globalization illustrates how enhanced security of the maritime domain provides economic benefits for the global economy. Figure 3, from the study, illustrates the

expected benefit of naval presence and globalization hypothesized for the U.S., yet it seems equally applicable for all nation-states vested in the global market place.

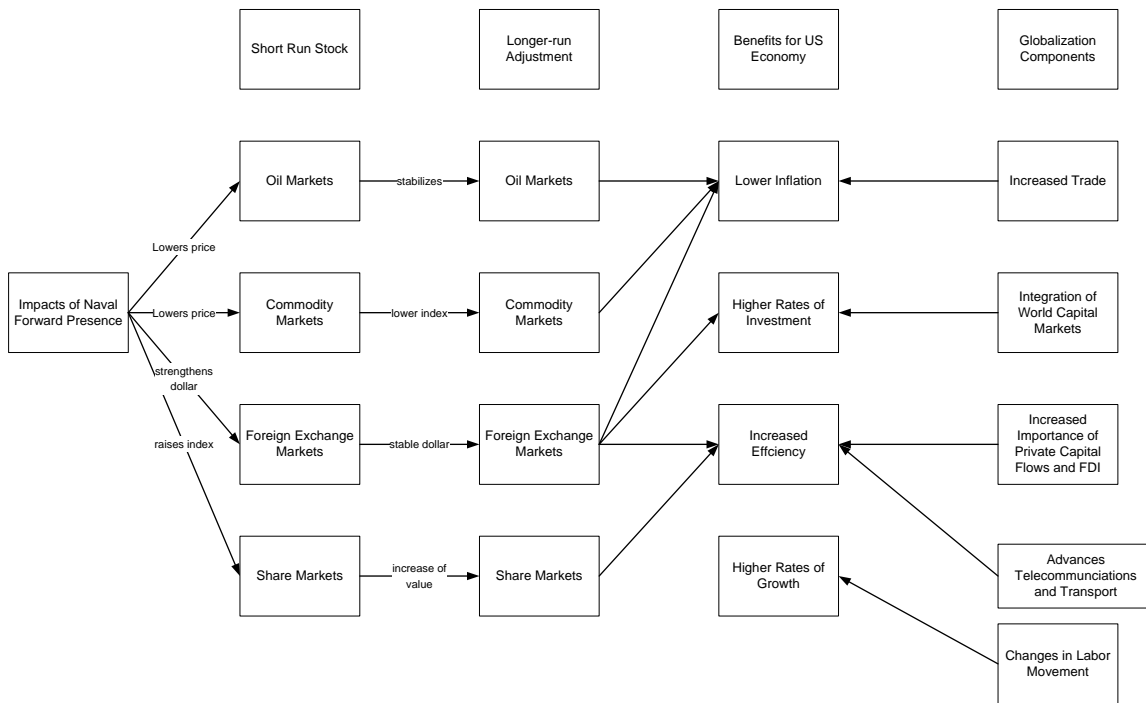

Figure 3. Naval Presence and Globalization (Looney, Schrady and Porch 2001).

Study of four specific instances of naval presence / crisis response suggests that both globalization and naval forward presence strongly correlate.

With the prospect of a stable and secure free trade, economic benefits provide strong motivation to participate in an alliance, TSN (Looney, Schrady and Porch D 2001). Maritime security is essential to U.S. economic interests during the projected shift of economic dominance to the Association of Southeast Asian Nations (ASEAN), Japan, South Korea, Taiwan, Singapore, Hong Kong and China, (Cronin 2009).

3. Global Fleet Station and TSN

GFS is an implementation concept embracing the U.S. Department of State and USMC/USN/USCG community strategies. Essentially, the concept employs USN ships and other U.S. government assets as a self sustaining base from which to conduct

maritime operations. Training, humanitarian assistance, maritime interdiction and combat span the range of possible options. The GFS unit is a dedicated combat command asset with a primary mission to support security objectives by working directly with other services and interagency components to develop and sustain regional partnerships (Adkins 2008). Validation of GFS is found in Department of Defense Directive (DoDD) 3000.05 Military Support for Stability, Security, Transition, and Reconstruction (SSTR) Operations (U.S. Department of Defense 2005). This directive outlines policy objectives which support the broader goals of the U.S. Department of State International Outreach and Coordination Strategy for the U.S. National Strategy for Maritime Security. Regardless of the eventual GFS-TSN association, the policy objectives are useful for guiding the development of supporting TSN C4I systems.

The following DoD 3000.05 stability operations policy objectives are selected based on their C4I system implications and compatibility with the U.S. Department of State International Outreach and Coordination Strategy for the U.S. National Strategy for Maritime Security, and CNO Admiral Mullen, USN advocated TSN concept. A concept that thwarts transnational threats, provides humanitarian assistance, responds to disaster relief events, and provides environment governance.

[4.4] “Integrated civilian and military efforts are key to successful stability operations. Whether conducting or supporting stability operations, the Department of Defense shall be prepared to work closely with relevant U.S. Departments and Agencies, foreign governments and security forces, global and regional international organizations (hereafter referred to as “International Organizations”), U.S. and foreign nongovernmental organizations (hereafter referred to as “NGOs”), and private sector individuals and for-profit companies (hereafter referred to as “Private Sector”)” (U.S. Department of Defense 2005).

[4.12] “Information shall be shared with U.S. Departments and Agencies, foreign governments and forces, International Organizations, NGOs, and the members of the Private Sector supporting stability operations, consistent with legal requirement” (U.S. Department of Defense 2005).

4. Piracy and Humanitarian Aid Concerns

The 21st Century Maritime Strategy (U.S. Department of Navy 2007), USMC/USN/USCG community, consists of not only the reactive approach to fighting wars and terrorism, but also a proactive approach to preventing them. “Today regional conflict has ramifications far beyond the area of conflict. Humanitarian crises, violence spreading across borders, pandemics, and the interruption of vital resources are all possible when regional crises erupt” (U.S. Department of Navy 2007). The coordinated, forced delivery of humanitarian aid is a proactive approach to prevent human suffering that which otherwise would escalate to dysfunctional societal behavior.

Human suffering cannot be completely prevented since it can be created “through catastrophic storms, loss of arable lands, and coastal flooding [which] could lead to loss of life, involuntary migrations, social instability, and regional crises” (U.S. Department of Navy 2007). The USMC/USN/USCG community strategy intends to minimize instability and regional crises. If no country provides assistance,

“mass communications will highlight the drama of human suffering, and disadvantaged populations will be ever more painfully aware and less tolerant of their conditions. Extremist ideologies will become increasingly attractive to those in despair and bereft of opportunity. Criminal elements will also exploit this social instability” (U.S. Department of Navy 2007).

Cyclone Nargis, which struck Myanmar in 2007 affected 2.4 million people. The food, water, and medical supply needs for Myanmar were more than any single nation could provide. Although international humanitarian assistance was initially rejected by the Burmese government, after relief efforts began the ASEAN Emergency Rapid Assessment Team noted that a coordinating platform was required to effectively help the victims (The Association of South East Asian Nations 2008).

Somalia is a country in chaos and a failed state. The lack of sustained, effective humanitarian assistance has fostered the rise of piracy in the Gulf of Aden. Pirating has turned into a multi-million dollar industry that provides income to the country. In 2008, Somali pirates received over 150 million US dollars in ransoms. Sugule Dahir, a clothing shop owner from Eyl, Somalia noted that shops and businesses are booming due to

supplemental income provided by piracy further stating that people are happier than before (Kennedy and Mohamad 2008).

Pirates do not discriminate nor differentiate between, illegal fishers, commercial transports, or aid delivering ships. One such event transpired in April of 2009 involving the MV Liberty Sun, a U.S. food aid ship. Pirates attacked the unescorted ship with rockets and gunfire forcing the crew to lock themselves in the engine room until the arrival of the USS Bainbridge DDG-96 (Jones 2009). By contrast, ships carrying aid that were accompanied by European Union naval escorts during the same period arrived without incident (Nyakairu 2009).

“Since November last year, a succession of Canadian, Dutch, Danish and French frigates have been escorting [World Food Program] WFP ships without incident, delivering a total 136,500 metric tons of food – enough to feed 2.6 million people for three months” (Marshall 2008).

Piracy precipitated the international community to coordinate efforts and provide armed escort to ships laden with humanitarian aid as an immediate and practical measure to mitigate the transnational threat.

5. Unconventional Operations: the “Soft Navy”

Although the USN sails worldwide to demonstrate its naval presence and power, it also performs seaborne rescues and provides both humanitarian relief and civil support. The “Soft Navy” encompasses these supporting efforts which bolster U.S. State Department policy and joint USMC/USN/USCG community strategy. Through these actions, the U.S. can improve its diplomatic posture with other nations, such as China that is reemerging as an economic and naval power. Similar to forced humanitarian aid, “Soft Navy” humanitarian aid requires an internationally coordinated effort.

Prime examples of “Soft Navy” operations are the recent activities of hospital ships USNS Mercy T-AH-19 and USNS Comfort T-AH-20. Both ships have provided medical services to impoverished and disaster stricken countries. In 2007, Comfort treated more than 98,000 people in 12 countries during a four month mission named Partnership for the Americas. Medical professionals from the USN, USAF, USCG and

Public Health Service, as well as Canadian troops and civilian volunteers from a number of nonprofit organizations staffed the hospital ship (Ware 2009). Comfort also conducted Continuing Promise 2008 and 2009 missions which are continuing efforts from Partnership of the Americas. The ship transported personnel from several Non-Government Organizations (NGOs) including: Food for the Poor, International Aid, Latter Day Saints Ministries, Operation Smile and Project Hope (Marshall 2009).

The humanitarian support from USN ships goes beyond medical facilities and support:

- USS Abraham Lincoln CVN-72 was outfitted to supply potable water to the tsunami victims during Operation Unified Assistance 2008, providing over 5000 gallons of water within the first two days of reaching port (Stutz 2005).
- USS Fulton AS-11 furnished electrical power to the stricken island of Guam from 13 to 21 November after Typhoon Karen, on 11 November 1962. The ship's sick bay was used as a hospital; five babies were born on board during this period (Siegel 2003).
- After the San Francisco earthquake in October of 1989,

“[a] variety of Naval forces provided relief services, with a total of 24 U.S. Navy and Military Sealift Command ships rendering assistance. LHA-5 Peleliu provided shelter for 300 victims and provided helicopter support. FF-1060 Lang provided steam for power generation, FF-1054 Gray provided electric power, CGN-39 Texas provided communications support. Helicopter detachments supporting relief efforts flew from AOR-3 Kansas City and AE-32 Flint, and Marines from the LST-1185 Schenectady aided local relief efforts” (Siegel 2003).

From the U.S. perspective, the TSN C4I must include USN, USMC, and USCG community interacting and operating with foreign nations’ navies, constabulary forces, non-government organizations, private industry, and individuals to secure the maritime domain and provide assistance when needed. “We [the U.S.] cannot be everywhere, and we cannot act to mitigate all regional conflict” (U.S. Department of Navy 2007).

Currently with a fleet of less than 300 ships, the U.S. does not have the maritime resources to even consider fulfilling this role single handedly.

“Consistent with the National Fleet Policy, Coast Guard forces must be able to operate as part of a joint task force thousands of miles from our shores, and naval forces must be able to respond to operational tasking close to home when necessary to secure our nation and support civil authorities. Integration and interoperability are key to success in these activities, particularly where diverse forces of varying capability and mission must work together seamlessly in support of defense, security, and humanitarian operations” (U.S. Department of Navy 2007).

Coordination of these operations requires a trust that is developed by consistent application of soft navy operations.

Currently, China is expanding its naval power with the ambition to perform “Soft Navy” operations. China has produced a naval hospital ship, dubbed Ship 866. Although it has military functions, if operating like USN hospital ships, 99 percent of its time and resources are available for humanitarian aid operations. China has shown the capability to protect the waters from terrorism, pirating, and illegal trafficking by venturing into the pirate-infested waters at the Gulf of Aden in December of 2008. Senior Colonel Huang Xueping, spokesman of the Ministry of National Defense, noted China’s willingness “to share intelligence and conduct humanitarian rescue operations with other countries involved in the anti-piracy efforts” (Barrowclough 2008).

B. STAKEHOLDER ORGANIZATIONS

In the TSN concept, stakeholders having vested interests in the concept are partitioned into several categories as shown in Figure 4. These categories include: commercial manufacturers, nations’ constabulary forces, nations’ navies, private vessels, the commercial shipping industry, humanitarian aid organizations, and international maritime organizations and partnerships.

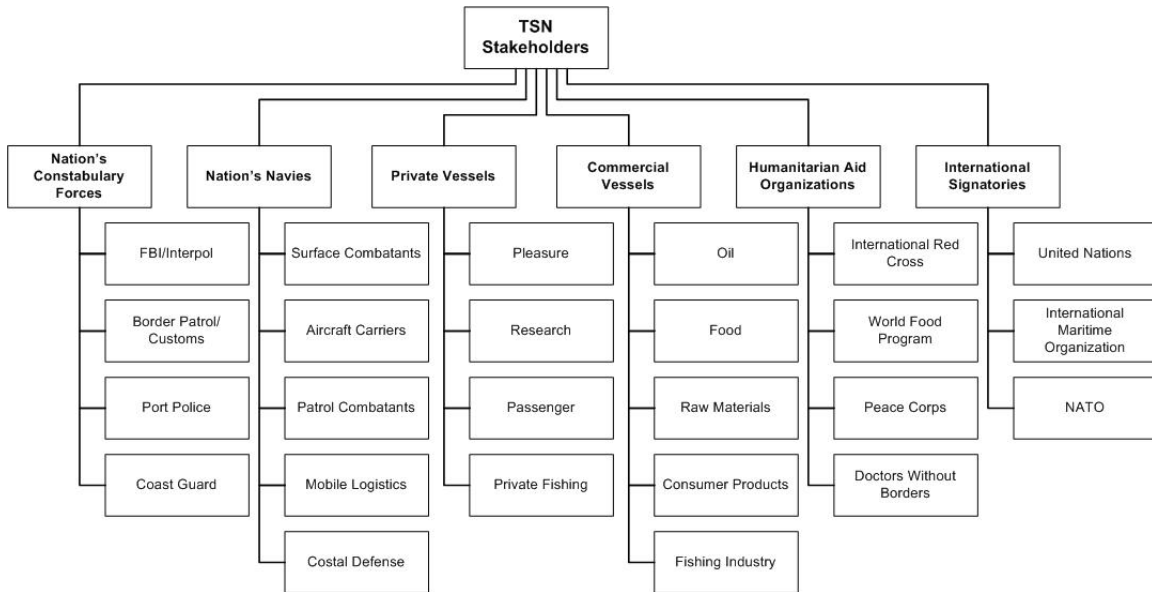

Figure 4. TSN Stakeholder Taxonomy.

The TSN stakeholders are international, national, commercial, and private partners.

1. Authorities Having Legal Jurisdiction

International waters, those waters beyond territorial waters, are currently governed by two legal fields: private and public international law (Cornell University Law School, International). Private international law deals with legal issues between at least two private parties, such as shipping companies from different countries as well as issues between private parties and sovereign nations or international organizations. As part of private law, Admiralty law is concerned with maritime matters such as navigation, passengers, and goods at sea. Normally in private international law, a court must first decide if it has jurisdiction, then must decide which nation's laws apply. Admiralty law is unique in that the ship's flag determines the jurisdictional authority (Cornell University Law School, Admiralty). International treaties established by the UN's International Maritime Organization (IMO) fall under the scope of Admiralty law which include: International Convention for the Safety of Life at Sea, 1974, International Convention on Maritime Search and Rescue, 1995, International Convention for the Prevention of Pollution from Ships 1973, 1978, Convention for the Suppression of Unlawful Acts Against the Safety of Maritime Navigation, 1988, and International Convention on Standards of Training, Certification, and Watchkeeping for Seafarers, 1978 (International

Maritime Organization, List of Conventions). Shipping companies that are flagged to nations that have signed these treaties must adhere to Admiralty laws while underway.

Public international law deals with legal matters between at least two sovereign states or a sovereign state and an international body. The United Nations Convention on Laws of the Sea, 1982 (UNCLOS III) is the predominant treaty for public international law. Its 320 articles define “all aspects of ocean space, such as delimitation, environmental control, marine scientific research, economic and commercial activities, transfer of technology and the settlement of disputes relating to ocean matters” (United Nations 1982). Particularly important to this study is Part 7, Section 1, Articles 86 through 115, which define conduct on the high seas. Article 98 states a vessel must render assistance by proceeding “with all possible speed to the rescue of persons in distress, if informed of their need of assistance, in so far as such action may reasonably be expected” (United Nations 1982). The U.S. Judge Advocate General’s (JAG) Operational Law Handbook clearly states that

“ships and, under certain circumstances, aircraft have the right to enter a foreign territorial sea or archipelagic waters and corresponding airspace without the permission of the coastal state when rendering emergency assistance to those in danger or distress from perils of the sea” (Anderson and Zukauskas 2008).

These principles and legal constructs are supportive of cooperation in previously disputed waters and provide a positive foundation for TSN.

In addition to these issues, transnational threats on the high seas such as piracy, illicit drug trade, and traffic in persons are also defined in this part. Section 1 Article 100 requires all ratifying states to “cooperate to the fullest possible extent in the repression of piracy on the high seas or in any other place outside the jurisdiction of any State” (International Maritime Organization, List of Conventions). Articles 101 through 107 deal with piracy, the seizure of ships suspected of piracy, and which ships or aircraft are entitled to carry out the seizure. Article 110 governs a warship’s right to board a foreign vessel suspected of committing a crime on the high seas and Article 111 defines a nation’s right of hot pursuit of that vessel or aircraft from its territorial waters to the high seas. U.S. forces are explicitly obligated by JAG to “repress piracy on or over

international waters directed against any vessel or aircraft, whether US or foreign flagged,” based upon “the right and obligation of unit self-defense extend[ing] to the persons, vessels or aircraft assisted” (Anderson and Zukauskas 2008). The prevention of illicit drug trafficking is covered in Article 108. Much like when a vessel requests assistance, it requires that all States must “cooperate in the suppression of illicit traffic in narcotic drugs and psychotropic substances engaged in by ships on the high seas,” (United Nations 1982). Furthermore the combined international effort to outlaw traffic in persons, i.e. slavery, is outlined in Article 99. Although the U.S. government has not ratified the treaty, it does abide by its provisions. UNCLOS III relies heavily on international cooperation, a fundamental attribute of TSN.

2. Constabulary Forces

Although a large portion of the detection component of the TSN C4I system is conducted on private and commercial based platforms, the fundamental roles of enforcement, deterrence, and mitigation must also be accomplished. In territorial waters, these functions are most appropriate for a nation’s constabulary forces – such as the FBI, INTERPOL, border patrol, port police, and coast guards. To develop the C4I system, these forces must satisfy their user community’s expectations regarding response to transnational threats. The input from this community helps develop buy-in for participation and provides baseline national capabilities to address transnational threats. This baseline information supplements the TSN C4I system by declaring available resources at the regional and global level.

3. Nations’ Navies

The stakeholder primarily concerned with participation within TSN is the one tasked with providing force mitigation. These missions are accomplished by nations’ navies through the international C4I capability offered by the system. This stakeholder community is also the most sensitive with regard to information sharing and capability disclosures given the need to protect national capabilities from undue disclosure, the complexity of international relationships, and a continually changing political climate. Regardless, past performance indicates that nations’ navies answer the call for

humanitarian aid when needed. A primary tenet of TSN is that navies volunteer not only to provide force but also humanitarian aid in response to a large scale disaster. The feedback and buy-in of this community is vital to providing TSN with authenticity ensuring its effectiveness. Without naval intervention, at risk vessels are subscribing to private security agencies to address the transnational threat. There are concerns that this method only increases violence on the high seas. According to Senator John Rockefeller, “providing protection for U.S. ships from pirates should be the responsibility of the U.S. military. Arming ship crew members is not an option he said, disagreeing with several of those testifying” (McConnell 2009).

4. Private Vessels

Non-military-based detection is a key capability of the TSN C4I solution. Representing a significant population of sea faring vessels, it is logical to leverage the private community to supplement the situational awareness inputs of the TSN C4I system. Legacy onboard technologies, such as Automatic Identification Systems (AIS), Long Range Identification and Tracking (LRIT) systems, surface ship radar, marine band Very High Frequency (VHF) transceivers, Global Maritime Distress Safety System (GMDSS), INMARSAT, and NAVTEX are in use aboard pleasure craft, research vessels, and passenger liners. These technologies and others are developed internationally and further facilitate the detection of transnational threats or disasters thereby increasing the TSN situation awareness capacity and effectiveness.

5. Commercial Shipping and Fishing

The intent of the TSN C4I system is to provide the means by which responses to transnational threats and large-scale disasters can be coordinated. As the shipping industry is in the business of transporting oil, food, raw materials, and customer products between nations and economies, it is vital that risks are managed to ensure economic freedom. A C4I system solution that mitigates transnational threats inherently limits risk to the industry thereby decreasing insurance cost. To this end, the shipping industry represents a principal user of the TSN C4I system. Their input facilitates and influences the design of the shipboard user interface and increases the probability of valid reporting.

6. Humanitarian Aid Organizations

Humanitarian aid organizations also must be included in the TSN stakeholder community. This group is primarily composed of NGOs, such as International Red Cross, World Food Organization program, Peace Corps, and Doctors Without Borders. The community of international humanitarian aid organizations is concerned with logistics pipeline issues and processes that TSN must address. According to ASEAN, the support necessary after a large scale disaster includes: temporary shelters, sanitation facilities, hygiene kits, building materials, potable water, health infrastructure, and food security (The Association of South East Asian Nations 2008).

7. International Organizations and Partnerships

Another tenet of TSN is that politics should be apparent in order to maximize maritime situation awareness and threat mitigation. To accomplish this, TSN relies heavily on international signatory organizations such as, the IMO, International Chamber of Commerce's (ICC) International Marine Bureau (IMB), NATO, etc. These organizations participate in establishing, empowering, and enforcing legal and technological definitions and standards that will enable TSN interoperability. Noted in the ASEAN report is a key recommendation for "a coordinating platform for relief and recovery strategies" that "involve[s] key partners who...enhance coordination and information sharing" (The Association of South East Asian Nations 2008). Most critically, these organization and partnerships are responsible for developing clear and concise demarcations of roles and responsibilities that enhance coordination and information sharing.

The IMB created in 1992 a prototype of the GMP. With voluntary funding the IMB's Piracy Reporting Center (PRC) aimed to be the "first point of contact for the shipmaster to report an actual or attempted attack or even suspicious movements" (International Chamber of Commerce, Commercial Crime Services, IMB Piracy Reporting Centre). Prior to its creation, there was no timely way for ships under attack to request help from law enforcement. The attacked ships were forced to broadcast distress signals and verbally relay their coordinates and type of emergency to accessible law

enforcement agencies; thereby consuming valuable response time. Furthermore, other ships in proximity of the crime area were put at risk due to the lack of information sharing regarding piracy threats.

PRC communicates with ships via fax, email, or satellite phone giving their location and nature of emergency to the PRC headquarters located in Kuala Lumpur, Malaysia. PRC relays the ship's information to local law enforcement as well as publishes the location and type of attack on the PRC website. Additionally, the information is formatted for distribution via various data exchange systems. PRC has achieved recognition for mitigating piracy attacks and generating awareness of the problem (International Chamber of Commerce, Commercial Crime Services, IMB Piracy Reporting Centre).

C. EXISTING ARCHITECTURES AND SYSTEMS

Currently, there are several fielded information architectures and systems that provide regional information sharing and should provide input to TSN. However despite their successes, these architectures and systems cannot independently accomplish all of the TSN tenets for various reasons. Five examples are Maritime Domain Awareness, FORCEnet, the Combined Enterprise Regional Information Exchange System, the Global Information Grid, and Caspian Guard.

1. U.S. Maritime Domain Awareness

Maritime Domain Awareness (MDA) is the effective comprehension and response to all information associated with the global maritime environment that could impact the security, safety, economy, or environment of the United States. The National Concept of Operations for MDA has created individual hubs that are responsible for managing information of four separate categories: vessels, cargo, people, and infrastructure. There is an additional hub within MDA tasked to design and manage the architecture that enables sharing of the maritime information among the Global Maritime Community of Interest (COI). The National Plan to achieve MDA for the National Strategy for Maritime Security states: "The heart of the Maritime Domain Awareness program is accurate information, intelligence, surveillance, and reconnaissance of all

vessels, cargo, and people extending well beyond our traditional maritime boundaries” (U.S. Department of Homeland Security 2005). This information needs to be accessed quickly and released to appropriate active MDA participants.

2. U.S. Navy

a. FORCENET

Sponsored by the USN, FORCEnet is an ongoing research and development framework that focuses on developing software products that enable MDA. This project comprises four projects: Department of Navy Transformation within Department of Defense Framework (Strategic Planning), Accelerating Joint Warfighting Capability (Trident Warrior), Implementing FORCEnet Requirements (FORCEnet Compliance), and Systems Requirements Analysis/Systems Engineering (formerly Osprey Hawksbill). The lifetime of this effort is 10 years beginning in FY09. “FORCEnet functionality is a subset of battle force functionality that can contribute to battle management, battlespace dominance, and sustainability” (National Research Council U.S. Committee on FORCEnet Implementation Strategy 2009). FORCEnet deals specifically with naval forces and does not offer support for humanitarian aid, making it unable to solely support all TSN tenets.

b. CENTRIXS

In an effort to support the Global War on Terrorism, the Combined Enterprise Regional Information Exchange System (CENTRIXS) was established. CENTRIXS maintains a shared, timely, common visualization of the battlespace with U.S. coalition and allied partners. Currently, CENTRIXS is used for time-critical information for combined warfighting including: operations and intelligence information for threat and battlefield awareness; mission requirements for integration and coordination of coalition forces; theater ballistic missile defense; nuclear, biological and chemical threat warning; regional military and civil air movement scheduling; battlefield campaign assessment data; force disposition, and combined force threat response data (Boardman and Shuey 2004). CENTRIX exchanges information on a single level of classification, which can be difficult to manage due to current data certification and

accreditation processes. Because of security restrictions and the requirement to certify the information, this system is limited to U.S. and its allied military forces.

c. Global Information Grid

According to the Department of Defense Global Information Grid Architectural Vision for a Net-Centric, Service-Oriented DoD Enterprise,

“the Global Information Grid (GIG) consists of information capabilities that support Department of Defense (DoD) personnel and organizations in accomplishing their tasks and missions – that enable the access to, exchange and use of information and services throughout the Department and with non-DoD mission partners” (U.S. Department of Defense Chief Information Officer 2007).

GIG accomplishes this mission using an Internet Protocol (IP)-based infrastructure; which, in addition to being standardized, is widely used and accepted. GIG operates by utilizing major DoD programs such as terrestrial networks, mobile IP networks, space-based laser communications, and teleports which link the ground and space segments together. Example GIG systems include Joint Tactical Radio system and canceled Transformation Satellite Communication program. However, “there will always be new performance and security requirements that cannot be met in the short transitional term by GIG” (U.S. Department of Defense Chief Information Officer 2007). TSN’s interoperability function should allow for the sharing of information with external networks and compensate for real time shortfalls.

d. Caspian Guard

The Caspian Guard’s primary objective is to provide maritime surveillance in the Caspian Basin and “patrol the oil-rich inland sea” (Cummins 2006). To accomplish this objective, the DoD assists Azerbaijan and Kazakhstan in the development of air and ground surveillance capabilities. Caspian Guard offers national-level command, control communications and intelligence, in addition to land border control and monitoring. This region is of particular interest to the U.S. due to the explosive growth of Kazakhstan’s oil infrastructure in the Caspian Sea Region. TSN C4I is intended to be compatible with Caspian Guard by interfacing additional surveillance

and patrol systems. Caspian Guard's biggest barrier is the region's political climate. It is perceived by Russia as a military force that generates animosity toward U.S.

D. DATA EXCHANGE SYSTEMS

Current legacy data exchange systems provide maritime awareness to users, commanders, and decision makers only in specific regions and alliances. These systems are often employed by commercial shipping companies and harbor masters to monitor coastal marine traffic and other high density areas at sea. They include both commercial and military systems that supply one or a combination of the following features: LRIT, automatic identification, situation awareness, piracy reporting, and hazardous spill reporting. While these disparate systems provide useful services, none are tailored specifically to meet the needs of an emergency response or humanitarian aid assistance. Listed below are descriptions of useful constabulary, commercial, and military data exchange systems.

1. Automatic Identification System

Maritime data exchange systems typically fall into one of two overarching system architectures typified by AIS or LRIT. AIS is the premiere non-combatant ship identification, tracking, and navigation system architecture in territorial waters. AIS systems autonomously and continually broadcast information such as “ship name, course and speed, classification, call sign, registration number, [Mobile Maritime Service Identity] MMSI, and other information” (U.S Coast Guard – Navigation Center 2009) to the coastal authorities at intervals defined by the IMO's Maritime Safety Committee. In U.S. territorial waters, AIS systems utilize two dedicated marine VHF channels for transmission, AIS1 and AIS2 (U.S. Coast Guard – Navigation Center 2009).

2. Long Range Identification and Tracking

LRIT is essentially a long range version of AIS. LRIT is a requirement for the following non-combatant vessels on international voyage: “passenger ships, including high-speed craft; cargo ships, including high-speed craft, of 300 gross tonnage and upwards” (International Maritime Organization, Long Range Identification and

Tracking). As defined by Safety of Life at Sea (SOLAS), these vessels' LRIT systems must transmit at a minimum: "the ship's identity, location, and date and time of the position" (International Maritime Organization, Long Range Identification and Tracking).

The fundamental difference between LRIT and AIS

"apart from the obvious one of range, is that, whereas AIS is a broadcast system, data derived through LRIT will be available only to the recipients who are entitled to receive such information and safeguards concerning the confidentiality of those data have been built into the regulatory provisions" (International Maritime Organization, Long Range Identification and Tracking).

Additionally, this information is not accessible to foreign coastal authorities that are in excess of 1000 nautical miles from the ship (International Maritime Organization, Long Range Identification and Tracking).

3. SafeSeaNet

SafeSeaNet (SSN) is a European Union developed, computer based AIS application that is tasked primarily with reducing maritime pollution and accidents in European coastal waters. It is intended to increase maritime domain awareness between cargo ships over 300 tons, as prescribed by SOLAS, 1974, and local port masters. SSN relies on a distributed database via a central index system. This database utilizes a composite of radio frequency methods and internet technology for data exchange from ship to land (Bergot, Hardy and Marcellus 2004). The robust application relays pertinent information such as position, type of accident, and souls on board to the database; which is then shared across the entire network. However, the main obstacle preventing SSN from being reused for TSN is its network security architecture. SSN relies on secure Trans European Services for Telematics between Administrators (S-TESTA), which is similar to SIPRNET in usage. S-TESTA is used to exchange data internationally between foreign ministries and is exclusive to the European Union (Bergot, Hardy and Marcellus 2004). Additionally, SSN is not specifically tasked to address piracy or other crimes at sea.

4. ShipLoc

ShipLoc is a satellite communications and computer based LRIT application developed in Europe. ShipLoc is operated and maintained by a subsidiary of the French Space Agency, Collectè Localisation Satellites (CLS). It is the official ship-security system of IMB's ICC and is employed specifically to combat piracy. ShipLoc utilizes satellite communications to relay distress information from ships to a land based processing center. From there, the information is disseminated and relayed to the ship owner, IMB, and the flag state authority via Internet, facsimile, and phone. It can also be used to monitor a ship's progress every hour or every four hours during normal operation. This data exchange system handles piracy extremely well, but does not address the other key areas of TSN. Further hindering its use, ShipLoc does not automatically alert nearby naval forces. Once an alert is triggered and relayed to the flag state authority, it is up to that authority to alert nearby naval forces through traditional military channels (Collectè Localisation Satellites). This process must be expedited in order to prevent hijackings similar to the Maersk Alabama in April, 2009.

5. Global Justice Information Sharing Initiative

The Global Justice Information Exchange is a U.S. developed data exchange standard that shares "pertinent justice and public safety information" between "the spectrum of law enforcement, judicial, correctional, and related bodies" (U.S. Department of Justice 2009). In development since 1998, the standard is used by The International Justice and Public Safety Information Sharing Network which includes as members INTERPOL, U.S. Department of Homeland Defense, and many others. As currently developed, the USCG uses the system and standard to share missing boat information. Predominantly a means to share information between law enforcement agencies, the standard may be extended for particular needs. It is conceivable that a future extension of this standard could facilitate information sharing between the USN and USCG, fulfilling a joint law enforcement related mission. Although currently limited, the standard is positioned for international use, with INTERPOL as an existing user.

6. Joint C3 Information Exchange – Multilateral Interoperability Programme

NATO's Joint C3 Information Exchange – Multilateral Interoperability Programme (MIP) is a military data exchange system that “enables information exchange between co-operating but distinct national C2 systems” (Multilateral Interoperability Programme 2009) “from corps to battalion or the lowest appropriate level, in order to support combined and joint operations and pursue the advancement of digitization in the international arena, including NATO” (Multilateral Interoperability Programme 2009). MIP uses a common interface, the Land C2 Information Exchange Data Model, to relay “essential battle-space information” and achieve this interoperability goal (Multilateral Interoperability Programme 2009). The information passed across a full MIP network is “situational awareness (including *inter-alia*, capabilities, and status of friendly and enemy forces), plans and orders, and nuclear biological chemical alerts and critical messages” (Multilateral Interoperability Programme 2009).

Unfortunately, because this system relays confidential military data, specifically situation awareness and critical messages, this data exchange system in its current form cannot be used by TSN C4I. It is unwise to share position information of naval forces with the commercial and private maritime community. Blindly broadcasting this information puts naval vessels, regardless of nationality, at risk to terrorist attack. It also puts commercial and private vessels at risk by displaying where forces are and essentially telling criminals where to commit their crimes.

The concern raised in this section illustrates the need for a new data exchange system. This new system must seamlessly relay critical information between naval and non-military vessels in a manner that does not undermine military confidentiality, while providing a rapid response to crimes at sea and reliable situation awareness communication during an emergency warranting humanitarian aid.

In summary, Chapter II discussed the historical origins of the TSN concept and its evolution over millennia. The effect of improved technology has limited battlespace volume where fewer ships are required to dominate any ocean. Subsequently, the

capability of a TSN in the modern era can be achieved with a fewer number of ships. TSN shifts from historical naval coalitions to an inclusive participatory and voluntary maritime alliance with an economic focus. Current non-military systems have solved some aspects of maritime security needs; however, a system is not in place to provide an integrated C4I capability to coordinate the transnational threat enforcement, humanitarian aid, and disaster relief/protect environment response missions. Complexities of TSN operations on the high seas, economic zones, and territorial waters require coordinating actions among the TSN stakeholders.

A paradigm shift from the GFS, the framework of TSN is based on an international framework vice a U.S. framework. Legacy systems which address maritime security fall into two categories. The first category is an adaptation of military systems, such as CENTRIXS and NATO's MIP Land C2. The second category includes commercial ventures and international organization systems, such as CLS's ShipLoc, AIS, and LRIT. Due to defense concerns, the first category is not viable for TSN. However, the second category is compatible with TSN as these systems are able to develop situation awareness enabling C2. Presently the PRC is the only multinational effort to alert law enforcement, ship masters, and owners of imminent transnational threats. A concern is that this capability does not have a dedicated humanitarian aid, disaster relief or environment governance mission.

Chapter III describes structured systems engineering methods, domain patterns, and analysis tools applied to develop requirements, define functions, and synthesize architecture alternatives. Chapter IV then describes the results from use of these systems engineering capabilities.

III. METHODOLOGY

Chapter III employs an applied systems engineering methodology to develop TSN C4I architectures and an information exchange standard for use with the architecture. Figure 5 summarizes the processes, methods, and tools used in this study.

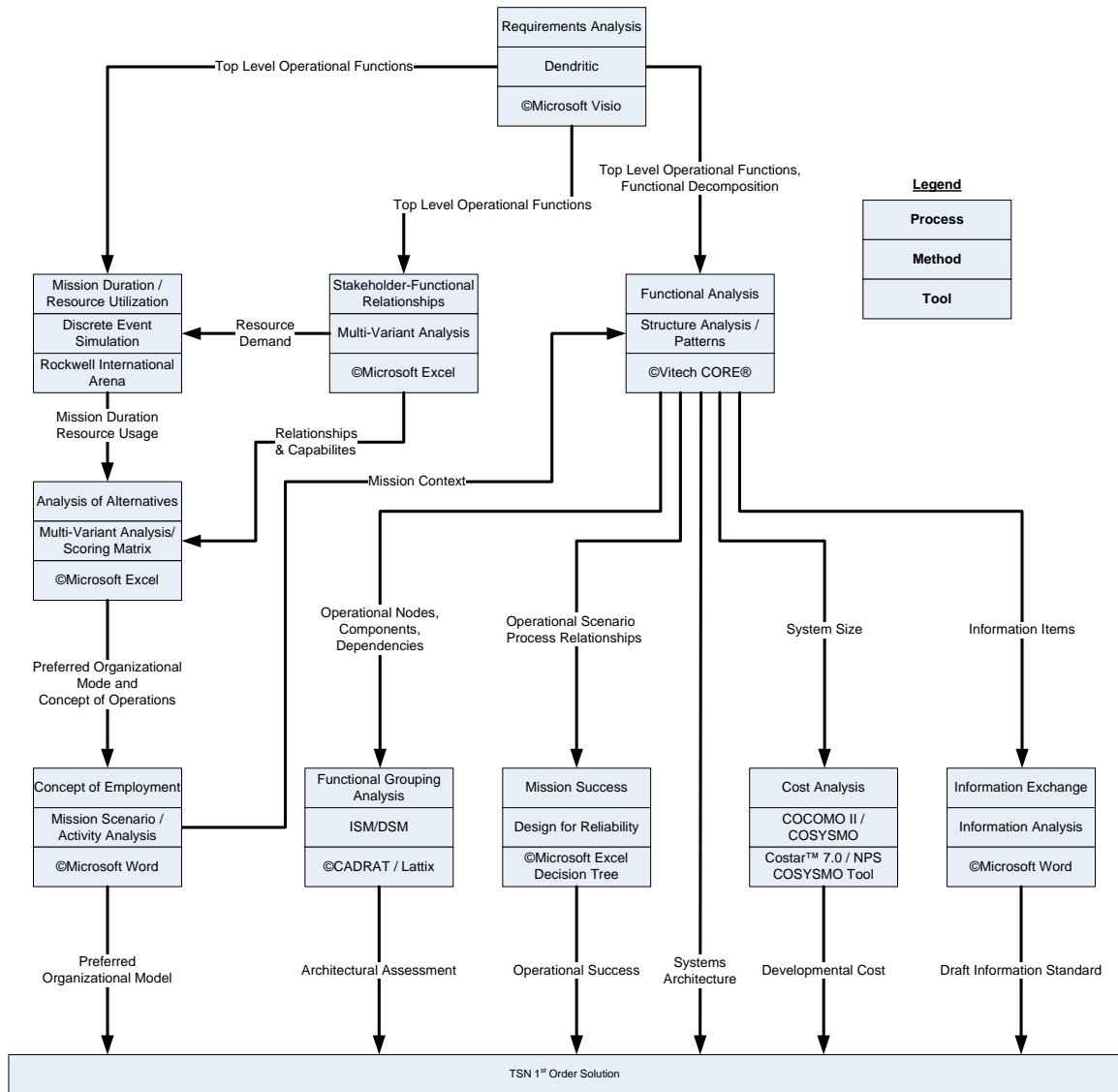

Figure 5. Summary of Process, Methods and Tools Used in this Study.

A combination of processes, methods, and tools are used in this study.

The employed systems engineering flow describes a problem space from which a solution is formed on the basis of Chapter II findings. A dendritic method is used to describe how TSN concerns are transformed to operational functions which form the foundation of subsequent operational and system domain analysis.

Operational concepts are investigated by performing a stakeholder organization AoA. The analysis evaluates human organization structures which restrict or constrain, TSN C4I solutions. Supporting the AoA a model based method analyzes TSN stakeholder and top level TSN operational functions addresses mission timing and stakeholder usage.

Operational and system domains are analyzed using mission analysis, functional analysis, interpretive structural matrix analysis, design structure matrix analysis and development cost estimation methods. Chapter III describes the basis of each method and how the methods interact. The objective of these methods is the development of architectures, information exchange requirements, and corroborating analyses the results of which results are provided in Chapter IV.

A. REQUIREMENTS DEVELOPMENT AND FUNCTIONAL ANALYSIS

Chapters I and II have set forth the problem statement for this study and presented the requirements for a solution. The next step in this study is to transform the top level requirements into a set of operational functions. In establishing these functions, a dendritic model is utilized to organize and group TSN C4I operational functionality. The model serves as the unifying product for subsequent analysis and solution development. ©Microsoft Visio is employed to develop and manage the dendritic structure leveraging basic shapes and connection point functionality to allow for the greatest flexibility in layout.

The dendritic model is based on a parent-child data structure which decomposes level-one operational functions into multiple constituent functions. The directed relationships, or logic flow, progresses from left to right beginning with a general parent function which is then derived into specific child functions. Figure 6 portrays an example of the dendritic model with generalized titles.

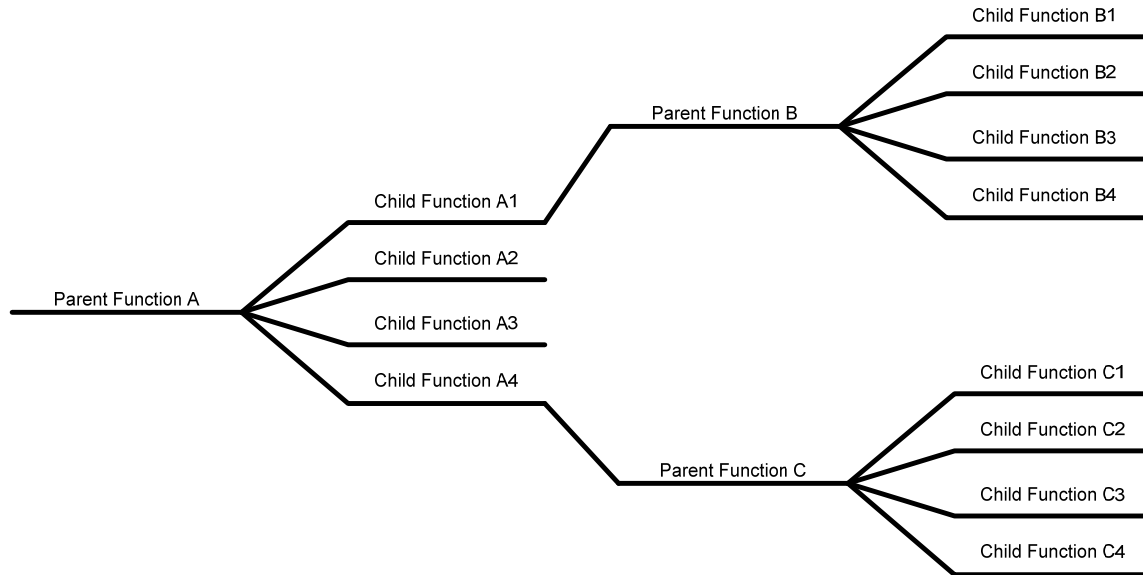

Figure 6. Functional Dendritic Model.

The dendritic model provides a structure for organizing top level operational functions.

The application of the dendritic model produces multiple paths. Similar to a tree structure (Buede 2000), the dendritic model also employs strata of organization. This organization attempts to maintain the level of the functional abstraction consistent across the dendritic structure. This consistency implies that each of the child functions, *B1-B4* and *C1-C4*, are of the same level of abstraction. Also, depending on user perspective, functions can be both a valid parent and child function. For example, *Parent Function B* is both the parent of all child functions *B1-B4*; as well as the child of *Child Function A1*.

A practical means to elicit and document top level TSN operational functions, the dendritic model provides the reference for subsequent analysis methods.

B. FUNCTIONAL MODEL AND DECOMPOSITION

Functional modeling is performed to describe the operational activities and system functions, or services, of the system. With the use of CORE® by ©Vitech Corporation, both Functional Flow Block Diagrams (FFBD) and Enhanced Functional Flow Block Diagrams (EFFBD) are developed to represent control logic and allocated functional behavior. The FFBD syntax provides four types of architecture/design patterns: series, concurrent, selection and multi-exit (Buede 2000). The EFFBD adds

three control patterns: iteration, looping, and replication. Additionally, data items may be added to the EFFBD that describe complex control and data. The typical use of the EFFBD is for the generation of timelines using discrete probabilistic duration values. These simulations provide a means to verify the consistency of the model as well as to develop temporal performance requirements. N by N (N^2), Integration Definition for Function Modeling (IDEF0), hierarchy and block diagrams are also rendered from the model.

Behavior and structure are associated by the use of relationships within the CORE® and CORE® tools. The allocation of behavior to structure is sufficiently flexible to allow the consideration of alternative structures where each structure represents an alternative architecture, component or service. The level of structure abstraction includes classification, interconnection, and aggregation (Keegan et al. 1997). Because behavior and structure models are related the models interrelate with static relationships and by means of the executable simulation. When properly modeled as multi-thread and multi-instance behavior, states of an object are described as executable models. In the operational domain, operational scenarios are described by this means. In the system domain, system scenarios are described by this means. In combination with the aforementioned diagrams, Department of Defense Architecture Framework (DoDAF) views are also generated.

CORE® is used to perform the functional modeling and simulation. The tool is provided with an extensible schema which establishes the relationship framework between the classes of model entities. As good practice this schema should be consistent with the purpose and limitations of the modeling scope. Figure 7 illustrates the use of the schema to meet the modeling objectives of the TSN study.

Shown in the color yellow are the classes and meta-relationships of the model entities used to describe the operational domain. This domain includes interrelated architectures, missions, and operational tasks with related operational nodes, operational activities, needlines, and operational requirements. Shown in color orange are the classes and meta-relationships of the model entities use to describe the system domain. This

domain includes interrelated system nodes, functions, interfaces, links, and functional requirements.

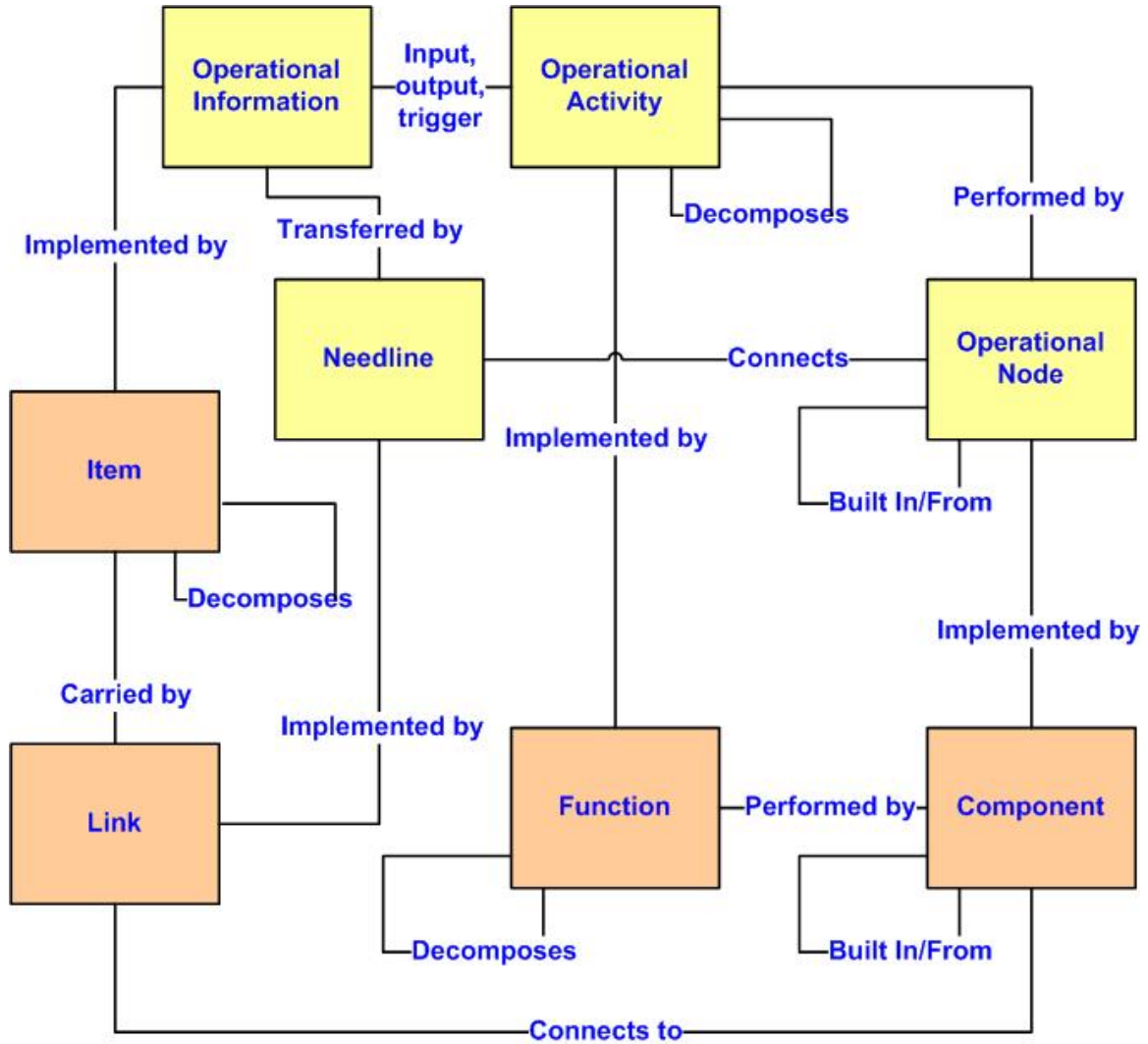

Figure 7. CORE® Schema Used for Modeling.

A subset of the default CORE® model schema is used for this study.

C. PATTERN METHODOLOGY

Pattern methodology is incorporated with functional modeling as a means to apply proven characterizations of the operational domain and system domain. Generally, a pattern is defined as “Anything proposed for imitation; an archetype; an exemplar; that

which is to be, or is worthy to be, copied or imitated; as, a pattern of a machine” (Bowler et al. 2009).

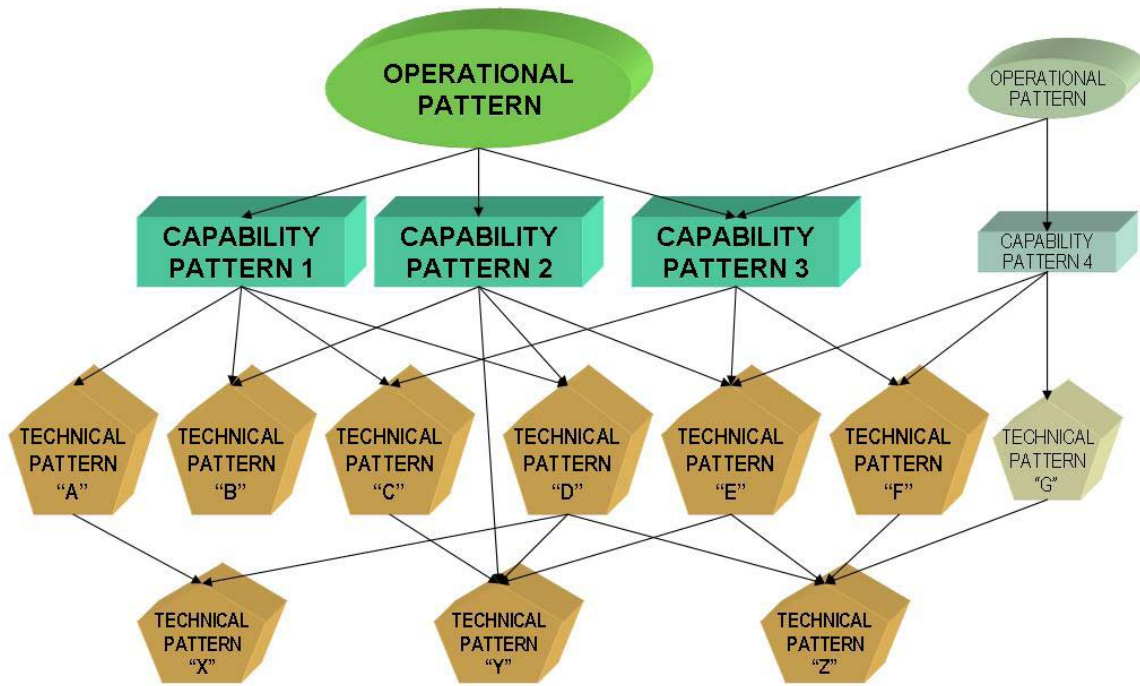

Figure 8. Top-Down Relationship Among Patterns (Bowler et al. 2009).

Operational, capability, and technical patterns are useful in architectural development.

The framework, Figure 8, shows the relationships between operational domain and system domain. The operational domain is composed of both operational patterns and capability patterns. Operational patterns represent recurring approaches for conducting activities, operational functions, in a given mission context. The system domain is composed of both capability patterns and technical patterns. Capability patterns represent recurring approaches that refine an associated operational pattern with organization types, use cases, process flows, and operational or system functions. Capability patterns occur in both the operational domain and system domain. The technical pattern describes design element arrangements that support associated capabilities (Bowler et al.2009).

TSN patterns are considered from DoD, law enforcement and commercial sources. Examining legacy systems in Chapter II provides insight to operational and capability patterns. To apply a pattern, the merits are evaluated for its adaptability in the

operational or system environment for which it is intended to be employed. In the case of TSN C4I, patterns are combined from multiple sources to leverage archetypes familiar to TSN stakeholders.

D. INTERPRETIVE STRUCTURAL MODELING ANALYSIS

Interpretive Structural Modeling (ISM) is a method developed in the early 1960s for representing complex relationships between nodes in a context. The basis of ISM is found in the theory of nets, relations, and directed graphs. The mathematical basis of ISM relies on matrix mathematics (Sage 1977). This method provides an objective score of operational node and system component functional clusters with insight into interface development.

Graphs allow the architect/designer to visualize the relationships between functions and components. The graphs are a formal representation of relationships among nodes in a set or pair where a node may represent a functional cluster or component. The concepts of adjacency and reachability are significant when developing operational and system architectures (Buede 2000). Both concepts represent a degree of connectedness, where technical patterns are made visible by the use of matrices.

Two matrices useful in ISM analysis are an adjacency matrix and a reachability matrix. The adjacency matrix is a representation of the structural node-to-node relationships. The reachability matrix represents outcomes when the resultant relationships are exercised with some undetermined number of steps to a steady state (Buede 2000). The reachability matrix is calculated from the adjacency matrix using Equation (1), where $R(A)$ is reachability matrix of A , $A(G)$ is adjacency matrix of G the incidence matrix, I is the identity matrix, and n is the length of paths (Sage 1977).

$$R(A) = [A(G) + I]^{(n-1)} \quad (1)$$

The ©Computer Assisted Design, Relationship Analysis Tool (©CADRAT) tool developed by Professor D. K. Hitchins uses an undirected incidence matrix to capture node-to-node relationships from a direction graph, Figure 9. The incidence matrix is

transformed into the directed adjacency matrix, similar in form to an N^2 diagram where the association flow is clockwise by use of Equation (2) (Diestel 2005).

$$A(G) = G_{(i,j)}^T G_{(i,j)} - 2I_q \quad (2)$$

$A(G)$ is the adjacency matrix of G ; $G(i,j)=(V,E)$ where V represents the vertices and E represents the edge of the incidence matrix, T means the transpose of the matrix and I_q is the identity matrix.

An extension of ISM analysis technique is the use of strength of association to represent the relative importance of one relationship to another. Higher numeric values correlate to more important associations, relative to another association. In Figure 9, node C is related to node D with an association strength of 2 and node B with an association strength of 9. Use of strength of association influences the clustering of nodes, where nodes associated with a higher number are more likely to be clustered by comparison to nodes that have a lower number (Hitchins 1998). The use of association values impacts the matrix score.

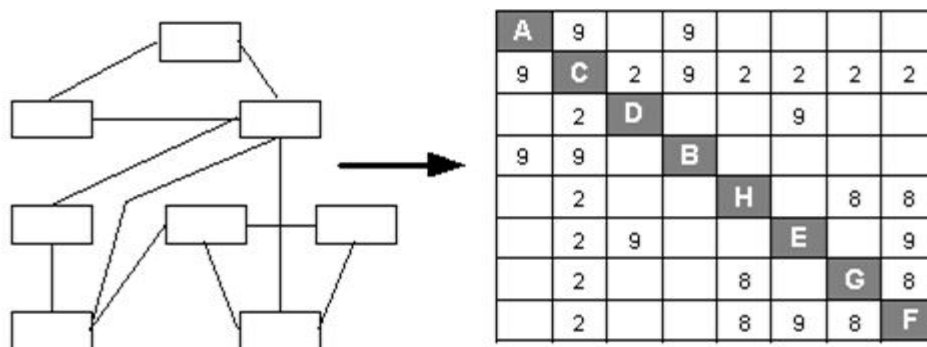

Figure 9. Digraph to Undirected Incidence Translation (Hitchins 1998).

The directed graph is converted to an incidence matrix where the points of incidence have strength of association.

To score a matrix, the distance of an association from its node is multiplied by the strength of association. In Figure 10, the distance is dx and the association strength is represented by X . The sum for each row is summed and the summation row is summed (Hitchins 1998). Lower scores are preferred since they represent optimum node cohesion

and coupling. In practice, some non-optimal solutions are accepted because of other considerations. In these cases, the score of the non-optimum arrangement is divided by the optimum arrangement to provide a factor greater than or equal to one. As the value approaches one, the architecture solution approaches optimum modularity.

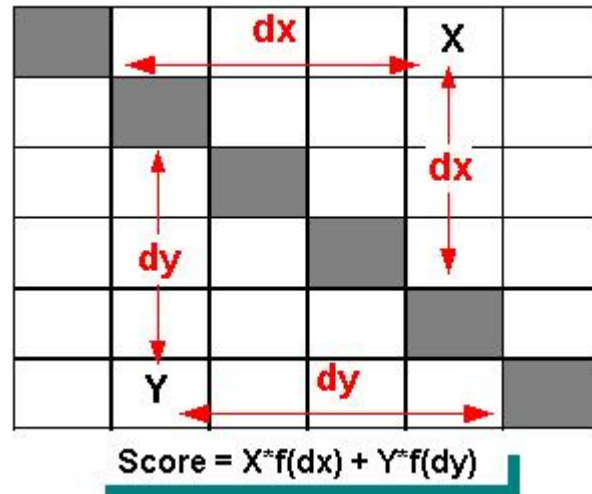

Figure 10. ©CADRAT Scoring Concept (Hitchins 1998).

The distances from each node are multiplied by the strength of association and summed by the row. The sums of all rows are summed to obtain an overall score.

©CADRAT also provides a means to cluster nodes based on an implementation of ISM development work by J. N. Warfield in the 1970s (Hitchins 1998). Several algorithms are provided: manual, first moment, second moment, and automatic clustering. Figure 11 illustrates the effect of each of these clustering algorithms with a representation of the resultant graph (Hitchins 1998). Clustering has come about on the basis of relationships and strengths identified individually by the architect. The tool transforms the data and concisely reveals the structural implications of the initial digraph and incidence matrix. When applied to architecture development, clustering increases node cohesion and decreases coupling that minimizes interchanges a technique to measure the degree of effective modularity.

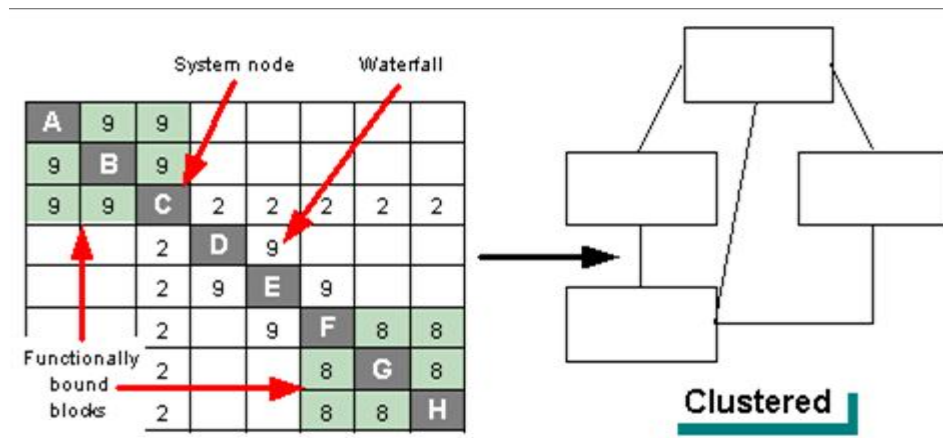

Figure 11. Effect of Cluster Algorithms (Hitchins 1998).

Clustering identifies node groups with the aim of attaining high cohesion and low coupling.

E. DESIGN STRUCTURE MATRIX ANALYSIS

Design Structure Matrix (DSM) analysis is an analytical tool for decomposition and integration with static and time-based DSM types (Stewart 1981). This method provides an objective score of the operational and system stability based upon the results of functional analysis and interface development.

DSM uses a directed adjacency matrix with a counter clockwise direction of association flow. In addition to providing insight of series, parallel, and coupled patterns, this approach visually represents feedback patterns. Illustrated in Figure 12, the feedback is shown in the upper right of the diagonal and feed forward is shown in the lower left of the diagonal.

“Feedback marks correspond to the required inputs that are not available at the time of executing the [function] task. In this case, the execution of the dependent [function] task will be based on assumptions regarding the status of the input [function] tasks” (Yassine 2004).

When there is feedback, the architect manipulates the order to eliminate feedback. If this is not possible, the order is adjusted to position the feedback association as close to the diagonal as possible. As a result, fewer functions are involved in an iteration cycle; which results in a faster system execution process.

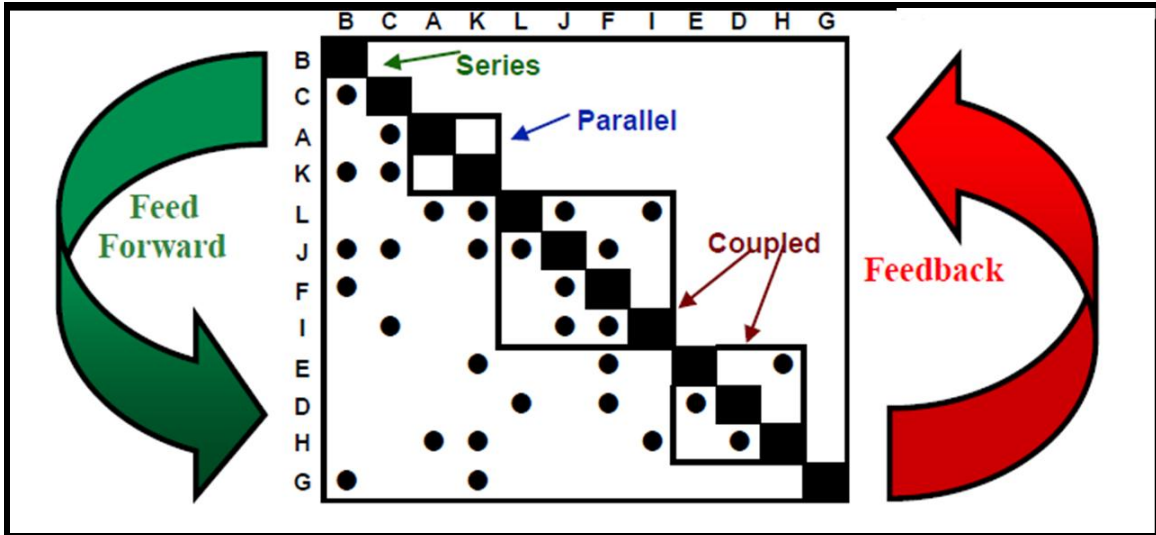

Figure 12. DSM Concept of Representing Feedback (Yassine 2004).

Fundamental design pattern are identified with the DSM. These patterns infer threshold capability of the design under consideration.

Lattix, by Lattix Software©, is one of many industry tools which implements DSM. It has the capability to manually build, view, and cluster components in a hierarchy. The metric of interest calculated by Lattix is system stability. System stability is a value between 0 and 1, where 1 represents maximum stability. It represents a percent of sensitivity to design change, where a lower percent value indicates susceptibility to change and a higher percent value indicates less susceptibility to change. System stability is calculated in Equation (3) where *Average_Impact* is the total number of components that could be affected if a change is made and *Atom_Count* is the total number of components (Lattix Knowledge Database).

$$\text{Stability} = 1 - \left(\frac{\text{Average_Impact}}{\text{Atom_Count}} \right) \quad (3)$$

F. INFORMATION EXCHANGE STANDARD

The information exchange standard defines the information that is passed across the TSN C4I network to participants. It also defines the configuration items, external inputs, and information elements unique to TSN C4I. This standard is fundamental to the development and implementation of TSN C4I in the real world. Development of a

standard is an objective of the study and is a byproduct of the analysis described in this chapter.

G. ARENA PERFORMANCE MODELING

Arena is used to model each sub-alternative analyzed in the organizational AoA which is discussed in the next section. Each sub-alternative is modeled using the operational functions, articulated by the dendritic method, arranged into TSN missions. Within Arena, operational functions correspond to Arena processes and are assigned resource values according to Table 1. These resources are assumed to have equal, legacy or new, capabilities to execute operational functions. A triangle distribution is used to describe the duration of each modeled process where duration is derived from the number of organizational resources demanded by a process. Each model run occurs over one year with resolution in minutes replicated 10 times. The mission duration and resource usage results are extracted using the Arena run report.

Arena is a Discrete Event Simulation (DES) software simulation tool which enables executable models with random generated inputs and processing time distributions. For the purpose of TSN, several operational threads, direct mitigating response, situation awareness, and intelligence, are combined to emulate a generalized mission. The generalized mission is modified by adjusting process attributes to uniquely model each sub-alternative. The direct mitigating response thread is initiated by events that occur based upon an exponential distribution. For example, the transnational threat event is represented by an exponential distribution with an average occurrence of 60 hours. Situation awareness and intelligence threads are continuously running at 0.25 hours and 24 hours, respectively.

Since each arrival event represents real world situation, the Arena entity is assigned a random value as attribute of the entity. The attribute determines how much information is required to complete the response model. The uncertainty is assumed to be normally distributed with a mean of 50 and a standard deviation of 10. When the attribute value is less than 90, transnational threat events, or less than 40, humanitarian aid, and disaster relief/protect environment events, the response model performs intelligence

gathering. The response model exits the intelligence gathering loop one the entity attribute exceeds the threshold.

Each operational thread is a composite of multiple processes that apply triangle distributions to describe time stochastically. Notionally shown in Figure 13, triangle distributions are described by minimum, mode and maximum parameters. Baseline parameter values are established for these functions by this study’s research assuming a single process resource demand. In order to implement each sub-alternative the baseline case is modified on the basis of organizational type and number of assigned resources; a resource is one or more stakeholders identified by the AoA in Table 1. Three modification methods adjust baseline parameter values to achieve a team, group or committee effect.

The team modification type integrates two triangle baseline distributions to reflect one spoke stakeholder and one hub stakeholder processing one function in parallel. The resultant parameter values shifts the minimum and mode values to the right of the original values shown in Figure 14. The distribution does not describe more than two stakeholders, as that is a group or committee model. To achieve integration an ancillary Arena model executes one model thread having concurrent stakeholder branches and each branch has one identical process. From this method a combined stakeholder triangle distribution achieves the effect of the team executing a single operational function

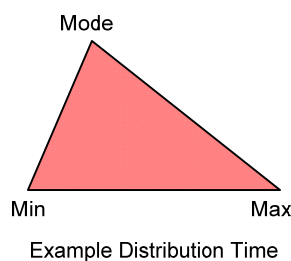

Figure 13. Triangle Distributions Used in Arena Processes.

The Arena model uses the triangle distribution to represent the processing time distributions of the studied organizational structures.

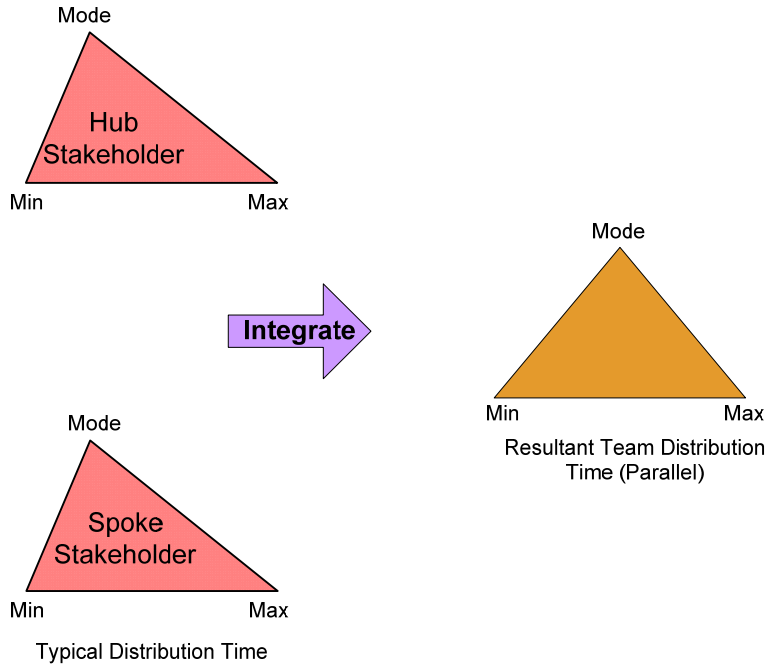

Figure 14. Team Model Triangle Distribution Development.

The Team model triangle distribution is developed from a hub stakeholder and spoke stakeholder pair for each function.

The group modification type integrates three or more triangle baseline distributions to reflect multiple spoke stakeholders processing one function in parallel. The resultant parameter values shifts the minimum and mode values progressively to the right of the original values, shown in Figure 15, with an increase of group numbers. To achieve integration an ancillary Arena model executes one model thread having concurrent stakeholder branches and each branch has one identical process. From this method a combined stakeholder triangle distribution achieves the effect of the group executing a single operational function.

The committee modification type modifies the triangle baseline distributions by dividing minimum, maximum, and mode parameter values by the number of spoke stakeholders in the committee. The effect is a smaller adjusted spoke stakeholder distribution reflecting sub tasking unique to a committee model, as shown in Figure 16. The modification then integrates adjusted spoke stakeholder distributions to reflect multiple spoke stakeholders processing a single function in parallel. In addition the

smaller adjusted spoke stakeholder parameter values are used for the hub stakeholder with an additional percent added. The percent added is equal to the number of spoke stakeholders multiplied by ten percent to account for management overhead associated with the hub stakeholder. The resultant spoke and hub stakeholder distributions are added to form that committee triangle distribution. From this method a combined stakeholder triangle distribution achieves the effect of the committee executing a single operational function.

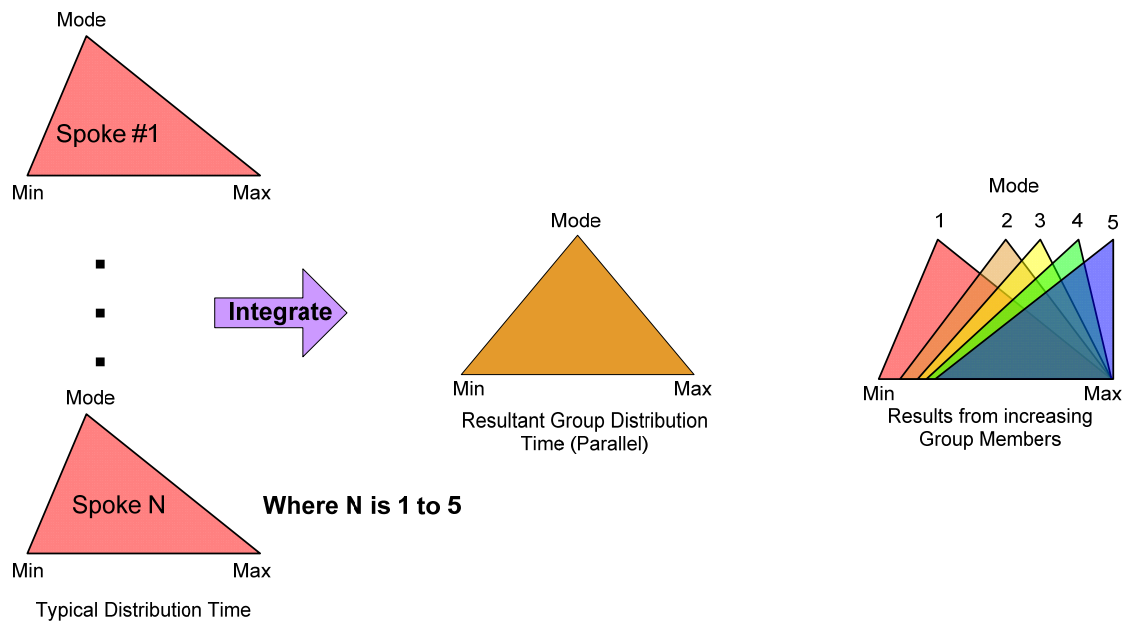

Figure 15. Group Model Triangle Distribution Development.

The group model triangle distribution integrates one to five spoke stakeholders to develop a distribution for each function.

As mentioned, operational functions correspond to Arena processes and are assigned resource values according to Table 1. Each Arena process seizes, delays, and releases one or more resources. The process delay is accounted for by the triangle distributions previously described. Resources are seized and released proportional to their individual functional involvement, described by the sub-alternative in Table 1. The resource capacity is defined as the amount of required resources to prevent balking. The consequence of preventing balking is that TSN responds to all events, not to exceed the direct mitigating response occurrences provided in Chapter IV.

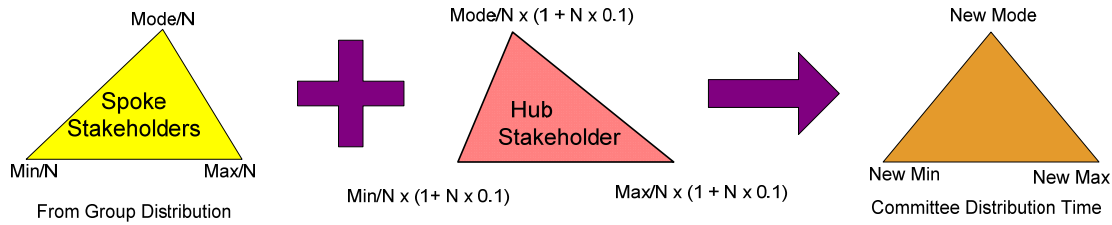

Figure 16. Committee Model Triangle Distribution Development.

The committee model integrates spoke stakeholders and adds the hub stakeholder to develop a distribution for each function.

H. OPERATIONAL ANALYSIS OF ALTERNATIVES

The TSN operational concept presents several considerations worthy of an operational AoA. The TSN C2 stakeholder organizational model is of paramount importance. Given TSN's critical functionality as a C4I system, its fundamental capability is to enable effective collaboration in support of force employment decisions. Furthermore the pursuit of volunteer participation, a core tenet of TSN, involves complex interactions between diverse stakeholders with varying objectives. In order to analyze which organizational model is best suited for the operational concept of TSN, three generalized, multi-stakeholder organizational models are selected from a paper by Marakas (2003). The selected models are analyzed for their effectiveness using a variety of tools described in this chapter. The candidate models are defined as group, team, and committee.

The group organization model, Figure 17, maximizes the interactions among stakeholders. Characteristics of the model include a high degree of communication, increased potential for understanding, and cooperative decision development (Marakas 2003). The combination of these characteristics results in consensus development or buy-in resulting in greater stakeholder engagement. Some disadvantages of the group approach are that it is slower to produce, tends to mediocrity, and is susceptible to technical error given the number of replications and translations of information required to reach every stakeholder. Figure 17 illustrates the group structure as applied to the TSN stakeholder community.

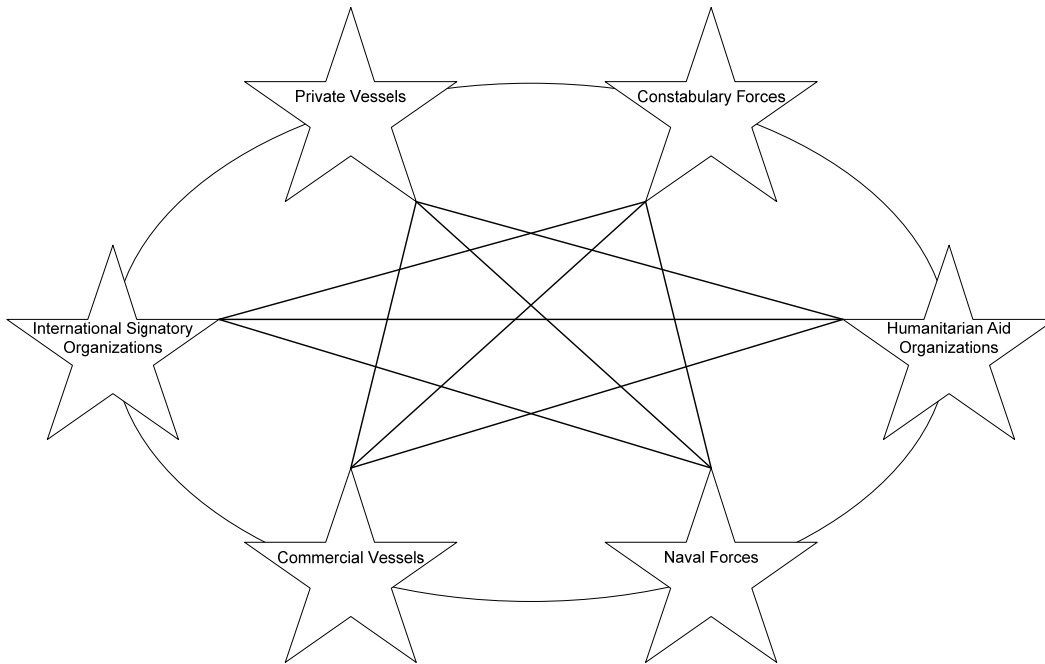

Figure 17. Group Organizational Alternative Structure.

The group organization model maximizes the number of interactions between stakeholders by utilizing a flat topology.

In direct contrast to the group model, the team organizational model minimizes the number of interactions within the stakeholder community. This is done by maintaining one-to-one relationships between spoke stakeholders and a centralized hub stakeholder per function. There are no direct relationships between the spoke stakeholders (Marakas 2003). Resulting from this decrease in relationships the model is able to process tasks faster and is less prone to error than the group model.

Additionally, the team organizational model implements a hierarchy such that the hub stakeholder manages and orchestrates all the spoke stakeholders buffered from all but the hub stakeholder. Trust is a major consideration for TSN and the hub and spoke configuration requires a high degree of trust between the spoke stakeholders and the hub stakeholder. Of the considered structures, this structure has the minimum number of dependencies that need to be implemented. Figure 18 illustrates the team model as applied to the TSN stakeholder community.

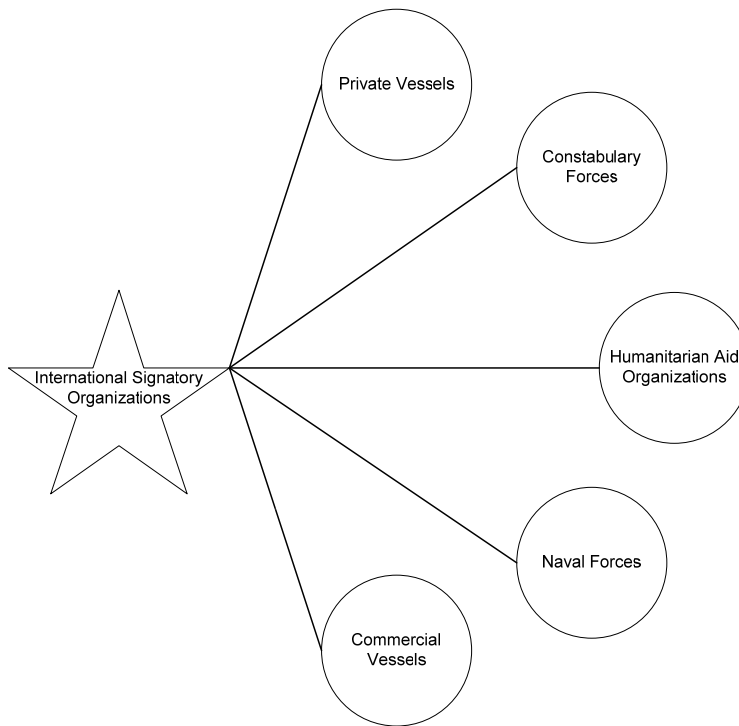

Figure 18. Team Organizational Alternative Structure.

The team organization model minimizes interaction lines by creating a hierarchical hub and spoke topology eliminating lower level relationships.

The committee organization model is a hybrid approach of the two previously discussed organizational models. Like the team model, one hub stakeholder manages and orchestrates the interactions among the spoke stakeholders. However in the committee model the spoke stakeholders are not isolated. By blending the characteristics of the group and team models, the committee approach benefits from a high degree of interaction combined with a sense of hierarchy (Marakas 2003).

Despite these advantages, the committee model is burdened by the need for a trusted hub stakeholder and has the same potential for error as the group model. Moreover given the concentration of interactions, the hub has implicit influence over the other stakeholders. Figure 19 illustrates the committee model applied to the TSN stakeholder community.

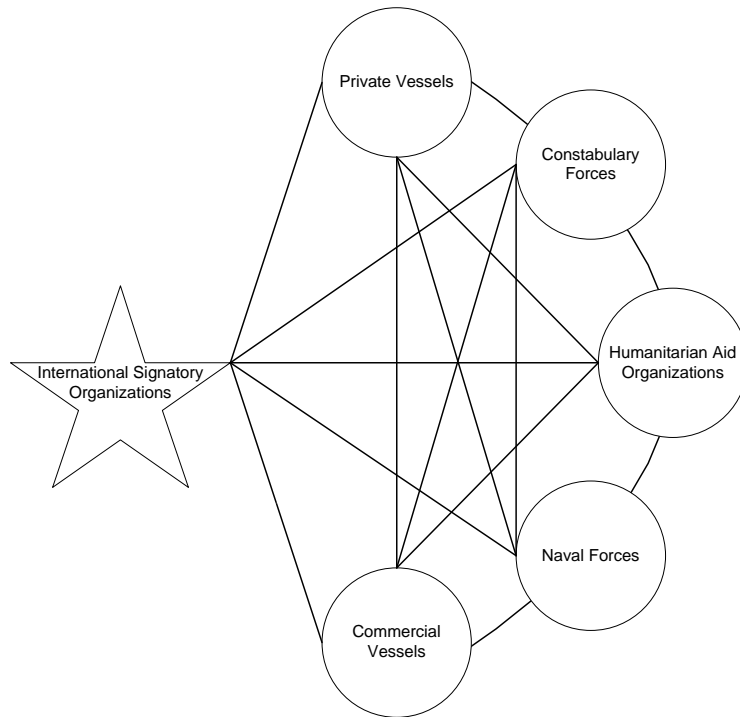

Figure 19. Committee Organizational Alternative Structure.

The committee organization model is a hybrid of the team and group organization models.

In order to realize a multi-layered volunteer force a balance is necessary between stakeholder participation and TSN C4I effectiveness. Table 1 provides a framework to analyze which of the three organization models is preferred for TSN operations. It shows operational functions listed in the far right column and stakeholders listed horizontally across the top. An *L* represents a legacy relationship or responsibility between the function and stakeholder. The extent of the relationship is not quantified in the matrix only that the stakeholder is involved at some level with the function and is using a legacy capability to execute the function. Similarly, an *N* represents a new relationship or responsibility. This indicates the stakeholder is involved, but requires new system capability at some level. Lastly an *O* indicates there is a relationship or capability but it is not active between the stakeholder and C4I function for the specific case in question. The objectives of the matrix are to identify the relationships between the stakeholders and functions, in addition, the matrix identifies new capability required by each stakeholder.

C4I Functions vs. Stakeholders	Constabulary Forces	FBI/Interpol	Boarder Patrol/Customs	Port Police	Coast Guard	Navies	Surface Combatants	Aircraft Carriers	Patrol Combatants	Mobile Logistics	Coastal Defense	Private Vessels	Pleasure	Research	Passenger	Private Fishing	Commercial Shipping Industry	Oil	Food	Raw Materials	Consumer Products	Fishing Industry	Humanitarian Aid Organizations	International Red Cross	World Food Program	Peace Corps	Doctors Without Borders	International Organizations	United Nations	International Maritime Organizations	NATO
	Perform Command and Control																														
Sense Environment																															
Assess Intentions and Capabilities																															
Generate COA's																															
Select Alternatives																															
Plan Details																															
Direct Response																															
Produce Intelligence																															
Task Data Collection																															
Process Data																															
Post Intelligence Products																															
Use Intelligence Products																															
Provide Communications																															
Transmit Information																															
Receive Information																															

Involved Legacy	L	0
Involved New	N	0
Not Involved	O	0

Table 1. TSN Stakeholder Functional Matrix.

The preferred stakeholder organizational model is identified through functional allocation to stakeholders as a function of mission type.

A rating rubric, Table 2, is utilized to organize the qualitative and quantitative evaluation factors for each sub-alternative. The organizational model with the highest aggregate score is identified as the preferred TSN organizational approach. Evaluation factors include: political feasibility, Arena mission duration, Arena resource usage, number of relationships, number of new capabilities items, and use of legacy capability.

Each factor has an assigned weight, shown in Table 3, determined from the study’s assessment of the research documented in Chapter II. From the table seventy percent of the weight distribution is attributed to the quantitative factors yielded by ©Microsoft Excel relationship modeling and Arena mission modeling. The remaining thirty percent of the weight distribution is allocated to political feasibility, a qualitative factor. Difficult to assess, political feasibility factor represents the TSN objective to appeal as an inclusive maritime alliance vice be construed as a closed military coalition highlighting the ambitions of one or a few nations.

Transnational Threat									
Evaluation Factors	Group Alternative	Score	Weight Score	Team Alternative	Score	Weight Score	Committee Alternative	Score	Weight Score
Political Feasibility									
Arena Mission Duration									
Arena Resource Usage									
Number of Relationships									
Number of New Capabilities									
Use of Legacy									
Score									
Humanitarian Aid									
Evaluation Factors	Group Alternative	Score	Weight Score	Team Alternative	Score	Weight Score	Committee Alternative	Score	Weight Score
Political Feasibility									
Arena Resource Duration									
Arena Resource Usage									
Number of Relationships									
Number of New Capabilities									
Use of Legacy									
Score									
Disaster Relief/Protect Environment									
Evaluation Factors	Group Alternative	Score	Weight Score	Team Alternative	Score	Weight Score	Committee Alternative	Score	Weight Score
Political Feasibility									
Arena Resource Duration									
Arena Resource Usage									
Number of Relationships									
Number of New Capabilities									
Use of Legacy									
Score									
Average									

Table 2. AoA Rating Rubric.

The rating rubric measures quantitative and qualitative attributes all nine sub-alternatives. Each sub-alternative is a mission type and organizational model alternative combination.

TSN Score Weighting	
Evaluation Factor	Weight
Political Feasibility	0.3
Arena Resource Duration	0.2
Arena Resource Usage	0.1
Number of Relationships	0.1
Number of New Capabilities	0.1
Use of Legacy	0.2
Sum	1

Table 3. AoA Weight Distribution.

Weight distribution identifies assessment importance and reflects the relative importance given to political feasibility.

This first evaluation factor in Table 3, political feasibility, is a qualitative assignment based on the sub-factors: valued added, sense of fair play, and advocacy, perceived by each stakeholder. These sub-factors are summarized in Table 4. Value added signifies stakeholder perception of TSN’s capability to successfully perform its missions. Sense of fair play signifies stakeholder trust in TSN to protect and account for all interested participants. Advocacy signifies stakeholder willingness to promote TSN in

the international community. Table 4 outlines the sub-factor values assigned based on a low, medium, or high ranking corresponding to values from 1 to 3 respectively.

Political Feasibility			
Dimension ranking	Value	Sum	Score
Low value added, Low sense of fair play, Low advocacy	1,1,1	3	10
Medium value added, Low sense of fair play, Low advocacy	2,1,1	4	20
Medium value added, Medium sense of fair play, Low advocacy	2,2,1	5	40
Medium value added, Medium sense of fair play, Medium advocacy	2,2,2	6	60
High value added, Medium sense of fair play, High advocacy	3,2,3	8	80
High value added, High sense of fair play, High advocacy	3,3,3	9	90

Table 4. Political Feasibility Evaluation Factor Scoring Table.

Political feasibility factor encompasses a range of attributes to consider the international nature of TSN..

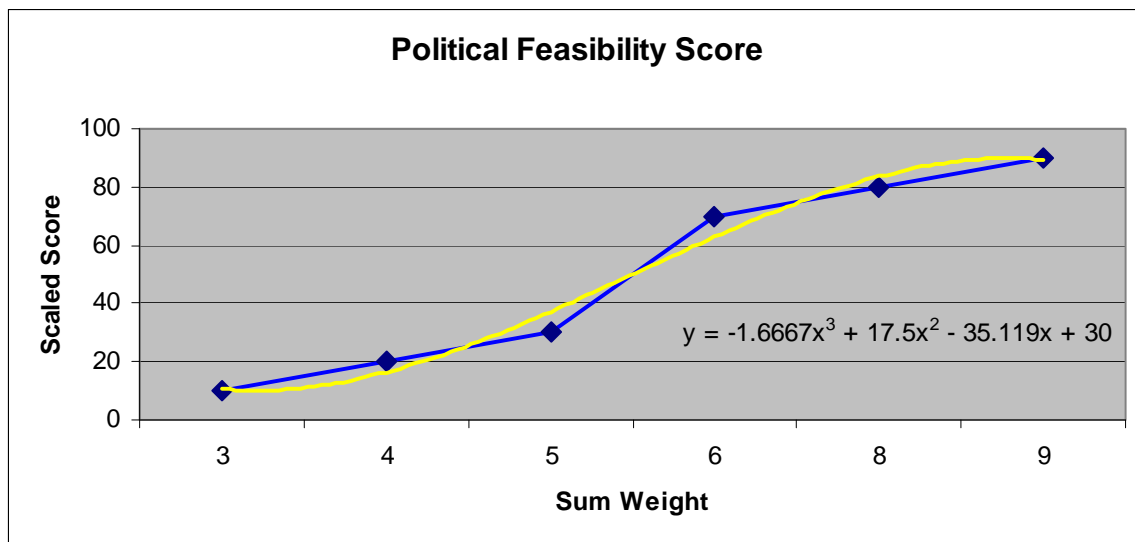

Figure 20. Political Feasibility S-Curve.

The feasibility S- curve represents a reasonable change of values over the low, medium and high indices.

The political feasibility curve, Figure 20, illustrates the range of sub-factor values referenced to an S-curve. The sub-factor values from Table 4, column two, are summed in column three. These values represent the range shown in the abscissa axis of Figure 20. The ordinate axis represents the political feasibility score with a range 10 to 90. The blue connected scatter plot represents the assigned values from the study's assessment. The yellow line represents a third order least square fit regression curve which

approaches an elongated S-curve. This verifies the selection of values and calculation method for political feasibility since its raw shape is consistent with initial accelerating returns and subsequent diminishing returns.

The remaining five evaluation factors are a quantitative analysis of Arena modeling results and Table 1. Described in the next section, the Arena modeling results include the factors of mission duration and resource usage. Number of relationships factor is the individual sum of relationships shown in Figure 17, Figure 18, and Figure 19. New capability factor is the sum total of new capabilities, N , from Table 1 for each sub-alternative. The last factor, use of legacy, is the sum total of legacy capabilities, L , from Table 1 for each sub-alternative. For the values of the first four factors, each are divided by the minimum factor value and expressed as a percent, where preferential consideration is given to minimizing the following: mission duration, resource usage, number of relationships, and number of new capabilities. For the fifth factor, each value is divided by the maximum factor value and expressed as a percent, where preferential consideration is given to maximizing legacy reuse. This effectively normalizes factors values for subsequent application of weights in accordance with Table 3.

I. MISSION SUCCESS

An overarching measure for comparing different operational architectures is the mission success probability, calculated from the likelihood of achieving mission objectives. Equations are developed to provide an algorithmic approach to measure mission success probability. The basis for these equations is tied to the probabilistic values of Measures of Effectiveness (MOE) and Measures of Performance (MOP).

1. Mathematical Basis for Combining Measure of Effectiveness and Measure of Performance

MOEs are defined by “relevancy to mission, importance to mission accomplishment, and risk of not achieving” (Hoivik 2009). The MOEs are selected on the basis of TSN mission necessity. A different set of MOEs are determined for each of the three TSN missions: transnational threat enforcement, humanitarian aid, and disaster relief/protect environment response. Overall mission success is an aggregate of MOEs.

An MOE is a “variable that describes how well a system carries out a task or set of tasks within a given context” (Buede 2000). In practice, each MOE has a probabilistic value of a top level operational function achieving its purpose and is supported by at least one MOP. An MOP is a “variable that describes a specific system property or attribute for a given environment and context” (Buede 2000). Also probabilistic in practice, MOPs are constituent operational functions to top level functions typically described by parallel or series networks.

In a series network, Figure 21, each process is dependent on its predecessor. If one function fails to complete, the entire system comes to a halt. The probability of success for a series network, P , is found through Equation (4) where P_i is each sub-function’s probability of success.

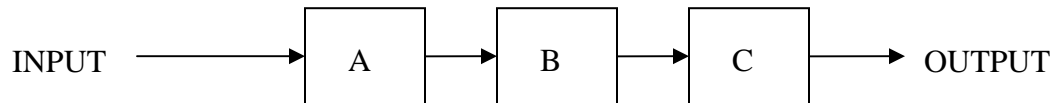

Figure 21. Notional Series Network (Blanchard and Fabrycky 2006).
Each function in a series network cannot be completed until the preceding function is completed.

$$P = \prod_{i=1}^n P_i \quad (4)$$

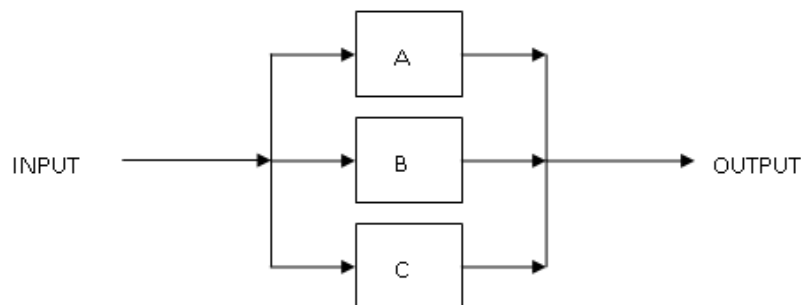

Figure 22. Notional Parallel Network (Blanchard and Fabrycky 2006).
Parallel networks are able to adapt to partial network failure by rerouting to available options.

In contrast, a parallel network can continue to operate by diverting to a parallel process. Figure 22 illustrates a notional parallel network and Equation (5) defines the overall probability of success, P , as a function of the individual probabilities of success, P_i .

$$P = 1 - \prod_{i=1}^n (1 - P_i) \quad (5)$$

2. Excel Decision Tree Modeling

To obtain an estimate of the mission success of TSN the ©Microsoft Excel Decision Tree analysis algorithm is used, Figure 23. The algorithm builds a data mining model by creating a network of splits in a decision tree. The tree is composed of branches that ask, “What is the probability of pass or fail of the given activity?” These decisions are represented as nodes, or splits, in the tree.

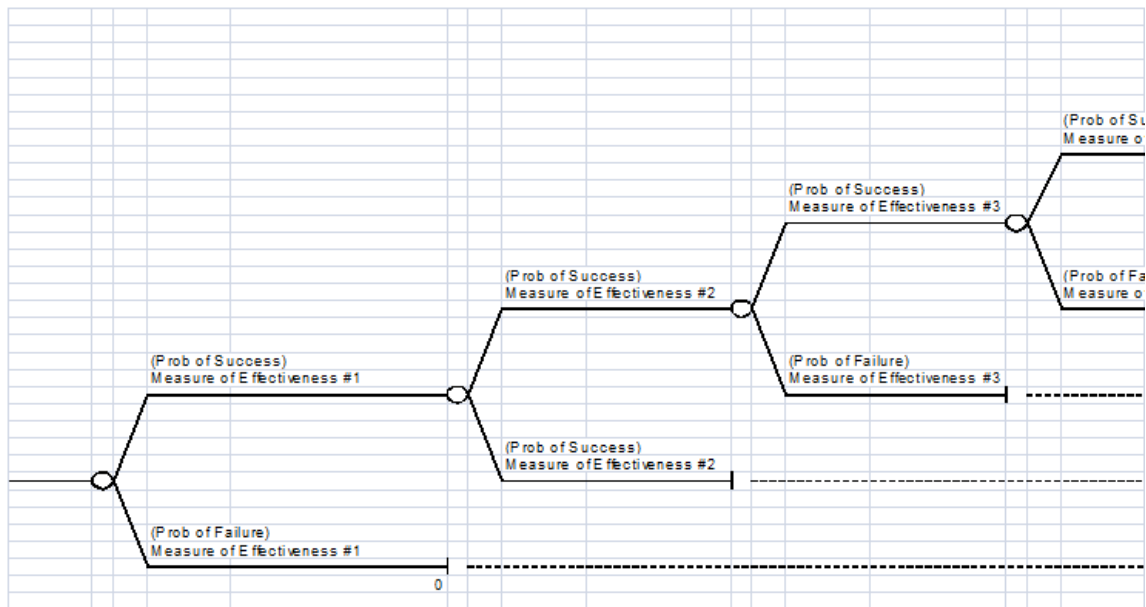

Figure 23. Mission Success Decision Tree.

Overall mission success is determined by analyzing MOEs and MOPs.

The decisions are limited to success or failure of individual functions having MOE's, which are in turn a collection of MOP's. First each MOP's probability of success is calculated. Then, given the network structure of the MOE, either Equation (4) or (5) is

applied to determine the MOE's probability of success. The probability utilized for each MOP is determined by a combination of research and subject area expert recommendations. The probabilities reflect available information and are updated as the study progresses.

©Microsoft Excel Decision Tree takes the cost of a decision into account when selecting the best solution. However, cost is not yet associated with making operational decisions in TSN. To show mission success independent to the cost of each outcome, Equation (4) replaces the predefined algorithm embedded within Excel. This turns the entire decision tree into one overarching series network.

J. DEPARTMENT OF DEFENSE ARCHITECTURE FRAMEWORK MODELS

The development of DoDAF models in CORE® subscribe to version 1.5 as CORE® has not incorporated the current version, DoDAF version 2.0. The DoDAF process follows a six step architecture development process (U.S. Department of Defense 2009).

- Determine Intended Use of Architecture
- Determine Scope of Architecture
- Determine Data Required to Support Architecture Development
- Collect, Organize, Correlate, and Store Architectural Data
- Conduct Analyses in Support of Architecture Objectives
- Document Results in Accordance with Decision-Maker Needs

1. Operational Views

The six step DoDAF architecture development process is compatible with the development of the Operational View (OV) viewpoints. OV-1 is prepared by team analysis of the operational context and its description via a Visio diagram model. OV-2 through OV-7 are prepared using the CORE® schema for DoDAF version 1.5 and its script feature.

2. System Views

The six step DoDAF architecture development process is compatible with the development of the System View (SV) viewpoints. SV-1 through SV-10 are prepared using the CORE® schema for DoDAF version 1.5 and its script feature.

3. Technical Views

The six step DoDAF architecture development process is compatible with the development of the Technical View (TV) viewpoint. TV-1 is prepared using the CORE® schema for DoDAF version 1.5 and its script feature.

K. COST ESTIMATION MODELING

Cost and schedule estimation is a critical step of every systems engineering task. Both must be estimated at the beginning of the task, then tracked and adjusted throughout the system development process to assure that the project is progressing at an appropriate rate. The genesis of these estimates is the Constructive Cost Model (COCOMO) developed as a software project estimation tool by Dr. Barry Boehm in 1981 and updated in 2000, COCOMO II. COCOMO II has been applied across various technical fields, as it generates estimated values of both the early design and post-architecture phases of a program (Madachy 2009). Additionally, it can be customized to model a specific process either the Waterfall process or the University of Southern California (USC) Model-Based Architecting and Software Engineering process (Madachy 2009). For the TSN C4I estimation of development cost, the early design phase of COCOMO II is implemented as this study is involved in the “exploration of alternative software/system architectures and concepts of operation” (Madachy 2009).

COCOMO II generates program cost estimates by first determining the effort in person-months required to complete the task based on the Software Source Lines of Code (S-SLOC). If the S-SLOC size is not known, it can be derived from the specific programming language and system functional points, application points, or use cases. Further tailoring of the effort estimation is done through scaling factors and effort multipliers, as shown in Equation (6) (Madachy 2009).

$$Effort = A \cdot \left(\frac{SLOC}{1000} \right)^B \prod_{i=1}^n EM_i \quad (6)$$

A is a “constant derived from historical data,” set at 2.94 (Madachy 2009). The scale exponent, B , rates the scaling factors: precedence, flexibility, architecture/risk resolution, team cohesion, and process maturity; from very low to extra high. These summed values, SF_i , are combined in Equation (7) and applied to Equation (6) (Madachy 2009).

$$B = 0.91 + .01 \sum_{i=1}^5 SF_i \quad (7)$$

The multiplicative effort multiplier term, EM_i , rates seven cost drivers from very low to extra high. These cost drivers result “in an overall effort adjustment factor to the nominal effort” (Madachy 2009). Knowing the effort allows for the schedule to be calculated using Equation (8).

$$Schedule(months) = C \cdot (Effort)^{[0.28+0.2(B-0.91)]} \cdot \frac{SCED\%}{100} \quad (8)$$

C is another historically derived constant, set at 3.67. Equation (7) is used again for B . $SCED\%$ represents the schedule “compression/expansion percentage” (Madachy 2009). The average software development cost is found in Equation (9). All values estimated by COCOMO II have an 80 percent confidence level.

$$Cost = Staffing \cdot LaborRate \left(\frac{average\$}{month} \right) \quad (9)$$

Building upon COCOMO II is the Constructive Systems Engineering Cost Model (COSYSMO). “Despite the strong coupling between software and systems they remain very different activities in terms of maturity, intellectual advancement, and influences regarding cost” (Valerdi 2006). COSYSMO addresses specific systems engineering variables that are not included into COCOMO II. The COSYSMO effort, Equation (10), is similar to Equation (6).

$$S.E.Effort = A \cdot \left(\sum_k w_{e,k} \phi_{e,k} + w_{n,k} \phi_{n,k} + w_{d,k} \phi_{d,k} \right)^E \prod_{i=1}^{14} CD_i \quad (10)$$

A is a calibration constant set at 0.2536. The middle term is the sum of the easy, nominal, and difficult size driver weights multiplied by the number of each type of size driver. These size drivers are the number of system requirements, interfaces, specific algorithms, and operational scenarios. Both the E exponent, which represents the “diseconomies of scale” factor, and the multiplicative cost driver term, CD_i , parallel the COCOMO II equation. However, the fourteen COSYSMO cost drivers, discussed in Chapter IV, are grouped into only two categories: application and team factors. Most notably, there is no formal COSYSMO schedule equation.

There are several free and commercially available applications that apply these cost model equations. Two were selected to generate estimates for TSN C4I. The Naval Postgraduate School’s web based COSYSMO application is the primary resource for systems engineering cost estimation. This application was developed by NPS professor Dr. Raymond Madachy, who has expert insight into these cost models as he is a co-author of Dr. Boehm’s COCOMO II book and a contributor to Dr. Ricardo Valeridi’s COSYSMO book. Costar™ 7.0 is a software cost estimation tool developed by Softstar Systems that allows for estimation of the early design phase of TSN. The application applies Equations (6) through (9) based on the number of TSN functional points and an arbitrary computer language.

In summary, Chapter III highlighted systems engineering methods employed by this study to develop the TSN C4I operational architecture, system architecture, information exchange standard, and corroborating analysis. The dendritic method allowed the team to articulate operational functions and supporting functions. Use of the AoA, supported by Arena, established an approach to determine which candidate alternative TSN should employ as an organizational structure.

Functional analysis refined operational functions and evaluated system functions to determine structure, process flow, and inputs/outputs of the operational and system domains. ISM and DSM methods use functional analysis results to conduct dependency and functional clustering analysis. On the basis of mission scenarios, the mission success method used MOE’s and MOP’s that determine expectations of achieving TSN C4I

mission goals. The developed system architecture characteristics used by the cost estimation method forecasts software and systems engineering development costs.

In Chapter IV, results are presented on the basis of research findings in Chapter II and the application of systems engineering methods in Chapter III.

IV. RESULTS

Chapter IV is organized into operational domain, system domain and estimated cost sections. Essential figures and tables are included with discussions to support topics, in some discussions supporting details are provided in an appendix.

The operational domain section describes TSN operational characteristics. Results of the AoA and Arena modeling provide TSN organizational insights, which are then incorporated into the TSN concept of operations. Evolving from the concept of operations, an operational node structure along with allocated operational functions and needlines are described using operational scenarios. Mission success is postulated on the basis of operational processes developed from operational functional analysis. The TSN operational architecture is formed by the allocation of operational functions to operational nodes. An allocation assessment, on the basis of operational information dependencies, is conducted. Integration and validation aspects of the TSN operational architecture are provided with an operational test and evaluation plan.

The system domain section describes results of mapping operational functions and information to system functions and data items, respectively. A description of each system function is provided with an allocation to CSCIs based upon a technical pattern. Data items derived from operational information are the basis of the information exchange standard, an objective artifact of this study. Similar to the operational domain, an assessment of the example system architecture, by use of data dependencies, is conducted. From this TSN C4I architecture level, a cost model which represents an early concept development estimate is established.

A. OPERATIONAL DOMAIN

1. Declaration of Operational Functions

The dendritic method develops the cornerstone operational function model, which is the initial point of operational domain analysis. Both provide intelligence and perform

command and control operational functions are needed to achieve the top function provide TSN.

The provide intelligence operational function, shown in Figure 24, is based on the intelligence pattern Task, Process, Post, Use (TPPU) to leverage its alignment with Network Centric Operations' (NCO) new communication service oriented paradigm (Bayne and Paul 2005). An operational capability pattern, TPPU refines the C4I operational capability pattern with specific intelligence process flows and operational functions. The function provides periodic and non-periodic intelligence support to each member of the community of interest, where each member is both an information provider and consumer. By posting intelligence products the authorized users access the information for decision-making; enabling their role in TSN.

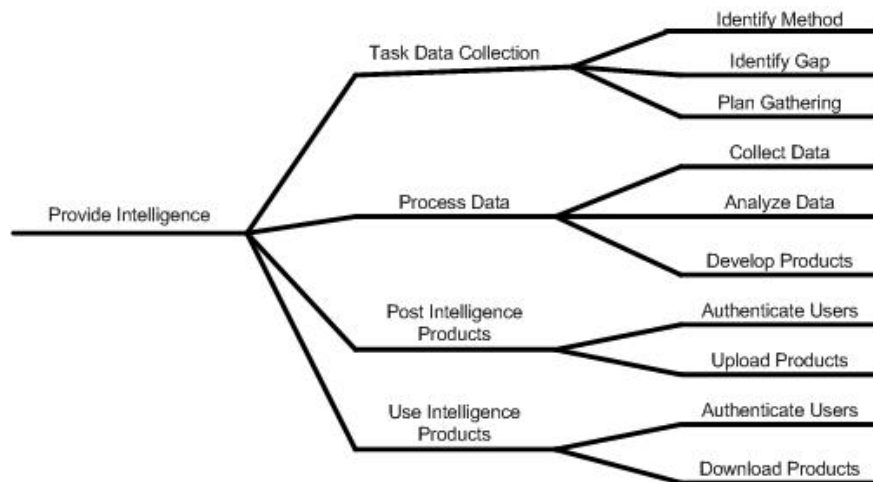

Figure 24. Declaration of Intelligence Operational Functions Using Dendritic Method.

Intelligence operational functions are declared using the dendritic method which is the cornerstone of the operational domain analysis.

The perform command and control operational function, shown in Figure 25, is based upon the Lawson model for C2 (Hwang et al.1982). An operational capability pattern, sense, assess, generate, select, and direct refines the C4I operational capability pattern with specific C2 process flows and operational functions. The environment, characteristics of objects of interest, is sensed for changes in state from an objective state.

An assessment transforms the information from sense into transnational threat intentions and capabilities, humanitarian aid requirements, and disaster or environmental characteristics. Courses of action are generated to mitigate deviations from the objective state determined by international consensus. A preferred alternative is selected with an evaluation of alternatives to international established criteria. The preferred alternative is planned in sufficient detail to direct TSN stakeholders with a coordinated set of tasks.

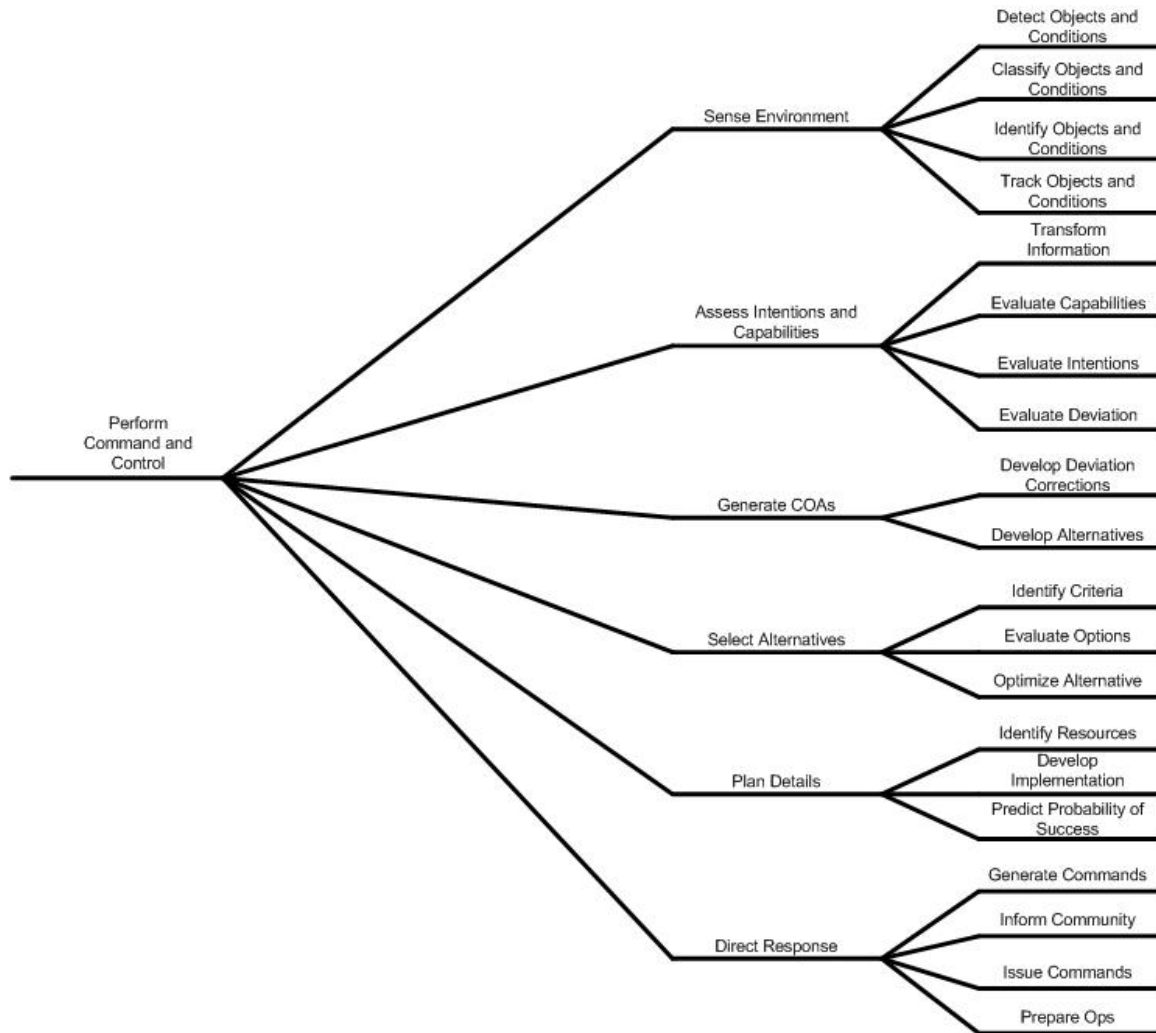

Figure 25. Declaration of C2 Operational Functions Using Dendritic Method.

C2 operational functions are declared using the dendritic method which is the cornerstone of the operational domain analysis.

2. Operational Analysis of Alternatives

As demonstrated in the AoA described below, to optimize TSN operations, the committee model is shown to be the preferred approach. This is based on the evaluation factors: political feasibility, Arena mission duration, Arena resource usage, number of relationships, number of new capabilities, and use of legacy. The organizational model is chosen based on the qualitative and quantitative methodology discussed in Chapter III. This section discusses the outcome of the AoA, beginning with a description of the organizational models' relationship details and ending with a summary of a populated rating rubric, Table 8. Arena analysis data is shown in this rubric in highlighted yellow, and discussed further in a subsequent section.

a. Supporting Arena Modeling Results

In support of the AoA organization analysis, Arena models are created to generate mission processing times and mission resource requirements for each sub-alternative. The operational functions from the dendritic results are grouped into three distinct Arena operational threads: direct mitigating response, situation awareness, and intelligence, as shown in Figure 26, Figure 27, and Figure 28, respectively. For each mission, the three operational threads are run concurrently with resource and processing times as a function of Table 1.

To stimulate each model an Arena generator process is used which produces an entity based upon an exponential distribution. The transnational threat average occurrence is 60 hours and based upon historical data from the PRC, shown in Appendix VII (International Chamber of Commerce, Commercial Crime Services, IMB Live Piracy Map). The high concentration and frequency of attacks off the Somali coast injects a real world stressing case for transnational threats.

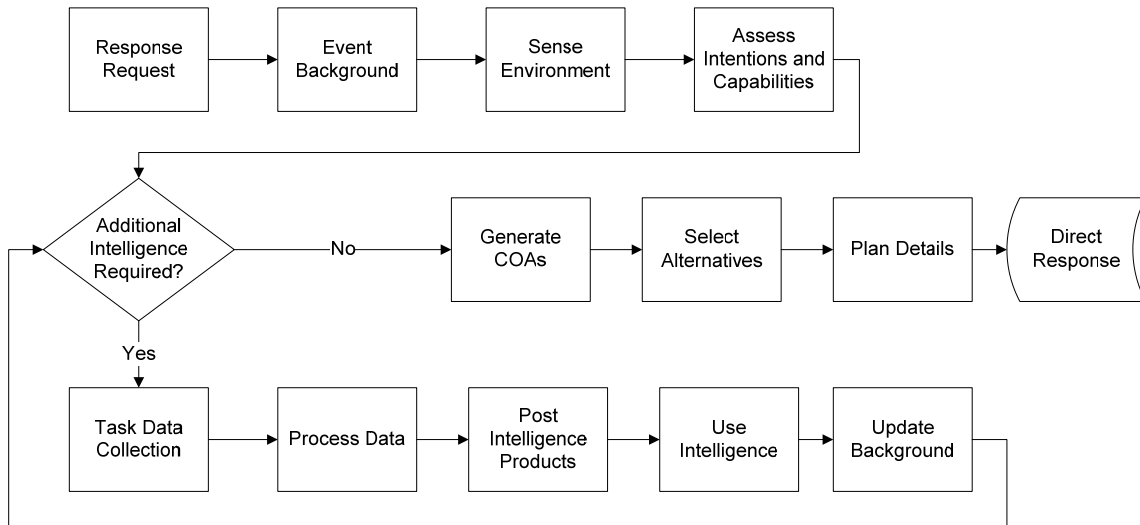

Figure 26. Arena Response Operational Function Model.

The Arena response model instantiates the three TSN missions.

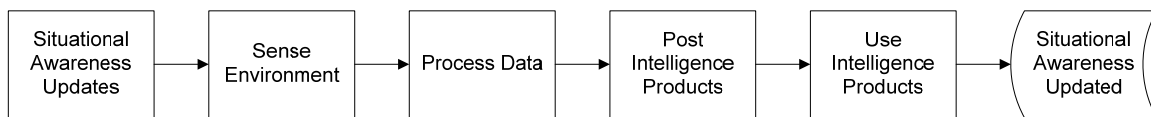

Figure 27 Situation Awareness Operational Function Model.

The Arena situation awareness model implements the development and use of periodic situation awareness for TSN stakeholders.

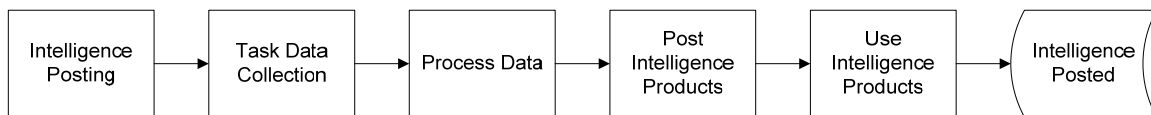

Figure 28. Intelligence Operational Function Model.

The Arena intelligence model implements the development and use of intelligence periodic products for TSN units.

An occurrence for disaster relief is 414 natural disasters requiring humanitarian aid in 2007 (Bear 2008). An average occurrence for oil spills that represent an environment event is calculated from a 5 year (2000 - 2004) average of 18.4 spills per year exceeding seven metric tons (Huijjer 2005). An average occurrence for humanitarian aid is 414 natural disasters and 34 armed conflicts in 2007 (Bear 2008). Each model assumes an exponential distribution parameter, λ , calculated from the reciprocal of

average occurrence consistent with Equation (14) and summarized in Table 5. All events are assumed to be independent.

$$f(x) = \lambda e^{-\lambda x} \quad (14)$$

Event	Mission Model	Average Arrival Time (hours)	Parameter Lamda (λ)
Transnational Threat	Transnational Threat Enforcement	60	0.0167
Disaster Relief	see below	106	0.0094
Protect Environment (oil spills)	see below	2380	0.0004
Combined Disaster Relief/Protect Environment	Disaster Relief/Protect Environment Response	101	0.0099
Humanitarian Aid	Humanitarian Aid	98	0.0102

Table 5. Event Occurrence Times and Parameter Lambda.

Calculated occurrence times are established for each model's generation process.

Response Functions	Delay Type	Minimum	Mode	Maximum	(Units)
Sense Environment	Triangular	10.00	15.00	30.00	Minutes
Assess Intentions and Capabilities	Triangular	1.00	2.00	4.00	Hours
Generate COAs	Triangular	5.00	15.00	30.00	Minutes
Select Alternatives	Triangular	0.75	1.00	1.50	Hours
Plan Details	Triangular	8.00	12.00	24.00	Hours
Direct Response	Triangular	1.00	2.00	3.00	Hours
Intelligence Functions					
Task Data Collections	Triangular	15.00	30.00	60.00	Minutes
Process Data	Triangular	15.00	30.00	60.00	Minutes
Post Intelligence Products	Triangular	5.00	15.00	20.00	Minutes
Use Intelligence Products	Triangular	1.00	2.00	2.50	Minutes
Situational Awareness Functions					
Sense Environment	Triangular	6.00	8.00	10.00	Minutes
Process Data	Triangular	0.33	0.83	1.00	Minutes
Post Intelligence Products	Triangular	0.33	1.00	1.00	Minutes
Use Intelligence Products	Triangular	0.50	0.75	2.00	Minutes

Table 6. Arena Operational Function Baseline Triangle Distributions.

Arena operational functions are based on triangle distribution: minimum, mode, and maximum.

To uniquely model organizational effects, Arena process times are adjusted from the baseline. This approach allows for comparison between the three

organization models to support the AoA. The baseline is established by this study’s assessment. Each operational function is characterized by baseline triangle distributions shown in Table 6. Triangle distributions, with defined minimum, mode, and maximum values, are associated with all Arena process times as a conventional estimate for an unknown processing distribution.

Using instantiated timing distributions, tables located in Appendix VIII, for each model type and process function, simulation run is exercised one year for each model. Data reduction, shown in Table 7, provides data sets, highlighted in green, used by the AoA analysis matrix, Table 8 data highlighted in yellow. Response times are shown as average number of hours to complete a mission. Thus, results are valid to show relative differences among sub-alternatives, the results are not valid to draw absolute conclusions.

	Constabulary Resource Usage (percent)	National Navies Resource Usage (percent)	Private Resource Usage (percent)	Commercial Resource Usage (percent)	Humanitarian Organization Resource Usage (percent)	International Resource Usage (percent)	Average Resource Usage (percent)	Mission Duration Time (hours)
Team Transnational Threat	16.400	29.100	0.000	0.000	3.400	3.000	8.65	26.17
Team Humanitarian Aid	23.500	50.300	0.000	0.000	6.700	4.500	14.17	21.90
Team Disaster Relief / Protect Environment	11.000	18.800	0.000	0.000	3.600	5.600	6.50	22.70
Committee Transnational Threat	8.900	4.600	3.800	4.500	3.900	21.700	7.90	26.32
Committee Humanitarian Aid	6.700	3.500	3.800	4.400	3.900	6.200	4.75	20.84
Committee Disaster Relief / Protect Environment	6.800	3.700	3.800	4.500	4.100	9.000	5.32	21.48
Group Transnational Threat	15.200	15.100	10.900	13.100	1.400	13.100	11.47	27.83
Group Humanitarian Aid	11.300	12.100	10.400	12.400	3.100	10.500	9.97	26.24
Group Disaster Relief / Protect Environment	9.300	9.900	10.100	12.000	1.900	8.600	8.63	26.08

Table 7. Arena Modeling Results Extracted for AoA.

Area modeling results are extracted for the AoA analysis matrix shown in Table 8.

b. Team Model Analysis Results

The team model's number of relationships between stakeholders, R , is assessed with Equation (11); where N is the number of stakeholders.

$$R = (N - 1) = (6 - 1) = 5 \quad (11)$$

The team hub stakeholder in this model is best satisfied by the international signatory organizations. Currently international signatories have a legacy set of resources that service the mission of coordination and execution of multi-national partnerships; which TSN endeavors to accomplish. An advantage of the team model is its scalability of relationships. With each additional stakeholder, there is only one additional relationship. This linear property is unique to the team model.

Operationally this model promotes a centralized approach to manage TSN. As threat events occur, awareness, information, and other information data sets pass through the team hub stakeholder for decision making. Therefore, the ultimate responsibility lies with the international signatories. This requires a bureaucracy to support administration of the TSN operations. Despite being a familiar organizational model for naval and constabulary forces, it is not widely accepted nor practiced in commercial and international settings. However, the model effectively leverages spoke stakeholder capabilities. A consequence of this model requires new capability for international signatories, since they have the greatest number of relationships to manage.

c. Group Model Analysis Results

Stakeholders assume a position of equality within a group model yielding a flat organization, no hierarchical structure. Utilizing the Equation (12) generates the number of relationships between stakeholders.

$$R = \frac{N(N-1)}{2} = \frac{6(6-1)}{2} = 15 \quad (12)$$

From Equation (13) fifteen relationships are managed. By contrast to the team model, which grows linearly, the group model grows as a power of N , refer to

Equation (13). The number of relationships, R , is a function of the number of stakeholders, N , raised to the power of approximately 1.8.

$$R = 0.8598 * (N - 1)^{1.8143} \quad (13)$$

From an operational perspective the group model implies several items of notice. First, because TSN has two major functions; perform command and control, and provide intelligence, each stakeholder is required to have a full capability to accomplish these functions. This alternative requires each stakeholder to perform both functions to equivalent capability. Universal tasking generates considerable information exchanges due to the high number of relationships of the group model. As a consequence, solution techniques are needed to manage the high information exchange, such as fusion, database replication, etc. Many of the TSN stakeholders do not currently have a complete functional set native to their systems. This lack of legacy capability requires new TSN capability of potential stakeholders to effectively engage in TSN operations. A benefit of the group approach, it maximizes intelligence information and C2 participation, thus building a stakeholder consensus.

d. Committee Model Analysis Results

The committee organizational model is a hybrid of the group and team models where each spoke stakeholder has a direct relationship to the hub stakeholder, in addition to relationships between each other. The number of relationships is also fifteen, identical to the group model. There is an implied hierarchy where all spoke stakeholders are managed by the hub stakeholder, international signatories. The international signatories de-conflict tasking to limit duplication of efforts while optimizing resources available to the committee. Additionally, the international signatories ensure that each committee spoke stakeholder accomplishes their tasking in a constructive manner.

As shown below, the committee model is the preferred TSN approach based on collective evaluation factors and analysis ranging from political feasibility to relationship complexity.

e. TSN Rating Rubric Analysis

The committee model is the preferred organizational model, indicated in Table 8, with the average score of 11.16.

Evaluation Factors	Group Alternative Value	Score	Weight Score	Team Alternative Value	Score	Weight Score	Committee Alternative Value	Score	Weight Score
Political Feasibility	60.00	60.00	18.00	20.00	20.00	6.00	60.00	60.00	18.00
Arena Mission Duration	27.83	74.88	14.98	25.84	80.65	16.13	26.32	79.18	15.84
Arena Resource Usage	11.47	41.33	4.13	9.70	48.88	4.89	7.91	59.96	6.00
Number of Relationships	15.00	33.33	3.33	5.00	100.00	10.00	15.00	33.33	3.33
Number of New Capabilities	50.00	2.00	0.20	1.00	100.00	10.00	27.00	3.70	0.37
Use of Legacy	154.00	96.86	19.37	75.00	47.17	9.43	110.00	69.18	13.84
Score	10.00			9.41			9.56		
Humanitarian Aid									
Evaluation Factors	Group Alternative Value	Score	Weight Score	Team Alternative Value	Score	Weight Score	Committee Alternative Value	Score	Weight Score
Political Feasibility	80.00	80.00	24.00	40.00	40.00	12.00	80.00	80.00	24.00
Arena Resource Duration	26.24	79.42	15.88	25.94	80.34	16.07	20.84	100.00	20.00
Arena Resource Usage	9.95	47.67	4.77	8.24	57.52	5.75	4.74	100.00	10.00
Number of Relationships	15.00	33.33	3.33	5.00	100.00	10.00	15.00	33.33	3.33
Number of New Capabilities	55.00	1.82	0.18	20.00	5.00	0.50	40.00	2.50	0.25
Use of Legacy	159.00	100.00	20.00	53.00	33.33	6.67	110.00	69.18	13.84
Score	11.36			8.50			11.90		
Disaster Relief/Protect Environment									
Evaluation Factors	Group Alternative Value	Score	Weight Score	Team Alternative Value	Score	Weight Score	Committee Alternative Value	Score	Weight Score
Political Feasibility	80.00	80.00	24.00	60.00	40.00	12.00	90.00	90.00	27.00
Arena Resource Duration	26.08	79.91	15.98	25.95	80.31	16.06	21.48	97.02	19.40
Arena Resource Usage	8.65	54.85	5.48	7.23	65.58	6.56	5.30	89.47	8.95
Number of Relationships	15.00	33.33	3.33	5.00	100.00	10.00	15.00	33.33	3.33
Number of New Capabilities	55.00	1.82	0.18	24.00	4.17	0.42	40.00	2.50	0.25
Use of Legacy	150.00	94.34	18.87	44.00	27.67	5.53	104.00	65.41	13.08
Sub-Total	11.31			8.43			12.00		
Average	10.89			8.78			11.16		

Table 8. Organization Model AoA Rating Rubric.

The scoring matrix presents each sub-alternative score and an average total for the group, team, and committee organizational model.

In the Table 8 the organizational model value is converted to a score by means of dividing either a maxima or minima of the value set for the same evaluation factor of all sub-alternatives by the value. The use of a maximum or minimum is chosen to achieve a preferential score. For example, for the Group alternative the Arena Mission Duration factor divides 20.84, minima, by 27.83, times 100 to obtain 74.88. Minima are used by Arena Resource Usage, Number of Relationships, Number of New Capabilities evaluation factors to obtain the score. Use of Legacy evaluation factor uses the maximum. The weights used in the analysis are from Table 3.

Although the committee model does not score as highest for mitigating a transnational threat mission, it did score significantly higher for the other mission types. The team model scored the lowest over all; due the inefficiencies in resource management. Furthermore, the team model scores low in political feasibility as it promotes a “go-it-alone” approach to TSN missions. The group model scored a close second overall due to its slower and less efficient performance of the humanitarian aid mission. Interestingly, the group model attains the maximum score for the transnational threat mission due to its use of legacy capabilities.

The highest single score, 12.00 in Table 8, of the nine sub-alternatives is the committee organizational model performing the disaster relief/protect environment mission. The prime factors contributing to this result are its political feasibility rating and Arena factors. These are consistent with Chapter I and Chapter II findings; that the international community needs synergy among nations for disaster response and environmental governance.

f. Operational Force Mix and Mission Duration Consequence

The preferred approach, committee, offers the best resource efficiency across all TSN missions. By contrast to the other sub-alternatives, committee stakeholders employ more of their capabilities to accomplish the missions. This effect supports the TSN objective to promote widespread stakeholder involvement.

g. AoA Sensitivity Analysis

The analysis reported in Table 8 assumes weighting distribution according to Table 2 of Chapter III. It is also assumed equal weighting for the three missions: transnational threat enforcement, humanitarian aid, and disaster relief/protect environment response. An evaluation of these weightings provides insight to results sensitivity. As discussed in Chapter III the largest weighting factor is assigned to political feasibility since it is a principal consideration of TSN. With an equal weighting distribution analysis ranking does not shift maintaining the committee model being preferred. Within the range of sensitivity evaluated, the team model failed to achieve a score greater than either committee or group. To address all missions since they are

equally weighted, the committee model is selected as the preferred organizational structure for TSN.

3. Concept of Operations

The concept of operations for the TSN C4I, depicted in Figure 29, is synthesized from the community organizational model, TSN mission types, and operational functions from the dendritic model.

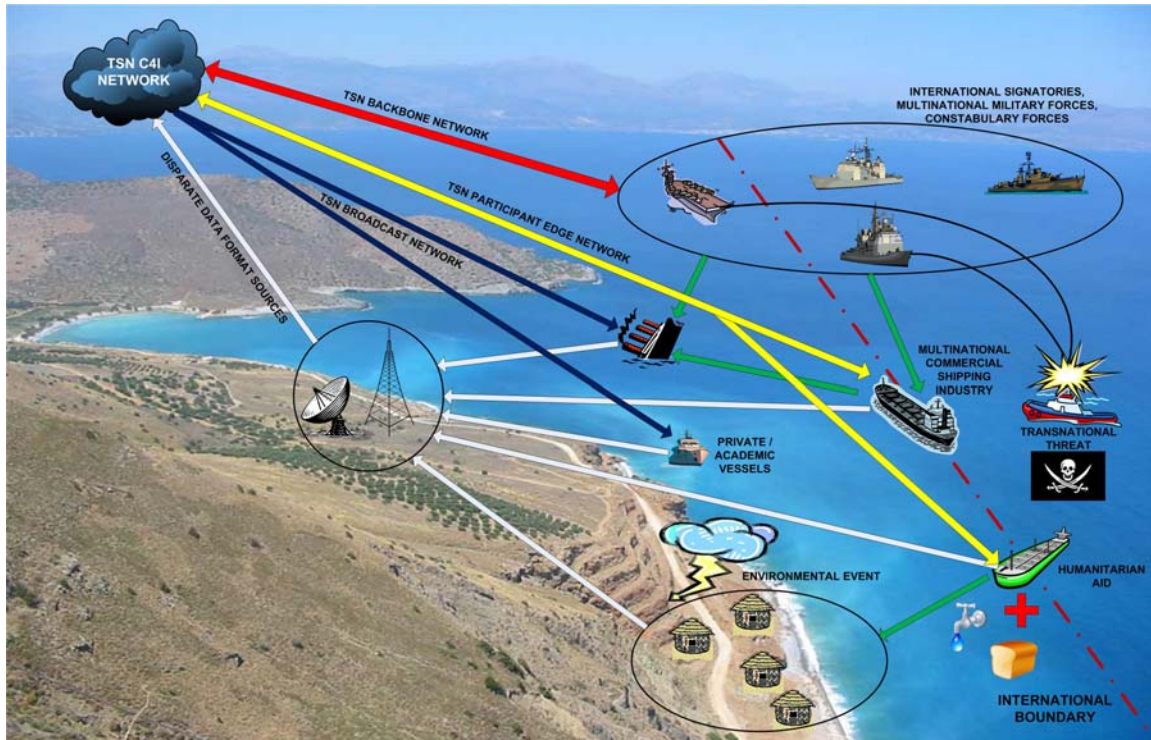

Figure 29. TSN Operational View.

The TSN C4I system is comprised of a backbone, edge, and broadcast capability which join TSN stakeholders.

The TSN C4I gathers and fuses information, shown as white unidirectional arrows, from all participants within the operational area and promulgates the information across the TSN C4I system to participants based on their individual access level. This allows the appropriate stakeholders, grouped by black lines, to perform mitigating actions, shown as green unidirectional arrows, in response to trigger events, depicted as transnational threats, humanitarian aid, and disaster relief/protect environment response. The overarching TSN C4I system, shown as the cloud in the top left corner, is a

combination of three distinct capabilities: TSN C4I backbone, shown as the red bidirectional arrow, TSN C4I participant edge, shown as the yellow bidirectional arrows, and TSN C4I broadcast, shown as the blue unidirectional arrows.

The TSN C4I backbone capability is the highest trusted level of the TSN C4I system and is reserved for international signatory organizations, naval forces, and constabulary forces. This capability is primarily tasked to push and pull information that is too sensitive to be passed indiscriminately, such as, but not limited to, the location and quantity of naval units, specific commercial shipping lanes, unsubstantiated sensor information, and other naval and constabulary intelligence. Furthermore, the TSN C4I backbone capability has unrestricted access to all information pushed from the lower levels of the overarching TSN C4I system.

The TSN C4I edge capability is reserved for the commercial shipping industry and humanitarian aid organizations. This system provides these stakeholders the ability to push trusted situation awareness information to the overarching TSN C4I system, while allowing limited pulling from the TSN C4I backbone capability. This limited pulling of information allows for sensor and other relevant intelligence information to be passed to these stakeholders without divulging the source of the information. The ability to access this intelligence information is critical for first responders to disaster relief/protect environment events and to mitigate transnational threats. Moreover, the TSN edge capability has unrestricted access to information pushed by the TSN C4I broadcast capability.

The lowest trusted level of the TSN C4I system, the TSN C4I broadcast capability, is reserved for private vessels. These vessels push information to the overarching system, such as AIS and LRIT information types, but are only able to pull a limited portion of TSN C4I information. This information is limited to local transnational threat alerts and the location of other private vessels in the operational area. However, the private stakeholder can be tasked to provide first response capabilities to disaster relief/protect environment events. If they accept, they are then given the ability to push

additional situation awareness information, and pull from a limited version of the TSN C4I edge capability.

The TSN operational concept differs from SSTR operations as described by the Military Support to Stabilization, Security, Transition, and Reconstruction Operations Joint Operating Concept (JOC). The central idea of SSTR operations is:

“... U.S. policy carried out by U.S. military forces, civilian government agencies, and, in many cases multinational partners, will on helping a severely stressed government avoid failure or recover from a devastating natural disaster, or on assisting an emerging host nation government in building a ‘new domestic order’ following internal collapse or defeat in war” (U.S. Joint Forces Command 2006).

By contrast the TSN concept of operations carries out the consensus of the international community with naval and constabulary forces interacting with commercial and humanitarian aid organization stakeholders. The TSN concept includes similar missions stated in the JOC including delivery of humanitarian assistance, reconstruction of critical services, restoration of essential services, and establishment of rule of law (U.S. Joint Forces Command 2006). These missions are implemented supporting international guidance with volunteer forces and intelligence resources. The framework of the TSN C4I architecture, described in the remaining sections of the thesis, differs from the JOC vision which framework is centered upon U.S. military systems.

4. Operational Functions, Nodes, and Needlines

Level one and level two operational functions of TSN, shown in Figure 30, mirror the functional analysis results of the dendritic approach. They are arranged in an intuitive order from left to right culminating in full TSN operational functionality.

The Provide TSN operational function, level one, implements an operational pattern which encompasses: standard practices, relevant capabilities, and interoperability requirements. The provide intelligence operational function, level two, provides intelligence product collection, information level fusion and intelligence products, that is, an intelligence summary, an operational picture for situation awareness, and discrete intelligence reports on vessels and persons. The perform command and control

operational function, level two, provides an interaction point with international authorities, management of TSN units, and development of coordinated TSN unit actions with stakeholders. The operate unit operational function, level two, provides sufficient interaction and unit level functionality to interoperate with TSN nodes.

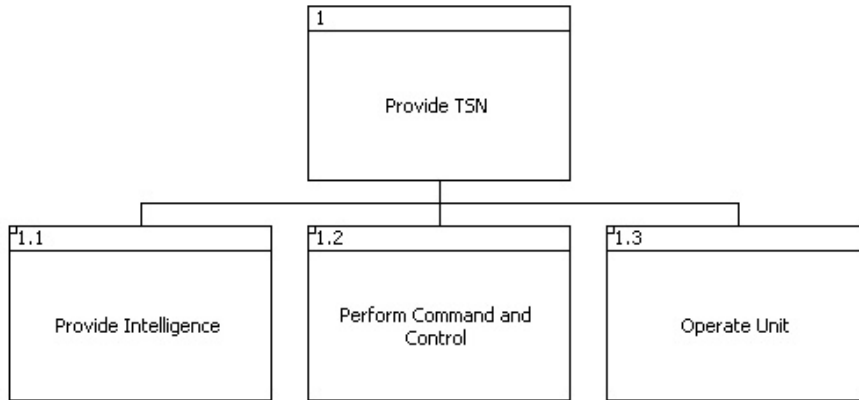

Figure 30. TSN Operational Function Hierarchy.

TSN top level operational functions provide complete operational functionality.

a. Provide Intelligence Operational Function

The provide intelligence operational function is composed of Task Data Collection, Process Data, Post Intelligence Products, and Use Intelligence Products, (TPPU) as shown in Figure 31.



Figure 31. Provide Intelligence Operational Function FFBD.

The TSN Provide Intelligence operational function collects and disseminates TSN relevant intelligence products.

Provide intelligence obtains information of intelligence value from external sources and TSN units. External sources request specific military and law enforcement information on an as-needed basis to support TSN enforcement and assessment of vessels and persons of interest. Combined with TSN unit information and

open source information, intelligence processing develops products for broad distribution as well as products for specific operations. With protection mechanism in place the products are posted for use by authorized users.

Task, Process, Exploit, and Disseminate (TPED) preceded TPPU which is the current NCO operational capability with emphasis on net centrality. Where TPED used centralized control of all activity, TPPU uses decentralized control and uncoordinated independent activities (Funk and Sorensen 2005). With TPPU the intelligence process posts products from which the user may obtain; whereas, with TPED dissemination to the user was integral to the intelligence process. The decoupled dependency between user and intelligence provider aligns with current architecture approaches of publish and subscribe style, or service oriented architecture style.

b. Provide Command and Control Operational Function

The provide command and control operational function is composed of sense environment, assess intentions and capabilities, generate COAs, select alternatives, plan details, and direct response, Figure 32.

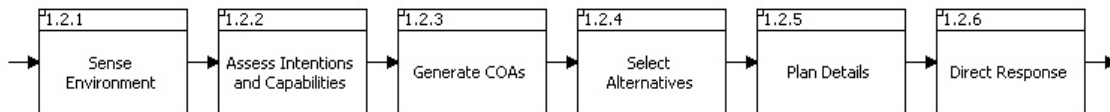

Figure 32. TSN Provide Command and Control Operational Function FFBD.
The TSN Command and Control operational function manages the TSN Unit and determines direction consistent with international signatories’ policies.

The primary objective of the provide command and control operational function is to influence the environment by means of the TSN units. The function must sense the tactical environment by collecting, analyzing and forecasting TSN force assets and external entities which are operating in a common physical environment. The information is transformed to assess the intentions and capabilities of friendly, hostile and neutral assets. By the comparison of international policy to the situation, the function generates deviations and a plan, Course of Action (COA), to return to a desired state. The COAs are analyzed in terms of international criteria that result in a preferred plan. The

plan is expanded with sufficient details to make actionable TSN unit tasks which are promulgated to appropriate assets for implementation.

c. Operate Unit Operational Function

The operate unit operational function is composed of provide unit mission information, inform land node, inform TSN node, perform unit action, provide unit sensed contacts, coordinate unit operations, process unit information, release image, and release contact report, Figure 33.

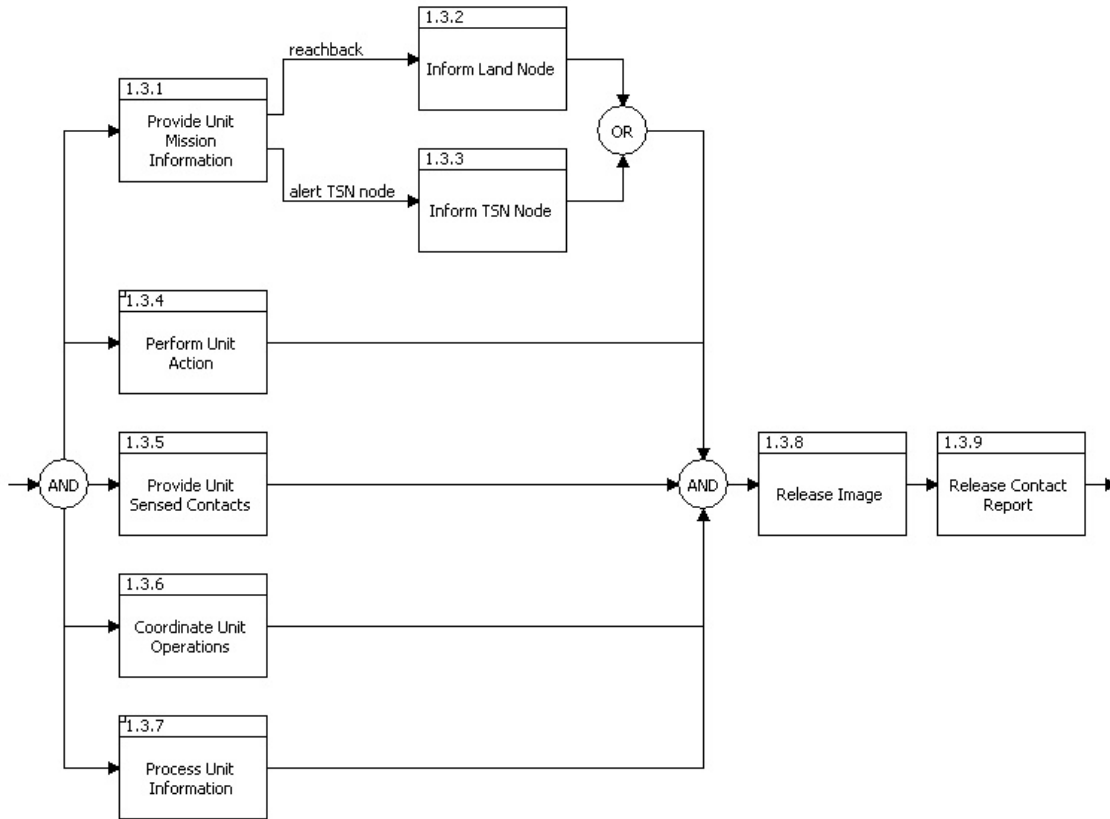

Figure 33. TSN Operate Unit Operational Function FFBD.

The TSN Operate Unit operational function represents those functions on TSN unit necessary of participation in TSN.

The operate unit operational function is distributed among TSN units comprised of navy, constabulary, humanitarian, commercial, and private units. For compatible operations between TSN and legacy systems, the units provide relevant vessel

and mission information to land nodes, command and control node, and other TSN units. Coordinated enforcement operations are supported with unit action synchronization which relies on the common ability to process TSN specific unit information.

d. Operational Nodes

Operational nodes are conceptual entities which include computers, communication and related capability. As shown in Figure 34, TSN is built from three principal operational nodes: command and control node, intelligence node and unit node. The latter node includes the following instances: constabulary node, humanitarian node, commercial node, private node and navy node. In total these nodes provide a structure on which the operational functions are projected as shown in Table 9. These projected operational functions include all functions and addition lower level operational functions articulated in the dendritic approach.

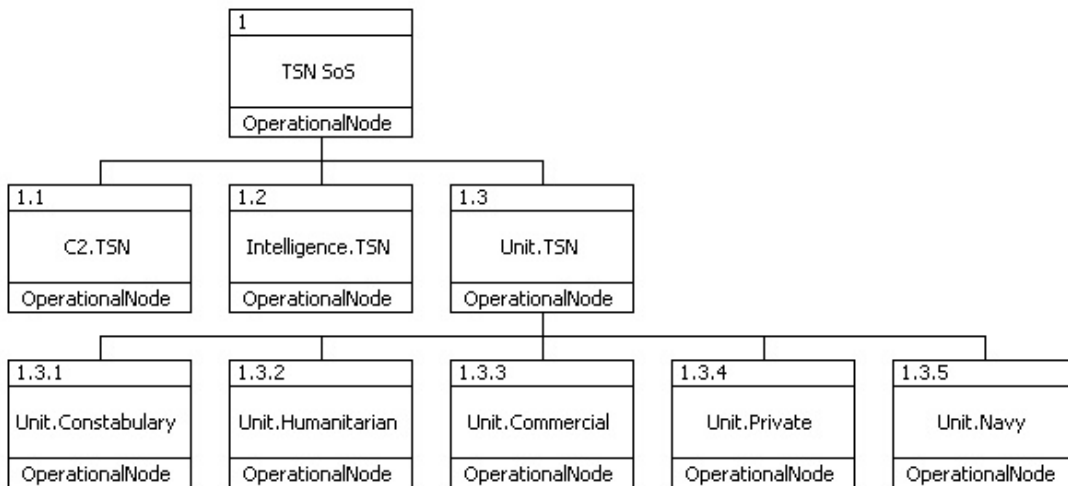

Figure 34. TSN Operational Nodes Hierarchy.

The TSN node is composed of 3 principal nodes and the Unit node is composed of 5 constituent nodes.

Node	Assigned Operational Activities	
Command and Control (C2).TSN	Collect Law Enforcement Rpt Collect Fingerprints Collect Contact Report Collect Imagery Perform Command and Control Sense Environment Receive Humanitarian Request Detect Objects and Conditions Classify Objects and Conditions Identify Objects and Conditions Track Objects and Conditions Analyze ISR Assess Intentions and Capabilities Transform Information Evaluate Capabilities Evaluate Intentions Evaluate Deviation Generate COAs Develop Deviation Corrections Develop Alternatives Select Alternatives Identify Criteria Evaluate Policy Evaluate Objectives	Apply ROE Evaluate Options Optimize Information Act Alternative Optimize Reposition Act Alternative Optimize Protective Act Alternative Optimize VBSS Act Alternative Optimize Armed Act Alternative Plan Details Identify Resources Develop Implementation Get More Information Plan Reposition Act Plan Protective Act Plan VBSS Act Plan Weapons Act Predict Probability of Success Direct Response Generate Commands Inform Community Release Environment Event Issue Commands Prepare Operations Release Unit Vessel Incident Request Operational Picture

Node	Assigned Operational Activities	
Intelligence.TSN	Provide Intelligence Task Data Collection Identify Gap Identify Method Plan Gathering Release Intelligence Tasking Process Data Collect Data Collect Sensed Track Files Collect External Data Sources Collect External Situational Information Collect AIS Summary Collect LRIT Summary Collect PRC Summary Collect Search and Rescue Collect Security Alert Collect Environmental Summary Collect External Intelligence Information Collect Law Enforcement Rpt Collect Photo Collect Fingerprints Collect Contact Report	Collect Imagery Analyze Data Analyze Common Picture Data Analyze Sensed Track Files Analyze AIS Summary Analyze LRIT Summary Analyze PRC Summary Analyze Search and Rescue Analyze Security Alert Analyze Enviromental Summary Analyze Intelligence Summary Data Analyze Unit Incident Person Msg Analyze Unit Intelligence Message Analyze Unit Incident Vessel Msg Develop Products Develop Operational Picture Develop Intelligence Summary Post Intelligence Products Authenticate Users Upload Operational Picture Upload Intelligence Products Release Intelligence Summary Release Operational Picture Use Intelligence Products Authenticate User Requests Download Products Download Intelligence Summary Download Operational Picture
Unit.Constabulary Unit.Humanitarian Unit.Commercial Unit.Private Unit.Navy	Provide Unit Mission Information Inform Land Node Inform TSN Node Perform Unit Action Perform Unit Coordination Perform Unit Intelligence Action Provide Unit Sensed Contacts Coordinate Unit Operations Process Unit Information Release Intelligence Message	Receive Intelligence Summary Process COA Process Unit Operational Picture Receive Unit Intelligence Tasking Request Intelligence Summary Release Unit Person Incident Release Unit Vessel Incident Process Intelligence Tasking Release Image Release Contact Report

Table 9. Operational Node and Operational Function Mapping.

TSN operational nodes are mapped to operational functions.

e. TSN Needlines

TSN needlines represent information interaction, shown in Figure 35, among TSN unit nodes, command and control node, intelligence node, and external entities. Based upon analysis of the operational functions for each node, needlines are identified to carry operational information as either input to or output from an operational

function. The assignment of operational functions to operational nodes and their needlines is provided in Table 10.

In Appendix VIII, DoDAF OV-3 and OV-7 describe the assignment of operational information to needlines and the operational information hierarchy.

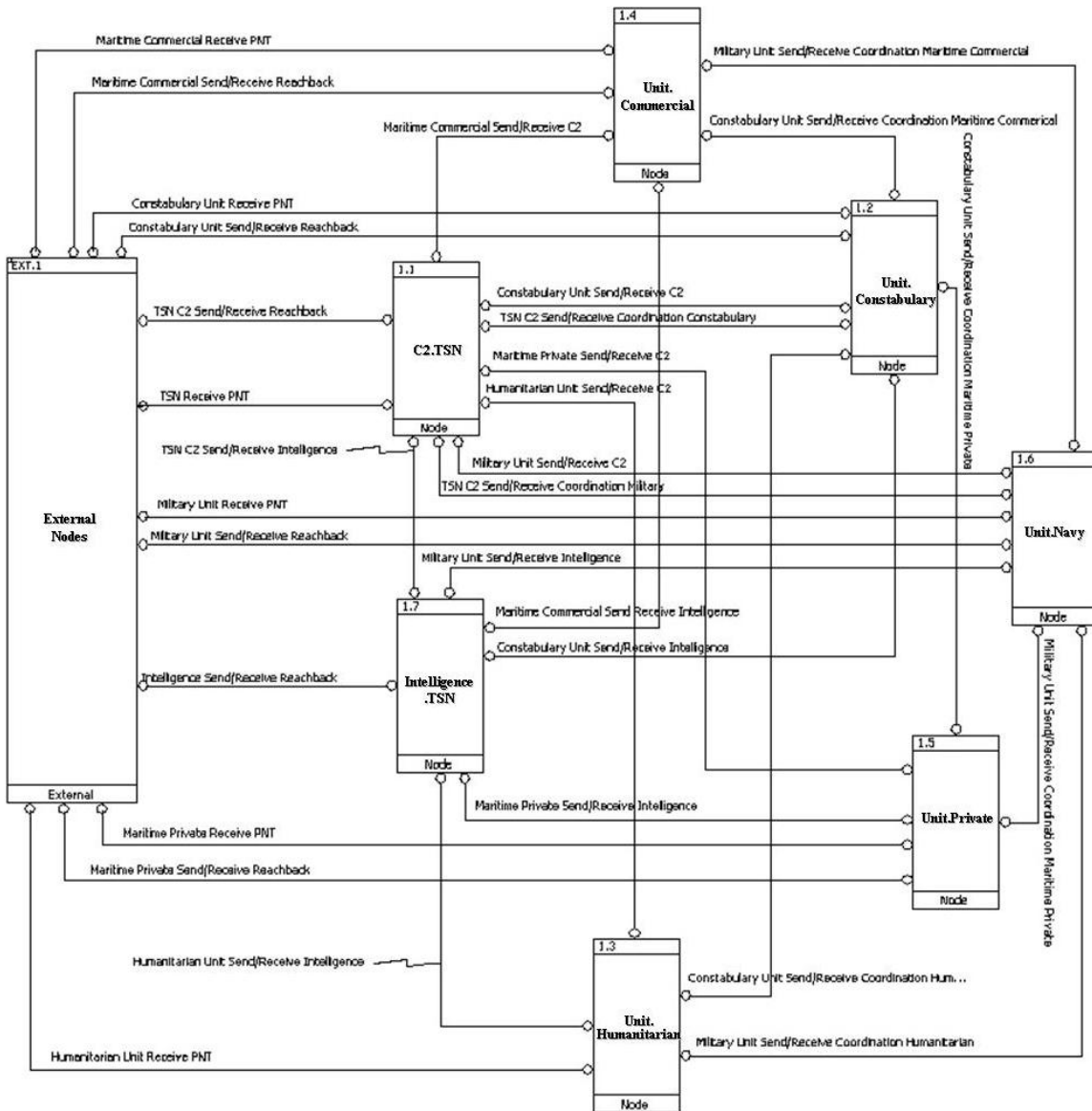

Figure 35. TSN Needlines Operational Node Diagram.

The TSN needlines represents information interaction among TSN Nodes and External Entities.

Node	Needlines
C2.TSN	Constabulary Unit Send/Receive C2 Humanitarian Unit Send/Receive C2 Maritime Commercial Send/Receive C2 Maritime Private Send/Receive C2 Military Unit Send/Receive C2 TSN C2 Send/Receive Intelligence TSN C2 Send/Receive Reachback TSN C2 Send/Receive Coordination Constabulary TSN Receive PNT TSN C2 Send/Receive Coordination Military
Unit.Constabulary	Constabulary Unit Send/Receive C2 Constabulary Unit Send/Receive Intelligence Constabulary Unit Receive PNT Constabulary Unit Send/Receive Coordination Humanitarian Constabulary Unit Send/Receive Reachback Constabulary Unit Send/Receive Coordination Maritime Commercial Constabulary Unit Send/Receive Coordination Maritime Private TSN C2 Send/Receive Coordination Constabulary
Unit.Humanitarian	Constabulary Unit Send/Receive Coordination Humanitarian Humanitarian Unit Send/Receive C2 Humanitarian Unit Send/Receive Intelligence Humanitarian Unit Receive PNT Military Unit Send/Receive Coordination Humanitarian
Unit.Commercial	Constabulary Unit Send/Receive Coordination Maritime Commercial Maritime Commercial Send/Receive C2 Maritime Commercial Send Receive Intelligence Maritime Commercial Receive PNT Maritime Commercial Send/Receive Reachback Military Unit Send/Receive Coordination Maritime Commercial
Unit.Private	Constabulary Unit Send/Receive Coordination Maritime Private Maritime Private Send/Receive C2 Maritime Private Send/Receive Intelligence Maritime Private Receive PNT Maritime Private Send/Receive Reachback Military Unit Send/Receive Coordination Maritime Private

Node	Needlines
Unit.Navy	Military Unit Send/Receive Intelligence Military Unit Receive PNT Military Unit Send/Receive Reachback Military Unit Send/Receive Coordination Humanitarian Military Unit Send/Receive C2 Military Unit Send/Receive Coordination Maritime Commercial Military Unit Send/Receive Coordination Maritime Private TSN C2 Send/Receive Coordination Military
Intelligence.TSN	Constabulary Unit Send/Receive Intelligence Humanitarian Unit Send/Receive Intelligence Maritime Commercial Send Receive Intelligence Maritime Private Send/Receive Intelligence Military Unit Send/Receive Intelligence TSN C2 Send/Receive Intelligence Intelligence Send/Receive Reachback
External Nodes	Constabulary Unit Send/Receive Reachback Maritime Commercial Send/Receive Reachback Maritime Private Send/Receive Reachback Unit Send/Receive Reachback TSN C2 Send/Receive Reachback Intelligence Send/Receive Reachback

Table 10. TSN Operational Nodes and Needlines.

TSN nodes are connected by needlines.

5. Operational Scenarios

TSN missions are refined with the description of operational scenarios. Each operational scenario employs a unique set of operational functions which correspond to an operational process. The following operational scenarios are described for TSN: evaluate range of options; collect and distribute intelligence; situation awareness, transnational threat; humanitarian aid; and disaster relief/protect environment.

The diagrams provided for the scenarios are shown as multi-threaded multi-instance diagrams where each thread is allocated to an operational node. This complex style of modeling, compared to a FFBD single thread, models behavior characteristics which are useful for depicting scenarios. For convenience the diagrams are labeled FFBD vice state machines to mask the subtlety employed.

a. Evaluate Range of Options Operational Scenario

The evaluate range of options operational scenario, Figure 36, describes how TSN transforms international policy, objective state and ROEs into tactical constructs. An external international body, IMB or IMO, issues guidance to TSN concerning expectations and restrictions which are based on international community consensus building in reaction to historical and current events.

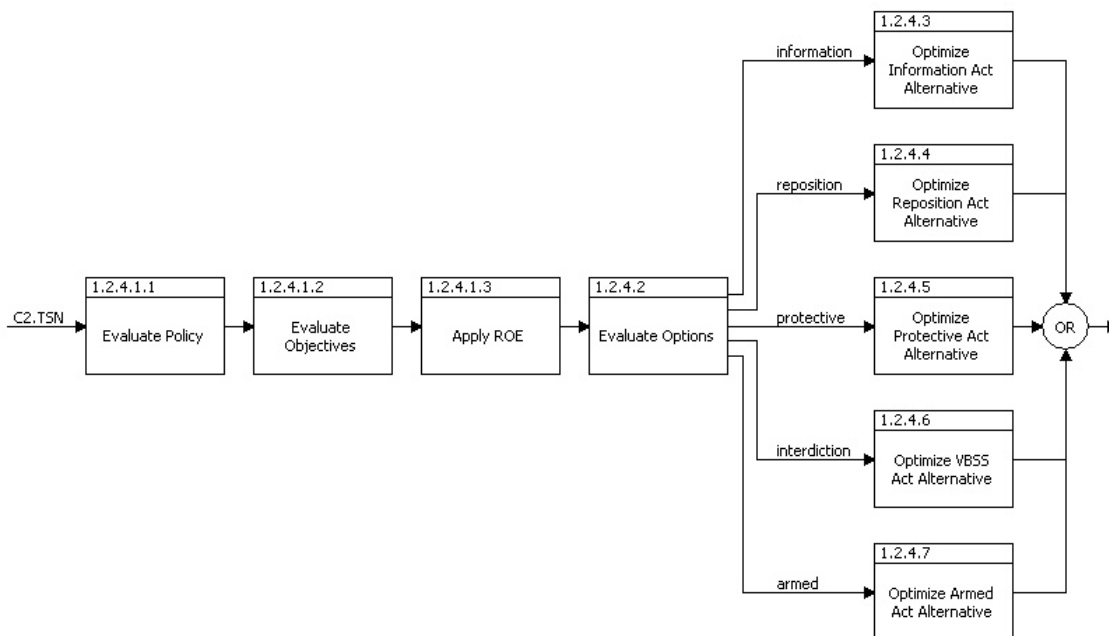

Figure 36. TSN Evaluate Range of Options Operational Scenario FFBD.
TSN Evaluate Range of Options Operational Scenario transforms international policy to tactical constructs.

Tactical options range from information gathering to armed resolution of the situation. The options are evaluated with respect to changes of international policy and in the context of the region and its national authorities. The most benign option is gathering additional information which is enabled by an intelligence tasking request from the Intelligence node. The means of information collection might be constrained by international or internal policy. The next two acts escalate the response to performing an act to influence the behavior of other vessels or persons. The tactics employed may be restricted to avoid creating an international incident or violating Admiralty Law. The

Visit, Board, Search and Seizure (VBSS) category involves contact with a vessel or persons on a vessel. The decisions involved with implementing any one of these specific acts and corresponding tactics are restricted by international and internal policies.

b. Collect and Distribute Intelligence Operational Scenario

The collect and distribute intelligence operational scenario, Figure 37, describes how TSN performs intelligence collection, processing, and distribution.

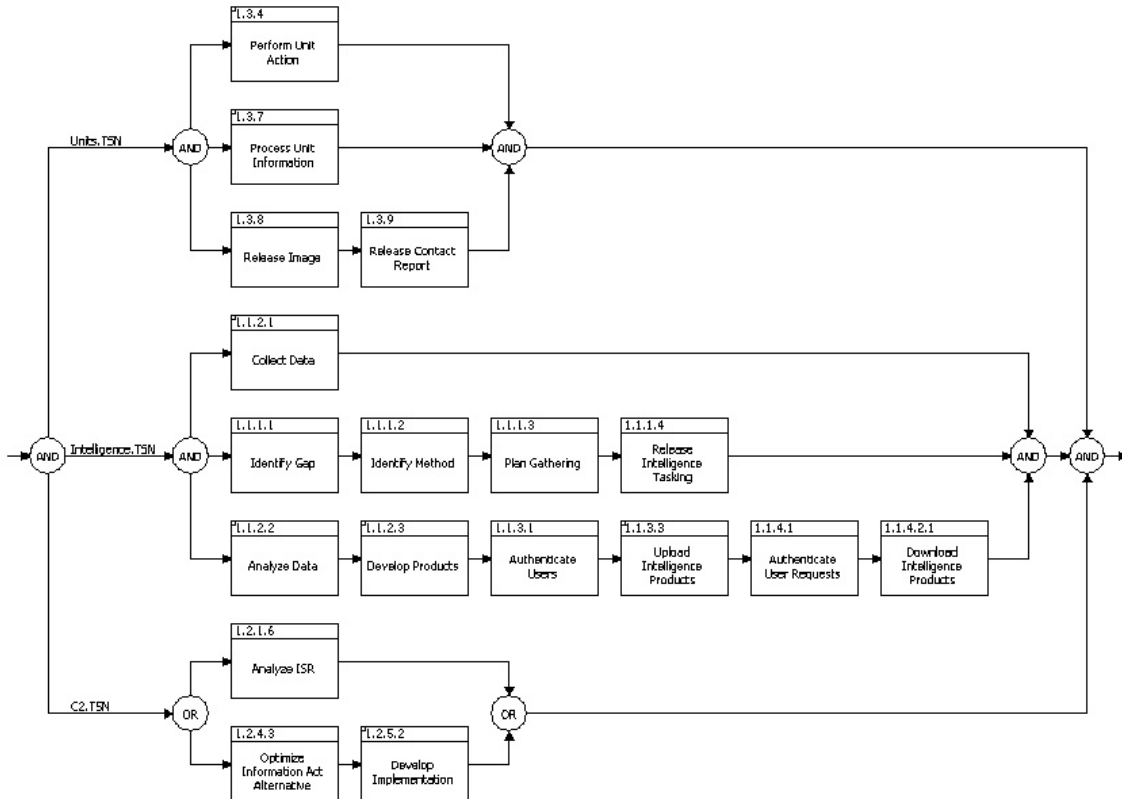

Figure 37. TSN Collect and Distribute Intelligence Operational Scenario FFBD.
TSN Collects and Distribute Intelligence Operational Scenario builds products for Command and Control, and TSN Unit Operational Nodes.

Sources of intelligence include the military, law enforcement, TSN stakeholders and open sources. TSN continuously prepares intelligence products from TSN stakeholders and open sources while intelligence received from military and law enforcement is available on a restricted basis in response to an incident. This approach

acknowledges the sensitivities of nation-states to access their intelligence sources without which they would not likely participate in TSN C4I.

The principal operational nodes involved in the scenario are command and control, intelligence, and TSN units, i.e., navy and constabulary. The intelligence node provides related products such as alerts, reports, bulletins, criminal records, fingerprints, and photos. Release of this information is either arranged by means of a memorandum of understanding or in response to a specific request by the TSN intelligence node on behalf of the command and control node. Essentially, the intelligence node collects disparate information, analyzes the information, fuses information, and releases products to the command and control and units operational nodes. TSN units may be tasked by the Intelligence node to collect information on a vessel or person.

c. Situation Awareness Operational Scenario

The situation awareness operational scenario, Figure 38, describes how TSN builds situation awareness for the TSN stakeholders. Sources of information include external sources from legacy regional maritime systems, such as, SHIPLOC, AIS, LRIT, and PRC. Additional external sources include regional environment monitoring agencies and GMDSS. The intelligence node combines TSN unit node, i.e., navy, constabulary, sensed tracks with external information to generate operational pictures. For information management purposes, the operational picture has three versions consistent with the concept of operations.

The versions of the operational picture are differentiated by the levels of stakeholder trust and need. For example, navy and constabulary units are assumed to have the highest trust and need, whereas, private vessels likely have the least trust and need. As a result the operational picture version accessible to naval and constabulary forces contains tactical content authorized and where permitted source information, whereas, the operational version accessible to private vessels contains vessel content only.

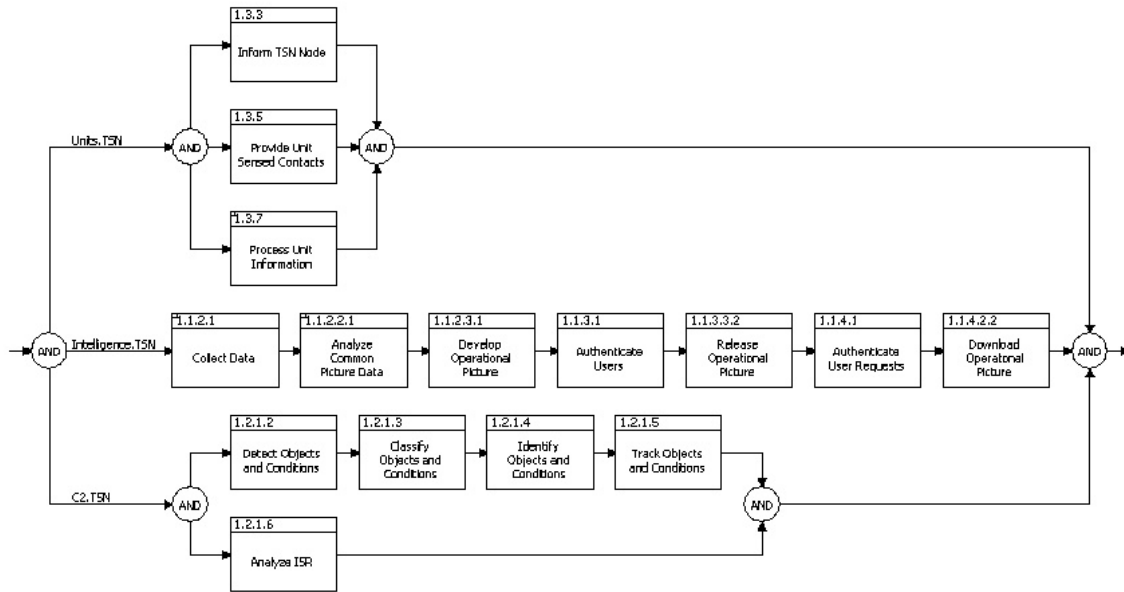

Figure 38. TSN Situation Awareness Operational Scenario FFBD.

TSN Situation Awareness Operational Scenario prepares a situation awareness view for TSN stakeholders.

d. Transnational Threat Operational Scenario

The transnational threat operational scenario, Figure 39, describes how military and law enforcement nodes conduct mutual enforcement operations. The Intelligence node continues to process and post intelligence summaries and versions of the operational picture for authorized users. The command and control node develops alternatives from the enforcement mandate and then transforms them into tactical options. Candidate tactical actions are selected to a definite course of action by predictive analysis supported by historical patterns. The TSN unit node, i.e., navy and constabulary, while aware of the intelligence summaries and an operational picture responds to the directed course of action.

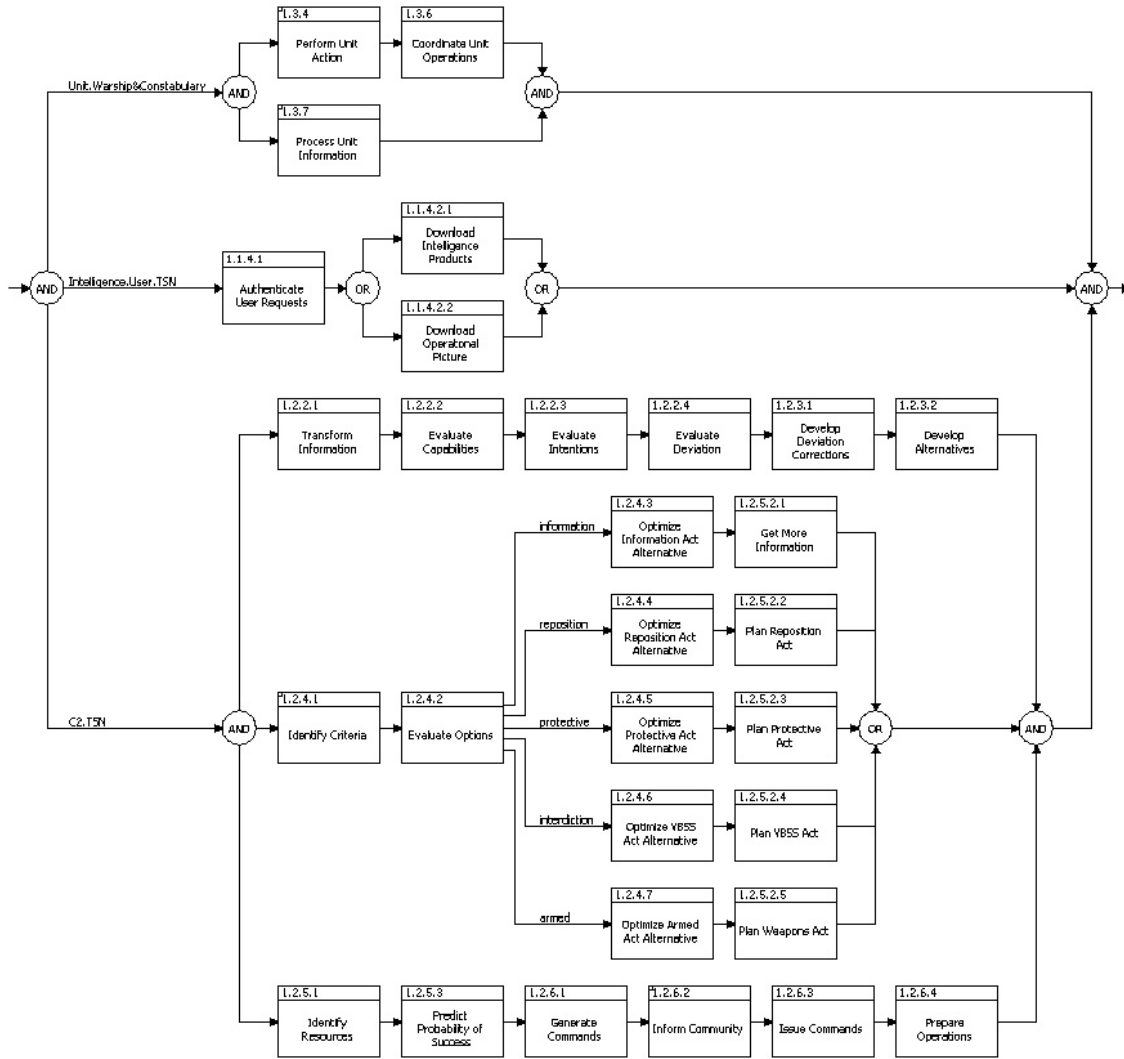

Figure 39. TSN Transnational Threat Operational Scenario FFBD.

TSN Transnational Threat Operational Scenario describes the response to suspect and overt criminal acts on the high seas and territorial waters.

e. Deliver Humanitarian Aid Operational Scenario

The deliver humanitarian aid operational scenario, Figure 40, describes how humanitarian aid stakeholders or regional nation-state authorities coordinate with TSN forces to safely deliver aid. External entities request the safe delivery of aid to disadvantaged locations or disaster areas. The command and control node responds to the request by assessing any additional mission requirements from TSN operations. Given the range of possible methods for safe delivery of aid, TSN options are evaluated to

determine the preferred course of action. A course of action is composed and communicated to the TSN unit node, i.e., navy, constabulary, humanitarian, commercial, and private.

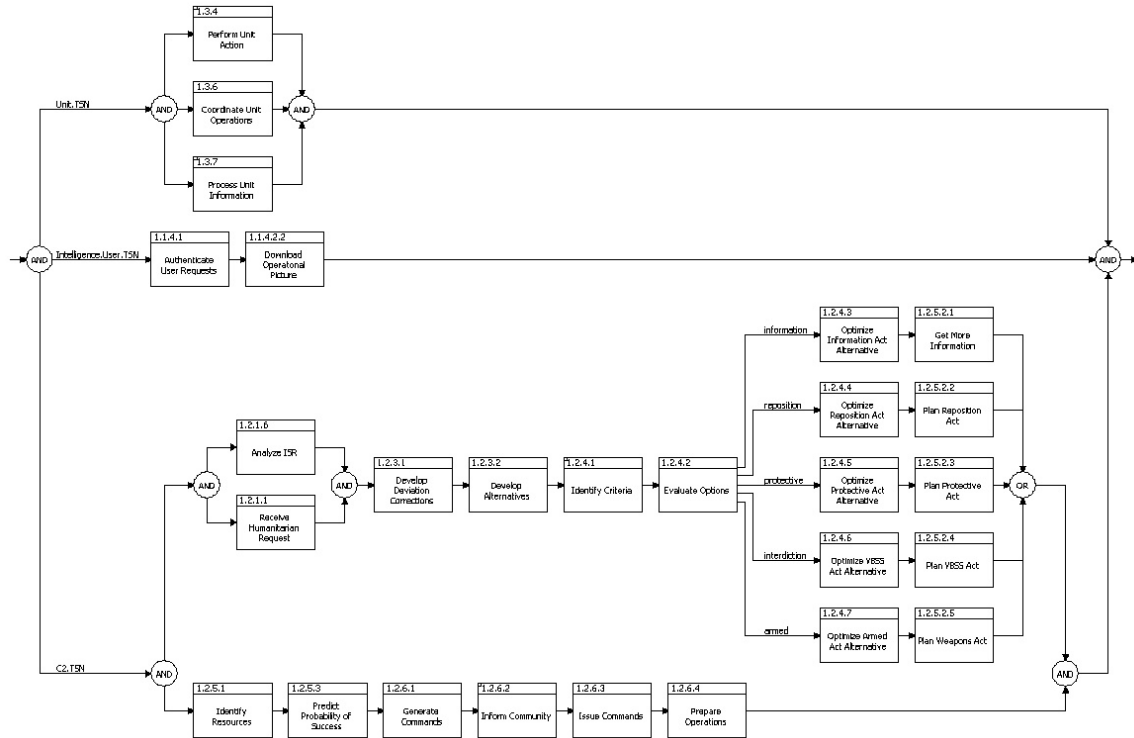

Figure 40. TSN Deliver Humanitarian Aid Operational Scenario FFBD
TSN Deliver Humanitarian Aid Operational Scenario describes the response to requests by the Humanitarian Aid stakeholder or regional nation-state authorities.

f. Disaster Relief/Protect Environment Operational Scenario

The disaster relief/protect environment operational scenario, Figure 41, describes TSN response to disasters and environment protection events. Notification of disasters and environment protection issues are provided by external entities and TSN Unit nodes, i.e., navy, constabulary, humanitarian, commercial, and private. Of particular interest, the TSN unit node may provide information to either a land node or TSN. In the former case the land node, external entity, alerts TSN. In this case the TSN response is limited to three options: obtain more information, perform reposition act, and perform a protective act. The protective act may involve the immediate application of available TSN force resources such as fuel, water, food, and assessment teams. By contrast to the

other operational scenarios, minimal planning is conducted. At some point the disaster relief mission component evolves to a humanitarian aid mission which includes extensive planning.

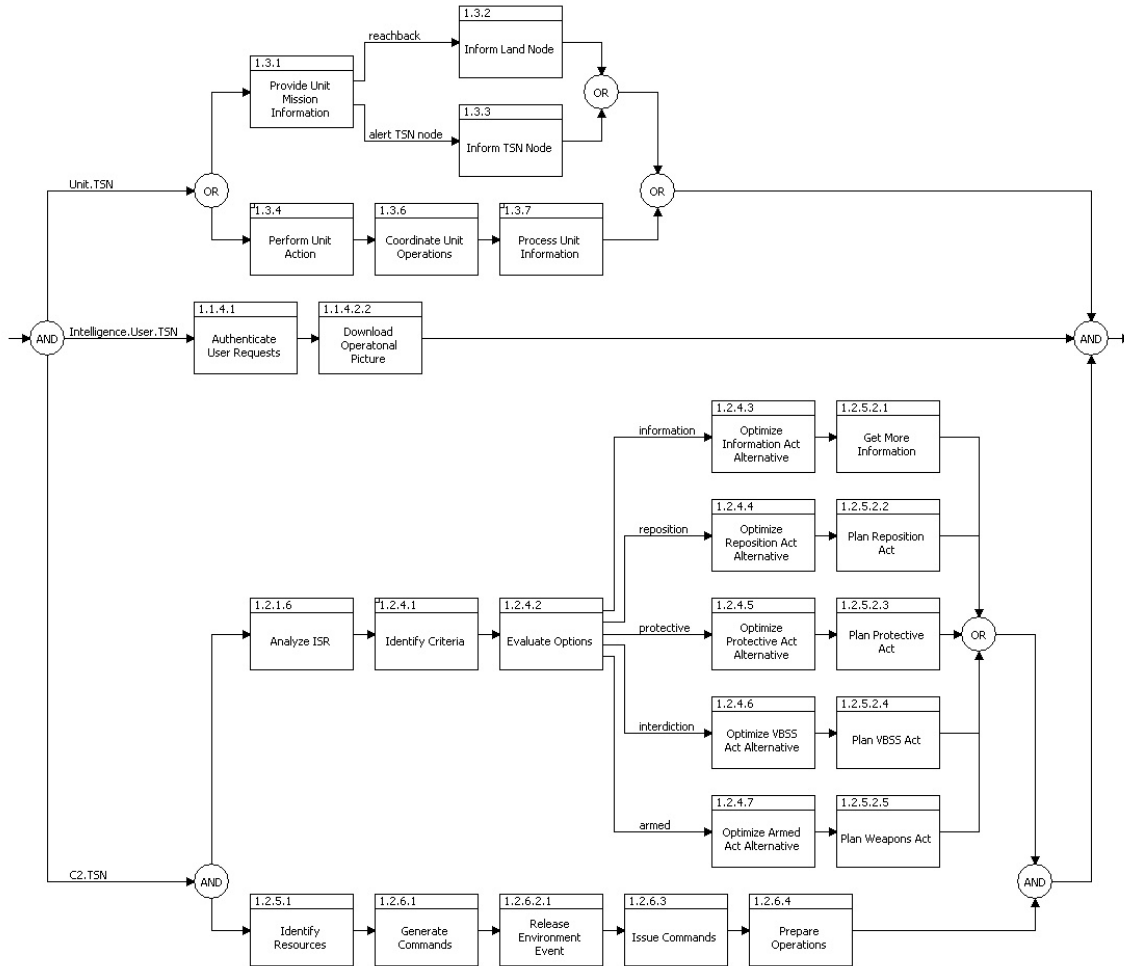

Figure 41. TSN Disaster Relief/Protect Environment Operational Scenario FFBD.

TSN Disaster Relief/Protect Environment Operational Scenario describes the response to disasters and environment governance.

6. Estimate of Mission Success

Mission success results are derived from MOEs and MOPs for each operational scenario: transnational threat enforcement, humanitarian aid, and disaster relief/protect environment response. The operational scenario with the highest mission success is

disaster relief/protect environment with 75 percent followed by humanitarian aid with 64 percent and last by the transnational threat enforcement with 63 percent. The arrangement of mission functions and their quantity determine the mission success.

For this study all level four mission functions, denoted by the function number (level 1 dot level 2 dot level 3 dot level 4), MOPs are assumed to be 0.9772 probability of success. Additionally, the level three mission functions of the operate unit operational function are also assumed to be 0.9772 since the lower level functions of the operate unit operational function are not developed.

The disaster relief/protect environment high mission success is achieved with fewer functions since in this operational scenario TSN reacts to events with minimal planning. On the other hand, the transnational threat enforcement low mission success is the effect of additional functions to safely conduct a response.

a. Transnational Threat Enforcement Mission Success

Mission Function (level three)	Operational Function	Calculated MOE (%)	Serial Sub-Functions (level four)	Serial MOP (%) Total	Parallel Sub-Functions (level four)	Parallel MOP (%) Total
1.1.4	Use Intelligence Products	0.977	1.1.4.1	0.977	1.1.4.2.1, 1.1.4.2.2	0.999
1.2.2	Assess Intentions and Capabilities	0.912	1.2.2.1, 1.2.2.2, 1.2.2.3, 1.2.2.4	0.912	n/a	n/a
1.2.3	Generate COAs	0.955	1.2.3.1, 1.2.3.2	0.955	n/a	n/a
1.2.4	Select Alternatives	0.933	1.2.4.1, 1.2.4.2, 1.2.4.3-7	0.933	n/a	n/a
1.2.5	Plan Details	0.933	1.2.5.1-5, 1.2.5.1, 1.2.5.3	0.933	n/a	n/a
1.2.6	Direct Response	0.912	1.2.6.1, 1.2.6.2, 1.2.6.3, 1.2.6.4	0.912	n/a	n/a
1.3.4	Perform Unit Action	0.977	n/a	n/a	n/a	n/a
1.3.6	Coordinate Unit Operations	0.977	n/a	n/a	n/a	n/a
1.3.7	Process Unit Information	0.977	n/a	n/a	n/a	n/a
Transnational Threat Enforcement Mission Success		0.630				

Table 11. TSN Mission Success for Transnational Threat Enforcement.
The TSN mission success for the Transnational Threat Enforcement is 63 percent assuming a 0.9772 probability of success of lower level operational functions.

The calculation of transnational threat enforcement mission success is based upon the operational function structure depicted in Figure 39. Shown in this figure, level three and level four mission functions are combined into an overall mission success value, Table 11. The function level number correlates to the operational function name which matches the operational functions developed by the dendritic method. Corresponding MOEs are calculated for each operational function based on the product of the sub-function, level four. In Table 11, each sub-function is listed with a corresponding calculated MOP on the basis of a serial and/or parallel arrangement. The effect is a mathematical representation of the mission process for developing MOEs and overall mission success. A graphical depiction of how the MOEs contribute to the overall mission success is shown in Figure 42.

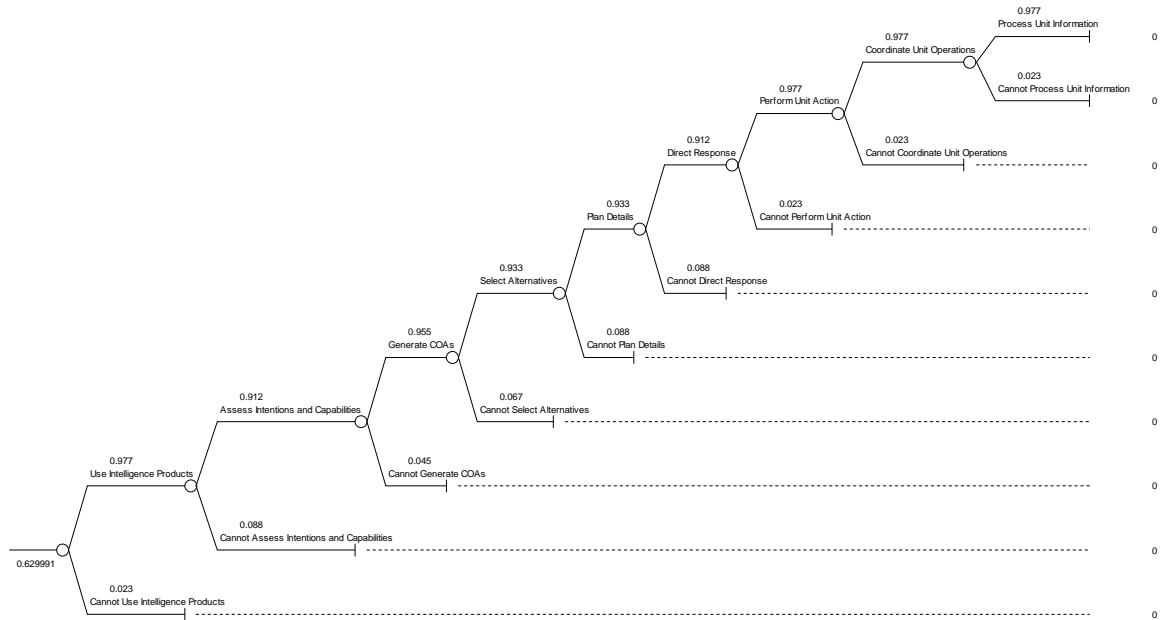

Figure 42. TSN Transnational Threat Enforcement Mission Tree Analysis.
The TSN Transnational Threat Enforcement mission tree shows the serial sequence of ten operational functions needed to achieve mission success.

b. Humanitarian Aid Mission Success

The calculation of humanitarian aid mission success is based on the operational function structure depicted in Figure 40. Shown in this figure, level three and level four mission functions are combined into an overall mission success value, Table

12. The function level number correlates to the operational function name which matches the operational functions developed by the dendritic method. Corresponding MOEs are calculated for each operational function based on the product of the sub-function, level four. In Table 12, each sub-function is listed with a corresponding calculated MOP on the basis of a serial and/or parallel arrangement. The effect is a mathematical representation of the mission process for developing MOEs and overall mission success. A graphical depiction of how the MOEs contribute to the overall mission success is shown in Figure 43.

Mission Function (level three)	Operational Function	Calculated MOE (%)	Serial Sub-Functions (level four)	Serial MOP (%) Total	Parallel Sub-Functions (level four)	Parallel MOP (%) Total
1.1.4	Use Intelligence Products	0.955	1.1.4.1, 1.1.4.2.2	0.955	n/a	n/a
1.2.1	Sense Environment	0.955	1.2.1.1, 1.2.1.6	0.955	n/a	n/a
1.2.3	Generate COAs	0.955	1.2.3.1, 1.2.3.2	0.955	n/a	n/a
1.2.4	Select Alternatives	0.933	1.2.4.1, 1.2.4.2, 1.2.4.3-7	0.933	n/a	n/a
1.2.5	Plan Details	0.933	1.2.5.1-5, 1.2.5.1, 1.2.5.3	0.933	n/a	n/a
1.2.6	Direct Response	0.912	1.2.6.1, 1.2.6.2, 1.2.6.3, 1.2.6.4	0.912	n/a	n/a
1.3.4	Perform Unit Action	0.977	n/a	n/a	n/a	n/a
1.3.6	Coordinate Unit Operations	0.977	n/a	n/a	n/a	n/a
1.3.7	Process Unit Information	0.977	n/a	n/a	n/a	n/a
Humanitarian Aid Mission Success		0.645				

Table 12. TSN Mission Success for Humanitarian Aid.

The TSN mission success for the Humanitarian Aid is 64 percent assuming a 0.9772 probability of success of lower level operational functions.

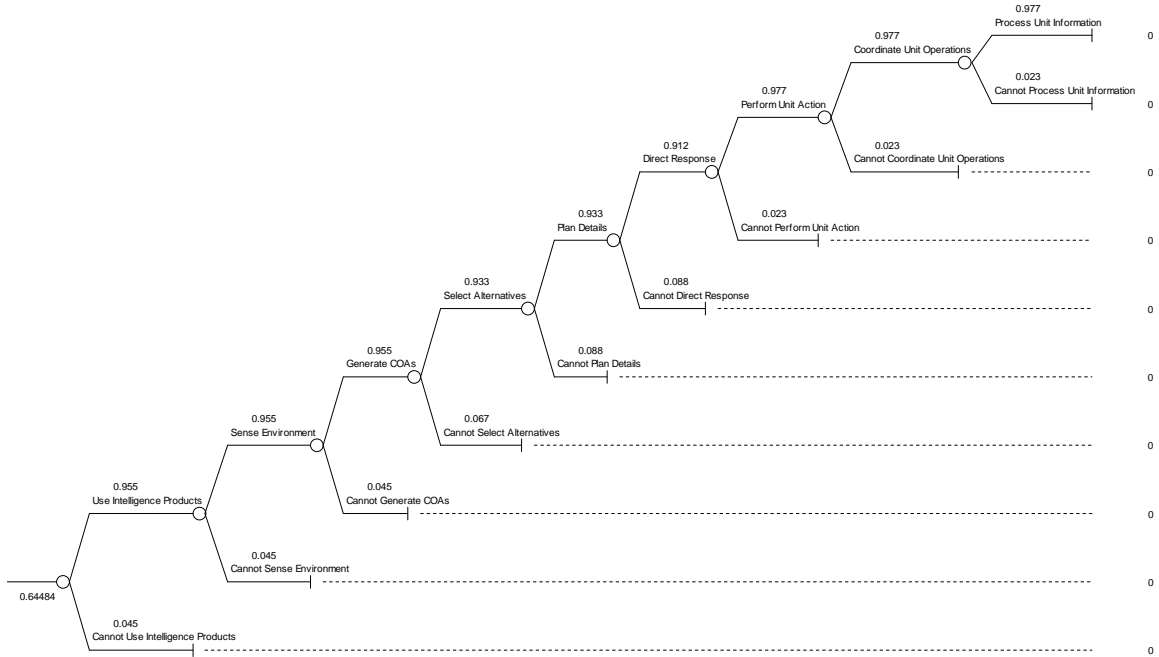

Figure 43. TSN Humanitarian Aid Mission Tree Analysis.

The TSN Humanitarian Aid mission tree shows the serial sequence of nine operational functions needed to achieve mission success.

c. Disaster Relief/Protect Environment Response Mission Success

The calculation of transnational threat enforcement mission success is based on the operational function structure depicted in Figure 41. Shown in this figure, level three and level four mission functions are combined into an overall mission success value, Table 13. The function level number correlates to the operational function name which matches the operational functions developed by the dendritic method. Corresponding MOEs are calculated for each operational function based on the product of the sub-function, level four. In Table 13, each sub-function is listed with a corresponding calculated MOP on the basis of a serial and/or parallel arrangement. The effect is a mathematical representation of the mission process for developing MOEs and overall mission success. A graphical depiction of how the MOEs contribute to the overall mission success is shown in Figure 44.

Mission Function (level three)	Operational Function	Calculated MOE (%)	Serial Sub-Functions (level four)	Serial MOP (%) Total	Parallel Sub-Functions (level four)	Parallel MOP (%) Total
1.1.4	Use Intelligence Products	0.955	1.1.4.1, 1.1.4.2.2	0.955	n/a	n/a
1.2.1	Sense Environment	0.977	1.2.1.6	0.977	n/a	n/a
1.2.4	Select Alternatives	0.933	1.2.4.1, 1.2.4.2, 1.2.4.3-7	0.933	n/a	n/a
1.2.5	Plan Details	0.955	1.2.5.1-5, 1.2.5.1	0.955	n/a	n/a
1.2.6	Direct Response	0.912	1.2.6.1, 1.2.6.2.1, 1.2.6.3, 1.2.6.4	0.912	n/a	n/a
1.3 top branch		0.977	1.3.1	0.977	1.3.2, 1.3.3,	0.999
1.3 lower branch		0.933	1.3.4, 1.3.2, 1.3.3	0.933	n/a	n/a
1.3 total	Operate Unit	0.998				
Disaster Relief/Protect Environment Response Mission Success		0.757				

Table 13. TSN Mission Success for Disaster Relief/Protect Environment.

The TSN mission success for the Disaster Relief/Protect Environment is 75 percent assuming a 0.9772 probability of success of lower level operational functions.

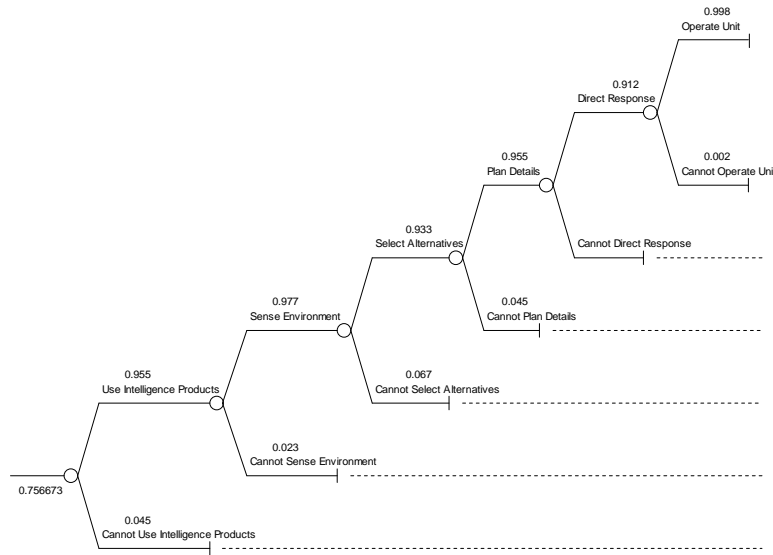

Figure 44. TSN Disaster Relief/Protect Environment Mission Tree Analysis.

The TSN Disaster Relief/Protect Environment mission tree applies both the serial and parallel sequences of operational functions needed to achieve mission success.

7. Operational Architecture Assessment

The resultant ISM and DSM analysis indicates reasonable allocation of functions to nodes. Using the ISM technique the cluster factor is 1.8 where 1.0 is the ideal value. Based on a different methodology the DSM analysis offers further insight regarding the assignment of function to structure.

\$root		External Entity Node	Task Data Collector	Process Data	Post Intelligence Products	Use Intelligence Products	Sense Environment	Assess Intentions and Capabilities	Generate COAs	Select Alternatives	Plan Details	Direct Response	Unit Node
		1	2	3	4	5	6	7	8	9	10	11	12
External Entity Node	1	1										1	1
Intell Node	Task Data Collection	2	3	1									
	Process Data	3	1	2		1	1	1					1
	Post Intelligence Products	4		1	2								
	Use Intelligence Products	5			2	1	1	2					
C2 Node	Sense Environment	6	3		1	1	5						1
	Assess Intentions and Capabilities	7			1	2		3					
	Generate COAs	8						1	2				
	Select Alternatives	9	1						1	6			
	Plan Details	10								5	3		
Direct Response	11									1	3		
Unit Node	12		1		1							1	

Figure 45. Operational Architecture Method Analysis Summary.
DSM with a score of 72 percent substantiates ISM with score of 1.8.

DSM analysis substantiates the trend indicated by the ISM analysis. Shown in Figure 45, the summary level analysis view shows how the operational functions are grouped to operational nodes. Several observations are presented. First, the largest values tend to be closer to the diagonal than at the lower left and upper right corner which indicates lower functional coupling effects. Second, most feedback values are close to the diagonal, disregarding external constraints, which reduces feedback affecting system latency. Third, the apparent cluster bounded by Use Intelligence Products, upper left corner, and Assess Intentions and Capabilities, lower right corner, is a false cluster.

Analysis indicates that forming this group into a node reduces overall system stability score by 10 percentage points. The effect of clustering and directional dependencies yields a system stability score of 72 percent where 100 percent is the ideal.

8. Operational Requirements

The following are a list of operational requirements derived by the study based on their research and the results of functional analysis.

- The TSN C4I system operational availability must be 0.99 (threshold).
- The TSN C4I system must support 24/7 continuous operations.
- The TSN C4I system should operate in all climate zones.
- The TSN C4I system should be suitable for vessels with Gross Weight Tonnage (GWT) > 300 tons (threshold), GWT > 1 ton (objective).
- The TSN C4I system must process maritime reports from multiple sources including AIS, LRIT, etc.
- The TSN C4I system must process intelligence information from combatant ships and intelligence agencies.
- The TSN C4I system must distribute situation awareness information to commercial vessels, private vessels, combatants, humanitarian aid vessels and constabulary vessels.
- The TSN C4I system must distribute situational awareness to the shipping industry, maritime organizations, non-government organizations (WFP, IRC, etc.), ports and harbors, and enforcement agencies.
- The TSN C4I system must exchange information in multiple languages.
- The TSN C4I system must authenticate user roles to provide a trustworthy capability.
- The TSN C4I system must deny access to unauthorized users.
- The TSN C4I system should employ user internationally identifiable interfaces, templates, and protocols.
- The TSN C4I system hardware must scale effectively with respect to size, weight, and power variable for use on large (GWT > 300 tons) or small vessels (GWT > 1 ton) (objective).
- The onboard TSN C4I system cost must be less than 2 percent of the vessel's original equipment configuration cost.

9. Operational Test and Evaluation Plan

An operational test plan is provided for TSN C4I in Appendix IX.

B. SYSTEM DOMAIN

1. System Functions and Services

Level one and level two system functions of TSN C4I are shown in the functional hierarchy, Figure 46. They are arranged in an intuitive order from left to right culminating in full TSN C4I functionality. Provide C4I system function is modified from existing C4I functional capability patterns which describes implementation approaches to C4I operational requirements. An explanation of each system function follows with the top level IDEF0 diagram and each system function's IDEF0 diagram located in Appendix X.

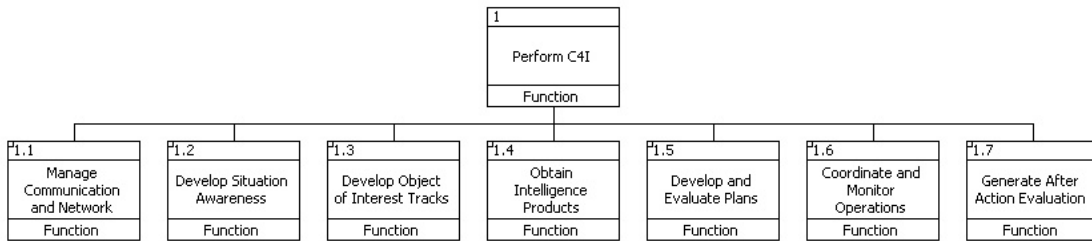

Figure 46. TSN C4I System Function Hierarchy.

TSN C4I top level functions provides full system functionality.

The manage communication and network system function provides inter-unit communications and networking, as well as, intra-unit networking to enable operational and tactical collaboration. The develop situation awareness system function provides inter-unit information from multiple sources including land based centers and TSN units. The develop object of interest system function provides declaration and development of both human and non-human track files with multimedia information. The obtain intelligence products system function provides processed intelligence to select TSN units and land based centers. The develop and evaluate plans system function provides joint TSN developed plans to: respond to disaster and environment, deliver humanitarian aid, and provide transnational threat enforcement consistent with stated international policies. The coordinate and monitor operations system function provides tactical coordination among TSN force assets while executing assigned tasks. The generate after action

Evaluation provides generation, review, and release of news briefs, situation reports, and evidence material to TSN stakeholders.

a. Operational Activities and System Function Mapping.

Operational functions are related to system functions, shown in Table 14. Of particular interest, the manage communication and network system function provides the means of information interoperability and impacts all operational activities. The remaining system functions have distinctive mapping to the operational functions.

System Functions	Operational Functions																
	Assess Intentions and	Direct Response	Generate COAs	Plan Details	Select Alternatives	Sense Environment	Post Intelligence Products	Process Data	Task Data Collection	Use Intelligence Products	Alert Land Node	Alert TSN Node	Coordinate Unit Operations	Perform Unit Action	Process Unit Information	Provide Environmental Alert	Provide Unit Sensed Contacts
Manage Communications and Networking	X	X	X	X	X	X	X	X	X	X	X	X	X	X	X	X	X
Develop Situation Awareness	X	X				X		X				X	X	X	X	X	X
Develop Object of Interest Tracks						X											X
Obtain Intelligence Products						X		X	X		X	X			X	X	
Develop and Evaluate Plans	X	X	X	X	X								X				X
Coordinate and Monitor Operations		X											X	X			
Generate After Action Evaluation		X															

Table 14. System View 5, Operational Activities to System Function Mapping.
TSN operational functions are mapped to system functions in the form of a DoDAF

SV-5.

b. Operational Information and Information Item Mapping

Operational information is related to information item, shown in Table 15. Similar in concept to the SV-5, this view describes the continuity between the operational domain information and the system domain information. Describing this continuity is an important consideration in order to support the development of a TSN data exchange standard.

Operational Domain "Operational Information"	System Domain "Information Item"
Unit Intelligence Tasking	Approved Plan
Intelligence Summary	Intelligence Information
Operational Picture	Operational Picture
Intelligence Msg	Asset Contact Report Item Asset Situation Report
Incident Person	Asset Incident Report Personal Identification Information
Request Intelligence Summary	Asset Intelligence Request
Sensed Track Files	Track Information
Request Intelligence	Request Intelligence
Incident Vessel	Asset Incident Report
Request Operational Picture	Operational Picture Request
Sensor Reports	Track Information
Environmental Alert TSN Node	Environment Event Alert
Security Incident	Asset Incident Report
Search & Rescue Msg	Maritime Search and Rescue Request Maritime Request for Assistance
Course of Action	Approved Plan
Constabulary Tasking Plan	Maritime Request for Assistance
PRC Tasking Plan	Maritime Request for Assistance
Planned Movement	Intentions and Movement Report
Environment Alert Land Node	Environment Event Alert
Environment Event	Environment Event Alert

Operational Domain "Operational Information"	System Domain "Information Item"
Evidence	Static Vessel Information Dynamic Vessel Information Voyage Vessel Information Asset Contact Report Asset Incident Report Asset Situation Report Intelligence Information Item Personal Identification Information Track Information Intelligence and Situation Awareness
Situation	Asset Situation Report
Logistics Need	Logistics Request
Status and Update Report	Asset Situation Report
Position and Timing	Navigation Information
Center LRIT Summary	Static Vessel Information Dynamic Vessel Information Voyage Vessel Information
Center AIS Summary	Static Vessel Information Dynamic Vessel Information Voyage Vessel Information
PRC Summary	Track Information
Environment Summary	Track Information
Security Alert Summary	Transnational Threat Alert Item Transnational Enforcement Event Item Transnational Threat Request for Assistance Asset Intelligence Request
Search & Rescue Summary	Track Information
Objective State	Statement of Objectives
Rules of Engagement	Rules of Engagement
Policy and Directives	Statement of Objectives
Humanitarian Request	Humanitarian Aid Request
Law Enforcement Intelligence	Intelligence Information Item Law Enforcement Blotter Personal Identification Information
Vessel Communications	Communication and Network Control Communication Management

Table 15. Operational Information to Information Item Mapping.
TSN operational information is mapped to system domain information items.

c. Manage Communication and Network

The manage communication and network system function, is composed of provide asymmetric security, provide communication, and provide networking computing system functions, located in Appendix X.

Communication management jointly manages communication links and networks with the use of a communications plan. The plan accommodates communication reach back to land sites. It also accommodates communication among vessels by Line of Sight (LOS) and Non-LOS means. Considerations of the communication plan include: disparate communication systems; data forwarding; circuit bandwidth versus data type; spectrum management; transmission security issues; authentication methods and contingency circuits. Communications network establishes connectivity between Host Nation, Regional Nation, Non-DoD National agencies, International Organizations, International Non-Government Organizations, nations' navies, and constabulary forces.

Network Operations provides continuity of operations over a range of conditions to include degraded network operations, disadvantaged network operations, limited communication bandwidth, and intermittent connectivity. The network routes information between the processing and storage components to support application services and common services. The network maintains status information regarding its nodes and interconnecting devices.

d. Develop Situation Awareness

The develop situation awareness system function is composed of collect information, fuse information, and promulgate TSN information system functions, located in Appendix X.

Situation awareness provides a graphical view of various overlays where each provides different views of information. A particular view of information may be restricted to certain stakeholders. The following overlays are included: jurisdiction, tracks (commercial, nations' navies, constabulary, etc.), density of events, planned operations

(armed, VBSS, reposition, etc.), boundaries and areas, navigation, topology, socio-political, cities and infrastructure, weather, and enforcement status/resources.

e. Develop Object of Interest Tracks.

The develop object of interest tracks system function is composed of identify object of interest, fuse object characteristics, and produce object of interest track system functions, located in Appendix X.

Tracks are developed from organic and non-organic sensors and human intelligence. Tracks are either human or non-human objects, such as vessels. If provided, the error of a track is used or estimated to associate closely-spaced tracks. Track information includes identification, priority (protected, monitored, suspicious, etc.), kinematic state, associated tracks, associated image, history, status, and assessment.

f. Obtain Intelligence Products

The obtain intelligence products system function is composed of task intelligence assets, fuse intelligence information, and promulgate TSN intelligence information system functions, located in Appendix X.

Multi-modal information sources are collected, analyzed, and correlated by TSN C4I to provide an integrated set of products for use by TSN stakeholders. Intelligence information is tagged with source, data type, date created, date accessed, keywords, abstract, size, and access restrictions. Intelligence information includes text, images, audio, video, and biometric data, i.e., fingerprints.

g. Develop and Evaluate Plans

The develop and evaluate plans system function is composed of evaluate international objective state, develop natural disaster and environment response, develop humanitarian aid response, develop transnational threat enforcement, evaluate force capability, and release plan system functions, located in Appendix X.

Plans are jointly developed and coordinated including logistic requirements for Host Nation, Regional Nation, Non-DoD National agencies, International Organizations, International Non-Government Organizations, nations'

navies, and constabulary forces. Collaborative evaluation of the plans looks for intended and unintended effects, non-lethal and lethal, of a plan in the context of the stated internationally recognized policy, and regional needs. Joint development assumes a pre-existing navy combatant and constabulary force in the area or the intent of nation-states to provide assets. A plan identifies the situation context and location with evaluated enforcement options. Each option provides compliance to international policy an ROE, basis of intelligence, needed assets and their resources, timeframe whereby option remains valid, and probability of success. The plan is generated on the basis of an enforcement concern based on intelligence assessments or as a reaction to a particular event regardless of mission type. The plan identifies significant boundaries (territorial waters, economic zone, high seas etc.), areas (military, shipping, fishing, anchorage etc.), and navigation concerns. Boundary areas and navigation concerns are superimposed with the established enforcement jurisdictional zones. Each plan summarizes responsibilities, resource needs, communication plan and tactical restrictions.

h. Coordinate and Monitor Operations

The coordinate and monitor operations system function is composed of direct TSN force assets, and release TSN force assets system functions, located in Appendix X.

Primarily navies and constabulary force assets perform tasks of a COA. They receive and evaluate information, instructions, call for backup, call for fire, declaration of intention whether hostile, friendly or unknown, coordinate vessel movements, specify handover responsibility, assess status of weapons, and perform inventory of goods and services.

i. Generate After Action Evaluation

The generate after action evaluation system function is composed of collect assessments, assess action effectiveness and promulgate report system functions, located in Appendix X.

Following an operational action or training action, a report is generated which provides a summary of action and the effect of action. Processing of the asset

reports are combined with force level planning and monitoring information to provide lessons learned for future missions, news brief for public awareness and information useful as evidence. Situation reports are generated prior to, during, and following any of the missions: disaster and environment response; humanitarian aid response; and transnational threat enforcement.

2. System Function to Components Assignment

System functions are assigned to an example component structure, shown in Figure 47. The component structure is one of several potential implementation approaches. One advantage of the software approach is portability to heterogeneous TSN stakeholder hardware environments, an advantage for the diverse TSN community. Using this approach, a cost estimate for the development effort can be easily determined.

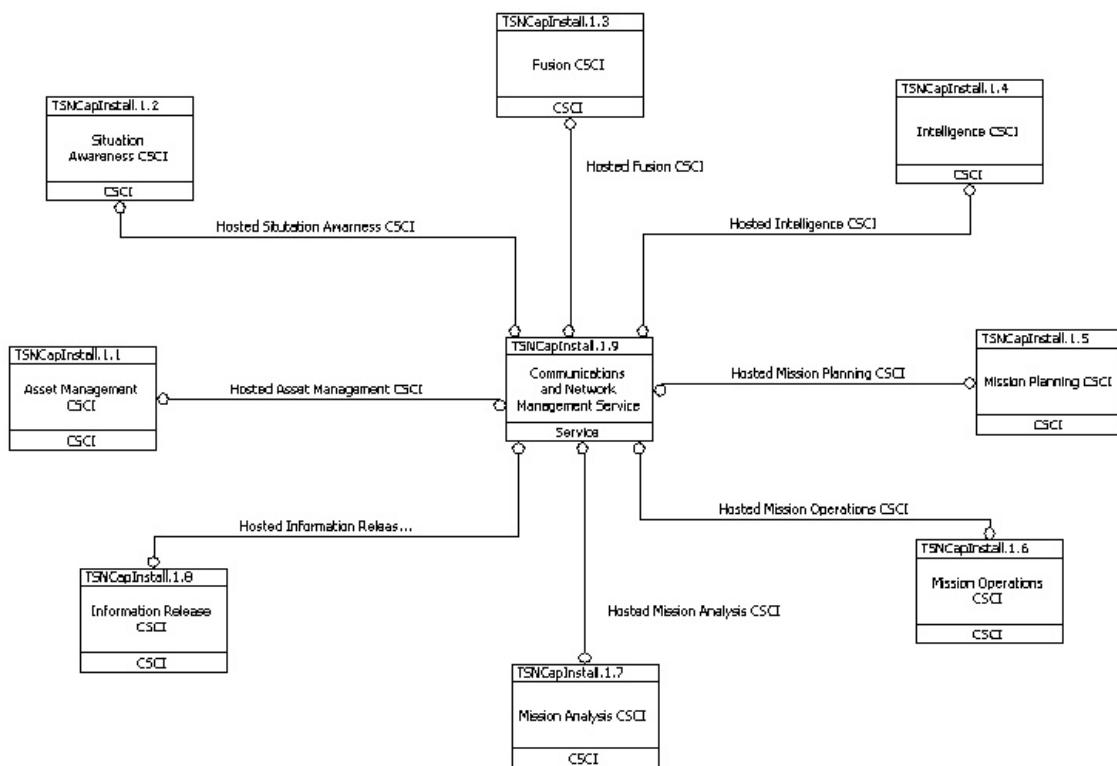

Figure 47. TSN C4I Component Physical Diagram.

The TSN C4I solution example is modified from existing technical patterns which offer solutions to meet recurring C4I system requirements. A recognizable technical

pattern based on software engineering practice is used for the TSN C4I component structure. The pattern hosts the Computer Software Configuration Items (CSCIs) on a computing network which has connectivity to the external communications system. The approach scales with the information technology infrastructure capability of the vessel and facility. As discussed in the concept of operations, scaling of functionality to fit the asset type is a TSN objective. While the analysis describing scaling is beyond the current scope of the thesis, Table 16 provides a reference baseline mapping of system functions and components.

The candidate physical structure shown as CSCIs hosted on service style architecture.

Component	Assigned System Function
Asset Management CSCI	1.2.1.1 Manage Asset List 1.6.1.1 Develop Tasks Function 1.6.2.1 Evaluate Asset Action Report Function 1.6.2.2 Release Asset Function 1.6.2.3 Update Asset Status
Situation Awareness CSCI	1.2.1.2 Request Information 1.2.1.3 Evaluate Time Varying Information 1.2.1.4 Evaluate Persistent Information 1.2.1.5 Evaluate Navigation and Timing 1.2.3.1 Populate Information Overlays 1.2.3.2 Approve Operational Picture Release
Fusion CSCI	1.2.2.1 Combine Disparate Single Sensor Information 1.2.2.2 Combine Disparate Multi-Sensor Information 1.2.2.3 Combine Disparate Data Streams 1.2.2.4 Combine Disparate Socio-Political Information 1.2.2.5 Combine Disparate Environment Features 1.2.2.6 Combine Disparate Weather Information 1.3.1.1 Classify Object Function 1.3.1.2 Validate Object Function 1.3.1.3 Verify Object Function 1.3.2.1 Combine Image Information Function 1.3.2.2 Combine Textual Information Function 1.3.2.3 Combine Video Information Function 1.3.2.4 Combine Audio Information 1.3.3.1 Manage Track File Function 1.3.3.2 Release Track Information

Component	Assigned System Function
Intelligence CSCI	1.4.1.1 Request Intelligence Information 1.4.1.2 Evaluate Received Intelligence Information 1.4.2.1 Process Open Source Information 1.4.2.2 Process Asset Provided Information 1.4.3.1 Prepare Intelligence Product 1.4.3.2 Approve Intelligence Product for Post
Mission Planning CSCI	1.5.1.1 Analyze Objectives 1.5.1.2 Reconcile Objectives Function 1.5.2.1 Prepare for Disaster or Environment Response 1.5.2.2 Update Disaster or Environment Plan Function 1.5.3.1 Develop Engineering Assistance and Construction Options 1.5.3.2 Develop Medical and Dental Assistance Options 1.5.3.3 Develop Bulk Aid Protection and Delivery Options 1.5.3.4 Evaluate Use of Force 1.5.4.1 Evaluate Criminal Profile 1.5.4.2 Anticipate Time Critical Issues 1.5.4.3 Develop Mitigation Approaches 1.5.4.4 Rank Mitigation Techniques and Plan 1.5.5.1 Assess Situation 1.5.5.2 Evaluate Asset Capability 1.5.5.3 Evaluate Criminal Capability 1.5.5.4 Predict Plan Success 1.5.6 Release Plan
Mission Operations CSCI	1.6.1.1 Develop Tasks 1.6.1.2 Coordinate Mission Tasks 1.6.1.3 Status Tasks
Mission Analysis CSCI	1.7.1.1 Compile Asset Action Reports Function 1.7.1.2 Gather Affected Area or Object of Interest Status 1.7.2.1 Reconstruct Action Events and Information 1.7.2.2 Compare Events to Plan 1.7.2.3 Develop Lessons Learned
Information Release CSCI	1.7.3.1 Prepare News Brief 1.7.3.2 Prepare Situation Report 1.7.3.3 Prepare Evidence Package

Component	Assigned System Function
Communications and Network Management Service	1.1.1.1 Provide Physical Security 1.1.1.2 Provide Communications and Transmission Security 1.1.1.3 Provide Network Security 1.1.2.1 Provide LOS/BLOS Radio 1.1.2.2 Provide Communication Network Service 1.1.3.1 Provide Network Communication Services 1.1.3.2 Provide Network Infrastructure Service 1.1.3.3 Provide COI Enterprise Service 1.1.3.4 Provide System Management Service

Table 16. Component and System Function Assignment.

TSN components are mapped to system functions.

a. Component Interfaces and Information Exchange

Software interfaces are envisioned between the components which carry information items and data payload, shown in Table 17. The interface summary in the table is expounded upon in Appendix X which provides full interface details. This data analysis provides the foundation on which the information exchange standard is based.

Component Interface	Information Item	Information Item Payload
Hosted Fusion CSCI	Static Vessel Information	1.1 Vessel Port Destination 1.2 Vessel Estimated Time of Arrival 1.3 Vessel Estimated Time of Departure 1.4 Vessel Cargo Type 1.5 Vessel Last Visited Ports 1.6 Vessel Crew Data of Birth 1.7 Vessel Crew Name 1.8 Vessel Crew Nationality 1.9 Vessel Crew Passport Number
Hosted Fusion CSCI	Dynamic Vessel Information	2.1 Vessel Status 2.2 Vessel Alerts
Hosted Fusion CSCI	Voyage Vessel Information	3.1 Vessel Location 3.2 Vessel Course 3.3 Vessel Rate of Turn 3.4 Vessel Speed

Component Interface	Information Item	Information Item Payload
Hosted Mission Planning CSCI Hosted Intelligence CSCI	Events and Requests	4.1 Humanitarian Aid Request 4.2 Disaster Event Alert 4.3 Environment Event Alert 4.4 Maritime Search and Rescue Request 4.5 Maritime Request for Assistance 4.6 Transnational Threat Alert 4.7 Transnational Enforcement Event 4.8 Transnational Threat Request for Assistance 4.9 Asset Intelligence Request 4.10 Operational Picture Request
Hosted Asset Management CSCI Hosted Mission Operations CSCI Hosted Mission Planning CSCI	Approved Plan	5.1 Asset Name 5.2 Asset Sensor Plan 5.3 Asset Movement 5.4 Asset Communication Plan 5.5 Asset Task Objective 5.6 Asset Task Restrictions 5.7 Asset Task Timeline and Actions
Hosted Asset Management CSCI Hosted Mission Operations CSCI Hosted Mission Planning CSCI	Asset Reports	6.1 Asset Contact Report 6.2 Asset Incident Report 6.3 Asset Situation Report 6.4 Intentions and Movement Report
Hosted Intelligence CSCI Hosted Situation Awareness CSCI	Open Source Information	7.1 Weather 7.2 News 7.3 Search
Hosted Fusion CSCI Hosted Intelligence CSCI	Intelligence Information	8.1 Object Name, Pseudo Name, Alias 8.2 Object Physical Characteristics 8.3 Object Recent History 8.4 Object Contact Sheet 8.5 Object Fingerprints 8.6 Object Image 8.7 Object Audio 8.8 Object Video 8.9 Object Capabilities
Hosted Intelligence CSCI	Intelligence Reports	9.1 Law Enforcement Blotter 9.2 PRC Information 9.3 AIS Information 9.4 LRIT Information 9.5 Regional Constabulary Information 9.6 Regional Military Information

Component Interface	Information Item	Information Item Payload
Hosted Mission Planning CSCI	International Objectives Control	10.1 International Authority Name 10.2 Statement of Objectives 10.3 Restrictions 10.4 Preferred Methods 10.5 Rules of Engagement 10.6 International Authority Role
Hosted Situation Awareness CSCI	Navigation Information	11.1 Navigation Message 11.2 Ephemeris 11.3 Almanac 11.4 Time Reference 11.5 Chart Data 11.6 Map Data 11.7 Navigation Reference Point
Hosted Situation Awareness CSCI	Operational Picture	12.1 Weather Overlay 12.2 Chart Overlay 12.3 Topographical Overlay 12.4 Vessel Overlay 12.5 Object of Interest Overlay 12.6 Mission Planning Overlay 12.7 Intelligence Overlay 12.8 Situation Information Request 12.9 Information Need
Hosted Fusion CSCI	Personal Identification Information	13.1 Name 13.2 Height 13.3 Weight 13.4 Hair Color 13.5 Eye Color 13.6 Ethnicity 13.7 Nationality 13.8 Address 13.9 Passport Number 13.10 National Card Identification Number
Hosted Information Release CSCI	Released Information	14.1 News Brief 14.2 Situation Report 14.3 Evidence Package
Hosted Fusion CSCI Hosted Intelligence CSCI	Request Intelligence	15.1 Object of Interest 15.2 Area of Interest 15.3 Type of Information 15.4 Timeframe of Interest 15.5 Needed Date and Time 15.6 Security and Confidentiality Certification
Hosted Fusion CSCI Hosted Situation Awareness CSCI	Track Information	16.1 Track Number 16.2 Track Type 16.3 Track Status 16.4 Track Identification 16.5 Track Location 16.6 Track Trend 16.7 Track Associations

Component Interface	Information Item	Information Item Payload
Hosted Situation Awareness CSCI	Weather Information	17.1 Region 17.2 Wave Height 17.3 Wave Period 17.4 Wave Direction 17.5 Sea State 17.6 Wind Speed Sustained 17.7 Wind Speed Gusts 17.8 Wind Direction 17.9 Visibility 17.10 Cloud Cover 17.11 Precipitation 17.12 Humidity 17.13 Sun Rise and Set 17.14 Moon Rise and Set 17.15 Tidal Conditions 17.16 Effective Period of Forecast 17.17 Barometric Pressure
Hosted Asset Management CSCI Hosted Situation Awareness CSCI	Communication Management	19.1 Outages 19.2 Planned Communication Channels 19.3 Participant List 19.4 RF Spectrum Management 19.5 Message Type and Size 19.6 Encryption List 19.7 Communication Management Downlink 19.8 Communication Management Uplink
Internal to Communications and Network Management CSCI	Network Messages	20.1 Packet Loss 20.2 Latency 20.3 Jitter 20.4 Throughput 20.5 Network Routes 20.6 Routing Protocol 20.7 Quality of Service
Hosted Asset Management CSCI Hosted Situation Awareness CSCI	Managed Asset Information	21.1 Asset ID 21.2 Asset Sensors 21.3 Asset Weapons 21.4 Asset Status 21.5 Asset Type and Characteristics 21.6 Asset Communications
Hosted Fusion CSCI Hosted Situation Awareness CSCI	Fused Information	

Component Interface	Information Item	Information Item Payload
Hosted Asset Management CSCI Hosted Mission Analysis CSCI Hosted Mission Planning CSCI Hosted Information Release CSCI	Mission Analysis	23.1 Action Assessments 23.2 Action Issues 23.3 Mission Lessons Learned 23.4 Plan Issues 23.5 Reconstructed Action 23.6 Synthesized Events and Results 23.7 Asset Status Change
Hosted Mission Planning CSCI	Mission Planning	24.1 Asset Capability 24.2 Conflicted Objectives 24.3 Criminal Capability 24.4 Disaster or Environment Response Plan 24.4.1 Disaster or Environment Response Update 24.4.2 Disaster or Environment Response Initial Plan 24.5 Humanitarian Aid Response Plan 24.6 Plan 24.7 Reconciled International Objectives 24.8 Request Criminal Response 24.9 Response Timeline 24.10 Transnational Threat Response Approaches 24.11 Transnational Threat Response Plan 24.12 Local Assessment
Hosted Asset Management CSCI Hosted Mission Analysis CSCI Hosted Mission Operations CSCI Hosted Information Release CSCI	Mission Operations	25.1 Asset Final Action Report 25.2 Asset Task Order 25.3 Asset Task Status 25.4 Coordinated Mission Tasks 25.5 Modified Tasks
Hosted Intelligence CSCI Hosted Situation Awareness CSCI	Intelligence and Situation Awareness	26.1 Classified Object 26.2 Fused Intelligence Information 26.3 Fused Object Information 26.4 Object Report 26.5 Object Track File 26.6 Validated Object

Component Interface	Information Item	Information Item Payload
Hosted Mission Planning CSCI	Logistics Request	27.1 Fuel Oil and Lubricants 27.2 Food and Provisions 27.3 Repair Parts 27.4 Medical Supplies 27.5 Port Visit Services 27.6 Personnel (linguists, cultural experts, specialists, etc.) 27.7 Munitions 27.8 Transfer and Ambulatory Service

Table 17. Information Items Carried on Component Interfaces.
TSN component interfaces carry information items and their payload.

b. Architecture Assessment

The ISM and DSM analysis indicates reasonable allocation of functions to components. Using the ISM technique the cluster factor is 1.5 where 1.0 is the ideal value. Based on a different methodology the DSM analysis offers further insight regarding the assignment of the functions to structure.

\$root	External	Asset Management CSCI	Situation Awareness CSCI	Fusion CSCI	Intelligence CSCI	Mission Planning CSCI	Mission Operations CSCI	Mission Analysis CSCI	Information Release CSCI	Communications and Network Management Service
External	1									
Asset Management CSCI	2	1						1		
Situation Awareness CSCI	3	3	1	7						
Fusion CSCI	4	3		#	4					
Intelligence CSCI	5	3		1	2					
Mission Planning CSCI	6	3	1	5		#	1	5		
Mission Operations CSCI	7	1	1				4			
Mission Analysis CSCI	8	1	1					1	4	
Information Release CSCI	9								6	
Communications and Network Management Service	10	3								

Figure 48. System Architecture Method Analysis Summary.

DSM with a score of 80 percent substantiates the ISM with a score of 1.5.

DSM analysis substantiates the trend indicated by the ISM analysis. Shown in Figure 48, the summary level analysis view shows the components and their dependencies that are based on the clustering of system functions. Several observations are presented. First, there is more forward directionality as indicated by more numbers in the lower left of the matrix as compared to the upper right of the matrix which improves overall system responsiveness. Second, the largest values tend to be closer to the diagonal than at the lower left and upper right corners which lowers functional coupling effects. Third, higher feedback values are close to the diagonal, disregarding external constraints, which reduces feedback related system latency. The effect of component clustering and directional dependencies yields a score of 80 percent where 100 percent is the ideal.

3. Information Exchange Standard

Located in Appendix XI the Information Exchange Standard is provided for the TSN C4I system. The style of the standard mimics resolutions ratified by the Maritime Security Council (MSC), a division of the IMB. Section 1 outlines the fundamental characteristics of the TSN C4I network and the scope of the standard. Section 1.2 defines the TSN C4I network, in a general sense, while Sections 1.3 and 1.4 scope the network. These three sections directly relate to the Chapter I discussion of the system's scope.

Section 2 defines the types of information to be transmitted by all non-military, participating vessels within the TSN mission area. The four information categories listed are parallel to the categories defined in the AIS Performance Standard (MSC.74 (69) Annex 3, Section 6). Setting it apart from the AIS standard is the inclusion of LRIT information, identification of the ship's flag nation, the last transmission time to the TSN C4I network, and defining the safety related information transmitted.

Section 3 elaborates on the types of external inputs with which the TSN C4I network must interface. Section 4 defines the information refresh rates in a nation's territorial waters and international waters.

Section 5 defines the unique TSN information elements. The fifteen information elements are listed below in Table 18.

Element	Nomenclature	Element	Nomenclature
TSN-001	Static Vessel Element	TSN-009	International Objectives Element
TSN-002	Dynamic Vessel Element	TSN-010	Common Operating Picture Element
TSN-003	Event and Request Element	TSN-011	Communications Link Element
TSN-004	Planning Element	TSN-012	Network Management Element
TSN-005	Asset Reporting Element	TSN-013	Tracking Element
TSN-006	Open-Source Element	TSN-014	Personal Identification Element
TSN-007	Object Information Element	TSN-015	Logistics Request Element
TSN-008	Intelligence Report Element		

Table 18. TSN C4I Network Information Elements.

TSN C4I information exchange standard comprises fifteen information elements.

These information elements are derived from the CORE® model and provide linkage between the documents. Listed with each information element are the unique information segments that are required. These segments elaborate on the information types listed in Section 2 of the standard. Included with each information element are minimum durations to maintain tactical relevancy and informational truth within a constantly evolving mission area.

Lastly, Section 6 defines both the CSCI and the Hardware Configuration Items (HWCI)s; shown in Table 19 and Table 20 respectively. The nine CSCIs and two HWCI)s are items that can be sent out for bid to industry.

CSCI	Nomenclature
SW-001	Distributed Communications and Networking Management CSCI
SW-002	Distributed Situational Awareness Development CSCI
SW-003	Information Fusion CSCI
SW-004	Distributed Intelligence Product Acquisition CSCI
SW-005	Distributed Mission Analysis CSCI
SW-006	Distributed Mission Operations CSCI
SW-007	Distributed Mission Planning CSCI
SW-008	Asset Management CSCI
SW-009	Distributed After Action Report Generation CSCI

Table 19. TSN C4I Network CSCI List.

TSN C4I is composed of nine CSCIs.

HWCI	Nomenclature
HW-001	External Communications HWCI
HW-002	Networking HWCI

Table 20. TSN C4I Network CSCI List.

TSN C4I is composed of two HWCI.

4. Critical Technical Parameters

The TSN C4I Critical Technical Parameters (CTPs), shown in Table 21, are measurable critical system characteristics that when achieved allow TSN to achieve its operational capabilities. Response time and accuracy are consistent with legacy systems, for example, AIS and LRIT. Arguably the most important parameter, language translation, enables understanding among the languages likely to be encountered by the multi-national TSN force. Reliability and continuity of operations CTPs concentrate on mission reliability.

Categories	Parameters	Values
Message Response	Situation Awareness Update	30 minutes
	Data Exchange Latency	5 minutes
Positional Accuracy	Spatial Mean Error	3 meters
Language Translation	Latency	< 10 seconds
	Accuracy	< one error per 100 words
	Language Types	English, French, Spanish, Japanese, Chinese, German
Reliability	MTBF	>500 hours
	MTTR	< 1 hour
Continuity of Operations	Recovery Time Objective	< 8 hours
	Recovery Point Objective	< 8 hours

Table 21. TSN C4I Critical Technical Parameters.

The TSN CTP identify critical performance measures to achieve operational capability.

**C. MISSION APPLICATIONS SYSTEM AND SOFTWARE
ENGINEERING COST ESTIMATE**

1. Mission Applications Systems Engineering Cost Estimate

A cost estimate for the TSN C4I system is only performed on the favored committee model approach which is a distributed system architecture involving hosted critical software mission applications. Estimating TSN’s systems engineering developmental costs begins by applying Equation (11) and defining the size drivers. First, the scale factor, *E*, from Equation (11) is set to 1.06. Then, from the derived TSN requirements in Chapter IV: Section A7, there are seven nominal and seven complex operational requirements. The operational requirements are used in place of the system requirements due to the early design nature of TSN. From the CORE model, there are four easy, thirty-six nominal, and fourteen complex interfaces. From the information standard, there are a total of fifteen TSN unique data elements. This correlates to seven nominal and eight complex algorithms. From the Operational Test and Evaluation Plan, there are six nominal operational scenarios. These values are entered into the NPS web-based COSYSMO/COCOMO II application, Figure 49.

System Size	Easy	Nominal	Difficult
# of System Requirements		7	7
# of System Interfaces	4	36	14
# of Algorithms		7	8
# of Operational Scenarios		6	

Figure 49. TSN C4I COSYSMO Size Drivers.

TSN COSYSMO size drivers are extracted from Operational Test and Evaluation Plan, Information Exchange Standard, and functional models.

Next, the COSYSMO cost drivers are defined using Dr. Valerdi’s book for guidance (Valerdi 2009). Illustrated in Figure 50, the team cost drivers, Team Cohesion (TEAM), Personnel Capability (PCAP), Personnel Experience (PEXP), and Process Capability (PCAP), are assumed to be nominal; as a baseline for estimation. The Tool

Support (TOOL) cost driver assumes that basic systems engineering tools are integrated throughout the systems engineering process; and is scored as nominal. Given that most systems engineering groups operate with wideband electronic communications, widely used and accepted collaborative tools, and are often collocated, the Multisite coordination (SITE) cost driver is scored as very high.

Stakeholder Team Cohesion	Nominal ▼
Personnel/Team Capability	Nominal ▼
Personnel Experience/Continuity	Nominal ▼
Process Capability	Nominal ▼
Multisite Coordination	Very High ▼
Tool Support	Nominal ▼

Figure 50. TSN C4I COSYSMO Team Cost Drivers.

TSN team cost drivers assume average personnel are assigned to the systems engineering developmental task; with average tools and facilities

The COSYSMO application cost drivers, shown in Figure 51, are defined in the following manner. Each stakeholder is assumed to have a reasonable understanding of both the requirements (RQMT) and architecture (ARCH); resulting in a nominal score for the RQMT and ARCH cost drivers. Knowing that failure of TSN can result in a high financial loss for these stakeholders, the Level of Service Requirement (LSCV) cost driver is scored as high. Given the scale of TSN, there must be a high amount of standards-driven Documentation (DOCU); resulting in a high score for the DOCU cost driver. Illustrated by the fielded data exchange systems listed in Chapter II, the Technological Risk (TRSK) cost driver is scored as nominal. Additionally, given the concept of operations, complex interdependencies must be coordinated; resulting in a nominal number of recursive levels in the design.

Requirements Understanding	Nominal	Documentation	High
Architecture Understanding	Nominal	# and Diversity of Installations/Platforms	Very High
Level of Service Requirements	High	# of Recursive Levels in the Design	Nominal
Migration Complexity	Very High		
Technology Risk	Nominal		

Figure 51. TSN C4I COSYSMO Application Cost Drivers.

TSN application cost drivers assume reasonable stakeholder understanding and well documented processes for future work.

The number and diversity of Installations/Platforms (INST) cost driver is an averaged value of three sub-factors: installations, operating environment, and platforms. From the concept of operations, there are 2 to 3 installation configurations and a need for TSN to be heterogeneous but compatible. From the Operational Requirements, Chapter IV: Section A7, there are ruggedized platform and information security requirements. Furthermore, like most large programs, TSN is developed using a mix of industry standard and proprietary protocols. These sub-factors correlate to an average score of very high for the INST cost driver. Lastly, the Migration Complexity (MIGR) cost driver is rated as very high due to the extensive list of legacy contractors that offer information inputs to TSN.

Entering these values into the NPS web-based application yields an effort estimation of 448 person-months. Assuming a rate of \$60/hour for all staff and a 152 hour work-month, the developmental cost for TSN’s systems engineering tasks is \$4.09M; shown in Table 22 and Figure 52.

Systems Engineering

Effort = 448 Person-months

Effort Distribution (Person-Months)

Phase / Activity	Conceptualize	Develop	Operational Test and Evaluation	Transition to Operation
Acquisition and Supply	8.8	16.0	4.1	2.5
Technical Management	16.8	29.0	19.1	11.4
System Design	45.8	53.9	22.9	12.1
Product Realization	8.8	20.2	21.5	16.8
Product Evaluation	25.0	37.6	55.7	20.9

Table 22 TSN C4I Systems Engineering Developmental Costs.

TSN systems engineering developmental costs are divided into four pre-defined phases; derived from ISO/IEC 15288: Systems Engineering – System Life Cycle Processes. (Valerdi R., 2006).

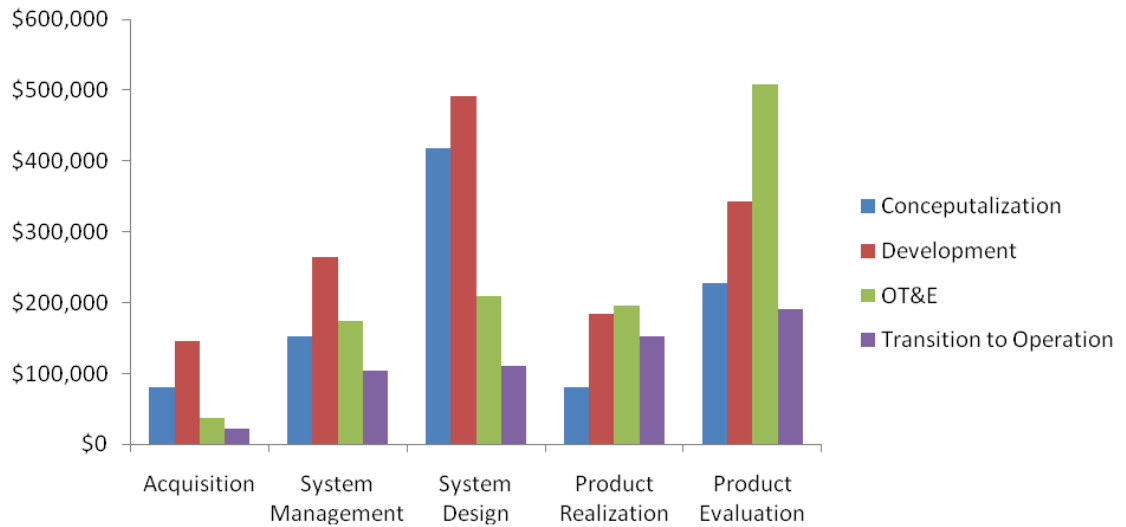

Figure 52. TSN C4I Systems Engineering Costs per Phase.

TSN systems engineering developmental costs total \$4.09M.

2. Mission Applications Software Cost Estimate

TSN's software development cost estimation begins with by defining the functional points of the system. From the CORE® model, discussed in Chapter IV, the number of external inputs, external outputs, logical internal files, external interface files, and external queries is determined. The result of this analysis is entered into the Costar™ 7.0 application; and shown in Figure 53. These function points relate to a 67,000 SLOC; regardless of computing language.

Function Point Settings for Component: TSN				
		Simple	Average	Complex
External Input	EI	1	7	1
External Output	EO	4	3	2
Logical Internal File	ILF	4	34	8
External Interface File	EIF	0	2	6
External Inquiry	EQ	0	2	3
UnAdjusted Function Points:		670		
Adjusted Function Points:		670		
Lines per Function Point:		100		
Size before REVL:		67,000		

Figure 53. TSN C4I COCOMO II functional point summary.

TSN functional points are derived from the System Functional Hierarchy diagram and CORE model.

The COCOMO II scale exponent, Equation (7) is defined in the following manner for TSN. A nominal score is applied to the five scale factors listed in Figure 54; due to the nominal degree to which past experience applies the nominal need to conform to requirements, the nominal design thoroughness, the nominal synchronization of stakeholders, and the nominal process maturity.

Precedentedness:

Development Flexibility:

Architecture / Risk Resolution:

Team Cohesion:

Process Maturity:

Figure 54. TSN C4I COCOMO II Scale Factors.

TSN scale factors assume average personnel and processes are used for the software developmental task.

The seven early design effort multipliers in COCOMO II are averages of specific groups of the post-architecture effort multipliers (Boehm et al. 2000). The values in Table 23 are assigned to their respective post-architecture effort multipliers score then averaged; to find the early design value.

Score	Value
Very Low	1
Low	2
Nominal	3
High	4
Very High	5
Extremely High	6

Table 23. Early Design Values for Post-Architecture Cost Factors (Boehm et al. 2000).

TSN early design cost factors are averaged values of specific groups of post-architecture cost factors.

Shown in Table 24, the required Reusability (RUSE) and development Schedule (SCED) effort multipliers are direct corollaries to their post-architecture effort multipliers. TSN assumes a nominal schedule constraint and reusability across the produce line; resulting in a very high RUSE score.

Early Design Effort Multiplier	Post-Architecture Effort Multiplier	Post-Architecture Score		Early Design Score	
Product Reliability and Complexity (RCPX)	Reliability (RELY)	Very High	5	5	Very High
	Database size (DATA)	High	4		
	Complexity (CPLX)	Very High	5		
	Documentation (DOCU)	Nominal	3		
Required Reusability (RUSE)	Reusability (RUSE)	Very High	5	5	Very High
Platform Difficulty (PDIF)	Time constraint (TIME)	Nominal	3	3	Nominal
	Storage constraint (STOR)	Nominal	3		
	Platform volatility (PVOL)	Nominal	3		
Personnel Capability (PERS)	Analyst capability (ACAP)	Nominal	3	3	Nominal
	Programmer capability (PCAP)	Nominal	3		
	Personnel continuity (PCON)	Nominal	3		
Personnel Experience (PREX)	Analyst experience (AEXP)	Nominal	3	3	Nominal
	Programmer experience (PEXP)	Nominal	3		
	Language experience (LTEX)	Nominal	3		
Facilities (FCIL)	Software tool usage (TOOL)	Nominal	3	4	High
	Multisite development (SITE)	Very High	5		
Development Schedule (SCED)	Development schedule (SCED)	Nominal	3	3	Nominal

Table 24. TSN C4I Early Design Cost Factors (Boehm et al. 2000).

The early design effort multipliers for TSN are averaged values of specific post-architecture effort multipliers.

The product Reliability and Complexity (RCPX) score is a combination of the four effort multiplier scores grouped in Table 24. Failure of TSN results in a high financial loss to the stakeholders, thus a very high score is set for the software Reliability (RELY) effort multiplier. Given the large amount of data handled by TSN and the complexity of interactions, the Database Size effort multiplier (DATA) is assumed to be high and the Complexity effort multiplier (CPLX) is set at very high. The lifecycle documentation effort multiplier (DOCU) is set at nominal, denoting the right size for lifecycle needs.

The Platform Difficulty (PDIF) effort multiplier is assigned a nominal value based on the following assumptions. Less than 50 percent of the available execution time and available main storage of TSN is used. Furthermore, major updates to the system are

assumed to occur only every six months; minor updates are assumed to be released bi-weekly.

The Personnel Capability (PERS) effort multiplier assumes that the analysts and programmers assigned to the development of TSN are within the 55th percentile of capability; ACAP and PCAP respectively. Another assumption is that the annual turnover rate for employees in these developmental organizations is 12 percent per year. These nominal scores for ACAP, PCAP, and PCON result in a score of nominal for PERS.

The Personnel Experience effort multiplier (PREX) is closely related to the PERS effort multiplier. It assumes that the analysts and programmers average one year of application, platform, and language/tool experience; AEXP, PEXP, and LTEX respectively. These values result in a nominal score for PREX.

The Facilities effort multiplier (FCIL) is a combination of the assumed Tool Support (TOOL) and Multisite coordination (SITE). Given that most engineering organizations are collocated when assigned to a task, and wideband communications are essentially an industry standard, the SITE effort multiplier is set at very high. Basic software tools are assumed to be moderately integrated throughout the lifecycle; denoted by the nominal score for TOOL.

These values are entered into the Costar™ application and result in a confidence level of 612.5 person-months and a schedule of 33.4 months; at 80 percent. Applying the same cost per month as the systems engineering task yields a software development lifecycle cost of \$5.59M, Figure 55.

An estimated total for developing the critical mission applications to support the TSN C4I system implementing a committee organization is the combination of both systems engineering costs and software engineering costs. With a confidence level of 50 percent for systems engineering estimate and 80 percent for software engineering estimate the total estimate cost is \$9.68 million assuming a \$60.00 labor rate.

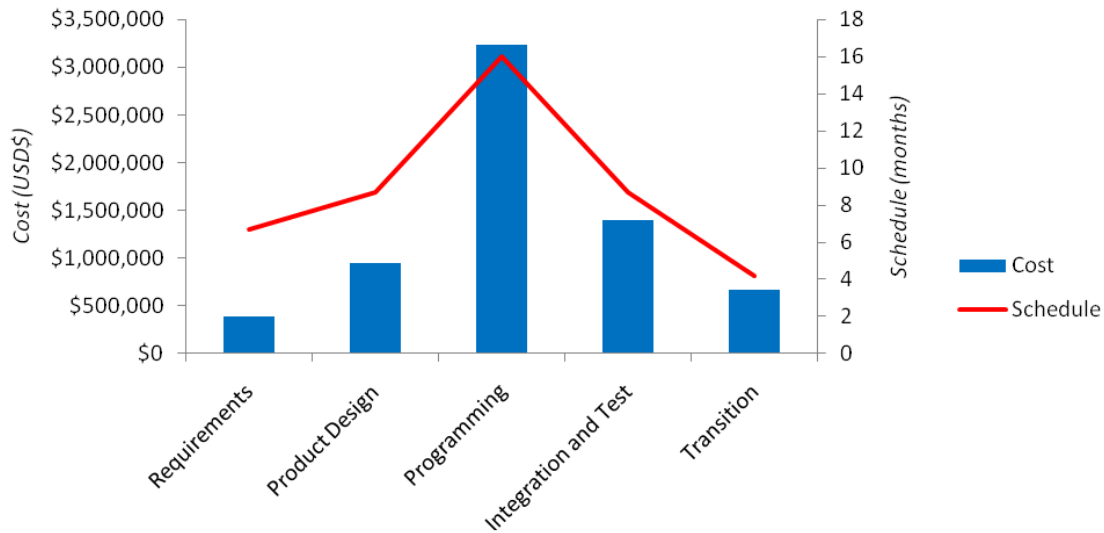

Figure 55. TSN C4I Software Development Cost Estimate.

TSN C4I software development costs total \$5.59M across the Waterfall model.

In summary the TSN C4I intends to provide C2 capability for all TSN missions by applying a committee organizational construct to its stakeholders. Supported by the AoA, the committee approach is favored over the traditional team or group approaches primarily due to political feasibility. The AoA is a weighted normalized matrix that transforms team assessments and data from nine sub-alternatives. In Arena, each model is stimulated by random events having an average occurrence of 60 hours for transnational threat enforcement, 98 hours for humanitarian aid, and 101 hours for disaster relief/protect environment response. Results from these models include resource usage and mission duration times which are used by the AoA.

Employing the committee organizational approach, three C4I tiers are used to involve stakeholders using backbone, edge and broadcast capabilities. Backbone capabilities include nations’ navies, constabulary and intelligence units with the highest access to TSN information and operations. Edge capabilities include commercial units and humanitarian organizations with access to TSN information and limited operations. Broadcast capabilities include all other stakeholders, e.g., private stakeholders, with the lowest level of access restricted to TSN situation awareness information.

TSN C4I is organized into three critical operational functions: Provide Intelligence, Perform Command and Control, and Operate Unit. Traditional operational capability patterns are used for the first two functions. The operational capability pattern for Provide Intelligence is task, process, post, and use. The operational capability pattern for Perform Command and Control is sense, assess, generate, select, plan, and direct. From functional analysis sub-functions are derived and allocated to the following operational nodes: C2, Intelligence, and Unit. The latter node is further instantiated to navy, constabulary, humanitarian, commercial, and private. Between these nodes, needlines and operational information describe the dependencies between these nodes.

From the arrangement of operational nodes an operational architecture is developed and assessed with mission success and structural analysis. The following operational scenarios have a mission success likelihood of: 75 percent for disaster relief/protect environment, 64 percent for humanitarian aid, and 63 percent for transnational threat. The difference of functional arrangements associated with each operational scenario drive separate results. Structural assessment of the operational architecture results in the following acceptable scores: a cluster factor of 1.8, where 1.0 is ideal, and a system stability of 72 percent, where 100 percent is ideal. Additionally, an operational test and evaluation plan is provided for the TSN C4I system as a validation approach, when the TSN C4I system undergoes operational testing.

A software system architecture is derived from the operational architecture that is portable across heterogeneous environments. Derived system functions are mapped to operational functions using a Department of Defense Architecture Framework version 1.5 (DoDAF) System View Five (SV-5). System sub-functions are derived and allocated to the following system architecture components: Asset Management Computer Software Configuration Item (CSCI), Situation Awareness CSCI, Fusion CSCI, Intelligence CSCI, Mission Planning CSCI, Mission Operations CSCI, Mission Analysis CSCI, Information Release CSCI, and Communications, and Network Management Service. Structural assessment of the system architecture also results in acceptable scores: a cluster factor of 1.5, where 1.0 is ideal, and a system stability of 80 percent, where 100 percent is ideal.

Determined from the operational architecture, needlines and operational information, system data items, and their interfaces are developed. On this foundation an information exchange standard is provided for the TSN C4I system. This exchange standard represents essential information elements which pass among TSN stakeholders.

As the final achievement of this study, the TSN C4I architectures are evaluated for a candidate solution development cost. An estimated total for developing the CSCIs hosted by the TSN C4I system, implementing a committee organization, is the combination of both systems and software engineering costs. With a confidence level of 50 percent for the systems engineering estimate, and 80 percent for the software engineering estimate, the total cost is \$9.68 million assuming a \$60.00 labor rate.

THIS PAGE INTENTIONALLY LEFT BLANK

V. CONCLUSION

The Global Maritime Partnership (GMP) enterprise objective is to pursue an international consensus to cooperatively provision a naval presence to stabilize global maritime operations, a concept referred to as the Thousand Ship Navy (TSN). A segment of TSN is Command, Control, Communications, and Intelligence (C4I), which provides the ability to conduct the following missions: transnational threat enforcement, humanitarian aid, and disaster relief/protect environment response. These missions are highly complex and cannot be solved by any single nation. At the USN and USCG flag level a vision has formed for Naval and Coast Guard maritime forces to combine resources. This vision endeavors to protect the Sea Lines of Communication (SLOC) from threats affecting international communities consistent with the restrictions of law.

A. PROBLEM STATEMENT

The problem addressed in this study is a lack of a C4I system enabling an international coordinated response to transnational threats, events compelling humanitarian assistance, and environment governance. Development of such a capability is confounded by the nature of internationalism. Among these obstacles are: diverse information standards, disparate communication systems, various navigation systems, dissimilar operating procedures, and an absent organizational framework. In this international setting, TSN must balance confidentiality, privacy and information exchange to support nations, businesses, and security forces' to promote participation in a voluntary TSN.

B. BACKGROUND

Chapter II discussed the historical origins of the TSN concept and its evolution over millennia. The effect of improved technology has limited battlespace volume where fewer ships are required to dominate any ocean. Subsequently, the capability of a TSN in the modern era can be achieved with a fewer number of ships. The TSN shifts the historical military coalition to an inclusive participatory and voluntary maritime alliance

with a global economy focus. Current non-military systems have solved aspects of maritime community security needs; however, a system is not in place to provide an integrated C4I architecture to coordinate transnational threat enforcement, humanitarian aid, and disaster relief/protect environment responses. Complexities of enforcement actions on high seas, economic zones and territorial waters impact TSN C4I approaches.

C.METHODOLOGY

Chapter III highlighted systems engineering methods employed by the study with the objective of developing a TSN C4I operational architecture, system architecture, information exchange standard, and corroborating analysis. Figure 56 illustrates the follow down of the process, methods, and tools used to reach the conclusions of this report. The dendritic descriptive method allowed the team to articulate operational functions and supporting functions. This enabled functional decomposition and analysis to be conducted within operational and system domains. The use of Analysis of Alternatives (AoA) was supported by Arena's Discrete Event Simulation (DES) environment that resulted in mission durations and resource usages which served as evaluation factors for the AoA. The analysis considered team, group, and committee organizational models for TSN.

Functional analysis methods transformed operational functions into system functions that enabled the determination of structure, process flow, inputs and outputs of the system domain. Allocation results were used by Interpretive Structure Matrix (ISM) and Design Structure Matrix (DSM) methods providing an assessment of dependencies and functional clustering. An additional architecture assessment of mission scenarios was described using the mission success method based upon Measures of Effectiveness (MOE) and Measures of Performance (MOP). Established from the architecture, a cost estimation method described the estimated software and systems engineering developmental costs.

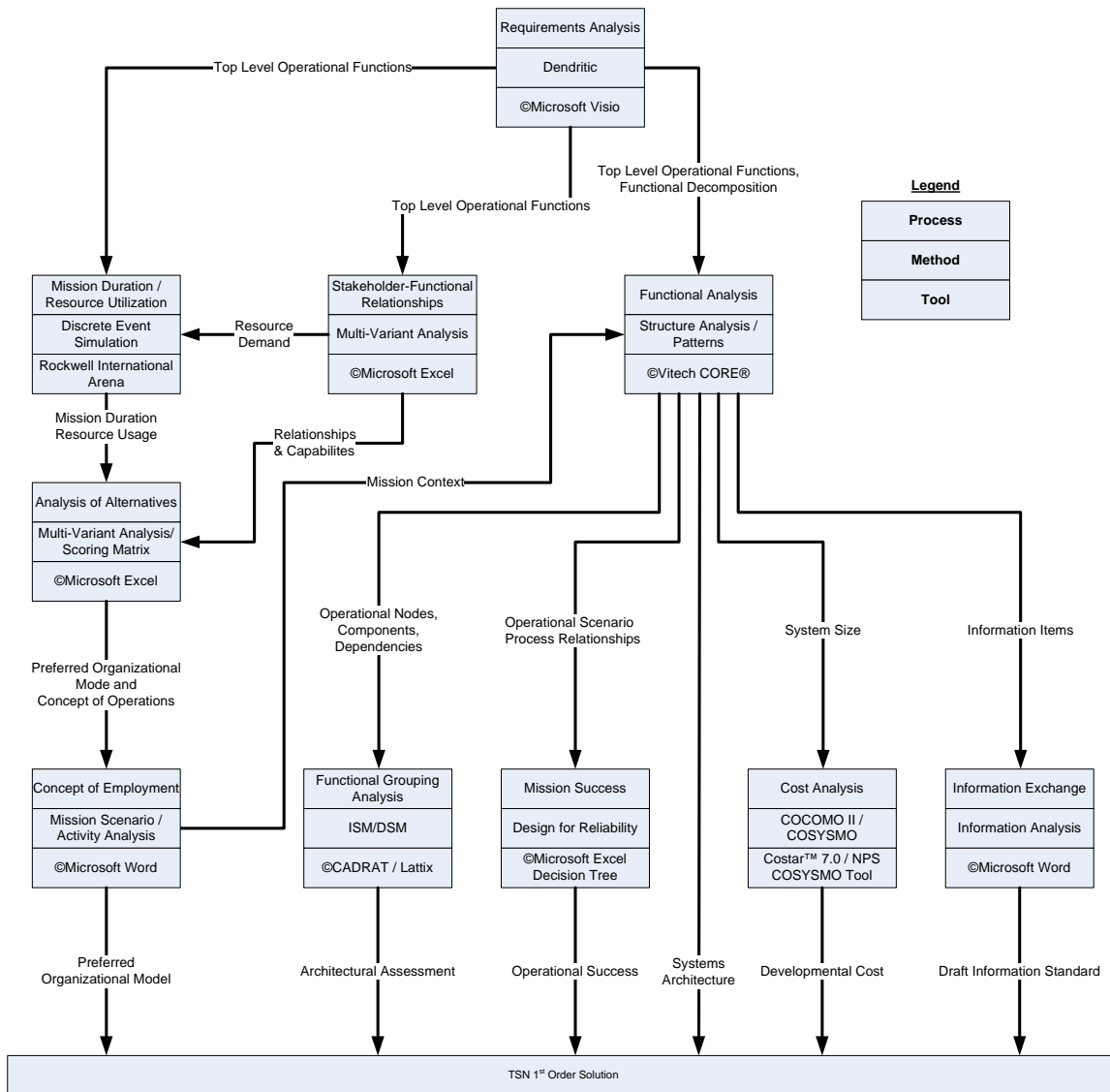

Figure 56. Flow Down of Processes, Methods and Tools Used to Reach Conclusion.

A combination of processes, methods, and tools are used in this study.

D. STUDY RESULTS

Chapter IV declared the committee organizational model as the preferred alternative for TSN. Suggested by the AoA, the committee approach, shown in Figure 57, was favored over the traditional team or group approaches primarily due to political feasibility. The AoA was a weighted normalized matrix that transformed team assessments and data from nine sub-alternatives. Random events stimulated each model

having an average occurrence of 60 hours for transnational threat enforcement, 98 hours for humanitarian aid, and 101 hours for disaster relief/protect environment response. Results from these models included resource usage and mission duration times which were used by the AoA.

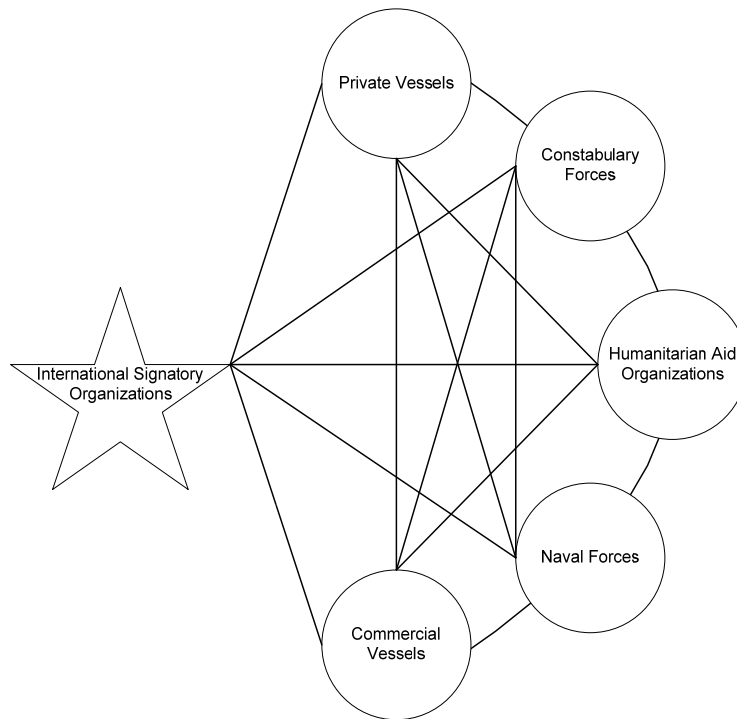

Figure 57. Committee Organizational Model.

The committee model scored the highest average value in the AoA assuming equal weighting of the three TSN missions.

Employing the committee organizational model, three C4I tiers were used to involve stakeholders using backbone, edge and broadcast capabilities. Backbone capabilities include nations' navies, constabulary and intelligence units with the highest access to TSN information and operations. Edge capability includes commercial and humanitarian organizations with access to TSN information and limited operations. Broadcast capabilities include all other stakeholders, e.g., private stakeholders, with the lowest level access to TSN situation awareness information.

TSN C4I was organized into three critical operational functions: Provide Intelligence, Perform Command and Control, and Operate Unit. Traditional operational capability patterns were used for the first two functions. The operational capability

pattern for Provide Intelligence was Task, Process Post and Use. The operational capability pattern for Perform Command and Control was Sense, Assess, Generate, Select, Plan, and Direct. From functional analysis, sub-functions were derived and allocated to the following operational nodes: C2, Intelligence, and Unit. The latter node was further instantiated to navy, constabulary, humanitarian, commercial and private. Between these nodes, needlines and operational information described the dependencies between the nodes.

From the arrangement of operational nodes an operational architecture was developed and assessed with the use of mission success and a structural assessment. Mission success of operational scenarios scored disaster relief/protect environment with a 75 percent likelihood of success, humanitarian aid with a 64 percent likelihood of success, and transnational threat enforcement with a 63 percent likelihood of success. The difference of functions and their arrangement determined separate results. Structural assessment of the operational architecture results yielded acceptable scores: a cluster factor of 1.8, where 1.0 is ideal, and a system stability of 72 percent, where 100 percent is ideal. An additional assessment, the operational test and evaluation plan, developed for the TSN C4I system was provided as a validation approach that can be applied when TSN C4I undergoes operational testing.

An example system architecture was derived from the operational architecture for the purpose of developing a software solution that was portable across heterogeneous environments. System functions were derived and mapped to operational functions with a Department of Defense Architecture Framework (DoDAF) System View Five (SV-5). System sub-functions were derived and allocated to the following system architecture components: Asset Management Computer Software Configuration Item (CSCI), Situation Awareness CSCI, Fusion CSCI, Intelligence CSCI, Mission Planning CSCI, Mission Operations CSCI, Mission Analysis CSCI, Information Release CSCI, and Communications and Network Management Service. Structural assessment of the system architecture results yielded acceptable scores: a cluster factor of 1.5, where 1.0 is ideal, and a system stability of 80 percent, where 100 percent is ideal.

Derived from the operational architecture needlines and operational information, system data items and their interfaces were developed. On this foundation, an information exchange standard was developed for the TSN C4I system. The standard represents essential information elements which pass among TSN stakeholders.

As the final achievement of the study, the TSN C4I architectures evaluated developmental cost. An estimated total for developing the CSCIs to support the TSN C4I system implementing a committee organization was the combination of both systems engineering costs and software engineering costs. With a confidence level of 50 percent for the systems engineering estimate and 80 percent for the software engineering estimate, the total estimate cost was determined to be \$9.68 million assuming a \$60.00 labor rate.

E. RECOMMENDATIONS

This study by no means is the end of establish a TSN solution that can be funded and implemented. Rather, this study, the design-of-the-design, explores the operational and system domain characteristics of TSN finishing with investigating developmental costs and an information exchange standard. The intent of this study, a product of the systems engineering process, serves as the useful basis for follow on engineering efforts. These efforts include, but are not limited to: establishing a full set of stakeholder capabilities and resource entities, sub-system level hardware and software block diagrams, information exchange standard element details, data structure, performance analysis, hardware and software platform cost, as well as suitability analysis and life cycle costs.

VI. LIST OF REFERENCES

- Adamson L. 2008. "IMO Maritime Safety Committee progress board Agenda" downloaded 15 Aug 2009 from http://www.imo.org/About/mainframe.asp?topic_id=1709&doc_id=10644.
- Adkins, A. D., LCDR USN. 2008. "The Global Fleet Station Concept: Meeting Strategic Level Requirements" Master Thesis for U.S. Army Command and General Staff College.
- Anderson M., MAJ, and Zukauskas E, eds. 2008. *Operational Law Handbook*, The Judge Advocate General's Legal Center and School, International and Operational Law Department. http://www.au.af.mil/au/awc/awcgate/law/oplaw_hdbk.pdf.
- The Association of South East Asian Nations. 2008. "ASEAN Emergency Rapid Assessment Team Mission Report, Cyclone Nargis, Myanmar", downloaded 10 June 2009 from <http://www.asean.org/21990.htm>.
- Barrowclough, Anne. 2008. "China sends navy to fight Somali pirates." downloaded 2 August 2009 from <http://www.timesonline.co.uk/tol/news/world/africa/article5398856.ece>.
- Bayne J. PhD, and Paul R. PhD. 2005. "Scale-free Enterprise Command and Control Unified Command Structures", Technical Report for 10th International Command and Control Research and Technology Symposium, Echelon 4 Corporation, Thiensville, Wisconsin.
- Bear, Michael. 2008. "Statistics on Humanitarian Relief" downloaded 25 October 2009 from http://war.change.org/blog/view/statistics_on_humanitarian_relief.
- Bergot, G., Hardy, Y., Marcellus A. 2004. "IDA – Set up of the SafeSeaNet Architecture: Global Implementation Plan, Version 1.0", downloaded on 23 July 2009 from <http://ec.europa.eu/idabc/servlets/Doc?id=1883>.
- Blanchard, Benjamin S, Fabrycky Wolter J. 2006. *Systems Engineering and Analysis*, Upper Saddle River, New Jersey: Pearson Prentice Hall.
- Boehm, B; Abts, C.; Brown, A.W.; Chulani, S.; Clark, B.K.; Horowitz, E.; Madachy, R.; Reifer, D.; Steece, B. 2000. *Software Cost Estimation with COCOMO II*. Upper Saddle River, New Jersey: Prentice Hall.
- Bordo M.D., and Meissner C.M. 2007. "Foreign Capital and Economic Growth in the First Era of Globalization", presented at the Conference on Globalization and Democracy, Princeton University, September 2007.

Bowler M., Jones A., Lebas F. X., Noble J., Osvald G., Plamqvist R., Schylberg L. 2009. "NCOIC Interoperability Framework: NIFTM Solution Description Reference Manual (NSD-RM) Appendix A 1.7 Network Centric Patterns", Technical Report NCOIC-NSFv2NSD-RM-A1.7, Net Centric Operations Industry Consortium (unpublished).

British American Security Information Council. Proliferation Security Initiative.
<http://www.basicint.org/nuclear/counterproliferation/psi.htm>.

Boardman J., Shuuy D. 2009. "Combined Enterprise Regional Information Exchange System (CENTRIXS); Supporting Coalition Warfare World-Wide:", downloaded 28 November 2009 from <http://www.au.af.mil/au/awc/awcgate/ccrp/centrixs.pdf>.

Buede, D. M. 2000. *The Engineering Design of Systems Modeling and Methods*. New York, New York: John Wiley & Sons.

Cline, R. S. 1975. *World Power Assessment: A Calculus of Strategic Drift*, Colorado, Bolder: Westview Press.

Collectè Localisation Satellites. ShipLoc: How it Works.
http://www.shiploc.com/html/how_it_works.html.

Connolly, P. 2006. *Greece and Rome at War*, London, England: Greenhill Books.
Cornell University Law School. International Law: An Overview.
http://topics.law.cornell.edu/wex/International_law.

Cornell University Law School. Admiralty Law: An Overview.
<http://topics.law.cornell.edu/wex/admiralty>.

Cronin P. M. 2009. "The Global Redistribution of Economic Power", *Joint Forces Quarterly* 53 2nd quarter 2009: 8 – 11.

Cummins, C. 2006. "Choke Points; As Threats to Oil Supply Grow, A General Says U.S. Isn't Ready.", downloaded on 2 August 2009 from
<http://secureenergy.org/site/page.php?node=364&id=7>.

Diestel, Reinhard. 2005. *Graduate Text Mathematics, Graph Theory*. Heidelberg: Springer-Verlag.

Douglas, Steven R. 2009. Private conversation at the Naval Surface Warfare Center, Corona Division, 25 November 2009.

Funk R., Sorensen R. 2005. "State Machine Modeling of TPED and TPPU", presented at NDIA 8th Systems Engineering Conference, San Diego.

Hwang J., Schutzer D., Shere K., Vena P., eds. 1982. *Selected Analytical Concepts in Command and Control*, New York, Gordon and Breach Science Publishers.

Hitchins, D. K. 1998. “©CADRAT – A Universal Systems Architecture Tool?” Technical Report in ©CADRAT version 1.2 software documents, ©CADRAT.
Hoivik T. H. 2009. Notes for OA4603 (OT&E Planning Principals), Naval Postgraduate School (unpublished).

Huijer, Keisha. 2005. “Trends in Oil Spills from Tanker Ships 1995 – 2004”, International Tanker Owners Pollution Federation, London England.

International Chamber of Commerce, Commercial Crime Services. IMB Live Piracy Map 2009. http://www.icc-ccs.org/index.php?option=com_fabrik&view=visualization&controller=visualization.goglemap&Itemid=219.

International Chamber of Commerce, Commercial Crime Services. IMB Piracy Reporting Center. http://www.icc-ccs.org/index.php?option=com_content&view=article&id=30&Itemid=12.

International Maritime Organization. List of Conventions. http://www.imo.org/Conventions/mainframe.asp?topic_id=260.

International Maritime Organization. Long Range Identification and Tracking. http://www.imo.org/safety/mainframe.asp?topic_id=905.

Jones, Brent, ed. 2009. “U.S. food aid ship escapes Somali pirate attack.”, downloaded 2 August 2009 from http://www.usatoday.com/news/world/2009-04-14-second-pirateattack_N.htm.

Kapila, S., PhD. 2004. “India Should Not Join Proliferation Security Initiative (PSI)” downloaded 11 July 2009 from <http://www.southasiaanalysis.org/%5Cpapers10%5Cpaper969.html>.

Keegan, J. G., Kelliher, T. P., and Oliver, D.W. 1997. *Engineering Complex Systems with Models and Objects*, New York, New York: McGraw-Hill.

Kennedy, P. 1987. *The Rise and Fall of the Great Powers*, New York: Random House.
Kennedy, Elizabeth and Mohamed, Olad Hassan. 2008. “Somali Pirates Riches Turn Villages Into Boomtowns.”, downloaded 2 August 2009 from http://www.huffingtonpost.com/2008/11/19/somali-pirates-riches-tur_n_144942.html.

Lattix Knowledge Database. <http://kb.lattix.com/node/433>.

Looney, R., Schrady D., and Porch D. 2001. "Economic Impact of Naval Forward Presence: Benefits, Linkage and future Prospects as Modified by Trends in Globalization" Technical Report NPS-NS-02-001, Naval Postgraduate School, Monterey CA.

Madachy, Raymond. 2009. Notes for SE3011 (Engineering Economics and Cost Estimation: COCOMO II Model), Naval Postgraduate School (unpublished).

Marakas, George M. 2003. *Decision Support Systems*, Upper Saddle River, New Jersey: Prentice Hall.

Marshall, Jim Colonel USA, PAO. 2009. "Continuing Promise 2009: United States Southern Command." downloaded 2 August 2009 from <http://www.southcom.mil/appssc/factfiles.php?id=103>.

Marshall, Julie. 2008. "Canada saves lives by extending naval escorts to Somalia." downloaded 9 August 2009 from <http://www.wfp.org/node/134>.

Martoglio, C. W., RADM USN, and Morgan J. G., ADM USN. 2005. "The 1000-Ship Navy: Global Maritime Network", United States Naval Proceedings 131 11: 14-18.

McConnell, Kathryn. 2009. "Commercial Fleet Owners Ask U.S. Congress for Solutions on Piracy" downloaded 15 April 2009 from <http://www.america.gov/st/peacesec-english/2009/May/20090508142627akllennoccm0.3703119.html>.

Morgan, J. G., ADM USN. 2006. "Maritime Partners The 1,000 Ship Navy Trust is a Competitive Advantage", downloaded 15 April 2009 from http://www.jhuapl.edu/cfgms/presentations/Morgan_IMSS.pdf.

Multilateral Interoperability Programme Data Modeling Working Group. 2009. *The Joint C3 Information Exchange Data Model Overview*, MIP-NATO. http://www.mip-site.org/publicsite/04-Baseline_3.0/JC3IEDM-Joint_C3_Information_Exchange_Data_Model/.

National Research Council (U.S.), Committee on FORCENet Implementation Strategy, ed. 2005. *FORCENet Implementation Strategy*, Washington DC: National Academies Press.

Naval Historical Center. 2008. "U.S. Navy Active Ship force Levels, 1917 - Present", downloaded 8 July 2009 from <http://www.history.navy.mil/branches/org9-4.htm>.

Nyakairu, Frank. 2009. "Aid groups face tough battle against Somali pirates.", downloaded 2 August 2009 from http://www.alertnet.org/db/an_art/55866/2009/03/17-162605-1.htm.

Royal Navy, (2009), “Rise of the Royal Navy 1660-1815” downloaded 7 July 2009
<http://www.royalnavy.mod.uk/history/historical-periods/1660-1815/>.

Rowan, C. 2006. “Globalization: A Short History”, Journal of World History 17 4
December: 458 - 461.

Sakhuja, V. 2007. “Any Asian takers for a 1000 Ship Navy”, downloaded 20 June 2009
from <http://www.opinionasia.org>.

Sage, A. P.1977. *Methodology for Large-Scale Systems*, New York, New York:
McGraw-Hill Book Company.

Scudder, J. L., LCDR USN. (2005). “Can U.S. Led Efforts Reduce Piracy in the Malacca
and Singapore Straits?”, DTIC Report ADA463868, Joint Military Operations
Department, Naval War College RI.

Siegel, Adam B. 2003. “A Sampling of U.S. Naval Humanitarian Operations.”
downloaded 2 August 2009 from
<http://www.history.navy.mil/library/online/humanitarian.htm>.

Stewart, D. V. 1981. “The Design Structure System – A Method for Managing the
Design of Complex Systems”, IEEE Transactions on Engineering Management, Vol.
28/3, 71-74.

Stutz, Douglas H. 2005. “Lincoln Sailors Design Potable Water System, Deliver Water to
Banda Aceh.” downloaded 2 August 2009 from
http://www.navy.mil/search/display.asp?story_id=16642.

Swartz, Peter. M., Duggan K. 2008. “U.S. Navy Capstone Strategies Visions & Concepts
(1970 – 2009)”, downloaded 11 April 2009 from
<http://www.cna.org/documents/D0019819.A1.pdf>.

Valerdi, Ricardo, PhD. 2006. Systems Engineering Cost Estimation with COSYSMO.
Manuscript, Massachusetts Institute of Technology, Boston (Unpublished).

United Nations. 1982. *United Nations Convention On The Law Of The Sea*, United
Nations. http://www.un.org/Depts/los/convention_agreements/texts/unclos/unclos_e.pdf.
U.S. Coast Guard. AIS Overview. <http://www.navcen.uscg.gov/enav/ais/>.

U.S. Department of Defense. 2005. “DoDD 3000.05, Military Support for Stability,
Security, Transition, and Reconstruction (SSTR) Operations”, 28 November 2005.

U.S. Department of Defense. 2009. “The Department of Defense Architecture
Framework (DODAF) Version 2.0”, 28 May 2009.

U.S. Department of Justice. 2009. "Global Justice Information Sharing Initiative", downloaded on 24 July 2009 from <http://www.it.ojp.gov/default.aspx?area=globalJustice&page=1019>.

U.S. Department of Navy. 2007. "A Cooperative Strategy for 21st Century Seapower", downloaded 14 July 2009 from <http://www.navy.mil/maritime/MaritimeStrategy.pdf>.

U.S. Department of Defense Chief Information Officer (DON CIO). 2007. "Department of Defense Global Information Grid Architectural Vision; Vision for a Net-Centric, Service-Oriented DoD Enterprise", downloaded August 16, 2009 from <http://www.defenselink.mil/cio-nii/docs/GIGArchVision.pdf>.

U.S. Department of Homeland Security. 2005. "National Strategy to Achieve Maritime Domain Awareness for the National Strategy for Maritime Security" downloaded August 16, 2009 from http://www.dhs.gov/xlibrary/assets/HSPD_MDAPlan.pdf.

U.S. Department of Navy, Chief Information Officer (DON CIO). 2009. "Maritime Domain Awareness Architecture Management Hub Plan", downloaded 10 April 2009 from <http://www.doncio.navy.mil/Download.aspx?AttachID=876>.

U.S. Department of State. 2005. "International Outreach and Coordination Strategy for the National Strategy for Maritime Security" downloaded 12 July 2009 from http://www.dhs.gov/xlibrary/assets/HSPD_IOCPlan.pdf.

U.S. Department of State. 2007. "Strategic Plan Fiscal Year 2007-2012", downloaded 24 April 2009 <http://www.state.gov/documents/organization/86291.pdf>.

U.S. Department of State. 2009. "Proliferation Security Initiative." downloaded 11 July 2009 from <http://www.state.gov/t/isc/c10390.htm/>.

U.S. Joint Forces Command. 2006. Military Support to Stabilization, Security, Transition, and Reconstruction Operations Joint Operating Concepts version 2, USJFCOM. http://www.dtic.mil/futurejointwarfare/concepts/sstro_joc_v20.doc.

Woodson, G. J., USAR. 2007. "Global Maritime Partnership (GMP) Concept Paper" downloaded 15 April 2009 from <http://www.sagecenter.net>.

Ware, James J. Captain, USN. 2009. "Comfort's Recent Missions.", downloaded 2 August 2009 from <http://www.med.navy.mil/sites/usnscomfort/Pages/MSCRecentMissions.aspx>.

Yassine, A. A. 2004. "An Introduction to Modeling and Analyzing Complex Product Development Process Using the Design Structure Matrix (DSM) Method", Lattix Software Company, Andover MI.

VII. PIRACY ANALYSIS

TOTAL SOMALI COASTAL STATISTICS (GULF OF ADEN AND INDIAN OCEAN, CY2009)

REPORT	DATE	LOCAL TIME	LATITUDE			LONGITUDE			VESSEL	BODY OF WATER	NEAREST COUNTRY	# OF ATTACKING SHIPS	STATUS	SUCCESSFUL?	TASK FORCE ASSIST		
			H	M	S	H	M	S									
2009/001	1-Jan	3:37	13	5	0	N	47	3	0	E	TANKER	G OF ADEN	YEMEN	2	FIRED UPON	NO	YES
2009/003	1-Jan	7:47	13	55	0	N	47	58	0	E	CARGO	G OF ADEN	YEMEN	1	HIJACKED	YES	NO
2009/002	1-Jan	12:30	13	53	0	N	49	29	0	E	BULK	G OF ADEN	YEMEN	1	FIRED UPON	NO	NO
2009/012	1-Jan	7:30	14	21	0	N	50	34	0	E	BULK	G OF ADEN	YEMEN	1	ATTEMPT	NO	YES
2009/013	1-Jan	14:05	14	47	0	N	51	47	0	E	BULK	G OF ADEN	YEMEN	2	FIRED UPON	NO	YES
2009/005	2-Jan	4:27	13	51	0	N	47	32	5	E	TANKER	G OF ADEN	YEMEN	3	FIRED UPON	NO	NO
2009/020	2-Jan	11:20	-	-	-	N	-	-	-	E	CARGO	G OF ADEN	YEMEN	1	FIRED UPON	NO	YES
2009/004	2-Jan	8:07	13	42	0	N	50	39	0	E	TANKER	G OF ADEN	YEMEN	3	FIRED UPON	NO	YES
2009/009	3-Jan	5:00	12	55	0	N	45	50	0	E	TANKER	G OF ADEN	YEMEN	4	HIJACKED	YES	NO
2009/016	4-Jan	3:35	13	24	0	N	48	55	0	E	TANKER	G OF ADEN	YEMEN	1	FIRED UPON	NO	YES
2009/007	4-Jan	5:40	13	3	0	N	48	42	5	E	CARGO	G OF ADEN	YEMEN	1	FIRED UPON	NO	YES
2009/024	8-Jan	0:30	1	44	58	S	41	29	7	E	FISHING	INDIAN O	KENYA	1	BOARDED	YES	NO
2009/014	13-Jan	8:10	12	24	5	N	44	57	7	E	BULK	G OF ADEN	YEMEN	1	FIRED UPON	NO	YES
2009/022	14-Jan	12:45	13	2	18	N	46	41	6	E	TANKER	G OF ADEN	YEMEN	2	ATTEMPT	NO	YES
2009/032	29-Jan	6:20	12	27	7	N	44	50	5	E	BULK	G OF ADEN	YEMEN	6	ATTEMPT	NO	YES
2009/030	29-Jan	3:40	14	50	0	N	49	58	0	E	LPG	G OF ADEN	YEMEN	1	HIJACKED	YES	NO
2009/011	1-Feb	4:40	13	53	0	N	47	32	0	E	CARGO	G OF ADEN	YEMEN	2	ATTEMPT	NO	YES
2009/036	11-Feb	6:30	10	39	0	N	55	54	0	E	BULK	INDIAN O	SOMALIA	1	FIRED UPON	NO	NO
2009/038	11-Feb	11:30	12	59	0	N	48	56	0	E	TANKER	G OF ADEN	YEMEN	1	ATTEMPT	NO	YES
2009/040	12-Feb	14:30	13	9	0	N	49	9	0	E	BULK	G OF ADEN	YEMEN	1	FIRED UPON	NO	YES
2009/046	12-Feb	0:01	12	44	0	N	47	46	2	E	TANKER	G OF ADEN	YEMEN	1	FIRED UPON	NO	YES
2009/049	19-Feb	16:30	4	33	0	N	52	55	0	E	FISHING	INDIAN O	SOMALIA	1	FIRED UPON	NO	NO
2009/050	21-Feb	19:00	14	31	1	N	53	43	1	E	CARGO	G OF ADEN	YEMEN	1	ATTEMPT	NO	NO
2009/051	22-Feb	4:00	12	33	98	N	47	1	32	E	BULK	G OF ADEN	YEMEN	1	HIJACKED	YES	NO
2009/057	25-Feb	10:30	13	8	4	N	49	9	5	E	BULK	G OF ADEN	YEMEN	1	FIRED UPON	NO	NO
2009/053	26-Feb	6:00	12	11	0	N	43	31	0	E	BULK	G OF ADEN	YEMEN	3	ATTEMPT	NO	NO
2009/058	2-Mar	6:49	12	9	0	N	45	33	0	E	TANKER	G OF ADEN	YEMEN	1	FIRED UPON	NO	NO
2009/059	3-Mar	6:12	13	2	0	N	48	43	0	E	CARGO	G OF ADEN	YEMEN	1	FIRED UPON	NO	YES
2009/061	4-Mar	7:35	12	17	9	N	44	9	9	E	BULK	G OF ADEN	YEMEN	5	ATTEMPT	NO	NO
2009/062	5-Mar	3:45	7	56	0	N	65	28	0	E	CARGO	INDIAN O	SOMALIA	1	ATTEMPT	NO	NO
2009/064	9-Mar	18:00	8	2	0	N	58	45	0	E	BULK	INDIAN O	SOMALIA	1	FIRED UPON	NO	NO
2009/065	10-Mar	5:00	8	6	0	N	59	11	0	E	BULK	INDIAN O	SOMALIA	1	FIRED UPON	NO	NO
2009/069	12-Mar	22:20	4	2	0	S	46	33	0	E	CARGO	INDIAN O	SOMALIA	2	FIRED UPON	NO	NO
2009/068	11-Mar	5:20	13	16	5	N	49	44	3	E	BULK	G OF ADEN	YEMEN	1	ATTEMPT	NO	YES
2009/070	13-Mar	7:13	7	11	0	N	58	50	0	E	FISHING	INDIAN O	SOMALIA	1	FIRED UPON	NO	NO
2009/071	14-Mar	6:45	13	43	26	N	49	19	35	E	BULK	G OF ADEN	YEMEN	2	FIRED UPON	NO	YES
2009/078	20-Mar	10:02	7	51	8	S	45	4	5	E	CARGO	INDIAN O	SOMALIA	1	ATTEMPT	NO	NO

Table 25. Gulf of Aden Piracy Analysis January 2009 to March 2009 (International Chamber of Commerce, Commercial Crime Services, IMB Live Piracy Map).

Piracy data over first three months of 2009 show a inter-arrival time of 60 days.

THIS PAGE INTENTIONALLY LEFT BLANK

VIII. APPENDIX OPERATIONAL DOMAIN SUPPORTING MATERIAL

Response Functions	Delay Type	Minimum	Value	Maximum	(Units)
Sense Environment	Triangular	10.39	21.89	30	Minutes
Assess Intentions and Capabilities	Triangular	1.18	2.89	4	Hours
Generate COAs	Triangular	5.62	23.24	30	Minutes
Select Alternatives	Triangular	0.79	1.25	1.5	Hours
Plan Details	Triangular	9.43	16.37	24	Hours
Direct Response	Triangular	1.11	2.61	3	Hours
Intelligence (Gather) Functions					
Task Data Collections	Triangular	16.02	45.06	60	Minutes
Process Data	Triangular	16.02	45.06	60	Minutes
Post Intelligence Products	Triangular	5.48	19.88	20	Minutes
Use Intelligence Products	Triangular	1.06	2.5	2.5	Minutes
Situational Awareness Functions					
Sense Environment	Triangular	6.11	9.3	10	Minutes
Process Data	Triangular	0.58	1	1	Minutes
Post Intelligence Products	Triangular	0.79	1	1	Minutes
Use Intelligence Products	Triangular	0.59	1.55	2	Minutes
Intelligence (Posting) Functions					
Task Data Collections	Triangular	18.5	51.04	60	Minutes
Process Data	Triangular	21.23	54.1	60	Minutes
Post Intelligence Products	Triangular	9.35	20	20	Minutes
Use Intelligence Products	Triangular	1.3	2.5	2.5	Minutes

Table 26. Team Organization Process Times for Transnational Threat Enforcement, Humanitarian Aid, and Disaster Relief/Protect Environment.

Team process times are adjusted based on stakeholders assignment to complete a process.

Response Functions	Delay Type	Minimum	Mode	Maximum	(Units)
Sense Environment	Triangular	6.82	13.59	15	Minutes
Assess Intentions and Capabilities	Triangular	1.05	2.51	3.07	Hours
Generate COAs	Triangular	5	15	30	Minutes
Select Alternatives	Triangular	0.75	1	1.5	Hours
Plan Details	Triangular	8	12	24	Hours
Direct Response	Triangular	1.3	2.75	3	Hours
Intelligence (Gather) Functions					
Task Data Collections	Triangular	16.02	45.06	60	Minutes
Process Data	Triangular	16.02	45.06	60	Minutes
Post Intelligence Products	Triangular	5.48	19.88	20	Minutes
Use Intelligence Products	Triangular	1.3	2.5	2.5	Minutes
Situational Awareness Functions					
Sense Environment	Triangular	3.17	4.44	4.5	Minutes
Process Data	Triangular	0.52	1	1	Minutes
Post Intelligence Products	Triangular	0.52	1	1	Minutes
Use Intelligence Products	Triangular	0.65	1.7	2	Minutes
Intelligence (Posting) Functions					
Task Data Collections	Triangular	16.02	45.06	60	Minutes
Process Data	Triangular	14.19	39.13	46	Minutes
Post Intelligence Products	Triangular	5.97	15.34	15.34	Minutes
Use Intelligence Products	Triangular	1.45	2.5	2.5	Minutes

Table 27. Committee Organization Process Times for Transnational Threat Enforcement.
Committee process times are adjusted based on stakeholders assignment to complete a process.

Response Functions	Delay Type	Minimum	Mode	Maximum	(Units)
Sense Environment	Triangular	12.4	26.54	30	Minutes
Assess Intentions and Capabilities	Triangular	1.74	3.77	4	Hours
Generate COAs	Triangular	7.13	26.26	30	Minutes
Select Alternatives	Triangular	0.81	1.35	1.5	Hours
Plan Details	Triangular	9.68	19.45	24	Hours
Direct Response	Triangular	1.3	2.75	3	Hours
Intelligence (Gather) Functions					
Task Data Collections	Triangular	24.42	54.87	60	Minutes
Process Data	Triangular	18.5	51.04	60	Minutes
Post Intelligence Products	Triangular	7.79	20	20	Minutes
Use Intelligence Products	Triangular	1.54	2.5	2.5	Minutes
Situational Awareness Functions					
Sense Environment	Triangular	7.03	9.85	10	Minutes
Process Data	Triangular	0.52	1	1	Minutes
Post Intelligence Products	Triangular	0.52	1	1	Minutes
Use Intelligence Products	Triangular	0.77	1.85	2	Minutes
Intelligence (Posting) Functions					
Task Data Collections	Triangular	26.08	56.75	60	Minutes
Process Data	Triangular	18.5	51.04	60	Minutes
Post Intelligence Products	Triangular	7.79	20	20	Minutes
Use Intelligence Products	Triangular	1.63	2.5	2.5	Minutes

Table 28. Group Organization Process Times for Transnational Threat Enforcement.
Group process times are adjusted based on stakeholders assignment to complete a process.

Response Functions	Delay Type	Minimum	Mode	Maximum	(Units)
Sense Environment	Triangular	6.82	13.59	15	Minutes
Assess Intentions and Capabilities	Triangular	1.05	2.51	3.07	Hours
Generate COAs	Triangular	5.62	23.24	30	Minutes
Select Alternatives	Triangular	0.75	1	1.5	Hours
Plan Details	Triangular	8	12	24	Hours
Direct Response	Triangular	1.43	2.86	3	Hours
Intelligence (Gather) Functions					
Task Data Collections	Triangular	16.02	45.06	60	Minutes
Process Data	Triangular	14.19	39.13	46	Minutes
Post Intelligence Products	Triangular	5.97	15.34	15.34	Minutes
Use Intelligence Products	Triangular	1.45	2.5	2.5	Minutes
Situational Awareness Functions					
Sense Environment	Triangular	3.17	4.44	4.5	Minutes
Process Data	Triangular	0.52	1	1	Minutes
Post Intelligence Products	Triangular	0.52	1	1	Minutes
Use Intelligence Products	Triangular	0.65	1.7	2	Minutes
Intelligence (Posting) Functions					
Task Data Collections	Triangular	16.02	45.06	60	Minutes
Process Data	Triangular	14.18	39.13	46	Minutes
Post Intelligence Products	Triangular	5.97	15.34	15.34	Minutes
Use Intelligence Products	Triangular	1.45	2.5	2.5	Minutes

Table 29. Committee Organization Process Times for Humanitarian Aid and Disaster Relief/Protect Environment Response.

Committee process times are adjusted based on stakeholders assignment to complete a process.

Response Functions	Delay Type	Minimum	Mode	Maximum	(Units)
Sense Environment	Triangular	12.4	26.54	30	Minutes
Assess Intentions and Capabilities	Triangular	1.74	3.77	4	Hours
Generate COAs	Triangular	8.79	27.66	30	Minutes
Select Alternatives	Triangular	0.86	1.42	1.5	Hours
Plan Details	Triangular	10.99	19.88	24	Hours
Direct Response	Triangular	1.43	2.86	3	Hours
Intelligence (Gather) Functions					
Task Data Collections	Triangular	26.08	56.75	60	Minutes
Process Data	Triangular	18.5	51.04	60	Minutes
Post Intelligence Products	Triangular	7.79	20	20	Minutes
Use Intelligence Products	Triangular	1.63	2.5	2.5	Minutes
Situational Awareness Functions					
Sense Environment	Triangular	7.03	9.85	10	Minutes
Process Data	Triangular	0.52	1	1	Minutes
Post Intelligence Products	Triangular	0.52	1	1	Minutes
Use Intelligence Products	Triangular	0.77	1.85	2	Minutes
Intelligence (Posting) Functions					
Task Data Collections	Triangular	26.08	56.75	60	Minutes
Process Data	Triangular	18.5	51.04	60	Minutes
Post Intelligence Products	Triangular	7.79	20	20	Minutes
Use Intelligence Products	Triangular	1.63	2.5	2.5	Minutes

Table 30. Group Organization Process Times for Humanitarian Aid and Disaster Relief/Protect Environment Response.

Group process times are adjusted based on stakeholders assignment to complete a process.

Needline	Operational Information Element	Information Source	Information Destination
Constabulary Unit Receive PNT	Position and Timing Description: Satellite navigation signals from one of four global satellite navigation systems. Accuracy: Commercial SATNAV quality	External Nodes <i>Generate Position and Time</i>	External Nodes <i>NGO Receive Position and Timing</i> External Nodes <i>Operate AIS</i> External Nodes <i>Operate Environment Monitoring</i> External Nodes <i>Operate GMDSS</i> External Nodes <i>Operate LRIT</i> External Nodes <i>Operate NCA</i> External Nodes <i>Operate Port</i> External Nodes <i>Operate PRC</i> Unit.Constabulary <i>Process Data</i> Unit.Constabulary <i>Process Unit Information</i> Unit.Constabulary <i>Provide Unit Sensed Contacts</i> Unit.Constabulary <i>Sense Environment</i>
Constabulary Unit Send/Receive C2	Environmental Alert TSN Node Description: Vessel report of the environmental status, alert or incident. Accuracy: Correct information	Unit.Constabulary <i>Inform TSN Node</i>	C2.TSN <i>Detect Objects and Conditions</i> C2.TSN

Needline	Operational Information Element	Information Source	Information Destination
			<i>Generate COAs</i>
	Sensor Reports Accuracy: Commercial SATNAV quality and relevant	Unit.Constabulary <i>Provide Unit Sensed Contacts</i> Unit.Constabulary <i>Release Image</i>	C2.TSN <i>Collect Imagery</i> C2.TSN <i>Sense Environment</i>
Constabulary Unit Send/Receive Coordination Humanitarian	Constabulary Tasking Plan Description: Allows the CG center to task CG units and interrogate commercial and private vessels. Accuracy: Correct Tactical Unit	Unit.Constabulary <i>Perform Unit Coordination</i>	Unit.Constabulary <i>Process COA</i>
Constabulary Unit Send/Receive Coordination Maritime Commerical	Constabulary Tasking Plan Description: Allows the CG center to task CG units and interrogate commercial and private vessels. Accuracy: Correct Tactical Unit	Unit.Constabulary <i>Perform Unit Coordination</i>	Unit.Constabulary <i>Process COA</i>
Constabulary Unit Send/Receive Coordination Maritime Private	Constabulary Tasking Plan Description: Allows the CG center to task CG units and interrogate commercial and private vessels. Accuracy: Correct Tactical Unit	Unit.Constabulary <i>Perform Unit Coordination</i>	Unit.Constabulary <i>Process COA</i>
Constabulary Unit Send/Receive Intelligence	Incident Person Description: Incident report or contact report of a person of interest. Message may also be a request for information. Accuracy: Is the report of the intended person.	Unit.Constabulary <i>Process Unit Information</i>	Intelligence.TSN <i>Process Data</i>
	Incident Vessel Description: Incident report or contact report of a vessel of interest. Message may also be a	Unit.Constabulary <i>Assess Intentions and Capabilities</i>	Intelligence.TSN <i>Process Data</i>

Needline	Operational Information Element	Information Source	Information Destination
	request for information. Accuracy: Is the report of the intended person.	Unit.Constabulary <i>Process Unit Information</i>	
	Intelligence Msg Description: Intelligence message of HUMINT, SIGINT, ELINT, SNOOPY or other means. Message may also be a request for information. Accuracy: Commercial SATNAV quality	Unit.Constabulary <i>Process Unit Information</i>	Intelligence.TSN <i>Process Data</i>
	Intelligence Summary Description: Summary of general intelligence (Law Enforcement and Military sources) in the AOR. Accuracy: Commercial SATNAV quality and Analysis provided and relevant	Intelligence.TSN <i>Post Intelligence Products</i> Intelligence.TSN <i>Download Products</i>	Unit.Constabulary <i>Assess Intentions and Capabilities</i> Unit.Constabulary <i>Process Unit Information</i> Unit.Constabulary <i>Sense Environment</i>
	Operational Picture Description: TSN produced common operational geospatial Awareness from fused sources of information. The information may be provided in different layers where each layer provides different information depending of level of service. Level of service is dependent of role: Authority, Commercial, Private. Accuracy: Commercial SATNAV quality and relevant	Intelligence.TSN <i>Post Intelligence Products</i> Intelligence.TSN <i>Download Operatonal Picture</i>	Unit.Constabulary <i>Assess Intentions and Capabilities</i> Unit.Constabulary <i>Process Unit Information</i>
	Request Intelligence Summary Accuracy: Commercial SATNAV quality and relevant	Unit.Constabulary <i>Process Unit Information</i>	Intelligence.TSN <i>Release Intelligence Summary</i>
	Request Operational Picture Accuracy: Commercial SATNAV quality and	Unit.Constabulary <i>Request Operational</i>	Intelligence.TSN <i>Release Operational Picture</i>

Needline	Operational Information Element	Information Source	Information Destination
	relevant	<i>Picture</i>	
	Unit Intelligence Tasking Accuracy: Correct Tactical Unit	Intelligence.TSN <i>Task Data Collection</i>	Unit.Constabulary <i>Process Unit Information</i>
Constabulary Unit Send/Receive Reachback	Environment Alert Land Node Description: Vessel report of the environmental status, alert or incident. Accuracy: Correct information	Unit.Constabulary <i>Inform Land Node</i>	External Nodes <i>Operate Communication</i> External Nodes <i>Receive Environment Event</i>
Humanitarian Unit Receive PNT	Position and Timing Description: Satellite navigation signals from one of four global satellite navigation systems. Accuracy: Commercial SATNAV quality	External Nodes <i>Generate Position and Time</i>	External Nodes <i>NGO Receive Position and Timing</i> External Nodes <i>Operate AIS</i> External Nodes <i>Operate Environment Monitoring</i> External Nodes <i>Operate GMDSS</i> External Nodes <i>Operate LRIT</i> External Nodes <i>Operate NCA</i> External Nodes <i>Operate Port</i> External Nodes <i>Operate PRC</i> Unit.Humanitarian <i>Process Data</i> Unit.Humanitarian <i>Process Unit Information</i>

Needline	Operational Information Element	Information Source	Information Destination
			Unit.Humanitarian <i>Provide Unit Sensed Contacts</i> Unit.Humanitarian <i>Sense Environment</i>
Humanitarian Unit Send/Receive C2	Sensor Reports Accuracy: Commercial SATNAV quality and relevant	Unit.Humanitarian <i>Provide Unit Sensed Contacts</i> Unit.Humanitarian <i>Release Image</i>	C2.TSN <i>Collect Imagery</i> C2.TSN <i>Sense Environment</i>
Humanitarian Unit Send/Receive Intelligence	Operational Picture Description: TSN produced common operational geospatial Awareness from fused sources of information. The information may be provided in different layers where each layer provides different information depending of level of service. Level of service is dependent of role: Authority, Commercial, Private. Accuracy: Commercial SATNAV quality and relevant	Intelligence.TSN <i>Post Intelligence Products</i> Intelligence.TSN <i>Download Operatonal Picture</i>	Unit.Humanitarian <i>Assess Intentions and Capabilities</i> Unit.Humanitarian <i>Process Unit Information</i>
	Request Operational Picture Accuracy: Commercial SATNAV quality and relevant	Unit.Humanitarian <i>Request Operational Picture</i>	Intelligence.TSN <i>Release Operational Picture</i>
Intelligence Send/Receive Reachback	Center AIS Summary Description: Composite tracks and AIS information with vessel static voyage and dynamic information. Accuracy: Commercial SATNAV quality and relevant	External Nodes <i>Operate AIS</i>	Intelligence.TSN <i>Process Data</i>
	Center LRIT Summary	External Nodes	External Nodes

Needline	Operational Information Element	Information Source	Information Destination
	Description: Composite tracks and LRIT information vessel static voyage and dynamic information. Accuracy: Commercial SATNAV quality	<i>Operate LRIT</i>	<i>Operate Commercial Enterprise</i> Intelligence.TSN <i>Process Data</i>
	Environment Summary Description: Summary of the environmental status, alerts and incidents. Accuracy: Commercial SATNAV quality and relevant	External Nodes <i>Operate Environment Monitoring</i>	External Nodes <i>Operate NCA</i> External Nodes <i>Operate Port</i> Intelligence.TSN <i>Process Data</i>
	Operational Picture Description: TSN produced common operational geospatial Awareness from fused sources of information. The information may be provided in different layers where each layer provides different information depending of level of service. Level of service is dependent of role: Authority, Commercial, Private. Accuracy: Commercial SATNAV quality and relevant	Intelligence.TSN <i>Post Intelligence Products</i> Intelligence.TSN <i>Download Operatonal Picture</i>	Intelligence.TSN <i>Assess Intentions and Capabilities</i> External Nodes <i>NGO Process Operational Picture</i> External Nodes <i>Operate Commercial Enterprise</i> External Nodes <i>Operate NCA</i> External Nodes <i>Operate NGO</i> External Nodes <i>Operate Port</i> External Nodes <i>PRC Receive TSN Operational Picture</i> Intelligence.TSN <i>Process Unit Information</i>
	PRC Summary Description: Composite tracks and PRC	External Nodes <i>Operate PRC</i>	Intelligence.TSN <i>Process Data</i>

Needline	Operational Information Element	Information Source	Information Destination
	information Accuracy: Commercial SATNAV quality and relevant		
	Search & Rescue Summary Description: Summary of search and rescue events with status information. Accuracy: Commercial SATNAV quality and relevant	External Nodes <i>Operate GMDSS</i>	Intelligence.TSN <i>Process Data</i>
	Security Alert Summary Description: Summary of maritime domain security events with status information. Accuracy: Commercial SATNAV quality and relevant	External Nodes <i>Operate Maritime Security</i>	External Nodes <i>Operate PRC</i> Intelligence.TSN <i>Process Data</i>
Maritime Commercial Receive PNT	Position and Timing Description: Satellite navigation signals from one of four global satellite navigation systems. Accuracy: Commercial SATNAV quality	External Nodes <i>Generate Position and Time</i>	External Nodes <i>NGO Receive Position and Timing</i> External Nodes <i>Operate AIS</i> External Nodes <i>Operate Environment Monitoring</i> External Nodes <i>Operate GMDSS</i> External Nodes <i>Operate LRIT</i> External Nodes <i>Operate NCA</i> External Nodes <i>Operate Port</i> External Nodes

Needline	Operational Information Element	Information Source	Information Destination
			<p><i>Operate PRC</i> Unit.Maritime Commercial</p> <p><i>Process Data</i> Unit.Maritime Commercial</p> <p><i>Process Unit Information</i> Unit.Maritime Commercial</p> <p><i>Provide Unit Sensed Contacts</i> Unit.Maritime Commercial</p> <p><i>Sense Environment</i></p>
Maritime Commercial Send Receive Intelligence	<p>Operational Picture</p> <p>Description: TSN produced common operational geospatial Awareness from fused sources of information. The information may be provided in different layers where each layer provides different information depending of level of service. Level of service is dependent of role: Authority, Commercial, Private.</p> <p>Accuracy: Commercial SATNAV quality and relevant</p>	<p>Intelligence.TSN</p> <p><i>Post Intelligence Products</i></p> <p>Intelligence.TSN</p> <p><i>Download Operatonal Picture</i></p>	<p>Unit.Commercial</p> <p><i>Assess Intentions and Capabilities</i></p> <p>Unit.Commercial</p> <p><i>Process Unit Information</i></p>
	<p>Request Operational Picture</p> <p>Accuracy: Commercial SATNAV quality and relevant</p>	<p>Unit.Commercial</p> <p><i>Request Operational Picture</i></p>	<p>Intelligence.TSN</p> <p><i>Release Operational Picture</i></p>
Maritime Commercial Send/Receive C2	<p>Environmental Alert TSN Node</p> <p>Description: Vessel report of the environmental status, alert or incident.</p> <p>Accuracy: Correct information</p>	<p>Unit.Commercial</p> <p><i>Inform TSN Node</i></p>	<p>C2.TSN</p> <p><i>Detect Objects and Conditions</i></p> <p>C2.TSN</p> <p><i>Generate COAs</i></p>
	<p>Sensor Reports</p> <p>Accuracy: Commercial SATNAV quality and relevant</p>	<p>Unit.Commercial</p> <p><i>Provide Unit Sensed Contacts</i></p>	<p>C2.TSN</p> <p><i>Collect Imagery</i></p> <p>C2.TSN</p>

Needline	Operational Information Element	Information Source	Information Destination
		Unit.Commercial <i>Release Image</i>	<i>Sense Environment</i>
Maritime Commercial Send/Receive Reachback	Environment Alert Land Node Description: Vessel report of the environmental status, alert or incident. Accuracy: Correct information	Unit.Commercial <i>Inform Land Node</i>	External Nodes <i>Operate Communication</i> External Nodes <i>Receive Environment Event</i>
	Planned Movement Description: Coordination of a vessel intentions with the PRC. Accuracy: Correct Tactical Unit	Unit.Maritime Commercial <i>Provide Unit Mission Information</i>	External Nodes <i>Operate PRC</i>
	PRC Tasking Plan Description: Allows the PRC center to request assistance from military, constabulary, commercial and private vessels. Accuracy: Commercial SATNAV quality	External Nodes <i>Operate PRC</i>	Unit.Commercial <i>Process COA</i>
	Search & Rescue Msg Description: Search and rescue message sent from vessel. Accuracy: Commercial SATNAV quality and relevant	Unit.Commercial <i>Provide Unit Mission Information</i>	External Nodes <i>Operate GMDSS</i>
	Security Incident Description: Security incident from a vessel. Accuracy: Commercial SATNAV quality	Unit.Commercial <i>Provide Unit Mission Information</i>	External Nodes <i>Operate Maritime Security</i>
Maritime Private Receive PNT	Position and Timing Description: Satellite navigation signals from one of four global satellite navigation systems. Accuracy: Commercial SATNAV quality	External Nodes <i>Generate Position and Time</i>	External Nodes <i>NGO Receive Position and Timing</i> External Nodes <i>Operate AIS</i> External Nodes

Needline	Operational Information Element	Information Source	Information Destination
			<i>Operate Environment Monitoring</i> External Nodes <i>Operate GMDSS</i> External Nodes <i>Operate LRIT</i> External Nodes <i>Operate NCA</i> External Nodes <i>Operate Port</i> External Nodes <i>Operate PRC</i> Unit.Private <i>Process Data</i> Unit.Private <i>Process Unit Information</i> Unit.Private <i>Provide Unit Sensed Contacts</i> Unit.Private <i>Sense Environment</i>
Maritime Private Send/Receive C2	Environmental Alert TSN Node Description: Vessel report of the environmental status, alert or incident. Accuracy: Correct information	Unit.Private <i>Inform TSN Node</i>	C2.TSN <i>Detect Objects and Conditions</i> C2.TSN <i>Generate COAs</i>
	Sensor Reports Accuracy: Commercial SATNAV quality and relevant	Unit.Private <i>Provide Unit Sensed Contacts</i> Unit.Private <i>Release Image</i>	C2.TSN <i>Collect Imagery</i> C2.TSN <i>Sense Environment</i>

Needline	Operational Information Element	Information Source	Information Destination
Maritime Private Send/Receive Intelligence	Operational Picture Description: TSN produced common operational geospatial Awareness from fused sources of information. The information may be provided in different layers where each layer provides different information depending of level of service. Level of service is dependent of role: Authority, Commercial, Private. Accuracy: Commercial SATNAV quality and relevant	Intelligence.TSN <i>Post Intelligence Products</i> Intelligence.TSN <i>Download Operatonal Picture</i>	Unit.Private <i>Assess Intentions and Capabilities</i> Unit.Private <i>Process Unit Information</i>
	Request Operational Picture Accuracy: Commercial SATNAV quality and relevant	Unit.Private <i>Request Operational Picture</i>	Intelligence.TSN <i>Release Operational Picture</i>
Maritime Private Send/Receive Reachback	Environment Alert Land Node Description: Vessel report of the environmental status, alert or incident. Accuracy: Correct information	Unit.Private <i>Inform Land Node</i>	External Nodes <i>Operate Communication</i> External Nodes <i>Receive Environment Event</i>
	Search & Rescue Msg Description: Search and rescue message sent from vessel. Accuracy: Commercial SATNAV quality and relevant	Unit.Private <i>Provide Unit Mission Information</i>	External Nodes <i>Operate GMDSS</i>
Military Unit Receive PNT	Position and Timing Description: Satellite navigation signals from one of four global satellite navigation systems. Accuracy: Commercial SATNAV quality	External Nodes <i>Generate Position and Time</i>	External Nodes <i>NGO Receive Position and Timing</i> External Nodes <i>Operate AIS</i> External Nodes <i>Operate Environment Monitoring</i> External Nodes

Needline	Operational Information Element	Information Source	Information Destination
			<i>Operate GMDSS</i> External Nodes <i>Operate LRIT</i> External Nodes <i>Operate NCA</i> External Nodes <i>Operate Port</i> External Nodes <i>Operate PRC</i> Unit.Navy <i>Process Data</i> Unit.Navy <i>Process Unit Information</i> Unit. Navy <i>Provide Unit Sensed Contacts</i> Unit. Navy <i>Sense Environment</i>
Military Unit Send/Receive C2	Environmental Alert TSN Node Description: Vessel report of the environmental status, alert or incident. Accuracy: Correct information	Unit. Navy <i>Inform TSN Node</i>	C2.TSN <i>Detect Objects and Conditions</i> C2.TSN <i>Generate COAs</i>
	Sensor Reports Accuracy: Commercial SATNAV quality and relevant	Unit. Navy <i>Provide Unit Sensed Contacts</i> Unit. Navy <i>Release Image</i>	C2.TSN <i>Collect Imagery</i> C2.TSN <i>Sense Environment</i>
Military Unit Send/Receive Coordination Humanitarian	Vessel Communications Description: Means for vessels to coordinate	Unit.Humanitarian <i>Coordinate Unit</i>	Unit.Humanitarian

Needline	Operational Information Element	Information Source	Information Destination
	rules of the sea and other matters. Accuracy: Correct Tactical Unit	<i>Operations</i>	<i>Perform Unit Action</i>
Military Unit Send/Receive Coordination Maritime Commercial	Vessel Communications Description: Means for vessels to coordinate rules of the sea and other matters. Accuracy: Correct Tactical Unit	Unit.Commercial <i>Coordinate Unit Operations</i>	Unit.Commercial <i>Perform Unit Action</i>
Military Unit Send/Receive Coordination Maritime Private	Vessel Communications Description: Means for vessels to coordinate rules of the sea and other matters. Accuracy: Correct Tactical Unit	Unit.Private <i>Coordinate Unit Operations</i>	Unit.Private <i>Perform Unit Action</i>
Military Unit Send/Receive Intelligence	Incident Person Description: Incident report or contact report of a person of interest. Message may also be a request for information. Accuracy: Is the report of the intended person.	Unit. Navy <i>Process Unit Information</i>	Intelligence.TSN <i>Process Data</i>
	Incident Vessel Description: Incident report or contact report of a vessel of interest. Message may also be a request for information. Accuracy: Is the report of the intended person.	Unit. Navy <i>Assess Intentions and Capabilities</i> Unit. Navy <i>Process Unit Information</i>	Intelligence.TSN <i>Process Data</i>
	Intelligence Msg Description: Intelligence message of HUMNT, SIGINT, ELINT, SNOOPY or other means. Message may also be a request for information. Accuracy: Commercial SATNAV quality	Unit. Navy <i>Process Unit Information</i>	Intelligence.TSN <i>Process Data</i>
	Intelligence Summary Description: Summary of general intelligence (Law Enforcement and Military sources) in the	Intelligence.TSN <i>Post Intelligence Products</i>	Unit. Navy <i>Assess Intentions and Capabilities</i>

Needline	Operational Information Element	Information Source	Information Destination
	AOR. Accuracy: Commercial SATNAV quality and Analysis provided and relevant	Intelligence.TSN <i>Download Products</i>	Unit. Navy <i>Process Unit Information</i> Unit. Navy <i>Sense Environment</i>
	Operational Picture Description: TSN produced common operational geospatial Awareness from fused sources of information. The information may be provided in different layers where each layer provides different information depending of level of service. Level of service is dependent of role: Authority, Commercial, Private. Accuracy: Commercial SATNAV quality and relevant	Intelligence.TSN <i>Post Intelligence Products</i> Intelligence.TSN <i>Download Operatonal Picture</i>	Unit. Navy <i>Assess Intentions and Capabilities</i> Unit. Navy <i>Process Unit Information</i>
	Request Intelligence Summary Accuracy: Commercial SATNAV quality and relevant	Unit. Navy <i>Process Unit Information</i>	Intelligence.TSN <i>Release Intelligence Summary</i>
	Request Operational Picture Accuracy: Commercial SATNAV quality and relevant	Unit. Navy <i>Request Operational Picture</i>	Intelligence.TSN <i>Release Operational Picture</i>
	Unit Intelligence Tasking Accuracy: Correct Tactical Unit	Intelligence.TSN <i>Task Data Collection</i>	Unit. Navy <i>Process Unit Information</i>
Military Unit Send/Receive Reachback	Environment Alert Land Node Description: Vessel report of the environmental status, alert or incident. Accuracy: Correct information	Unit.Navy <i>Inform Land Node</i>	External Nodes <i>Operate Communication</i> External Nodes <i>Receive Environment Event</i>
	Planned Movement Description: Coordination of a vessel intentions with the PRC.	Unit. Navy <i>Provide Unit Mission Information</i>	External Nodes <i>Operate PRC</i>

Needline	Operational Information Element	Information Source	Information Destination
	Accuracy: Correct Tactical Unit		
	PRC Tasking Plan Description: Allows the PRC center to request assistance from military, constabulary, commercial and private vessels. Accuracy: Commercial SATNAV quality	External Nodes <i>Operate PRC</i>	Unit. Navy <i>Process COA</i>
TSN C2 Send/Receive Coordination Constabulary	Course of Action Accuracy: Commercial SATNAV quality and relevant	C2.TSN <i>Direct Response</i>	Unit.Constabulary <i>Process Unit Information</i>
TSN C2 Send/Receive Coordination Military	Course of Action Accuracy: Commercial SATNAV quality and relevant	C2.TSN <i>Direct Response</i>	Unit. Navy <i>Process Unit Information</i>
TSN C2 Send/Receive Intelligence	Intelligence Summary Description: Summary of general intelligence (Law Enforcement and Military sources) in the AOR. Accuracy: Commercial SATNAV quality and Analysis provided and relevant	Intelligence.TSN <i>Post Intelligence Products</i> Intelligence.TSN <i>Download Products</i>	C2.TSN <i>Assess Intentions and Capabilities</i> C2.TSN <i>Process Unit Information</i> C2.TSN <i>Sense Environment</i>
	Request Intelligence Accuracy: Correct Tactical Unit	C2.TSN <i>Optimize Information Act Alternative</i>	Intelligence.TSN <i>Task Data Collection</i>
	Sensed Track Files Accuracy: Commercial SATNAV quality and unambiguous	C2.TSN <i>Provide Unit Sensed Contacts</i>	Intelligence.TSN <i>Process Data</i>
TSN C2 Send/Receive Reachback	Environment Event Accuracy: Commercial SATNAV quality and relevant	C2.TSN <i>Direct Response</i>	External Nodes <i>Operate Environment Monitoring</i>
	Evidence	C2.TSN	External Nodes

Needline	Operational Information Element	Information Source	Information Destination
		<i>Direct Response</i>	<i>Perform Law Enforcement</i>
	Humanitarian Request Accuracy: Commercial SATNAV quality, unambiguous, relevant	External Nodes <i>Operate NGO</i> External Nodes <i>NCO Release</i> <i>Humanitarian Request</i>	C2.TSN <i>Generate COAs</i> C2.TSN <i>Sense Environment</i>
	Law Enforcement Intelligence Description: Law Enforcement Intelligence Operational Information	External Nodes <i>Perform External Activities</i>	C2.TSN <i>Provide TSN</i>
	Logistics Need	C2.TSN <i>Plan Details</i>	External Nodes <i>Determine Desired State</i>
	Objective State Description: International consensus of the desired maritime domain security concerns for an AOR. Accuracy: Released via authority	External Nodes <i>Determine Desired State</i>	C2.TSN <i>Identify Criteria</i>
	Policy and Directives Description: International consensus of the policies and directives for a particular AOR. Accuracy: Released via authority	External Nodes <i>Determine Desired State</i>	C2.TSN <i>Identify Criteria</i>
	Rules of Engagement Description: International consensus of the rules of engagement for a particular AOR. Accuracy: Released via authority	External Nodes <i>Determine Desired State</i>	C2.TSN <i>Identify Criteria</i>
	Situation	C2.TSN <i>Direct Response</i>	External Nodes <i>Determine Desired State</i>
	Status and Update Report Accuracy: Is the report of the intended person or	C2.TSN	C2.TSN

Needline	Operational Information Element	Information Source	Information Destination
	vessel.	<i>Operate Unit</i>	<i>Collect Contact Report</i>
TSN Receive PNT	Position and Timing Description: Satellite navigation signals from one of four global satellite navigation systems. Accuracy: Commercial SATNAV quality	External Nodes <i>Generate Position and Time</i>	External Nodes <i>NGO Receive Position and Timing</i> External Nodes <i>Operate AIS</i> External Nodes <i>Operate Environment Monitoring</i> External Nodes <i>Operate GMDSS</i> External Nodes <i>Operate LRIT</i> External Nodes <i>Operate NCA</i> External Nodes <i>Operate Port</i> External Nodes <i>Operate PRC</i> C2.TSN <i>Process Data</i> C2.TSN <i>Process Unit Information</i> C2.TSN <i>Provide Unit Sensed Contacts</i> C2.TSN <i>Sense Environment</i>

Table 31. DODAF Operational View 3 Information Exchange.

The OV-3 describes which node and operational function interact and with what content.

Operational Information	Description	Attributes	Hierarchical Reference
1 TSN Intelligence Products	Intelligence Product Operational Information		Decomposed By: 1.1 Unit Intelligence Tasking 1.2 Intelligence Summary 1.3 Operational Picture
1.1 Unit Intelligence Tasking	A force unit is tasked to collect intelligence on an object by use of sensors and VBSS techniques.	Priority: high Accuracy: Correct Tactical Unit Timeliness: asynchronous	Decomposes: 1 TSN Intelligence Products
1.2 Intelligence Summary	Summary of general intelligence (Law Enforcement and Military sources) in the AOR.	Priority: medium Accuracy: Commercial SATNAV quality and Analysis provided and relevant Timeliness: periodic	Decomposes: 1 TSN Intelligence Products
1.3 Operational Picture	TSN produced common operational geospatial Awareness from fused sources of information. The information may be provided in different layers where each layer provides different information depending of level of service. Level of service is dependent of role: Authority, Commercial, Private.	Priority: high Accuracy: Commercial SATNAV quality and relevant Timeliness: 30 min	Decomposes: 1 TSN Intelligence Products
2 Intelligence Report and Request	Intelligence Report and Request Operational Information		Decomposed By: 2.1 Intelligence Msg 2.2 Incident Person 2.3 Request Intelligence Summary 2.4 Sensed Track Files 2.5 Request Intelligence 2.6 Incident Vessel
2.1 Intelligence Msg	Intelligence message of HUMNT, SIGINT, ELINT, SNOOPY or other	Priority: high Accuracy: Commercial SATNAV	Decomposes: 2 Intelligence Report and Request

Operational Information	Description	Attributes	Hierarchical Reference
	means. Message may also be a request for information.	quality Timeliness: asynchronous	
2.2 Incident Person	Incident report or contact report of a person of interest. Message may also be a request for information.	Priority: medium Accuracy: Is the report of the intended person. Timeliness: asynchronous	Decomposes: 2 Intelligence Report and Request
2.3 Request Intelligence Summary	A force unit use this information type to request the intelligence summaries.	Priority: medium Accuracy: Commercial SATNAV quality and relevant Timeliness: asynchronous	Decomposes: 2 Intelligence Report and Request
2.4 Sensed Track Files	A force unit provides sensor track files to TSN.	Priority: medium Accuracy: Commercial SATNAV quality and unambiguous Timeliness: asynchronous	Decomposes: 2 Intelligence Report and Request
2.5 Request Intelligence	TSN command and control requests intelligence from TSN intelligence.	Priority: high Accuracy: Correct Tactical Unit Timeliness: asynchronous	Decomposes: 2 Intelligence Report and Request
2.6 Incident Vessel	Incident report or contact report of a vessel of interest. Message may also be a request for information.	Priority: medium Accuracy: Is the report of the intended person. Timeliness: asynchronous	Decomposes: 2 Intelligence Report and Request
3 Unit Reports	Unit Report Operational Information		Decomposes: 3 Unit Reports Decomposed By: 3 Unit Reports 3.1 Sensor Reports 3.2 Environmental Alert TSN Node 3.3 Security Incident

Operational Information	Description	Attributes	Hierarchical Reference
			3.4 Search & Rescue Msg
3.1 Sensor Reports	A force unit provides sensor reports.	Priority: medium Accuracy: Commercial SATNAV quality and relevant Timeliness: periodic	Decomposes: 3 Unit Reports
3.2 Environmental Alert TSN Node	Vessel report of the environmental status, alert or incident.	Priority: medium Accuracy: Correct information Timeliness: asynchronous	Decomposes: 3 Unit Reports
3.3 Security Incident	Security incident from a vessel.	Priority: high Accuracy: Commercial SATNAV quality Timeliness: asynchronous	Decomposes: 3 Unit Reports
3.4 Search & Rescue Msg	Search and rescue message sent from vessel.	Priority: high Accuracy: Commercial SATNAV quality and relevant Timeliness: asynchronous	Decomposes: 3 Unit Reports
4 Tasking	Tasking Operational Information		Decomposed By: 4.1 Course of Action
4.1 Course of Action	The course of action and its tasking is provided to force units.	Priority: high Accuracy: Commercial SATNAV quality and relevant Timeliness: periodic	Decomposes: 4 Tasking
5 TSN and Unit Reachback	Reachback Operational Information		Decomposed By: 5.1 Planned Movement 5.2 Environment Alert Land Node 5.3 Environment Event 5.4 Evidence 5.5 Situation

Operational Information	Description	Attributes	Hierarchical Reference
			5.6 Logistics Need 5.7 Status and Update Report
5.1 Planned Movement	Coordination of a vessel intentions with the PRC.	Priority: medium Accuracy: Correct Tactical Unit Timeliness: asynchronous	Decomposes: 5 TSN and Unit Reachback
5.2 Environment Alert Land Node	Vessel report of the environmental status, alert or incident.	Priority: medium Accuracy: Correct information Timeliness: asynchronous	Decomposes: 5 TSN and Unit Reachback
5.3 Environment Event	Alerts the occurrence of an environmental event.	Priority: high Accuracy: Commercial SATNAV quality and relevant Timeliness: asynchronous	Decomposes: 5 TSN and Unit Reachback
5.4 Evidence	Evidence is provided on vessels and people as the result of an action for use by the prosecutorial elements.	Priority: medium Accuracy: Is the report of the intended object Timeliness: asynchronous	Decomposes: 5 TSN and Unit Reachback
5.5 Situation	TSN provides situation reports and updates to international authorities.	Priority: medium Accuracy: Commercial SATNAV quality and relevant Timeliness: asynchronous	Decomposes: 5 TSN and Unit Reachback
5.6 Logistics Need	TSN logistic needs are provided to international authorities as needed to conduct missions.	Priority: high Accuracy: Quantity and Specification Timeliness: asynchronous	Decomposes: 5 TSN and Unit Reachback
5.7 Status and Update Report	A force unit provides its status with updates to the TSN.	Priority: medium Accuracy: Is the report of the intended person or vessel. Timeliness: asynchronous	Decomposes: 5 TSN and Unit Reachback

Operational Information	Description	Attributes	Hierarchical Reference
6 Navigation Data	Navigation Operational Information		Decomposed By: 6.1 Position and Timing
6.1 Position and Timing	Satellite navigation signals from one of four global satellite navigation systems.	Priority: high Accuracy: Commercial SATNAV quality Timeliness: Commercial SATNAV quality	Decomposes: 6 Navigation Data
7 Land-Centers Information	Land-Centers Operational Information		Decomposed By: 7.1 Center LRIT Summary 7.2 Center AIS Summary 7.3 PRC Summary 7.4 Environment Summary 7.5 Security Alert Summary 7.6 Search & Rescue Summary
7.1 Center LRIT Summary	Composite tracks and LRIT information vessel static voyage and dynamic information.	Priority: medium Accuracy: Commercial SATNAV quality Timeliness: 60 min	Decomposes: 7 Land-Centers Information
7.2 Center AIS Summary	Composite tracks and AIS information with vessel static voyage and dynamic information.	Priority: medium Accuracy: Commercial SATNAV quality and relevant Timeliness: 20 min	Decomposes: 7 Land-Centers Information
7.3 PRC Summary	Composite tracks and PRC information	Priority: medium Accuracy: Commercial SATNAV quality and relevant Timeliness: periodic	Decomposes: 7 Land-Centers Information
7.4 Environment Summary	Summary of the environmental status, alerts and incidents.	Priority: low Accuracy: Commercial SATNAV	Decomposes: 7 Land-Centers Information

Operational Information	Description	Attributes	Hierarchical Reference
		quality and relevant Timeliness: periodic	
7.5 Security Alert Summary	Summary of maritime domain security events with status information.	Priority: medium Accuracy: Commercial SATNAV quality and relevant Timeliness: periodic	Decomposes: 7 Land-Centers Information
7.6 Search & Rescue Summary	Summary of search and rescue events with status information.	Priority: medium Accuracy: Commercial SATNAV quality and relevant Timeliness: periodic	Decomposes: 7 Land-Centers Information
8 International Policy	International Policy Operational Information		
9 Requests	Requests Operational Information		Decomposed By: 9.1 Humanitarian Request
9.1 Humanitarian Request	NGO stakeholders sent requests for Humanitarian assistance to the TSN.	Priority: high Accuracy: Commercial SATNAV quality, unambiguous, relevant Timeliness: asynchronous	Decomposes: 9 Requests
10 Law Enforcement Intelligence	Law Enforcement Intelligence Operational Information	Priority: high Accuracy: Is the report of the intended object Timeliness: asynchronous	
11 Vessel Communications	Means for vessels to coordinate rules of the sea and other matters.	Priority: low Accuracy: Correct Tactical Unit Timeliness: asynchronous	

Table 32. DODAF Operational View 7 Data Model.

The DODAF OV-7 describes operational information data exchange details.

Root	External Node	Intelligence Node	Command and Control Node	Unit Node
	1			1
	2			
	3			
	4			
	5			
	6			
	7			
	8			
	9			
	10			
	11			
	12			
	13			
	14			
	15			
	16			
	17			
	18			
	19			
	20			
	21			
	22			
	23			
	24			
	25			
	26			
	27			
	28			
	29			
	30			
	31			
	32			
	33			
	34			
	35			
	36			
	37			
	38			
	39			
	40			

Figure 58. Design Structured Matrix (Lattix) Complete Analysis Worksheet for Operational Domain.
The DSM analysis matrix maps the nodes and their dependencies as based on operation function clusters.

Task	A	B	C	D	E	F	G	H	I	J	K	L	M	N	O	P	Q	R	S	T	U	V	W	X	Y	Z	AA	AB	AC	AD	AE	AF	AG	AH	AI	AJ	AK	AL	AM	AN						
Perform External Activities 1	1																																													
1.1.1 Identify Gap 2		1																																												
1.1.2 Identify Method 3			1																																											
1.1.3 Plan Gathering 4				1																																										
1.1.4 Release Intelligence Tasking 5					1																																									
1.2.1 Collect Data 6						1																																								
1.2.2 Analyze Data 7							1																																							
1.2.3 Develop Products 8								1																																						
1.3.1 Authenticate Users 9									1																																					
1.3.2 Upload Operational Picture 10										1																																				
1.3.3 Upload Intelligence Products 11											1																																			
1.4.1 Authenticate User Requests 12												1																																		
1.4.2 Download Products 13													1																																	
2.1.5 Receive Humanation Request 14														1																																
2.1.1 Detect Objects and Conditions 15															1																															
2.1.2 Classify Objects and Conditions 16																1																														
2.1.3 Identify Objects and Conditions 17																	1																													
2.1.4 Track Objects and Conditions 18																		1																												
2.1.6 Analyze ISR 19																			1																											
2.2.1 Transform Information 20																				1																										
2.2.2 Evaluate Capabilities 21																					1																									
2.2.3 Evaluate Intentions 22																						1																								
2.2.4 Evaluate Deviation 23																							1																							
2.3.1 Develop Deviation Corrections 24																								1																						
2.3.2 Develop Alternatives 25																									1																					
2.4.1 Identify Criteria 26																										1																				
2.4.2 Evaluate Options 27																											1																			
2.4.3 Optimize Protective Act Alternative 28																												1																		
2.4.4 Optimize Reposition Act Alternative 29																													1																	
2.4.5 Optimize Armed Act Alternative 30																														1																
2.4.6 Optimize VBSS Act Alternative 31																														1																
2.4.7 Optimize Information Act Alternative 32																															1															
2.5.1 Identify Resources 33																															1															
2.5.2 Develop Implementation 34																																1														
2.5.3 Predict Probability of Success 35																																	1													
2.6.1 Generate Commands 36																																		1												
2.6.2 Inform Community 37																																				1										
2.6.3 Issue Commands 38																																														
2.6.4 Prepare Operations 39																																														
4.0 Operate Unit 40																																														

Figure 59. Interpretative Structured Matrix (CADRAT) Complete Analysis for Operational Domain.
The ISM analysis matrix maps the nodes and their dependencies as based on operation function clusters.

IX. APPENDIX OPERATIONAL TEST AND EVALUATION PLAN

A. SECTION 1. INTRODUCTION TO THE STUDY

1. Purpose

Global Maritime Partnership (GMP), an enterprise also referred to as the 1000 Ship Navy (TSN) concept, is composed of maritime nations, the commercial shipping industry and other international partners which have limited knowledge exchange capabilities. The ability to conduct coordinated maritime security and humanitarian assistance operations is hampered when components of the enterprise are not supported by an integrated command and control process. This study seeks to define a systems architecture and information standard for a Command, Control, Communications, Computers and Intelligence (C4I) capability to enable collaboration within the TSN.

2. System Description

The GMP enterprise is reliant on the “cooperation among maritime nations, who share a stake in international commerce, safety, security, and freedom of the seas”. The C2 pattern is employed at the enterprise level, as well as the platform level. To participate in the enterprise the platform must exercise its C2 and contribute towards one or more enterprise C2 activities. The C4I system of systems is composed of the “Watch” chain activities to only include a subset of these activities that occur after an external threat or event. These activities are shared between the military, constabulary, and commercial maritime industrial systems.

B. SECTION 2. MISSION NEED AND OPERATIONAL REQUIREMENT

1. Mission Need

Maritime security is increasingly linked to economic prosperity. It requires a common understanding and combined efforts for action on a global scale. Maritime

security is necessary to ensure freedom of the seas, facilitate freedom of navigation and commerce, advance prosperity and sovereignty, and protect the resources of the oceans. Nations have a common interest in achieving maritime security that underpins economic security; yet terrorism, rogue states, and international criminal activity threaten that security and prosperity. There is a clear imperative for a collaborative international approach to deal with the new global strategic environment. As such, the GMP is consistent with the strategic goals of the Department of State's International Outreach and Coordination Strategy. It solicits international support for maritime security programs and initiatives which are central to an effective global maritime security framework.

2. Operational Requirements

Refer to Chapter IV.

C. SECTION 3. SCOPE OF THE EVALUATION

1. Critical Technical Parameters

Refer to Chapter IV.

2. Critical Operational Issues

- COI 1.: Can the C4I system sense information from multiple sources and generate a relevant common operational picture?
- COI 2.: Can the C4I system maintain data assurance?
- COI 3.: Can the C4I system identify non-military, paramilitary, and non-traditional threat/event?
- COI 4.: Can the C4I system Generate Maritime Tactics for Commander?
- COI 5.: Will the C4I system evaluate options considering complex international relationships?
- COI 6.: Can the C4I system plan and evaluate courses of actions for situation adaptation?
- COI 7.: Can the C4I system allow the user to effectively task the course of action?
- COI 8.: Can the C4I system direct TSN international units to perform course of action?
- COI 9.: Can the C4I system monitor the actions of the units tasked with TSN requirements?
- COI 10.: Can the C4I system survive the operational environment?
- COI 11.: Can the C4I system survive a virtual attack?

COI 12.: Can the C4I system effectively interoperate with international data exchange systems?

3. Measures of Effectiveness/Suitability, Measures of Performance and Data Record

Two distinct MOE and MOP are described shown. In this appendix the operational test and evaluation approach is shown based on the Test and Evaluation course OA 4603. This approach is different from the approach discussed in Chapter IV.

COI 1.: Can the C4I system sense information from multiple sources and generate a relevant common operational?

MOE 1.1.: Percent of accurately receiving data

MOP 1.1.1.: Percent of transmissions received

DR 1.1.1.1.: Total number of packets sent

DR 1.1.1.2.: Total number of data packets lost

MOP 1.1.2.: Accuracy of static ship location

MOP 1.1.3.: Number of nodes the system can accommodate

MOE 1.2.: Percent data fused correctly

MOP 1.2.1.: Timeliness of information

MOP 1.2.2.: Rate at which data fusion identifies and nominates targets

MOE 1.3.: Percent of common operational picture's (COP) generated properly

MOP 1.3.1.: Average time to receive COP after joining network

MOP 1.3.2.: Percent of nodes contributing to the COP

MOP 1.3.3.: Average time to generate COP

COI 2.: Can the C4I system maintain data assurance?

MOE 2.1.: Percent of protected data maintained

MOP 2.1.1.: Percent of protected information correctly segregated from public nodes

DR 2.1.1.1.: Total amount of protected information broadcast to C4I network

DR 2.1.1.2.: Total amount of protected information received by public nodes

MOP 2.1.2.: Average time to validate data from a trusted source and separate protected information from public information

MOP 2.1.3.: Average number of transmission errors

MOE 2.2.: Percent of public data maintained

MOP 2.2.1.: Average number of public nodes sending data to the C4I network per event type

MOP 2.2.2.: Average time to validate public data and relay to security forces

MOP 2.2.3.: Average time to translate foreign data into appropriate common syntax

COI 3.: Can the C4I system identify non-military, paramilitary, and non-traditional threat/event?

MOE 3.1.: Probability that events/threats are statically identified

MOP 3.1.1.: Percentage of non-traditional threats/events correctly identified

DR 3.1.1.1.: Total number of non-traditional threat nodes

- DR 3.1.1.2.: Total number of friendly nodes incorrectly identified as a threat
- MOP 3.1.2.: Average time to identify after detection of suspicious vessel by friendly node
- MOE 3.2.: Probability that security/humanitarian forces are identified properly
 - MOP 3.2.1.: Average time to notify local nodes and security nodes
 - MOP 3.2.2.: Average time for authority nodes to change course to respond to alert
 - MOP 3.2.3.: Percentage of local nodes notified to threat/event
- MOE 3.3.: Probability of events/threats dynamically tracked
 - MOP 3.3.1.: Average number of system tracks
 - MOP 3.3.2.: Mean and variance of data refresh rate
- COI 4.: Can the C4I system generate maritime tactics for commander?
 - MOE 4.1.: Percent of maritime tactical options made available to the commander
 - MOP 4.1.1.: Average number of threats tracked
 - DR 4.1.1.1.: Number of threats that are reported
 - MOP 4.1.2.: Average time threats are identified
 - DR 4.1.2.1.: Time to report a target
 - MOP 4.1.3.: Average number of friendly vessels available to engage
 - DR 4.1.3.1.: Range of friendly resources
 - DR 4.1.3.2.: Status and resources of vessel
 - MOE 4.2.: Probability that a commander can operate within rules of engagement
 - MOP 4.2.1.: Percent of options that meet ROE
 - DR 4.2.1.1.: Number options that meet ROE
 - DR 4.2.1.2.: Number of options that do not meet ROE
 - MOP 4.2.2.: Percent of properly presented ROE's
- COI 5.: Will the C4I system evaluate options considering complex international relationships?
 - MOE 5.1.: Probability that jurisdictional conflicts are identified
 - MOP 5.1.1.: Percent conflicts identified correctly
 - DR 5.1.1.1.: Number conflicts identified
 - DR 5.1.1.2.: Number conflicts not identified or identified in error
 - MOP 5.1.2.: Percent of participants correctly identified as a member of the TSN
 - MOP 5.1.3.: Average time to determine participant's status
 - MOP 5.1.4.: Percent accuracy of participant's roles and responsibilities.
 - MOP 5.1.5.: Percent accuracy of participant's available resources
- COI 6.: Can the C4I system plan and evaluate courses of actions for situation adaptation?
 - MOE 6.1.: Probability that provided COAs are adaptable
 - MOP 6.1.1.: Average number of units that can change from original objective
 - DR 6.1.1.1.: Number of units that can alter objectives
 - DR 6.1.1.2.: Number of units that can not alter objectives
 - MOP 6.1.2.: Average time to reformulate course of actions
- COI 7.: Can the C4I system allow the user to effectively task the course of action?
 - MOE 7.1.: Percentage of the user interface that is flexible
 - MOP 7.1.1.: Percent of user interface that user reconfigures

- DR 7.1.1.1.: Area of user interface that user may modify
- MOP 7.1.2.: User mean time to reconfigure the interface
 - DR 7.1.2.1.: Time the user takes to reconfigure the user interface
- MOE 7.2.: Percentage of the presented data that can be deciphered by the user
 - MOP 7.2.1.: Average time the user needs to read and act on information
 - DR 7.2.1.1.: Time that user reads and takes next action
 - MOP 7.2.2.: Percent of time the user is searching for information
 - DR 7.2.2.1.: Time from initiating a search to finding relevant information that a user needs to perform a task
- COI 8.: Can the C4I system direct TSN international units to perform course of action?
 - MOE 8.1.: Percent of tasking orders translated into internationally recognizable actions
 - MOP 8.1.1.: Percent of common international maritime tactics
 - DR 8.1.1.1.: Number of common international maritime tactics
 - DR 8.1.1.2.: Total number of international maritime tactics
 - MOP 8.1.2.: Average number of task clarification requests
 - DR 8.1.2.1.: Number of task clarification requests
 - MOE 8.2.: Probability of commander tasking TSN units
 - MOP 8.2.1.: Average time to formulate, send and initiate tasking
 - DR 8.2.1.1.: Time to draft the tasking
 - DR 8.2.1.2.: Time to send tasking
 - DR 8.2.1.3.: Time to initiate tasking from receipt of task
 - MOP 8.2.2.: Average distance tasked unit travels from point tasked to destination point
 - DR 8.2.2.1.: Travel distance
- COI 9.: Can the C4I system monitor the actions of the units tasked with TSN requirements?
 - MOE 9.1.: Probability that the commander has supervision of TSN units tasked
 - MOP 9.1.1.: Average time the TSN units are displayed on the situational awareness picture
 - DR 9.1.1.1.: Time a TSN unit symbol is active on the situational awareness picture
 - MOP 9.1.2.: Average radial error of the viewed or reported location of the TSN unit
 - DR 9.1.2.1.: Viewed or reported distance in range, cross range and height relative to truth
 - MOE 9.2.: Probability of predicting vessel courses to appraise likeliness of tactical success
 - MOP 9.2.1.: Rate of planning time forward
 - DR 9.2.1.1.: Projected time from observed location
 - MOP 9.2.2.: Percent of false projections of a unit's track
 - DR 9.2.2.1.: Number of false tracks
- COI 10.: Can the C4I system survive the operational environment?
 - MOE 10.1.: Probability that the system can function in operational environments

- MOP 10.1.1.: Percent availability in operational climate zones
 - DR 10.1.1.1.: Temperature Reading
 - DR 10.1.1.2.: Humidity Reading
 - DR 10.1.1.3.: Sea State
 - DR 10.1.1.4.: Atmospheric pressure
- MOE 10.2.: Percentage of physical security attacks survived
 - MOP 10.2.1.: Number of Minutes prior to Intrusion to Facilities
 - DR 10.2.1.1.: Start Time of Intrusion
 - DR 10.2.1.2.: Stop Time of Intrusion
 - DR 10.2.1.3.: Start Location of Intruding Personnel
 - DR 10.2.1.4.: Start Location of Intrusion Personnel
- COI 11.: Can the C4I system survive a virtual attack?
 - MOE 11.1.: Percentage of thwarted virtual attacks
 - MOP 11.1.1.: Average time of successful virtual attack
 - DR 11.1.1.1.: Time when initiating the virtual attack attempt
 - DR 11.1.1.2.: Time when virtual attacker/hacker has access to information
 - DR 11.1.1.3.: Time when virtual attacker/hacker manipulates information
 - DR 11.1.1.4.: Time when virtual attacker/hacker controls network
 - MOP 11.1.2.: Minimum detection time after virtual attack
 - MOP 11.1.3.: Minimum response time after virtual attack
 - MOE 11.2.: Probability of Denial of Service (DoS)
 - MOP 11.2.1.: Percentage of network bandwidth available prior to DoS
 - MOP 11.2.2.: Percentage of network bandwidth affected by DoS
 - MOE 11.3.: Probability of acceptable recovery after a virtual attack
 - MOP 11.3.1.: Percentage of nodes fully operational
 - MOP 11.3.2.: Percentage of nodes partially operational
- COI 12.: Can the C4I system effectively interoperate with international data exchange systems?
 - MOE 12.1.: Percent of information translated
 - MOP 12.1.1.: Percent successful translation from Stakeholder
 - DR 12.1.1.1.: Data size received
 - DR 12.1.1.2.: Data size translated
 - MOE 12.2.: Percent of information converted to the international data standard
 - MOP 12.2.1.: Percent successful conversion to stakeholder
 - DR 12.2.1.1.: Data size translated
 - DR 12.2.1.2.: Data size converted

COI	Test Objectives and Sub-Objectives	Test
Receiving Capability	To assess the receiving capability of the C4I network: Single node transmit to the network (E-1a) Multiple transmitting nodes (E-1b) Time to relay data from maximum respective ranges of nodes (E-1c) Volume of data passed to the network (E-1d) Common operating picture generation (E-1e)	E-1

COI	Test Objectives and Sub-Objectives	Test
Assurance Capability	To determine data assurance of the C4I network: Convert data into common form (E-2a) Validate data per node type (E-2b) Errors per node type (E-2c)	E-2
Identify Capability	To evaluate the identification capability of the C4I network: Threat classification (E-3a) Natural event classification (E-3b) Notification responding authorities (E-3c)	E-3
Generate Maritime Tactics Capability	To assess generated Maritime Tactics: ROE options (E-4a) Ship details (E-4b) Threat identification alarms (E-4c)	E-4
International Relationship Capability	To evaluate complex International Relationships: Determination of conflicts (E-5a) Identifying participant's status (E-5b)	E-5
Situation Awareness Capability	To plan and evaluate courses of actions for situational awareness: Develop course of action (E-6a) Adapt course of action (E-6b)	E-6
COA Tasking Capability	To assess the utility of the system to help the user to effective task the COA: User screen (S-1a) Comprehension (S-1b)	S-1
International Direction Capability	To assess the capability of the TSN to direct an international unit to perform COA: Interpretation of tasks (E-7a) Timeliness (E-7b)	E-7
Monitoring Capability	To assess the capability to monitor an international TSN unit's actions: Situational awareness (E-8a) Track projection (E-8b)	E-8
Operational Environment Capability	To assess the availability of the system as it operates in its environment: System mean time to failure (S-2a) System mean downtime (S-2b)	S-2
Degraded Operations Capability	To assess the system's vulnerability to cyber attacks: Malicious known and unknown attacks (S-3a) Degraded mode of operation (S-3b)	S-3
Interoperable Capability	To assess the interoperability among the TSN units communication systems: Information exchange (E-9a) Information translation (E-9b)	E-9

Table 33. Test Objective Matrix.

The test objective matrix correlates the COI with test and category.

4. Test Scenarios

- Scenario A. Deliver Humanitarian Aid and Disaster Relief. The TSN evaluates options to provide or support the forceful delivery of humanitarian aid and disaster relief to stricken areas.

- Scenario B. Monitor Environment. The TSN observes and reports acts against the environment and conditions of environmental concern to authorities.
- Scenario C. Prepare Intelligence Information. The TSN collects processes and posts information for users; a user type (warship or constabulary unit) receives information commensurate with the user role.
- Scenario D. Interdict Vessel. The TSN interdicts another vessel in collaboration with other international naval units or constabulary units or both to suppress transnational criminals and smuggling (people, drugs, weapons, and other contraband).
- Scenario E. Perform Planning for AOR. The TSN plans the framework of operations in a particular region based on international objectives, rules and restrictions.
- Scenario F. Generate TSN Operational Picture. The TSN generates a relevant operational picture for a region of interest that is distributed in varying degrees of specificity; a user type receives an operational picture commensurate with the user role.

5. Instrumentation Requirements

1. Scenario A. Deliver Humanitarian Aid and Disaster Relief. The TSN evaluates options to provide or support the forceful delivery of humanitarian aid and disaster relief to stricken areas.
 - a. Data Center
 - b. C2 Center
 - c. Sensor Platforms
 - d. Communications Platforms
 - e. Sea Training Range Areas (Int./Terr.)
 - f. International Ground Training Area
 - g. Port Mooring and instrumentation Area
 - h. Sea platform tracking system
 - i. Information Grid Network Access (terrestrial, BLOS)
 - j. 1 Mock Village post disaster condition
 - k. Simulation of humanitarian aid logistics deliveries
 - l. Simulation of environmental disaster
 - m. logistics and planning team
 - n. center instrumentation team
 - o. platform instrumentation team
 - p. village instrumentation team
 - q. system center operations team
 - r. test squadron team (data/ops center)
 - s. platform skeleton crews
 - t. international authority team

2. Scenario B. Monitor Environment. The TSN observes and reports acts against the environment and conditions of environmental concern to authorities.

- a. Data Center
 - b. C2 Center
 - c. Sensor Platforms
 - d. Communications Platforms
 - e. Sea Training Range Areas (Int./Terr.)
 - f. International Ground Training Area
 - g. Port Mooring and instrumentation Area
 - h. Sea platform tracking system
 - i. Information Grid Network Access (terrestrial, BLOS)
 - j. Simulation of environmental disaster
 - k. logistics and planning team
 - l. center instrumentation team
 - m. platform instrumentation team
 - n. system center operations team
 - o. test squadron team (data/ops center)
 - p. platform skeleton crews
 - q. international authority team
3. Scenario C. Prepare Intelligence Information. The TSN collects processes and posts information for users; a user type (warship or constabulary unit) receives information commensurate with the user role.
- a. Data Center
 - b. C2 Center
 - c. International Ground Training Area
 - d. Information Grid Network Access (terrestrial, BLOS)
 - e. Transnational threat (TNT) <65' vessels
 - f. Simulation of humanitarian aid logistics deliveries
 - g. Simulation of coordinated weapon engagement
 - h. Simulation of environmental disaster
 - i. logistics and planning team
 - j. center instrumentation team
 - k. system center operations team
 - l. test squadron team (data/ops center)
 - m. international authority team
4. Scenario D. Interdict Vessel. The TSN interdicts another vessel in collaboration with other international naval units or constabulary units or both to suppress transnational criminals and smuggling (people, drugs, weapons, and other contraband).
- a. Data Center
 - b. C2 Center
 - c. Sensor Platforms
 - d. Communications Platforms
 - e. Sea Training Range Areas (Int./Terr.)

- f. International Ground Training Area
 - g. Port Mooring and instrumentation Area
 - h. Sea platform tracking system
 - i. Information Grid Network Access (terrestrial, BLOS)
 - j. 3 Transnational threat <65' vessels
 - k. Simulation of coordinated weapon engagement
 - l. logistics and planning team
 - m. center instrumentation team
 - n. platform instrumentation team
 - o. system center operations team
 - p. test squadron team (data/ops center)
 - q. platform skeleton crews
 - r. international authority team
 - s. TNT platform skeleton crews
5. Scenario E. Perform Planning for AOR. The TSN plans the framework of operations in a particular region based on international objectives, rules and restrictions.
- a. Data Center
 - b. C2 Center
 - c. International Ground Training Area
 - d. Information Grid Network Access (terrestrial, BLOS)
 - e. Simulation of humanitarian aid logistics deliveries
 - f. Simulation of coordinated weapon engagement
 - g. Simulation of environmental disaster
 - h. logistics and planning team
 - i. center instrumentation team
 - j. system center operations team
 - k. test squadron team (data/ops center)
 - l. international authority team
6. Scenario F. Generate TSN Operational Picture. The TSN generates a relevant operational picture for a region of interest that is distributed in varying degrees of specificity; a user type receives an operational picture commensurate with the user role.
- a. Data Center
 - b. C2 Center
 - c. Sensor Platforms
 - d. Communications Platforms
 - e. Sea Training Range Areas (Int./Terr.)
 - f. International Ground Training Area
 - g. Port Mooring and instrumentation Area

- h. Sea platform tracking system
- i. Information Grid Network Access (terrestrial, BLOS)
- j. Transnational threat <65' vessels
- k. Mock Village post disaster condition
- l. Simulation of humanitarian aid logistics deliveries
- m. Simulation of coordinated weapon engagement
- n. Simulation of environmental disaster
- o. logistics and planning team
- p. center instrumentation team
- q. platform instrumentation team
- r. village instrumentation team
- s. system center operations team
- t. test squadron team (data/ops center)
- u. platform skeleton crews
- v. international authority team
- w. TNT platform skeleton crews

Test Resources	Limitations to Scope of Test
Sensor Platforms Communications Platforms Sea platform tracking system Information Grid Network Access (terrestrial, BLOS)	The several teams associated with the tests should reflect actual personnel from the international operations community. The TSN vessel platforms may be a combination of test vessels as well as actual volunteers that represent the private community willing to have their vessels outfitted with TSN gear that is packaged for external tie-in.
C2 Center Data Center	In terms of equipment, for the first three scenarios should employ a combination of actual operations hardware and virtual machines and modeling software to simulate the threat environment to test the virtual capabilities of TSN to plan, generate an ops picture, and prepare information.
Simulation of humanitarian aid logistics deliveries Simulation of coordinated weapon engagement Simulation of environmental disaster Transnational threat <65' vessels	In terms of the tests site military ranges both sea based and ground based should be employed to maintain safety and freedom to re-create the environment as much as possible. The TNT threat will have to be simulated by a counter-terrorism team that has studies the enemies' tactics and known technology employed. Actual mitigation by force of the TNT threat will have to employ some type of sea base MILES system. The humanitarian aid threat will have to be simulated as they are referred to as acts of God for a reason. The mitigation transport of material for aid will also have to be simulated. Due to the scope of the type of threats we will have to simulate our COI's for the TNT and Disaster threats will not have as a high a probability of

Test Resources	Limitations to Scope of Test
	confidence as those for the data side only test.

Table 34. Limitation to Scope of Test

The table provides limitations of tests.

D. SECTION 4: OPERATIONAL EFFECTIVENESS

1. Test Scenario Descriptions

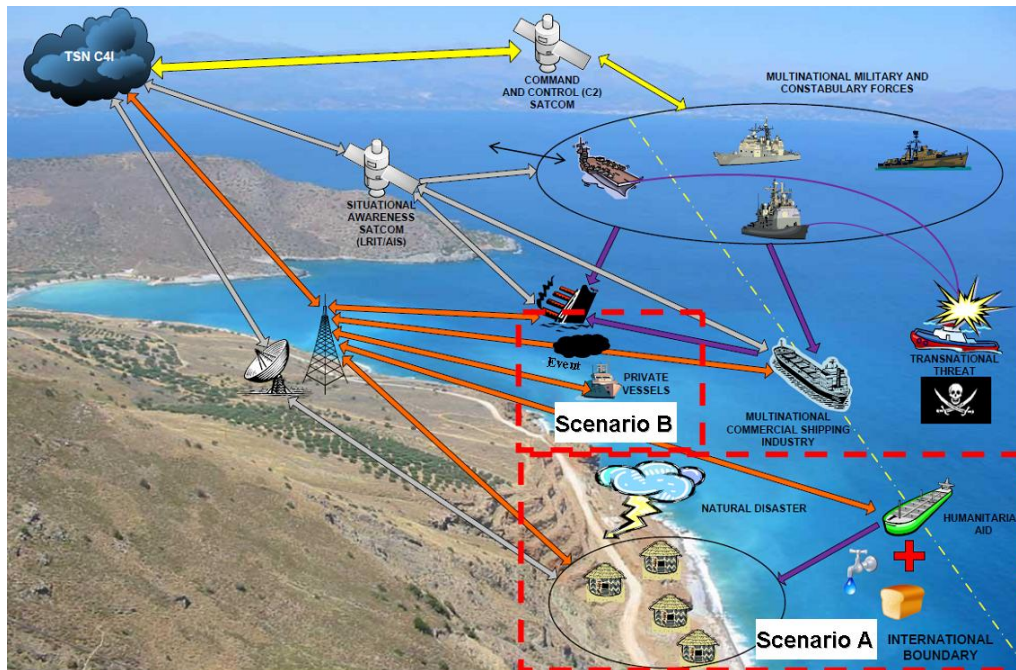

Figure 60 OT&E Plan Scenario Diagram.

Scenario A: Deliver Humanitarian Aid and Disaster Relief. The TSN evaluates options to provide or support the forceful delivery of humanitarian aid and disaster relief to stricken areas.

- Scenario begins with multi-national 1000 Ship Navy (TSN) force positioned in the area of interest performing usual surveillance and assessment operations.
- A Non-Government Organization (NGO), e.g. World Food Program, issues a request to any TSN unit in the vicinity of an area impacted by a natural disaster to provide escort duty for commercial vessel contracted to carry humanitarian aid. [COI: Can the C4I system assess public and protected information in a useful duration?]
- The TSN C4I system recognizes the request and develops a course of action in collaboration with the TSN units in the vicinity. [COI: Can the C4I system allow the user to effectively task the course of action?]

- Each TSN unit confirms assignment to respond to the event. A message is sent to the NGO and commercial vessel describing the specifics of the plan. [COI: Can the C4I system direct TSN international units to perform course of action?]
- One TSN unit departs its patrol area and heads to rendezvous with the commercial vessel. The remaining TSN units adjust position to cover portions of the vacated patrol area. [COI: Can the C4I system direct TSN international units to perform course of action?]
- When in sensor range of the commercial vessel the TSN unit performs a surveillance of the area and establishes a position to follow the commercial vessel. The TSN unit establishes voice communications with the commercial vessel to provide awareness of nearby vessels. [COI: Can the C4I system interoperate with other international units in an effective means?]
- The commercial vessel makes way towards the port with escort.
- The commercial vessel arrives at port.
- TSN unit collaborates with the TSN C4I to determine next task.

Scenario B: Monitor Environment. The TSN observes and reports acts against the environment and conditions of environmental concern to authorities.

- Scenario begins with multi-national 1000 Ship Navy (TSN) force positioned in the area of interest performing usual surveillance and assessment operations.
- A report is received by the TSN C4I from a private vessel of an oil slick in the vicinity of a ship in distress (another scenario). [COI: Can the C4I system identify non-military, paramilitary, and non-traditional threat/event?]
- The TSN C4I system recognizes the report and develops a course of action in collaboration with the TSN units in the vicinity.
- One TSN unit departs its patrol area and heads to the location of the oil slick sighting. The remaining TSN units adjust position to cover portions of the vacated patrol area. [COI: Can the C4I system direct TSN international units to perform course of action?]
- On arrival the TSN unit surveys the oil slick and makes a detailed report of its dimensions and local weather patterns to the TSN C4I. [COI: Can the C4I system monitor the actions of the units tasked with TSN requirements?]
- The TSN C4I updates the situation awareness picture with the information and submits an environmental alert to the nation-states in the region. [COI: Is the C4I system sensing information from multiple sources and generating a relevant common operational picture at a 95 percent confidence?]
- The responding TSN unit remains on station and makes status reports until the arrival of resources for the nation-states to monitor the situation. [COI: Can the C4I system monitor the actions of the units tasked with TSN requirements?]
- On arrival of nation-state resources, the TSN unit collaborates with the TSN C4I to determine next task.

2. E-Tests Descriptions

Test E-1. Receiving capability.

- a. Objective: To assess the receiving capability of the C4I network
- b. Procedure: The C4I network is operated and evaluated in multiple test scenarios to determine the receiving, fusing, and disseminating capability of the C4I system. The system receives multiple static and dynamic ship locations from both LRIT and AIS systems at predetermined ranges. This information is then fused internal to the network and a Common Operating Picture (COP) is promulgated to at least one C2 (protected) node and one local public node.
- c. Data Analysis: COPs are displayed by system instrumentation. Screen captures are recorded and saved to external hard disks. Data fusion error ellipses are recorded by network instrumentation and analyzed against requirements. End-to-end throughput is also analyzed against requirements. The effectiveness is recorded on datasheet E-1 by the system operator and network administrator.

Test E-2. Data assurance capability.

- a. Objective: To evaluate the C4I network's ability to maintain incidence data assurance
- b. Procedure: The C4I network is operated and evaluated in multiple test scenarios to assess the network's ability to maintain and update situational awareness data based on data received from disparate systems. The network timestamps and posts each transmission to the COP with internal instrumentation.
- c. Data Analysis: After initial posting, internal instrumentation measures the duration between each subsequent posting and analyzes it against operational requirements and information assurance decay curves. The effectiveness of the system data assurance is recorded on datasheet E-3 by the system operator.

Test E-3. Identification capability.

- a. Objective: To evaluate the identification capability of the C4I network
- b. Procedure: The C4I network is operated and evaluated in multiple test scenarios to determine the identification capability of the C4I network. The system receives and confirms information from disparate sources. The system then produces and presents multiple identification taxonomy levels on the COP. The system resolves target identification confirmation and uncertainty in reports.
- c. Data Analysis: Identification is resolved by and promulgated across the network. Multiples hostile and friendly contacts are recorded by local

external hard disk with screen captures. Mean and variance of positive identification probability for each test scenario is analyzed against operational requirements. The effectiveness of the system identification is recorded on datasheet E-2 by the system operator.

Test E-4. Generate maritime tactics capability.

- a. Objective: To evaluate the C4I system's ability to generate maritime tactics
- b. Procedure: The C4I system is operated and evaluated in test scenarios to determine its ability to generate maritime tactics for commanders. The system receives information from the network and system instrumentation generates multiple courses of action based on location and type of incident. The system operator records which course of action (COA) is taken, or if an alternative course of action is better.
- c. Data Analysis: The courses of action are recorded by system instrumentation and saved to external hard disks. The system operator records the effectiveness of the suggested courses of action on datasheet E-5.

Test E-5. International Relationship Capability.

- a. Objective: To assess the C4I system's ability to generate COA taking into consideration of multi-national laws and code of conducts
- b. Procedure: The C4I system is operated and evaluated under test scenarios to determine its ability to generate a suitable COA given an incident. The C4I system will produce multiple COAs. The C4I will also produce international and multi-national acceptable rules of engagement and conduct and suggest which COA to take.
- c. Data Analysis: Statistics are generated on number of successfully suggested COAs versus total number of COAs. These results are generated and stored by the instrumented C4I platforms and saved to external hard disk. The effectiveness of the COA suggestion will be recorded by an operator directly under the commanding official who made the decision on data sheet E-5.

Test E-7. Direct International TSN units capability.

- a. Objective: To evaluate the C4I system's ability to relay information to multi-national forces
- b. Procedure: The C4I system is operated and evaluated in test scenarios involving both multi-national security nodes and public nodes. Information is sent from both categories of nodes flagged to one nation,

through the system and relayed to both types of nodes flagged under a different nation. Total number of packets sent versus number received is recorded by system instrumentation and statistics are saved to external hard disks.

- c. Data Analysis: Described above. The system's relay effectiveness is recorded on datasheet E-4 by the system operator.

E. SECTION 5. OPERATIONAL SUITABILITY

1. Test S-2. Surviving the operational environment capability.

- a. Objective: To determine the environmental settings in which the C4I system without interruption to operations.
- b. Procedure: The C4I system will be operated in various temperatures, humidity conditions, sea status, and atmospheric pressures as specified in Scenario A & B that deal with environmental procedures. The system will also have to operate while having a security breaches and the start and stop time of intrusion. The system will also have to locations of intrusions and intruders.
- c. Data Analysis: The time that the C4I system will lose operational capability during the test scenarios will be recorded. Inability to maintain operational status during the different tests can result in a no GO. Confidence levels will be calculated using the t-statistic. The Suitability data will be recorded on Data Sheet S-2.

2. Test S-3. Degraded operations capability.

- a. Objective: To assess the C4I system's ability to survive a virtual attack
- b. Procedure: The C4I system is operated and evaluated under test scenarios to determine its ability to survive a virtual attack. The C4I system is subjected to various unpredictable attacks that target both access to the network and theft of information. The attacks last the duration of the test scenario. If the network is compromised, the time to recover from the attack will be recorded by system instrumentation and the system operator.
- c. Data Analysis: Statistics are generated on number of successful attacks and system recovery time. These results are generated and stored by the attacking platforms and saved to external hard disk. The effectiveness of the system's ability to survive a virtual attack is recorded by the system operator on datasheet S-3.

F. T&E ANNEX A: RESOURCE REQUIREMENTS

Type of Resource	Required
Test Articles	1 Data Center 1 C2 Center 2 Sensor Platforms 2 Communications Platforms
Test Sites	Alpha – Sea Training Range Areas (Int./Terr.) Bravo – International Ground Training Area Charlie – Port Mooring and instrumentation Area
Instrumentation	Sea platform tracking system Information Grid Network Access (terrestrial, BLOS)
Threat Systems and Simulators	3 Transnational threat <65’ vessels 1 Mock Village post disaster condition
Simulations/Models	Simulation of humanitarian aid logistics deliveries Simulation of coordinated weapon engagement Simulation of environmental disaster
Manpower/Personnel Training	1 logistics and planning team 7 weeks 1 center instrumentation team 1 platform instrumentation team 1 village instrumentation team 2 weeks 2 system center operations team 2 test squadron team (data/ops center) 4 platform skeleton crews 2 weeks 1 international authority team 3 TNT platform skeleton crews 3 weeks
Special Requirements	Each platform and threat should be operated from a different nation
T&E Funding	TBD

Table 35. Resource Requirements.

Table list the resources for OT&E.

G.T&E ANNEX B: DATA SHEETS AND QUESTIONNAIRES

Test Problem Report (TPR) Worksheet

Location:

Day:

Time:

Submitted By:

Category (reference deficiency category guide):

Sequence of Events:

Problem Description:

Workaround:

Mission Impact:

Suggested Fix:

Annotate the Deficiency Reports Category (I or II) and the corresponding alpha-numeric priority (1A-5). Submit a Category I Deficiency Report and assign the corresponding priority when a condition:

CAT I	Priority	Impact
	1A	If uncorrected, may cause death, severe injury, or severe occupational illness and no workaround is known; or,
	1B	If uncorrected, may cause major loss or damage to equipment or a system and no workaround is known; or,
	1C	Prevents the accomplishment of an essential capability or critically restricts OSS&E, to include required interaction with other mission critical platforms or systems; and no acceptable workaround is known.
	2A	Adversely affects an essential capability or negatively impacts operational safety, suitability, or effectiveness and no acceptable workarounds are known.
	2B	Adversely affects technical, cost, or schedule risks to the project or to life cycle support of the system, or, results in a production line stoppage and no acceptable workaround is known.

When the condition does not meet the safety or mission impact criteria of a Category I report, submit a Category II Deficiency Report with the corresponding priority (3A-5) when the condition:

CAT II	Priority	Impact
	3A	Adversely affects an essential capability or negatively impacts operational safety, suitability, or effectiveness and adequate performance is achieved through significant compensation or acceptable workaround.
	3B	Adversely affects technical, cost, or schedule risks to the project or to life cycle support of the system, but an acceptable workaround is known.
	4A	Does not affect an essential capability but may result in user/operator inconvenience or annoyance. Adequate performance is achieved through minimal compensation.
	4B	Results in inconvenience or annoyance for development or maintenance personnel, but does not prevent the accomplishment of the task. Adequate performance is achieved through minimal compensation.
	5	Any other effect

NOTES:
 Careful consideration should be given in assigning the category and corresponding priority recommendation to accurately define the deficiencies impact.
 Priority 1A - 1C are considered Emergency Conditions;
 Priority 2A - 3B are considered Urgent Conditions; and
 Priority 4A – 5 are considered Routine Conditions.
 Priority selection, DREAMS field I63, is mandatory for Category I reports and all T&E reports.
 Category I reports shall be coordinated with the appropriate organizational authority prior to submission.
 Originators/Oriinating Points should consider factors such as cost, schedule and performance risks; availability of spares; difficulty of operation or maintenance, repair, or replacement; system redundancy; associated trends; secondary

failures or damages; and environmental impacts among other possible factors.
Workarounds refer to approved / authorized alternate procedures which could include, but are not limited to: manual processes, order of task accomplishment, more restrictive or intensive procedures, and the use of back-up or redundant systems or processes, etc.

Operator Interface Worksheet

Location:

Day:

Time:

Submitted By / MOS:

Previous experience with operations consoles

What is an operations console?

What did you like about the TSN console interface?

What would change in the TSN console interface?

Were the audio loop selection button color, size, and action appropriate for communication control?

What was the easiest action performed through the interface?

What was the most difficult action performed through the interface?

Was the interface display at the appropriate eye level?

Did the PTT interface hand unit or foot pedal respond as expected?

Were all routine functions able to be performed without having to leave the console seat?

Was the audio level for each loop appropriately loud and intelligible?

What should be changed about the TSN interface?

Is there anything else you would like to say?

X. APPENDIX SYSTEM DOMAIN SUPPORTING MATERIAL

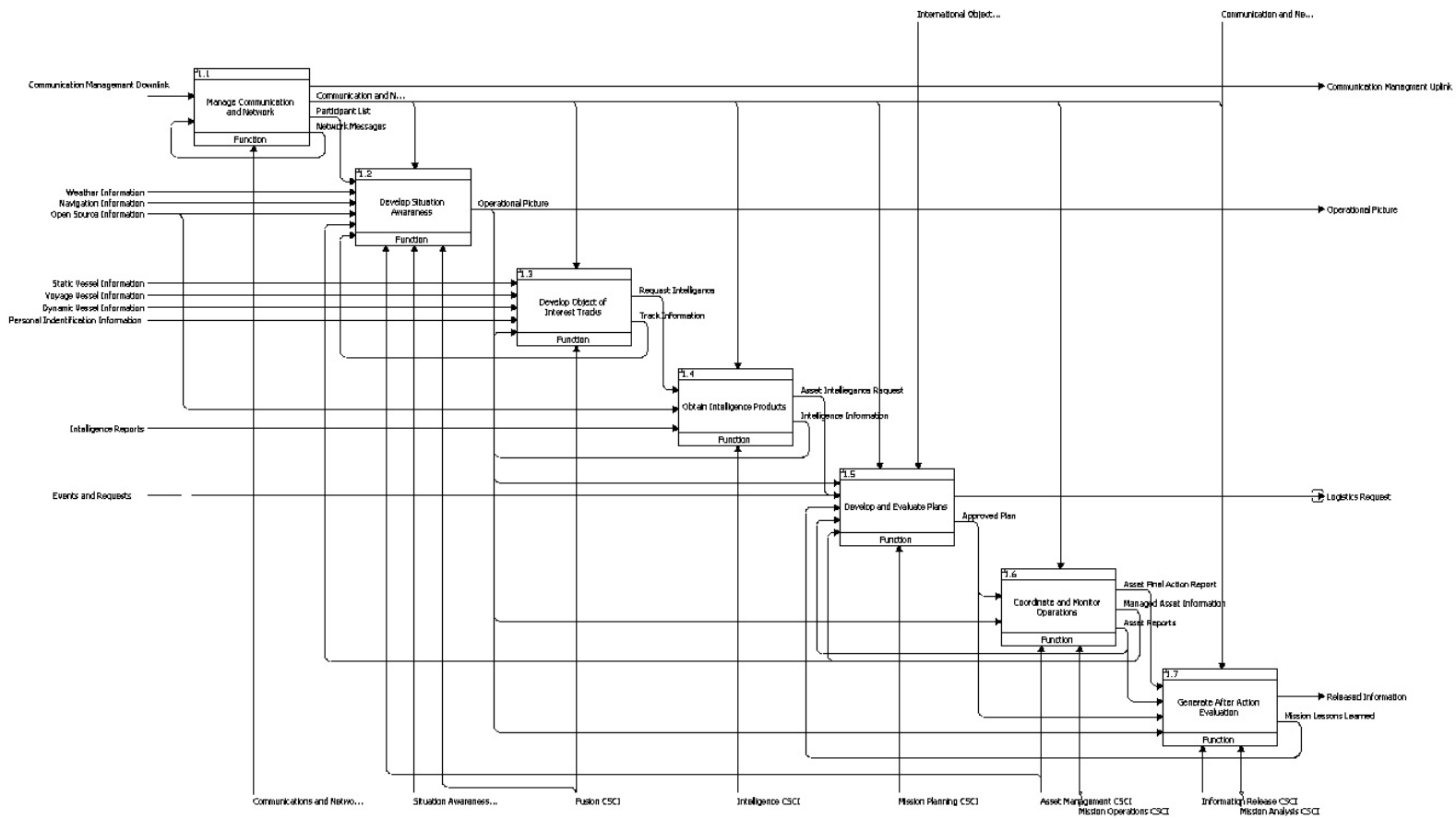

Figure 61. TSN C4I Top Level A-1 IDEF0 Diagram.

Figure shows the system domain top level IDEF0 diagram.

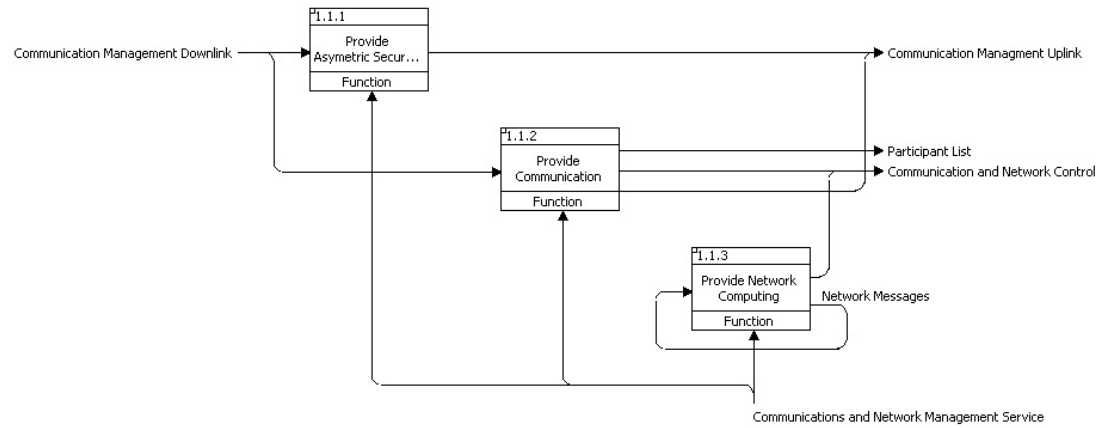

Figure 62. Manage Communication and Network System Function IDEF0 Diagram.

Manage Communication and Networking system function manages external communications, its networks and computing networks

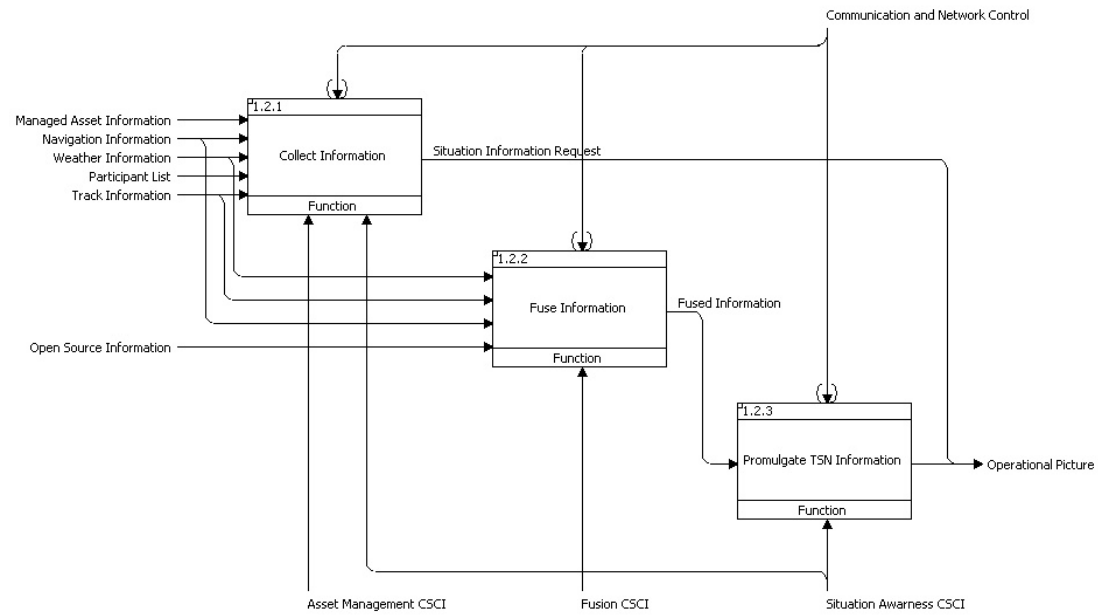

Figure 63. Develop Situation Awareness System Function IDEF0 Diagram.
Situation Awareness system function provides inter-unit information.

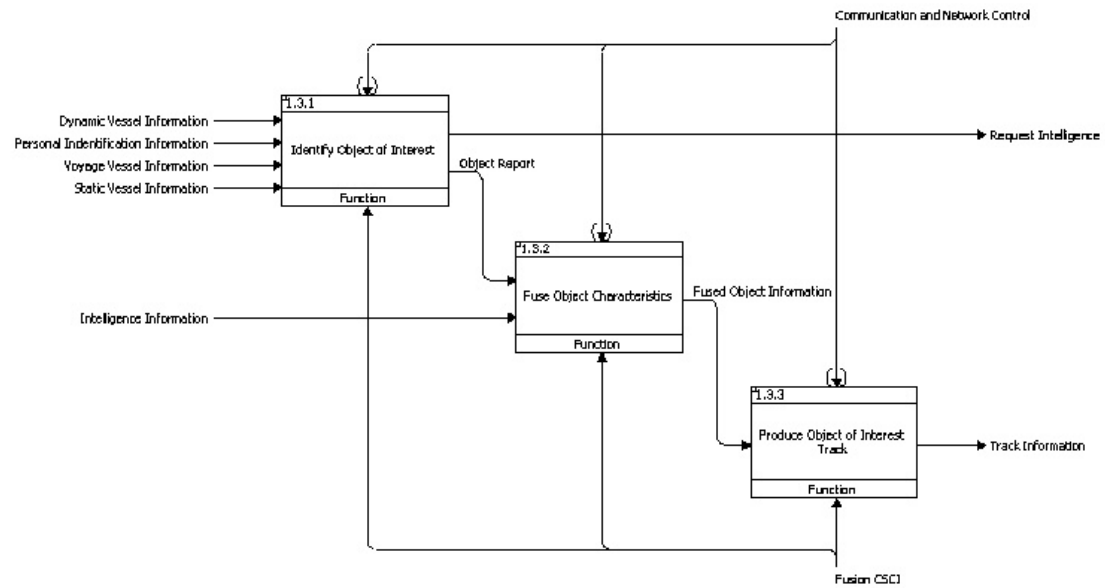

Figure 64. Develop Object of Interest Tracks System Function IDEF0 Diagram.

Develop Object of Interest Tracks system function declares and develops both human and non-human tracks.

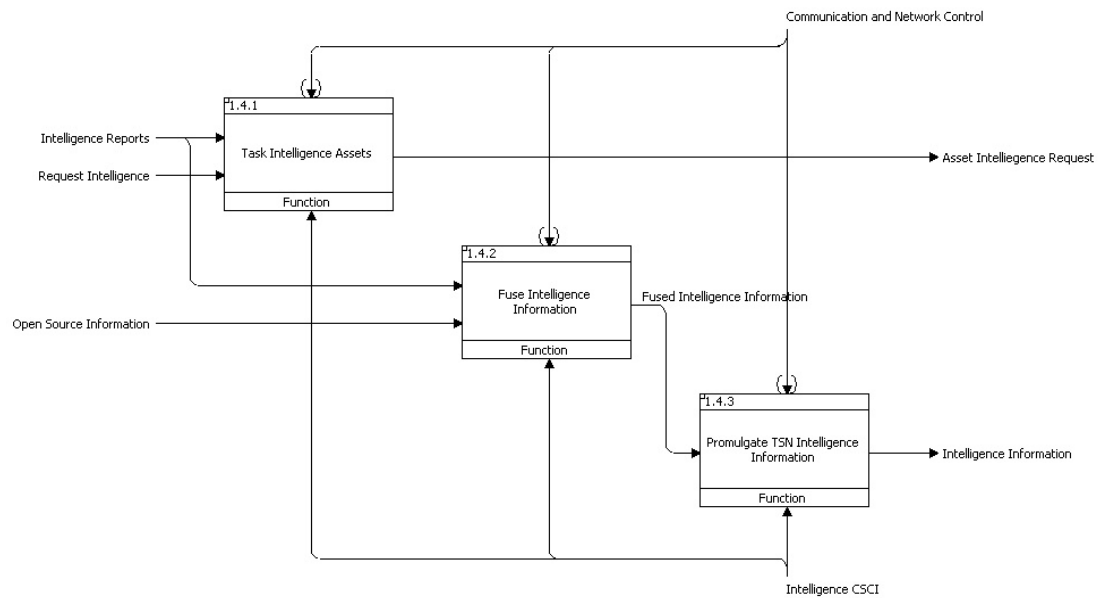

Figure 65. Obtain Intelligence Products System Function IDEF0 Diagram.

Obtain Intelligence Products system function provides intelligence to select TSN units and land based centers.

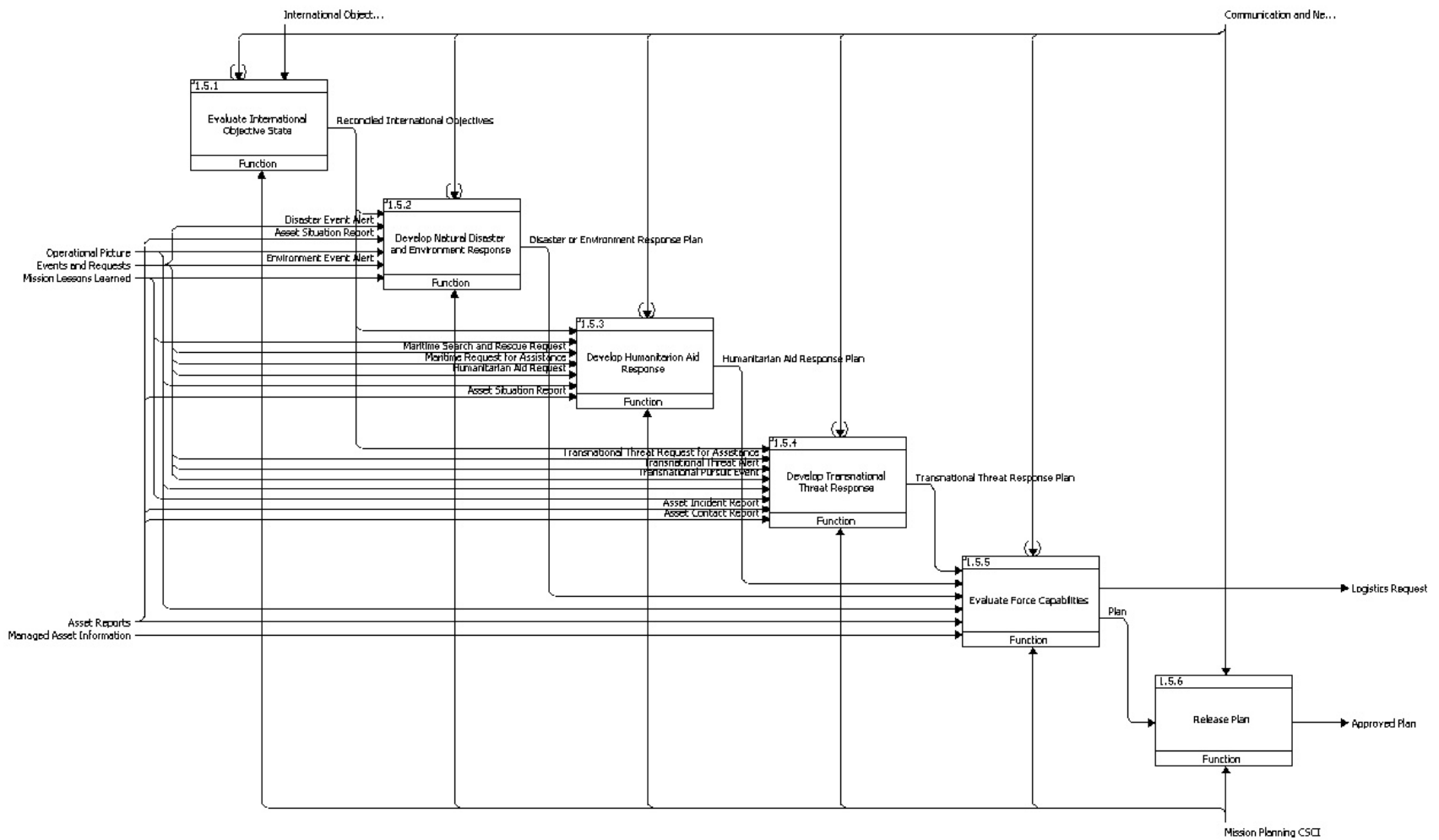

Figure 66. Develop and Evaluate Plans System Function IDEF0 Diagram.
Develop and Evaluate Plans system function provides joint TSN developed plans.

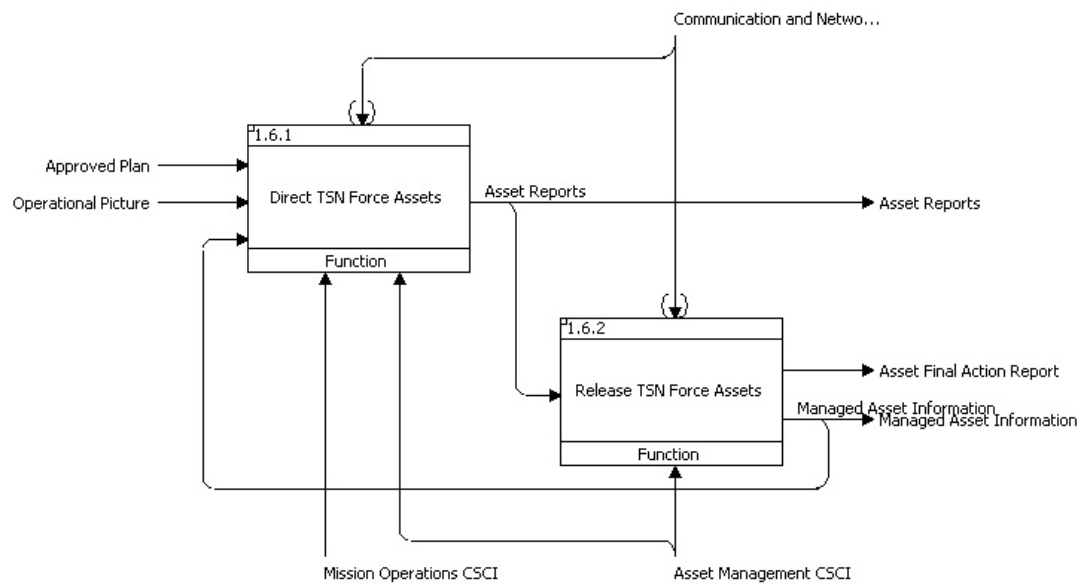

Figure 67. Coordinate and Monitor Operations System Function IDEF0 Diagram.

Coordinate and Monitor Operations system function provides tactical coordination among the TSN force assets

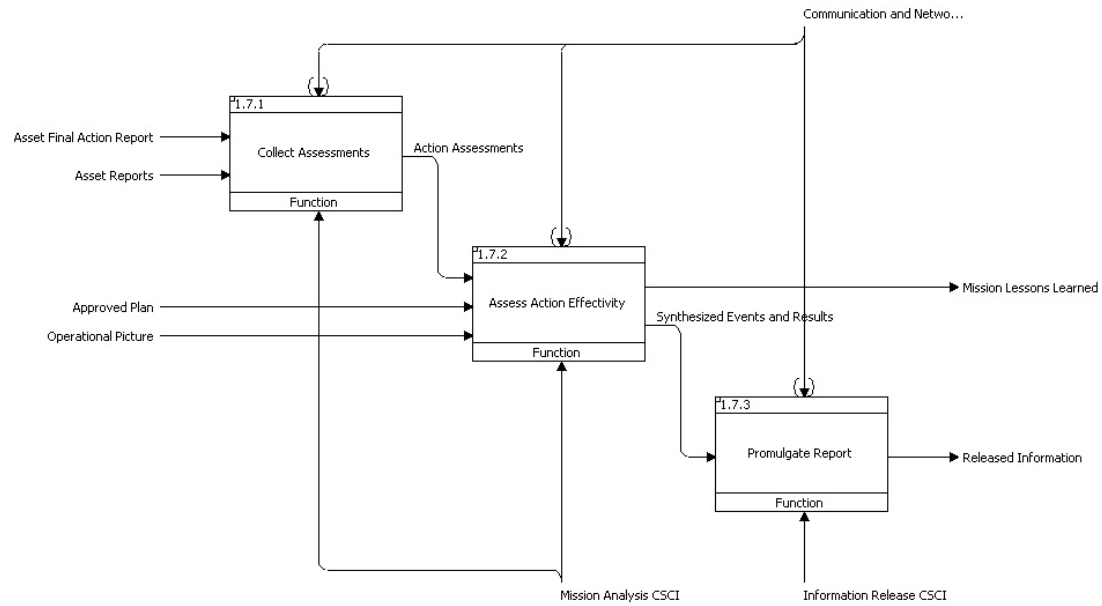

Figure 68. Generate After Action Evaluation System Function IDEF0 Diagram.

Generate After Action Evaluation system function provides generation, review and release of reports to TSN stakeholders.

Information Item	Information Item Payload	Input To Function	Output From Function	Transferred By Software Intf
Static Vessel Information	1.1 Vessel Port Destination 1.2 Vessel Estimated Time of Arrival 1.3 Vessel Estimated Time of Departure 1.4 Vessel Cargo Type 1.5 Vessel Last Visited Ports 1.6 Vessel Crew Data of Birth 1.7 Vessel Crew Name 1.8 Vessel Crew Nationality 1.9 Vessel Crew Passport Number	1.3.1.1 Classify Object	External	TSN.CapInstall.2 Hosted Fusion CSCI
Dynamic Vessel Information	2.1 Vessel Status 2.2 Vessel Alerts	1.3.1.1 Classify Object	External	TSN.CapInstall.2 Hosted Fusion CSCI
Voyage Vessel Information	3.1 Vessel Location 3.2 Vessel Course 3.3 Vessel Rate of Turn 3.4 Vessel Speed	1.3.1.1 Classify Object	External	TSN.CapInstall.2 Hosted Fusion CSCI

Information Item	Information Item Payload	Input To Function	Output From Function	Transferred By Software Intf
Events and Requests	4.1 Humanitarian Aid Request 4.2 Disaster Event Alert 4.3 Environment Event Alert 4.4 Maritime Search and Rescue Request 4.5 Maritime Request for Assistance 4.6 Transnational Threat Alert 4.7 Transnational Enforcement Event 4.8 Transnational Threat Request for Assistance 4.9 Asset Intelligence Request 4.10 Operational Picture Request	1.5 Develop and Evaluate Plans 1.5.2.1 Prepare for Disaster or Environment Response 1.5.3.1 Develop Engineering Assistance and Construction Options 1.5.3.2 Develop Medical and Dental Assistance Options 1.5.3.3 Develop Bulk Aid Protection and Delivery Options 1.5.3.4 Evaluate Use of Force 1.5.4.3 Develop Mitigation Approaches	External 1.4.1.1 Request Intelligence Information	TSN.CapInstall.6 Hosted Mission Planning CSCI TSN.CapInstall.3 Hosted Intelligence CSCI
Approved Plan	5.1 Asset Name 5.2 Asset Sensor Plan 5.3 Asset Movement 5.4 Asset Communication Plan 5.5 Asset Task Objective 5.6 Asset Task Restrictions 5.7 Asset Task Timeline	1.6.1.1 Develop Tasks 1.7.2.2 Compare Events to Plan	1.5.6 Release Plan	TSN.CapInstall.1 Hosted Asset Management CSCI TSN.CapInstall.5 Hosted Mission Operations CSCI TSN.CapInstall.6 Hosted Mission

Information Item	Information Item Payload	Input To Function	Output From Function	Transferred By Software Intf
	and Actions			Planning CSCI
Asset Reports	6.1 Asset Contact Report 6.2 Asset Incident Report 6.3 Asset Situation Report 6.4 Intentions and Movement Report	1.5.2.2 Update Disaster or Environment Plan 1.5.3.4 Evaluate Use of Force 1.5.4.1 Evaluate Criminal Profile 1.5.5.1 Assess Situation 1.6.2.1 Evaluate Asset Action Report 1.7.1.1 Compile Asset Action Reports	1.6.1.3 Status Tasks	TSN.CapInstall.1 Hosted Asset Management CSCI TSN.CapInstall.5 Hosted Mission Operations CSCI TSN.CapInstall.6 Hosted Mission Planning CSCI
Open Source Information	7.1 Weather 7.2 News 7.3 Search	1.2.2.3 Combine Disparate Data Streams 1.2.2.4 Combine Disparate Socio-Political Information 1.2.2.6 Combine Disparate Weather Information 1.4.2.1 Process Open Source Information	External	TSN.CapInstall.3 Hosted Intelligence CSCI TSN.CapInstall.8 Hosted Situation Awareness CSCI

Information Item	Information Item Payload	Input To Function	Output From Function	Transferred By Software Intf
Intelligence Information	8.1 Object Name, Pseudo Name, Alias 8.2 Object Physical Characteristics 8.3 Object Recent History 8.4 Object Contact Sheet 8.5 Object Fingerprints 8.6 Object Image 8.7 Object Audio 8.8 Object Video 8.9 Object Capabilities	1.3.2.1 Combine Image Information 1.3.2.2 Combine Textual Information 1.3.2.3 Combine Video Information 1.3.2.4 Combine Audio Information	1.4.3.2 Approve Intelligence Product for Post	TSN.CapInstall.2 Hosted Fusion CSCI TSN.CapInstall.3 Hosted Intelligence CSCI
Intelligence Reports	9.1 Law Enforcement Blotter 9.2 PRC Information 9.3 AIS Information 9.4 LRIT Information 9.5 Regional Constabulary Information 9.6 Regional Military Information	1.4.1.2 Evaluate Received Intelligence Information 1.4.2.2 Process Asset Provided Information	External	TSN.CapInstall.3 Hosted Intelligence CSCI
International Objectives Control	10.1 International Authority Name 10.2 Statement of Objectives 10.3 Restrictions 10.4 Preferred Methods 10.5 Rules of Engagement	1.5.1.1 Analyze Objectives	External	TSN.CapInstall.6 Hosted Mission Planning CSCI

Information Item	Information Item Payload	Input To Function	Output From Function	Transferred By Software Intf
	10.6 International Authority Role			
Navigation Information	11.1 Navigation Message 11.2 Ephemeris 11.3 Almanac 11.4 Time Reference 11.5 Chart Data 11.6 Map Data 11.7 Navigation Reference Point	1.2.1.5 Evaluate Navigation and Timing 1.2.1.4 Evaluate Persistent Information 1.2.2.5 Combine Disparate Environment Features	External	TSN.CapInstall.8 Hosted Situation Awareness CSCI
Operational Picture	12.1 Weather Overlay 12.2 Chart Overlay 12.3 Topographical Overlay 12.4 Vessel Overlay 12.5 Object of Interest Overlay 12.6 Mission Planning Overlay 12.7 Intelligence Overlay 12.8 Situation Information Request 12.9 Information Need	1.2.1.2 Request Information 1.5.2.2 Update Disaster or Environment Plan 1.5.3.4 Evaluate Use of Force 1.5.4.2 Anticipate Time Critical Issues 1.5.5.1 Assess Situation 1.5.5.3 Evaluate Criminal Capability 1.6.1.2 Coordinate Mission Tasks 1.7.2.2 Compare Events to Plan	1.2.1.2 Request Information 1.2.1.3 Evaluate Time Varying Information 1.2.1.4 Evaluate Persistent Information 1.2.1.5 Evaluate Navigation and Timing 1.2.3.2 Approve Operational Picture Release	TSN.CapInstall.8 Hosted Situation Awareness CSCI

Information Item	Information Item Payload	Input To Function	Output From Function	Transferred By Software Intf
Personal Identification Information	13.1 Name 13.2 Height 13.3 Weight 13.4 Hair Color 13.5 Eye Color 13.6 Ethnicity 13.7 Nationality 13.8 Address 13.9 Passport Number 13.10 National Card Identification Number	1.3.1.1 Classify Object	External	TSN.CapInstall.2 Hosted Fusion CSCI
Released Information	14.1 News Brief 14.2 Situation Report 14.3 Evidence Package	External	1.7.3.1 Prepare News Brief 1.7.3.2 Prepare Situation Report 1.7.3.3 Prepare Evidence Package	TSN.CapInstall.7 Hosted Information Release CSCI
Request Intelligence	15.1 Object of Interest 15.2 Area of Interest 15.3 Type of Information 15.4 Timeframe of Interest 15.5 Needed Date and Time 15.6 Security and Confidentiality Certification	1.4.1.1 Request Intelligence Information	1.3.1.2 Validate Object	TSN.CapInstall.2 Hosted Fusion CSCI TSN.CapInstall.3 Hosted Intelligence CSCI

Information Item	Information Item Payload	Input To Function	Output From Function	Transferred By Software Intf
Track Information	16.1 Track Number 16.2 Track Type 16.3 Track Status 16.4 Track Identification 16.5 Track Location 16.6 Track Trend 16.7 Track Associations	1.2.1.3 Evaluate Time Varying Information 1.2.2.1 Combine Disparate Single Sensor Information 1.2.2.2 Combine Disparate Multi-Sensor Information	1.3.3.2 Release Track Information	TSN.CapInstall.2 Hosted Fusion CSC TSN.CapInstall.8 Hosted Situation Awareness CSCI
Weather Information	17.1 Region 17.2 Wave Height 17.3 Wave Period 17.4 Wave Direction 17.5 Sea State 17.6 Wind Speed Sustained 17.7 Wind Speed Gusts 17.8 Wind Direction 17.9 Visibility 17.10 Cloud Cover 17.11 Precipitation 17.12 Humidity 17.13 Sun Rise and Set 17.14 Moon Rise and Set 17.15 Tidal Conditions 17.16 Effective Period of Forecast 17.17 Barometric Pressure	1.2.1.3 Evaluate Time Varying Information 1.2.2.6 Combine Disparate Weather Information	External	TSN.CapInstall.8 Hosted Situation Awareness CSCI

Information Item	Information Item Payload	Input To Function	Output From Function	Transferred By Software Intf
Communication and Network Control		1.2 Develop Situation Awareness 1.3 Develop Object of Interest Tracks 1.4 Obtain Intelligence Products 1.5 Develop and Evaluate Plans 1.6 Coordinate and Monitor Operations 1.7 Generate After Action Evaluation	1.1.2.1 Provide LOS/BLOS Radio 1.1.2.2 Provide Communication Network Service 1.1.3.1 Provide Network Communication Services 1.1.3.2 Provide Network Infrastructure Service 1.1.3.3 Provide COI Enterprise Service 1.1.3.4 Provide System Management Service	TSN.CapInstall.2 Hosted Fusion CSC TSN.CapInstall.3 Hosted Intelligence CSCI TSN.CapInstall.4 Hosted Mission Analysis CSCI TSN.CapInstall.5 Hosted Mission Operations CSCI TSN.CapInstall.6 Hosted Mission Planning CSCI TSN.CapInstall.7 Hosted Information Release CSCI TSN.CapInstall.8 Hosted Situation Awareness CSCI

Information Item	Information Item Payload	Input To Function	Output From Function	Transferred By Software Intf
Communication Management	19.1 Outages 19.2 Planned Communication Channels 19.3 Participant List 19.4 RF Spectrum Management 19.5 Message Type and Size 19.6 Encryption List 19.7 Communication Management Downlink 19.8 Communication Management Uplink	1.1.1.2 Provide Communications and Transmission Security 1.1.2.1 Provide LOS/BLOS Radio 1.1.2.2 Provide Communication Network Service 1.2.1.1 Manage Asset List	1.1.1.2 Provide Communications and Transmission Security 1.1.2.1 Provide LOS/BLOS Radio 1.1.2.2 Provide Communication Network Service	TSN.CapInstall.1 Hosted Asset Management CSCI TSN.CapInstall.8 Hosted Situation Awareness CSCI
Network Messages	20.1 Packet Loss 20.2 Latency 20.3 Jitter 20.4 Throughput 20.5 Network Routes 20.6 Routing Protocol 20.7 Quality of Service	1.1.3.1 Provide Network Communication Services	1.1.3.1 Provide Network Communication Services	Internal to Communications and Network Management CSCI

Information Item	Information Item Payload	Input To Function	Output From Function	Transferred By Software Intf
Managed Asset Information	21.1 Asset ID 21.2 Asset Sensors 21.3 Asset Weapons 21.4 Asset Status 21.5 Asset Type and Characteristics 21.6 Asset Communications	1.2.1.2 Request Information 1.5.5.2 Evaluate Asset Capability 1.6.1.1 Develop Tasks	1.2.1.1 Manage Asset List 1.6.2.3 Update Asset Status	TSN.CapInstall.1 Hosted Asset Management CSCI TSN.CapInstall.8 Hosted Situation Awareness CSCI
Fused Information		1.2.3.1 Populate Information Overlays	1.2.2.1 Combine Disparate Single Sensor Information 1.2.2.2 Combine Disparate Multi-Sensor Information 1.2.2.3 Combine Disparate Data Streams 1.2.2.4 Combine Disparate Socio-Political Information 1.2.2.5 Combine Disparate Environment Features 1.2.2.6 Combine Disparate Weather Information	TSN.CapInstall.2 Hosted Fusion CSCI TSN.CapInstall.8 Hosted Situation Awareness CSCI

Information Item	Information Item Payload	Input To Function	Output From Function	Transferred By Software Intf
Mission Analysis	23.1 Action Assessments 23.2 Action Issues 23.3 Mission Lessons Learned 23.4 Plan Issues 23.5 Reconstructed Action 23.6 Synthesized Events and Results 23.7 Asset Status Change	1.5.2.1 Prepare for Disaster or Environment Response 1.5.3.1 Develop Engineering Assistance and Construction Options 1.5.3.2 Develop Medical and Dental Assistance Options 1.5.3.3 Develop Bulk Aid Protection and Delivery Options 1.5.4.3 Develop Mitigation Approaches 1.6.2.3 Update Asset Status 1.7.2.1 Reconstruct Action Events and Information 1.7.2.2 Compare Events to Plan 1.7.2.3 Develop Lessons Learned 1.7.3.1 Prepare News Brief 1.7.3.2 Prepare Situation Report 1.7.3.3 Prepare Evidence Package	1.6.2.2 Release Asset 1.7.1.1 Compile Asset Action Reports 1.7.1.2 Gather Affected Area or Object of Interest Status 1.7.2.1 Reconstruct Action Events and Information 1.7.2.2 Compare Events to Plan 1.7.2.3 Develop Lessons Learned	TSN.CapInstall.1 Hosted Asset Management CSCI TSN.CapInstall.4 Hosted Mission Analysis CSCI TSN.CapInstall.6 Hosted Mission Planning CSCI TSN.CapInstall.7 Hosted Information Release CSCI

Information Item	Information Item Payload	Input To Function	Output From Function	Transferred By Software Intf
Mission Planning	24.1 Asset Capability 24.2 Conflicted Objectives 24.3 Criminal Capability 24.4 Disaster or Environment Response Plan 24.4.1 Disaster or Environment Response Update 24.4.2 Disaster or Environment Response Initial Plan 24.5 Humanitarian Aid Response Plan 24.6 Plan 24.7 Reconciled International Objectives 24.8 Request Criminal Response 24.9 Response Timeline 24.10 Transnational Threat Enforcement Approaches 24.11 Transnational Threat Enforcement Plan 24.12 Local Assessment	1.5.2.1 Prepare for Disaster or Environment Response 1.5.3.4 Evaluate Use of Force 1.5.4.3 Develop Mitigation Approaches 1.5.4.4 Rank Mitigation Techniques and Plan 1.5.1.2 Reconcile Objectives 1.5.2.2 Update Disaster or Environment Plan 1.5.5.4 Predict Plan Success 1.5.6 Release Plan	1.5.1.1 Analyze Objectives 1.5.1.2 Reconcile Objectives 1.5.3.1 Develop Engineering Assistance and Construction Options 1.5.3.2 Develop Medical and Dental Assistance Options 1.5.3.3 Develop Bulk Aid Protection and Delivery Options 1.5.3.4 Evaluate Use of Force 1.5.4.1 Evaluate Criminal Profile 1.5.4.2 Anticipate Time Critical Issues 1.5.4.3 Develop Mitigation Approaches 1.5.4.4 Rank Mitigation Techniques and Plan 1.5.5.1 Assess Situation 1.5.5.2 Evaluate Asset Capability 1.5.5.3 Evaluate Criminal Capability 1.5.5.4 Predict Plan Success	TSN.CapInstall.6 Hosted Mission Planning CSCI

Information Item	Information Item Payload	Input To Function	Output From Function	Transferred By Software Intf
			1.5.2.2 Update Disaster or Environment Plan 1.5.2.1 Prepare for Disaster or Environment Response	
Mission Operations	25.1 Asset Final Action Report 25.2 Asset Task Order 25.3 Asset Task Status 25.4 Coordinated Mission Tasks 25.5 Modified Tasks	1.6.1.1 Develop Tasks 1.6.1.2 Coordinate Mission Tasks 1.6.1.3 Status Tasks 1.7.1.2 Gather Affected Area or Object of Interest Status	1.6.1.1 Develop Tasks 1.6.1.2 Coordinate Mission Tasks 1.6.1.3 Status Tasks 1.6.2.1 Evaluate Asset Action Report	TSN.CapInstall.1 Hosted Asset Management CSCI TSN.CapInstall.4 Hosted Mission Analysis CSCI TSN.CapInstall.5 Hosted Mission

Information Item	Information Item Payload	Input To Function	Output From Function	Transferred By Software Intf
				Operations CSCI TSN.CapInstall.7 Hosted Information Release CSCI
Intelligence and Situation Awareness	26.1 Classified Object 26.2 Fused Intelligence Information 26.3 Fused Object Information 26.4 Object Report 26.5 Object Track File 26.6 Validated Object	1.3.1.2 Validate Object 1.3.1.3 Verify Object 1.3.2.1 Combine Image Information 1.3.2.2 Combine Textual Information 1.3.2.3 Combine Video Information 1.3.2.4 Combine Audio Information 1.3.3.2 Release Track Information 1.4.3.1 Prepare Intelligence Product 1.3.3.1 Manage Track File	1.3.1.1 Classify Object 1.3.1.2 Validate Object 1.3.1.3 Verify Object 1.3.2.1 Combine Image Information 1.3.2.2 Combine Textual Information 1.3.2.3 Combine Video Information 1.3.2.4 Combine Audio Information 1.3.3.1 Manage Track File 1.4.2.1 Process Open Source Information 1.4.2.2 Process Asset Provided Information	TSN.CapInstall.3 Hosted Intelligence CSCI TSN.CapInstall.8 Hosted Situation Awareness CSCI

Information Item	Information Item Payload	Input To Function	Output From Function	Transferred By Software Intf
Logistics Request	27.1 Fuel Oil and Lubricants 27.2 Food and Provisions 27.3 Repair Parts 27.4 Medical Supplies 27.5 Port Visit Services 27.6 Personnel (linguists, cultural experts, specialists, etc.) 27.7 Munitions 27.8 Transfer and Ambulatory Service	External	1.5.5.2 Evaluate Asset Capability	TSN.CapInstall.6 Hosted Mission Planning CSCI

Table 36. System Domain Data Item Exchange.

The table summarizes system domain data time exchange between system functions and software interface.

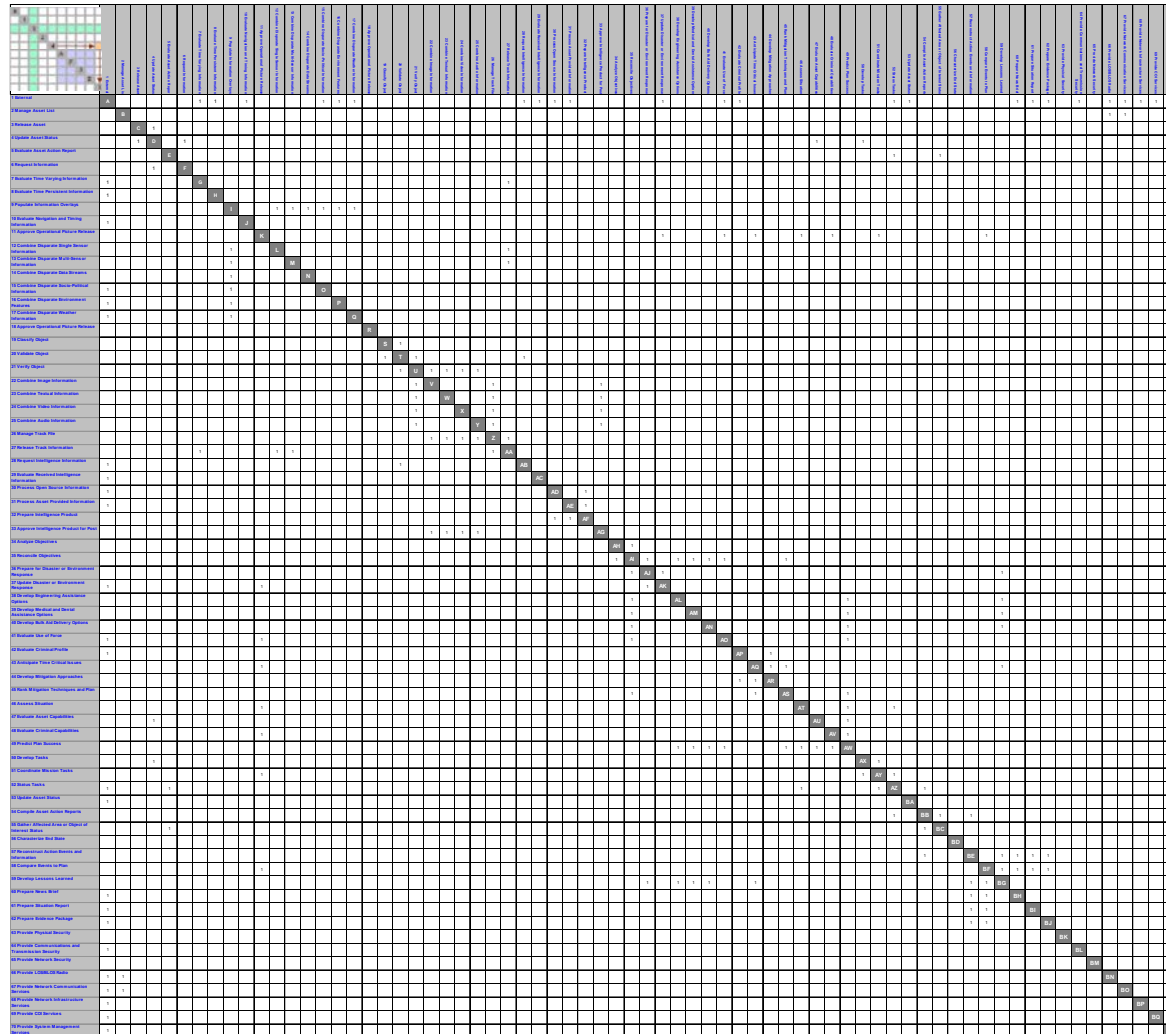

Figure 70. Interpretative Structured Matrix (CADRAT) Complete Analysis Worksheet for System Domain.

The ISM analysis matrix maps the components and their dependencies as based on system function clusters

THIS PAGE INTENTIONALLY LEFT BLANK

XI. APPENDIX INFORMATION EXCHANGE STANDARD

A. SCOPE

1.1 This standard specifies the information requirements for the TSN Command, Control, Communications, Computers and Intelligence (C4I) information network.

1.2 The TSN C4I information network, herein referred to as the TSN network, improves the effectiveness of commercial ship navigational systems such as Automatic Identification Systems (AIS) and Long Range Identification and Tracking (LRIT) by fusing multiple data sources, previously available only at the regional level.

1.3 The TSN network expands the coverage of ship navigational systems by receiving and transmitting situational awareness from private vessels a minimum of 30 ft in length.

1.4 Furthermore, the TSN network does not degrade the performance of the disparate systems providing data to it. It also does not compromise commercial competition or broadcast the location of security forces.

B. VESSEL INFORMATION

The information transmitted by all non-military vessels across the TSN network is divided into four (4) categories and includes:

2.1 Static information:

- Static AIS information defined in MSC.74(69) Annex 3, Section 6
- Static LRIT information defined by the group empowered by MSC.264(84)
- Ship flag

2.2 Dynamic information:

- Required and optional dynamic AIS information defined by MSC.74(69) Annex 3, Section 6
- Dynamic LRIT information defined by the group empowered by MSC.264(84)

- Ship flag
- Time of last transmission to TSN network

2.3 Voyage related information:

- Required and optional voyage related information defined by MSC.74(69) Annex 3, Section 6

2.4 Safety related information:

- Souls on board
- Self defense capabilities (water cannon, warning flares, etc.)
- Type of emergency (natural disaster, piracy, trafficking in humans, etc.)

C. OTHER INFORMATION INPUTS/OUTPUTS

3.1 The TSN network must transmit and receive information from the following sources:

- Local constabulary data sources
- International constabulary data sources
- Sanitized military intelligence data sources
- International air traffic

D. INFORMATION REFRESH RATES

4.1 Information refresh rates for TSN are defined in Table 37.

Data Category:	Threshold	
	Territorial Waters	International Waters
Static	As defined by MSC.74(69)	Every 2 hours and on request
Dynamic	As defined by MSC.74(69)	Every hour and on request
Voyage	As defined by MSC.74(69)	On request
Safety	As defined by MSC.74(69)	As required

Table 37. Data Refresh Rates for the TSN Network

E. INFORMATION ELEMENT

5.1 TSN-001: Static Vessel Element

Static vessel information must maintain tactical relevancy and informational truth of all anchored and non-moving, network-participant vessels within the evolving TSN

mission area for a minimum of 24 hours. This information element, provided by or generated by TSN, contains the vessel's:

- Location segment
- Destination port segment
- Estimated Time of Arrival (ETA) to destination port segment
- Estimated departure time from anchoring segment
- Cargo type segment
- Current voyage port history segment
- Crew information (date of birth, sex, nationality) segment
- Type of emergency segment

5.2 TSN-002: Dynamic Vessel Element

Dynamic vessel information must maintain tactical relevancy and informational truth of all moving network-participant vessels within the evolving TSN mission area for a minimum of 24 hours. This information element, provided by or generated by TSN, contains the static vessel element in addition to the vessel's:

- Course segment
- Rate of turn segment
- Speed segment

5.3 TSN-003: Event and Request Element

Event and request information must be gathered, fused, and promulgated to disparate assets within the evolving TSN mission area in a tactically relevant time for a minimum of 72 hours. This information element, provided by or generated by, TSN contains:

- Humanitarian aid requesting segment
- Disaster alerting segment
- Rescue requesting segment
- Transnational threat alerting segment
- Transnational threat pursuit segment
- Additional asset assistance requesting segment
- Asset external intelligence requesting segment

5.4 TSN-004: Planning Element

Planning information must be evaluated and promulgated to disparate assets within the evolving TSN mission area in a tactically relevant time for a minimum of 3 hours. This information element, provided by or generated by TSN, contains:

- Asset naming segment
- Asset sensor planning segment
- Asset movement segment
- Asset communications and networking planning segment
- Asset objective tasking segment
- Asset restrictions tasking segment
- Timeline and action tasking segment

5.5 TSN-005: Asset Reporting Element

Asset reporting information must maintain tactical relevancy and informational truth of the evolving TSN mission area for a minimum of 30 minutes. This information element, provided by or generated by TSN, contains:

- Asset contact reporting segment
- Asset incident reporting segment
- Asset situation reporting segment
- Asset intentions and movement reporting segment

5.6 TSN-006: Open-Source Element

Open-source information must maintain tactical relevancy and informational truth for a minimum of 7 days. This information element, provided to TSN, contains:

- Weather history and forecast segment
- News segment
- Search for information segment

5.7 TSN-007: Object Information Element

Object information must maintain tactical relevancy and informational truth while being gathered, fused, and promulgated to disparate assets in the evolving TSN mission area for a minimum of 30 minutes. This information element, provided by or generated TSN, contains:

- Object naming and pseudo naming segment
- Object physical characteristic segment
- Object relevant history segment
- Object contact list segment

- Object image segment
- Object audio segment
- Object video segment
- Object capabilities segment

5.8 TSN-008: Intelligence Report Element

Intelligence reporting information must combine disparate, legacy navigation, constabulary, and military reporting systems and maintain both informational truth and tactical relevance in the evolving TSN mission area for a minimum of 3 hours. This information element, provided to TSN, contains:

- Law enforcement blotter segment
- IMB-PRC segment
- AIS information segment
- LRIT information segment
- Navigational segment (ephemeris, navigation messaging)
- Regional constabulary information segment
- Regional military information segment

5.9 TSN-009: International Objectives Element

International objective information must combine and reconcile disparate mission objectives from at least two different national governments, or their agents, within the evolving TSN mission area in a tactically relevant time for a minimum of 30 minutes. This information, provided to TSN, contains:

- International authority name segment
- Objective statement segment
- Objective restriction segment
- Preferred methods segment
- Rules of engagement segment
- International authority role segment

5.10 TSN-010: Common Operating Picture Element

Common Operating Picture information must gather, fuse, filter, and promulgate hierarchically supplied information in a tactically relevant time to disparate assets within the evolving TSN mission area for a minimum of 7 days. This information, provided by or generated by TSN, contains:

- Weather overlay segment

- Chart overlay segment
- Topographical overlay segment
- Vessel overlay segment
- Object of interest overlay segment
- Planning overlay segment
- Intelligence overlay segment

5.11 TSN-011: Communications Link Element

Communications link information must provide hierarchical access and asymmetric security to all information sent to, from, and across the network within the evolving TSN mission area in a tactically relevant time for a minimum of 7 days. This information, provided by or generated by TSN, contains:

- Bit error rate segment
- Power level segment
- Participant segment
- Outages segment
- Communication channels segment
- Message type and size segment
- RF spectrum segment

5.12 TSN-012: Network Management Element

Network management information must provide hierarchical, networked computing to all assets with the evolving TSN mission area in a tactically relevant time for a minimum of 7 days. This information, provided by or generated by TSN, contains:

- Performance segment
 - Packet loss
 - Latency
 - Throughput
 - Quality of service (QOS)
- Topology segment
 - Routing protocol
 - Network routes
- Configuration segment
 - Hardware version
 - Software version

5.13 TSN-013: Tracking Element

Tracking information must declare, identify, and fuse disparate sensor and intelligence information to produce a common object of interest track within the evolving TSN mission area in a tactically relevant time for a minimum of 30 minutes. This information, provided by or generated by TSN contains:

- Track number segment
- Track type segment
- Track status segment
- Track identification segment
- Track location segment
- Track trend segment
- Track association segment

5.14 TSN-014: Personal Identification Element

Personal identification information must be gathered and fused from disparate open source, constabulary, and military systems; then promulgated to assets within the evolving TSN mission area in a tactically relevant time for a minimum of 30 minutes. This information, provided to or generated by TSN, contains:

- Subject name segment
- Physical characteristic segment (Height, weight, hair color, sex, ethnicity)
- Nationality and documentation segment

5.15 TSN-015: Logistics Request Element

Logistics requesting information must gather, fuse, and promulgate requests by assets within the TSN mission area in a tactically relevant time for a minimum of 30 minutes. This information, provided by or generated by TSN, contains:

- Medical segment
- Bulk aid segment (water, grain)
- Petroleum segment
- Repair supplies segment
- Munitions segment
- Personnel segment (cultural specialists, linguists, diplomats)
- Postal service segment
- Transportation/Evacuation services segment
- Port services segment

F. CONFIGURATION ITEMS

6.1 Computer-Software (CSCI):

- SW-001 – Distributed Communications and Networking Management CSCI
- SW-002 – Distributed Situational Awareness Development CSCI
- SW-003 – Information Fusion CSCI
- SW-004 – Distributed Intelligence Product Acquisition CSCI
- SW-005 – Distributed Mission Analysis CSCI
- SW-006 – Distributed Mission Operations CSCI
- SW-007 – Distributed Mission Planning CSCI
- SW-008 – Asset Management CSCI
- SW-009 – Distributed After Action Report Generation CSCI

6.2 Hardware (HWCI)

- HW-001 – External Communications HWCI
 - SATCOM
 - Marine VHF
 - GPS
- HW-002 – Networking HWCI

XII. INITIAL DISTRIBUTION LIST

1. Defense Technical Information Center
Ft. Belvoir, Virginia
2. Dudley Knox Library
Naval Postgraduate School
Monterey, California