

THE WSMR TIMING SYSTEM: APPROACHING THE HORIZON

William A. Gilbert
White Sands Missile Range, New Mexico

Abstract

Over the past couple of years, WSMR has made significant strides in modernizing its Timing System. WSMR has purchased a new Master Timing Generation System (MTGS) to replace a thirty-five year old system. Specifications were written and requirements contracts were developed for Timing distribution equipment which includes Synchronized Time Code Generators (STGs), Versatile Timing Amplifiers (VTAs), and distribution units. This paper will explain why particular designs were chosen, the significance of the MTGS in the WSMR Timing System, and the difficulties associated with implementing a modernization plan.

Introduction

Significant modernization of the WSMR Timing System has not occurred for over twenty-five years. Yes, there have been improvements made, but most of them were from the modification of equipment and small purchases of hardware (mainly for programs with special needs). Over the last three years, however, Timing personnel have worked diligently to find ways to modernize. They developed and adopted a plan that clearly states the goals required for modernization and they established a mechanism to purchase new equipment when funds became available. In 1997, Timing reached one of their stated goals with the purchase and installation of a new Master Timing Generation System (MTGS). This new MTGS replaces a system that's been in service since 1962, which is only a few years older than some of the Synchronized Time Code Generators (STGs) used on the Range. Timing now has fifteen new STGs on hand and will need to purchase and install another three hundred and fifty before fulfilling the current needs.

Another activity that will improve the Timing System's effectiveness and reliability is the consolidation and reduction of Timing facilities. Timing has already started this process by installing the new MTGS at C-Station. C-Station is the current maintenance facility that will eventually house all of the clock, generation, and distribution equipment that resides at Uncle 2 (Present Master Timing Station). This will allow the Timing manager to more efficiently use the available personnel by drawing on the combined resources of both groups from one location. Additionally, Timing has closed several distribution stations and reduced the number of communication circuits required to carry Timing signals. These actions described above are all part of an ongoing process to try and improve the entire Timing System at WSMR. The following paragraphs will discuss in greater detail some of the changes that have occurred in the Timing System at WSMR, and how these changes have improved and provided the foundation for modernizing the Timing System.

Report Documentation Page

*Form Approved
OMB No. 0704-0188*

Public reporting burden for the collection of information is estimated to average 1 hour per response, including the time for reviewing instructions, searching existing data sources, gathering and maintaining the data needed, and completing and reviewing the collection of information. Send comments regarding this burden estimate or any other aspect of this collection of information, including suggestions for reducing this burden, to Washington Headquarters Services, Directorate for Information Operations and Reports, 1215 Jefferson Davis Highway, Suite 1204, Arlington VA 22202-4302. Respondents should be aware that notwithstanding any other provision of law, no person shall be subject to a penalty for failing to comply with a collection of information if it does not display a currently valid OMB control number.

1. REPORT DATE DEC 1997	2. REPORT TYPE	3. DATES COVERED 00-00-1997 to 00-00-1997			
4. TITLE AND SUBTITLE The WSMR Timing System: Approaching the Horizon		5a. CONTRACT NUMBER			
		5b. GRANT NUMBER			
		5c. PROGRAM ELEMENT NUMBER			
6. AUTHOR(S)		5d. PROJECT NUMBER			
		5e. TASK NUMBER			
		5f. WORK UNIT NUMBER			
7. PERFORMING ORGANIZATION NAME(S) AND ADDRESS(ES) White Sands Missile Range, White Sands Missile Range, NM, 87117		8. PERFORMING ORGANIZATION REPORT NUMBER			
9. SPONSORING/MONITORING AGENCY NAME(S) AND ADDRESS(ES)		10. SPONSOR/MONITOR'S ACRONYM(S)			
		11. SPONSOR/MONITOR'S REPORT NUMBER(S)			
12. DISTRIBUTION/AVAILABILITY STATEMENT Approved for public release; distribution unlimited					
13. SUPPLEMENTARY NOTES See also ADA418244. 29th Annual Precise Time and Time Interval (PTTI) Systems and Applications Meeting, Long Beach, CA, 2-4 Dec 1997					
14. ABSTRACT see report					
15. SUBJECT TERMS					
16. SECURITY CLASSIFICATION OF:			17. LIMITATION OF ABSTRACT Same as Report (SAR)	18. NUMBER OF PAGES 7	19a. NAME OF RESPONSIBLE PERSON
a. REPORT unclassified	b. ABSTRACT unclassified	c. THIS PAGE unclassified			

Master Timing Generation System

There are three basic parts that make up the MTGS: a redundant Master Clock, the Time Code Generators (TCGs), and the distribution subsystem (See Figure 1). The Master Clock consists of a Global Positioning System (GPS) receiver and a set of cesium standards. The time code output from the GPS receiver initially synchronizes the TCGs and the frequency output from the selected cesium standard provides the time base. The three TCGs produce IRIG time codes A, B, E, and H in the modulated and DC level formats. These signals go to the Fault Sensing and Switching Unit (FSSU) for analysis, and the FSSU outputs the selected signals for distribution.

The WSMR MTGS produces InterRange Instrumentation Group (IRIG) time code signals. The time represented by these signals is the time of the WSMR Master Clock. To ensure the Master Clock remains within two hundred and fifty nanoseconds of UTC, the Correlator Switching Unit (CSU) constantly monitors and compares the selected standard's output to GPS. If an excessive amount of phase difference develops, the CSU will compare the backup Cesium with GPS and will switch it on line as long as it is within tolerance. By using GPS as a tool for the MTGS, the system has Coordinated Universal Time (UTC) traceability and has the capability to operate independently of the GPS source. This feature is very important since GPS is not always available on the Range.

Other important features of the MTGS are its ability to analyze the Time Code Generators (TCGs) outputs and the ability to switch TCG outputs when the MTGS determines there is a failure. The unit that performs this function is the FSSU. The FSSU uses a majority voting scheme to determine if the selected TCG's output time codes are valid. If the FSSU determines the phase offsets of the on-line TCG's output time codes are excessive when comparing them to the majority, the FSSU places the secondary TCG on line. This minimizes the possibility of time code errors and assures a continuous quality output.

As stated earlier, the new MTGS replaces a 1962 system. It is amazing how the fundamental design of the new MTGS mirrors that of the 1962 system. Yes, the new MTGS uses modern state-of-the-art components, but the fundamental design remains. Just as the fundamental use of the MTGS remains; which is to provide precise time and time interval information to WSMR facilities and to all Range customers. The purchase of the new MTGS assures that this service will continue in the future and provides the foundation upon which to build a modern Timing System.

Synchronized Time Code Generators

Time and time interval information provide a standard reference for all data collection, recording, display, and reduction systems at WSMR. WSMR uses GPS, VHF radio, and communication circuits (voice) to disseminate time signals. Most of the present systems at WSMR use a combination of equipment to obtain time at their sites. For instance, customers using the VHF system use a VHF receiver whose output synchronizes an STG and then its output goes to some other interface to get the time information in the proper format for use. The new STG specified for WSMR incorporates all these features in a single chassis. The new STG has modules available for synchronizing to time information from GPS, VHF, or communication circuits. Additionally, the STG can have more than one synchronizer installed at a time. The STG allows the user to

choose a primary and backup source for synchronization and will automatically switch to the backup synchronizer after the primary synchronizer has failed for a predetermined amount of time. During the period of time between primary failure and secondary switchover, the STG uses the internal oscillator at its last disciplined center frequency as the time base for time accumulation. In areas where a disruption of GPS service may occur, Timing personnel will configure these new STGs with a primary and backup sync source. This ensures quality service will continue under just about any circumstance.

During mission testing at WSMR, the amount of Timing equipment supporting a test can be in the hundreds. Most of the equipment is in the customers' systems, and Timing personnel have to configure it to meet that customer's specific requirements. The new STG will make the job of configuring Timing equipment much easier. The STG has modules that outputs most IRIG serial and parallel time codes, can generate both sinewaves and pulse rates at various frequencies, provides both digital and differential drivers, and has an IEEE interface, to name a few. The new STG has twelve slots to accommodate the different modules required. Essentially, Timing personnel can replace a half of rack of equipment with a single three-and-a-half inch chassis. In these days where space and time are at a premium, this makes a big difference.

Most of WSMR's Timing equipment requires Timing personnel to go out and check it to make sure it is working properly. This increases the amount of personnel and labor hours required to run the Timing system. The new STG will reduce this workload somewhat by having the capability of shipping pertinent information about it to monitor points. Some of the information the new STG can ship remotely includes: the types of modules installed, which slot the module resides in, fault status of each module, menu setup, time information, and oscillator performance. One of the primary goals set forth in the modernization plan by Timing personnel is to find ways to reduce the number of labor hours required to maintain the Timing system. Since there will be three hundred and fifty of these STGs throughout the Range, having a remote capable system sure will help reach that goal. Finally, one other goal that is very important that pertains to the new STG is ensuring its longevity. The STGs that are in use today have been in use for almost thirty years. There is no reason to believe that these new STGs won't have to perform the same feat. For this reason, Timing personnel placed great emphasis on the design and configuration of the new STG. The modular design of the STG, as well as the capability for easily upgrading the software, should aid in accomplishing this goal.

Versatile Timing Amplifiers

At WSMR, fixed (non-tracking) cameras provide a means of measuring the angular direction of an object by recording the object along with external and internal references on photographic film at successive instances in time. These sequences of photographs taken together with Timing data make it mathematically possible to determine a test object's trajectory. The device WSMR currently uses to place Timing on fixed camera film is the Camera Timing Amplifier (CTA). The CTA places precise pulses or Timing pips on film by energizing Light Emitting Diodes (LEDs). To energize these LEDs, the CTA uses each mark cycle of either serial time code format A or B. The code selection is based on the speed of the film and the Timing resolution required. The CTA normally receives its Timing signal via wireline, but the latest version of CTA can use a GPS module to transfer time and generate the required serial time code.

This modern CTA, called the Versatile Timing Amplifier (VTA), has many more uses than the designers envisioned. The VTA has a buffered output of the input signal that can be used to drive other CTAs or other time code equipment (daisy chaining). It's small and compact, weighing less than twelve pounds, and it comes with a battery that can last up to five hours before it requires recharging. This allows Timing personnel to go and set one of these units up in the middle of the desert without any other support and be ready for a test. The VTA also uses a quality oscillator that has a drift rate of less than two microseconds per hour for four hours after GPS has disciplined the oscillator for an hour. Hence, the VTA can exceed most Timing accuracy requirements at WSMR and is versatile enough that Timing personnel can use it most anywhere.

Distribution Units

The primary purpose of the Timing system is to provide time information in formats Range customers can use. This means Timing personnel must interface the Timing outputs from their Timing receivers with whatever equipment the customer has. One important piece of equipment that Timing uses to interface Timing signals with Range equipment is its Distribution Unit (DU). The DUs in use today are a little over twenty years old. They have worked wonderfully, but parts for them are scarce and new requirements exceed their capabilities. Timing has started fixing this problem by replacing them with new modern units. The new DU consists of a base chassis with a plug-in power supply and a variety of plug-in units available for demodulation, amplification, shaping, and distribution of Timing signals. The chassis fit into a standard nineteen-inch equipment rack and will accommodate up to thirteen modules. The two most popular modules scheduled for replacement are the dual-line amplifier and the demodulator amplifier. The dual-line amplifier distributes serial modulated time code formats over a frequency range of 30 hertz to 300 kilohertz (IRIG A,B,D,E,H). The amplifier can drive fifty and six hundred ohm loads with mark-to-space ratio ranging from two to one to six to one. The demodulator amplifier accepts serial modulated time codes as an input and reconstructs the DC level shift version of the time code. Its input to output delay is less than 45 degrees of the carrier frequency and the output is adjustable from 0 to 10 volts. This module typically drives strip chart recorders and FM multiplexing equipment. So far, Timing has twenty DUs and around one hundred and fifty modules, which is far short of what Timing requires to replace these aging units.

Remote Monitor System

Unmanned Timing stations at WSMR use a phase monitor and bit error detection system technique to alert Timing personnel when a discrepancy occurs between two compared signals. This technique compares the phase and time information generated from the sites STGs. Any differences between the time information or an excessive amount of phase will activate an alarm. Timing personnel monitor these alarms at the three customer service centers and take the appropriate corrective actions once an alarm has occurred. The new STGs have an RS-232 output that can provide health, status, and time information. For strategic sites on the Range, Timing personnel now monitor the following:

1. Time information to see if the STG is generating the correct second.

2. The difference between the STG's internal oscillator one Pulse Per Second (1 PPS) and the GPS 1 PPS.
3. The number of satellites the GPS receiver is tracking and the computed location of the receiver STG.

If any of these parameters are out of their normal bounds, immediate action is taken to minimize the effects and harm that it could cause during a test. Additionally, computers at the customer service centers store this information and Timing personnel can review it when required.

Conclusion

Present and proposed missile, satellite, and space research programs require the use of standardized and accurate time formats for the efficient interchange of test data among the various test Ranges, contractors, universities, and Government laboratories. The personnel in the WSMR Timing System are proud of the service they have provided these groups through the years, and want to ensure the service provided in the future is something they can be proud of as well. To ensure that quality service continues in the future or at least to minimize the losses of services that might occur in these times of downsizing, the architects of the Timing modernization program have taken great care in its design. The plan is flexible enough to adapt to changes in technology, funding, and personnel. It provides a means for the Timing System to become modern. All it will take is time, patience, and money as the WSMR Timing System Approaches its New Horizon.

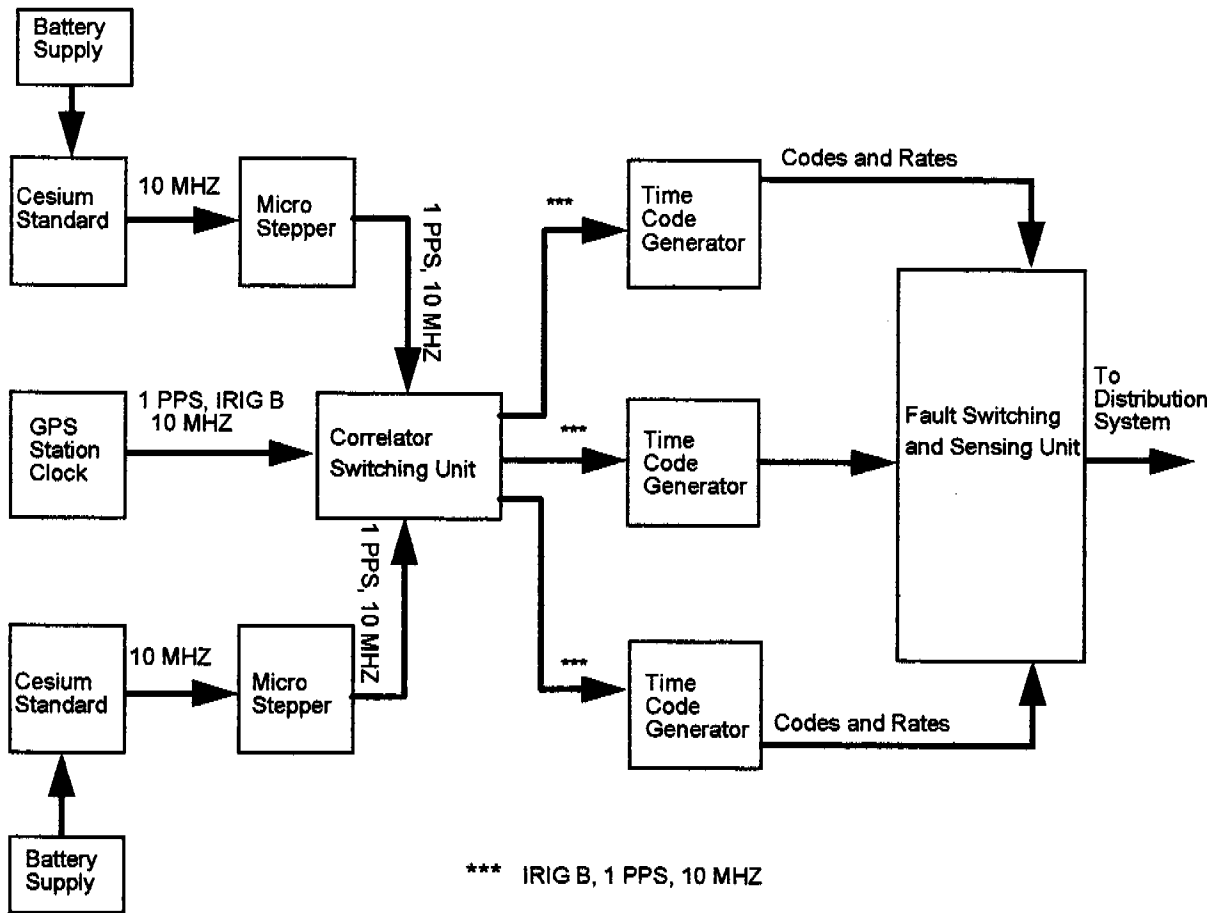

Figure 1 New Master Timing Generation System

Questions and Answers

DON MITCHELL (TRUETIME): What are you going to do with the old timing system?

BILL GILBERT (WSMR): Good question. What we are going to do is first knock down the wall, because when they put the system in, they had to take out a whole wall to get it in. But we are going to put part of it in the museum; and we are probably going to try to see if anybody else would like part of it, because at that time it was state of the art. For those history buffs, it really is "Whoops, oh no," but it is a good piece of equipment. If you have spare parts for it, you probably could fix it and make it work some more. But that is what we are going to do.