

Duke M. Jenkins

Reprinted, without change in pagination, from
PROCEEDINGS OF THE HELMINTHOLOGICAL SOCIETY OF WASHINGTON,
Vol. 15, No. 1, January, 1948.

**A New Nomenclature for the Chaetotaxy of the Mosquito Pupa,
Based on a Comparative Study of the Genera
(Diptera: Culicidae)¹**

KENNETH L. KNIGHT²

Naval Medical Research Institute, Bethesda, Maryland
and

ROY W. CHAMBERLAIN

Department of Parasitology, School of Hygiene and Public Health,
Johns Hopkins University, Baltimore, Maryland

Until rather recently the mosquito pupa has usually been neglected by taxonomic workers. However, as the number of known mosquito species has increased, the necessity for additional species identification characters has caused an increased amount of attention to be directed to the pupal stage, with the result that it has frequently been found to possess good differentiating characters.

Early studies of the mosquito pupa (reviewed by Ingram and Macfie, 1917) disclosed that its rather elaborate chaetotaxy supplied an important source of pupal taxonomic characters. From that time on various systems of nomenclature have been proposed for this chaetotaxy.

A morphological nomenclature, expressive to the greatest extent possible of homologies between species, is, of course, absolutely essential to the taxonomist. To be completely adequate such a nomenclature should also be indicative of homologies from segment to segment within the individual. Such an ideal nomenclature is best obtained by doing a broad preliminary comparative study of representative members of the group being considered. Unfortunately, the nomenclature of mosquito pupal chaetotaxy in common use today did not develop in this manner and, as a result, when previously unstudied genera are met with, the nomenclature is frequently most difficult to apply.

For at least two additional reasons all of the available systems of pupal hair designations are considered by us to be unsatisfactory. First, none of them include all of the known elements of the chaetotaxy; and second, the systems all employ mixed types of name designations (words, numerals, symbols, and letters), a condition which introduces unnecessary difficulties into the mechanical handling of the nomenclature.

The work reported on here was undertaken in an attempt to devise a pupal hair nomenclature based on a comparative study of all the genera of the subfamily Culicinae. All of the pupal hairs and hairless setal rings have been considered, and every effort was taken to make the proposed nomenclature as mechanically simple as possible.

HISTORICAL

Although morphological studies of the mosquito pupal stage were made as early as 1901 by Nuttall and Shipley, no systematic consideration was given to the

¹ This work was supported in part by a grant from the Rockefeller Foundation.

² Lieutenant Commander, U. S. Navy.

Report Documentation Page

Form Approved
OMB No. 0704-0188

Public reporting burden for the collection of information is estimated to average 1 hour per response, including the time for reviewing instructions, searching existing data sources, gathering and maintaining the data needed, and completing and reviewing the collection of information. Send comments regarding this burden estimate or any other aspect of this collection of information, including suggestions for reducing this burden, to Washington Headquarters Services, Directorate for Information Operations and Reports, 1215 Jefferson Davis Highway, Suite 1204, Arlington VA 22202-4302. Respondents should be aware that notwithstanding any other provision of law, no person shall be subject to a penalty for failing to comply with a collection of information if it does not display a currently valid OMB control number.

1. REPORT DATE JAN 1948		2. REPORT TYPE		3. DATES COVERED 00-00-1948 to 00-00-1948	
4. TITLE AND SUBTITLE A New Nomenclature for the Chaetotaxy of the Mosquito Pups, Based on a Comparative Study of the Genera (Diptera: Culicidae)				5a. CONTRACT NUMBER	
				5b. GRANT NUMBER	
				5c. PROGRAM ELEMENT NUMBER	
6. AUTHOR(S)				5d. PROJECT NUMBER	
				5e. TASK NUMBER	
				5f. WORK UNIT NUMBER	
7. PERFORMING ORGANIZATION NAME(S) AND ADDRESS(ES) Naval Medical Research Institute, Bethesda, MD, 20889				8. PERFORMING ORGANIZATION REPORT NUMBER	
9. SPONSORING/MONITORING AGENCY NAME(S) AND ADDRESS(ES)				10. SPONSOR/MONITOR'S ACRONYM(S)	
				11. SPONSOR/MONITOR'S REPORT NUMBER(S)	
12. DISTRIBUTION/AVAILABILITY STATEMENT Approved for public release; distribution unlimited					
13. SUPPLEMENTARY NOTES					
14. ABSTRACT					
15. SUBJECT TERMS					
16. SECURITY CLASSIFICATION OF:			17. LIMITATION OF ABSTRACT	18. NUMBER OF PAGES	19a. NAME OF RESPONSIBLE PERSON
a. REPORT unclassified	b. ABSTRACT unclassified	c. THIS PAGE unclassified			

chaetotaxy until some years later. Macfie (1920) made the first thorough examination of the setae occurring on the pupa, using *Aedes aegypti* (L.) for the study. In his basic and excellent work, he found every seta at present known to occur on that species, overlooking only the dorsal hairless setal ring on abdominal segments III to V. Unfortunately, the nomenclature devised by him used rather lengthy and quite unwieldy word names which have since fallen into disuse. However, some of the capital letters used to label his figures of the abdominal hairs have been carried along and still persist in the nomenclature most commonly used today (the A, B, C hairs for example). In a slightly later paper, Macfie and Ingram (1920) applied the same nomenclature to the pupa of a *Culex* species.

Senevet (1930) developed an extensive modification of Macfie's terminology for use with anopheline pupae. Christophers (1933) slightly modified Senevet's anopheline nomenclature and it is this modification which is in common use for anophelines at the present time.

Crawford (1938) pointed out that Senevet's treatment of the ventral abdominal setae of anophelines is inconsistent with the conditions actually observable, and therefore proposed a new nomenclature for these setae (using word names).

Baisas (1938), using species of *Culex* (*Culex*), *Aedeomyia*, and *Aedes* (*Stegomyia*), attempted to modify the Christophers' nomenclature so that it could be used with both anophelines and culicines.

Edwards (1941) was the first to prepare a really comprehensive series of culicine pupal descriptions. For a nomenclature of the chaetotaxy he accepted that of Baisas (1938), changing only the designation of the large dorsal plumose hair of the first abdominal segment from "dendritic tuft" to "float hair."

MATERIALS AND METHODS

The project reported on here was initiated by obtaining slide-mounted pupal skin specimens of as many of the known mosquito genera and subgenera as possible. Representatives of only two of the 30 recognized mosquito genera were unobtainable: *Heizmannia* Ludlow³ and *Paraëdes* Edwards.⁴ Of the known subgenera, slightly more than one-half were represented in the material examined.

Next, the abdominal segments of at least one species of each of the 28 represented genera were illustrated (the metanotum has been included in these drawings only because it is normally associated with the abdomen in the method of dissection used). In two cases (*Uranotaenia* and *Mansonia*), where significant subgeneric differences were found within a genus, drawings of each of the involved subgenera were prepared. The arrangement of the cephalothoracic hairs was found to be so constant throughout the subfamily that only five illustrations of the cephalothorax (exclusive of the metanotum) were made.

By a combined use of the specimens and drawings a comparative study of the chaetotaxy of the entire subfamily was then made. The purposes of this study were: 1) to determine if each seta of one body segment of the pupa possessed determinable homologues on each of the other segments of the individual, and 2) to determine if each seta of each body segment of the pupa possessed determinable homologues on the equivalent segments in all the other genera of the subfamily. Positive findings for both of these points should then theoretically allow the application of a relatively stable nomenclature to the pupal setae.

³ Mr. P. F. Mattingly has kindly consented to prepare and publish a drawing of the pupal skin of a species of this genus from type material that exists in the British Museum (Natural History). This is to appear in the Proc. Roy. Ent. Soc. London (A) in the near future.

⁴ In the original description of *Paraëdes*, Edwards (1934) states that the early stages are unknown.

The criteria used for the determination of homologies between the elements of the pupal chaetotaxy were: 1) relative position, and 2) degree of development and general appearance. It must necessarily follow of course, that homologies based only on these two points will be subject to error, but until additional or better criteria are discovered these must largely do.

An attempt was made to furnish other criteria by making a rather extensive examination of a number of representative pupae of the subfamily Chaoborinae, which is regarded by some authors to be more primitive in development than the Culicinae, but nothing of help was found. An effort made to locate primitive or generalized setal arrangements by following the phylogenetic generic arrangement proposed by Edwards (1932) was also unsuccessful. Rather, the result of such studies is to show the pupa to be a highly plastic life-cycle stage that is more apt to reflect the environment inherited by it from the larval stage than it does its species phylogeny.

The pupal stage is best studied from the cast skin which is firm enough to mount in balsam and still retain its complete shape. However, for proper study, the skin should be dissected before the cover slip is added. This is perhaps best done by inserting a needle between the junction of the metanotum and the cephalothorax proper and separating these two structures in such a way as to leave the metanotum attached to the abdomen. The remainder of the cephalothorax now opens along the dorsal longitudinal midline and can be easily laid out flat with the outer surface up.

Care must be used in studying pupal chaetotaxy to avoid being confused by anomalous and evanescent structures. Such confusion can usually be guarded against by examining both the right and left sides of a specimen. A noticeable amount of natural variation in the position of hairs also occurs, the extent of which is rather difficult to determine because the abdominal skin seldom lies perfectly flat in the mounting medium.

RESULTS AND DISCUSSION

Since no means of establishing homologies between the cephalothoracic and abdominal hairs were discovered, they are discussed separately.

CEPHALOTHORACIC SETAE. The arrangement of the cephalothoracic setae was found to be remarkably constant throughout the subfamily but the degree and type of development, however was variable.

Although no satisfactory homologies could be established between the cephalothoracic and abdominal setae, it is true that in several genera the appearance and arrangement of the three metanotal setae are such as to suggest a definite relationship between them and hairs 2, 3, and 4 on abdominal segment I. However, nearly as definite a relationship is also apparent in other genera with hairs 7, 8, and 10 of segment I. Since neither relationship could definitely be settled upon, the metanotal setae have been treated along with the other cephalothoracic setae as unrelated to those of the abdomen.

No apparent segmental relationships were found within the cephalothoracic chaetotaxy itself.

As pointed out by Macfie (1920), there are 12 pairs of cephalothoracic setae, one member of each pair being on either side of the midline. These setae occur in 4 natural groups. An examination of pupae nearly ready for adult emergence shows that the three anteroventral setae (the post-ocular setae of Macfie, 1920) are borne on the cephalothoracic sheath over the adult head, that the group of four setae dorsal to the antennal sheath (antero-thoracic setae of Macfie, 1920) and the group of two setae immediately posterior to the trumpet (dorsal and supra-alar setae respectively of Macfie, 1920) are all associated with the meso-

thorax, and that the three metanotal setae (postero-thoracic setae of Macfie, 1920) are over the postnotum.

The setae of the cephalothorax have been designated by us with arabic numerals (1-12), beginning with the most anterior group (the head group) and naming laterally and posteriorly from the dorsal midline in each succeeding group (see Figs. 31-35).

ABDOMINAL SETAE. In general, it was found possible on the basis of similarities in position and development⁵ to establish homologies for the setae of abdominal segments I to VII, both between the hairs of each segment of the individual and between the hairs of equivalent segments of the different genera. However, in structure and in number of setae present, segments VIII to X⁶ are so extensively modified in relation to each other and to the other abdominal segments that no adequate means of determining the homologies of their greatly reduced chaetotaxy were found.

Segment I is also modified in structure and in number of setae present, but no particular difficulty is experienced in determining the relationships of the remaining setae with those of the succeeding segments. Segment II is modified in that it normally possesses a reduced number of ventral setae, but as with I the relationships of the setae present are definitely apparent.

Excluding occasional evanescent hairs and hairless setal rings, the unmodified abdominal segments (III to VII) each possess a maximum of 13 pairs of dorsal, lateral, and ventral hairs, one member of each pair being on either side of the midline. In addition a hairless setal ring is present in most genera on segments III to V. The modified segments range from being hairless to possessing 12 pairs of setae.

To facilitate the task of establishing relationships between the hairs of abdominal segments I to VII, and to make it possible for other workers to trace these derived relationships, an attempt was made to find a key segment from which to proceed in recognizing affinities between the hairs of each segment. An examination of the species used for this study indicated that, of the segments possessing the maximum complement of setae, segment VI seemed to exhibit less variation in hair development and position throughout the subfamily than did any of the others. And indeed, it was found that by beginning with the sixth segment and proceeding in either direction that hair relationships could usually be more readily recognized and justified than by beginning with any of the other segments. Accordingly, this method was the one finally adopted for working out the relationships of the dorsal setae of segments I to VII (the relationships of the true ventral abdominal setae are rather uniformly apparent throughout the subfamily).

By use of the method for determining hair relationships described above, a nomenclature of arabic numerals was then applied. In applying the nomenclature, the dorsal hairless setal ring usually occurring on segments III to V was named 0, and the hairs were numbered 1 through 13, beginning at the dorsal midline and extending laterally and ventrally to the ventral midline. Due to the extensive modification of segments VIII to X, all of the hairs of those segments except 1 and 13 of VIII were arbitrarily assigned numbers. As mentioned previously, the modification of segments I and II is not sufficient to obscure the relationships

⁵ It should be stressed here that determinations of relationships based on the development and appearance of hairs are better done from specimens than from drawings, since the characters are frequently so subtle as to be difficult to illustrate perfectly.

⁶ Following Edwards (1941), the anal flap and the paddles are regarded as representing abdominal segment IX, and the genital pouch as representing segment X.

of the hairs on those segments. It should be borne in mind that no homologies are implied between cephalothoracic and abdominal hairs which bear the same numbers.

For the purposes of discussing the abdominal setae and for clarifying their derived relationships, the modified segments (I, II, VIII, IX, and X) are treated separately from the unmodified segments (III-VII).

Unmodified Segments. On the unmodified segments (III-VII) all of the hairs except 1 and 13 fall into rather well-defined groups, and although almost every variation can and does occur in the development of the various hairs and hair groups, some definitive statements can be made.

Hairs 1 and 13 are on the anterior half of the segments and all the other hairs are in general on the posterior half of the segments.

The dorsal hairless setal ring (designated 0, but not labeled on the plates) of segments III-V is associated either with hair 4, 5, or 6, or with any combination of these. It is entirely missing in the species of *Trichoprosopon* and *Sabethes* studied, and absent from segment III of *Wyeomyia*.

Hair 1 is a remarkably uniform dorsal microseta (in occasional species showing a greater development, however), situated submedially near the anterior margin and well isolated from the other dorsal hairs.

Hairs 2, 3, and 4, which form a rather definite dorsal group in most genera, occupy the most medial position. Hair 2 (the C hair of authors) is usually well developed, and is located on or near the posterior margin of the segment. Excluding hair 1, either 2 or 3 occupies the most median location on the dorsum of each segment; the only consistent exception to this known to us occurs in the genus *Anopheles* where hair 4 on segment VI lies internal to either 2 or 3. In all of the species illustrated here, hair 2 is longer than hair 3 except in *Zeugomyia* and *Eretmapodites*. Another distinct character of hair 2 on the unmodified segments is that it is rather constant in development and position on each segment of an individual (notable exceptions however are *Megarhinus* and *Trichoprosopon*). What is believed to be hair 2 is missing entirely from segments III-VII of *Mansonia* (*Coquillettidia*). The most striking character of hair 3 (hair C' of authors) is that it is usually small, single, and slightly to strongly spinose in character (branched and truly hair-like only in *Bironella*, *Anopheles*, and some *Tripteroides*). In addition, hair 3 is constant in appearance, and very nearly constant in position, on each segment. Hair 4 (hair 4 of authors) is the most difficult of the abdominal hairs to define because of its extremely variable nature, both in development and position. Actually, it is only transiently a group associate with hairs 2 and 3. For example, on segment IV it is associated with the 5-6 group, and frequently also on other segments. In some cases the setal pattern of segment III shows a definite similarity with that of the modified segments I and II, and in these cases, one finds hair 4 retaining the prominent development and the same relative position as on segment II (see *Eretmapodites*). In general, the selection of hair 4 on the unmodified segments is made much easier by first selecting hairs 2, 3, 5, and 6. What is believed to be hair 4 is absent from VII of *Ficalbia* and *Mansonia* (*Mansonioides*).

Hairs 5 (B hair of authors) and 6 (2 hair of authors) form a rather definite group (frequently joined by 4 as pointed out above), which occupies a dorsal postero-sublateral position on the segment, external to the 2, 3, 4 group. Except for variations which may occur on segment III, hair 5 is posterior to 6; and, except on segment VII (and rarely VI) in a number of genera, it is more developed than 6. Frequently, hair 5 on segment III is markedly less developed than on the following three segments. Because of a well-developed 4 hair in many of these cases, there is a natural tendency to call it the 5 hair, but that 5 does not make this decided

jump in position is well evidenced by *Eretmapodites* where both 4 and 5 are easily named by examining the segments on either side. What is believed to be hair 6 is absent from VII of *Mansonia* (*Coquillettidia*).

Hairs 7 (the 1 hair of authors) and 8 (the A hair of authors) form the dorso-lateral hair group and are external to the 5-6 group. Hair 8 is distinct on segments II-VI because of its constant appearance and position. It may range from almost a microspine as in *Culex* to a prominent well-developed spine as in *Anopheles*. Although usually lateral, it may be either dorsal or ventral (on mounted skins at least). The nature of 8 changes markedly on VII where it assumes a similar appearance (usually a multiple plumose hair) to 8 on the modified segment VIII. Hair 7 is internal to 8 and although showing many different forms and degrees of development throughout the subfamily, is quite uniform in position and development on segments II-VI of any individual. As with 8 it usually undergoes a marked change of appearance, and frequently also of position, on VII. In some genera, hair 7 occurs in a ventral position (on mounted skins) on the more posterior segments. Probably what is hair 7 is missing from VII of *Sabethes*.

Hairs 9 and 10 form a ventro-lateral hair group of which hair 9 is the most anterior (except segments III-IV of *Harpagomyia*), and frequently the lesser developed. Hair 9 is distinctly dorsal on the more posterior segments in some genera.

Hairs 11 and 12 form a ventro-sublateral group and lie internal to 9 and 10, and usually also posterior to them. The selection of hair 11 from 12 is not always definitely possible. In general, however, hair 12 is smaller and simpler than 11, and except on segment VI, and frequently VII, is internal to 11. Hair 12 is missing from III-V of *Mansonia* (*Mansonioides*) and is represented by only a hairless setal ring on III-VII of *Mansonia* (*Coquillettidia*).

Hair 13 is similar to hair 1 in being a very uniform microseta. It is situated at the extreme anterior midline of the ventral surface (except in *Trichoprosopon*, where it is associated with the 11-12 group), and is the only pupal seta in which the two members of the pair are intimately associated. In being present or absent, this hair is the most variable of all the abdominal hairs. In the material studied for this project, it was found absent as follows: on segments III-VII in *Sabethes*, *Wyeomyia*, *Phonomyia*, *Harpagomyia*, *Topomyia*, and *Limatus*; on segment III in *Deinocerites*, *Culiseta*, *Zæugnomyia*, *Orthopodomyia*, *Uranotaenia*, and *Eretmapodites*; on segments III-V in *Megarhinus*; and on VI-VII of *Trichoprosopon* and *Opifex*.

The above comments and data on the setae of the unmodified abdominal segments apply, of course, only to the species examined by us. It is extremely doubtful whether in all cases these modifications represent generic or subgeneric characters.

Modified Segments. Segment I, although possessing a remarkably constant pattern throughout the subfamily, is a highly modified segment. This modification is probably due in part to the proximity of the segment to the water surface and also to the cephalothorax. The sternal sclerotization is completely absent, as are also the ventral setae. Hair 1 is also absent. Hair 2 is usually strikingly developed into a large plumose hair (the float hair or dendritic tuft; not illustrated in detail on most of the figures). The postero-lateral two-thirds of this segment is usually membranous with a sclerotized transverse bar (may be mesally discontinuous with the remainder of the sclerotized portion of the segment in some genera) on its surface. Hair 2 arises on the membrane (on the sclerotized portion in *Mansonia*, however) in a notched portion of the sclerotized tergum and near the medial end of the transverse bar. Hairs 3 and 4 are in the anterior submedian position, 3 usually being distinctly smaller than 4. The 5 and 6 hairs form a definite group antero-laterally, 5 usually distinctly larger than 6. In cases where 5 and 6 are

indistinguishable on the criterion of development, it is deemed advisable to treat them together merely as the 5-6 group and not independently. A hair is associated with the 7-8 group on I that is interpreted to be the normally ventral hair 10 of the unmodified segments. This interpretation, although somewhat arbitrary, is based on the usual presence of a similarly appearing hair on segment II which in some species is disassociated from hairs 7 and 8 sufficiently to be in the normal ventral position of hair 10 (*Limatus* for example). Hair 2 is reduced to an ordinary hair in *Mansonia*, *Ficalbia*, and *Opifex*.

Segment II is modified in varying but lesser degrees along the same lines as segment I. This modification probably arises as a result of its position at the water surface in the living pupa along with segment I. For example, hair 2 is frequently distinctly mesad of its usual position and takes on an appearance somewhat similar to hair 2 on segment I (*Deinocerites* for example); and in some anophelines a large posterior membranous area similar to that on I is present. Also, as previously pointed out, the hair arrangement of segment II is obviously similar to that on I. Hair 10 is the only ventral hair consistently present on segment II, and it is as often dorsal as ventral. Hairs 9, 11, and 12 may be entirely absent (as in *Bironella*), or present in any combination of one or more (for example, all present in *Limatus*). Hair 13 was found on this segment only in *Tripteroides*.

Segment VIII, although variously modified in shape, has a markedly constant pattern of 4 setae. Hair 1 is always present, although sometimes more posteriorly than is normal on the unmodified segments. Hair 13, which was found in all genera except *Megarhinus*, is nearly always more laterally placed than on the preceding segments. Although the homology of the hair on the postero-lateral angle of the segment is usually clear from a comparison with segment VII, enough exceptions were found (see *Ficalbia* and *Uranotaenia*) to make it necessary to name it arbitrarily (hair 8). In the same manner and because of this strong similarity between the postero-lateral hairs of VII and VIII, hair 8 has sometimes been selected on VII by appearance, without regard to position. It seems quite likely that in some genera, the postero-lateral hair of VIII is actually hair 7, but to attempt to delineate these cases would mean having some situations in which no decision could be made at all; consequently, it was felt that an arbitrary decision was the best course. The slighter hair located mesad of 8 and overhanging the base of the paddle was also arbitrarily named (hair 5), since it too may resemble various hairs on segment VII in the different genera.

Segment IX. Medially produced from the posterior margin of segment VIII is a dorsal flap which is designated as the anal flap. This and the paddles (following Edwards, 1941) are regarded as the remnants of segment IX. In a number of the genera a small lateral hair is present on the anal flap and it has been arbitrarily designated as hair 1 by us. The paddle hair has arbitrarily been named hair 8 (absent in *Megarhinus*, all of the sabethines, *Mansonia*, and *Ficalbia*). In the anophelines, a ventral accessory paddle hair is present and in *Uranotaenia* (*Pseudoficalbia*) and *Culex* a medial terminal accessory paddle hair occurs. In both positions, this accessory hair has arbitrarily been designated as hair 7.

Segment X. The genital sac is regarded as part of segment X. In *Megarhinus*, it bears a prominent branched hair which has arbitrarily been designated as hair 8 (genital hair).

SUMMARY

A comparative study of the chaetotaxy of the mosquito pupa was made by examining and illustrating the pupa of at least one species each of 28 of the 30 known mosquito genera.

No means of establishing homologies between the cephalothoracic and ab-

dominal hairs were discovered. The 12 pairs of cephalothoracic setae were designated with arabic numerals (1-12), beginning with the most anterior group and naming laterally and posteriorly the hairs in each succeeding group.

In general, it was found possible on the basis of similarities in position and development to establish homologies for the setae of abdominal segments I to VII, both between the hairs of each segment of the individual and also between the hairs of equivalent segments of the different genera studied. However, segments VIII to X were found to be so extensively modified that no means of determining the homologies of their setae with those of the other abdominal segments were discovered.

In establishing the relationships between the hairs of segments I to VII, it was found that by proceeding in either direction from VI hair relationships could usually be more readily recognized and justified than by beginning with any other segment.

By the use of this method for determining hair relationships, a nomenclature of arabic numerals (0-13) was applied to the setae and hairless setal rings of segments I to VII, beginning at the dorsal midline and extending laterally and ventrally to the ventral midline. The hairs of segments VIII to X were arbitrarily named with arabic numerals.

ACKNOWLEDGMENTS

Of the pupal collection assembled for this investigation, 15 of the species were from the collection made in the Pacific in 1945 under the auspices of U. S. Naval Medical Research Unit 2 by L. E. Rozeboom, K. L. Knight, and J. L. Laffoon. These specimens are all to be deposited in the U. S. National Museum. The remainder of the material was made available to us through the generosity of Alan Stone, U. S. National Museum; P. F. Mattingly, British Museum (Natural History); H. R. Roberts, Academy of Natural Sciences of Philadelphia; L. J. Dumbleton, Dept. Scientific and Industrial Research, Wellington, New Zealand; H. R. Dodge, U. S. Public Health Service; and L. E. Rozeboom, Johns Hopkins University. To these people we wish to express our sincerest appreciation.

LITERATURE CITED

- BAISAS, F. E. 1938. Notes on Philippine mosquitoes, VII. Monthly Bull. Philippine Hlth. Serv. 18: 175-232.
- CHRISTOPHERS, S. R. 1933. The Fauna of British India. Diptera. 4. 371 pp. Taylor and Francis, London.
- CRAWFORD, R. 1938. Some anopheline pupae of Malaya with a note on pupal structure. 110 pp. Gov. Straits Settlements and Malaria Advisory Board, Federated Malay States, Singapore.
- EDWARDS, F. W. 1932. Genera Insectorum. Family Culicidae. Fasc. 194. 285 pp. P. Wytzman, Brussels.
- . 1934. Appendix. In: Barraud, P. J. The Fauna of British India. Diptera. 5: 427-453. Taylor and Francis, London.
- . 1941. Mosquitoes of the Ethiopian Region. 3. 499 pp. British Museum (Natural History), London.
- INGRAM, A., and MACFIE, J. W. S. 1917. Notes on some distinctive points in the pupae of West African mosquitoes. Bull. Ent. Res. 8: 73-91.
- LANE, J., and CERQUEIRA, N. L. 1942. Os sabetíneos da America (Diptera, Culicidae). Arquivos de Zoologia do Estado de São Paulo 3: 473-849.
- MACFIE, J. W. S. 1920. The chaetotaxy of the pupa of *Stegomyia fasciata*. Bull. Ent. Res. 10: 161-169.
- , and INGRAM, A. 1920. The early stages of West African mosquitoes, V. *Culex decens* Theo. and *Culex invidiosus* Theo. Bull. Ent. Res. 11: 105-112.
- NUTTALL, G. H. F., and SHIPLEY, A. E. 1901. Studies in relation to malaria. II. The structure and biology of *Anopheles maculipennis*. III. The pupa. Jour. Hyg. 1: 269-275.

SENEVET, G. 1930. Contribution a l'étude des nymphes de Culicides. 1st Memoire. Arch. Inst. Pasteur Algérie 8: 297-382.

EXPLANATION OF FIGURES

The cephalothoracic drawings are of skins opened along the dorsal midline with the outer surface up. The ventral midline is median in the complete drawing and at the right in the incomplete figures. All of the metanotal and abdominal drawings show the ventral surface on the left and the dorsal surface on the right. In each case the first segment shown is the metanotum.

The systematic arrangement used in the following pages is, except for the treatment of the sabethines, according to Edwards (1932). Following Lane and Cerqueira (1942) the sabethines have been raised to tribal rank and certain generic changes adopted.

Unless otherwise stated, the specimens used for the drawings are all deposited in the U. S. National Museum, Washington, D. C.

Metanotal and Abdominal Figures.

Anophelini

- Figure 1. *Chagasia bathanus* (Dyar). Panama.
 " 2. *Bironella (Brugella) hollandi* Taylor. Poha River, Guadalcanal Island, Solomons (L. E. Rozeboom). Ex stream margin.
 " 3. *Anopheles (Myzomyia) farauti* Laveran. Hollandia, Dutch New Guinea (H. Hoogstraal).

Megarhinini

- " 4. *Megarhinus amboinensis* (Doleschall). Group *Toxorhynchites*. Lake Sentani, Hollandia, Dutch New Guinea (K. L. Knight). Ex coconut shell.

Sabethini

- " 5. *Trichoprosopon (Trichoprosopon) compressum* Lutz. Rio de Janeiro, Brazil (L. Whitman).
 " 6. *Tripteroidea (Mimeteomyia) caledonica* (Edwards). Espiritu Santo Island, New Hebrides (J. L. Laffoon). Ex tree hole.
 " 7. *Sabethes (Sabethinus) aurescens* Lutz. Distrito Federal, Rio de Janeiro, Brazil (L. Whitman).
 " 8. *Wyeomyia (Wyeomyia) lutzi* (Lima). Distrito Federal, Rio de Janeiro, Brazil (L. Whitman).
 " 9. *Phoniomyia edwardsi* Lane and Cerqueira. Paratype slide. Distrito Federal, Rio de Janeiro, Brazil (L. Whitman).
 " 10. *Limatus durhamii* Theobald. Villavicencio, Colombia (L. E. Rozeboom). Specimen in collection of School of Hygiene and Public Health, Johns Hopkins University.
 " 11. *Topomyia barbatus* Baisas. Tacloban, Leyte Island, Philippines (H. R. Roberts). Ex abaca axil. Specimen in collection of Academy of Natural Sciences of Philadelphia.
 " 12. *Harpagomyia genurostris* (Leicester). Calotons (Basey River, Basey Municipality), Samar Island, Philippines (M. J. MacMillan). Ex taro axil.

Culicini: Uranotaenia Group

- " 13. *Hodgesia spoliata* Edwards. Lake Sentani, Hollandia, Dutch New Guinea (L. E. Rozeboom). Ex open swamp.
 " 14. *Zeugomyia lautoni* Baisas. Barugwan River, Tacloban, Leyte Island, Philippines (H. R. Roberts). Ex water in large dead leaves. Specimen in collection of Academy of Natural Sciences of Philadelphia.
 " 15. *Uranotaenia argyrotarsis* Leicester. Group *Uranotaenia*. Irahuan River Valley, Palawan Island, Philippines (J. L. Laffoon). Ex ground pool.
 " 16. *Uranotaenia nigerrima* Taylor. Group *Pseudoficalbia*. Lake Sentani, Hollandia, Dutch New Guinea (K. L. Knight). Ex fallen sago palm frond.

Culicini: Culiseta-Mansonia Group

- “ 17. *Culiseta (Culiseta) incidens* (Thomson). California.
- “ 18. *Orthopodomyia mcgregori* (Banks). Group *Orthopodomyia*. Irahuan River Valley, Palawan Island, Philippines (D. R. Johnson). Ex treehole.
- “ 19. *Ficalbia (Etorleptomyia) elegans* (Taylor). Guadalcanal Island, Solomons (L. E. Rozeboom). Ex wooded swamp.
- “ 20. *Aedeomyia catasticta* Knab. Iwahig, Palawan Island, Philippines (J. L. Laffoon). Ex irrigation reservoir.
- “ 21. *Mansonia (Coquillettidia) xanthogaster* (Edwards). Brigstocke Point, Espiritu Santo Island, New Hebrides (L. E. Rozeboom). Ex open swamp.
- “ 22. *Mansonia (Mansonioides) uniformis* (Theobald). Tacloban, Leyte Island, Philippines (K. L. Knight). Ex open swamp.

Culicini: Aedes Group

- “ 23. *Psorophora (Psorophora) ciliata* (Fabricius). Ithaca, N. Y. (O. A. Johannsen).
- “ 24. *Opifex fuscus* Hutton. Wellington, New Zealand (G. Hudson).
- “ 25. *Aedes (Mucidus) ferinus* Knight. Holotype slide. San Ramon (Penal Farm), City of Zamboanga Province, Mindanao Island, Philippines (J. L. Laffoon, K. L. Knight). Ex ground pool.
- “ 26. *Haemagogus (Haemagogus) capricornii* Lutz. Serra da Cantareira, San Paulo, Brazil (Lerio Gomes).
- “ 27. *Eretmapodites leucopus productus* Edwards. Bwamba, Uganda (A. J. Haddow).
- “ 28. *Armigeres (Armigeres) malayi* (Theobald). Ducong (Basey River, Basey Municipality), Samar Island, Philippines (M. J. MacMillan). Ex coconut shell.

Culicini: Culex Group

- “ 29. *Culex (Lutzia) halifaxii* Theobald. Sohoton Springs (Basey River, Basey Municipality), Samar Island, Philippines (K. L. Knight). Ex rock pool.
- “ 30. *Deinocerites spanius* (Dyar and Knab). Group *C-Dinamamesus*. Brownsville, Texas (H. R. Dodge). Ex crab hole.

Cephalothoracic Figures.

- Figure 31. *Anopheles (Myzomia) farauti* Laveran. Espiritu Santo Island, New Hebrides (K. L. Knight).
- “ 32. *Culex binigrolineatus* Knight and Rozeboom. Lake Sentani, Hollandia, Dutch New Guinea (K. L. Knight). Ex sago palm axil.
- “ 33. *Aedes (Finlaya) niveus* (Ludlow). Olongapo (Subic Bay), Zambales Providence, Luzon Island, Philippines (L. E. Rozeboom). Ex tree hole.
- “ 34. *Megarhinus horei* Gordon and Evans. Group *Megarhinus*. Yurimena, Colombia (M. Bates, L. E. Rozeboom). Ex axil of Ravenala palm. Specimen in collection of School of Hygiene and Public Health, Johns Hopkins University.
- “ 35. *Uranotaenia geometrica* Theobald. Group *Uranotaenia*. Villavicencio, Colombia (L. E. Rozeboom). Specimen in collection of School of Hygiene and Public Health, Johns Hopkins University.

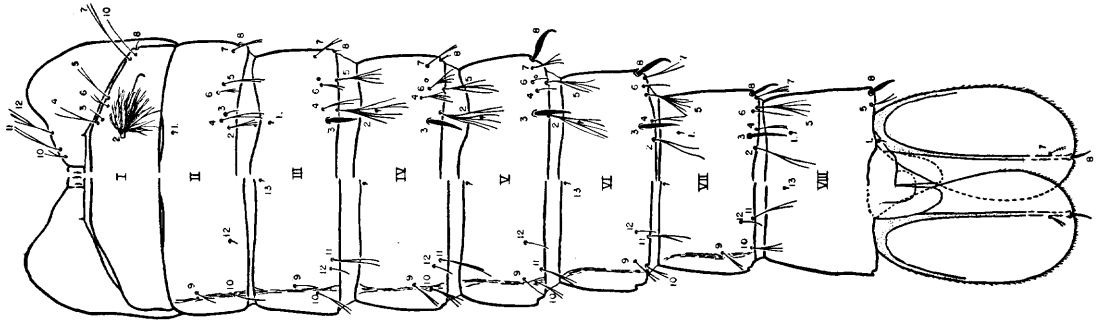

1. CHAGASIA

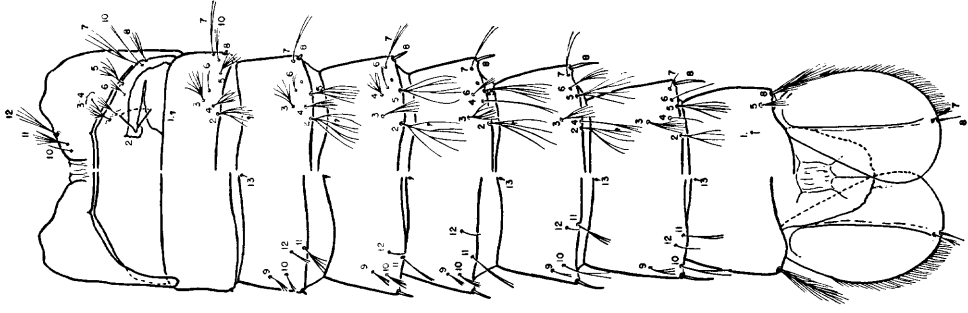

2. BIRONELLA

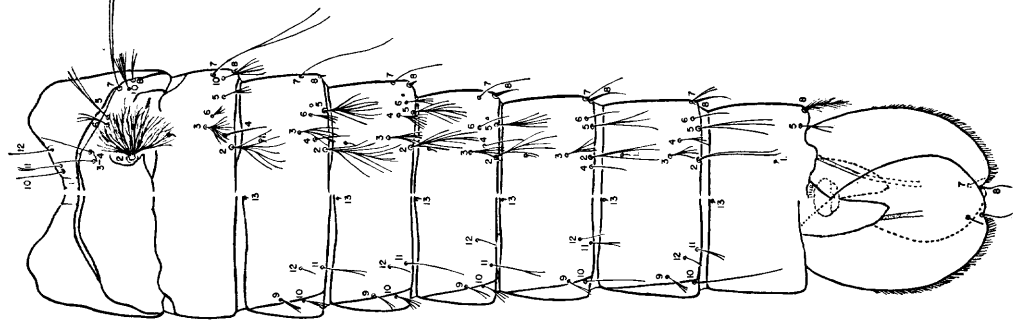

3. ANOPHELES

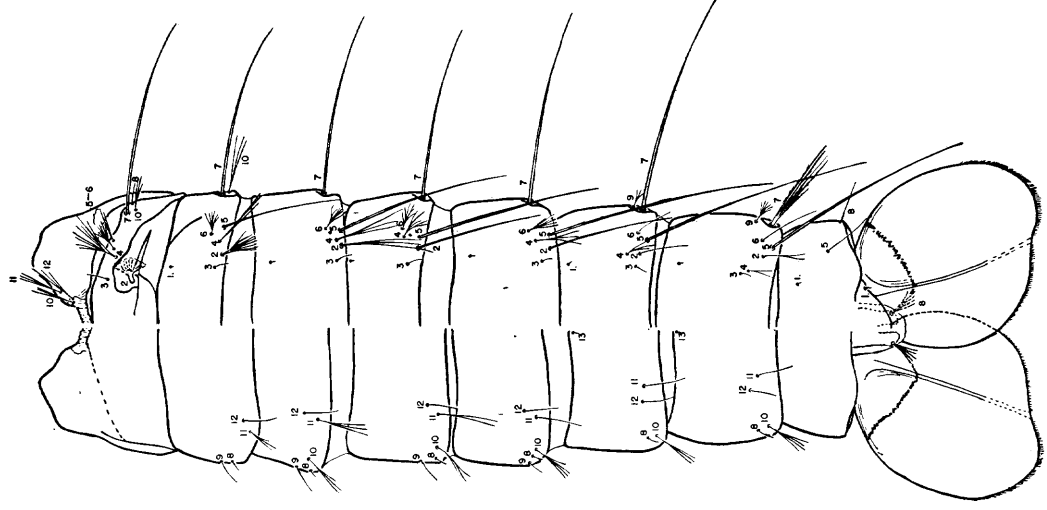

4. MEGARHINUS

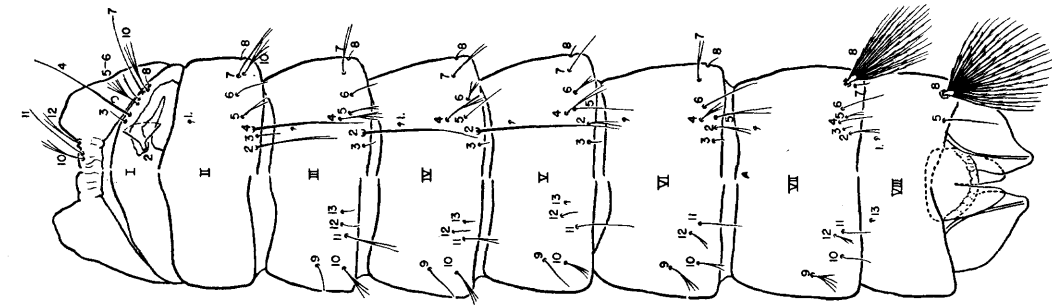

5. TRICHOPROSON

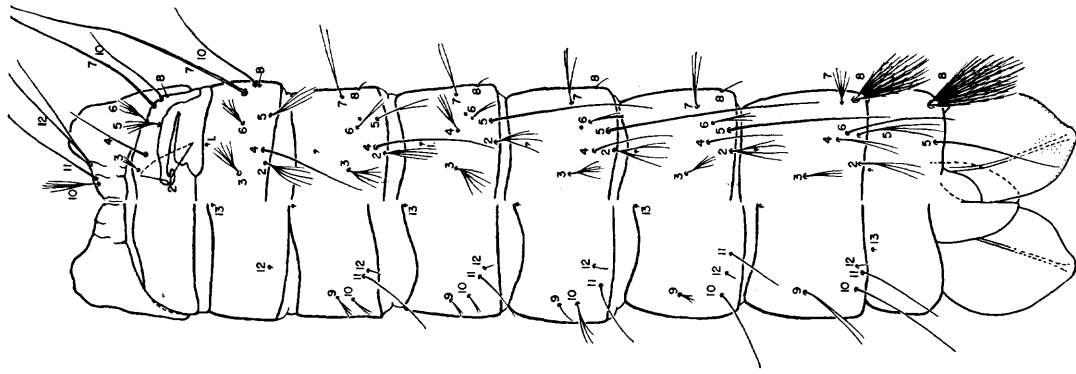

6. TRIPTEROIDES

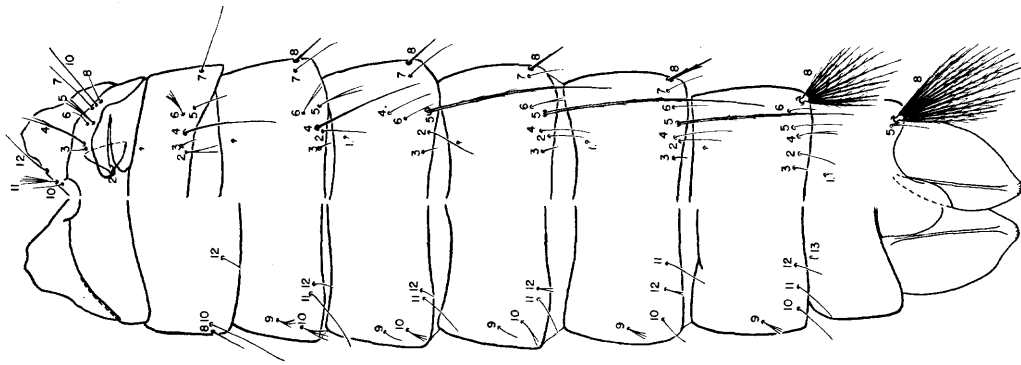

7. SABETHES

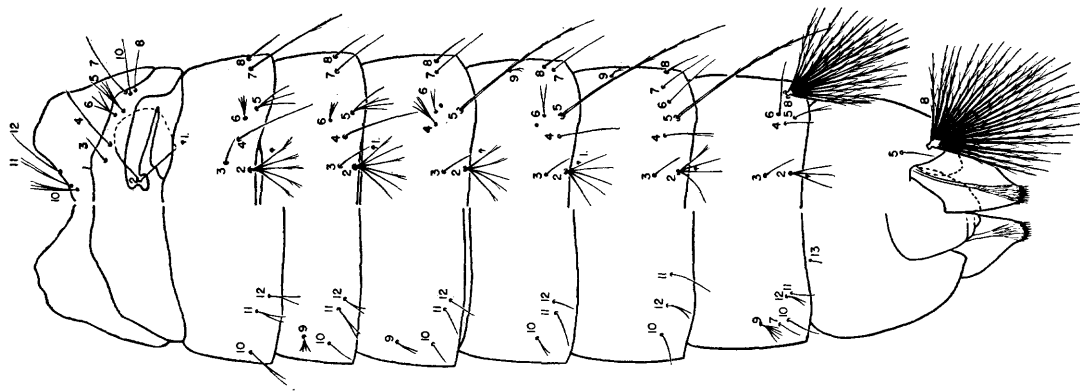

8. WYEOMYIA

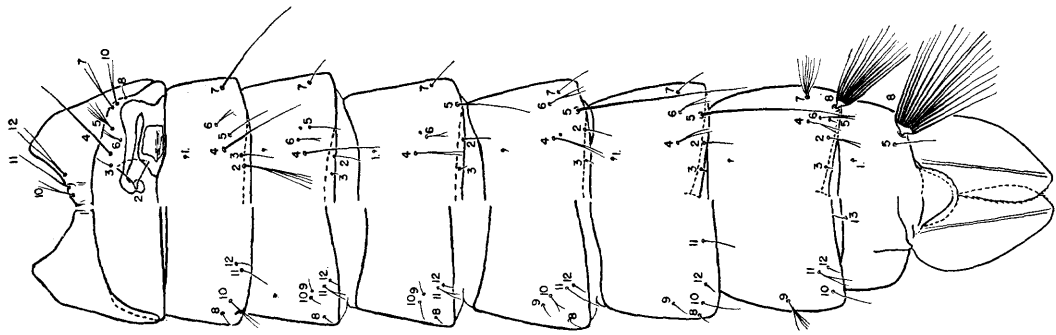

12. HARPAGOMYIA

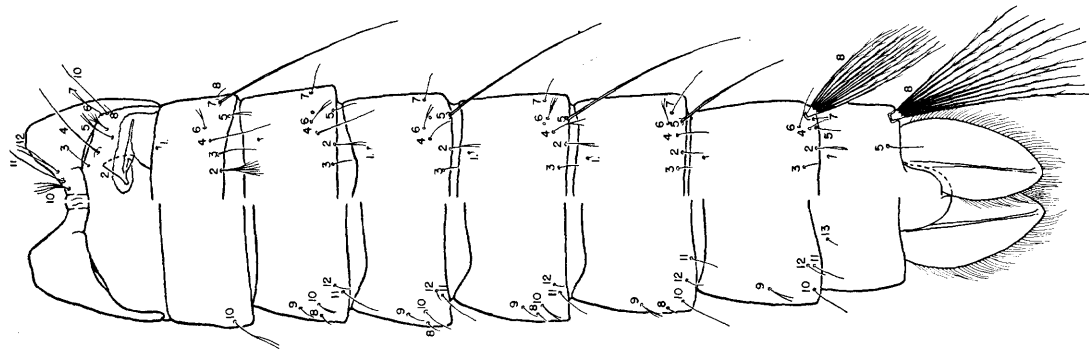

11. TOPOMYIA

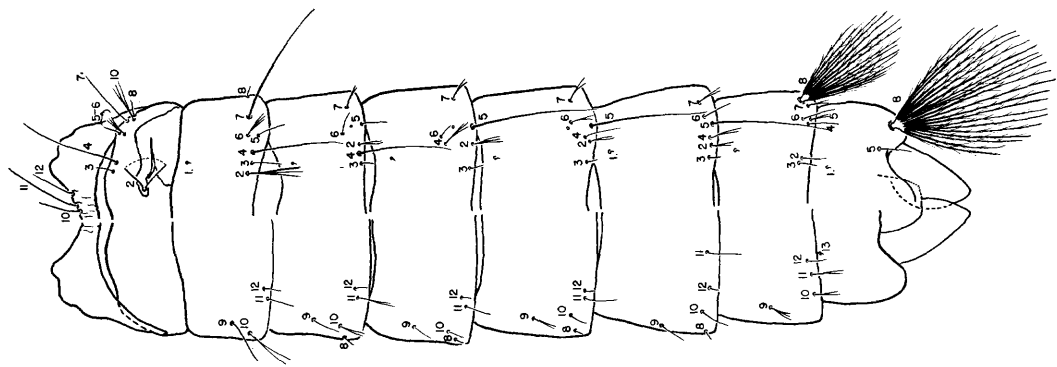

10. LIMATUS

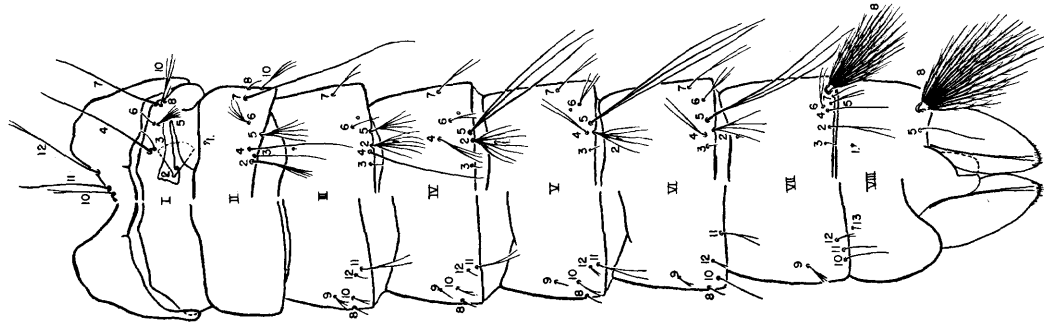

9. PHONIOMYIA

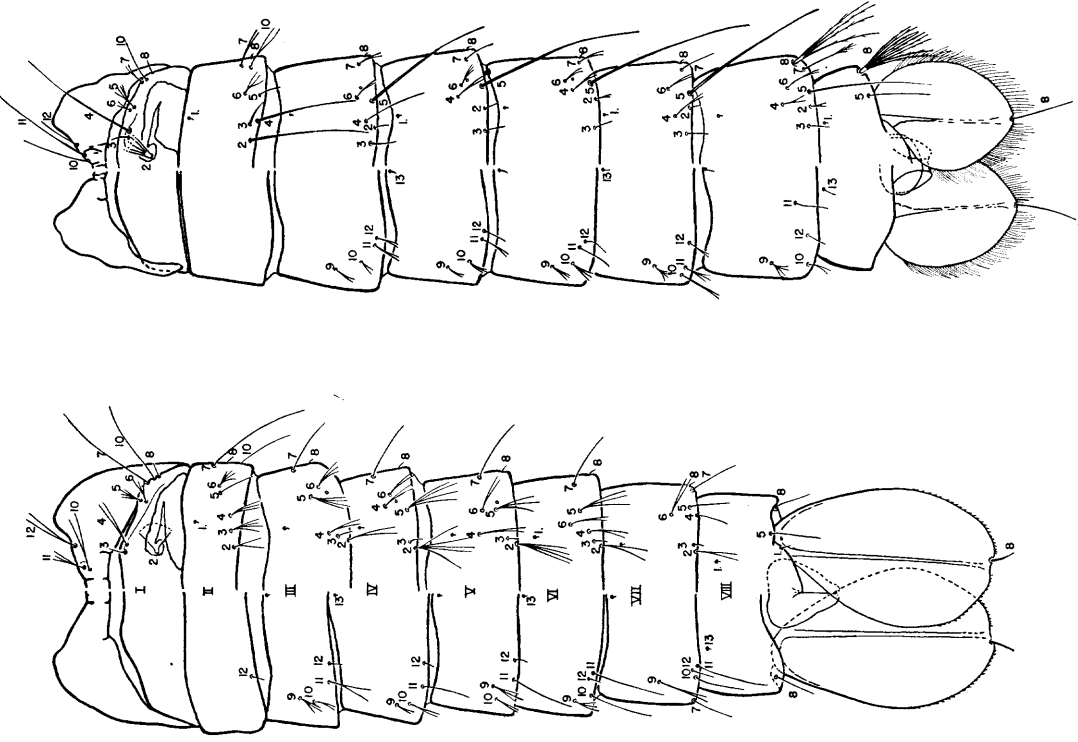

13. HODGESIA

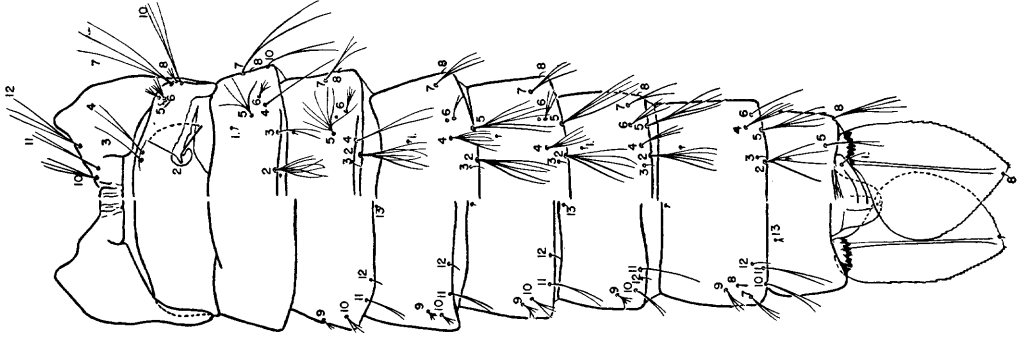

15. URANOTAENIA (URAN)

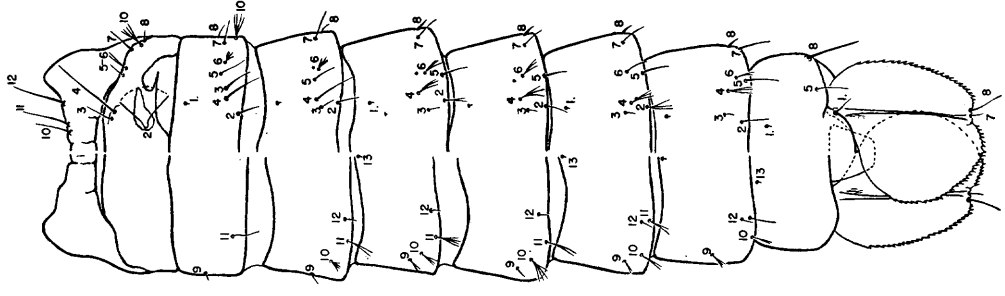

16. URANOTAENIA (PSEUDOFICALBIA)

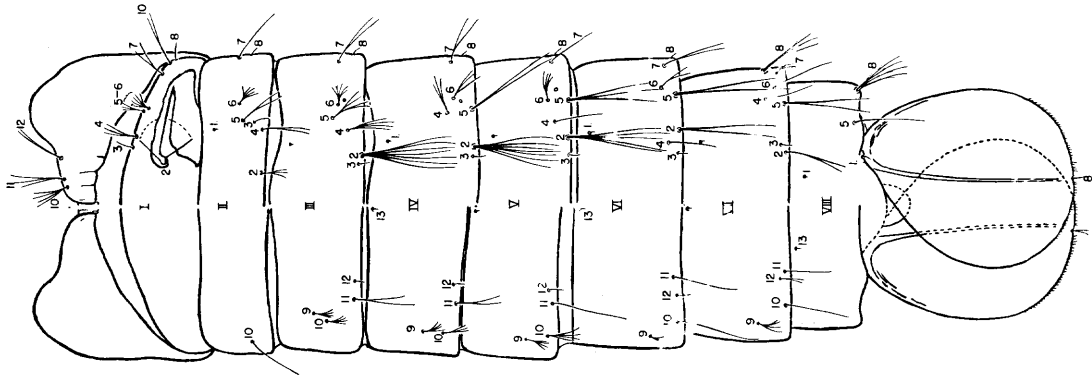

17. CULISETA

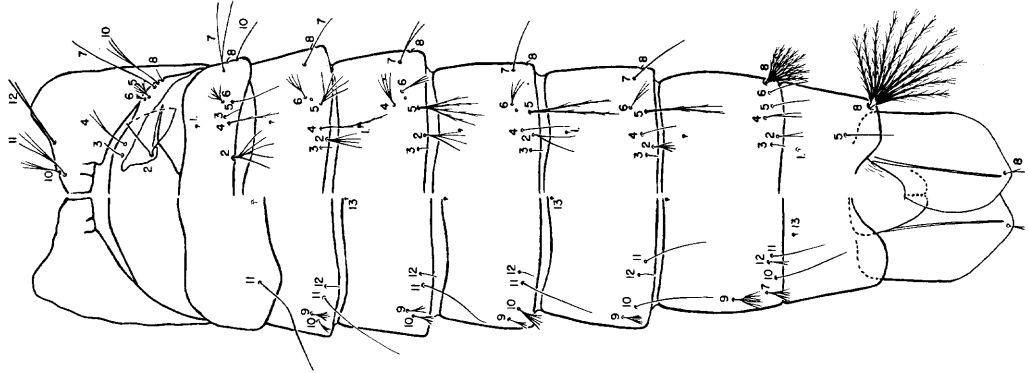

18. ORTHOPODOMYSIA

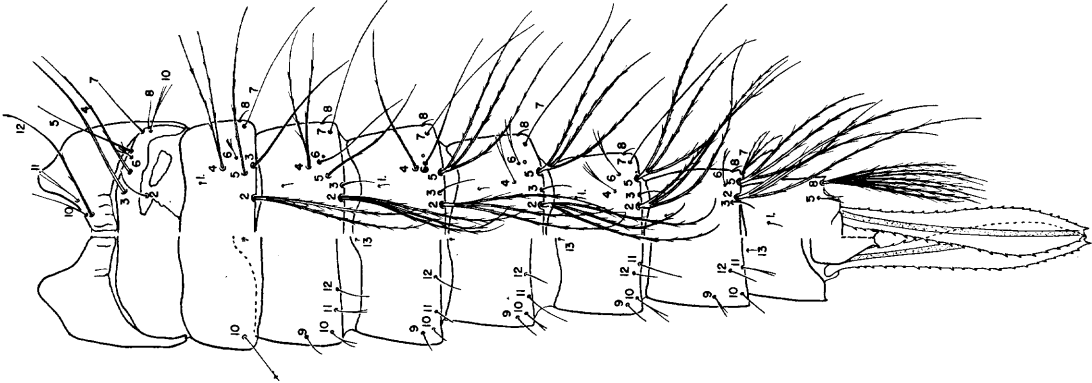

19. FICALBIA

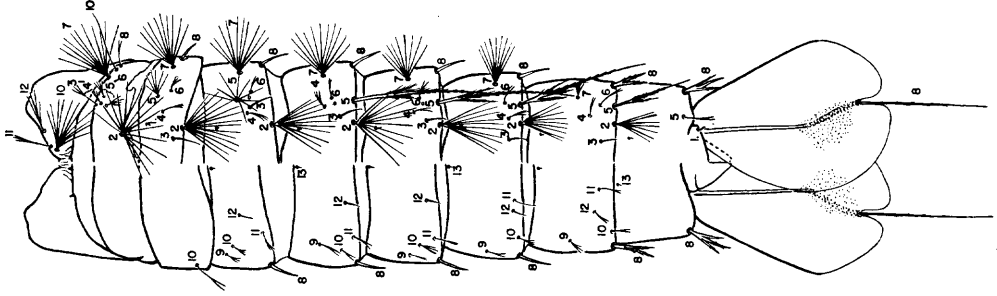

20. AEDEOMYIA

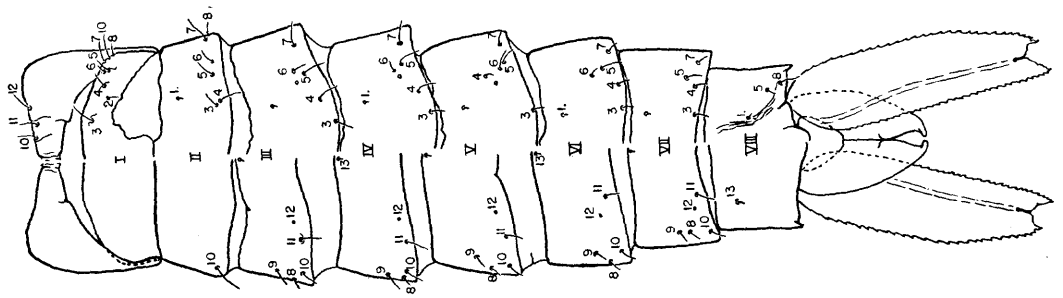

21. MANSONIA (COQ.)

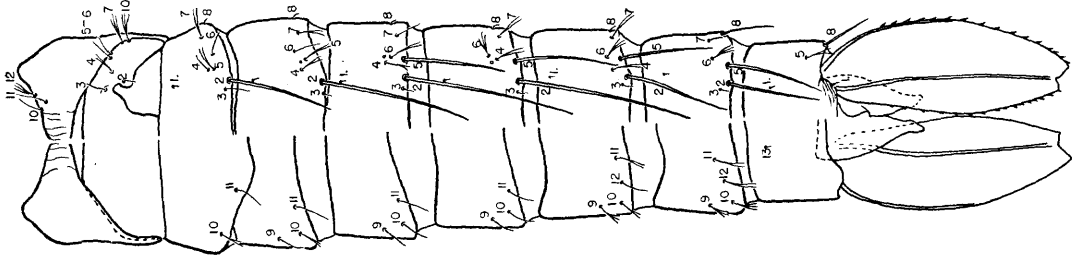

22. MANSONIA (MANSONIOIDES)

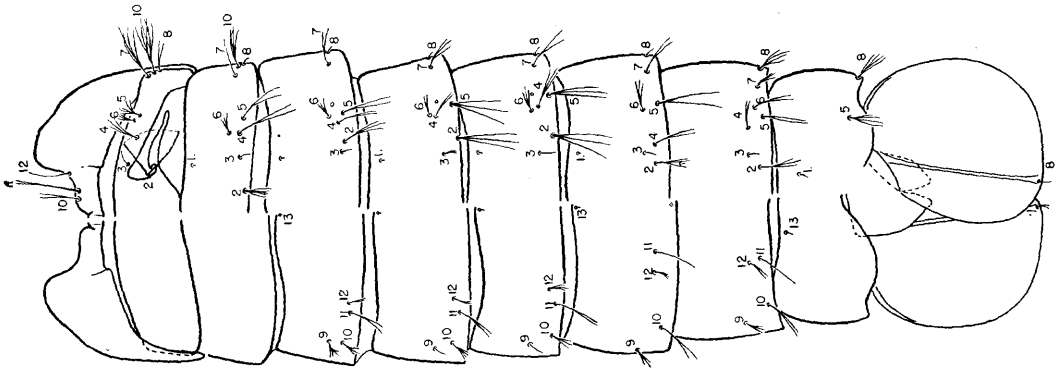

23. PSOROPHORA

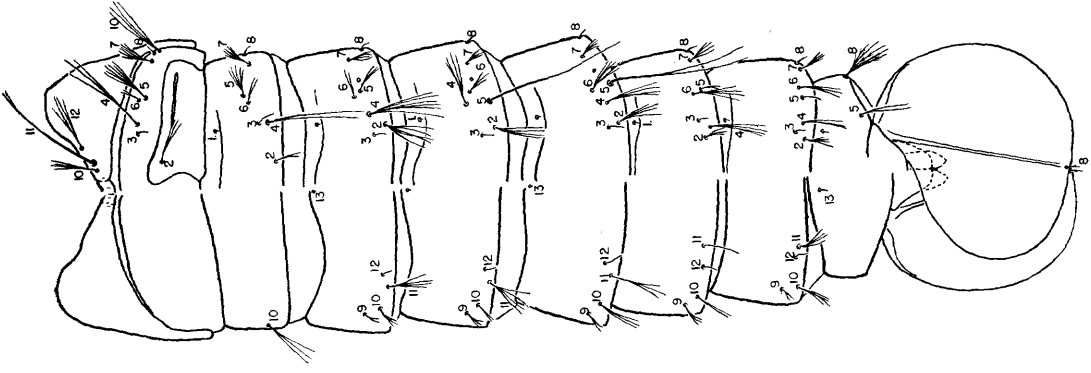

24. OPIFEX

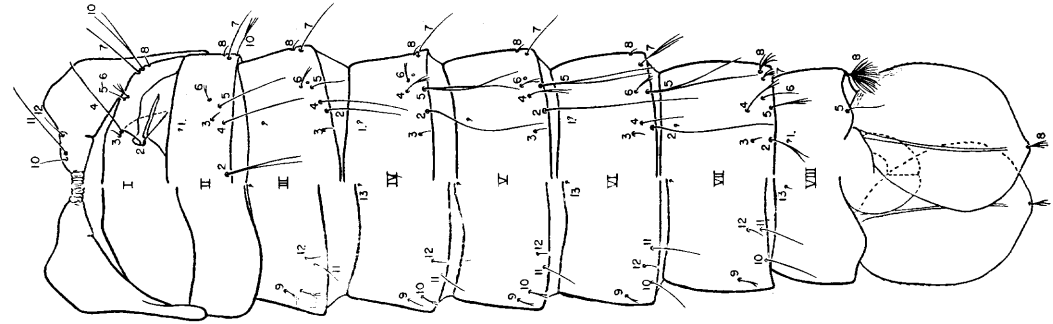

25. AEDS

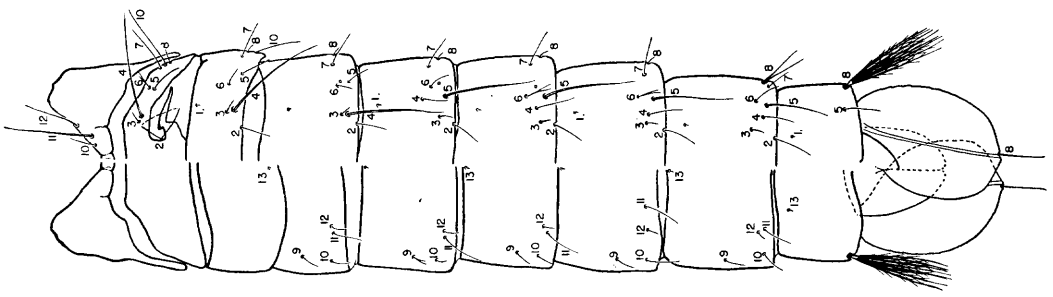

26. HAEMAGOGUS

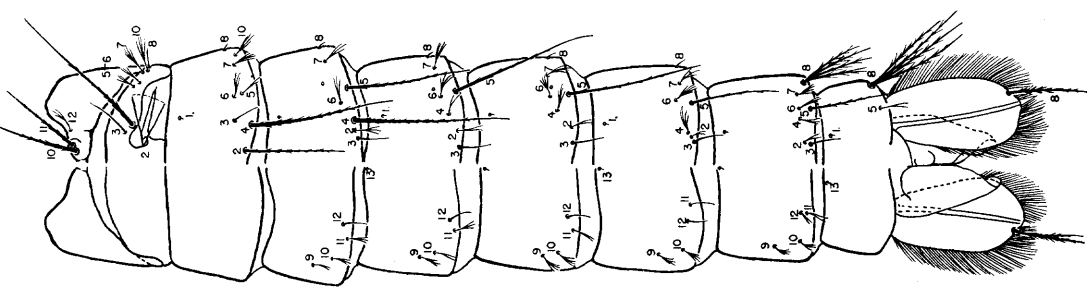

27. ERETMAPODITES

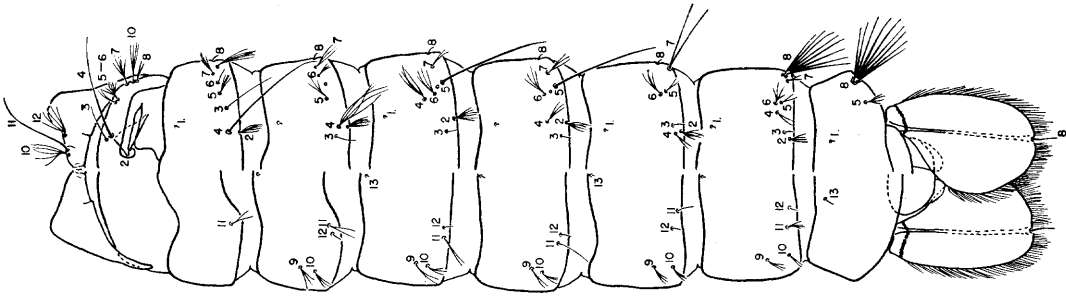

28. ARMIGERES

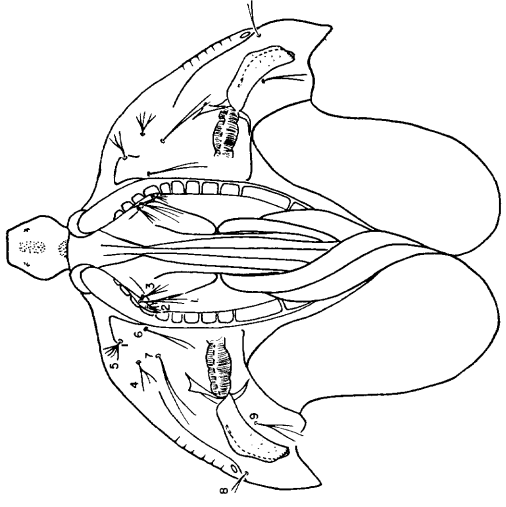
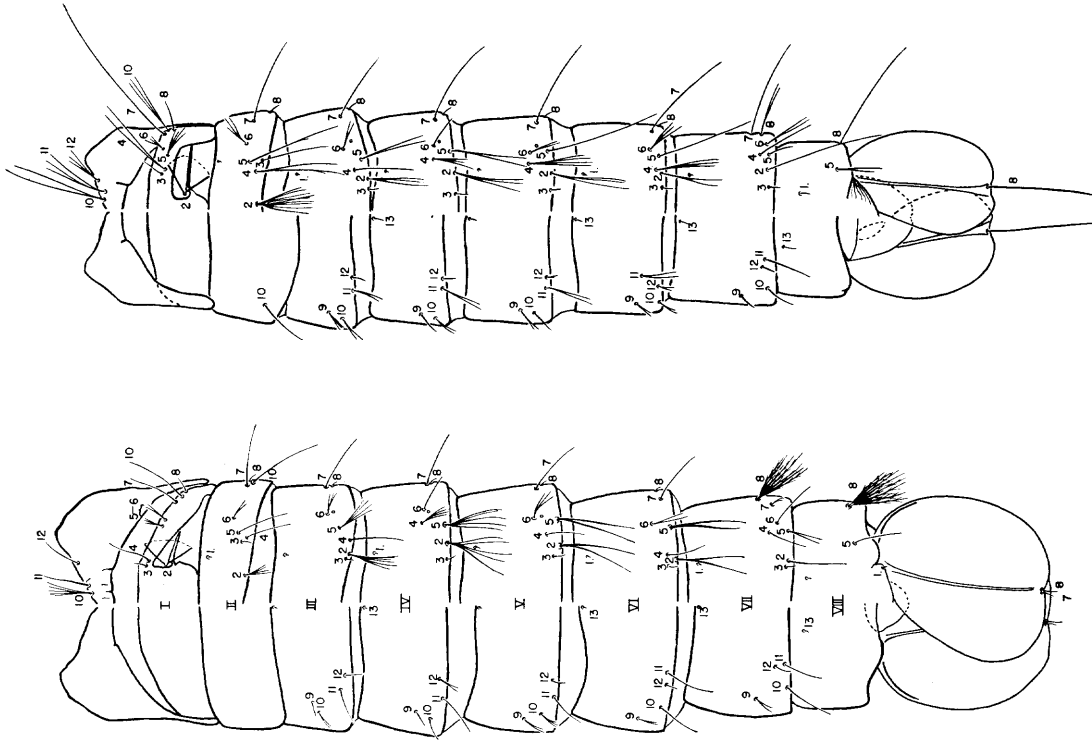

31. ANOPHELES

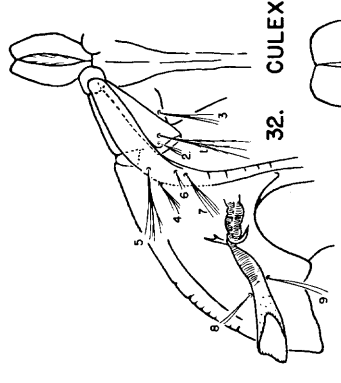

32. CULEX

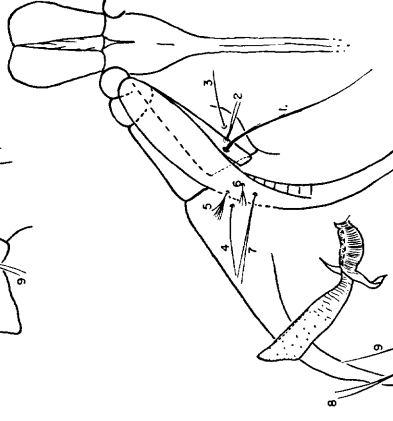

34. MEGARHINUS

