



**NAVAL
POSTGRADUATE
SCHOOL**

MONTEREY, CALIFORNIA

THESIS

**CVN 68 CLASS DISPLACEMENT CONCERNS; DEALING
WITH THE DIFFERENCES BETWEEN THE MODELED
AND ACTUAL DISPLACEMENTS**

by

Clinton P. Hoskins

September 2009

Thesis Co-Advisors:

Charles Calvano
Clifford Whitcomb

Approved for public release; distribution is unlimited

THIS PAGE INTENTIONALLY LEFT BLANK

REPORT DOCUMENTATION PAGE			<i>Form Approved OMB No. 0704-0188</i>	
Public reporting burden for this collection of information is estimated to average 1 hour per response, including the time for reviewing instruction, searching existing data sources, gathering and maintaining the data needed, and completing and reviewing the collection of information. Send comments regarding this burden estimate or any other aspect of this collection of information, including suggestions for reducing this burden, to Washington headquarters Services, Directorate for Information Operations and Reports, 1215 Jefferson Davis Highway, Suite 1204, Arlington, VA 22202-4302, and to the Office of Management and Budget, Paperwork Reduction Project (0704-0188) Washington DC 20503.				
1. AGENCY USE ONLY (Leave blank)		2. REPORT DATE September 2009	3. REPORT TYPE AND DATES COVERED Master's Thesis	
4. TITLE AND SUBTITLE CVN 68 Class Displacement Concerns; Dealing with the Differences between the Modeled and Actual Displacements			5. FUNDING NUMBERS	
6. AUTHOR(S) Clinton P. Hoskins				
7. PERFORMING ORGANIZATION NAME(S) AND ADDRESS(ES) Naval Postgraduate School Monterey, CA 93943-5000			8. PERFORMING ORGANIZATION REPORT NUMBER	
9. SPONSORING /MONITORING AGENCY NAME(S) AND ADDRESS(ES) N/A			10. SPONSORING/MONITORING AGENCY REPORT NUMBER	
11. SUPPLEMENTARY NOTES The views expressed in this thesis are those of the author and do not reflect the official policy or position of the Department of Defense or the U.S. Government.				
12a. DISTRIBUTION / AVAILABILITY STATEMENT Approved for public release; distribution is unlimited			12b. DISTRIBUTION CODE	
13. ABSTRACT (maximum 200 words) The purpose of this thesis is to determine whether or not CVN 68 class aircraft carriers are actually exceeding displacement limits based on NAVSEA projections. The NAVSEA projections are based on commissioning displacement plus any weight added to the ship during subsequent availabilities. The NAVSEA data was augmented with historic displacement values collected from all commissioned CVN 68 class aircraft carriers. Analysis reveals that the NAVSEA projections are predicting the carrier's displacement at ~4,500LT heavier than what is being reported by the ships. The result is a recommendation to conduct an Actual Operating Conditions (AOC) Displacement Check in order to update the NAVSEA displacement projections. By doing so, maintenance associated with weight removal will be minimized, a potential cost saving will be seen, and restrictions placed on ship maintainers will be reduced because a realistic operating condition will be known.				
14. SUBJECT TERMS Naval Architecture, Aircraft Carrier Displacement Models			15. NUMBER OF PAGES 93	
			16. PRICE CODE	
17. SECURITY CLASSIFICATION OF REPORT Unclassified	18. SECURITY CLASSIFICATION OF THIS PAGE Unclassified	19. SECURITY CLASSIFICATION OF ABSTRACT Unclassified	20. LIMITATION OF ABSTRACT UU	

THIS PAGE INTENTIONALLY LEFT BLANK

Approved for public release; distribution is unlimited

**CVN 68 CLASS DISPLACEMENT CONCERNS; DEALING WITH THE
DIFFERENCES BETWEEN THE MODELED AND ACTUAL DISPLACEMENTS**

Clinton P. Hoskins
Lieutenant, United States Navy
B.S., University of Colorado at Colorado Springs, 2000

Submitted in partial fulfillment of the
requirements for the degree of

MASTER OF SCIENCE IN SYSTEMS ENGINEERING

from the

**NAVAL POSTGRADUATE SCHOOL
September 2009**

Author: Clinton P. Hoskins

Approved by: Charles Calvano
Co-Advisor

Clifford Whitcomb
Co-Advisor

David H. Olwell
Chairman, Department of Systems Engineering

THIS PAGE INTENTIONALLY LEFT BLANK

ABSTRACT

The purpose of this thesis is to determine whether or not CVN 68 class aircraft carriers are actually exceeding displacement limits based on NAVSEA projections. The NAVSEA projections are based on commissioning displacement plus any weight added to the ship during subsequent availabilities. The NAVSEA data was augmented with historic displacement values collected from all commissioned CVN 68 class aircraft carriers. Analysis reveals that the NAVSEA projections are predicting the carrier's displacement at ~4,500LT heavier than what is being reported by the ships. The result is a recommendation to conduct an Actual Operating Conditions (AOC) Displacement Check in order to update the NAVSEA displacement projections. By doing so, maintenance associated with weight removal will be minimized, a potential cost saving will be seen, and restrictions placed on ship maintainers will be reduced because a realistic operating condition will be known.

THIS PAGE INTENTIONALLY LEFT BLANK

TABLE OF CONTENTS

I.	INTRODUCTION.....	1
A.	BACKGROUND	1
B.	PURPOSE.....	6
C.	RESEARCH TOPICS	6
D.	BENEFIT OF STUDY	7
E.	SCOPE AND METHODOLOGY	7
F.	CHAPTER SUMMARY.....	8
II.	DISPLACEMENT REVIEW.....	9
A.	INTRODUCTION.....	9
B.	DETERMINING A SHIP’S DISPLACEMENT	11
	1. Basic Displacement and Draft Determinations	11
	2. Ship’s Draft Marks	13
	3. Draft/Displacement Chart.....	14
C.	DISPLACEMENT LIMITS.....	20
D.	CHAPTER SUMMARY.....	24
III.	HISTORICAL TRENDS IN NIMITZ CLASS CVN.....	25
A.	INTRODUCTION.....	25
B.	SERVICE LIFE ALLOWANCES (SLA) FOR WEIGHT AND KG.....	25
C.	SHIP WEIGHT CONDITIONS	26
	1. Lightship	26
	2. Full Load (FL) Condition.....	27
D.	TRENDS, SHIPALTS, AND GROWTH MODEL ADJUSTMENTS FOR ALL CARRIERS.....	30
E.	WEIGHT REMOVAL AND ADJUSTMENTS	38
	1. Paint	38
	2. Weight Removal.....	41
	3. New Construction.....	43
F.	CHAPTER SUMMARY.....	43
IV.	CURRENT TRENDS IN NIMITZ CLASS CVN	45
A.	INTRODUCTION.....	45
B.	UNDERWAY DISPLACEMENT AND DRAFT DETERMINATION....	45
C.	DRAFT REPORTS.....	48
D.	PRESENT CVN DISPLACEMENTS.....	48
E.	RESULTS	58
F.	CHAPTER SUMMARY.....	59
V.	ANALYSIS OF RESULTS, RECOMMENDATIONS, AND CONCLUSION....	61
A.	INTRODUCTION.....	61
B.	ANALYSIS OF RESULTS.....	61
C.	WEIGHT MODEL ADJUSTMENTS	63
D.	RECOMMENDATIONS AND CONCLUSION.....	67

E. CHAPTER SUMMARY.....	69
LIST OF REFERENCES.....	71
INITIAL DISTRIBUTION LIST	73

LIST OF FIGURES

Figure 1.	USS <i>Langley</i> (CV 1) (From Anonymous, 1922)	2
Figure 2.	USS <i>Jupiter</i> (AC 3) (From Anonymous, 1913).....	2
Figure 3.	USS <i>Harry S. Truman</i> (CVN 75) (From Katz, 2005).....	3
Figure 4.	CVN 74 Weight Growth (After Norfolk Naval Shipyard)	5
Figure 5.	Example of a floating body.....	10
Figure 6.	Wooden block in water	12
Figure 7.	Example of aft draft marks on commercial tanker (From Guldner, 2002)	13
Figure 8.	Image of draft marks (From Federation of American Scientists, 2000).....	14
Figure 9.	Ship drawing showing complex shape (From Gillmer and Johnson, 1982)....	15
Figure 10.	Flow of Ship Hull to Sectional Area (After Gillmer and Johnson, 1982)	16
Figure 11.	Figures depicting a Section Area profile (After Comstock, Rossell, and Society of Naval Architects and Marine Engineers (U.S.), 1967).....	17
Figure 12.	A set of Bonjean curves showing a collection of Section Area graphs (After Comstock, Rossell, and Society of Naval Architects and Marine Engineers (U.S.), 1967)	17
Figure 13.	Bonjean curves with an illustrative draft line (After Comstock, Rossell, and Society of Naval Architects and Marine Engineers (U.S.), 1967).....	18
Figure 14.	Bonjean curves and section-area curve (After Comstock, Rossell, and Society of Naval Architects and Marine Engineers (U.S.), 1967).....	18
Figure 15.	Displacement and other curves of form (From Comstock, Rossell, and Society of Naval Architects and Marine Engineers (U.S.), 1967).....	19
Figure 16.	Draft Diagram and Functions of Form (From Surface Warfare Officer School).....	20
Figure 17.	Side Protection System example (From Rawson and Tupper, 1983).....	21
Figure 18.	USS <i>West Virginia</i> (BB 48) with Torpedo Side Protection (additional compartment) (After Gillmer and Johnson, 1982).....	22
Figure 19.	Sketch of torpedo damage to USS <i>West Virginia</i> (BB 48) (From Gillmer and Johnson, 1982)	23
Figure 20.	USS <i>West Virginia</i> (BB 48) with additional torpedo bulge (From Gillmer and Johnson, 1982)	23
Figure 21.	Current Lightship data for CVN 68 class (After Norfolk Naval Shipyard)....	27
Figure 22.	Full Load based on Lightship (After Norfolk Naval Shipyard).....	30
Figure 23.	CVN 68 Predicted Weight Growth (After Norfolk Naval Shipyard)	32
Figure 24.	CVN 69 Predicted Weight Growth (After Norfolk Naval Shipyard)	33
Figure 25.	CVN 70 Predicted Weight Growth (After Norfolk Naval Shipyard)	34
Figure 26.	CVN 71 Predicted Weight Growth (After Norfolk Naval Shipyard)	35
Figure 27.	CVN 72 Predicted Weight Growth (After Norfolk Naval Shipyard)	35
Figure 28.	CVN 73 Predicted Weight Growth (After Norfolk Naval Shipyard)	36
Figure 29.	CVN 74 Predicted Weight Growth (After Norfolk Naval Shipyard)	36
Figure 30.	CVN 75 Predicted Weight Growth.....	37
Figure 31.	CVN 76 Predicted Weight Growth.....	37
Figure 32.	Example hull shape	39

Figure 33.	Daily inport draft report example (From CVN 69, 2008).....	46
Figure 34.	Daily underway draft report example (From CVN 68, 2008)	47
Figure 35.	CVN 68 Actual Displacement Readings.....	50
Figure 36.	CVN 69 Actual Displacement Readings.....	51
Figure 37.	CVN 70 Actual Displacement Readings.....	52
Figure 38.	CVN 71 Actual Displacement Readings.....	53
Figure 39.	CVN 72 Actual Displacement Readings.....	54
Figure 40.	CVN 73 Actual Displacement Readings.....	55
Figure 41.	CVN 74 Actual Displacement Readings.....	56
Figure 42.	CVN 75 Actual Displacement Readings.....	57
Figure 43.	CVN 76 Actual Displacement Readings.....	58
Figure 44.	Pareto chart depicting distribution of variable loads	65
Figure 45.	Cause and Effect diagram	67

LIST OF TABLES

Table 1.	Current CVN Status data (After Corretjer, 2005).....	4
Table 2.	FL load-out elements for NIMITZ class carrier (After Corretjer, 2009a)	29
Table 3.	Carrier FL displacement	29
Table 4.	USS NIMITZ (CVN 68) Lifetime Weight Growth (After: Corretjer, 2009b)	30
Table 5.	USS THEODORE ROOSEVELT (CVN 71) Weight Growth (After Corretjer, 2009b).....	31
Table 6.	Displacement limit and end of life summary	38
Table 7.	Reported Displacement vs. Predicted Displacement for all carriers.....	59
Table 8.	Summary of 24 heaviest points collected CVN 68 class carriers	62
Table 9.	Statistical Summary of Differences Between Peak and Predicted Displacements	63

THIS PAGE INTENTIONALLY LEFT BLANK

LIST OF ACRONYMS AND ABBREVIATIONS

AC	Collier
ACE	Aircraft Elevator
AFS	Aircraft Fueling Station
AIMD	Aircraft Intermediate Maintenance Department
AOC	Actual Operating Conditions
ASSET	Advanced Surface Ship Evaluation Tool
CV	Multi-purpose aircraft carrier
CVN	Multi-purpose aircraft carrier (nuclear propulsion)
FL	Full Load
FOD	Foreign Object Damage
HESS	Helicopter Electrical Startup Stations
KG	Vertical Center of Gravity
LT	Long Ton
mT	Metric Ton
NAVSEA	Naval Sea Systems Command
NSWCCD	Naval Surface Warfare Center Carderock Division
POA&M	Plan of Action and Milestones
RAS	Replenishment at Sea
RCOH	Refueling Complex Overhaul
RPM	Revolutions per Minute
SHIPALT	Ship Alteration
SLA	Service Life Allowances for Weight and KG
SPS	Side Protection System
SWBS	Ship Work Breakdown Structure
VCB	Vertical Center of Buoyancy
VOC	Volatile Organic Compound

THIS PAGE INTENTIONALLY LEFT BLANK

EXECUTIVE SUMMARY

All CVN 68 Class carriers are reported by NAVSEA to be close to, at, or over their displacement/draft limit. Accordingly, they have all been placed in Stability Status 2 (i.e., neither an increase in weight nor a rise of the ship's center of gravity can be accepted), which places bounds on the limits that CVNs will have to operate within to remain safe and effective. In spite of this, programmed availabilities and facts of life continue to increase the weight of these ships because the required weight removal has not been identified and/or funded.

The data collected and analyzed in this thesis shows that the ships' weight growth has been less than NAVSEA has projected.

For the first time, displacement data was gathered from all commissioned CVN 68 class aircraft carriers in an effort to establish the current operating conditions of the carriers in the fleet. This data was then compared to the NAVSEA model that was created based on historical displacement and data gathered during carrier availabilities.

The weight growth projections in the NAVSEA model used to project aircraft carrier displacement are flawed. The most accurate of the projected displacements is 3,651 LT *heavier* than the reported displacement of the ship.

Until an updated Actual Operating Condition (AOC) Displacement Check is performed on an aircraft carrier, ships in this class will continue to be listed as being in Stability Status 2. By completing an AOC check, displacement conditions will be verified and the NAVSEA model can be updated. NAVSEA will then have the information needed to ensure that the stability status of the ships is appropriate and based on accurate data.

THIS PAGE INTENTIONALLY LEFT BLANK

ACKNOWLEDGMENTS

I would like to give my most sincere thanks to my thesis advisors. Prof. Cliff Whitcomb for his meticulous attention to detail and guidance, and Prof. Chuck Calvano for his good nature, vast knowledge, and constant “wire brushing.” My thanks also goes to Wenonah Hlavin for being a sounding board for topics and editing.

I would also like to acknowledge the aid that I received from CDR Jason Lloyd (PMS-312E) for getting me started on this topic and the help throughout the process in getting information (“Be demanding to the point of being unreasonable!”). Also, special thanks go to Carlos Corretjer and John Rosborough at NAVSEA Carderock for their input.

Lastly, and most importantly, I would like to thank my wife, Erin, and three children, Gavin, Carson, and Cambria. I would not be where I am today without their love and constant support, and for that I am eternally grateful.

THIS PAGE INTENTIONALLY LEFT BLANK

I. INTRODUCTION

A. BACKGROUND

The CVN 68 Class aircraft carrier continues to be our nation's on-call asset during times of need because it ensures the Navy's ability to execute all six core capabilities of the Maritime Strategy—forward presence, deterrence, sea control, power projection, maritime security, and humanitarian assistance (Allen, Conway, and Roughead, 2007). These warships are the largest combatants in existence. They act as floating cities, carrying thousands of sailors and scores of aircraft, while executing missions all over the world.

In particular, aircraft carriers directly support naval aviation and that community's ability to play a major part in supporting our National Defense Strategy, by helping deter attacks upon our country, directly and indirectly, through deployments at sea, and through projection of power in the air (Gates, 2008). The idea of developing an aircraft carrier arose from experimenting in the new idea of seaborne aviation, an area some viewed as having unlimited possibilities. Figure 1 shows an image of the first U.S. Navy aircraft carrier, the USS *Langley* (CV-1), which was commissioned 20 March 1922. The *Langley* started out as the USS *Jupiter* (AC-2), shown in Figure 2, a ship designed for the carrying of coal and coal handling, commissioned 7 April 1913. *Jupiter* served on the Mexican Pacific coast during the Vera Cruz crisis of 1914, and then was assigned to Naval Overseas Transportation Service in 1917. She decommissioned on 24 March 1920, was reclassified CV-1 and then re-commissioned as USS *Langley*. Steel framework was added over the main deck utilizing much of the coal-boom support structure for strength, and U.S. Navy carrier aviation was born.

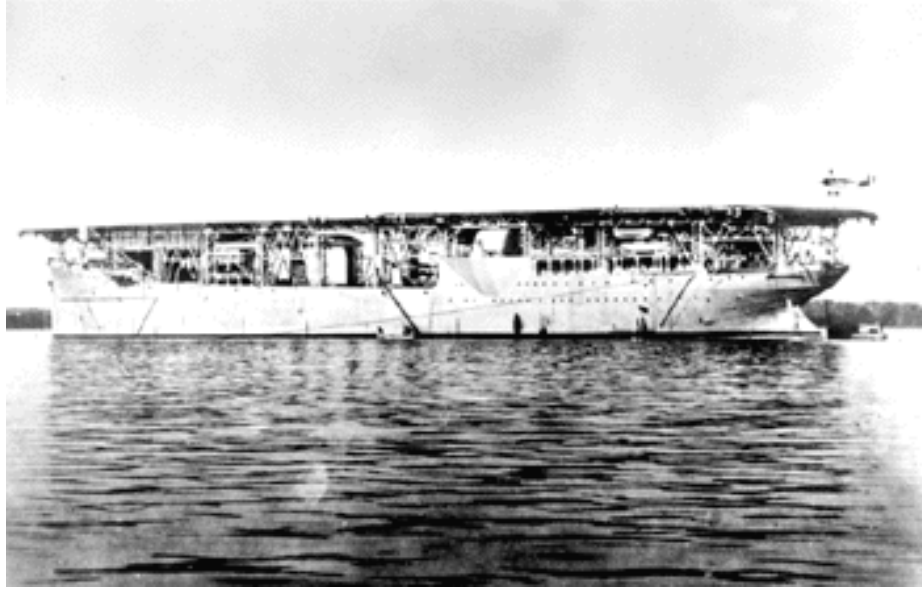

Figure 1. USS *Langley* (CV 1) (From Anonymous, 1922)

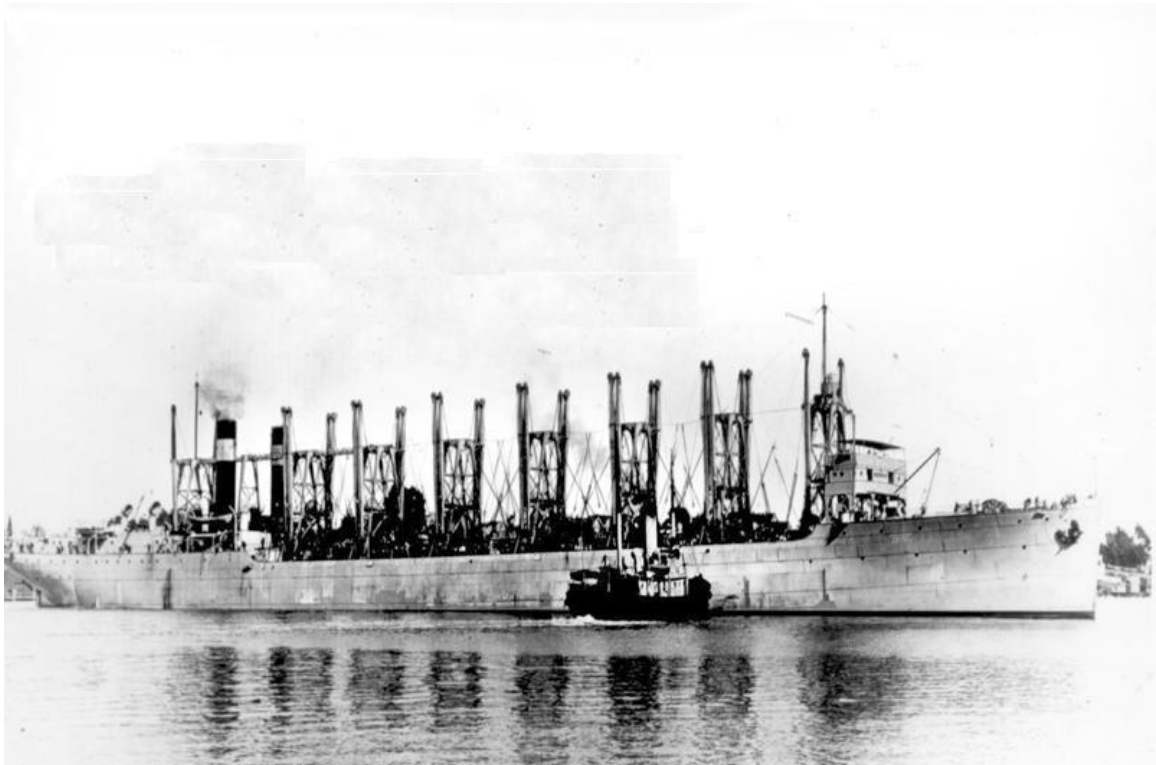

Figure 2. USS *Jupiter* (AC 3) (From Anonymous, 1913)

Historically, the impact and presence of the carriers has been felt in many world conflicts. Some of these conflicts are World War II, Korea, Vietnam, and both Gulf Wars just to name a few. They will continue to be the centerpiece of our Nation's forces that are required to maintain a forward presence throughout the world.



Figure 3. USS *Harry S. Truman* (CVN 75) (From Katz, 2005)

These warships provide unmatched might and power, and with these characteristics come significant operational and structural limits. At the present time, all CVN 68 Class carriers are reported to be close to, at, or over, their displacement/draft limit (Vieira, 2008). With commissioning displacements growing from 93,544 to 103,195 long tons (LT), there is a definite trend of increasing displacements, as well as indications of limits already being exceeded for CVNs 69, 71-73, and 75. Table 1 shows these limits as of January 29, 2009.

Table 1. Current CVN Status data (After Corretjer, 2005)

Ship	Latest Availability	Displacement (LT)	Displacement Limit (LT)
CVN 68	FY04	100,113	103,800
CVN 69	FY99	100,588	103,800
CVN 70	FY02	100,600	103,800
CVN 71	FY04	103,818	103,800
CVN 72	FY03	104,014	103,800
CVN 73	FY03	104,096	103,800
CVN 74	FY03	103,419	103,800
CVN 75	FY03	103,981	103,800
CVN 76	PSA	101,341	104,343

Limit
Exceeded

It should be noted that the Full Load Limit of the CVN 68 class wasn't always 103,800 LT. A displacement of 100,250 LT was the limit for the class before the implementation of a Ship Alteration (SHIPALT) which moved the location of some of the discharge piping (Norfolk Naval Shipyard, 1996). Prior to the SHIPALT the location of the discharge piping was the limiting factor in the Full Load Limit. Following the SHIPALT the new Full Load Limit for the class was increased to 103,800 LT. CVN 76 has a higher displacement limit than the rest of the class due to some design changes below the water line (i.e., the addition of a bulbous bow) that took place following the CVN 75 build.

It is not surprising that a ship's displacement continues to increase over time. This increase can be seen in Figure 4 with CVN 74, which depicts the ship's displacement from the time it was commissioned to projected displacement at decommissioning (with the latest data coming in 2004). Over a ship's lifetime, modernization, upgrades and improvements are introduced which inherently add to the weight.

USS JOHN C. STENNIS (CVN 74) WEIGHT GROWTH

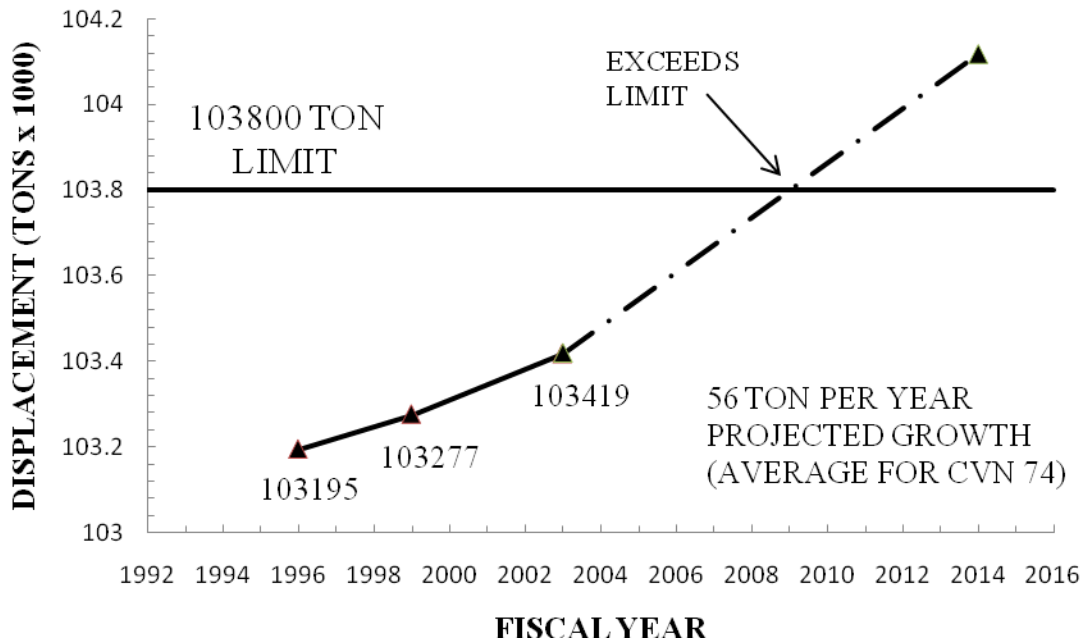

Figure 4. CVN 74 Weight Growth (After Norfolk Naval Shipyard)

All naval warships are expected to operate within naval architectural limits to ensure that the ships maintain certain stability and survivability criteria. The Naval Sea Systems Command (NAVSEA) Weights and Stability Division is charged with tracking a number of different ship data elements to include weight and draft data. With this data the division then advises on each ship’s current status as well as other limitations as they arise. All surface ships are placed into one of four stability categories based on their vertical center of gravity (KG) and limiting drafts. In accordance with the Naval Sea Systems Command (NAVSEAINST 9096.3E, 2005), these are the definitions for the status listing:

- STATUS 1 An increase in weight and a rise of the ship’s center of gravity are acceptable. Added weight and heeling moment resulting from changes will not require any compensation unless the magnitude of the additions is so large as to make the ship approach stability limits.
- STATUS 2 Neither an increase in weight nor a rise of a ship’s center of gravity can be accepted.

- STATUS 3 An increase in the ship's weight is acceptable, but a rise of the ship's center of gravity must be avoided.
- STATUS 4 A rise of the ship's center of gravity is acceptable, but increase in weight must be avoided. Compensation for added weight may be obtained by removal of an equal or greater weight at any level.

Based on current NAVSEA model predictions (like those seen in Figure 4), all aircraft carriers have been placed in STATUS 2, where neither an increase in weight, nor a rise of the ship's center of gravity, can be accepted. In spite of this, programmed availabilities and facts of life continue to increase the weight of these ships because the required weight compensation has not been provided.

It should be pointed out that the term NAVSEA *model* refers to the depiction of data, and using that data to provide indications of future values. In the case of the NAVSEA model, the data is the commissioning displacement plus any known and, in many cases, estimated additions to the weight over the ship's lifetime due to modernizations and upgrades.

B. PURPOSE

The purpose of this thesis is to determine whether CVN 68 class aircraft carrier displacements actually exceed the established limits. It is the intent of this thesis to address the displacement issues currently being faced and to leave any other potential issues, such as the stability, center of gravity, and others, for future studies (for example, Wolfson, 2004).

C. RESEARCH TOPICS

These topics have been developed to provide focus areas and a means of direction throughout the research.

1. What are the architectural and engineering principles behind displacement and draft?
2. What are the known contributing factors for the increase in displacement? What, if any, programs/research is in place to help reduce present weight of the ship?
3. How closely does the current NAVSEA model for predicted displacement follow what the actual draft readings indicate? If there are differences between the two values, what are the possible reasons?

4. Provide possible recommendations, cost estimates, and a Plan of Action and Milestones (POA&M) for additional investigations.

D. BENEFIT OF STUDY

This thesis can act as a guide in developing ship operator guidance showing the effect that changes in displacement have on the ship's performance, especially survivability. It will also act as an indicator as to whether or not actual operating characteristics match up to predicted (estimated) values for draft and displacement.

E. SCOPE AND METHODOLOGY

This thesis focused on a few main themes. First, investigation of the background information that led to the conclusion that a problem is currently faced by all commissioned CVNs today, as a result of their increasing displacement, was addressed. Second, how these problems are affecting CVNs today was studied. Lastly, the operational displacement data was compared to NAVSEA model displacement predictions to determine if a statistically significant difference exists between the two.

An important element for this research was conducting a review of applicable literature and surveys of applicable documentation which outlined the effects of changes in displacement/draft, cost estimation, and data to analyze further degradation in status.

Interviews were conducted during the course of research, and a number of topics were addressed. Questions were framed to gain adequate understanding of the topic at hand, as well as to provide guidance throughout the research. These interviews were conducted with a number of individuals familiar with the CVN 68 Class aircraft carrier and her historic, as well as current issues with stability and displacement. Experts in the fields of naval architecture, marine engineering, acquisition, and program management were interviewed to gather necessary data to analyze the effects on ship capabilities that changes in stability and displacement have had.

The needs of the stakeholders were identified, and key metrics were developed and put in place to ensure these needs were addressed. The most stressing need stemmed from the desire to know what could be done about the ever increasing weight of the current CVN 68 Class and how it would affect the class's capabilities.

Analytical tools, such as Microsoft Excel, S-Plus, and ASSET (Advanced Surface Ship Evaluation Tool), were used to develop and analyze data that is used as a basis for studying the information gathered, and to provide recommendations for additional investigations.

Conclusions were drawn, and recommendations made, for further application. Recommendations are made for further research into the areas of stability, damage control effect, and survivability.

F. CHAPTER SUMMARY

This chapter provided the foundation on which this thesis was built, with an introduction of the topic to include the background, purpose, research questions, benefit of study, and methodology.

II. DISPLACEMENT REVIEW

A. INTRODUCTION

Many concepts exist that help define ship displacement. Weight, rigid bodies, equilibrium, and buoyancy are just a few of these concepts. The case of a rigid body in a fluid is a good starting point.

When discussing topics regarding a body in a fluid, Archimedes' Law applies. Archimedes' Law states:

If a body be either wholly or partially immersed in a fluid, the body will experience an upward force equal and opposite to the weight of the fluid displaced by it. (Comstock, Rossell, and Society of Naval Architects and Marine Engineers. (U.S.), 1967)

The upward force described above is known as a buoyant force (F_b). It is also referred to as the buoyancy of the body, or simply as buoyancy.

When applying Archimedes' Principle, there are three cases that occur:

1. $F_g > F_b$ whereby the body will move downward in the water (sink)
2. $F_g = F_b$ whereby the body will float partially submerged as shown in Figure 6
3. $F_g < F_b$ whereby the body will move upward in the water

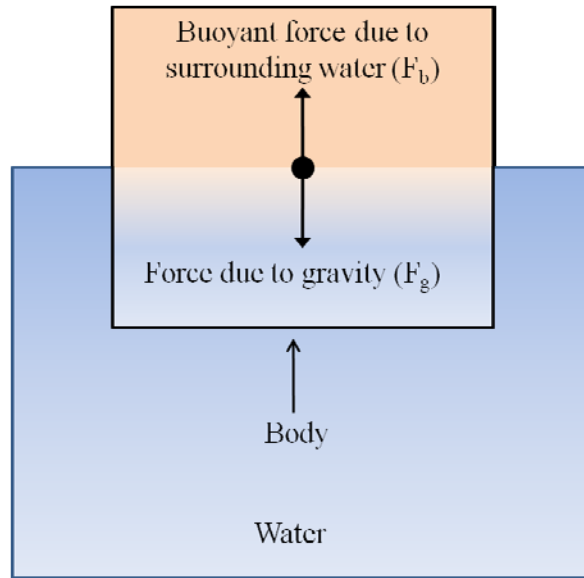

Figure 5. Example of a floating body

It is the second case that is most important for a ship in the water. It has been referred to as a special case of Archimedes' Principle, or the Law of Flotation (Zubaly, 1996). When a body floats in a fluid, the buoyant force (F_b) acting on the body is equal to the gravitational force (F_g) acting on the body.

Now that flotation has been defined, the idea of displacement can be discussed. When referring to a body in water, that body is said to have a displacement equal to the weight of the mass of water that it displaces. In other words, if that body were to be removed from the water, and the void that it left behind was to be filled with water, the weight of the water that would fill the void would be equal to the weight of the body that was removed from the water. When this concept is applied to ships, the *displacement* (Δ) is said to be found, and it is the universal method of describing a ship's weight.

In order to move from knowing the *volume of displacement* (∇) of the water that fills the void left by a ship to the actual weight displacement, a few things need to be taken into account. One of these is the density of the fluid, in this case, the density of water (fresh water or sea water). Density is a physical property of a material that

describes its mass per unit volume. Typical units for density are lbs/in^3 or kg/m^3 . Density allows for the conversion from a known volume to the weight (or mass) of that volume.

Knowing the volume of water and the water density, the weight of the water, and therefore the displacement of the body *in the water*, can be found. The basic equations utilized for finding the displacement of a body are as follows:

$$\Delta = \rho g \nabla \text{ (U.S. Units)} \quad (1.1)$$

$$\Delta_m = \rho \nabla \text{ (SI units)} \quad (1.2)$$

where

Δ = displacement (weight)

Δ_m = displacement (mass)

ρ = density of water

g = acceleration due to gravity

∇ = volume of displacement

Typically, a ship's displacement is defined in terms of tons. In U.S. units, the long ton is used where 1 long ton (LT) = 2,240 pounds (lbs). In SI units, the metric ton is used where 1 metric ton (mT) = 1000 kilograms (kg).

B. DETERMINING A SHIP'S DISPLACEMENT

1. Basic Displacement and Draft Determinations

In describing displacement determinations, a basic wooden block diagram will be used to explain the fundamental concept. This block has dimensions $L \times W \times H$ where L is the length of the block, W is the width of the block, and H is the height of the block.

The block of wood is floating in a body of water. As shown in Figure 6 below, an additional dimension T is used to indicate the draft of the block of wood, or the distance from the bottom of the block to the waterline.

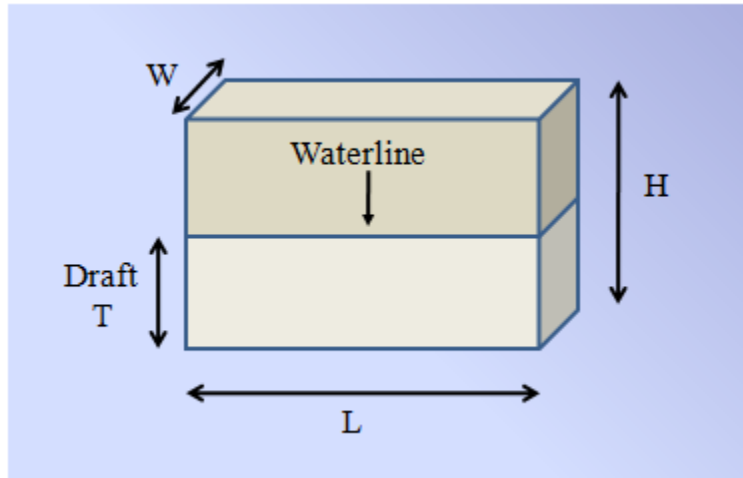

Figure 6. Wooden block in water

As described above using Archimedes' Principle, the weight of the block of wood, or its displacement, is equal to the weight of the volume of the water that it displaces. This means that by finding the volume of the displaced water and mathematically manipulating it using the formulas described previously, the wooden block's displacement can be found. The volume of the displaced water is equal to the volume of the body in the water from the waterline down. Therefore, the displacement of the wooden block in Figure 7 can be found using one of the two following formulas:

$$\Delta = \rho g \nabla = \rho g (L \times W \times T) \text{ (if using U.S. units)}$$

or

$$\Delta_m = \rho \nabla = \rho (L \times W \times T) \text{ (if using SI units)}$$

where

ρ = density of the surrounding water

Based on the method presented, the only things that are required to calculate a ship's displacement are the dimensions of the ship below the waterline. Ship length and

beam (width) are normally known values, as is the gravitational constant g and the density of water ρ . The depth of the ship below the waterline (its draft) is the last unknown quantity and it is found by observing the ship's draft marks.

2. Ship's Draft Marks

The ship's draft is a standard way of indicating the depth of the ship below the surface of the water. Figure 7 below shows an example of draft marks. There are a number of different types of draft marks on a ship. Two common ones are navigational draft marks and calculative draft marks.



Figure 7. Example of aft draft marks on commercial tanker (From Guldner, 2002)

Navigational draft marks are considered the ship's operating drafts and they establish the draft based on the lowest point on the ship. This may be the keel, or anything lying below the keel such as a sonar dome or the rudder.

The calculative draft marks are based purely on the depth of the keel. The keel is considered the baseline for these marks. It is from these draft marks that calculations for displacement and other ship properties for stability and damage control are taken.

A ship typically has two sets of draft marks. Figure 8 shows an example of these drafts marks with one at the bow of the ship, and the other at the stern. There are many things that can be determined from these marks including trim and displacement.



Figure 8. Image of draft marks (From Federation of American Scientists, 2000)

3. Draft/Displacement Chart

Based on the calculations described above, determining a ship's displacement shouldn't be too challenging. Only for wall sided barges for transport does the shape of the ship below the waterline look like that of a simple wooden block. Figure 9 shows an example of how complex the hull shapes can become.

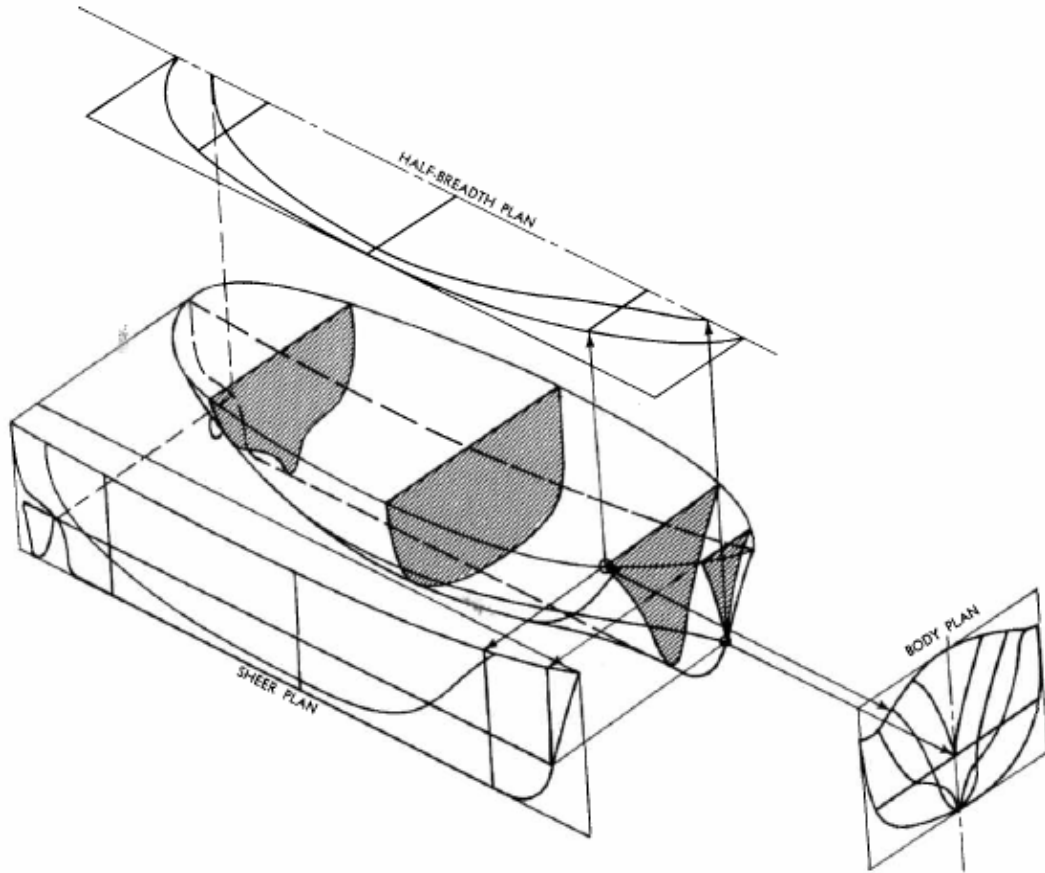

Figure 9. Ship drawing showing complex shape (From Gillmer and Johnson, 1982)

Hull forms of ships are complex by nature. They are designed in such a way to help maximize stability and cargo holds, while at the same time reduce resistance and stress to the structure. As a result of these complex hull shapes determining the volume of displacement is not as straight-forward as it is with the simple block of wood example described earlier.

There are a number of methods that can be used to calculate the volume displacement for a ship. One of these is the use of Bonjean Curves. Bonjean curves are a simple representation of the areas of the transverse (side-to-side) sections (sectional areas) of a ship at varying waterlines (drafts). The development of these curves is illustrated below.

The ship is “divided” into sections called stations, from fore to aft, as seen in Figure 10. These station sections represent a “slice” through the ship. It is the area of these slices that is used to develop the area curves.

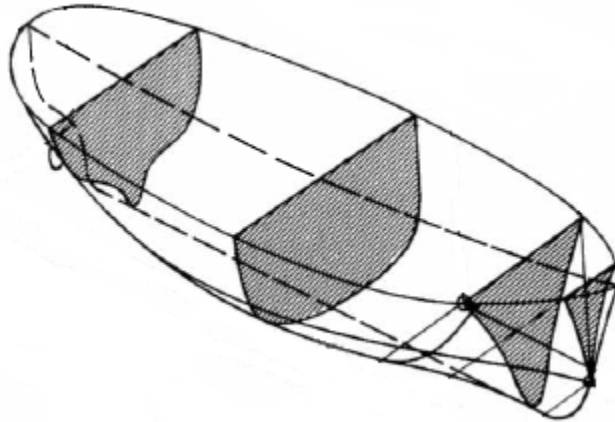

Figure 10. Flow of Ship Hull to Sectional Area (After Gillmer and Johnson, 1982)

The area of each section is then found and plotted for varying waterlines, as depicted in Figure 11. The figure on the left depicts a half section area with two waterlines represented: a green line and a blue line. The total area of the half-section below the green line is found (through rules of integration) and that value is plotted on a graph. The same thing has been done for the blue line. These areas are found for a series of waterlines and their values are plotted, giving a graph like the one seen on the right. Now, with the knowledge of only the waterline, it is possible to find the area of a half section by simply looking at the graph. In order to go from the area of the half section to the area of the whole section, the calculated areas are simply doubled.

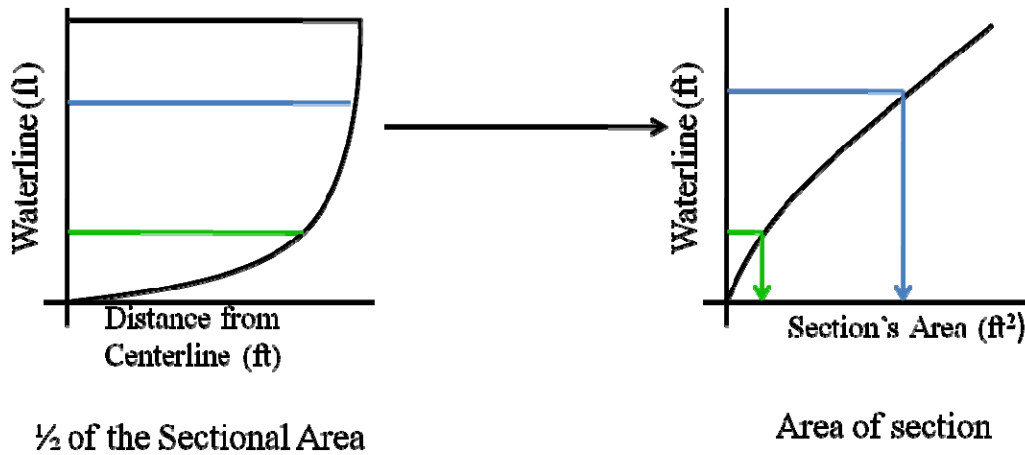

Figure 11. Figures depicting a Section Area profile (After Comstock, Rossell, and Society of Naval Architects and Marine Engineers (U.S.), 1967)

This procedure is done for all of the sections on the ship. These profiles are then put together on one plot, Figure 12. This graph depicts a set of Bonjean curves.

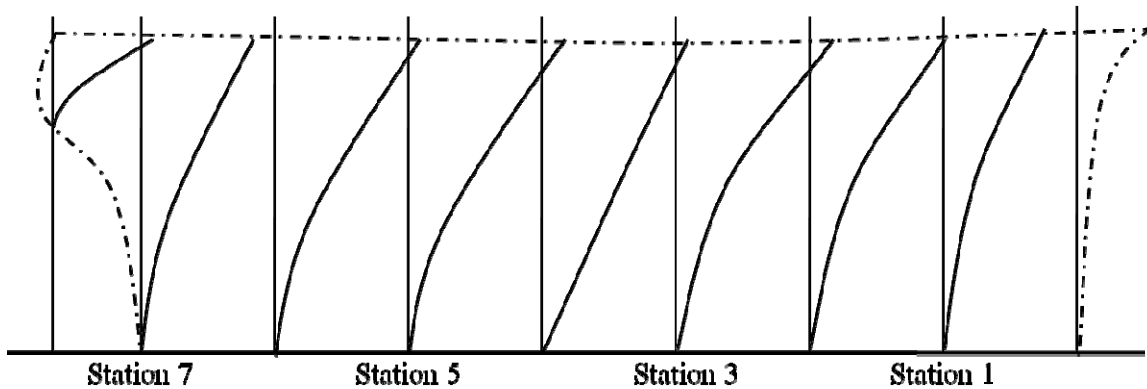

Figure 12. A set of Bonjean curves showing a collection of Section Area graphs (After Comstock, Rossell, and Society of Naval Architects and Marine Engineers (U.S.), 1967)

With the Bonjean curves, it is possible to find a number of things such as the draft at any station on the ship, the longitudinal position of the center of buoyancy, and most importantly the volume of displacement, all for varying positions of the waterline. Figure 13 shows a draft line (the dotted line connecting forward and aft draft) superimposed on the Bonjean curves. Where this line crosses a station line (the vertical line directly above the station name), that section's draft can be read off.

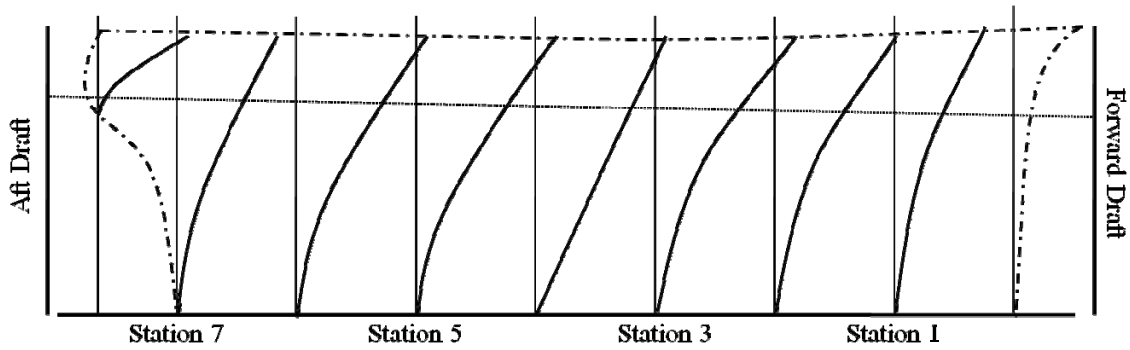

Figure 13. Bonjean curves with an illustrative draft line (After Comstock, Rossell, and Society of Naval Architects and Marine Engineers (U.S.), 1967)

With the draft line in place, a sectional-area curve can also be found. This curve is necessary in determining the volume of displacement. Wherever the draft line crosses a station line, a horizontal line is drawn over to that section's profile line (the red horizontal lines in Figure 14). This intersection represents that section area. (This is the same procedure that was used in Figure 11.) Each section area is then plotted on a graph. With all section areas found and plotted, a line is drawn connecting them. The resulting image is the section area curve (bottom image in Figure 14). The area under this curve is then found. This area represents the ship's volume of displacement for the given draft line.

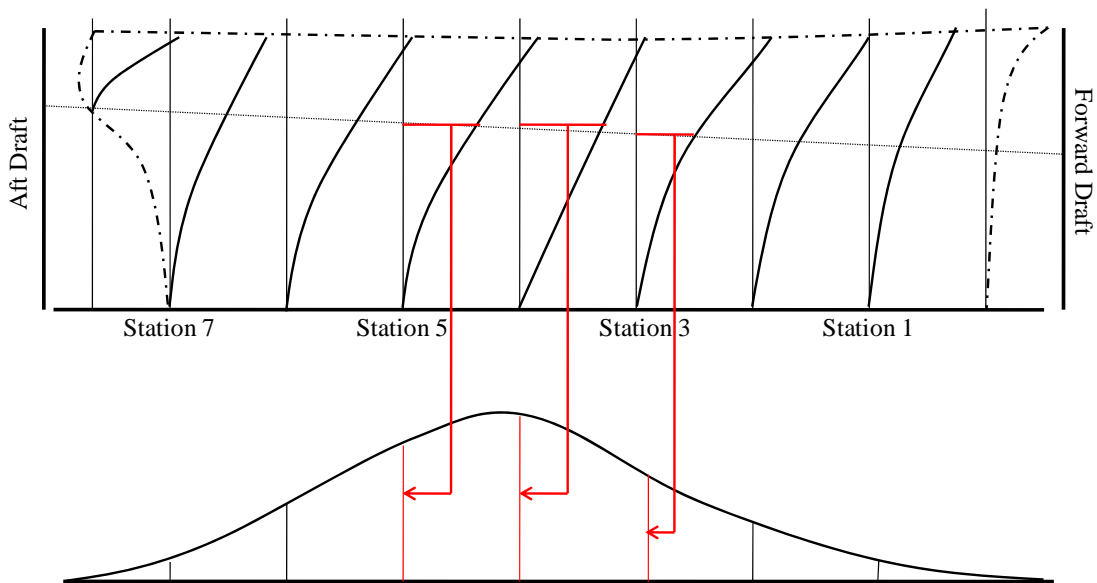

Figure 14. Bonjean curves and section-area curve (After Comstock, Rossell, and Society of Naval Architects and Marine Engineers (U.S.), 1967)

This same procedure is done for varying drafts and trims. Charts and tables, like those seen in Figures 15 and 16, are then created that allow the displacement to be determined with only the knowledge of the forward and aft drafts. These figures have been generated by ship designers and naval architects based on the numerical and computational calculations seen above, and are considered to be adequate.

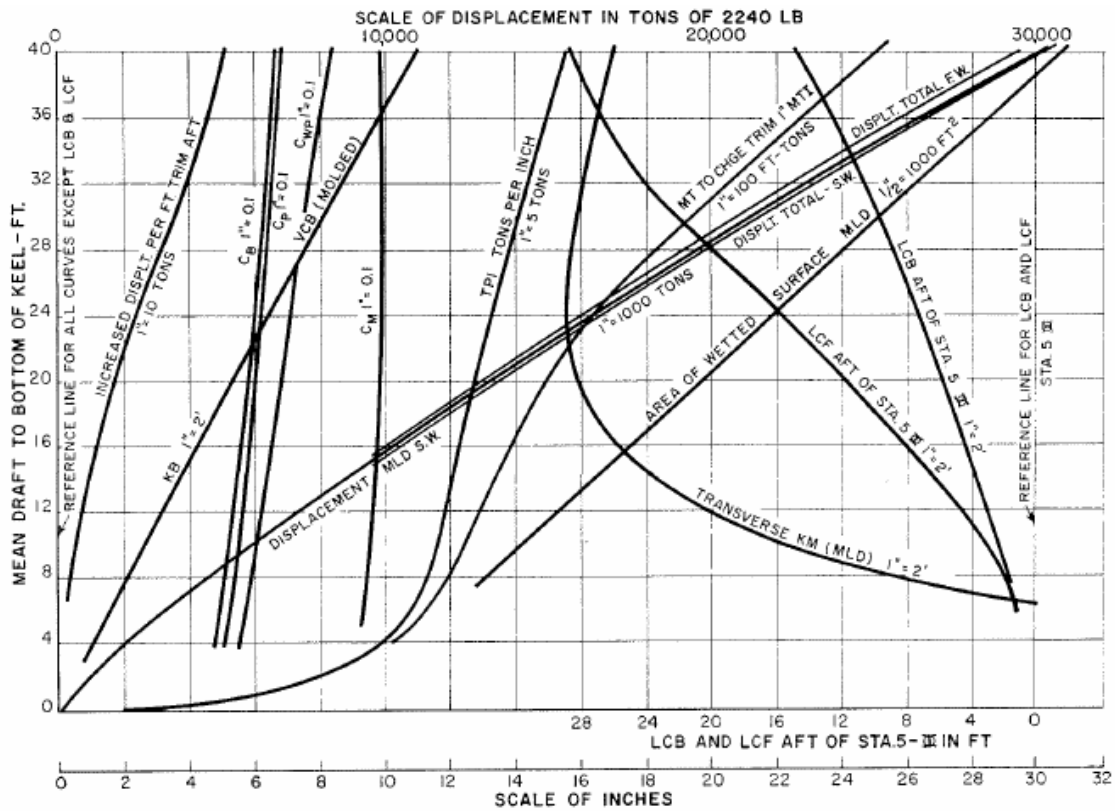

Figure 15. Displacement and other curves of form (From Comstock, Rossell, and Society of Naval Architects and Marine Engineers (U.S.), 1967)

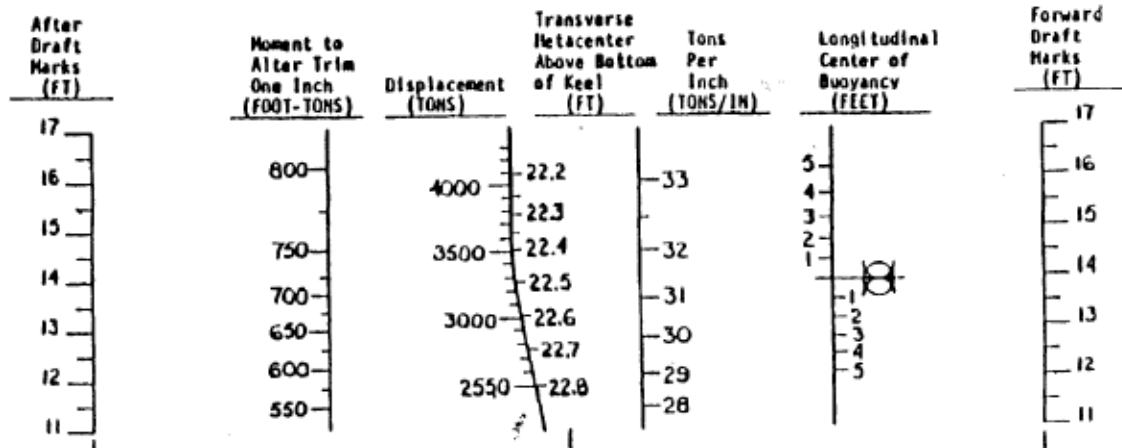

Figure 16. Draft Diagram and Functions of Form (From Surface Warfare Officer School)

Figures like those seen in Figures 15 and 16 are onboard most seagoing vessels and they are used to get engineered estimates for a number of things. Figure 15, for example, allows the user to find the Area of Wetted Surface and the Vertical Center of Buoyancy (VCB), among other things, with only a knowledge of the ship's mean draft (average of fore and aft drafts). Figure 16 is a much simpler plot that allows a number of values to be found with the simple observation of the fore and aft drafts. On a Navy warship, for example, daily readings of the forward and aft draft are taken. These two values are plotted on a chart (like the one seen in Figure 16) and a line is drawn connecting the two values. Where this line crosses the displacement curve indicates what the present displacement of the ship is. This reading is then logged as the ship's displacement for that day.

C. DISPLACEMENT LIMITS

A ship's displacement limit is a vital piece of information when survivability is a concern. For an aircraft carrier it is especially critical given the ship's importance as a national asset. The displacement limit is in place to ensure a number of key criteria are met for the ship. In accordance with Commander, Naval Sea Systems Command (NAVSEASINT 9096.3E, 2005), the following criteria are used to determine the displacement limit for U.S. Navy warships:

- Strength—The displacement, with an assumed longitudinal weight distribution, at which the longitudinal bending moments caused by a

standardized wave will produce the maximum allowable stress in the ship's hull girder.

- Speed—The displacement for surface warships at which the ships machinery, operating at a specified percent of maximum available power, will drive the ship at the original design speed specified by the ships characteristics considering power plant, RPM and torque limits.
- Side Protection System (SPS)—The maximum draft for a surface warship which prevents the top of the SPS from being immersed more than a specified amount
- Subdivisions—The maximum displacement at which a ship with an SPS will satisfactorily resist the flooding effects of a specified number of torpedo hits or similar weapons without submerging the margin line at the bow or the stern.

Ensuring that the displacement limit is not violated will help make sure that, following the unlikely event of a torpedo (or similar weapon) hit, the ship would still be able to provide adequate stability and return to some level of mission capability. Having a side protection system, like the one seen in Figure 17, is vital for a ship to survive the effects of a contact explosion. The basic principle of this system is to provide a barrier that will absorb the brunt of the energy from any explosions while at the same time preventing water from penetrating the ship's vitals.

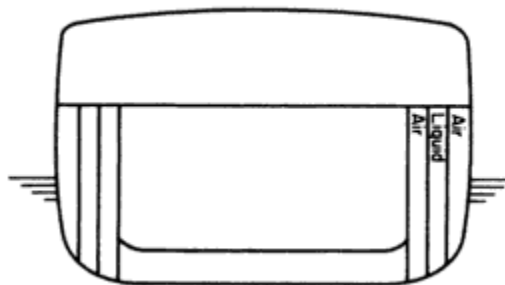

Figure 17. Side Protection System example (From Rawson and Tupper, 1983)

Side Protection Systems have been used in one variety or another since the middle of the nineteenth century. During this time armor cladding was introduced into ship design to protect against weapons that were being designed to penetrate the ship's hull at (or below) the waterline with torpedoes and/or mines. As weapon strength increased so did the thickness of the armor cladding, and therefore the weight of the ship. This began

to cause stability problems, leading to the need for a new protection system. The French Navy introduced the first “torpedo bulkheads” designed to absorb the pressure waves and splinters of torpedo hits (Gillmer and Johnson, 1982). This trend continued and the U.S. Navy started adding these torpedo protection systems to their battleships. Figure 18 below shows a transverse cross section of the USS *West Virginia* (BB 48) with the torpedo protection system highlighted. The USS *West Virginia* (BB 48) had been modified from its original form at commissioning to provide additional compartments to absorb pressure waves.

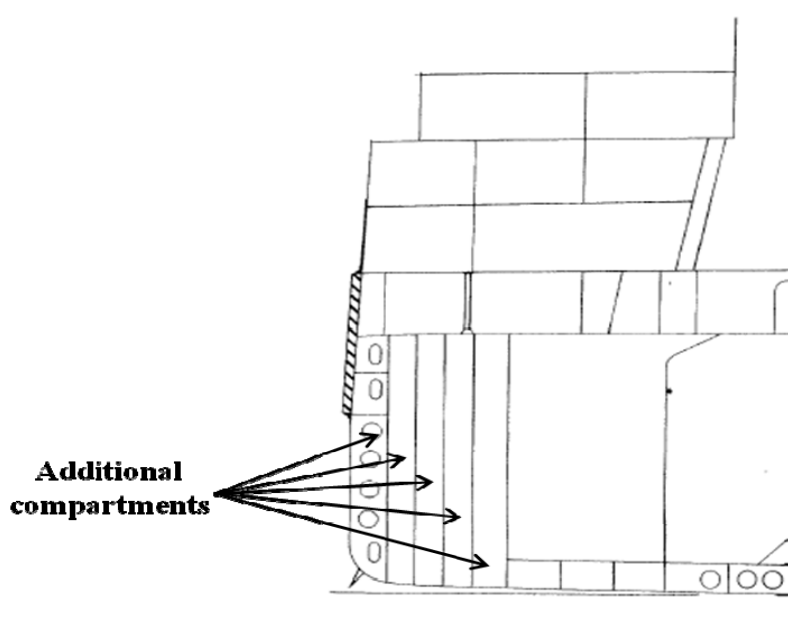

Figure 18. USS *West Virginia* (BB 48) with Torpedo Side Protection (additional compartment) (After Gillmer and Johnson, 1982)

Figure 19 shows a sketch of the torpedo damage that was sustained by aerial torpedo bombers at Pearl Harbor in 1941. The side protection worked as it was designed to, but the seven torpedo hits that *West Virginia* sustained were far beyond the design criteria and the ship sank in shallow water. When she was salvaged, torpedo bulges were added (as shown in Figure 20) for further protection.

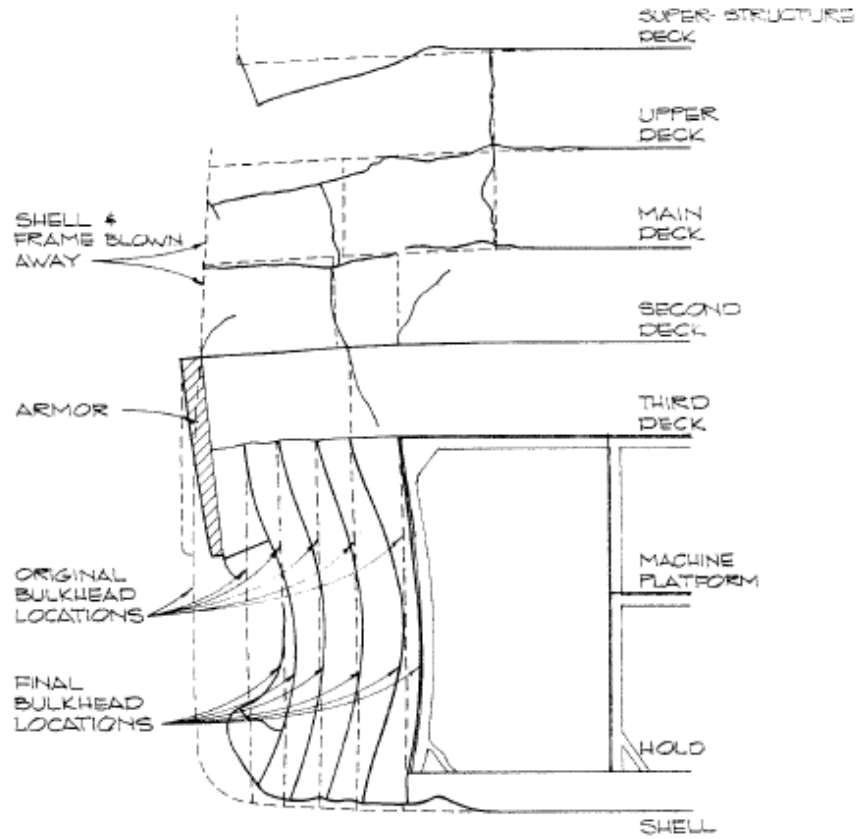

Figure 19. Sketch of torpedo damage to USS *West Virginia* (BB 48) (From Gillmer and Johnson, 1982)

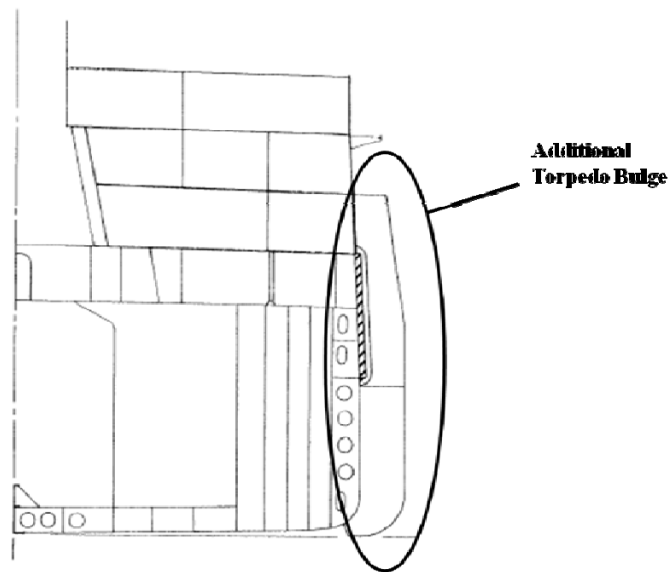

Figure 20. USS *West Virginia* (BB 48) with additional torpedo bulge (From Gillmer and Johnson, 1982)

D. CHAPTER SUMMARY

This chapter provides the background information on the importance of displacement to an aircraft carrier. Archimedes' Law was discussed, as well as how this principle is applied to the displacement of an object in a body of water. The application of these principles also applies to the buoyancy of a ship with special emphasis on how U.S. Navy warships use observed draft marks to determine their own displacement. Displacement is also addressed as a key aspect of a ship's survivability and what has historically been done to help address the threat of torpedoes and mines to warships.

III. HISTORICAL TRENDS IN NIMITZ CLASS CVN

A. INTRODUCTION

Displacement increase over the lifetime of a warship is not a new issue. It is, in fact, expected to occur, and is planned for, during the design and production of a ship through the use of margins, or Service Life Allowances (SLA) for weight and KG. It is the ship's inability to stay within established guidelines and limits that causes problems. As a ship approaches design limits, though, issues such as survivability and maintainability are monitored more closely. It is one of the many goals in ship design to adequately predict and account for long-range projected growth in ship weight.

B. SERVICE LIFE ALLOWANCES (SLA) FOR WEIGHT AND KG

During the acquisition phases of a ship, SLA for weight and KG (sometimes called reserves) are developed to compensate for architectural criteria, such as uncertainties in estimating the ship's weight and center of gravity. By doing this, designers take into account acceptable tolerances in plate profile and pipe thickness, tolerances in metal densities, and changes in the catalogues of suppliers (Biran, 2003). When the ship is delivered, weight calculations still include SLA for weight and KG that take into account such things as:

- trapping of water in places from where it cannot be pumped out
- increase in weight from paint
- increases in weight from equipment additions and ship upgrades

This SLA for weight can vary among ship type, with the approximation of 7.5% of Full Load (FL) Displacement as a standard for aircraft carriers (NAVSEAINIT 9096.6B, 2001).

These acquisition margins and SLA are based on historical data, and from the experience of the estimator. The values also vary with the accuracy and extent of the available information (Comstock, Rossell, and Society of Naval Architects and Marine Engineers (U.S.), 1967). Even with good historical data *and* experienced estimators, these margins and SLA are difficult to calculate, and, more often than not, the SLA fall

short of what the ship's end of service life weight will be. Technological advancements and engineering improvements are two potential issues that impact displacement but are difficult to predict when determining a ship's weight over the course of its lifetime. These are just a few of the problems that plague ship designers and operators.

C. SHIP WEIGHT CONDITIONS

When dealing with an aircraft carrier's weight or displacement, there are a number of components that must be considered. In order to aid in weight and damage control calculations, it is necessary to organize these components into weight groups, or conditions. There are two main conditions that will be investigated here: lightship and full load.

1. Lightship

The ship's lightship condition is the ship's complete weight *without* any variable loads onboard. This weight includes the hull, machinery, outfit, equipment, water in the boilers at steaming level, and liquid in machinery and piping (Gillmer and Johnson, 1982). Some of the variable loads that are omitted from this condition included:

- Personnel and effects
- Ammunition—ship and aircraft
- Provisions
- General stores
- Liquid in tanks
- Aircraft

It is understood that this condition will not likely be encountered during normal service of the ship but may be seen during an availability (a period that the ship is available for maintenance) or when the ship is entering or leaving a dry-dock period. This lightship displacement value (as well as the lightship value for the center of gravity) is typically taken into account as a constant during displacement determinations for future considerations.

As can be seen in Figure 21, the *NIMITZ* class carrier has experienced a general increase in lightship displacement for each subsequent ship built. This should be expected as the class matures and more advanced features are built into each successive ship prior to delivery.

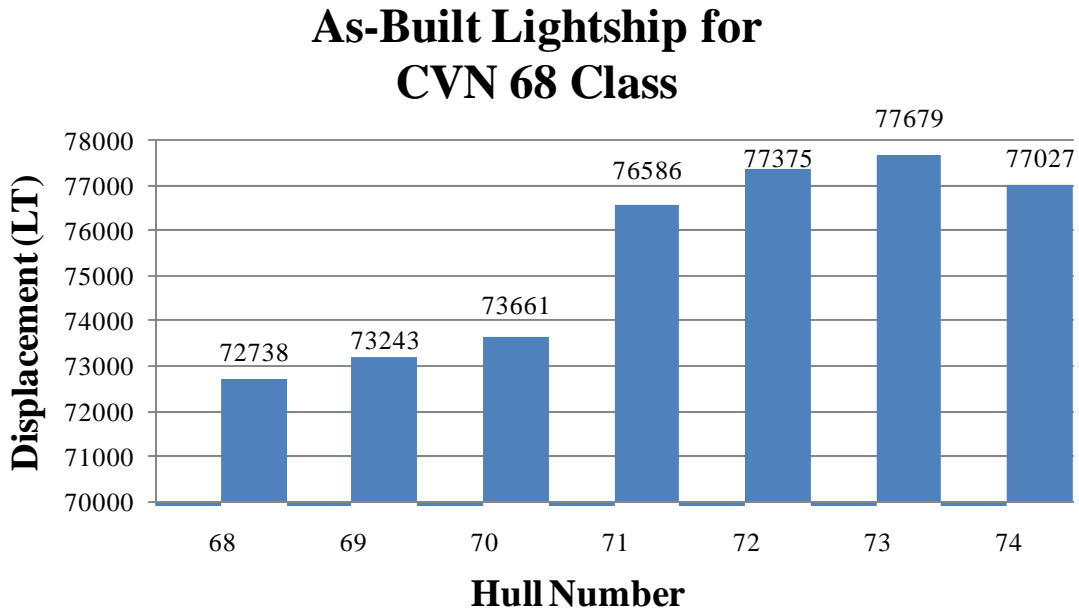

Figure 21. Current Lightship data for CVN 68 class (After Norfolk Naval Shipyard)

2. Full Load (FL) Condition

The carrier’s FL condition is the ship’s lightship weight *and* all variable loads. The sum of all loads in a ship is generally called “deadweight” in the commercial realm and “variable loads” in the navy. For a warship it is called the *FL condition* and can be found by calculating the difference between the ship’s lightship weight and the FL condition weight.

Different types of ships have different deadweight associated with them. Container ships have a deadweight that includes a large cargo element. Tankers have a deadweight that includes a large liquid component. Warships have their own unique elements for FL loads such as a larger crew size, stores, ammunition, and, in the case of an aircraft carrier, an air wing.

Table 2 shows a breakdown of what makes up the FL loads on an aircraft carrier. These loads, combined with the carrier's lightship weight, are what determine the ship's FL displacement. This is what the carrier would be expected to displace during a standard deployment with a full crew complement, complete air wing, close to full fuel tanks (95%), and complete stores load out.

<u>Provisions and Effects</u>	<u>Weight (LT)</u>
Ship Repair Parts	207.51
Aviation Repair Parts	139.25
General Stores	958.60
Medical Stores	15.76
Provisions and Stores	806.60
Ship's Stores Supplies	368.84
Aviation Stores	82.08
AIMD Stores	436.47
Yellow Gear	345.37
Ammunition	1965.04
Officer Effects	121.51
Enlisted Effects	778.58
Female's Berthing	2.47
Miscellaneous Personal Effects	38.61
	<u>6266.69</u>
<u>Tanks</u>	<u>Weight (LT)</u>
Potable Water (100% Full)	1804.14
Reserve Feed Water (100% Full)	944.10
JP-5 (95% Full)	10430.42
Bilge and Oily Water Storage	76.07
Onboard Discharge Storage	137.66
Sewage and Laundry Ejection Tanks (25% Full)	139.36
Lube Oil Storage (95% Full)	112.59
O ₂ N ₂	16.22
AFFF Reserve	30.72
Gasoline	0.60
List Control Tanks	517.17
	<u>14209.05</u>

<u>Aircraft Loads</u>	<u>Weight (LT)</u>
Aircraft	963.88
Aircraft JP-5	616.72
	<u>1580.60</u>

<u>Total Loads</u>	<u>Weight (LT)</u>
Provisions & Effects	6266.69
Tanks	14209.05
Aircraft Loads	1580.60
	<u>22056.34</u>

Table 2. FL load-out elements for NIMITZ class carrier (After Corretjer, 2009a)

With a calculated FL load of 22,056 LT, a reasonable value for the carrier's total displacement can be determined. This is done by adding the value for the FL loads to the ship's lightship displacement. Table 3 and Figure 22 below show these results.

<u>Hull Number</u>	<u>Lightship Displacement (LT)</u>	<u>FL Loads (LT)</u>	<u>FL Condition (LT)</u>
68	72,738	22,056	94,794
69	73,243	22,056	95,299
70	73,661	22,056	95,717
71	76,586	22,056	98,642
72	77,375	22,056	99,431
73	77,679	22,056	99,735
74	77,027	22,056	99,083

Table 3. Carrier FL displacement

LIGHTSHIP AND FULL LOAD FOR CVN 68 CLASS

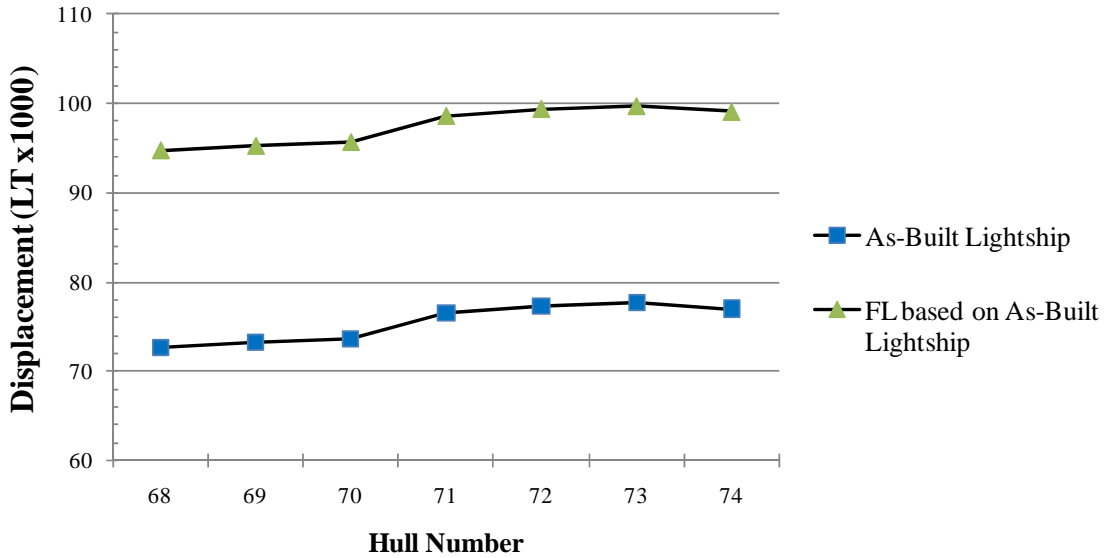

Figure 22. Full Load based on Lightship (After Norfolk Naval Shipyard)

D. TRENDS, SHIPALTS, AND GROWTH MODEL ADJUSTMENTS FOR ALL CARRIERS

The lightship weight is adjusted over the course of a ship’s life. As alterations on the ship occur and new equipment is installed, the lightship value needs to be modified. An example of this can be seen from the data in Table 4 for the growth observed in CVN 68 from delivery to her mid-life Refueling Complex Overhaul (RCOH).

	Lightship Weight (LT)
Delivery	72,736
Post RCOH	77,264
Growth	4,528

Table 4. USS NIMITZ (CVN 68) Lifetime Weight Growth (After: Corretjer, 2009b)

In 1995, a Displacement Test and Loads Survey was conducted on USS THEODORE ROOSEVELT (CVN 71). During the test it was discovered that a large increase in both lightship weight and variable loads weight had occurred. Table 5 below shows these results.

	<u>Delivery (LT)</u>	<u>Test Results (LT)</u>	<u>Growth (LT)</u>
Lightship	76,586	80,632	4,046
Combat Loads	+ 20,799	+ 22,829	+ 2,030
Combat Load Condition	97,385	103,461	6,076

Table 5. USS THEODORE ROOSEVELT (CVN 71) Weight Growth (After Corretjer, 2009b)

As a result of the Displacement Test and Loads Survey, all NIMITZ class carriers had a weight adjustment of approximately 6,000 LT added to their FL load condition to account for “unknown” lightship weight growth and variable loads growth. The addition had a dramatic effect on the class and their proximity to their displacement limit. The impact of this adjustment alone pushed CVNs 69, 72, and 73 above their limit of 103,800 LT, and CVN 71 right up to the limit.

Figures 23–31 display the displacement trends for CVNs 68 through 74. The initial displacement data point for each carrier is calculated by summing the delivery lightship weight and the ship’s FL loads at the time. Each subsequent data point coincides with a maintenance availability. The values of these subsequent data points are determined by taking the previous displacement value and combining that with what was added to the ship during the availability. The projected growth patterns are based on an average of the historic growth patterns. Each graph also shows what the carrier’s end of life displacement is predicted to be based on current trends.

USS NIMITZ (CVN 68) PREDICTED WEIGHT GROWTH

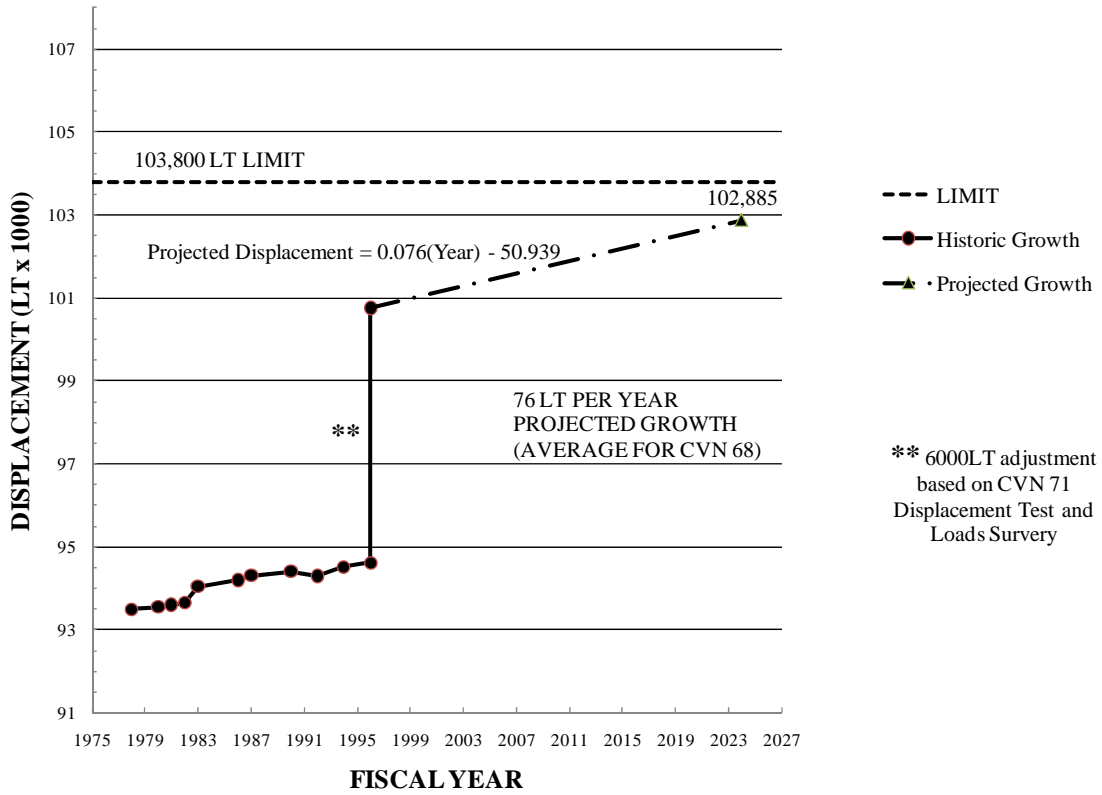

Figure 23. CVN 68 Predicted Weight Growth (After Norfolk Naval Shipyard)

USS DWIGHT D. EISENHOWER (CVN 69) PREDICTED WEIGHT GROWTH

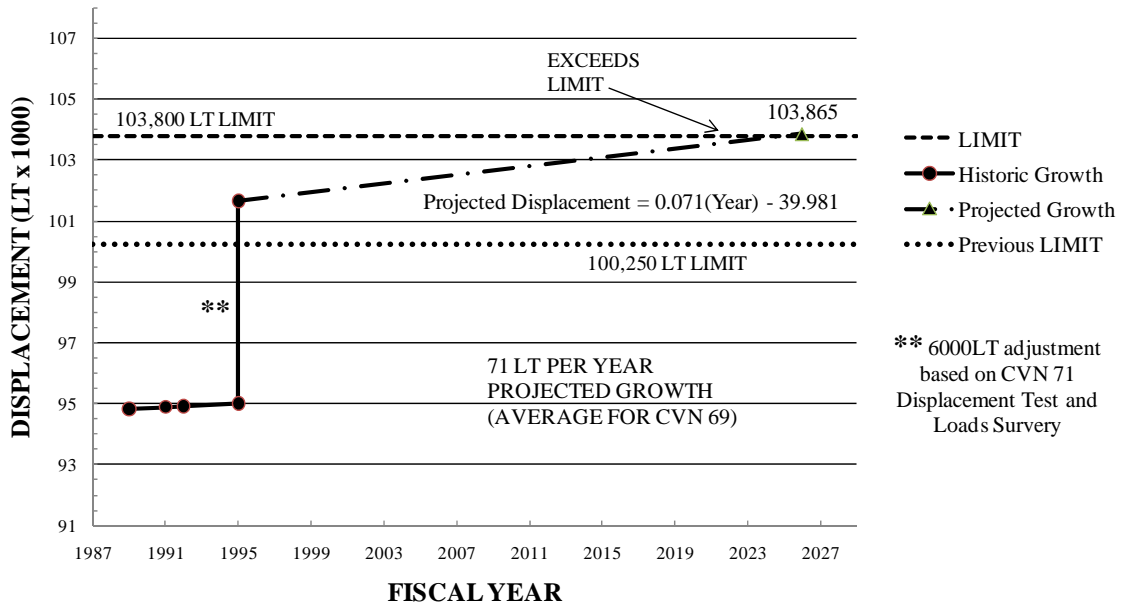

Figure 24. CVN 69 Predicted Weight Growth (After Norfolk Naval Shipyard)

CVN 69 had the lowest displacement limit at 100,250 LT (vice 103,800 LT for all active NIMITZ class carriers). The reason for this is due to the locations on the hull of a number of overboard discharge valve outlets. Due to the outlet locations and their proximity to the waterline, there was a chance of seawater incursion and therefore possible corrosion to piping and engineering equipment. In 1992, a SHIPALT was initiated to correct for this condition that applied to hull numbers 68, 69, 70, and 71. Follow-on carriers (72 through 77) accomplished the alteration during their new construction phase and CVNs 68, 70, and 71 had the modification done during follow-on availabilities. The SHIPALT for CVN 69 was completed during her RCOH in 2001 and her new displacement limit was increased to 103,800 to be consistent with the rest of the class.

USS CARL VINSON (CVN 70) PREDICTED WEIGHT GROWTH

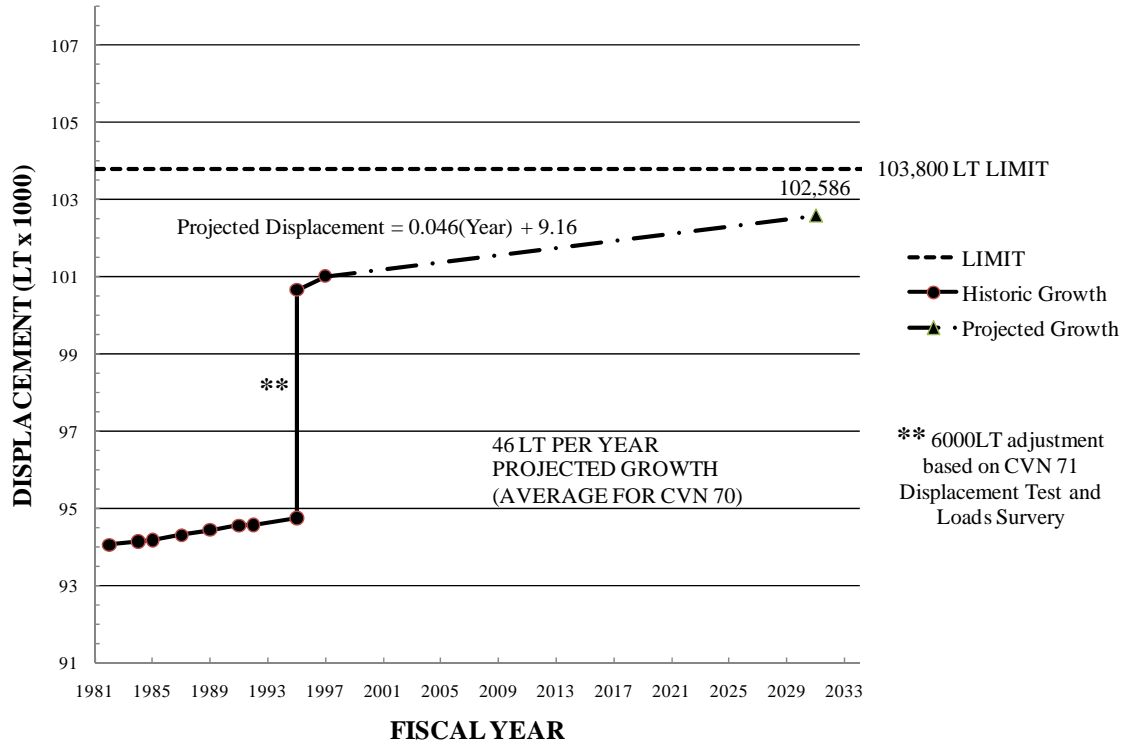

Figure 25. CVN 70 Predicted Weight Growth (After Norfolk Naval Shipyard)

USS THEODORE ROOSEVELT (CVN 71) PREDICTED WEIGHT GROWTH

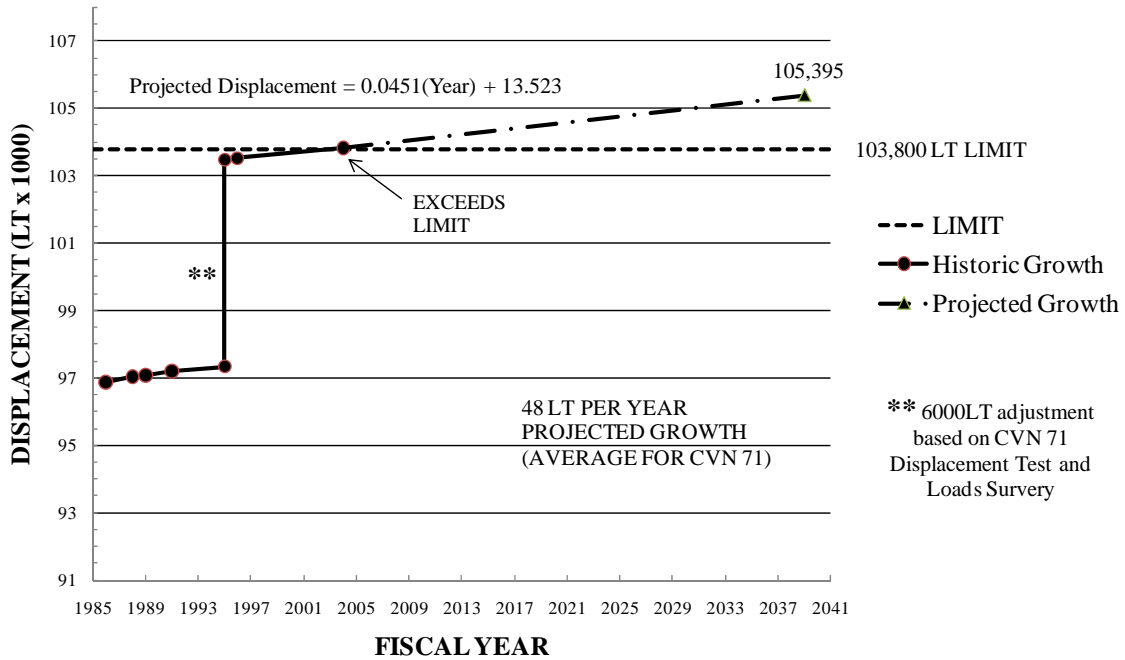

Figure 26. CVN 71 Predicted Weight Growth (After Norfolk Naval Shipyard)

USS ABRAHAM LINCOLN (CVN 72) PREDICTED WEIGHT GROWTH

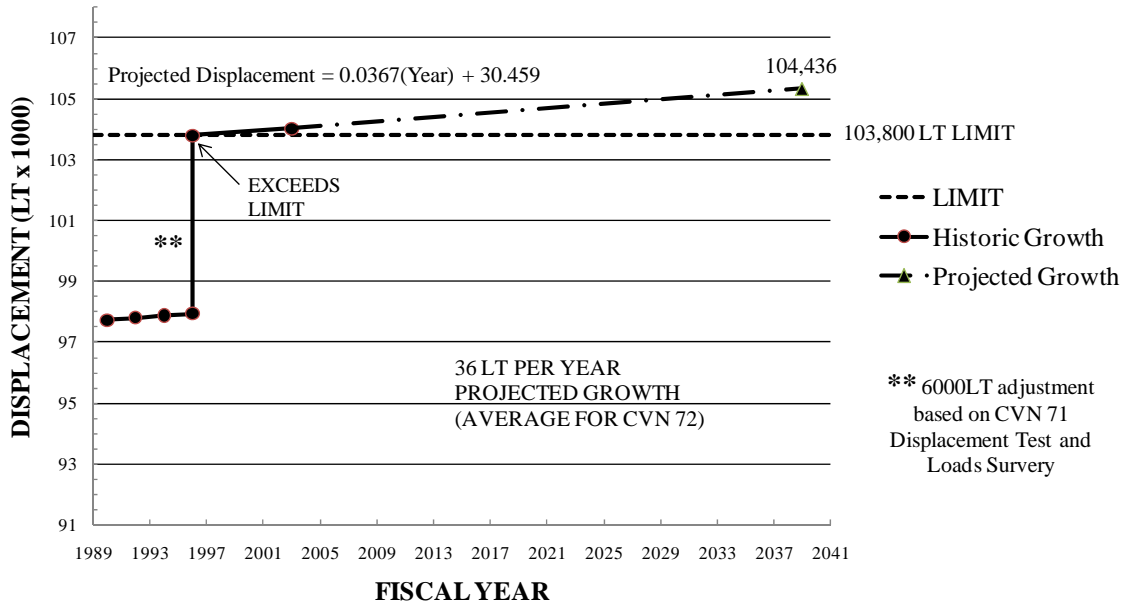

Figure 27. CVN 72 Predicted Weight Growth (After Norfolk Naval Shipyard)

USS GEORGE WASHINGTON (CVN 73) PREDICTED WEIGHT GROWTH

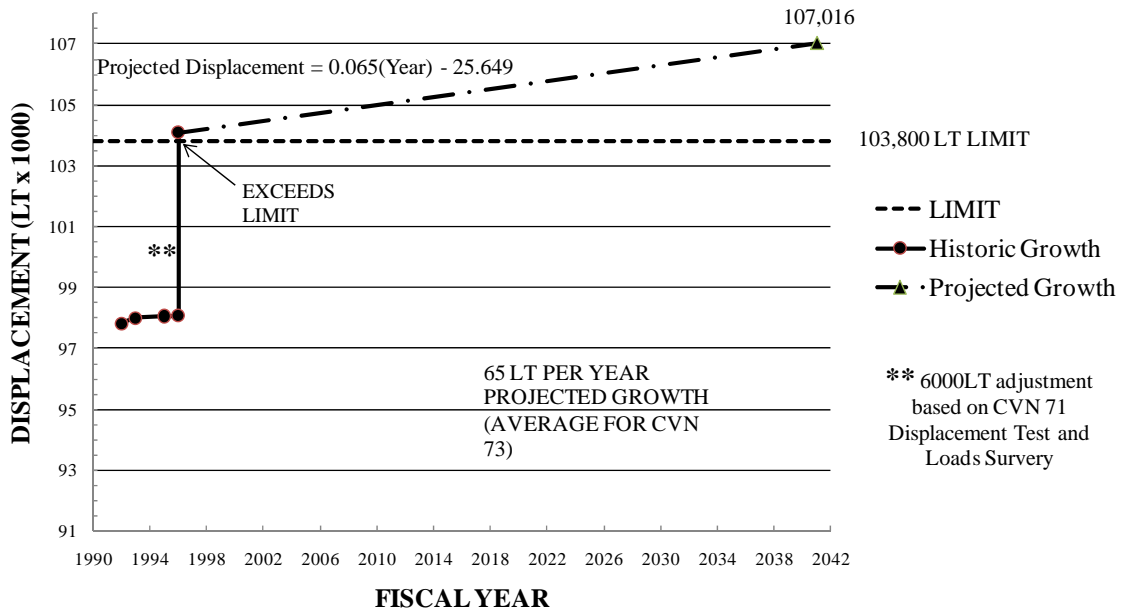

Figure 28. CVN 73 Predicted Weight Growth (After Norfolk Naval Shipyard)

USS JOHN C. STENNIS (CVN 74) PREDICTED WEIGHT GROWTH

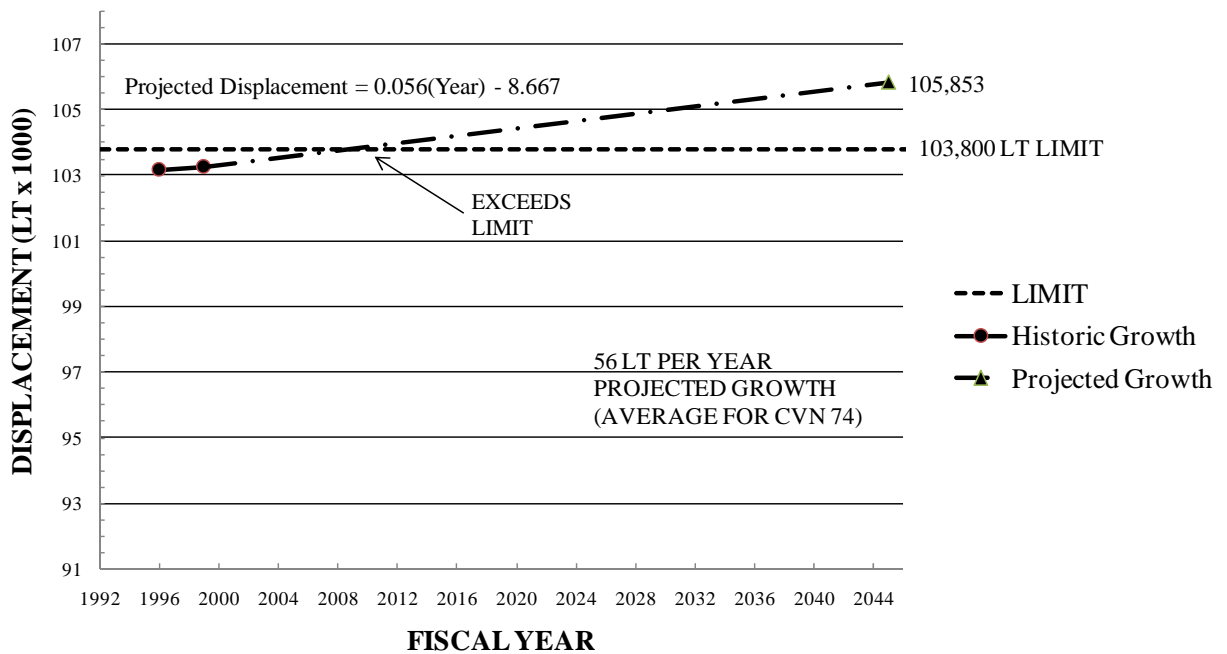

Figure 29. CVN 74 Predicted Weight Growth (After Norfolk Naval Shipyard)

USS HARRY S. TRUMAN (CVN 75) PREDICTED WEIGHT GROWTH

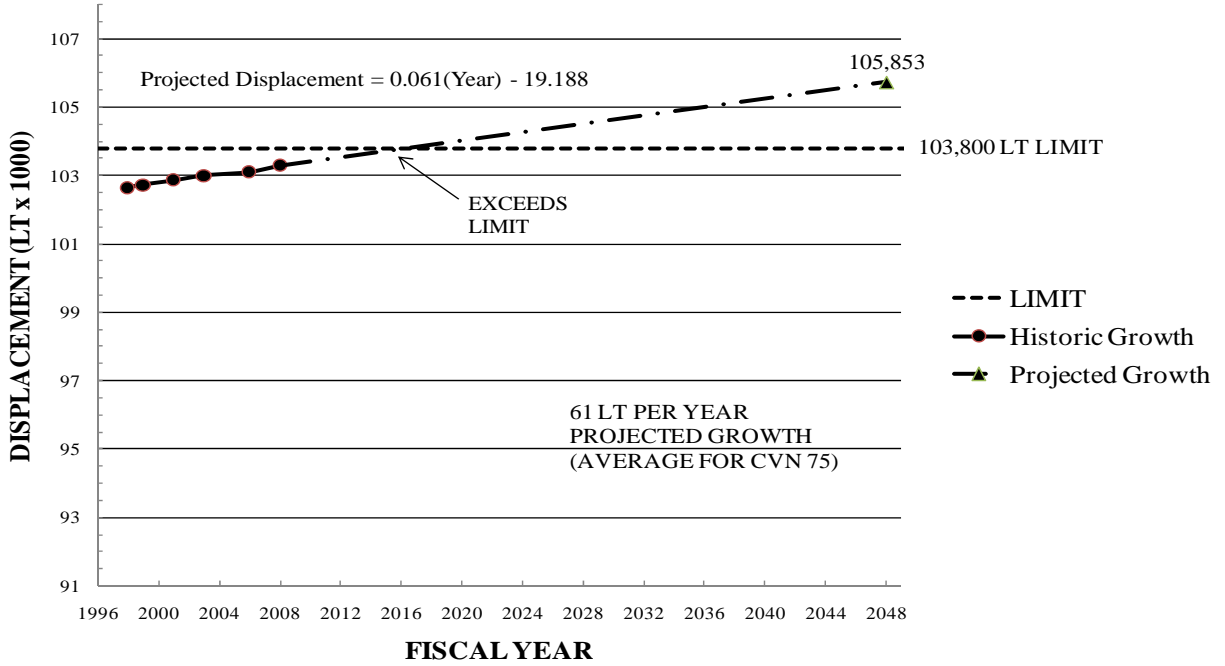

Figure 30. CVN 75 Predicted Weight Growth

USS RONALD REAGAN (CVN 76) PREDICTED WEIGHT GROWTH

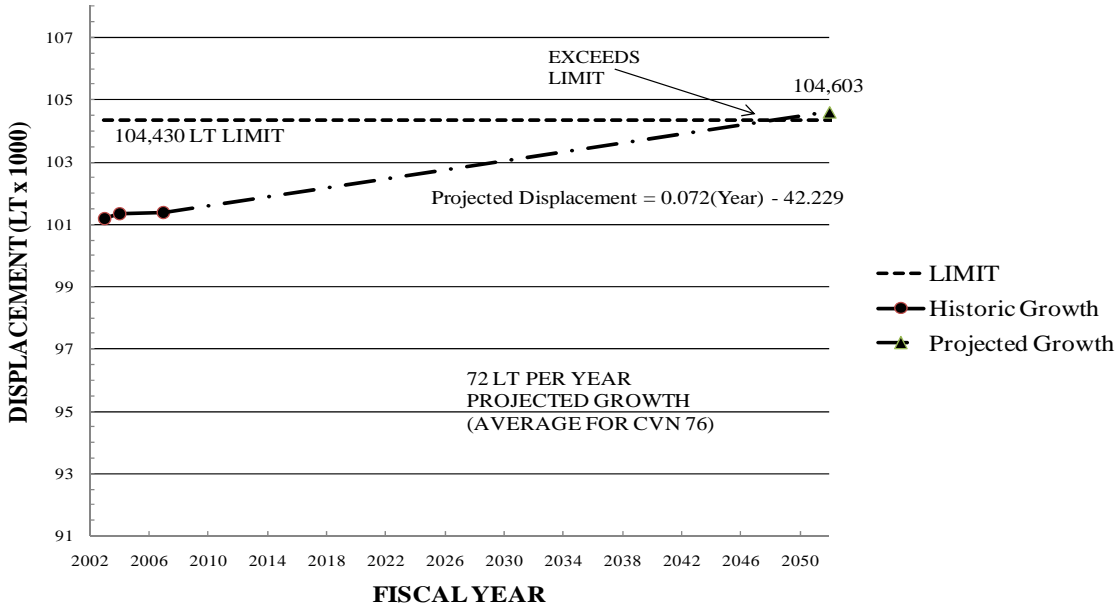

Figure 31. CVN 76 Predicted Weight Growth

As each of these figures has shown, there is clear indication of displacement concerns in the CVN 68 class (see Table 6 for summary). With the exception of CVNs 68 and 70, all of the carriers have violated, or are expected to violate, their displacement limit by the end of their scheduled life. Adjustments can be made to a ship's maintenance plans for those that are nearing the end of their service life to help adjust for increases in ship's weight. Removal of obsolete equipment is an option, but for ships like CVNs 72 through 76, where their weight is predicted to be violated in the first one-half of their life, these adjustments can be difficult, if not impossible to make.

CVN	Limit Exceeded (year)	Projected Limit Exceeded (year)	Projected Growth per Year (LT)	Projected End-of-Life Displacement (LT)
68	-	-	76	102,885
69	-	2025	71	103,865
70	-	-	46	102,586
71	2004	-	48	105,395
72	1996	-	36	104,436
73	1995	-	65	107,016
74	2008	-	56	105,853
75	-	2016	61	105,740
76	-	2048	72	104,603

Table 6. Displacement limit and end of life summary

E. WEIGHT REMOVAL AND ADJUSTMENTS

Certain measures have been taken to help curb or reduce the weight growth seen over the lifetime of the ship. This is especially important with the prospect of exceeding the displacement limit for the majority of the ships. These measures range from more disciplined preservation techniques to removal of weight (see list below for specific items identified for possible removal), and all have the same end goal: keep the displacement under the limit.

1. Paint

The preservation procedures for painting is one method used to ensure weight is not added to the ship. Portions of the ship, to include the hull, superstructure, and spaces

throughout, are painted on a regular basis. The standard procedure for this is to grind away the old paint, prime the area, and repaint. If this standard procedure is not done and areas just painted over, weight can add up from the build-up of material. This can be seen with the example below:

For the sake of simplicity, assume that the carrier's underwater portion of the hull can be described by the illustration in Figure 32. The surface area can be determined by adding together the surface area of the two sides, and the front and back (the top is omitted).

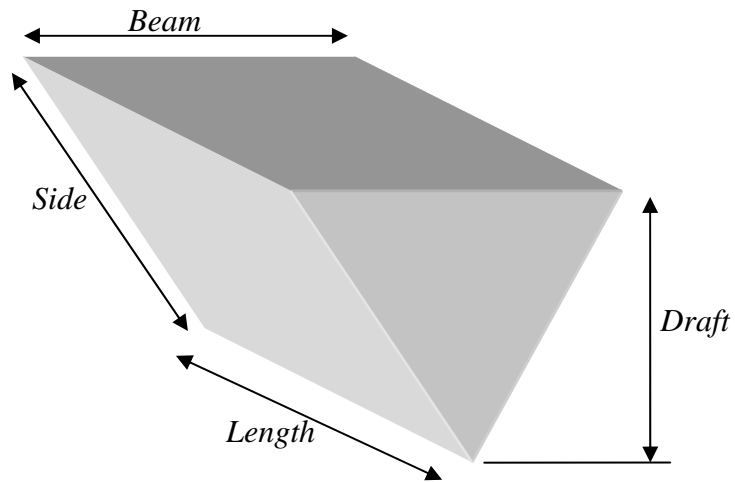

Figure 32. Example hull shape

Assume

$$Length = 1092 \text{ ft}$$

$$Beam = 134 \text{ ft}$$

$$Draft = 40 \text{ ft}$$

$$Side = \sqrt{Draft^2 + \frac{1}{4}Beam^2} = \sqrt{(40 \text{ ft})^2 + \frac{1}{4}(134 \text{ ft})^2} \cong 78 \text{ ft} \quad (1.3)$$

Therefore

$$\begin{aligned} \text{Surface Area} \\ = 2(\text{Length} \times \text{Side}) + 2\left(\frac{1}{2} \times \text{Beam} \times \text{Draft}\right) \end{aligned} \quad (1.4)$$

$$\text{Surface Area} = 2(1092 \text{ ft} \times 78 \text{ ft}) + 2\left(\frac{1}{2} \times 134 \text{ ft} \times 40 \text{ ft}\right)$$

$$\text{Surface Area} = 175,712 \text{ ft}^2$$

Assume that 1 gallon of paint weighs 10 pounds and that the paint has a volatile organic compound (VOC) limit of 3.4 lbs/gal (MIL-PRF-24647D(SH), 2005). VOCs in the paint are the chemical compounds that evaporate before the paint dries. This means that when 1 gallon of paint is used, it will weigh 6.6 pounds when it dries (3.4 lbs of the paint are VOCs). Also assume that 1 gallon of paint will cover an 200 ft^2 area. Therefore, the weight of paint required to cover the ship below the waterline would be equal to

$$175,712 \text{ ft}^2 \times \frac{1 \text{ gallon}}{200 \text{ ft}^2} \times \frac{6.6 \text{ pounds}}{1 \text{ gallon}} \times \frac{1 \text{ ton}}{2000 \text{ pounds}} = 2.9 \text{ tons}$$

This means that roughly 3 tons of paint is required to cover this area of the ship. Taking into account that preservation requires two coats of primer and two coats of paint, the preservation on this portion of the ship would weigh a little over 12 tons in new paint. This may not seem like a lot on a 100,000 ton ship, but add in the paint for the area above the waterline, and all of the spaces within the ship, and it really does make an impact on weight.

It should be reinforced here that the above example was only done to illustrate the *potential* impact that painting and preservation would have on total ship weight, *if correct procedures were not followed*. The hulls of NIMITZ class aircraft carriers are re-painted, using correct procedures, every time the ship is placed in dry-dock. Based on the current NIMITZ class drydocking schedule, this occurs every eight years (B. Cummings, personal communication, May 1, 2009). Painting and preservation above the waterline

can be (and is) done at any time. It is done while the ship is pier-side and underway, and unfortunately correct procedures for preparing the surface are not always followed with the accumulation of paint resulting.

2. Weight Removal

Removal of obsolete equipment is another way to help reduce the overall weight of the ship. In 1985 a ship alteration record for aircraft carriers was created as a means of compensating for changes in ship characteristics, to include weight growth. SHIPALT 3800/1K *Weight and Moment Compensation* was developed as a result of all CVs and CVNs at or approaching Stability Status 2 which prohibited an increase in weight without compensation.

This SHIPALT is a recurring alteration that is intended to be accomplished during each maintenance availability. It is developed such that prior to each availability ship department heads are contacted and asked to identify items or pieces of equipment that would decrease the ship's weight if they were to be removed, replaced, or modified. This information is collected from all departments and compiled in a *Candidate List* which is then submitted in a *Shipcheck Report* report to NAVSEA. This report will include, among other things, the following data:

- Item's description
- Location
- Weight change
- Cost estimate to accomplish removal, modification, or replacement

Based on the information in the report, NAVSEA will authorize a list of items to be removed under SHIPALT 3801K. It should be noted that funding is a major consideration in deciding whether or not a piece of equipment is authorized for removal. There have been certain items identified such as brominators and some air compressors that have been inactivated and have SHIPALTS for removal but have been deferred for a number of years due to not being high on the funding priority list (E. Chambers, personal

communication, March 25, 2009). Other specific items that have been identified (D. Parks, personal communication, April 7, 2009) and are awaiting either approval or funding are:

- Forward accommodation ladders
- Forward boat booms
- Burton/Saddle Replenishment at Sea (RAS) winches
- Aircraft Fueling Stations (AFS)
- JP-5 system for Jet Engine Test Facility
- Electric powered bridge crane
- Aviation suit cooling and drying system
- Helicopter Electrical Startup Stations (HESS)
- Aircraft Intermediate Maintenance Department (AIMD) work center trolley track and turntable

One piece of equipment that has been considered for removal is the Aircraft Elevator (ACE) platform lock. There are four ACEs onboard NIMITZ class carriers and of these four elevators, two of them have four platform locks installed while the other two have ten installed. Results of High Impact Shock testing, as well as changes in other requirements have reduced the number of ACE platform locks required from ten to four per elevator. This reduction will significantly reduce the life cycle operating costs of this system by reducing maintenance and repair costs, as well as improve ACE system readiness by decreasing system downtime. Each ACE platform lock weighs approximately one ton so the overall impact of removing these locks will be a weight reduction of 12.2 tons (E. Chambers, personal communication, April 10, 2009).

Another item that has been identified for modification is the life rafts onboard the ship. Current personnel requirements have the NIMITZ class carriers carrying an average of 254 MK-6, 25 person life rafts. As a result, stowage and deck spacing have become a problem. The rubber sealing bands on the MK-6 life rafts have also been shown to cause Foreign Object Damage (FOD) to aircraft when they come loose. SHIPALT 8775 calls for the installation of new 50 man life rafts that have a number of advantages. These rafts are manufactured with an internal seal that eliminates the FOD

problem. Also, by reducing the number of rafts onboard the cost to certify them drops. Last, with the replacement of the 25 man rafts with the 50 man rafts, a total of approximately 14 tons can be removed from the ship (D. Parks, personal communication, April 14, 2009).

3. New Construction

During design and construction of newer ships in a class, it is inevitable that items are identified that could be designed better, or are not needed, and are not built into the newer carrier. Many of the items identified can also be back-fitted for redesign or removal from the older ships in the class, and by doing so will help remove weight from the ship. During the design and build of USS GEORGE H. W. BUSH (CVN 77) a number of items and systems were identified for redesign or removal from earlier carriers:

Redesign

- 400 Hz Solid State Frequency Converter
- Fixed Deck Edge Integrated Catapult Control Station Cab
- Weapon Elevator Control
- Hangar Divisional/Deck Edge Door Lock Actuators
- Aircraft Elevator Stanchion

Removal

- Emergency Air Breathing system
- Draft Indicating System
- Catapult Waterbrake Coolers

There were also a number of additional items that were identified for changes on CVN 77 that will have an impact of approximately 957 LT removed from the ship over the course of its lifetime (C. Corretjer, personal communication, April 7, 2009).

F. CHAPTER SUMMARY

This chapter provides the historic trends into the CVN 68 class displacement. Design margins for ship weight, as well as commissioning margins, are addressed, to include the difficulty in accurately estimating these values over the lifetime of the carrier.

Ship weight conditions are discussed; specifically the concepts of Lightship as well as Full Load weight. Those items making up the variable loads were examined as well as adjustments to these loads following load surveys. The trends of weight conditions over the course of the carrier's lifetime, as well as the differences between different ships within the class, were seen. Lastly, the efforts that have been made in order to help reduce and manage ship weight, were addressed.

IV. CURRENT TRENDS IN NIMITZ CLASS CVN

A. INTRODUCTION

Determining a ship's displacement is not an unusual task. It is, in fact, a daily procedure for a ship, while both inport and underway. With knowledge of the ship's displacement, at a given time, coupled with knowledge of changes in load, the navigator is more prepared for coming into port because the draft associated with the changed displacement is known. Tracking a ship's displacement is also critical in implementing successful damage control efforts in combating flooding. With the significance that this value has on the ship's safety and survivability, it is easy to understand the concern that having too high of a displacement has caused.

B. UNDERWAY DISPLACEMENT AND DRAFT DETERMINATION

While the methods for calculating a ship's actual displacement can vary, the basic underpinnings are the same: start with a known displacement (based on determinations from visual draft readings and curves of form) and adjust this value as variable loads onboard the ship change. There are many things that go into the variable loads, but the main contributors to these changes on an aircraft carrier are:

- fuel consumption (JP-5)
- changes in the onboard airwing
- changes in the onboard munitions
- changes in liquid loads (other than fuel)

Operationally, the results of displacement determinations are included on a draft report that is completed daily. This daily report is then provided to a number of different departments onboard the ship to include Engineering, Navigation, and Reactor. There are two types of reports that can be created; the first is a visual report and the second is a calculated report.

Figure 33 shows an example of the first report, which is based on a visual determination of the fore and aft drafts. The displacement is determined from these

readings and the use of the curves of form. This type of report is typically created while pier-side but can also be done by lowering a small boat into the water and viewing the draft marks at that point in time.

** DRAFT REPORT **					
(IMPORT)					
TYPE: VISUAL		EVOLUTION: DAILY			
CURRENT	01-Jul-08			LIST:	1/4 PORT
	FEET	INCHES		TRIM:	1/4 STERN
DRAFT FWD	38	9			
DRAFT AFT	38	6			
NAV DRAFT	46	7 1/2			
MEAN DRAFT	38	7 1/2	DISPLACEMENT:	96,987 LT	
PREVIOUS	30-Jun-08			LIST:	1/8 STBD
	FEET	INCHES		TRIM:	1/4 STERN
DRAFT FWD	38	9			
DRAFT AFT	38	6			
NAV DRAFT	46	7 1/2			
MEAN DRAFT	38	7 1/2	DISPLACEMENT:	96,987 LT	
CALCULATION					
PREVIOUS FUEL:	2958315	GALLONS	8974.5	TONS	
CURRENT FUEL:	2958315	GALLONS	8974.5	TONS	
DIFFERENCE:	0	GALLONS	0.0	TONS	
PREVIOUS WATER:	478100	GALLONS	1770.5	TONS	
CURRENT WATER:	491200	GALLONS	1828.7	TONS	
DIFFERENCE:	15100	GALLONS	56.2	TONS	
COMBINED DIFFERENCE:	15100	GALLONS	56.2	TONS	
209 TONS REQUIRED TO CHANGE DRAFT ONE INCH (AVG TPI)					
JP-5 = 6.8 LBS/GAL WATER = 8.33 LBS/GAL					
NAV DRAFT = MEAN DRAFT + 8 FT					
REMARKS / AMPLIFYING INFORMATION:					
Draft was estimated by means of daily fuel & water report, based on the last visual draft taken.					
New mean draft calculated by means of straight line on draft diagram & functions form with known displacement.					
STATUS OF LIST CONTROL WATER:		478,108	LBS	213.4 TONS	
SUBMITTED: _____ REVIEWED: _____ APPROVED: _____					
____DC(original) ____CHENG(copy) ____DCA(copy) ____RX(copy) ____BRIDGE(copy) ____DCC(x2copies)					

Figure 33. Daily inport draft report example (From CVN 69, 2008)

Figure 34 shows an example of the second draft report, a calculated reported, which is based on the change in weight of the variable loads onboard the ship (typically over a 24-hour period) since the previous report. There are many inputs to this report including aircraft, fuel onboard, ammunition, and liquid loads.

DAILY DRAFT REPORT						
Date	Yesterday		Today			
2-Feb-08 Calculated	Unit Weight	Number Onboard	Weight	Number Onboard	Weight	
Super Hornets (F/A-18E or F)	58,000	24	1,392,000	24	1,392,000	
Prowlers (EA-6B)	52,000	4	208,000	4	208,000	
CODs (C-2)	45,000	0	0	2	90,000	
Hawkeyes (E-2C)	44,500	4	178,000	4	178,000	
Hornets (F/A-18C)	37,500	20	750,000	20	750,000	
Seahawks (H-60)	22,000	7	154,000	7	154,000	
		59	2,682,000	61	2,772,000	
Total Aircraft Weight (LT)			1,197		1,238	
Change in Aircraft Weight (LT)					40	
Fuel Onboard (gal)			2,931,952		2,828,162	
Fuel %			81.4%		78.5%	
Fuel Weight (LT)			8,901		8,585	
Change in Fuel (gal)					-103,790	
Change in Fuel (LT)					-315	
Ammo (tons)			2,042		2,042	
Change in Ammo (LT)					0	
Potable Water (gal)			393,000		428,500	
Potable Water %			80.9%		88.2%	
Reserve Feed (gal)			156,800		149,600	
Reserve Feed %			85.7%		81.8%	
CHT Tanks						
	FWD	8-49-4-W	14.5%	3,000	9.2%	1,900
		8-49-3-W	16.4%	3,400	9.7%	2,000
		8-54-6-W	9.5%	2,100	8.1%	1,800
	MID	8-128-2-W	4.9%	1,200	20.4%	5,000
	AFT	6-200-0-W	4.2%	2,200	9.6%	5,000
Change in Water Load (LT)					420	
Total Change in Displacement (LT)					-155	
Tons Per Inch Immersion					253.9	
Total Sinkage (in)					-1	
				Feet	Inches	
Total Sinkage				0	-1	
Draft		Feet	Inches	Feet	Inches	
Forward		36	9	36	8	
Aft		37	9	37	8	
Mean		37	3	37	2	
Displacement (LT)			92,749		92,594	
Trim (°):			1/16	By the Stern	List (°):	P/S

Submitted by: _____ EOOW/EDO: _____
DCWS: _____ DCA: _____
Fire Marshal: _____ Chief Engineer: _____

Figure 34. Daily underway draft report example (From CVN 68, 2008)

Some ships also take into account the change in stores onboard the ship as well, while others do not track this change because this weight is usually too small to make a difference. Data in the report is collected from various departments (Air for aircraft and fuel, Weapons for ammunition, and Supply for stores), and liquid levels are determined from either sounding the tanks or remote tank level indicators.

It is important to understand that the calculated determinations are rough estimates (since the loads on the ship are constantly changing), but that the methods currently used *are* adequate at obtaining the needed information. It isn't until the ship is able to get a visual determination that the true values are best determined.

C. DRAFT REPORTS

As previously mentioned, draft reports are typically compiled daily. These reports might be done more than one time during a 24-hour period as well. If the ship were to take on fuel (or provide fuel to another ship in the squadron) another reports might be completed. The same might happen if the ship goes to anchor and a visual reading was to become available.

With the use of electronic records management (i.e., Excel), some ships maintain a number of year's worth of draft reports. These records are also maintained in life cycle engineering and management files to support ship acquisition, modernization, and material support. Ships are required to maintain draft reports for a minimum of two years and send their records to Program and Life Cycle Managers annually where they are destroyed after ten years ((Carey, 2007), p III-9-6).

D. PRESENT CVN DISPLACEMENTS

This section reports on the draft data obtained from the carriers in the fleet. The Pacific Fleet's Force Naval Engineer sent a message to all of the CVN 68 class aircraft carriers requesting their draft/displacement data for as far back as they had records. This request was sent to all of the carrier's Chief Engineers. All ships were asked to provide their daily displacement readings in an effort to try to establish a trend on the actual readings and to find out what the ship's displacement is during actual operating conditions. These data points were plotted in Excel and peak values were determined.

With the exception of the USS CARL VINSON (CVN 70), all carriers were able to provide usable data. CVN 70 has been in RCOH since November 2005, and the data that she provided didn't show the ship's displacement outside of the shipyard. While in RCOH she was in a modified lightship condition with most variable loads removed

before entering dry-dock. Any variation in her day-to-day displacement was due to changes in loads such as the addition or removal of cranes and other shipyard related maintenance equipment.

Each daily reading was plotted over time for each carrier. These plots are shown below in Figures 35–43. Below each weight plot a schedule is also provided. This was done in an effort to more easily interpret the changes seen in the weight data. Peak readings all correspond to when a ship was deployed or during miscellaneous underway operating conditions. It is during these times that the ship would presumably be at her heaviest with a full air wing, munitions (during a combat deployment), JP-5 tanks filled and in use, and all crew and effects onboard. This would be seen as her *actual operating condition*. Lower displacement values typically correspond to when a ship was in a maintenance availability and variable loads not onboard.

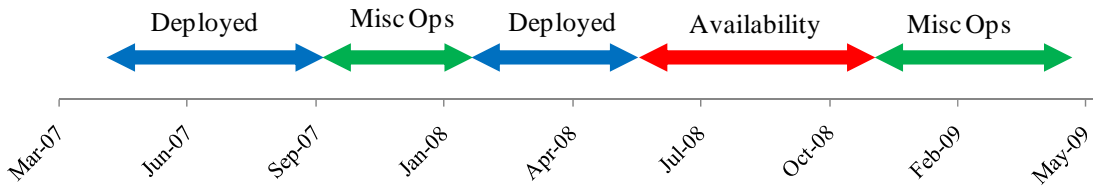
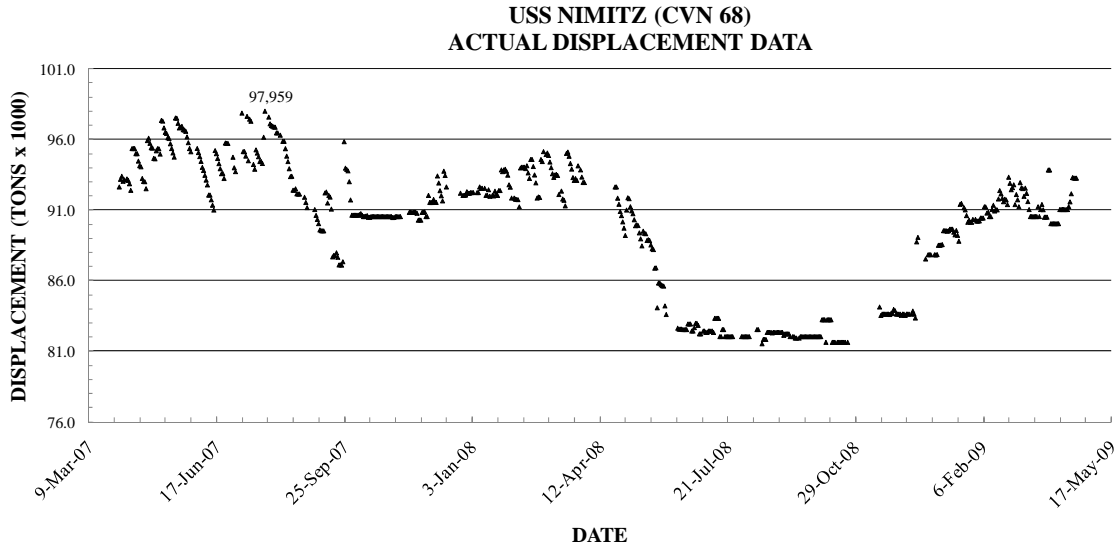

USS NIMITZ (CVN 68) Schedule

Reporting Period	Peak Displacement During Period (LT)	Activity During Peak Displacement	Number of Displacement Readings
2 Apr 07 - 20 Apr 09	97,959	Deployed	616

Figure 35. CVN 68 Actual Displacement Readings

**USS DWIGHT D. EISENHOWER (CVN 69)
ACTUAL DISPLACEMENT DATA**

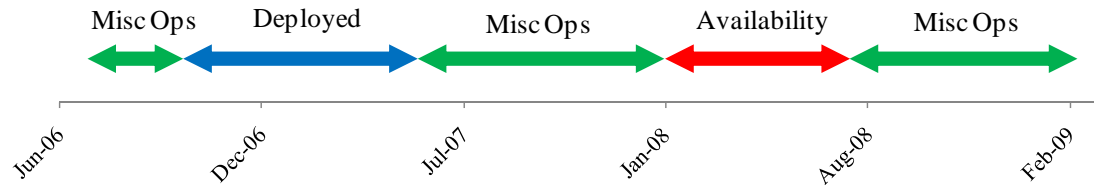
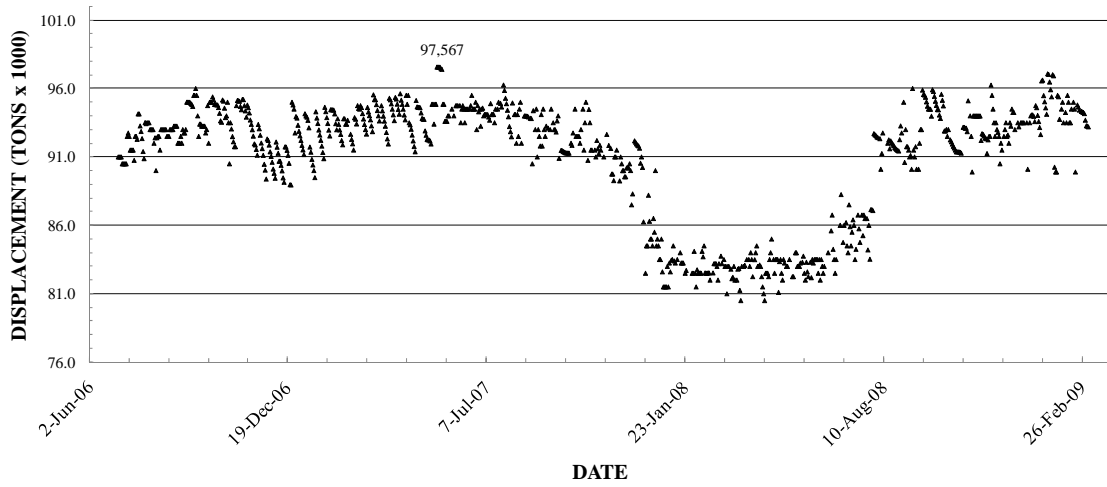

USS DWIGHT D. EISENHOWER (CVN 69) Schedule

Reporting Period	Peak Displacement During Period (LT)	Activity During Peak Displacement	Number of Displacement Readings
1 Jul 06 - 4 Mar 09	97,567	Deployed	879

Figure 36. CVN 69 Actual Displacement Readings

**USS CARL VINSON (CVN 70)
ACTUAL DISPLACEMENT DATA**

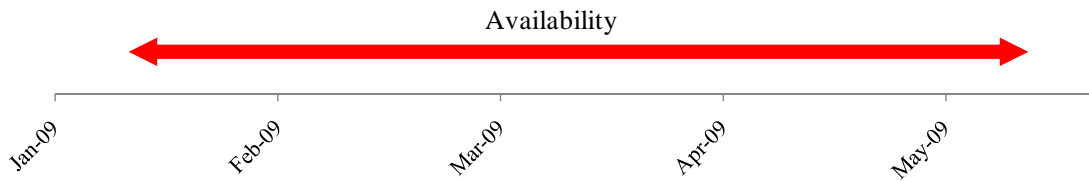
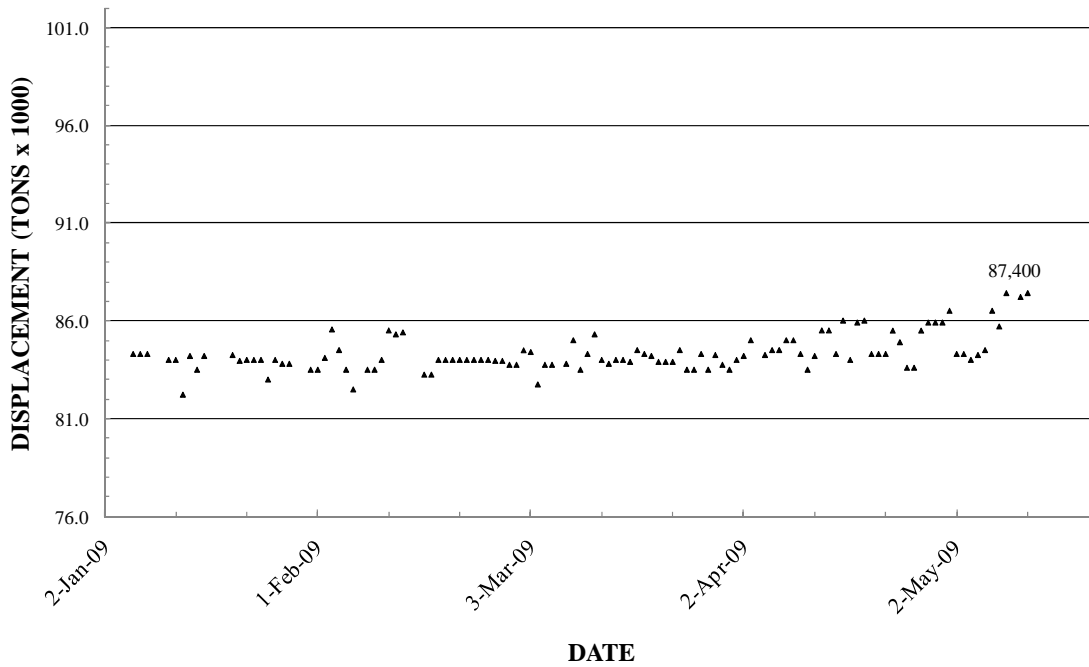

USS CARL VINSON (CVN 70) Schedule

<u>Reporting Period</u>	<u>Peak Displacement During Period (LT)</u>	<u>Activity During Peak Displacement</u>	<u>Number of Displacement Readings</u>
6 Jan 09 - 27 Mar 09	87,400	Availability	70

Figure 37. CVN 70 Actual Displacement Readings

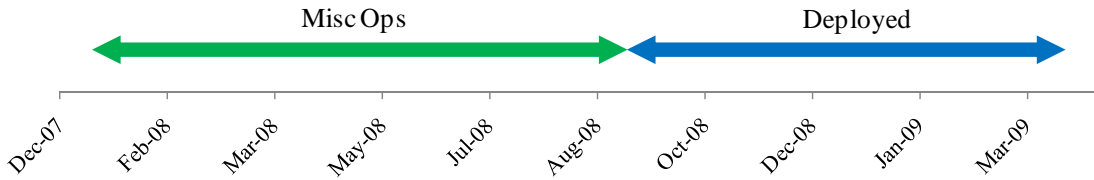
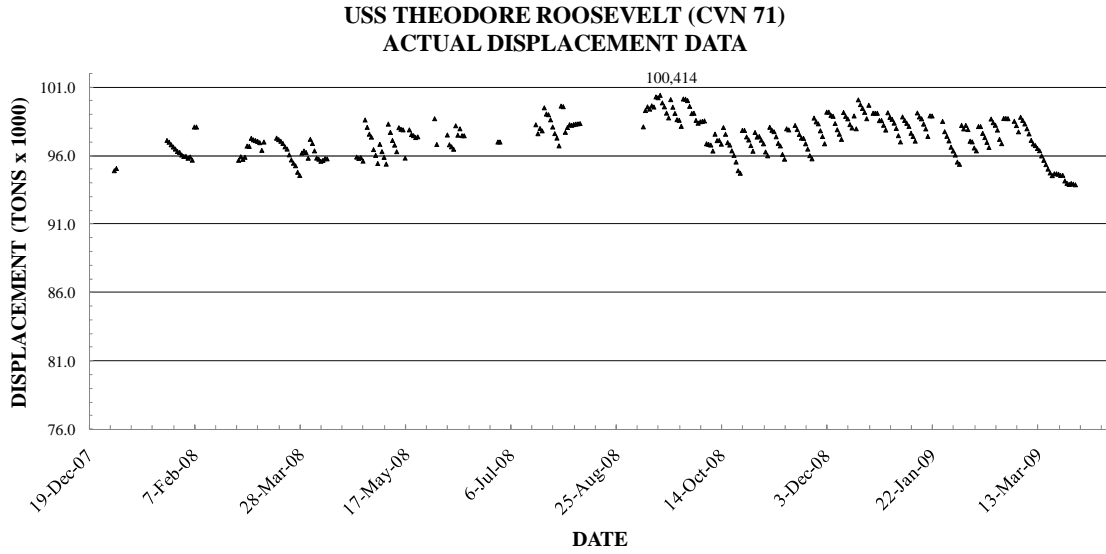

USS THEODORE ROOSEVELT (CVN 71) Schedule

Reporting Period	Peak Displacement During Period (LT)	Activity During Peak Displacement	Number of Displacement Readings
31 Dec 07 - 31 Mar 09	100,414	Deployed	316

Figure 38. CVN 71 Actual Displacement Readings

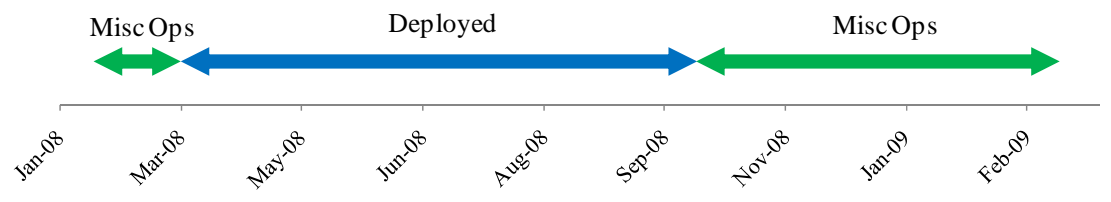
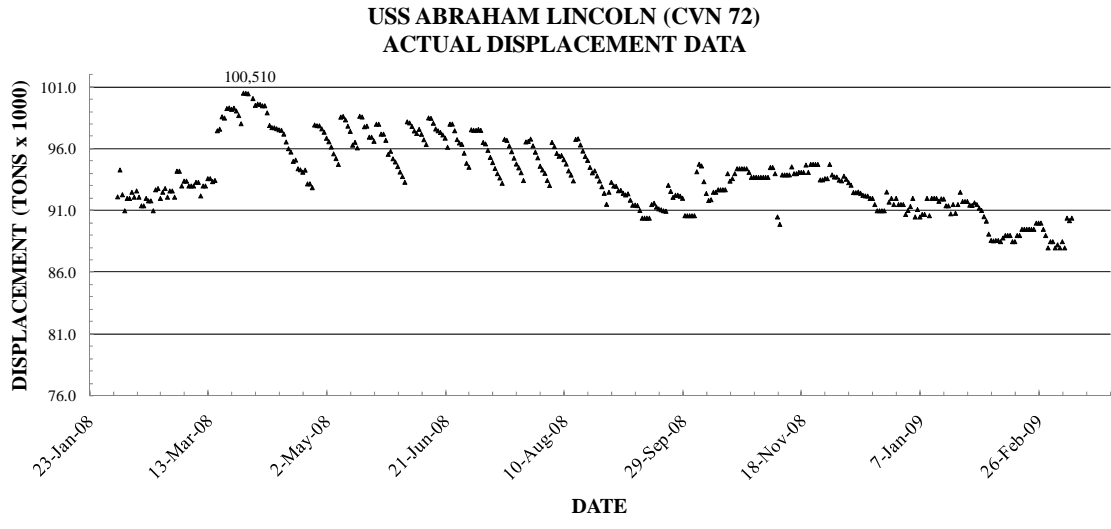

USS ABRAHAM LINCOLN (CVN 72) Schedule

Reporting Period	Peak Displacement During Period (LT)	Activity During Peak Displacement	Number of Displacement Readings
4 Feb 08 - 12 Mar 09	100,510	Deployed	402

Figure 39. CVN 72 Actual Displacement Readings

**USS GEORGE WASHINGTON(CVN 73)
ACTUAL DISPLACEMENT DATA**

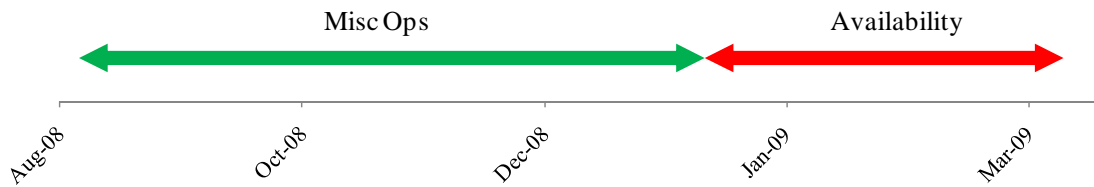
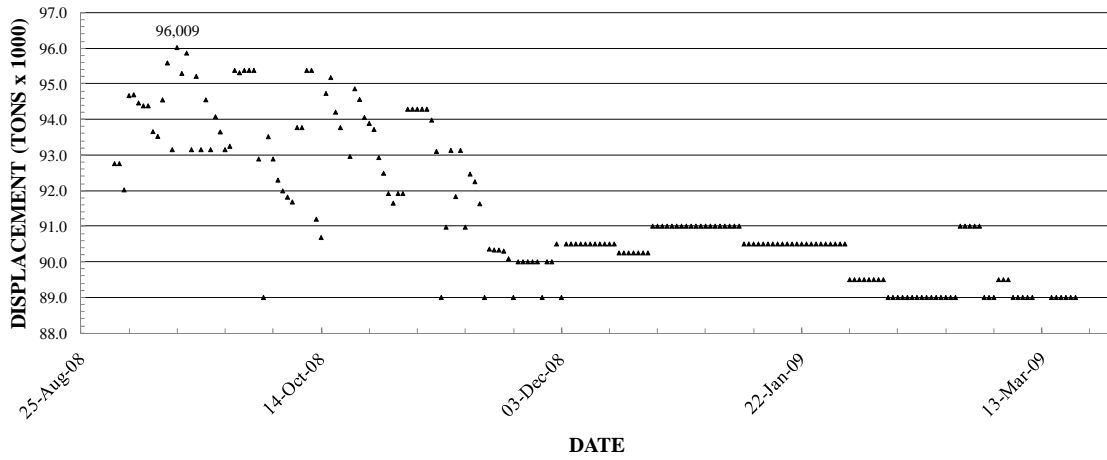

USS GEORGE WASHINGTON (CVN 73) Schedule

Reporting Period	Peak Displacement During Period (LT)	Activity During Peak Displacement	Number of Displacement Readings
1 Sep 08 - 20 Mar 09	96,009	Misc Ops	197

Figure 40. CVN 73 Actual Displacement Readings

**USS JOHN C. STENNIS (CVN 74)
ACTUAL DISPLACEMENT DATA**

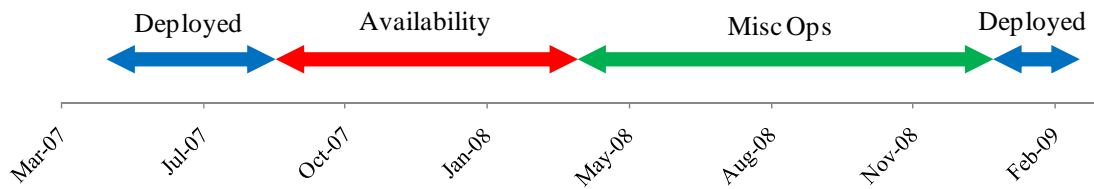
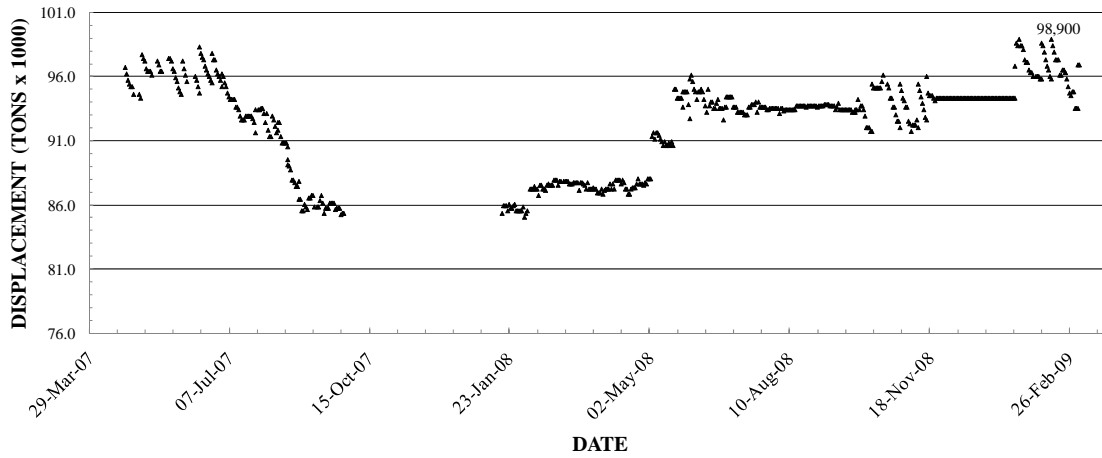

USS JOHN C. STENNIS (CVN 74) Schedule

Reporting Period	Peak Displacement During Period (LT)	Activity During Peak Displacement	Number of Displacement Readings
24 Apr 07 - 5 Mar 09	98,900	Deployed	570

Figure 41. CVN 74 Actual Displacement Readings

**USS HARRY S. TRUMAN (CVN 75)
ACTUAL DISPLACEMENT DATA**

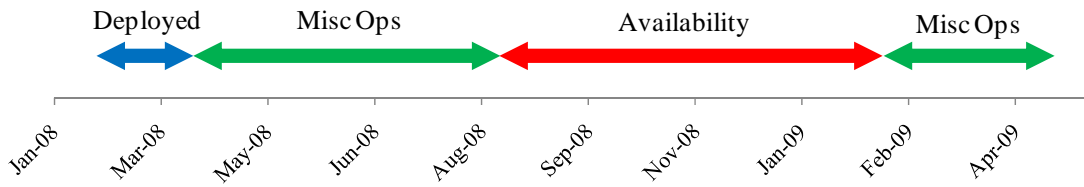
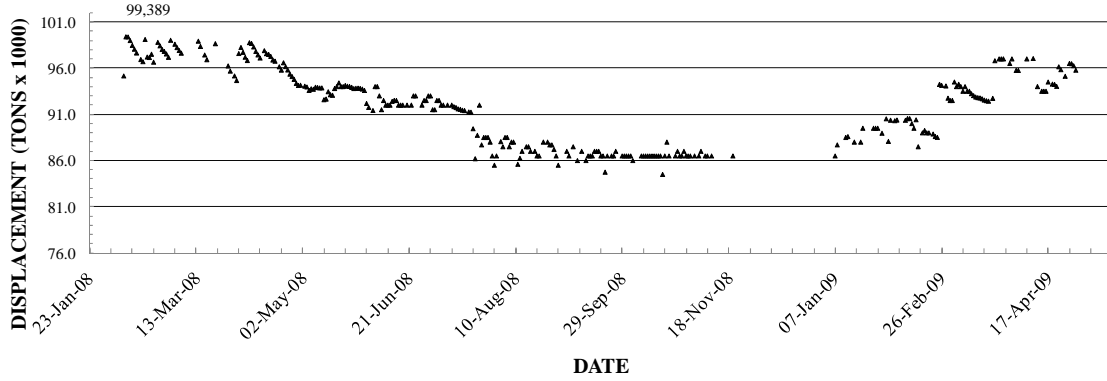

USS HARRY S. TRUMAN (CVN 75) Schedule

Reporting Period	Peak Displacement During Period (LT)	Activity During Peak Displacement	Number of Displacement Readings
8 Feb 08 - 30 Apr 09	99,389	Deployed	301

Figure 42. CVN 75 Actual Displacement Readings

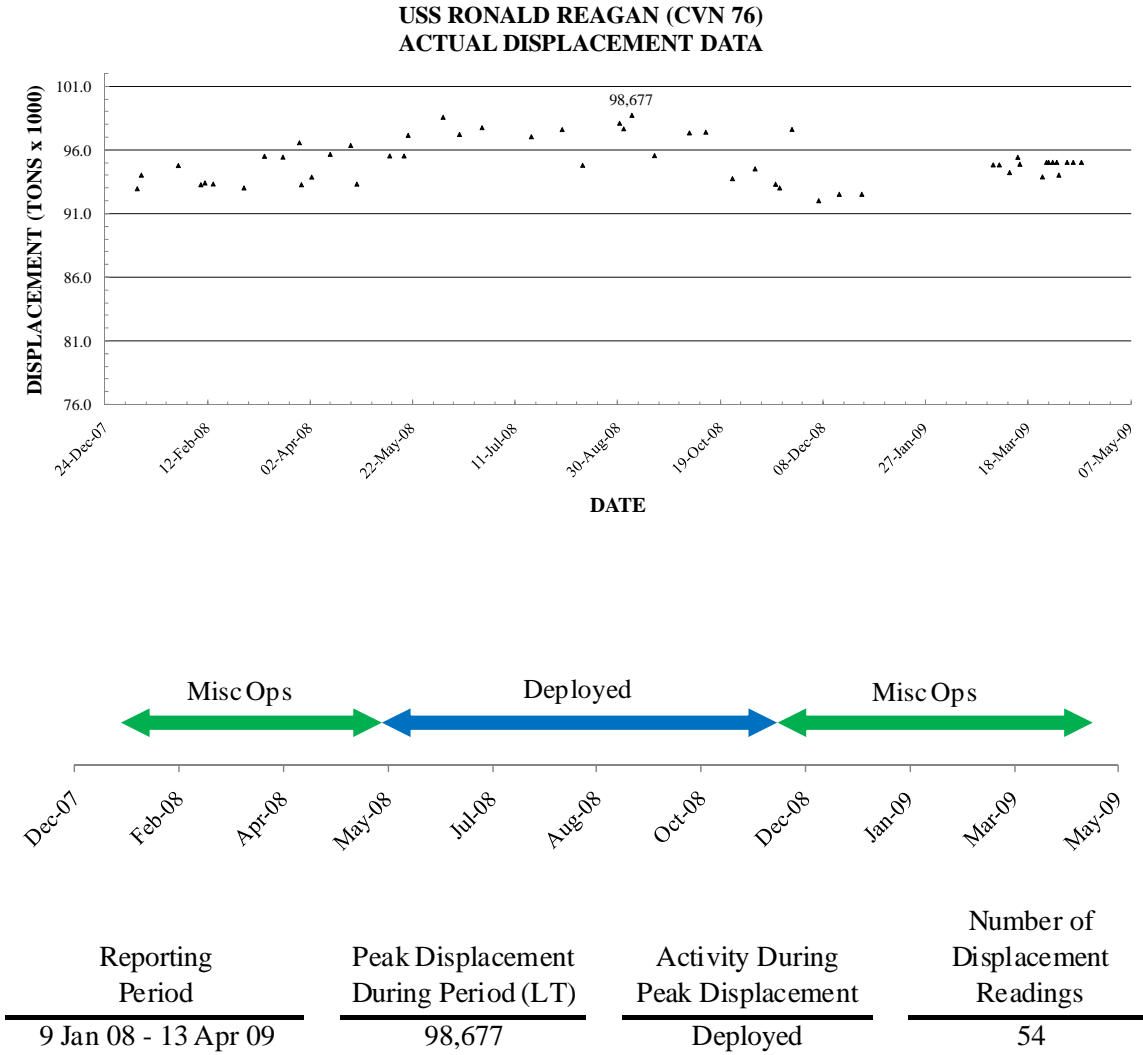

Figure 43. CVN 76 Actual Displacement Readings

E. RESULTS

As expected, the displacement for each carrier varies from day to day. This is for a number of reasons, such as changes in the number of aircraft onboard, the number of bombs or other munitions, the variations in JP-5 tank levels, or changes in potable water levels. A cyclic pattern is visible while the ship is at sea (either on deployment or conducting miscellaneous operations). There are daily decreases in displacement until a RAS is performed that brings on JP-5 (or provisions) and the cycle begins again.

Chapter III included models that mapped out what the carrier’s displacement has been in the past, and well as what it is projected to be in the future. Each model also showed a formula that was used to determine what the displacement will be at any time in the future based on growth pattern seen on that ship in the past. With these formulas, a predicted value for each carrier’s displacement at the time corresponding to the peak displacement has been found. These values are displayed in Table 7. Along with these values, is shown the difference between the predicted value and the actual peak value as reported by the carrier.

<u>CVN</u>	<u>Peak Displacement During Reporting Period (LT)</u>	<u>Predicted Displacement Based on Model (LT)</u>	<u>Difference between Peak and Predicted (LT)</u>
68	97,959	101,631	-3,672
69	97,567	102,542	-4,975
70	87,400	101,574	-14,174
71	100,414	104,116	-3,702
72	100,510	104,161	-3,651
73	96,009	104,917	-8,908
74	98,900	103,840	-4,940
75	99,389	103,307	-3,918
76	98,677	102,383	-3,706

Table 7. Reported Displacement vs. Predicted Displacement for all carriers

Even with CVN 70 being an anomaly due to the fact that she was in an RCOH during the reporting period, every carrier is reporting a displacement an average of approximately 4,500LT less than the model is predicting for this time in their life. This difference between the predicted displacement and the actual operating displacement will be addressed further in Chapter V.

F. CHAPTER SUMMARY

This chapter provided the current displacement trends in the CVN 68 class, as reported by the operational aircraft carriers. The methods which aircraft carriers use to determine their displacement, while both pier-side and underway, are addressed. Draft reports are discussed along with the disposition of those reports over time. Lastly, the actual displacement readings for each carrier were reported. With these individual

reports are summaries which include the ship's operational schedule during the reporting period, as well as the differences that are seen between what the ships are reporting as their displacement and where they are predicted to be based on NAVSEA's trend models.

V. ANALYSIS OF RESULTS, RECOMMENDATIONS, AND CONCLUSION

A. INTRODUCTION

Establishing the fact that there is a difference between what the carriers are modeled to displace, and what they are actually displacing, is the first step in solving the displacement issues. Determining where these differences occur is the next step. There are many things that can be done to adjust the ship's displacement values. Another Displacement Test and Loads Survey like the one conducted on the USS THEODORE ROOSEVELT (CVN 71) is one option. Addressing the changes in the loads that make up the variable loads is another.

It is, however, important that something be done. With the carriers in Stability Status II, where "neither an increase in weight nor a rise of a ship's center of gravity can be accepted", ship maintainers' hands are tied. SHIPALT 3801K outlines that an increase in weight cannot be accepted without concurrent compensation. This is usually easier said than done, since there usually isn't spare equipment lying around on an aircraft carrier that can just be removed. It is also very expensive to remove weight from the ship. Accordingly, ship maintainers have not been providing the required weight and/or moment compensation via SHIPALT 3801K.

B. ANALYSIS OF RESULTS

By collecting displacement readings from active CVN 68 class aircraft carriers, a determination can be made regarding differences between actual and model predicted displacements. The models are only concerned with what the carrier's actual operating conditions are. Furthermore, the models are only looking at what the carrier is displacing at its heaviest point at a specific time. It is at these points that it can be assumed that the carrier has a full air wing, full JP-5 tanks, full outfit of armament, and all crew and effects onboard. In other words, all variable loads are at their maximum weight. With this being

said, it is then important to note that the only data points collected from the fleet that have any real bearing are those points that correlate to when a carrier is at its heaviest. These points would typically correspond to when a ship is deployed.

All collected displacement values were analyzed for the differences between the actual displacement and the model-predicted displacements. The top 24 values (where the peaks were closest to the model) were taken from this report, which is summarized in Table 8. Displacement values from CVNs 70 and 73 were omitted from the analysis. Neither of these two carriers were deployed during their reporting periods (70 was in RCOH and 73 was conducting miscellaneous operations) so the data they provided didn't reveal true actual operating conditions (i.e., they were not at their heaviest).

<u>CVN</u>	<u>Displacement (LT)</u>	<u>Date</u>	<u>Predicted Displacement Based on Model (LT)</u>	<u>Difference between Peak and Predicted (LT)</u>
72	100,510	28-Mar-08	104,161	-3,651
72	100,494	29-Mar-08	104,161	-3,667
68	97,959	25-Jul-07	101,636	-3,677
72	100,463	30-Mar-08	104,162	-3,699
71	100,414	15-Sep-08	104,116	-3,702
76	98,677	06-Sep-08	102,396	-3,719
68	97,826	7-Jul-07	101,632	-3,806
71	100,298	13-Sep-08	104,115	-3,817
76	98,517	06-Jun-08	102,378	-3,861
71	100,242	14-Sep-08	104,115	-3,873
75	99,389	09-Feb-08	103,307	-3,918
75	99,376	10-Feb-08	103,307	-3,931
71	100,148	26-Sep-08	104,117	-3,969
71	100,136	27-Sep-08	104,117	-3,981
76	98,385	3-Jul-08	102,383	-3,998
68	97,596	11-Jul-07	101,633	-4,037
72	100,076	01-Apr-08	104,162	-4,086
68	97,543	28-Jul-07	101,636	-4,093
68	97,482	16-May-07	101,621	-4,139
75	99,100	18-Feb-08	103,308	-4,208
75	99,009	01-Mar-08	103,310	-4,301
75	98,978	11-Feb-08	103,307	-4,329
76	98,054	31-Aug-08	102,395	-4,341
72	99,626	03-Apr-08	104,162	-4,536

Table 8. Summary of 24 heaviest points collected CVN 68 class carriers

As can be seen, the closest any active carrier came to the model's predicted displacement is CVN 72 when she was 3,651LT *lighter* than the model. Table 9 provides a statistical summary of the data collected in Table 8.

Mean	-3,972.45
Median	-3,950
Standard Deviation	244.89
Minimum	-4,536
Maximum	-3,651
Count	24

Table 9. Statistical Summary of Differences Between Peak and Predicted Displacements

The NAVSEA model used to project aircraft carrier displacement is flawed, with the closest that it has come to accurately predicting a displacement being 3,651 LT. As a result of this, ship maintainers are being forced adhere to difficult and costly requirements for weight removal based on the carrier's stability status (Status 2).

C. WEIGHT MODEL ADJUSTMENTS

Having established that there is a difference between the modeled and actual displacements, an analysis was done to identify what might be causing this variation. In order to do this, the weight distribution on the ship was broken down into separate parts to more easily show what pieces make up the whole ship and to help identify where discrepancies might be.

The Ship Work Breakdown Structure (SWBS) was the starting point in this analysis. The SWBS is a system used to systematically identify the structures, systems, and subsystems that make up a ship. The breakdown of structures for this analysis has been done in line with the *Navy's Expanded Ship Work Breakdown Structure* (Commander, Naval Sea Systems Command, 1985). Components have been broken down into the following ten categories:

Group	Category
100	General Guidance and Administration
200	Hull Structure
300	Propulsion Plant
400	Electric Plant
500	Command and Surveillance
600	Auxiliary Systems
700	Outfit and Furnishings
800	Armament
900	Integration/Engineering
1000	Ship Assembly and Support Services

Ship components, equipment, and machinery are placed into one of the listed categories during design and construction of the ship. For the most part these are considered non-variable loads and therefore not a feasible place to look for discrepancies in weight. Categories are further broken down into subsystems from this point. Two additional categories are used that account for Loads and Margins. The *Loads* category breaks items down into a number of categories, of which a few are listed below:

- Ship's Force, Troop, and Passengers
- Mission Related Expendable and Systems
- Ordinance/Ammunition
- Stores
- Fuels and Lubrication
- Liquids and Gases

As discussed in Chapter III, the variable loads on an aircraft carrier can be broken down into these same types of categories. Figure 44 below shows the breakdown of these loads and how they are distributed in terms of their contribution to the whole full load. This load breakdown is a key component of the displacement model and where the investigation for variation should focus.

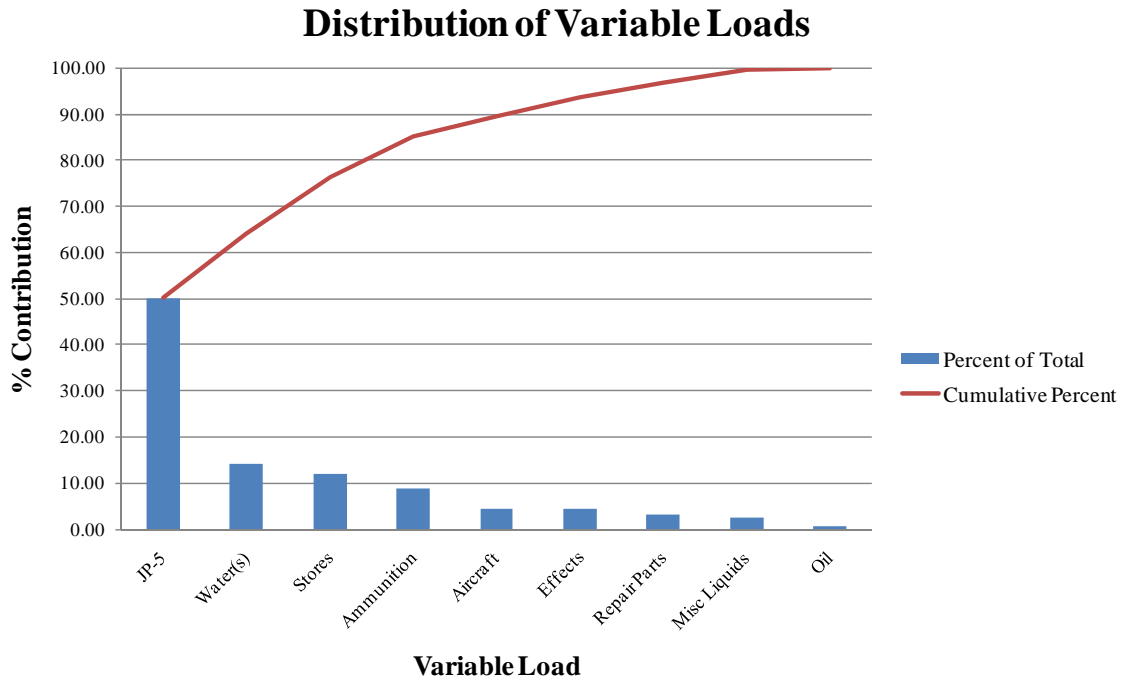

Figure 44. Pareto chart depicting distribution of variable loads

It is among these variable loads that the discrepancies between the modeled and actual displacements most likely lie. Liquid loads on the ship (JP-5, water, miscellaneous liquids, and oil) should remain fairly constant over the course of a carrier’s life since tank size and location are unlikely to change significantly. The same rationale can be used to describe stores, effects, and repair parts. Two areas where variations are most likely to have occurred are ammunition and aircraft.

The contribution that ammunition makes to the variable load on a CVN 68 class aircraft carrier is 1,965.04 LT (~9% of total variable load). This is based on a check of the 2008 load-out onboard the USS THEODORE ROOSEVELT (CVN 71) just before her RCOH. Prior to that, the contribution due to ammunition was considered to be 2,456 LT which was based on the 1995 AOC check on CVN 71. The ammunition onboard a deployed warship is obviously dependent on the mission at hand. It is understandable that this load-out will also vary as different weapons are developed and used. This should be a source of possible variation to periodically verify any changes in weight.

The carrier air wing composition is another source of possible variation. The contribution that the air wing makes to the variable loads is 1,580.6 LT. This weight determination is based on the USS GEORGE WASHINGTON's (CVN 73) air wing in 1999. At the time, CVN 73's air wing was comprised of the following aircraft:

- Hornet (F-18)
- Tomcat (F-14)
- Prowler (EA-6B)
- Hawkeye (E-2C)
- Vikings (S-3A)
- Seahawk (SH-60)

In 2008, USS NIMITZ (CVN 68) deployed with the following air wing composition which had a weight of approximately 1,234 LT:

- Hornet (F/A-18C)
- Super Hornet (F/A-18E/F)
- Hawkeye (E-2C)
- Seahawk (SH-60)
- COD (C-2)
- Prowler (EA-6B)

The difference between these two air wing compositions is 313 LT. This is an obvious source for variation that can easily be corrected and tracked in the future.

Figure 45 below shows a cause and effect diagram that depicts a number of things that could contribute to the changes that are being seen in displacement. Though each item shown only has a small contribution to the potential overall change, the group as a whole can have a significant impact if not addressed.

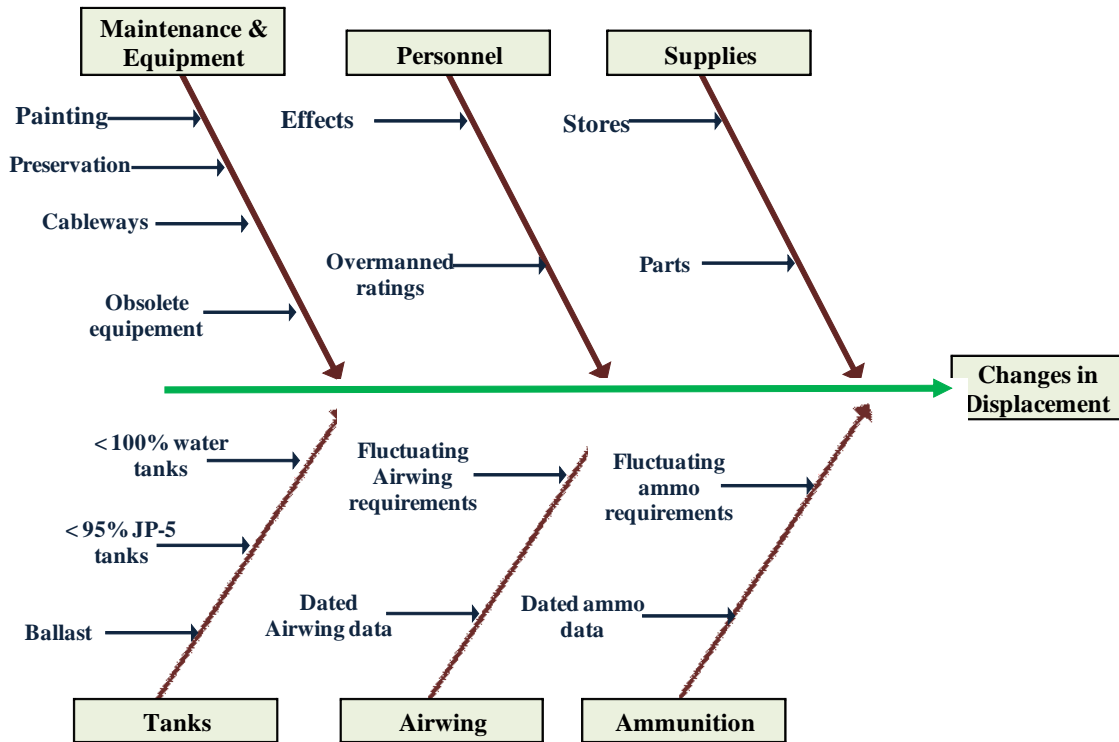

Figure 45. Cause and Effect diagram

D. RECOMMENDATIONS AND CONCLUSION

Some of the adjustments recommended above are only a temporary fix to the issue at hand. Conducting an AOC Displacement Check is the only way to satisfactorily measure the carrier's full load condition. The last AOC Displacement Check was done in 1995 onboard the USS THEODORE ROOSEVELT (CVN 71) (C. Corretjer, personal communication, April 7, 2009), and it is clear that there have been changes in the variable loads since then.

An AOC Displacement Check is a time consuming evolution (12 days), it must be done on a *deployed* aircraft carrier so that the readings reflect the carrier at her heaviest, and it requires the assistance of the whole crew. During the check, ship's force personnel will be required to assist by providing access into all spaces on the ship (storerooms, magazines, communication spaces, staterooms, berthing, fan rooms, etc.). The ship's force personnel will also need to ensure that they have sufficient knowledge of the full load conditions for their assigned spaces.

The check culminates with the readings of the draft marks. In order to get accurate draft readings the following must occur:

- Ship must be stopped
- All bilges must be pumped dry
- Number and approximate location of *all* personnel on board must be known
- Small boats must be lowered into the water to take readings

The draft readings that are observed, together with the ship's curves of form, will then be used to establish the ship's displacement. This is what will be considered the carrier's FL condition displacement, and the basis for where the model predicts the ship's displacement to be.

Considering that the ship is on deployment, this process can be seen as obtrusive and detrimental to the mission at hand. Without conducting this check, though, a more accurate value for the displacement of the ship will not be known.

The cost of between \$400K and \$500K to conduct the check can also be a deterrent. Consider, though, the cost of *not* doing the check. Since the carriers are in Stability Status II and weight compensation must be done, removal of weight is required if anything is added to the ship. It has been estimated that to *remove* something from the ship it would cost approximately \$50K per ton (B. Cummings, personal communications, May 1, 2009). If a one-ton piece of equipment was identified and removed from the CVN 68 class it would cost

$$\frac{1 \text{ ton}}{\text{carrier}} \times \frac{\$50K}{\text{ton}} \times 10 \text{ carriers} \cong \$500K$$

This is about the same cost of doing an AOC. This is only a *one-ton* piece of equipment as well. Most removed equipment will weigh more than that, and therefore cost more.

Consider then that the AOC Displacement Check reveals that the carrier's displacements are actually lower than the models have predicted. This could allow for the relaxing of the restrictions that are placed on ship maintainers by not requiring that weight compensation (for the purpose of displacement) be performed. This will also be a

cost benefit over the lifetime of the carrier by not requiring the removal of equipment to compensate for added weight. By showing that the displacement of these ships is less than actually predicted, the carriers could then all be placed in Stability Status III where “an increase in the ship’s weight is acceptable, but a rise of the ship’s center of gravity must be avoided”. There will still be concerns when weight is added to the ship, but now the concern will be with *where* it is added, not the fact that it *is* added.

E. CHAPTER SUMMARY

This chapter provided an analysis of the displacement results as reported by the active CVN 68 class aircraft carriers. Possible sources for the displacement difference, particularly among the air wing and ammunition load-out, was also discussed. Recommendations for correcting the difference between the modeled and actual displacements were addressed with the most notable recommendation being to conduct an Actual Operating Conditions Displacement Check. The benefits of doing this AOC check were evaluated to include the benefits to ship maintainers as well as the cost savings over the lifetime of the ship.

THIS PAGE INTENTIONALLY LEFT BLANK

LIST OF REFERENCES

- Allen, Thad W., Conway, James T. and Roughead, Gary (2007). *A Cooperative Strategy for 21st Century Seapower*.
- Biran, Adrian (2003). *Ship Hydrostatics and Stability*. Oxford: Butterworth-Heinemann.
- Carey, Robert J. (2007). *Department of the Navy Records Management Program*. Washington, DC: The Department of the Navy Chief Information Officer.
- Commander, Naval Sea Systems Command (1985). *Expanded Ship Work Breakdown Structure for all Ships and Ship/Combat Systems*.
- Comstock, John P., Rossell, Henry E. and Society of Naval Architects and Marine Engineers (U.S.) (1967). *Principles of Naval Architecture. Written by a Group of Authorities. Editor: John P. Comstock*. Rev ed. New York: Society of Naval Architects and Marine Engineers.
- Corretjer, Carlos R. (2005). *CV/CVN Classes Weight & Stability Status*, [PowerPoint handout].
- Corretjer, Carlos R. (2009a). *CVN 68 Class FL Load-out Report*, [PowerPoint handout].
- Corretjer, Carlos R. (2009b). *CVN 68 Stability Status* [PowerPoint handout].
- Federation of American Scientists (2000). *Draft Marks on the Bow and Stern of Vessel*, Federation of American Scientists. Retrieved March 3, 2009 from <http://www.fas.org/man/dod-101/sys/ship/beginner.htm>
- Gates, Robert M. (2008). *The National Defense Strategy*.
- Gillmer, Thomas C., and Johnson, Bruce (1982). *Introduction to Naval Architecture*. Annapolis, Md: Naval Institute Press.
- Guldner, Tom (2002). *Stern Draft Marks*. The Marine Firefighting Institute. Retrieved on March 3, 2009 from <http://www.marinefirefighting.com/Pages/Newsletters/Newsletter2.htm>
- Katz, Jeffery G. (2005). *Photograph of USS Harry S. Truman at Sea*. Retrieved on January 27, 2009 from http://www.navy.mil/view_single.asp?id=877
- MIL-PRF-24647D(SH) (2005). *Performance Specification for Paint Systems, Anticorrosive and Antifouling, and Ship Hull*.

NAVSEAINST 9096.6B (2001). *Policy for Weight and Vertical Center of Gravity Above Bottom of Keel (KG) Margins for Surface Ships.*

NAVSEAINST 9096.3E (2005). *Weights and Moment Compensation and Limiting Drafts for Naval Surface Ships.*

Norfolk Naval Shipyard (1996). *Stability and Weight CVN-68 Class Carriers* [PowerPoint handout].

Rawson, K. J., and Tupper, E. C. (1983). *Basic Ship Theory*. 3rd ed. Harlow, Essex, England; New York; New York: Longman Scientific & Technical; Co-published in the U.S. with John Wiley.

Surface Warfare Officer School. *Principles of Stability*. Retrieved on March 4, 2009 from <http://www.fas.org/man/dod-101/navy/docs/swos/dca/stg4-04.html>

USS Jupiter (AC 3) (1913). Chief of Naval Information. Retrieved January 27, 2009 from <http://www.chinfo.navy.mil/navpalib/ships/carriers/jupiter.jpg>

USS Langley (CV 3) (1922). US Naval Institute Photo Collection. Retrieved February 5, 2009 from <http://www.history.navy.mil/photos/images/h63000/h63545.jpg>

Vieira, Jose G. (2008). *NNSY Input* [PowerPoint handout].

Zubaly, R. B. (1996). *Applied Naval Architecture*. 1st ed. Centreville, Md: Cornell Maritime Press.

INITIAL DISTRIBUTION LIST

1. Defense Technical Information Center
Ft. Belvoir, Virginia
2. Dudley Knox Library
Naval Postgraduate School
Monterey, California
3. ATTN: Mr. Carlos R. Corretjer, Code 244
NAVSEA CADEROCK DIVISION
West Bethesda, Maryland
4. NAVSEA 05V
Commander, Naval Sea Systems Command
Washington Navy Yard, D.C.
5. PMS-312
Commander, Naval Sea Systems Command
Washington Navy Yard, D.C.
6. PMS-312E
Commander, Naval Sea Systems Command
Washington Navy Yard, D.C.