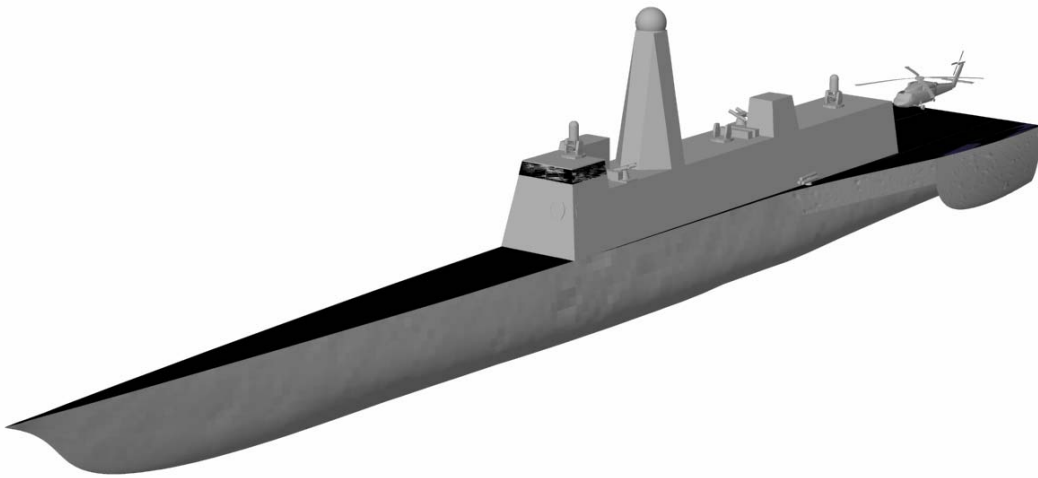


# Focused Mission High Speed Combatant



LT Erik Oller, USN  
LT Vasilios Nikou, HN  
LTJG Konstantinos Psallidas, HN

May 9, 2003  
13.414 Projects in New Construction Naval Ships Design  
Massachusetts Institute of Technology

# Report Documentation Page

Form Approved  
OMB No. 0704-0188

Public reporting burden for the collection of information is estimated to average 1 hour per response, including the time for reviewing instructions, searching existing data sources, gathering and maintaining the data needed, and completing and reviewing the collection of information. Send comments regarding this burden estimate or any other aspect of this collection of information, including suggestions for reducing this burden, to Washington Headquarters Services, Directorate for Information Operations and Reports, 1215 Jefferson Davis Highway, Suite 1204, Arlington VA 22202-4302. Respondents should be aware that notwithstanding any other provision of law, no person shall be subject to a penalty for failing to comply with a collection of information if it does not display a currently valid OMB control number.

1. REPORT DATE <b>09 MAY 2003</b>		2. REPORT TYPE		3. DATES COVERED <b>00-00-2003 to 00-00-2003</b>	
4. TITLE AND SUBTITLE <b>Focused Mission High Speed Combatant</b>				5a. CONTRACT NUMBER	
				5b. GRANT NUMBER	
				5c. PROGRAM ELEMENT NUMBER	
6. AUTHOR(S)				5d. PROJECT NUMBER	
				5e. TASK NUMBER	
				5f. WORK UNIT NUMBER	
7. PERFORMING ORGANIZATION NAME(S) AND ADDRESS(ES) <b>Massachusetts Institute of Technology, Cambridge, MA, 02139</b>				8. PERFORMING ORGANIZATION REPORT NUMBER	
9. SPONSORING/MONITORING AGENCY NAME(S) AND ADDRESS(ES)				10. SPONSOR/MONITOR'S ACRONYM(S)	
				11. SPONSOR/MONITOR'S REPORT NUMBER(S)	
12. DISTRIBUTION/AVAILABILITY STATEMENT <b>Approved for public release; distribution unlimited</b>					
13. SUPPLEMENTARY NOTES					
14. ABSTRACT					
15. SUBJECT TERMS					
16. SECURITY CLASSIFICATION OF:			17. LIMITATION OF ABSTRACT	18. NUMBER OF PAGES	19a. NAME OF RESPONSIBLE PERSON
a. REPORT <b>unclassified</b>	b. ABSTRACT <b>unclassified</b>	c. THIS PAGE <b>unclassified</b>			

## Executive Summary

The Focused Mission High Speed Combatant is designed to conduct Mine Counter Measure Operations, Anti-Submarine Warfare Operations, or operations against small boats in the littoral environment. The ship will extensively utilize unmanned systems such as the VTUAV Firescout, Spartan USV, and LMRS UUV. The ship will also hanger and support SH-60 helicopters. These and most other combat systems will be deployed on the ship in mission-specific configurations of modular packages. Systems not required for the planned mission will not be on board.

The requirements for the Focused Mission High Speed Combatant are listed in Table 1. The designed characteristics for the ship are shown in Table 2. The ship will be able to cross the Atlantic Ocean unescorted, proceed to an area of operations, and perform its mission independently, with other Focused Mission High Speed Combatants, or with other United States or coalition forces.

Key lessons learned in this study include:

1. Speed Costs: \$220 Million dollars is not enough to buy the capabilities required.
2. Trimaran design presents its own unique complications. The placement and size of side hulls has a dramatic effect on speed and on stability. Special consideration must be given to ensuring the design meets damaged stability requirements with one side hull damaged.
3. The launch and recovery of small craft is a major design driver that must be recognized and planned for early in the design process.

**Table 1. Top Level Requirements**

	Threshold	Goal
Top Speed	40 kt	50 kt
Endurance Range at Most Economical Speed	2000 nm	4000 nm
Payload	275 LT	394 LT

**Table 2. Focused Mission High Speed Ship Characteristics**

Total Displacement	3559 lt
Side hull Displacement	27 lt each
Top Speed	41.6 kt
Endurance Speed	19 kt
Endurance Range	3500 nm
Design Payload	364 lt
Draft	4.32 m
Length	148 m
Side hull Length	22.2 m
Main Hull Beam	11.7 m
Side Hull Beam	2.5 m
Overall Beam	21.8 m
Estimated Cost in FY 05 Dollars	\$332.7 Million
Overall Measure of Effectiveness	0.55

# Table of Contents

Executive Summary .....	ii
Table of Contents .....	iii
List of Tables .....	v
List of Figures .....	vi
1. Mission Need .....	1
1.1 Defense Guidance and Policy .....	1
1.2 Adversary Capabilities Analysis .....	1
1.3 Current United States Capabilities Assessment .....	2
1.4 Mission Need .....	2
1.5 Recommended Alternative .....	2
2. Design Requirements and Plan .....	2
2.1 Required Operational Capabilities .....	2
2.2 Concept of Operations/Operational Scenario .....	3
2.2.1 Concept of Operations .....	3
2.2.2 Operational Scenario .....	4
2.3 Goals, Constraints and Standards .....	5
2.3.1 Goals and Thresholds .....	5
2.3.2 Additional Requirements and Constraints .....	5
2.3.3 Design and Builder's Margins .....	6
2.3.4 Payload Requirements .....	6
2.4 Design Philosophy and Decision Process .....	8
2.4.1 Design Philosophy .....	8
2.4.2 Decision Process .....	8
3. Concept Exploration .....	8
3.1 Hull Type Selection .....	8
3.1.1 Development of the Hull Type Comparison Tool .....	9
3.1.2 Analysis of Alternative Hull Types .....	10
3.1.3 Final Hull Type Selection .....	12
3.2 The Design Space Study .....	12
3.2.1 Design of Experiments .....	12
3.2.2 Trimaran Ship Synthesis .....	14
3.2.3 The Pareto Frontier .....	16
3.3 Baseline Concept Design .....	16
3.3.1 Revision of the Baseline Concept Design .....	18
3.3.2 Final Baseline Concept Design .....	18
4. Feasibility Study and Assessment .....	20
4.1 Design Definition .....	20
4.1.1 Ship Geometry .....	20
4.1.1.1 Principal Ship Characteristics .....	20
4.1.2 Arrangements .....	20
4.1.2.1 General Arrangements .....	20
4.1.2.2 Tank Layout .....	24
4.1.2.3 Area and Volume Balance Summary .....	24
4.1.3 Combat System/C4ISR .....	25

4.1.3.1	Combat Systems Arrangements .....	26
4.1.3.2	Arcs of Fire .....	27
4.1.3.3	Sensor Coverage .....	27
4.1.4	Trimaran Hydrostatics .....	28
4.1.4.1	Intact Stability .....	28
4.1.4.2	Damaged Stability .....	33
4.1.5	Trimaran Hydrodynamics .....	36
4.1.5.1	Hydrodynamic Comparison of Hull Forms .....	37
4.1.5.2	Hydrodynamic Effect of Side Hull Configuration .....	37
4.1.5.3	Seakeeping Analysis .....	38
4.1.5.4	Resistance .....	45
4.1.5.5	Propulsion .....	47
4.1.5.6	Electric Load Analysis .....	53
4.1.5.7	Environmental Considerations .....	53
4.1.6	Survivability and Signatures .....	53
4.1.6.1	Susceptibility .....	53
4.1.6.2	Vulnerability .....	54
4.1.6.3	Recoverability .....	54
4.1.7	Manning .....	54
4.1.8	Structural Analysis .....	55
4.1.8.1	Weight Distribution .....	55
4.1.8.2	Midship Section Construction .....	55
4.1.8.3	Structural Analysis of the Hogging and Sagging Loading Cases .....	57
4.2	Cost .....	58
4.3	Risk .....	60
4.4	Operations and Support .....	60
5.	Design Conclusions .....	61
5.1	Summary of Final Concept Design .....	61
5.2	Final Design Assessment .....	63
5.3	Areas for Further Study .....	63
	Acknowledgements .....	64
	Endnotes .....	64

## List of Tables

Table 1. Top Level Requirements.....	ii
Table 2. Focused Mission High Speed Ship Characteristics .....	ii
Table 3. Notional Representative Required Operational Capabilities and Descriptions. ....	3
Table 4. Design Requirement Goals and Thresholds.....	5
Table 5. Additional Requirements and Constraints.....	6
Table 6. Design and Builders Margins. ....	6
Table 7. Payloads Used for Design Space Study.....	7
Table 8. Overall Measure of Effectiveness Inputs.....	8
Table 9. Results of Hull Type Comparison. ....	11
Table 10. Comparison of Catamaran and Trimaran Hull Types.....	12
Table 11. Designs Used to Examine the Design Space. ....	14
Table 12. Cost and OMOE for Each Combination of Parameters.....	15
Table 13. The Baseline Concept Design.....	17
Table 14. Final Baseline Concept Design.....	19
Table 15. Ship Geometry .....	20
Table 16. Required and Allocated Tankages .....	24
Table 17. Weight and Volume Balance Summary.....	25
Table 18. Core Mission Systems. ....	25
Table 19. Modular Mission Systems. ....	26
Table 20. Comparison of 22 m and 44 m Side Hull Designs .....	34
Table 21. Stability Characteristics for Damaged Condition with Main Hull and One Side Hull Damaged.....	35
Table 22: Annual Sea State Occurrences in the Open Ocean, North Atlantic.....	40
Table 23: Limiting Criteria for Personnel Seasickness.....	41
Table 24: Limiting Criteria for Flight Operations .....	41
Table 25: Motions at 30 knots head seas for personnel sea sickness criteria .....	43
Table 26: Motions at 30 knots Head Seas for Flight Operations Criteria.....	44
Table 27: Resistance Data.....	46
Table 28. Major Machinery Plant Components .....	47
Table 29. Machinery Arrangements .....	48
Table 30: Propulsion System Efficiencies .....	48
Table 31. Bending Stress Summary for Hogging and Sagging .....	57
Table 32. Shear and Bending Stress Summary for Hogging and Sagging in the Maximum and Minimum Loading Conditions with Enhanced Structural Components .....	58
Table 33. Fixed Ship Costs Table .....	59
Table 34. Adapted Fixed Ship Costs Table .....	59
Table 35. Inflation and Cost Growth Factors.....	59
Table 36. Calculated Costs for the High Speed Focused Mission Combatant .....	60
Table 37. Final Design Summary .....	62
Table 38. Overall Measure of Effectiveness of Final Design.....	63

## List of Figures

Figure 1. MAPC Interface.....	9
Figure 2. Team 13A Hull Type Comparison Tool Interface. ....	10
Figure 3. Central Composite Design Space. ....	13
Figure 4. Pareto Plot of the Trimaran Designs Used to Explore the Design Space.....	16
Figure 5. Profile of Arrangements .....	22
Figure 6. Main Deck .....	22
Figure 7. First Deck Arrangements.....	23
Figure 8. Second Deck Arrangements .....	23
Figure 9. Third Deck Arrangements .....	23
Figure 10. Tankage Arrangements.....	24
Figure 11. Combat Systems Arrangements .....	26
Figure 12. CIWS Arcs of Fire.....	27
Figure 13. Sensor Arcs of Coverage .....	27
Figure 14: Curves of Form.....	28
Figure 15: Righting Arm at Full Load Condition .....	29
Figure 16: Full Load Righting Arm for Beam Wind and Rolling .....	30
Figure 17: Full Load Condition Righting Arm Curve for High Speed Turn.....	32
Figure 18: Full Load Righting Arm for Personnel Crowding to One Side.....	32
Figure 19: Righting Arm of Minimum Load Condition .....	33
Figure 20. Top View of Damaged Condition with Main Hull and One Side Hull Damaged .....	34
Figure 21. Trim, List, and Righting Arm for Damaged Condition with Main Hull and One Side Hull Damaged.....	35
Figure 22. Top View of Damaged Condition with Main Hull and Both Side Hulls Damaged .....	36
Figure 23. Trim, List, and Righting Arm for Damaged Condition with Main Hull and One Side Hull Damaged .....	36
Figure 24: Trimaran Side Hull Configurations (17) .....	38
Figure 25: Three Dimensional Panel Distribution .....	40
Figure 26: Roll Motion Time History (19knots, quartering seas) .....	42
Figure 27: Responses and Limits at 25 knots .....	43
Figure 28: Response Amplitude Operators for Pitch and Roll @ 12 knots, Head Seas...	44
Figure 29: Resistance Components.....	47
Figure 30. Maximum Speed for Different Values of Form Drag. ....	49
Figure 31: Form Drag Probability Distribution .....	50
Figure 32: Distribution of Total Resistance at 40 knots .....	51
Figure 33: Cumulative Distribution of Total Resistance at 40 knots.....	51
Figure 34: Cumulative Distribution of Total Resistance at 42 knots.....	52
Figure 35: Cumulative Distribution of Total Resistance at 44 knots.....	52
Figure 36. Berthing and Living Spaces.....	55
Figure 37 Midship Section Drawing Generated by ASSET .....	56
Figure 38. Final Midship Section Designed Using in POSSE.....	56
Figure 39. Shear Force and Bending Moment Graph for the Minimum Loading Condition in Hogging .....	58

# **1. Mission Need**

## **1.1 Defense Guidance and Policy**

The unclassified Mission Need Statement (MNS) for the Focused Mission High Speed Combatant, Appendix A, in part addresses the Department of Defense “Defense Planning Guidance, FY 1995-1999,” dated 28 September 1993, requiring the United States to: “...continue to field first rate military forces capable of performing their missions in a wide range of operations,” (p.1) “...capitalize on advanced technology and modernize our weapons and support systems selectively to ensure we retain superior capabilities” (p.14).

The Focused Mission High Speed Combatant must operate wherever required, particularly in littoral waters, to enable joint maritime expeditionary force operations. The mission capabilities must be fully interoperable with other naval, interagency, joint, Coast Guard, and allied forces.

## **1.2 Adversary Capabilities Analysis**

As a result of the 2001 Quadrennial Defense Review, the basis of defense planning has been shifted from a threat-based model to a capabilities-based model. The capabilities-based model focuses on how an adversary might fight instead of who that adversary might be. This model recognizes that planning for large wars in distant theaters is not sufficient. The United States must also plan for adversaries who will rely on surprise, deception, and asymmetric warfare to meet their objectives.<sup>1</sup> Adversary capabilities will expand beyond traditional warfighting and include asymmetric approaches to warfare that employ terrorism and weapons of mass destruction.

In the past, the large distances between adversaries and the United States have provided a significant level of protection. September 11, 2001 illustrates that the United States can no longer rely upon this geographic insulation. The rise of international travel and trade has made even the United States homeland vulnerable to hostile attack.<sup>2</sup>

Those who articulate and develop national strategy need to consider the rise and decline of regional powers. Many of these states are vulnerable to overthrow by radical or extremist internal forces. Some of them have large armies and the capability to possess weapons of mass destruction.<sup>3</sup> In some states, the governments are unable to prevent their territories from serving as sanctuaries for terrorists and criminals who may pose threats to the safety of the United States. In these cases, “threats can grow out of weakness of governments as much as out of their strength.”<sup>4</sup> These threats do not always possess a national identity.

Asymmetric warfare, reduced insulation provided by geographical distances, and vulnerabilities of foreign governments result in the need for the United States to maintain the ability to conduct military operations whenever and wherever necessary for the national defense. The ability to conduct operations and gather intelligence in littoral waters will be a key element in assuring access to all potential areas of military operation.



### **1.3 Current United States Capabilities Assessment**

The United States does not currently have ships designed to assure and maintain access to littoral waters. The deeper draft of traditional multi-mission ships could prevent them from successfully prosecuting shallow draft small craft. The multi-mission ships do not have the speed necessary to pursue high-speed small boats that may oppose United States naval forces. Conventional Mine Counter-Measure (MCM) ships do not have the capability to defend themselves against missile attack. Helicopters can prosecute these small craft in the littorals, but they cannot maintain presence.

### **1.4 Mission Need**

The Focused Mission High Speed Combatant will provide assured access in littoral waters by conducting mine counter-measure missions and anti-submarine warfare missions, as well as prosecuting high speed small craft.

### **1.5 Recommended Alternative**

Potential alternatives include:

- New conventional ship designs.
- A modified repeat DDG-51.
- Advanced/unconventional hull type designs.
- Modular ship designs using one of the alternatives above.

The recommended alternative is a modular ship design using an unconventional or conventional hull type. The draft of the DDG-51 is too deep for successful littoral operations and this more valuable multi-mission asset may be better employed further from the littoral areas of operation. The modular ship design would allow for one ship to be able to perform several different types of missions based upon the module on board. Equipment for missions not being performed would not occupy valuable space and volume on the ship.

## **2. Design Requirements and Plan**

### **2.1 Required Operational Capabilities**

All United States Navy and Coast Guard combat vessels are designed to perform one or more of the Naval Warfare Mission Areas defined by OPNAVINST C3501.2J, Naval Warfare Mission Areas & Required Operational Capabilities and Projected Operational Environment (ROC/POE) Statements, dated 31 May 1996.<sup>5</sup> The Naval Warfare Mission Areas are divided into operational capabilities that are further divided into sub-operational capabilities. For example, the Naval Warfare Mission Area of Anti-Air Warfare (AAW) contains operational capabilities such as AAW 1 – Provide air defense independently or in cooperation with other forces, and AAW 4 – Conduct air operations to support airborne anti-air operations. AAW 1 contains sub-operational capabilities such as AAW 1.1 - Provide area defense for a battle group (BG), and AAW 1.2 – Conduct air self-defense using missile, gun, electronic or physical systems (e.g., chaff, flares). Operational capabilities are used to assess material, personnel, supply and training readiness and to develop manpower requirements.

Table 3 presents a notional, representative list of required operational capabilities for the Focused Mission High Speed Combatant.

**Table 3. Notional Representative Required Operational Capabilities and Descriptions.**

ROC's	Description
AAW 1.2	Provide unit self-defense.
AMW 6	Conduct day and night helicopter, Short/Vertical Take-off and Landing and airborne autonomous vehicle (AAV) operations.
AMW 6.7	Serve as a helo haven.
AMW 14.6	Conduct spotting for Naval gunfire and artillery.
ASU 1.10	Conduct close-in surface self-defense using crew operated machine guns.
ASU 4	Detect, identify, localize, and track surface ship targets.
ASW 1	Provide ASW defense against submarines for surface forces, groups and units.
C4I 3	Provide own unit's C4I functions.
SEW 2	Conduct sensor and ECM operations.
SEW 3	Support sensor and ECCM operations.
FSO 6	Conduct SAR operations.
INT 1	Conduct intelligence collection.
MIW 4	Conduct mine countermeasures (avoidance).
MOB 1	Steam to design capability in most fuel efficient manner.
MOB 3	Prevent and control damage.
MOB 5	Maneuver in formation.
MOB 7	Perform seamanship, airmanship and navigation tasks (navigate, anchor, mooring, scuttle, life boat/raft capacity, tow/be towed).
MOB 10	Replenish at sea.
MOB 12	Maintain health and well being of crew.
NCO 3	Provide upkeep and maintenance of own unit.
NCO 19	Conduct maritime law enforcement operations.

## 2.2 Concept of Operations/Operational Scenario

### 2.2.1 Concept of Operations

This concept of operations is based upon the Mission Need Statement for the Focused Mission High Speed Combatant. The ship is envisioned to be a networked, agile, stealthy surface combatant capable of defeating anti-access and asymmetric threats in the littorals. This ship will complement our Aegis fleet, DD(X), and CG (X) by operating in environments where it is less desirable to employ larger, more valuable multi-mission ships. Additionally, it will have the capability to operate cooperatively with the United States Coast Guard and other allies. The Focused Mission High Speed Combatant will have the capability to deploy independently to overseas littoral regions, to remain on station for extended periods of time either with a battle group or through a forward basing arrangement, and to conduct underway replenishment. It will operate with Battle Groups,

Expeditionary Strike Groups, Maritime Expeditionary Forces, in groups of other similar ships, or independently for diplomatic and presence missions.

It is envisioned that the ship will rely heavily on manned and unmanned consort vehicles to execute assigned missions and operate as part of a netted, distributed force. In order to conduct successful combat operations in an adverse littoral environment, it must employ technologically advanced weapons, sensors, data fusion, Command, Control, Computing, Communications, Intelligence, Surveillance, Reconnaissance, and Targeting (C4ISR-T), smart control systems, and self-defense systems.

The Focused Mission High Speed Combatant will be among the first naval forces to arrive in the region. It will perform detailed reconnaissance of topography, gather intelligence, and search for mines or submarines. As hostilities intensify, the Focused Mission High Speed Combatant may be required to clear mines and support Special Operations Forces (SOF) evolutions. The Focused Mission High Speed Combatant may be required to escort Amphibious Ready Groups, MCM Groups, or replenishment groups. The ship may be required to steam independently or in groups to conduct Anti-Submarine Warfare (ASW) or MCM operations.

### 2.2.2 Operational Scenario

In a hypothetical operational scenario, country Red is known to harbor and support a terrorist group wanted by the United States and allied nations. This terrorist group is known to have conducted operations against civilian and military targets in several Western nations. The United States and its allies are attempting to take the terrorist leaders into custody through diplomatic channels. In anticipation of possible military action, United States forces begin to prepare for deployment.

Naval forces can only access Red territory from a shallow gulf south of Red. The entrance to the gulf is through a narrow strait. Naval forces must transit through the strait in order to reach the gulf and project power into Red territory. Intelligence reports indicate that Red anti-ship missile batteries have deployed to unknown locations along the strait, and Red's three diesel submarines are not in port. Red is also known to possess and use mines.

A task force of twelve Focused Mission High Speed Combatants and a Naval Expeditionary Force are sent to the Area of Operations. The task force consists of three groups of four ships each. Group A is configured for MCM and is ahead of the task force. Group A uses Long-Term Mine Reconnaissance System (LMRS) and Remote Minehunting System (RMS) to detect mines along the projected route of task force. Group B is configured for C4ISR and travels with the task force. Group B uses Vertical Takeoff Unmanned Aerial Vehicles (VTUAV's) and Spartan Unmanned Surface Vehicles (USV's) to patrol in search of Red forces. Group C is configured for ASW and is stationed to support the task force. Group C uses MH-60 helicopters with dipping sonars and sonobuoys to locate Red submarines.

Diplomatic efforts prove futile. National Command Authority directs United States forces to conduct operations necessary to effect a regime change in Red and destroy the terrorist group.

As the task force approaches the Area of Operations, VTUAV's from the C4ISR group locate four missile batteries and several other Red positions. The precise locations are transmitted to the Naval Expeditionary Force that launches missiles to destroy the

Red forces. As the task force nears the Area of Operations, a VTUAV from the C4ISR group detects a snorkeling submarine, and an LMRS detects and identifies another Red submarine near a minefield. The ASW group identifies and prosecutes the Red submarines using sonobuoys and helicopter-launched torpedoes. The ASW group verifies that the area near the minefield is clear of submarines and continues to search for the remaining Red submarine.

The MCM group sweeps a channel through the minefield, and the Naval Expeditionary Force begins movement through the channel. USV's from the C4ISR group detect several fast small craft emerging from hidden locations along the Red coast and proceeding toward the United States forces. Four Focused Mission High Speed Combatants proceed to intercept and destroy the incoming craft before they can threaten the Expeditionary Force.

After the Red small craft are destroyed, the task force reforms to escort the Naval Expeditionary Force to the next Area of Operations.

### 2.3 Goals, Constraints and Standards

#### 2.3.1 Goals and Thresholds

Table 4 presents the desired performance and capabilities of the vessel and the metrics used to measure them.

**Table 4. Design Requirement Goals and Thresholds.**

Measure of Performance	Goal	Threshold	Metric
Top Speed	50	40	Knots
Endurance Range at Best Speed	4000	2000	Nm
Aviation Capability	Capable of supporting any one of: 2 AH-58D or 1 SH-60 or 3 VTUAV's	Capable of supporting any one of: 2 AH-58D or 3 VTUAV's	
Modularity	Modularity for mission and for upgradeability	Modularity for mission	
Endurance Duration/Stores	Dry: 45 Chilled: 30 Frozen: 45 General: 45	Dry: 30 Chilled: 25 Frozen: 30 General: 30	Days

#### 2.3.2 Additional Requirements and Constraints

The Mission Need Statement establishes several additional requirements and constraints. They are presented in Table 5.

**Table 5. Additional Requirements and Constraints.**

Navigational Draft	20 feet maximum
Fuel System	Non-compensating fuel tanks preferred
Total Lead Ship Acquisition Cost Goal	\$220M FY-05 <sup>a</sup>
Crew	Mixed gender

2.3.3 Design and Builder's Margins

**Table 6. Design and Builders Margins.**

Margin		Metric
Weight	10%	Displacement
KG	0.5	Ft
Space Margin	5%	
Passageway Margin	5%	
Tankage Margin	5%	
Electrical Margins		
- Design	20%	
- Service Life	20%	
A/C Margin	20%	

2.3.4 Payload Requirements

The Focused Mission High Speed Combatant will be designed to support a variety of payloads through modularity. Mission payload systems include: C4ISR-T, Weapons, and Organic Off-board Vehicle systems required to perform the ship missions. Some systems will be permanently installed on the host vessel, but most systems will be modular and will only be installed when required for the assigned mission.

In order to determine the required payload capacity of the ship, the design team designed payloads for each of the major mission areas and found that the anti-submarine warfare payloads were the heaviest. The team designed several additional payloads for the ASW mission area in order to be able to conduct a thorough study of the design space. The team also designed a bare minimum payload. The minimum payload weighs 275 lton. Table 7 presents the major payload items and the total payload weights.

---

<sup>a</sup> The Lead Ship Acquisition Cost does not include the modular mission systems or the cost of the aviation assets.

**Table 7. Payloads Used for Design Space Study.**

	275 LT	334 LT	364 LT	394 LT
System	Qty	Qty	Qty	Qty
COMMAND AND CONTROL SYSTEMS	1	1	1	1
Communication System	1	1	1	1
Cooperative Engagement Capability (CEC)	1	1	1	1
AIEWS Phase I - AN/SLQ-32(V)3	1	1	1	1
SPY-1K Planar Array Radar	1	1	1	1
AN/SPQ-9( ) Radar	1	1	1	1
MK 99 Fire Control Sys w/3 SPQ-62 Directors	1	1	1	1
Underwater Fire Control - DDG & Above (DDG 51 Data)	0	0	1	1
Surface Search Radar - AN/SPS-64	1	1	1	1
1X MK 16 CIWS Gun Mount	1	2	2	2
1X MK 19 40mm Gun with 2500 rds ammo	0	1	2	2
MK XII AIMS IFF	1	1	1	1
RAM LAUNCHER - 8 CELL RALS - 8 Rdy Srv and 21 Magazine	1	1	1	1
AGM-114M Hellfire II Surf-to-Surf Missile Sys Crossbow Launcher w/ 2 missiles	0	1	2	2
AGM-119B Penguin Surf-to-Surf Missile Sys (Mk 2 Mod 7N) Launcher w/ 6 missiles	0	3	3	6
6X-MK 137 - Rdy Srv 12 Nulka, 36 SRBOC - Magazine 12 Nulka, 200 SRBOC	1	1	1	1
MFTA MULTI FUNCTION TOWED ARRAY	0	1	1	1
2X-Enclosed Mk 32 MOD 9 Dual Tube SVTTs and 22 MK 50 Magazine	0	0	1	1
Offboard Vehicle Package	Basic	Full	Full	Full
Single SH-60R Det + Hangar + Support	1	1	1	1
Aviation Magazine - (12) MK46 - (24) HELLFIRE - (6) PENQUIN	1	1	1	1
Aviation Fuel	50	50	49.7	75
RAST	1	1	1	1
Total Weight in Itons	275.2	333.85	363.6	393.6
Total Modular Payload & Offboard Vehicles Weight in Itons	178.9	224.35	249.3	279.1
Total Non-Modular Payload Weight in Itons	96.3	109.5	114.3	114.5

The offboard vehicle packages for the ASW mission are composed of a variety of vehicles including RIB's (Rigid Hull Inflatable Boats), Spartan USV's, and DADS (Deployable Autonomous Distributed Systems).

## 2.4 Design Philosophy and Decision Process

### 2.4.1 Design Philosophy

The purpose of this study is to explore the range of options for Focused Mission High Speed Combatants within the \$220M Total Lead Ship Acquisition Cost goal, and to develop a concept design for the best option. The design philosophy consists of several principles:

- A. The ship should meet the cost goal of \$220M in FY-05 dollars.
- B. The ship must use technology that exists currently or will definitely be ready for deployment in 2005.
- C. The ship design will maximize use of Commercial-Off-the-Shelf (COTS) technology to reduce cost and to reduce deployment risk.
- D. The primary goal for modularity is to allow for rapid changes in the ship's mission-related equipment. The secondary goal for modularity is to allow for modernization.
- E. The ship design will be transformational without ignoring standard practices and fleet-wide commonality of design. The design study will examine the use of both traditional and advanced hull types and materials.

### 2.4.2 Decision Process

The Analytic Hierarchy Process (AHP) was used to evaluate the designs. The Overall Measure of Effectiveness (OMOE) was calculated for each design. OMOE is a number between 0 and 1 that reflects how well a design meets the design goals and thresholds. The closer a design's OMOE is to 1 the better the design is. An OMOE of 1 indicates the design meets all goals. An OMOE of 0 indicates the design meets all threshold requirements.

Each factor used in determining OMOE is given a goal value, a threshold value, and a weight. The goals and thresholds are based upon the requirements. The weights are based upon surveys of members of the Surface Warfare community. The surveys and a further discussion of the analysis of the surveys are included as Appendix B. The goals, thresholds and weights for the simplified model employed in the Hull Type Comparison Tool are shown in Table 8.

**Table 8. Overall Measure of Effectiveness Inputs.**

Measure of Performance	Goal	Threshold	Weight
Payload (lton)	394	275	0.38
Speed (kt)	50	40	0.34
Range (nm)	4000	2000	0.28

## 3. Concept Exploration

### 3.1 Hull Type Selection

The team analyzed various hull types to determine which hull type best meets the requirements for the Focused Mission High Speed Combatant. The first step in the analysis was to develop a Hull Type Comparison Tool for rapidly comparing various hull

types given identical requirements. Next, the results of the Hull Type Comparison Tool calculations were analyzed to remove from consideration any hull types that did not meet the requirements. The remaining hull types were compared and the trimaran hull type was selected.

### 3.1.1 Development of the Hull Type Comparison Tool

The team developed a Hull Type Comparison Tool based upon an existing spreadsheet developed by the Maritime Applied Physics Corporation. This spreadsheet tool, commonly known as MAPC, uses parametric models and scaling to create high level designs of various hull types. The inputs are desired speed, range, payload, sea state and maximum displacement; speed, range and payload are given priorities of 1, 2, or 3. A sample interface is presented as Figure 1.

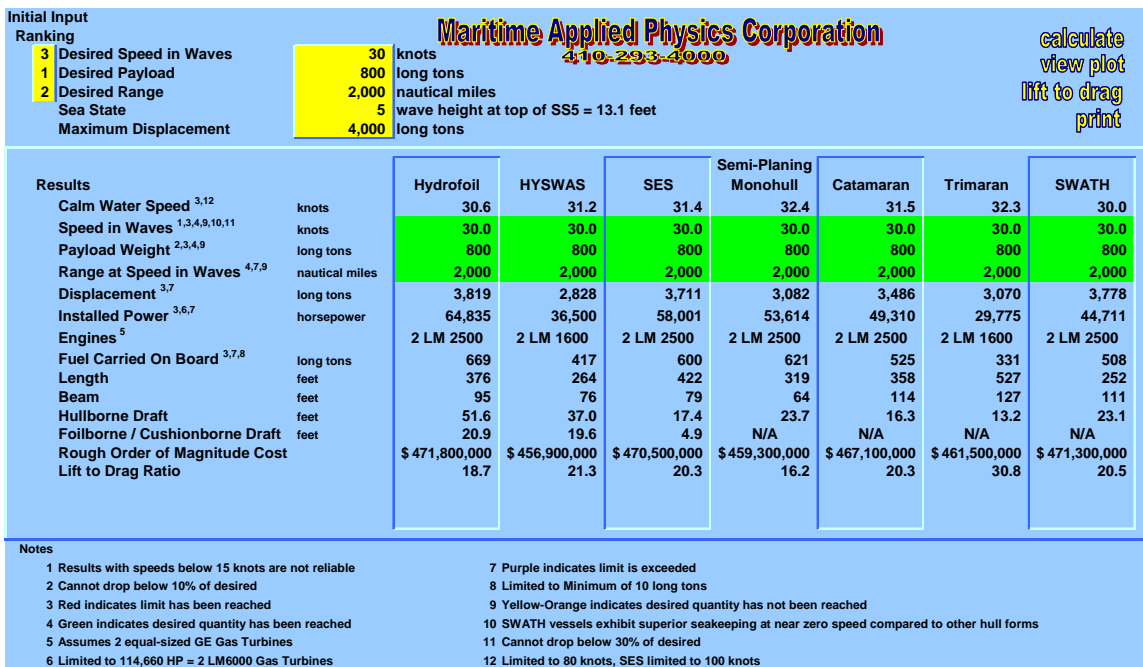


Figure 1. MAPC Interface.

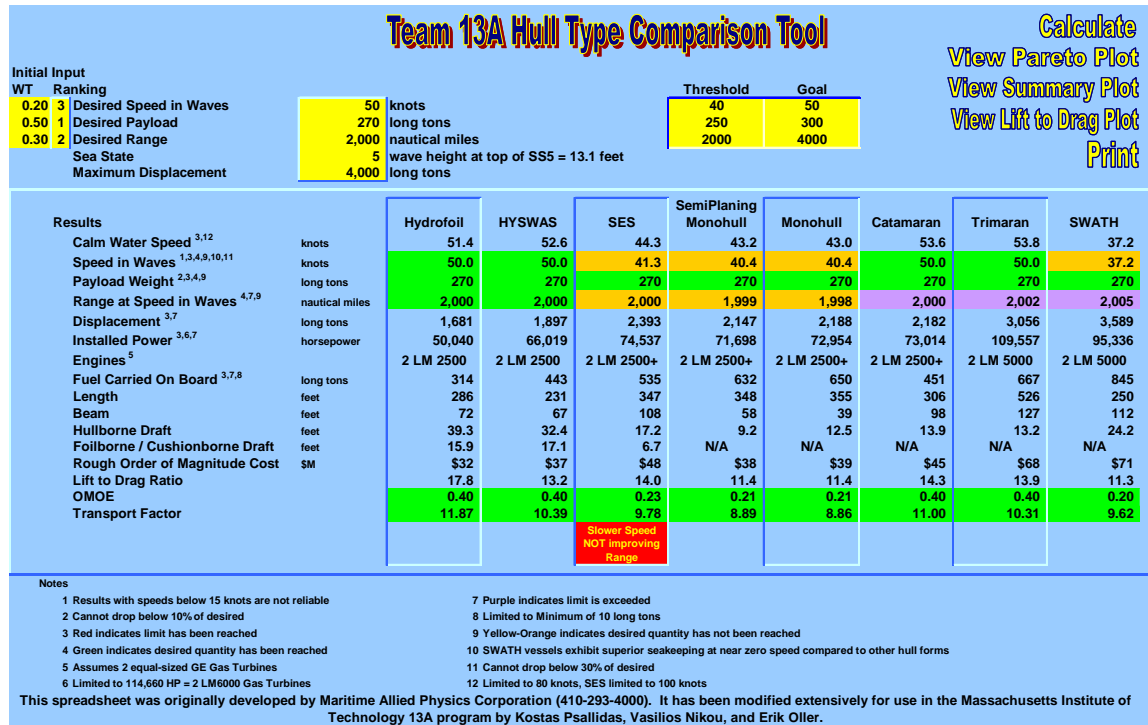
MAPC uses a primary basis vessel for each hull type to provide the block coefficient and the ratios of length to beam and beam to draft. Additional basis vessels are used to derive resistance and powering data. Historical parametric data is used to determine speed loss in waves and weight fractions.

First, the team added the capability to perform calculations for a traditional monohull vessel. This was done to ensure the full range of hull types would be represented in the comparison.

Next, the team performed a literature search to determine the state of the industry for high speed ships and to determine whether the basis vessels used by MAPC represented the current state of the industry. Few high speed vessels have been built with over 2000 LT of displacement, so little data on existing vessels is available. There are many designs, however, so some basis vessels used by the tool are designs that have not been built. Actual vessel data was used wherever possible.



Then, the design team evaluated the equations and algorithms used by MAPC. Finally, the team modified MAPC to meet its needs. The team added the ability to calculate and plot OMOE based upon user-input weights, goals and thresholds for speed, range, and payload. The cost model was adjusted to reflect standard naval practices in determining ship cost for future years. The team also added the calculation of Transport Factor.<sup>b</sup> The final interface is shown as Figure 2.



**Figure 2. Team 13A Hull Type Comparison Tool Interface.**

### 3.1.2 Analysis of Alternative Hull Types

The Hull Type Comparison Tool was used to determine which hull types were most suitable. The data from Table 8 was entered as well as estimated payload weight. The results are summarized in Table 9.

<sup>b</sup> The Transport Factor (TF) is a non-dimensional relationship between weight, design speed, and installed power of a vehicle given by  $TF = \frac{K_2 * W}{(SHPTI / K_1 * V_K)}$  where  $K_1 = 1.6878/550$  hp/lb-knot,  $K_2 = 2240$  lb/LT, W is Displacement in long tons, SHPTI is installed propulsion and lift power, and  $V_K$  is design speed in knots. For a further explanation, please see Colen Kennell, "Design Trends in High-Speed Transport", Marine Technology, Vol. 35, No. 3, July 1998, pp. 127-134.

**Table 9. Results of Hull Type Comparison.**

		Hydrofoil	HYSWAS	SES	SemiPlaning Monohull	Monohull	Catamaran	Trimaran	SWATH
Calm Water Speed <sup>3,12</sup>	knots	51.3	52.3	53.5	54.1	53.5	53.0	53.1	50.0
Speed in Waves <sup>1,3,4,9,10,11</sup>	knots	50.0	50.0	50.0	50.0	49.1	50.0	49.4	50.0
Payload Weight <sup>2,3,4,9</sup>	long tons	394	394	394	394	394	394	394	394
Range at Speed in Waves <sup>4,7,9</sup>	nautical miles	2,000	2,000	1,070	422	26	2,000	2,000	61
Displacement <sup>3,7</sup>	long tons	2,223	2,344	2,526	1,665	1,365	2,701	3,493	1,875
Installed Power <sup>3,6,7</sup>	horsepower	62,648	75,754	114,660	114,660	114,660	84,002	114,654	114,660
Engines <sup>5</sup>		2 LM 2500	2 LM 2500+	2 LM 6000	2 LM 6000	2 LM 6000	2 LM 5000	2 LM 6000	2 LM 6000
Fuel Carried On Board <sup>3,7,8</sup>	long tons	391	505	369	161	10	517	706	23
Length	feet	314	248	353	319	303	328	550	201
Beam	feet	79	71	110	53	33	105	133	90
Hullborne Draft	feet	43.1	34.7	17.5	8.4	10.7	14.9	13.8	19.5
Foilborne / Cushionborne Draft	feet	17.5	18.4	6.8	N/A	N/A	N/A	N/A	N/A
Rough Order of Magnitude Cost	\$M	\$42	\$44	\$63	\$50	\$48	\$54	\$74	\$59
Lift to Drag Ratio		18.8	14.2	11.7	6.8	5.5	15.3	15.0	6.6
OMOE		0.81	0.81	0.73	0.72	0.70	0.81	0.80	0.72
Transport Factor		12.50	11.11	8.10	5.40	4.38	11.72	11.11	5.62

### 3.1.3 Final Hull Type Selection

The first step in final hull type selection was to remove from consideration any hull types that exceeded the 20 ft draft limitation. This removed the hydrofoil and HYSWAS from consideration. The catamaran and trimaran were the only hull types capable of carrying the goal payload at the goal speed for at least the minimum range, so they were the two finalist hull forms.

The catamaran and trimaran hull types were both suitable for the baseline concept design, so their characteristics were compared to find the better one. The trimaran has better seakeeping, good arrangeable space, and can make better speed due to smaller wave interaction effects and less wavemaking resistance. Table 10 summarizes the comparison. The trimaran was selected for the final hull type.

**Table 10. Comparison of Catamaran and Trimaran Hull Types.**

	Catamaran	Trimaran
Seakeeping	Poor at all speeds.	Better at all speeds.
Payload	Large arrangeable space	Large arrangeable space
Speed	High resistance penalty due to hull interaction effects.	Smaller hull interaction effects and less wavemaking resistance.

## 3.2 The Design Space Study

### 3.2.1 Design of Experiments

Once the hull type was selected, it was necessary to find the combination of payload, speed and range that would result in the highest overall measure of effectiveness. The design team used the Central Composite Method of Design of Experiments to determine which combinations would best represent the entire design space.

Design of Experiments (DOE) formalizes and systematizes the design process by creating a design space of consistently defined variants. The designer can use statistical analysis to estimate the effect of each factor and their interactions on the response<sup>6</sup>. One of the most common DOE reduction methods is the Central Composite Design Method.

The Central Composite or Box-Wilson Design is a three- or five-level design that includes the corner, center, and axial points of the design space. The three-factor Central Composite Design space is shown in Figure 3.

The three factor design space is developed from 15 point designs: a center point design, eight corner point designs, and 6 axial point designs. This model provides data to characterize the response surface more accurately than most other methods since the corner points are included. Corner points represent the limits of our design space. This model is also useful when screening designs are used, since the screening design inputs can be re-used to help create the Central Composite design space. However, attempting to reach these corner point designs may strain the engineering model<sup>7</sup>. Table 11 shows the designs which were used to examine the design space.

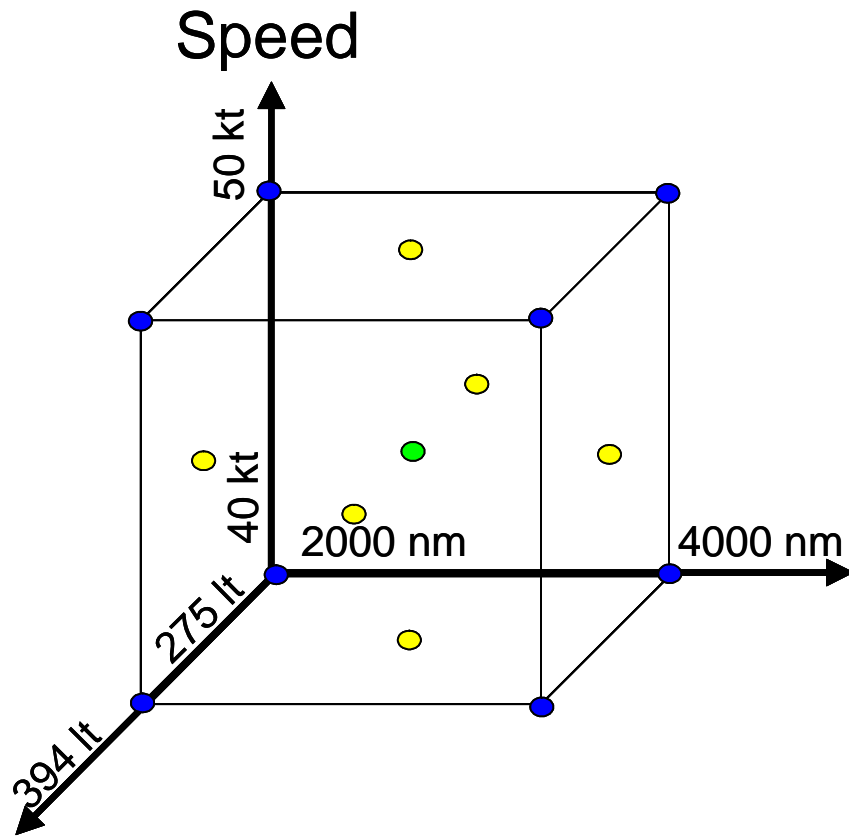


Figure 3. Central Composite Design Space.

**Table 11. Designs Used to Examine the Design Space.**

<b>Design Number</b>	<b>Payload</b>	<b>Range</b>	<b>Speed</b>
1	363.7	3500	40
2	393.6	4000	40
3	333.8	3000	50
4	393.6	3000	50
5	363.7	4000	45
6	363.7	3500	45
7	363.7	3000	45
8	393.6	3000	40
9	363.7	3500	50
10	393.6	4000	50
11	333.8	4000	50
12	393.6	3500	45
13	333.8	3500	45
14	333.8	3000	40
15	333.8	4000	40
16	363.7	3500	45
17	275	4000	50
18	275	3000	45
19	275	2000	50
20	275	2000	40
21	275	4000	40
22	334.5	4000	45
23	334.5	3000	45
24	334.5	2000	45
25	334.5	3000	45
26	394	2000	40
27	394	2000	50
28	394	3000	45
29	394	4000	50
30	394	4000	40
31	334.5	3000	50
32	334.5	3000	40

### 3.2.2 Trimaran Ship Synthesis

In order to facilitate our ship design process the team used a tool being developed by the High Speed Sealift Innovation Cell at the Carderock Division of the Naval Sea Systems Command. This tool, known as the Displacement Hull Design Tool, is an Excel file consisting of 82 different worksheets and occupying over six megabytes of computer memory. The design team used it to estimate the general characteristics of the trimarans that would have the payload, speed and range combinations identified using the Central Composite Method. The team also developed a few additional designs to examine some combinations of parameters that were not included in the Central Composite Method. Table 12 contains the key characteristics of each design.

When the cost and OMOE was estimated for each of the designs, the team found that they all exceeded the \$220 million cost goal. Designs A, B, C were developed in order to examine the capabilities of a ship that would be available for lower costs. It is important to note that the designs with negative OMOE's would be better developed in a monohull design.

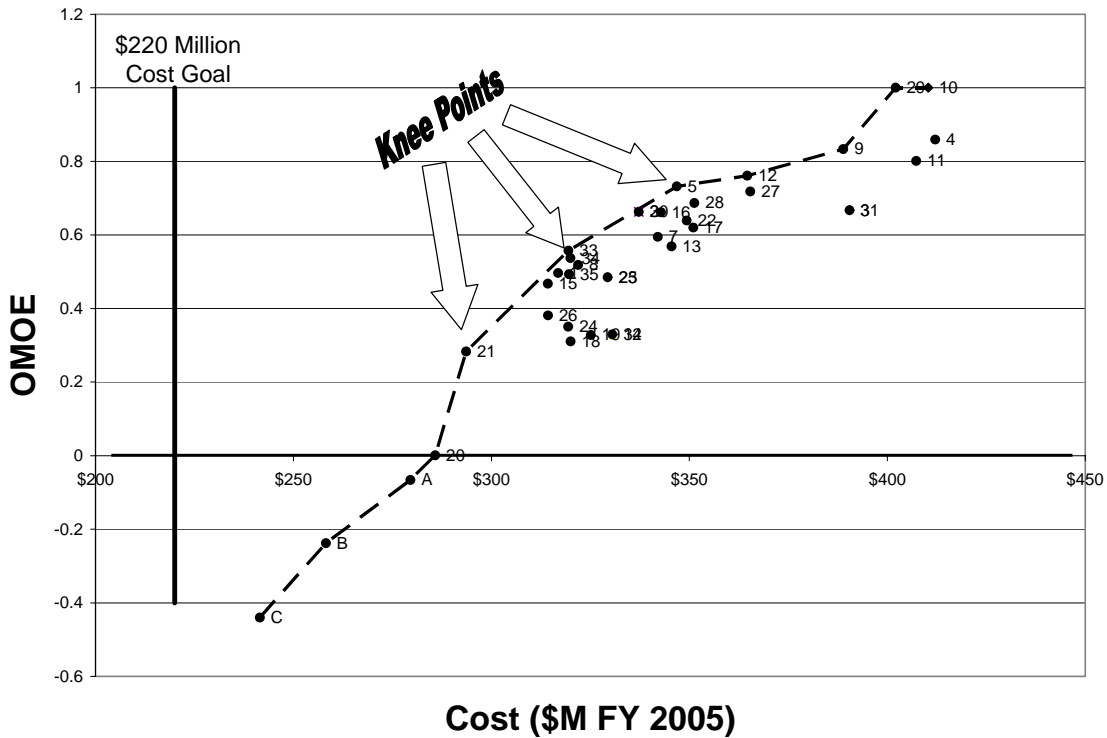
**Table 12. Cost and OMOE for Each Combination of Parameters.**

Design Number	Cost	OMOE	Payload	Range	Speed
1	\$317	0.496	363.7	3500	40
2	\$337	0.663	393.6	4000	40
3	\$390	0.667	333.8	3000	50
4	\$412	0.859	393.6	3000	50
5	\$347	0.732	363.7	4000	45
6	\$349	0.665	363.7	3500	45
7	\$342	0.594	363.7	3000	45
8	\$322	0.519	393.6	3000	40
9	\$389	0.833	363.7	3500	50
10	\$410	1.000	393.6	4000	50
11	\$407	0.801	333.8	4000	50
12	\$365	0.761	393.6	3500	45
13	\$346	0.569	333.8	3500	45
14	\$331	0.330	333.8	3000	40
15	\$314	0.468	333.8	4000	40
16	\$343	0.662	363.7	3500	45
17	\$351	0.620	275	4000	50
18	\$320	0.310	275	3000	45
19	\$325	0.328	275	2000	50
20	\$286	0.001	275	2000	40
21	\$294	0.283	275	4000	40
22	\$349	0.639	334.5	4000	45
23	\$329	0.485	334.5	3000	45
24	\$319	0.351	334.5	2000	45
25	\$329	0.485	334.5	3000	45
26	\$314	0.381	394	2000	40
27	\$365	0.718	394	2000	50
28	\$351	0.687	394	3000	45
29	\$402	1.000	394	4000	50
30	\$337	0.663	394	4000	40
31	\$390	0.667	334.5	3000	50
32	\$331	0.330	334.5	3000	40
33	\$319	0.557	363.7	3500	41.8
34	\$320	0.537	363.7	3500	41.2
35	\$320	0.493	363.7	3500	41.2
A	\$280	-0.066	275	1500	40
B	\$258	-0.238	275	1500	35
C	\$242	-0.440	275	1500	29

### 3.2.3 The Pareto Frontier

A Pareto plot is a plot of OMOE against cost and is a useful tool for evaluating the relative quality of many designs. In general, the best designs have the highest OMOE for the lowest cost and are toward the upper left of the plot. Figure 4 is the Pareto plot for our design space. The 39 designs are represented by black dots. The vertical line represents the cost goal of \$220 million. The dashed line represents the Pareto frontier. The frontier represents the best OMOE obtainable for the cost. Design of Experiments ensures that the design space is fully represented and careful design ensures that the designs on the frontier are in fact the best designs for the cost.

The determination of which design to pursue in greater detail is heavily based upon the cost goal and any points at which improvement in OMOE requires a greater increase in cost. If the cost goal curve intersects the frontier, the design with the highest OMOE within the cost goal is very likely to be selected. In our case, however, no designs fell within the cost goal. The team decided to look at those designs that represented knee points in the Pareto frontier. These knee points indicate that the rate of investment required to improve OMOE rises. Knee points in Figure 4 are indicated by arrows. The sponsor was interested in examining Design 33, at the middle knee point, so that design was selected as the Baseline Concept Design for our study.



**Figure 4. Pareto Plot of the Trimaran Designs Used to Explore the Design Space.**

### 3.3 Baseline Concept Design

Table 13 presents the key parameters of the Baseline Concept Design.

**Table 13. The Baseline Concept Design.**

<b>Ship Particulars</b>			
LBP			143 m
Beam (Overall)			21.8 m
Beam (main hull)			11.7 m
Draft			4.32 m
Depth			10.4 m
Displacement (Total)			3,437 mton
Cb (main hull)			0.47
Cp (main hull)			0.66
Sidehull length			21.45 m
Sidehull beam			2.5 m
Sidehull draft			2.0 m
Cl to Cl hull separation			9.65 m
Sidehull Disp. (each)			26 mton
<b>Powering</b>			
Boost Installed			51,156 kW
Endurance Installed			5,331 kW
Service Installed			2,865 kW
Total Installed			59,352 kW
<b>Machinery Data</b>	<b>Type</b>	<b>Number</b>	<b>Engine</b>
Main Engines	GT	2	GE LM2500+
Secondary Engines	Diesel	2	MTU/DDC 16V-4000 M90
Service Engines	Diesel	3	CaterPillar 3512
<b>Performance Characteristics</b>			
Boost Speed / in waves	41.8 kts		41.2 kts
Froude Number (Boost)	0.58		
Endurance Speed/Achieved	18.8 kts		19.1 kts
Range	3,500 nm		
Range @ Boost Speed	929 nm		
<b>Weights</b>			
Full Load	3,440 mton		
Military Payload	364 mton		
<b>Cost Analysis</b>			
Total Structural Cost	\$146,368,621		
Non-Modular Payload Cost	\$36,347,400		
<b>Total</b>	<b>\$182,716,021</b>		
Design and Planning	<b>\$73,086,409</b>		
Cost Growth	\$27,407,403		
Change Orders	\$9,135,801		
<b>TLSAC Before Inflation</b>	<b>\$292,345,634</b>		
<b>TLSAC After Inflation</b>	<b>\$319,453,968</b>		
<b>OMOE Analysis</b>			
Speed Effect	0.061		
Range Effect	0.212		
Payload Effect	0.285		
<b>OMOE</b>	<b>0.557</b>		

The overall measure of effectiveness for the Baseline Concept Design is significantly lower than the 0.8 predicted by the Hull Type Comparison Tool in the hull type selection process. This is the result of the improved modeling provided by the Displacement Hull Design Tool and is an indicator that the Hull Type Comparison Tool can be significantly



improved. The Hull Type Comparison Tool is, however, an adequate tool to assess the relative characteristics of the various hull types.

### 3.3.1 Revision of the Baseline Concept Design

Once the Baseline Concept Design was developed, the team decided to verify that the requirements used in developing that design were correct. Analysis showed that improvement of the electrical power requirements model was required, so the team made the necessary improvements and modified the Baseline Concept Design to meet the new, greater power requirement.

At this time a Request for Proposals for Preliminary Design Work for the Littoral Concept Ship was issued by NAVSEA. This Request for Proposals had a slightly different set of requirements than the Ship Concept Study had, and slight modifications were made to the requirements used for this project. The modifications we adopted included reduction in berthing to 75 accommodations and reduction in the endurance stores period to 21 days. The necessary adjustments were made to the design to result in a Final Baseline Concept Design. This change in requirements is not believed to have any effect on the results of the relative hull type comparison.

### 3.3.2 Final Baseline Concept Design

Table 14 contains the key parameters of the Final Baseline Concept Design.

**Table 14. Final Baseline Concept Design.**

<b>Ship Particulars</b>				
LBP			148 m	
Beam (Overall)			21.8 m	
Beam (main hull)			11.7 m	
Draft			4.32 m	
Depth			10.1 m	
Displacement (Total)			3,559 mton	
Cb (main hull)			0.47	
Cp (main hull)			0.66	
Sidehull length			22.2 m	
Sidehull beam			2.5 m	
Sidehull draft			2.0 m	
CI to CI hull separation			9.65 m	
Sidehull Disp. (each)			27 mton	
<b>Powering</b>				
Boost Installed			51,156 kW	
Endurance Installed			5,331 kW	
Service Installed			5,370 kW	
Total Installed			61,857 kW	
<b>Machinery Data</b>		<b>Type</b>	<b>Number</b>	<b>Engine</b>
Main Engines		GT	2	GE LM2500+
Secondary Engines		Diesel	2	MTU/DDC 16V-4000 M90
Service Engines		Diesel	4	CaterPillar 3516B
<b>Performance Characteristics</b>				
Boost Speed / in waves			41.9 kts	41.4 kts
Froude Number (Boost)			0.57	
Endurance Speed/Achieved			18.9 kts	19.0 kts
Range			3,500 nm	
Range @ Boost Speed			991 nm	
<b>Weights</b>				
Full Load			3,565 mton	
Military Payload			364 mton	
<b>Cost Analysis</b>				
Total Structural Cost			\$153,950,085	
Non-Modular Payload Cost			\$36,347,400	
<b>Total</b>			<b>\$190,297,485</b>	
Design and Planning			<b>\$76,118,994</b>	
Cost Growth			\$28,544,623	
Change Orders			\$9,514,874	
<b>TLSAC Before Inflation</b>			<b>\$304,475,975</b>	
<b>TLSAC After Inflation</b>			<b>\$332,709,119</b>	
<b>OMOE Analysis</b>				
Speed Effect			0.064	
Range Effect			0.212	
Payload Effect			0.285	
<b>OMOE</b>			<b>0.560</b>	

## 4. Feasibility Study and Assessment

### 4.1 Design Definition

#### 4.1.1 Ship Geometry

##### 4.1.1.1 Principal Ship Characteristics

Table 15 lists the major characteristics of the ship geometry. The geometry is based upon designs created at the Naval Surface Warfare Center Carderock Division in studies of high speed sealift technology.<sup>8,9</sup> The Series 64 hull form was chosen for the main hull and the side hulls in order to meet the demand for a fast ship. The separation between the main hull and the side hulls was chosen to reduce the interference effects. The length of the side hulls was chosen to minimize wetted surface drag while still providing the necessary stability. The longitudinal position of the side hulls was chosen to maximize the amount of flexible mission area in the stern. Also, the side hulls positioned at the stern are expected to reduce overall ship resistance when the ship is traveling at speeds greater than 25 kt.<sup>10</sup> The depth of the side hulls was chosen to ensure that the draft of the side hulls was sufficient in all conditions of loading and roll.<sup>11</sup>

**Table 15. Ship Geometry**

Length	148 m
Side Hull Length	22.2 m
Main Hull Beam	11.7 m
Side Hull Beam	2.5 m
Overall Beam	21.8 m
Main and Side hull Separation	2.55 m
Depth at Station 10	10.09 m
Maximum Side Hull Depth	7.75 m
Main Hull Cp	0.66
Main Hull Cx	0.69
LCB/LBP	0.578
KG	5.81 m
GMT/B <sub>overall</sub>	0.1147
Main Hull L/B	12.65
Main Hull Displacement	3505 lt
Side Hull Displacement	27 lt each
Total Displacement	3559 lt

#### 4.1.2 Arrangements

##### 4.1.2.1 General Arrangements

The arrangements were performed using the requirements for space and volume generated using ASSET. One exception to this is the volume requirement for fuel. This requirement was obtained from the Displacement Hull Design Tool. ASSET could not

accurately predict the fuel requirements because ASSET did not have the resistance and powering information for the trimaran hull type.

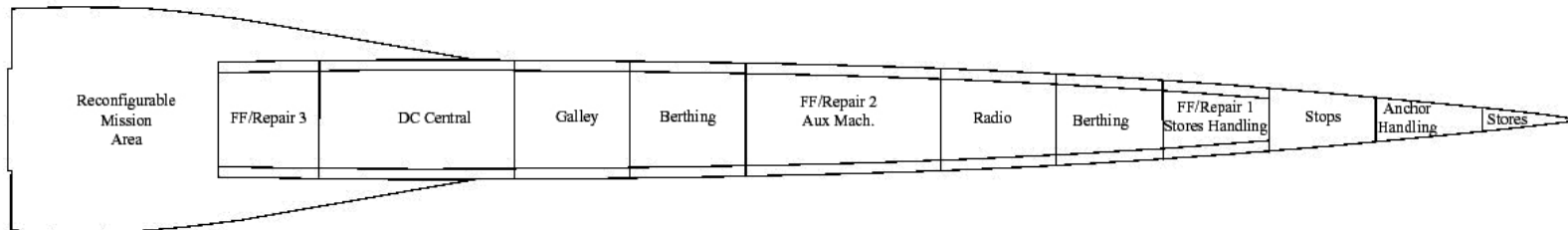
The general arrangements are shown in Figure 5 through Figure 9. The arrangements requirements and allocation are included as Appendix C.

							Bridge										
		Hangar			Aviation	IC	Radar	Radar	Radar	Stacks	CO						
					Aviation	JO's	WR	DH's	Offices	Stacks	RAS						
Mission Area	Mission Area	FF/R	DC Central, Shops		Galley	Berthing		FF/R, Aux Mach.		Radio	Berthing	FF/R, Stores	Shops	Anchor Hand.	Deck Stores		
Water Jets	ATM CTRL.	DG/GT CTRL	MMR2		AMR2	CIC, CPO		MMR1		AMR1	DG/GT CTRL	Stores	Stores	Anchor Chair			
	Fuel	Fuel				Water, Ballast					Aux Mach.	Aux Mach.	Aux Mach.	Anchor Chair			

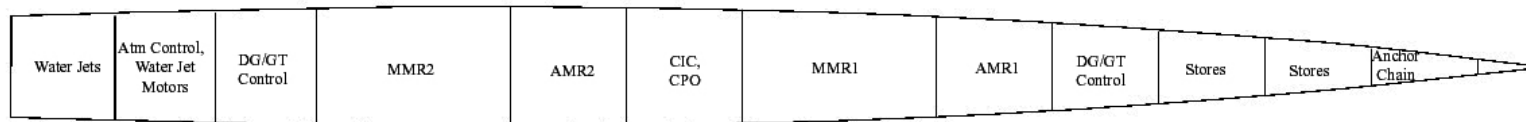
**Figure 5. Profile of Arrangements**



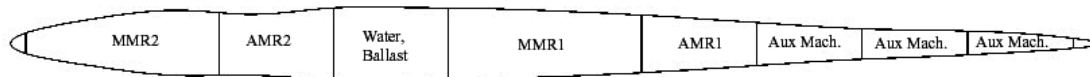
**Figure 6. Main Deck**



**Figure 7. First Deck Arrangements**



**Figure 8. Second Deck Arrangements**



**Figure 9. Third Deck Arrangements**

The arrangements made efficient use of space while meeting the needs imposed by survivability, habitability, and stability. The first deck below the main deck is the Damage Control Deck. This deck is continuous and has all repair lockers and firefighting stations as well as Damage Control Central. Large passageways on either side of the ship ensure ease access fore and aft. Below the first deck, longitudinal access between compartments is prevented. Vertical access to the spaces is by means of ladders placed throughout the ship. Most compartments have ladders at their centerline, both fore and aft.

To maintain effectiveness after a hit, the Combat Information Center is located low in the ship and the crew berthing is separated. Officers are berthed near the bridge, the Combat Information Center, and Damage Control Central for ready access. Messing and berthing facilities are located near each other to promote quality of life.

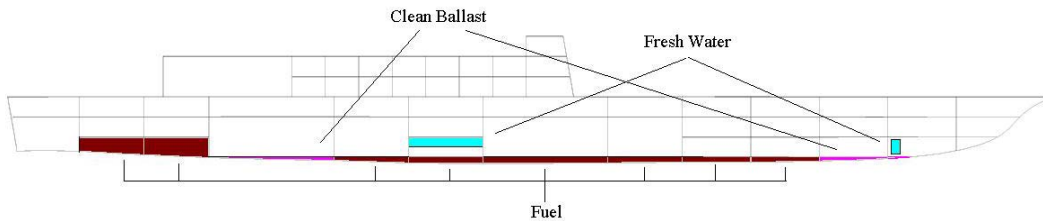
The flexible mission area was located at the stern of the ship for a variety of reasons. This area is near the helicopter landing pad to facilitate movement and installation of modules. The stern of the ship is the preferred location for launching and recovering small boats and unmanned vehicles. The large arrangeable space provided by the cross-deck structure to the side hulls provides a flexible area for a variety of uses.

#### 4.1.2.2 Tank Layout

Table 16 shows the required and allocated tankages. Some cases have excess volume assigned because that space on the ship was too small to be useful arrangeable area. Figure 10 shows the tankage arrangements. Tankage layout was performed using a spreadsheet and verified in stability analyses.

**Table 16. Required and Allocated Tankages**

Type	Reqd	Allocated
Aviation Fuel	59.9	59.9
OOV Fuel	24	24
Endurance Fuel	356.6	553.6
Clean Ballast	50	75
Freshwater	17.3	34.3



**Figure 10. Tankage Arrangements**

#### 4.1.2.3 Area and Volume Balance Summary

Table 17 contains the area and volume balance summary. Over 99% of area and volume have been allocated. This summary does not include the additional area provided by the cross structure to the side hulls. That additional area is assigned to the modular

mission space. Additional volume provided in the side hulls is filled with syntactic foam for stability.

The allocated area represents 100% of the required area.

**Table 17. Weight and Volume Balance Summary.**

Total Area	3455.2 m <sup>2</sup>
Passageways	223.8 m <sup>2</sup>
Ladders	214.8 m <sup>2</sup>
Allocated Area	3438.9 m <sup>2</sup>
Difference	0.5 %
Total Volume	1044.0 m <sup>3</sup>
Allocated Volume	1038.4 m <sup>3</sup>
Difference	0.1 %

#### 4.1.3 Combat System/C4ISR

The combat systems of the Focused Mission High Speed Combatant consist of the Core Mission Systems necessary for the basic defense of the ship and the Modular Mission Systems necessary to perform the assigned missions. Table 18 lists the Core Mission Systems and Table 19 lists the Modular Mission Systems. The configuration of the Modular Mission Systems will depend upon the nature of the assigned mission.

**Table 18. Core Mission Systems.**

Cooperative Engagement Capability (CEC)
AIEWS Phase I - AN/SLQ-32(V)3
SPY-1K Phased Array Radar
AN/SPQ-9( ) Radar
Surface Search Radar - AN/SPS-64
MK 99 Fire Control System
2x MK 16 CIWS Gun Mount
Underwater Fire Control System
MK XII AIMS IFF
RAM LAUNCHER - 8 CELL RALS
Nulka
SRBOC
Hangar and Facilities for SH-60 Helicopter



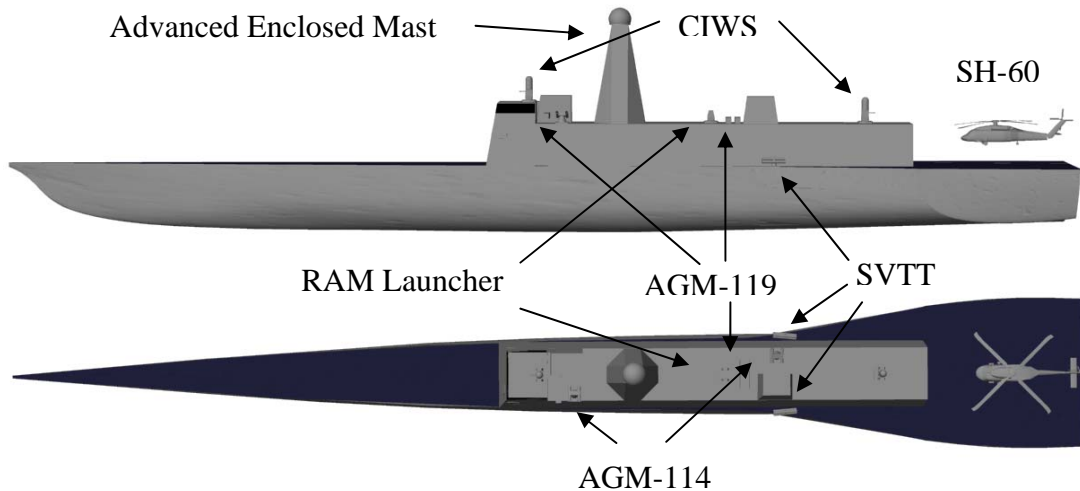
**Table 19. Modular Mission Systems.**

2x MK 19 40mm Gun
MFTA Multi Function Towed Array
2x AGM-114M Hellfire II Surf-to-Surf Missile Sys Crossbow Launcher w/ 2 missiles
3x AGM-119B Penguin Surf-to-Surf Missile Sys (Mk 2 Mod 7N) Launcher w/ 6 missiles
2x-Enclosed Mk 32 MOD 9 Dual Tube SVTTs
Spartan USV
Long Term Mine Reconnaissance System (LMRS)
Remote Minehunting System (RMS)
Firescout UAV

4.1.3.1 Combat Systems Arrangements

Figure 11 shows the combat systems arrangements. The combat systems are located to provide maximum coverage for each system. Surface vessel torpedo tubes are mounted next to the superstructure for ease of reloading and maintenance. All other weapons systems are placed above the superstructure to avoid spray on the fore deck and to maximize the flexible mission area on the aft portion of the main deck. The high location of the weapons systems also allows them to provide coverage at slightly longer ranges. The weapons are dispersed throughout the top of the superstructure to reduce loss in the event of battle damage.

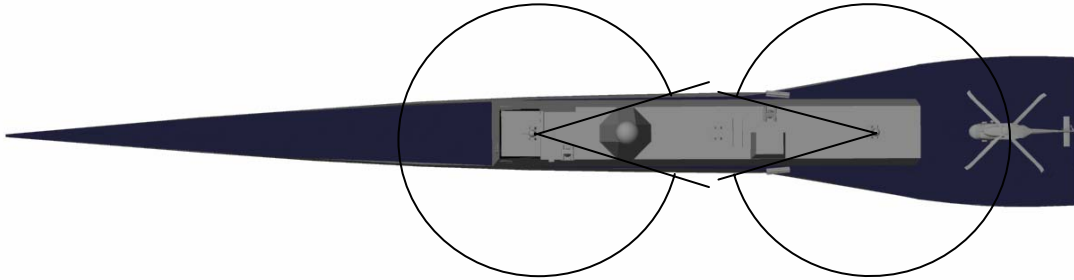
The helicopter hangar will accommodate 2 SH-60 helicopters and is located aft of the superstructure in the most stable area of the ship.



**Figure 11. Combat Systems Arrangements**

#### 4.1.3.2 Arcs of Fire

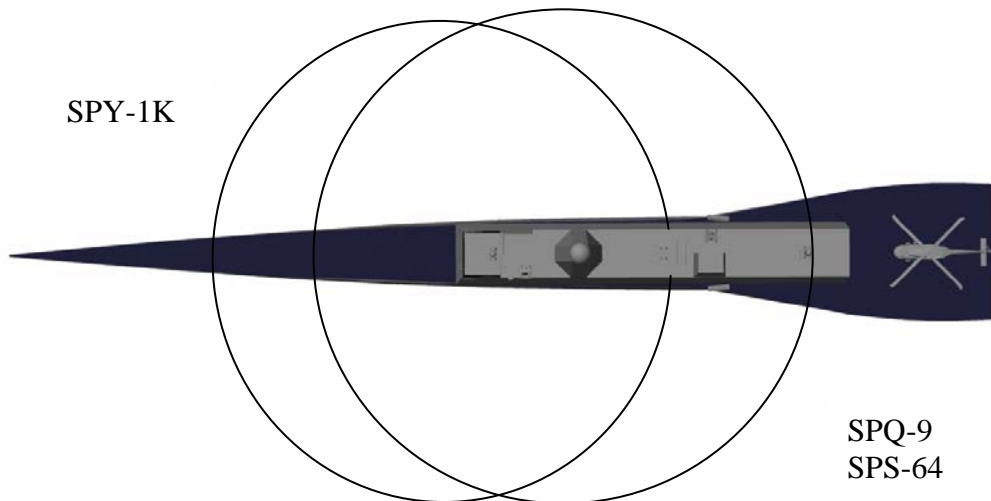
All weapons systems have 360° coverage. Torpedoes are fired in a forward direction and maneuver as directed providing coverage in all directions. Missiles also maneuver to hit the target. The only systems which do not have maneuver after launch capability are the MK 16 CIWS. The arcs of fire for this system are presented in Figure 12.



**Figure 12. CIWS Arcs of Fire.**

#### 4.1.3.3 Sensor Coverage

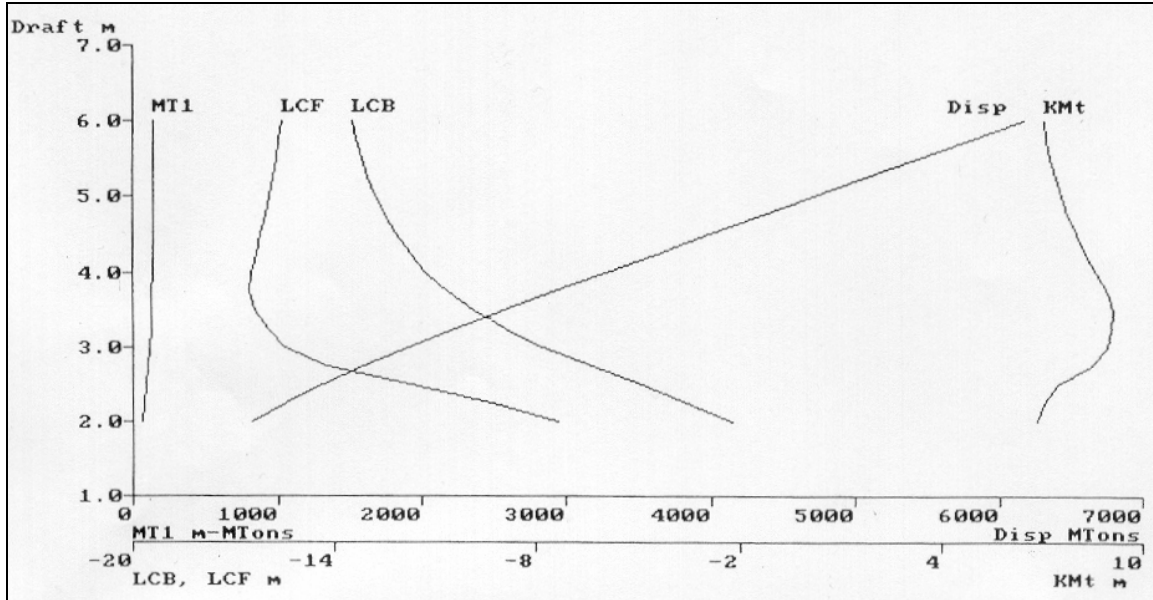
Sensor coverage is shown in Figure 13. The SPY-1K radar mounted on the front and sides of the deckhouse does not have complete coverage. There is a small arc in the stern that is not covered by the SPY-1K. This deficiency is compensated for by the SPQ-9 radar mounted on the Advanced Enclosed Mast assembly. The SPQ-9 has 360° coverage. The AN\SPS-64 Surface Search Radar is mounted in the Advanced Enclosed Mast assembly and has 360° coverage.



**Figure 13. Sensor Arcs of Coverage**

#### 4.1.4 Trimaran Hydrostatics

POSSE (Program of Ship Salvage Engineering) was used to perform the hydrostatic analysis of the trimaran. The hydrostatic tables and the tankage allocation are presented in Appendix D. Figure 14 shows the curves of form of the trimaran.



**Figure 14: Curves of Form**

##### 4.1.4.1 Intact Stability

A ship's stability may vary substantially during the course of the voyage. It is very important to determine which loading condition is the least favorable and will therefore govern required stability. Full load and minimum load condition stabilities were examined by calculating the effects of high wind on the beam of the ship, crew crowding to one side of the ship, and a high speed turn.

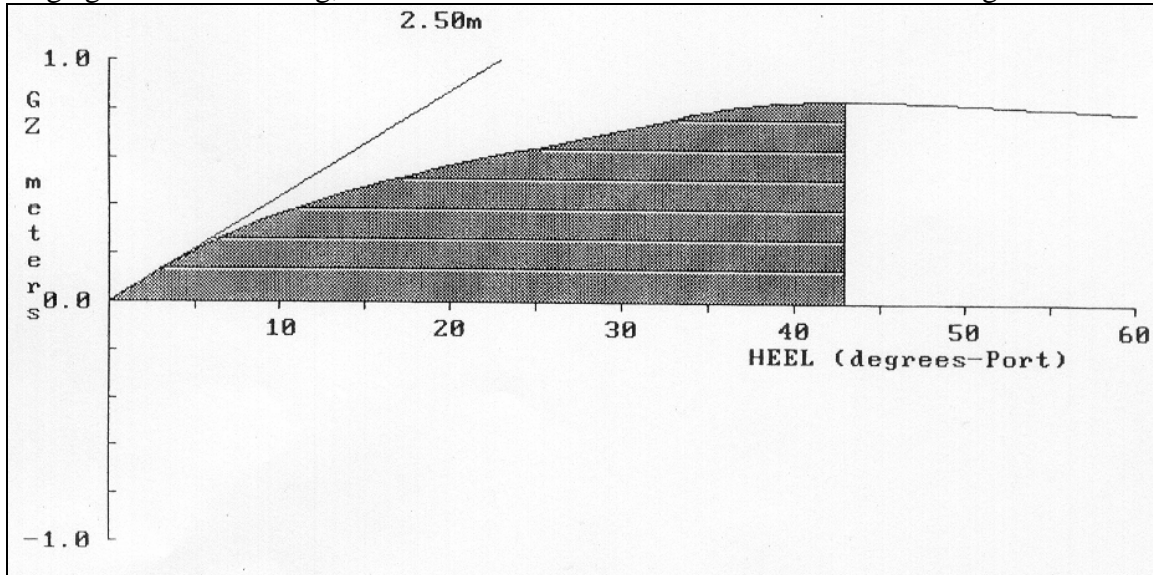
The requirements for intact and damaged stability of a ship can be found in a variety of documents. The principle document for stability of United States Navy Ships is Design Data Sheet 079-1, Stability and Buoyancy of U.S. Naval Surface Ships. Recently, additional documents have been issued by classification societies to address the need for clear requirements for naval ships developed by the international community. Some of these documents include the Guide for Building and Classing High Speed Naval Craft 2002 from the American Bureau of Shipping<sup>12</sup> and the International Code for High-Speed Craft, 2000 from the International Maritime Organization<sup>13</sup>. DDS 079-1 has been used exclusively for this study.

##### 4.1.4.1.1 Full Load Condition

For the full load condition all the assigned fuel and fresh water tanks are 98% full. The clean water ballast tanks are empty in order to compensate for the fuel burned. The analysis showed that in the full load condition the vessel has zero trim and list. The center of gravity is 5.81 meters above the keel, and the longitudinal center of gravity is 62.35 meters forward from the aft perpendicular. The transverse metacentric height

(GM<sub>T</sub>) is 2.5 meters, which was carefully selected to optimize the seakeeping performance of the vessel. The detailed results of the full load condition stability analysis are presented in Appendix E.

Figure 15 shows the righting arm of the full load condition. Positive GZ extends for a range greater than 60 deg, and has a maximum value of 0.84 meters at 43 deg.



**Figure 15: Righting Arm at Full Load Condition**

### Beam Wind

Every ship that moves with amphibious and strike forces must be able to withstand tropical cyclones. Therefore the maximum design wind velocity is assumed to be 100 knots. A general formula that is used to describe the unit pressure on a ship due to beam winds is:

$$P = C \cdot \rho \cdot \frac{V^2}{2 \cdot g}$$

Where

C=dimensionless coefficient for ship type

ρ=Air density

V=wind velocity

However, the most widely used expression for pressure in English units is:

$P=0.004 \cdot V^2$ ,<sup>14</sup> and the expression of the heeling arm due to wind is:

$$HA = \frac{0.004 \cdot V^2 \cdot A \cdot L \cdot \cos^2 \phi}{7466.57 \cdot \Delta}$$

Where

A= projected area, m<sup>2</sup>

L= lever arm, m

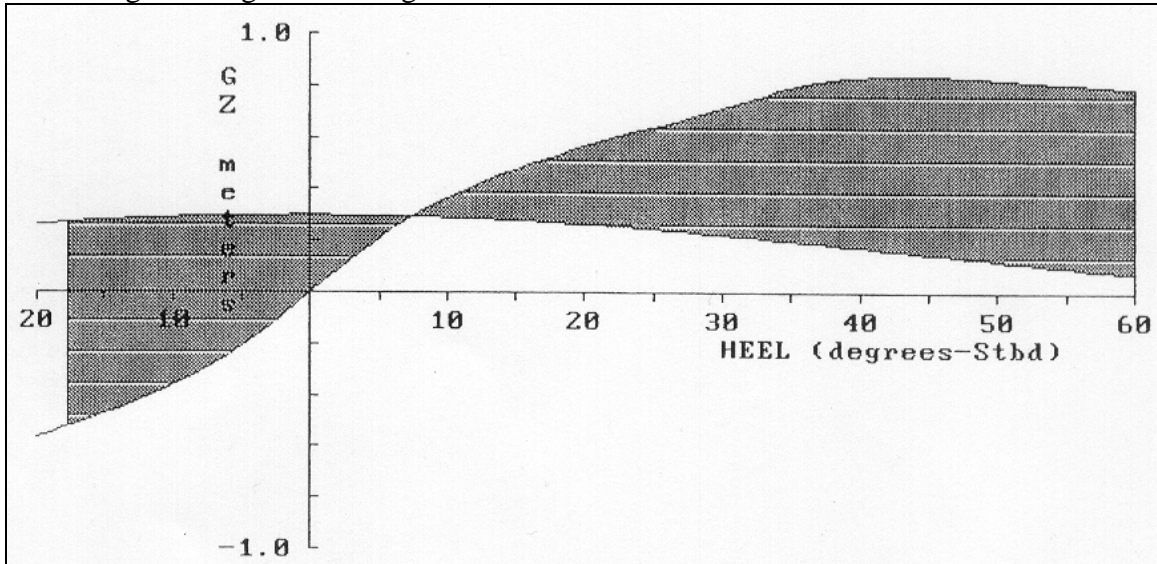
V= wind velocity, knots

$\varphi$ = angle of inclination  
 $\Delta$ = displacement, tonnes

The criteria for adequate stability when encountering adverse wind are

- 1) The heeling arm at the intersection of the righting arm and the heeling arm curves is not greater than six-tenths of the maximum righting arm.
- 2) The area between the righting arm and the heeling arm curves on the right side of their intersection point is not less than the area between the righting arm and the heeling arm curves on the left side of their intersection point until 25 deg. windward from the intersection point.

POSSE was used to examine the intact stability of the Focused Mission High Speed Combatant with a beam wind of 100 knots. The resulting righting arm curve and the heeling arm curve are shown in the Figure 16. Detailed results are included as Appendix E. These results show that the ship meets the requirements for beam wind loading and has a resulting heel angle of 7.4 degrees.



**Figure 16: Full Load Righting Arm for Beam Wind and Rolling**

### High Speed Turn

The second condition examined for intact stability is the high-speed turn. The centrifugal force acting on a ship during a turn may be expressed by the formula:

$$F = \frac{\Delta \cdot V^2}{g \cdot R}$$

Where,

- $\Delta$ = displacement, tonnes
- $V$ = the linear velocity of the ship in the turn
- $g$ = the acceleration of gravity
- $R$ = the radius of turning circle

The lever arm in conjunction with this force to obtain the heeling moment is the vertical distance between the ships center of gravity and the center of lateral resistance of the underwater body. The length of this lever arm will vary as the cosine of the angle of

inclination. The center of lateral resistance is usually taken vertically at the half draft. If the centrifugal force is multiplied by the lever arm and divided by the ships displacement, an expression for the heeling arm is obtained.

$$HA = \frac{V^2 \cdot K \cdot \cos \varphi}{g \cdot R}$$

Where

K= distance between ship's center of gravity and center of lateral resistance

$\varphi$ = angle of inclination

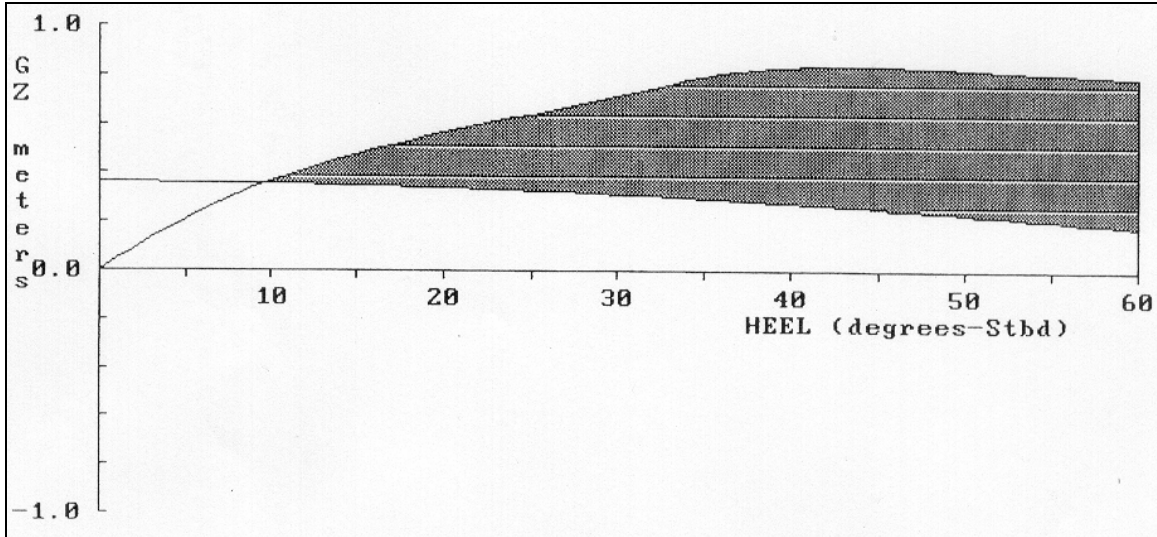
The criteria for adequate stability for high-speed turn are based on a comparison of the righting arm and heeling arm curves. Stability is considered satisfactory if:

- 1) The angle of heel does not exceed 15 deg.
- 2) The heeling arm at the intersection of the righting arm and the heeling arm curves is not more than six tenths of the maximum righting arm.
- 3) The reserve of dynamic stability (Area between the righting arm and the heeling arm curves on the right side of their intersection point) is not less than four tenths of the total area under the righting arm curve.

Angles of heel in excess of 15 deg interfere with operations aboard the ship and adversely affect the safety and comfort of the personnel. In addition, the requirements that the heeling arm be not more than six-tenths of the maximum righting arm and that the reserve of dynamic stability be not less than four-tenths of the total area under the righting arm curve are intended to provide a margin against capsizing. These margins allow for possible inaccuracies resulting in the heeling arm calculations and seas.

The intact stability of the trimaran in a high-speed turn at 40 knots with a turning circle radius equal to 444 m was calculated using POSSE. The resulting righting arm curve and the heeling arm curve are shown in the following Figure 17. This figure shows that the heeling angle is 9.6 deg, less than the 15 deg limit. The maximum heeling arm is less than one-tenth of the maximum righting arm and the reserve of dynamic stability is not less than four-tenths of the total area under the righting arm curve.

The turning circle radius was selected in order to meet the criteria. The selected turning circle is three times the length between perpendiculars of the ship, but generally the turning circle radius of a ship is approximately equal to two times the length of the ship. The actual turning radius is determined through testing. As an important safety consideration at high speeds, the turning radius of the ship must be limited to 444 m to ensure adequate stability. This limitation can be imposed by some sort of rudder motion limit. The recommended device is a software limit that is automatically imposed at high speeds.



**Figure 17: Full Load Condition Righting Arm Curve for High Speed Turn**

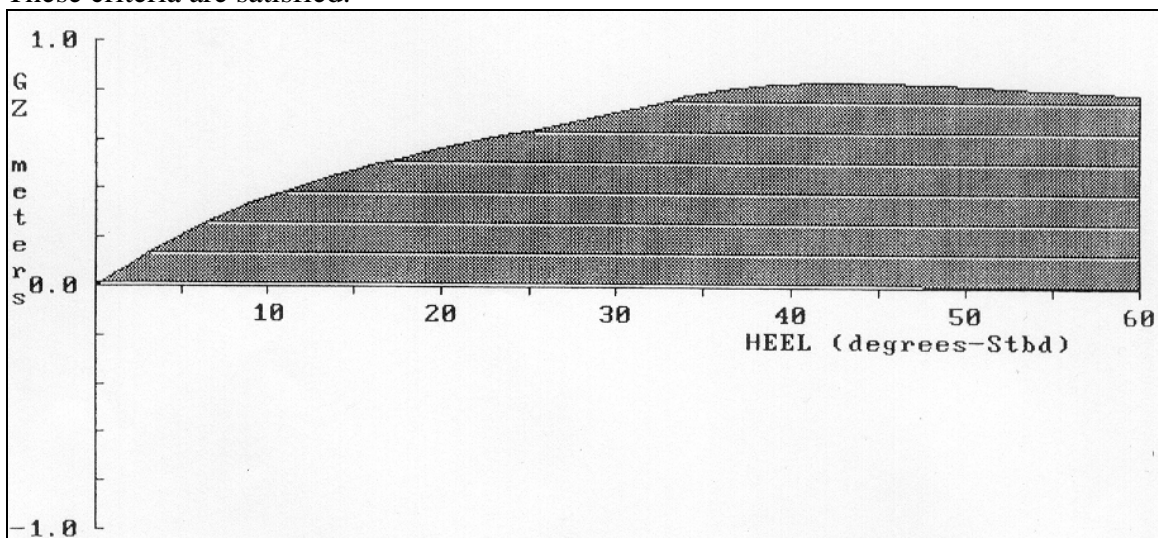
### Personnel Crowding

The effect of personnel crowding to one side condition was examined using POSSE. Figure 18 presents the curve of the righting and heeling arms. The heeling arm is not visible in Figure 18 because it is so small. The heel due to personnel crowding to one side is negligible.

The criteria for adequate stability are satisfied if

- 1) The maximum angle of heel does not exceed 15 degrees.
- 2) The heeling arm at the intersection of the righting arm and heeling arm curves is not more than six-tenths of the maximum righting arm, and
- 3) The reserve of dynamic stability is not less than four-tenths of the total area under the righting arm curve.

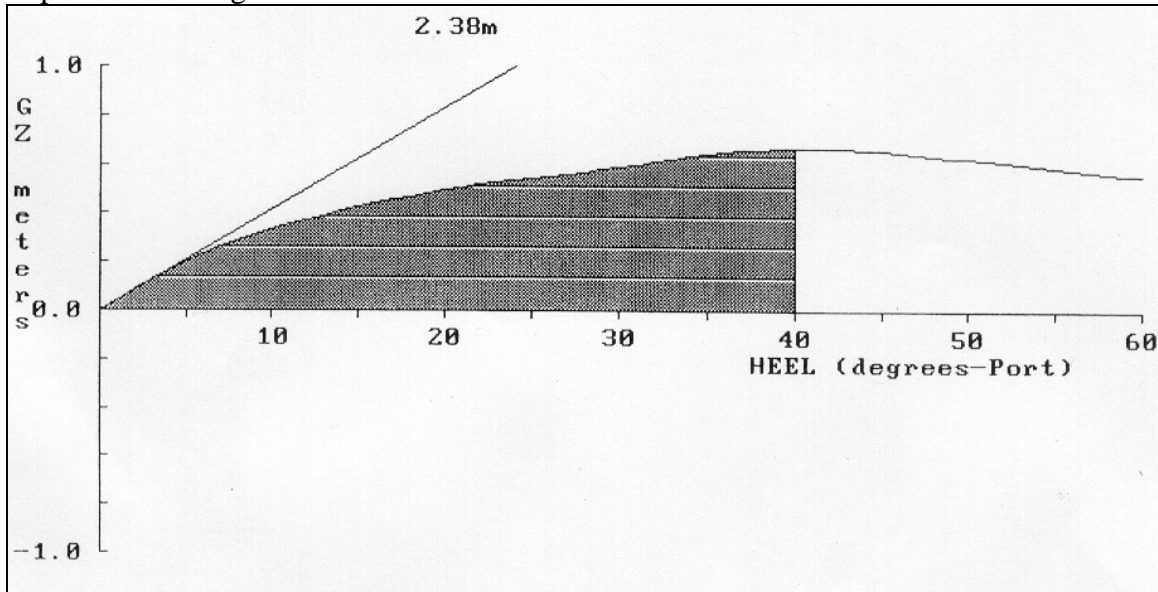
These criteria are satisfied.



**Figure 18: Full Load Righting Arm for Personnel Crowding to One Side**

#### 4.1.4.1.2 Minimum Load Condition

For the minimum load condition only one third of the fuel and one third of the fresh water is on board. The ballast tanks are filled as necessary to maintain zero degree trim and list. The  $GM_T$  of the minimum load condition is 2.38 meters. The weights of the liquids and their centers of weight are presented in Appendix F. Righting arm is positive for a range greater than 60 deg and the maximum GZ is 0.67 meters and occurs at 41 deg as presented in Figure 19.



**Figure 19: Righting Arm of Minimum Load Condition**

The analyses of the 100 knot beam wind, high speed turn, and the personnel crowding conditions, presented in Appendix F, show that the vessel meets all the intact stability criteria for the minimum load condition.

#### 4.1.4.2 Damaged Stability

The damaged stability analysis was also based on the requirements of the US Navy DDS- 079-1. One requirement is that ships over 300 ft in length shall withstand a shell opening of 15% of the ship's length of waterline, at any point fore and aft. DDS 079-1 takes into account only the possibility of a hit of a torpedo or a missile, but ignores the possibility of grounding or underwater explosion (mines). Since the ship is especially designed for the littorals, damage due to underwater explosions caused by mines is one of the more likely possibilities. The damage caused by such an explosion could extend to one or both of the side hulls in addition to the main hull. Therefore, the cases where both the side hull(s) and the main hull could be damaged were examined.

The two worst cases were:

- a) Damage of 15% of LBP in the aft body of the ship and one of the side hulls
- b) Damage of 15% of LBP in the aft body of the ship and both of the side hulls.

It is important to mention that this analysis lead to a trade off in the selection of the length of the side hulls. Two options were considered: 22 m and 44 m side hulls. The 44 m side hulls design met the damaged stability criteria with proper subdivision. On the



other hand, 44m side hulls added extra weight to our ship and reduced the maximum speed from 41.9 kt to 39 kt. The 22 m side hull design passed the stability criteria if foam was added to the side hulls. Table 20 shows the key points of comparison between the designs.

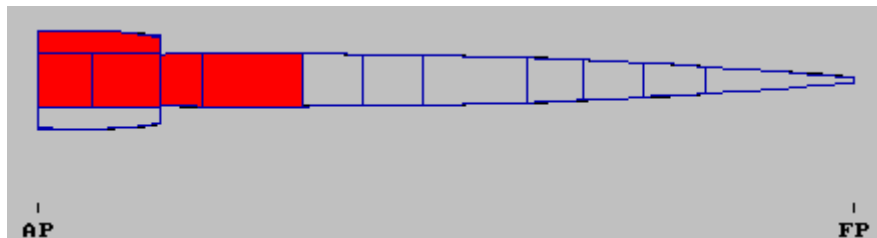
The foam is syntactic foam and is currently used for filling voids in Navy submarines to protect from moisture and provide extra buoyancy. The foam is applied either by pouring or by spraying and is easy to remove if needed. The removal is done in a shipyard; the foam is simply chipped off. The syntactic foam fills the 22 m side hulls up to the first deck, allowing zero permeability for water to enter in the damaged case. In this way, only 40 tons are added and both side hulls give extra buoyancy to the vessel.

**Table 20. Comparison of 22 m and 44 m Side Hull Designs**

	22m Side hulls	44 m Side hulls
Speed	42 kt	39 kt
Displacement	3,559 mt	3,950 mt
Seakeeping	Increased motion amplitudes	Increased accelerations
Intact Stability	Large heel angle at high speed turn	Reduced heel angle at high speed turn
Damaged Stability	Requires foam	Requires subdivision
Arrangeable Area		Increased arrangeable area

Case 1: Damage of 15% of LBP in the aft body of the ship and one of the side hulls

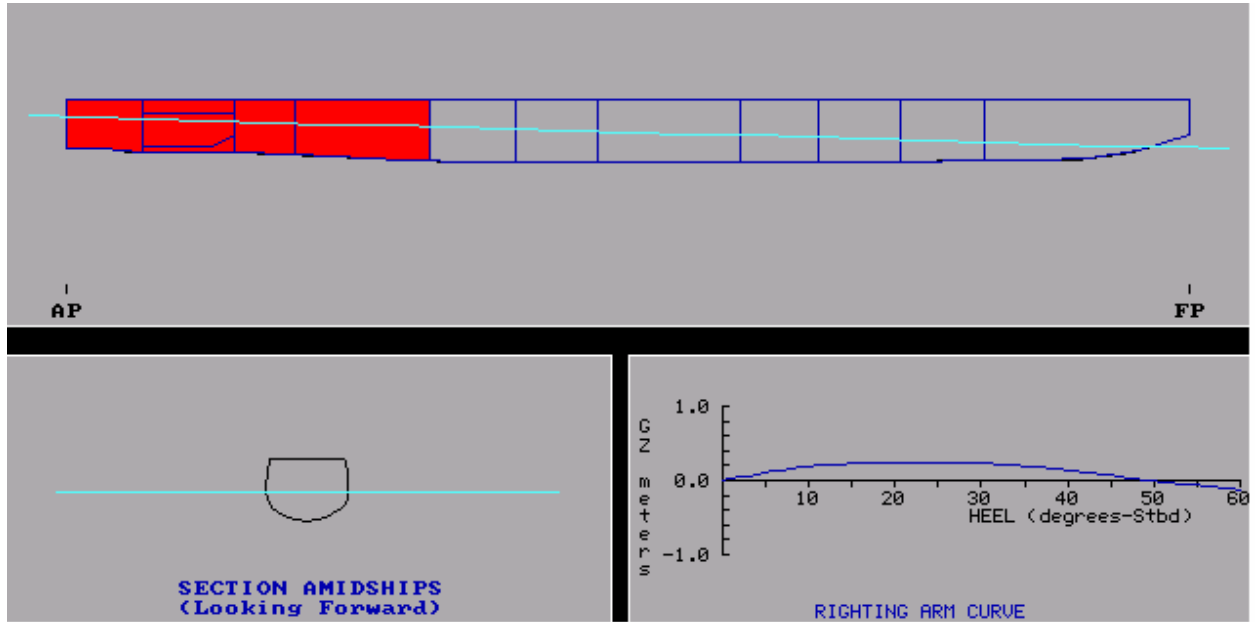
In order to withstand hull damage 15% of the length of the waterline, the ship must be able to withstand flooding in four consecutive compartments (extreme aft compartments). Side hull flooding is not included since syntactic foam was used. Figure 20 shows the top view of this case. Figure 21 shows the plot of the righting arm curve for this case.



**Figure 20. Top View of Damaged Condition with Main Hull and One Side Hull Damaged**

Table 21 shows the results from POSSE for the evaluation of this damage case. It is important to note that even though the side hull is damaged it will not get any water since it has zero permeability. That is why the ship has only a zero degree heel (only center compartments are damaged). DDS-079-1 requires the ship to have an initial angle of heel

less than 15 degrees and to have adequate dynamic stability to absorb the energy of moderately rough seas with beam winds. The Focused Mission High Speed Combatant meets both criteria.



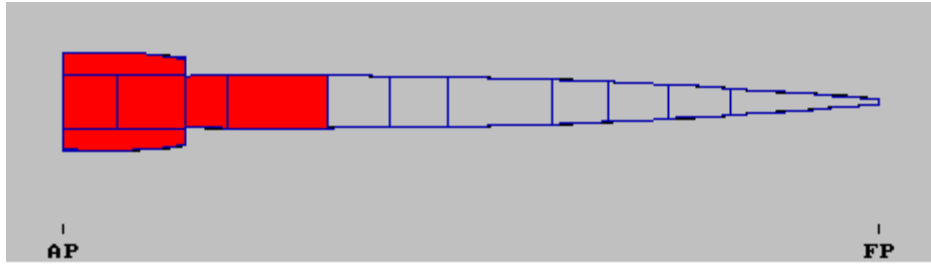
**Figure 21. Trim, List, and Righting Arm for Damaged Condition with Main Hull and One Side Hull Damaged**

**Table 21. Stability Characteristics for Damaged Condition with Main Hull and One Side Hull Damaged**

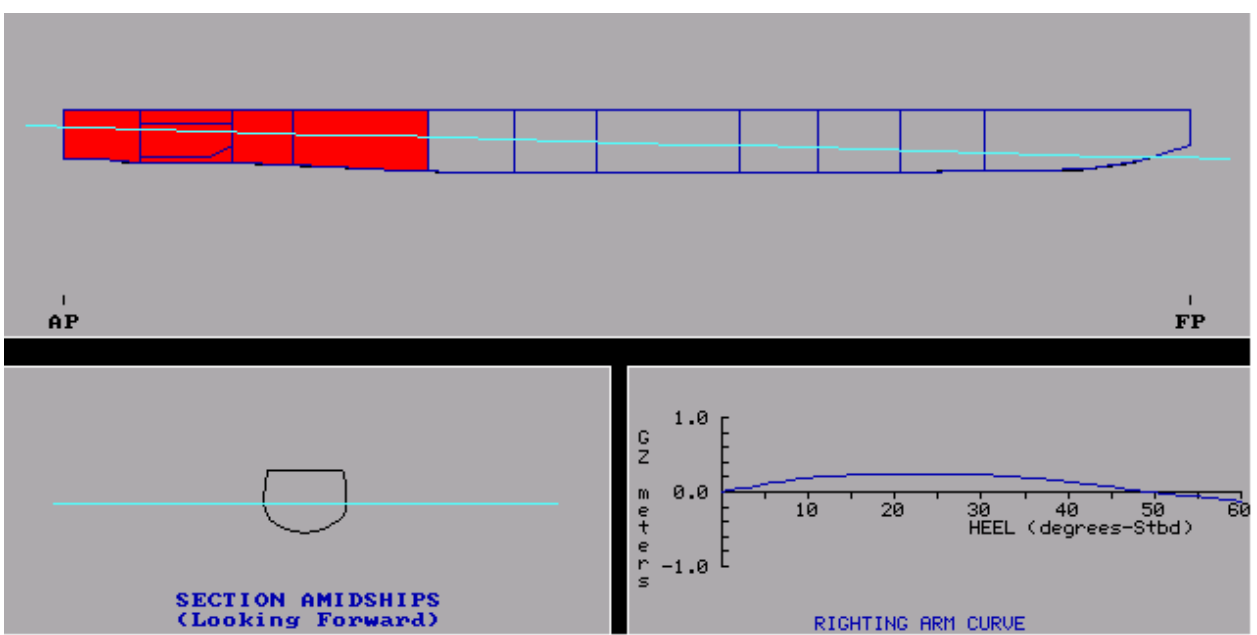
Static Heel Angle	0.0 degrees
Angle at Max GZ	25.6 degrees
Max GZ	0.24 m
Range of Positive GZ	49.9 degrees
$GM_T$	1.7 m

Case 2: Damage of 15% of LBP in the aft body of the ship and both of the side hulls

In this case, in order to withstand hull damage 15% of the length of the waterline, the ship must be able to withstand flooding in four consecutive compartments (extreme aft compartments) and in both side hulls. Figure 22 shows the top view of the graphical representation of this damage. Figure 23 shows the plot of the righting arm curve for this case. The righting arm is the same with the damaged condition with the main hull and one side hull damaged. This is expected due to the zero permeability of the side hulls. The values for the stability evaluation of this case are the same as previously shown in Table 21.



**Figure 22. Top View of Damaged Condition with Main Hull and Both Side Hulls Damaged**



**Figure 23. Trim, List, and Righting Arm for Damaged Condition with Main Hull and One Side Hull Damaged**

The ship is able to meet all damaged stability requirements. The detailed results of the calculations are included as Appendix G.

4.1.5 Trimaran Hydrodynamics

The resistance and the seakeeping characteristics of a vessel are affected by the hull form design choices. Usually a tradeoff exists between optimization of a hull form for resistance and seakeeping. Therefore, analyses of resistance and seakeeping are performed together.

#### 4.1.5.1 Hydrodynamic Comparison of Hull Forms

The trimaran configuration shows considerable improvement in terms of resistance at high speeds compared to equivalent monohulls. At low speeds, where frictional resistance dominates, the trimaran configuration is disadvantageous due to the increased wetted surface area. At higher speeds, where the wave-making resistance dominates, trimarans have reduced resistance compared to the equivalent monohull, mainly due to the slender shape. The Length to Beam ratio of a trimaran is between 12 and 14 compared to 7.5 or less to 10 for a typical monohull. Hence the reduction in residuary resistance of a trimaran at higher speed outweighs the increase of frictional resistance.

A significant advantage of trimaran ships is the seakeeping behavior. Trimarans are expected to have better seakeeping characteristics than monohulls and catamarans. The center hull of a trimaran is longer than a conventional monohull or a catamaran and is expected to have lower pitch and heave motions.

Compared to catamarans, which have similar resistance advantages, trimarans have better roll characteristics. The high transverse inertia of catamarans leads to a reduction in roll amplitude but increases roll accelerations.<sup>15</sup> The transverse inertia of a trimaran is smaller and can be easily adjusted by varying the dimensions and the separation of the side hulls. Hence, the roll period can be tuned to the desired value.

In addition, trimarans do not face the unpleasant coupling of motions faced by catamarans. The natural periods of roll and pitch of catamarans are very close leading to coupling between roll and pitch. Furthermore, the cross structure of some trimarans is located at the aft part of the vessel and faces less slamming than the cross structures of catamarans.

Compared to monohulls, trimarans have better operability in waves. Trimarans face less speed reduction due to bow slamming, deck wetness, bridge deck acceleration, and flight deck acceleration limits.<sup>16</sup> These advantages can only be realized by a careful design of the side hull configuration, though.

#### 4.1.5.2 Hydrodynamic Effect of Side Hull Configuration

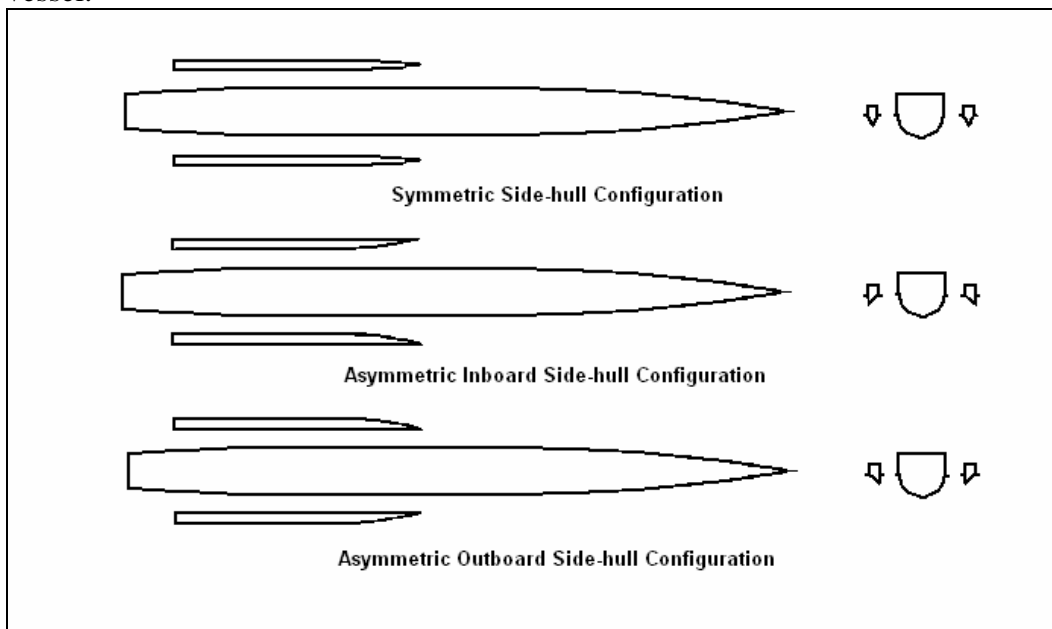
The side hull shape, separation, displacement, and longitudinal location can be varied to achieve the required resistance and seakeeping characteristics. The displacement of the side hulls affects the frictional resistance of the vessel and the stability, while the position determines the magnitude of the interaction effects between the side hulls and main hull, the stability, and the susceptibility to parametric roll. In addition the variety of possible side hull configurations allows the designer to optimize the seakeeping performance of a trimaran.

There are three side hull designs that can be used in a trimaran. These include symmetric, asymmetric inboard, and asymmetric outboard and are shown in Figure 24<sup>17</sup>. Symmetric side hulls were used in the design, mainly due to the inability of the available design tools to analyze the resistance and seakeeping characteristics of the other configurations. R.V. Triton, which is the trimaran technology demonstrator, is using a modified asymmetric outboard side hull configuration.

The side hull symmetry greatly affects the magnitude of the interference effects between main hull and side hulls. The asymmetric inboard configuration tends to show the greatest variation in the magnitude of the interaction effects and produces extremely high or extremely low interference at some speeds and positions of side hulls. The

symmetric side hull configuration also shows variations but not as pronounced as the asymmetric inboard configuration. Finally, the asymmetric outboard configuration demonstrates the smallest variations in interference.<sup>18</sup>

There is no single side hull position that consistently out-performs the others. In general, the lowest interference at low speeds occurs with the side hulls forward and close to the main hull. At moderately high speeds the lowest interference occurs when the side hulls are placed aft and further outboard. As speed increases further, the optimum location is aft and close to the main hull. Since a maximum speed greater than 40 knots was required, the ship runs at relatively high Froude numbers. Therefore, the side hulls were placed aft and as close to the main hull as possible while still providing good seakeeping and stability characteristics. Transverse separation of side hulls also affects the transverse moment of inertia, and hence the roll period and the motions of the vessel.



**Figure 24: Trimaran Side Hull Configurations (17)**

The displacement of the side hulls affects the transverse moment of inertia and, as a result, the seakeeping performance of the vessel. An increase in the side hull displacement leads to an increase in the wetted surface and increases the frictional resistance.<sup>19</sup> In order to reduce the frictional resistance of the vessel, the displacement of the side hulls was kept as low as possible, taking into account the seakeeping and stability performance.

#### 4.1.5.3 Seakeeping Analysis

Roll motions are the most difficult motions of a trimaran to predict. Waves that have an encounter frequency near natural frequency of the ship in roll can cause a ship to roll severely. The behavior of the trimaran in roll motions is mostly affected by the presence and location of the side hulls.

Gillmer and Johnson give the undamped roll equation as<sup>20</sup>:

$$I_{44\_trimaran} (1 + X_A) \phi'' + \Delta GM_T \phi = 0$$

Where

$X_A$  is the added mass coefficient of the roll motion,

$I_{44\_trimaran}$  is the moment of inertia in roll

$\Phi''$  is the angular acceleration, and

$\Delta GM_T \Phi$  is the righting arm converted in radians

The moment of inertia can be calculated by multiplying the total mass of the ship by the roll radius of gyration:

$$I_{44\_Trimaran} = M \cdot k_{44\_Trimaran}^2$$

The calculation of roll radius of gyration for the trimaran is presented in Appendix H.

The moment of inertia for the trimaran can be derived by adding the moment of inertia for the main hull in roll and the added mass for the two side hulls in heave multiplied by the separation of the side hull and the main hull. This is shown by the following equation:

$$a_{44\_trimaran} = a_{44\_mainhull} + 2 \cdot C^2 \cdot a_{33\_sidehull}$$

where C is the separation between the side hull and the main hull.

Finally, the roll period of the trimaran can be calculated using:

$$T_{roll} = 2\pi \sqrt{\frac{I_{44\_trimaran} + a_{44\_trimaran}}{\Delta \cdot GM_T \cdot 9.81 \frac{m}{s^2}}}$$

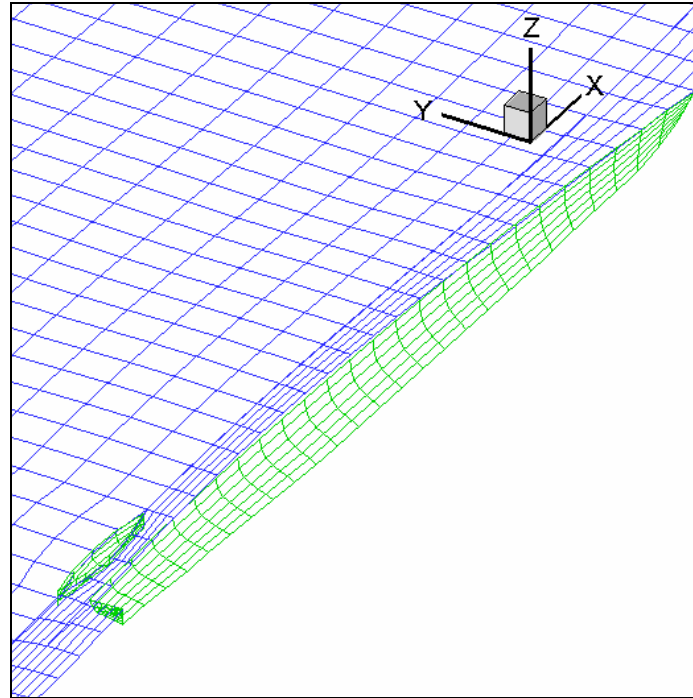
These two equations show that the designer has the flexibility to tune the roll period of the trimaran by varying parameters. The roll period can be increased by increasing the separation of the side hulls, by increasing the displacement of the side hulls (both increase  $a_{33\_sidehull}$ ), or by reducing  $GM_T$ .

The value of  $GM_T$  is the factor that most influences roll motions and should be selected very carefully. Although the values of roll angles are not very sensitive to the variation of  $GM_T$ , the values of roll accelerations are. Values of  $GM_T$  close to 2 meters have lower roll accelerations than with  $GM_T$  close to 4 meters<sup>21</sup>. However, the limiting factor for the reduction of  $GM_T$  is intact and damaged stability, which were very carefully examined during the process of selecting the final value of  $GM_T$ . The selected value for  $GM_T$  is 2.5 meters and the roll period is 7.3 seconds. Detailed calculations are included as Appendix I.

During the preliminary design of monohulls strip theory is a good method of examining the response of a ship in a seaway. The limitation of strip theory is that it is not valid at low frequencies and high speeds and therefore might fail to give good results for fast ships or following and quartering seas.<sup>22</sup> Strip theory also assumes small, linear motions, and neglects the above water hull form. The main limitation of strip theory for the use in trimaran design is the fact that it does not account for hull interaction effects.

To overcome the limitations of strip theory, a three dimensional panel method code was used for the seakeeping analysis of the trimaran design. In a three dimensional panel method all body surfaces are discretized into panels. The free surface surrounding the ship is also discretized into panels, and the standard free surface boundary condition is imposed upon them. The computational domain is composed of groups of panels representing the ship and the free surface. Potential-based panel methods ignore viscous effects, but, dimensional analysis can show that these effects are a negligible part of the wave body interaction problem.<sup>23</sup> The seakeeping code used for this study was the Ship

Wave Analysis code (SWAN), and the three dimensional panel distribution is presented in Figure 25.



**Figure 25: Three Dimensional Panel Distribution**

According to the preliminary design requirements, the threshold requirement for launch and recovery of aircraft is sea state 4 at best heading, and the goal is sea state 5 at best heading. The ship is also required to have full capability of all systems at sea state 5, continuous efficient operation at sea state 6, and best heading survival without serious damage at sea state 8. The annual sea state occurrences in North Atlantic are summarized in the Table 22.

**Table 22: Annual Sea State Occurrences in the Open Ocean, North Atlantic<sup>24</sup>**

Sea State	Significant Wave Height (m)	Sustained Wind Speed (Knots)	Percentage Probability of Sea State	Modal Wave Period (sec)
0-1	0.05	3	0.7	-
2	0.3	8.5	6.8	7.5
3	0.88	13.5	23.7	7.5
4	1.88	19	27.8	8.8
5	3.25	24.5	20.64	9.7
6	5	37.5	13.15	12.4
7	7.5	51.5	6.05	15

The spectrum used for the analysis was a Pierson-Moskowitz Spectrum with significant wave height 3.25 m, which corresponds to sea state 5. A spectrum describes the allocation of the variance or energy of a wave system among its components. The

Pierson-Moskowitz Spectrum represents fully developed seas and is described by the following formula:

$$S(\omega) = \frac{\alpha \cdot g^2}{\omega^5 e^{\beta \left( \frac{g}{h_{1/3} \omega^2} \right)^2}}$$

Where

$\omega$ = the frequency in rad/sec

$\alpha$ = 0.0081

$\beta$ = 0.74

$g$ = acceleration of gravity in m/sec<sup>2</sup>

$h_{1/3}$ = the significant wave height

Motions of the trimaran were analyzed using a Pierson-Moskowitz Spectrum with significant wave height 3.25 m and period 9.7 sec. Since the program has limitations in Froude number ( $U/\sqrt{gL}$ ) and reduced frequency  $\tau$  ( $U\omega_c/g$ ), we could not analyze speeds lower than 12 knots. However, the seakeeping characteristics of a vessel do not vary significantly below that speed. Also limitations of the program prevented the analysis for speeds above 30 knots.

As previously stated, the ship is required to be fully operational at sea state 5. The limiting criteria for personnel sea sickness and their locations are presented in Table 23. The vessel is also required be able to conduct flight operations at sea state 5 at best heading. The limiting criteria are presented in Table 24.

**Table 23: Limiting Criteria for Personnel Seasickness**

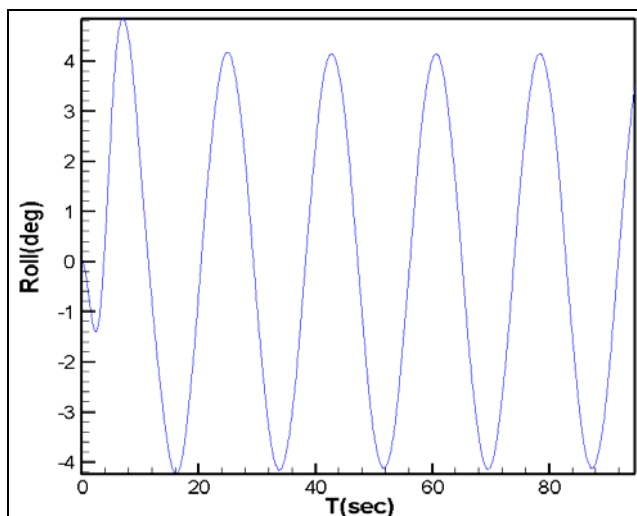
Motion	Location	Limit
Roll	CG	8 deg
Pitch	CG	3 deg
Vertical Acceleration	Bridge	0.4 g
Lateral Acceleration	Bridge	0.2 g

**Table 24: Limiting Criteria for Flight Operations**

Motion	Location	Limit
Roll	CG	6.4 deg
Pitch	CG	3 deg
Vertical Acceleration	Flight deck	0.15 g

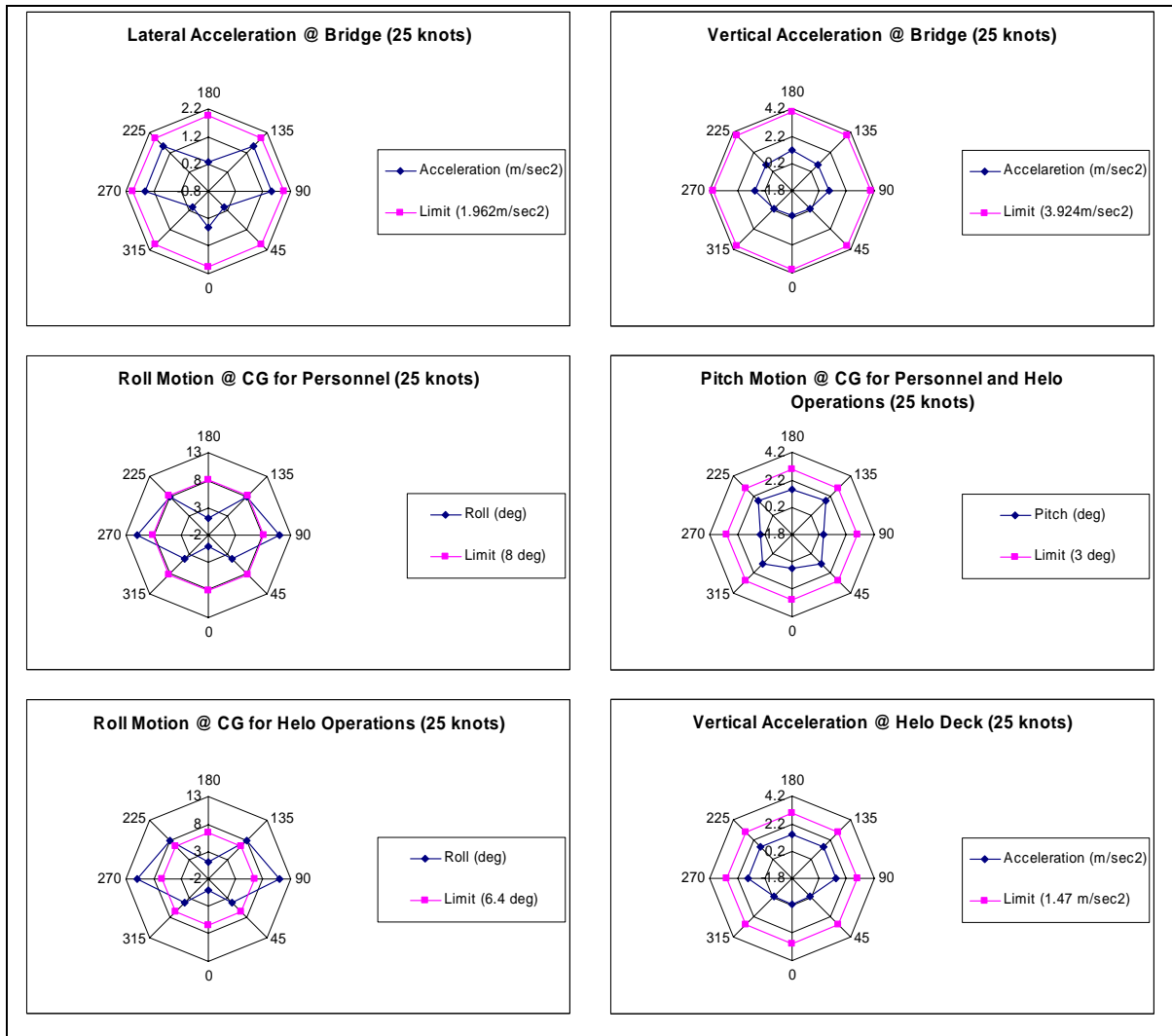
The motions of the ship were analyzed at speeds of 12, 19, and 25 knots at increments of 45 degrees starting from head seas and ending at stern seas. The motions were also analyzed for head seas at a speed of 30 knots. Figure 26 shows an example of the predicted roll motion time history in the case of 19 knots with quartering seas.





**Figure 26: Roll Motion Time History (19knots, quartering seas)**

According to the results of the seakeeping analysis, presented in Appendix I (Note: due to program limitations, no results were produced for some of the cases, and therefore some of the cells are blank), the vessel met all the criteria for personnel sea sickness in most of the examined speeds and headings. The only condition that roll motions exceeded the limit of 8 degrees was at beam seas and at 19 and 25 knots, where the maximum roll angle was 10 and 11 degrees respectively. At this point we have to note that the seakeeping analysis program that was used did not have the option to examine hulls fitted with bilge keels. In the final design the team decided to add bilge keels at the main hull, which will significantly reduce roll motions. The lateral and vertical accelerations at the bridge were within the limits in all the examined conditions. An example of the response and the limits is presented in Figure 27, which shows the motions and limits for roll, pitch and accelerations at the bridge for the speed of 25 knots with various headings (0 deg represents the stern of the ship and 180 deg the bow). In addition, the personnel motions criteria and the motions at 30 knots, head seas, are presented in Table 25.



**Figure 27: Responses and Limits at 25 knots**

**Table 25: Motions at 30 knots head seas for personnel sea sickness criteria**

Motion	Location	Values	Limit
Roll	CG	0 deg	8 deg
Pitch	CG	1.5 deg	3 deg
Vertical Acceleration	Bridge	3.12 m/sec <sup>2</sup>	3.92 m/sec <sup>2</sup>
Lateral Acceleration	Bridge	1.51 m/sec <sup>2</sup>	1.96 m/sec <sup>2</sup>

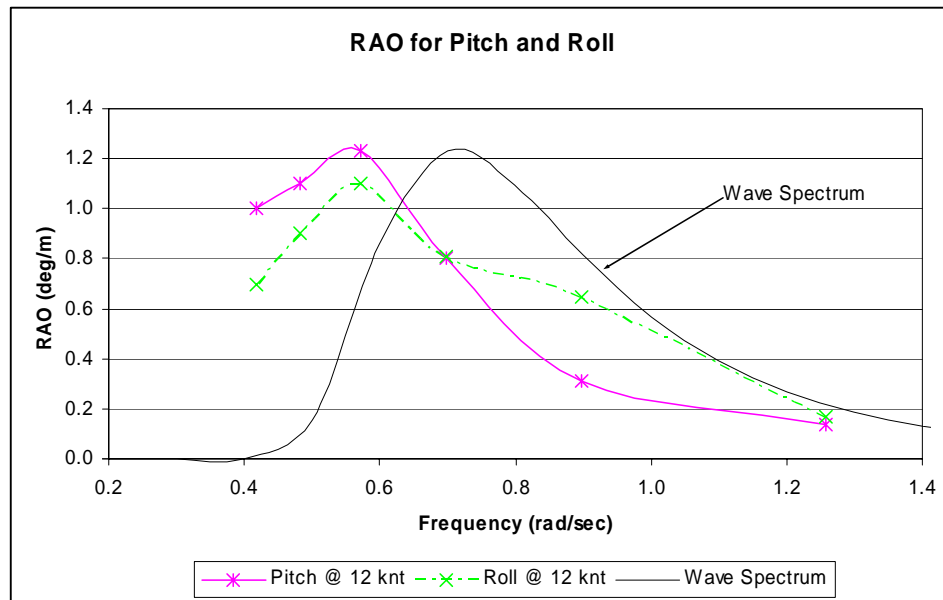
The vessel was designed to meet the goal requirement for flight operations. The vessel should be able to conduct flight operations at sea state 5, at best heading. The vessel was able to meet the requirement in all of the examined speeds. Results are presented as Appendix I.

As it is presented in Figure 27, at stern seas, or at seas coming from 45 deg from the stern, all the motions are within the limits. At the other headings the only limitation that was exceeded was the roll motion limitation. With the addition of bilge keels this motion is expected to be significantly reduced. At speeds of 12 and 19 knots, all the motions and accelerations were below the limits. The motions and accelerations at flight deck for the speed of 30 knots and head seas are satisfactory and are presented in Table 26.

**Table 26: Motions at 30 knots Head Seas for Flight Operations Criteria**

Motion	Location	Values	Limit
Roll	CG	0 deg	6.4 deg
Pitch	CG	1.5	3 deg
Vertical acceleration	Flight deck	1.5 m/sec <sup>2</sup>	1.47 m/sec <sup>2</sup>

SWAN was used to evaluate the RAO's (response amplitude operators) of the trimaran at the speed of 12 knots, head seas. The results were analyzed using Excel. The RAO represents the ratio of the scalar amplitude of the response to the exciting regular wave amplitude. It identifies the resonant frequency of the response and helps the naval architect to design the vessel to avoid having a resonant frequency close to the dominant frequency of the wave spectrum. Figure 28 shows the RAO's for pitch and roll at the speed of 12 knots with head seas, as well as the Pierson-Moskowitz Spectrum. The highest values of the RAO's are not close to the highest value of the spectrum and therefore we should not expect resonance.



**Figure 28: Response Amplitude Operators for Pitch and Roll @ 12 knots, Head Seas**

In addition, one of the design choices that are very important for the seakeeping performance of the trimarans is the draft of the side hulls. One philosophy suggests the

use of deep side hulls with draft 0.4 to 0.5 of the main hull draft, as with the RV Triton, but this philosophy is not universally accepted.

The advantage of the shallow side hulls is the lower resistance compared to deep side hulls. The disadvantage is the requirement for an additional ballasting system for the ship to maintain constant draft at the light load condition. In addition, the use of shallow side hulls imposes the risk of parametric resonance in head seas as a result of the large periodic GM variation at approximately twice the roll natural frequency.<sup>25</sup> GM increases when the wave crest is at the side hulls and decreases when the side hulls are in a trough. The GM variation can cause resonance and can lead to severe rolling of the vessel. The risk of parametric resonance can be reduced by careful selection of the side hull shape and dimensions. Deep side hulls minimize the GM variation, and hence the risk of parametric rolling. Therefore, the draft of the side hulls was selected to be 2 meters, which is the 0.47 of the main hull draft.

The Focused Mission High Speed Combatant shows a good seakeeping performance even though the motions were examined without the use of bilge keels that will be fitted in the vessel. The personnel sea sickness criteria were met in most of the cases, and for all the examined speeds there were headings that flight operations could be conducted at sea state 5. Pitch and heave motions are expected to be smaller than those of an equivalent monohull and the RAO's at the examined speed show that resonance should not be expected.

#### 4.1.5.4 Resistance

Standard estimating methods have been developed to estimate the resistance of a monohull. These techniques are not appropriate, however, to estimate the resistance of a trimaran. Trimaran resistance includes hull interaction effects that are not present in monohull techniques. Therefore, a new, rational approach for the calculation of trimaran resistance was developed to account for the multiple hulls.

The total resistance of the ship can be calculated as a sum of frictional resistance, residuary resistance (wave-making resistance), and form resistance.

#### **Frictional Resistance**

The calculation of Frictional Resistance was based on the ITTC 1957 formula, which calculates the non-dimensional frictional coefficient as a function of Reynolds number.

$$C_F = \frac{0.075}{(\log_{10} R_N - 2)^2}$$

The Displacement Hull Design Tool provides the wetted surface areas of the side hulls and the main hull. The total frictional resistance is calculated by the following formula, and the values are presented in Table 27.

$$R_{Frictional} = \frac{1}{2} C_{F\_Mainhull} \rho V^2 WSA_{Mainhull} + 2 \frac{1}{2} C_{F\_Sidehull} \rho V^2 WSA_{Sidehull}$$

#### **Wave-making Resistance**

The wave resistance of the trimaran was calculated using SWAN, which determines the resistance by a wake analysis that evaluates the momentum deficit in the Kelvin wake. SWAN was selected since it is able to capture the interaction effects between the main hull and the side hulls. The resistance predictions of SWAN show good agreement

with experimental data at Froude numbers greater than 0.3. At Froude numbers lower than 0.3, SWAN over-predicts the wave-making resistance and a different approach is required.

The resistance prediction method of the Displacement Hull Design Tool was used for the calculation of resistance for Froude numbers lower than 0.3. This method uses Series 64 data and adds a factor of the side hull residuary resistance (10% was used in our case) to account for the interaction effects between the hulls. The estimated data of wave-making resistance are presented in Table 27.

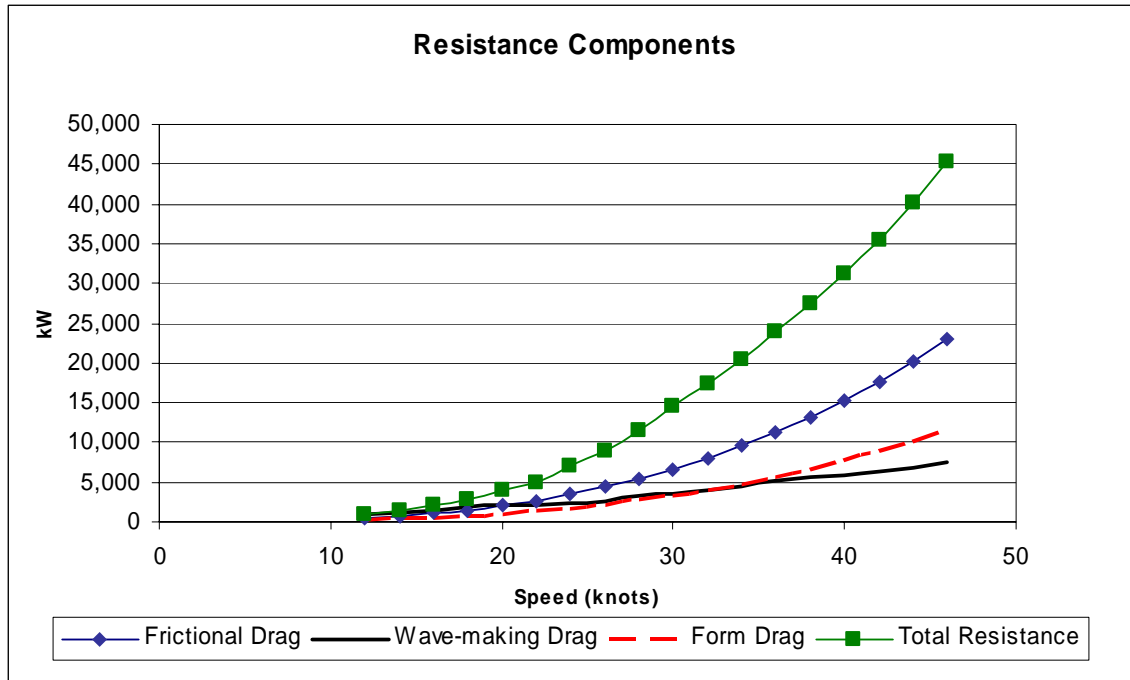
### Form Resistance

The form resistance is primarily of viscous nature and cannot be calculated using SWAN. For transom stern ships, like the designed trimaran, a significant component of the form drag arises from the generation of free surface vorticity. This vorticity is responsible for a big percentage of the form drag that is difficult to calculate.<sup>26</sup> In this analysis the form drag was estimated as a percentage of the frictional resistance. Experts suggested that the most probable value of form drag was 50% of the frictional resistance. This value was used for the resistance analysis and the results are presented in Table 27.

**Table 27: Resistance Data**

Speed (knots)	Froude Number	Frictional Resistance (kW)	Wave Making Resistance (kW)	Form Drag (kW)	Total Resistance (kW)
12	0.16	464.85	823.85	232.43	973.15
14	0.19	726.88	1,081.12	363.44	1,461.76
16	0.22	1,070.80	1,481.99	535.40	2,132.97
18	0.24	1,507.20	1,815.83	753.60	2,873.81
20	0.27	2,046.53	2,020.44	1,023.26	3,921.43
22	0.30	2,699.15	2,157.56	1,349.57	4,969.04
24	0.32	3,475.34	2,363.55	1,737.67	8,182.68
26	0.35	4,385.31	2,695.46	2,192.66	10,015.30
28	0.38	5,439.20	3,197.95	2,719.60	12,265.29
30	0.41	6,647.08	3,579.33	3,323.54	14,633.95
32	0.43	8,018.97	4,044.55	4,009.48	17,358.84
34	0.46	9,564.84	4,565.00	4,782.42	20,425.23
36	0.49	11,294.60	5,177.93	5,647.30	23,889.41
38	0.51	13,218.13	5,566.52	6,609.06	27,425.21
40	0.54	15,345.25	5,805.97	7,672.63	31,129.76
42	0.57	17,685.77	6,224.66	8,842.88	35,373.57
44	0.59	20,249.43	6,802.68	10,124.71	40,150.96
46	0.62	23,045.94	7,399.29	11,522.97	45,325.66

Finally, a correlation allowance  $C_A=0.0004$ , and a power margin of 8% were added to the described components in order to calculate the total resistance. Figure 29 shows the different components, as well as the total trimaran resistance.



**Figure 29: Resistance Components**

#### 4.1.5.5 Propulsion

##### 4.1.5.5.1 Machinery Plant Description

The ship uses an electric drive arrangement consisting of two gas turbines and two diesel engines connected to propulsion generators by gear box assemblies. Either the gas turbines or the diesels can be used for propulsion. The gas turbines are expected to be used for high speed operations and the diesels are expected to be used for low speed operations. The power from the propulsion generators is routed to four water jet motors that each power one water jet. As with many electric drive systems, the power from the propulsion generator can also be routed to other uses on the ship when not being utilized for propulsion. Table 28 lists the major machinery plant components and their ratings.

The machinery plant design is very conservative and can be improved significantly in later design iterations.

**Table 28. Major Machinery Plant Components**

Function	Machinery	Qty	Rating
Propulsion	LM 2500+ Gas Turbine	2	26.10 MW
	MTU/DDC 16V-4000 M90 Diesel	2	2.72 MW
	Propulsion Generator	2	38.49 MW
	Water Jet Motor	4	13 MW
	Water Jet	4	12.79 MW
Ship's Service Power	Caterpillar 3615B Diesel Generator	4	1.79 MW

#### 4.1.5.5.2 Propulsor Description

The ship uses 4 waterjets for propulsion. These waterjets were sized by the Displacement Hull Design Tool using a spreadsheet prepared by Band, Lavis and Associates to design waterjets with user input of power, ship speed, and elevation above waterline.<sup>27</sup> The four waterjets each provide 8.6 MW of power for a total of 34.44 MW.

#### 4.1.5.5.3 Machinery Arrangements

The major machinery plant components are arranged among six machinery rooms. These rooms and their major contents are listed in Table 29, with the machinery rooms listed in order from fore to aft. The first Main Machinery Room and the second Auxiliary Machinery Room are separated by a compartment to ensure that damage up to 15% of the length between perpendiculars does not cause loss of all main machinery or electrical generating power. The water jets and their motors are susceptible to loss from the design damage, but the probability of total loss is reduced by placing the water jet motors in two separate compartments and by taking advantage of the protection provided by locating the side hulls at the aft end of the ship.

**Table 29. Machinery Arrangements**

Machinery Room	Major Contents
AMR1	2 Caterpillar 3516B SSDG's
MMR1	GE LM 2500+ MTU/DDC 16V-4000 M90 Propulsion Generator
AMR2	2 Caterpillar 3516B SSDG's
MMR2	GE LM 2500+ MTU/DDC 16V-4000 M90 Propulsion Generator
Water Jet Motor Room	2 Water Jet Motors
Water Jet Room	4 8.6MW Water Jets 2 Water Jet Motors

#### 4.1.5.5.4 Determination of Ship Speed

The total mechanical output of the Gas Turbines (BHP) is 52.2 MW. The assumed efficiencies at the maximum speed are listed in the following Table 30.

**Table 30: Propulsion System Efficiencies**

Generator Efficiency ( $n_G$ )	0.99
Electrical Transmission Efficiency ( $n_{E_T}$ )	0.98
Motor Efficiency ( $n_M$ )	0.99

The SHP is calculated by the following formula:

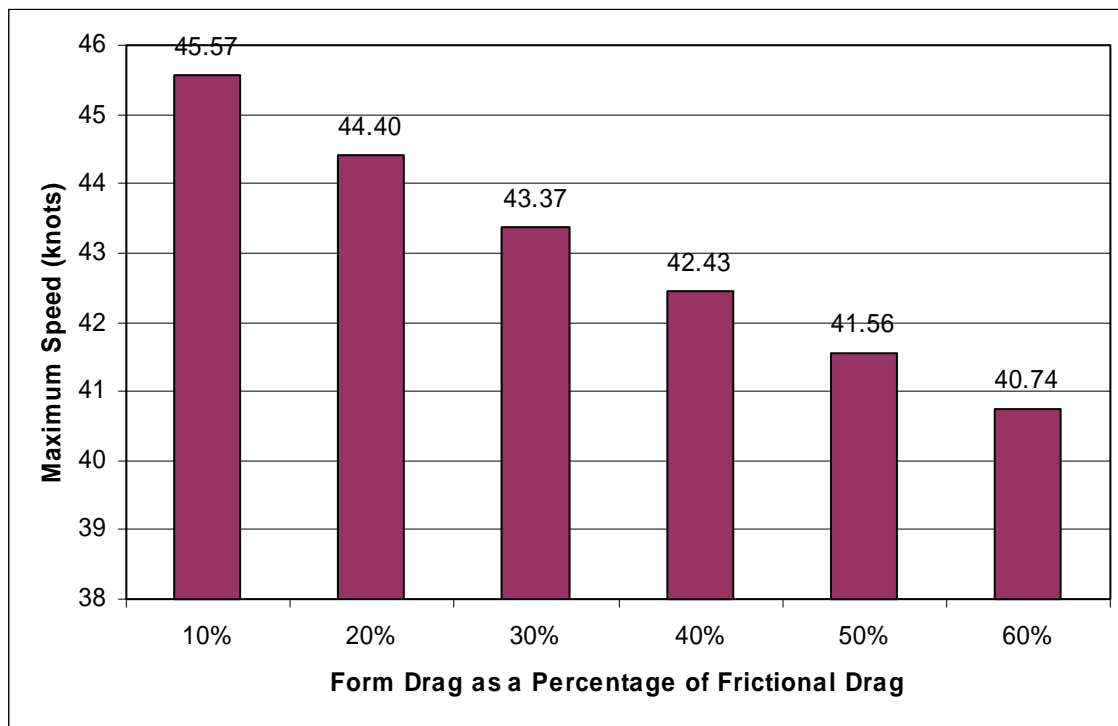
$$SHP = BHP \cdot n_G \cdot n_{E-T} \cdot n_M$$

The shaft horsepower (SHP) is related to the EHP by the propulsive coefficient (PC). The total EHP is calculated by the following formula:

$$EHP = SHP \cdot PC$$

Using the waterjet calculations done by the Displacement Hull Design Tool, the total PC was calculated to be 0.688, which gives an EHP at burst condition equal to 34.44 MW. The form drag was calculated as 50% of the frictional drag. The resulting calculated speed is 41.6 knots. However, the uncertainty associated with the form resistance prediction requires an uncertainty analysis of the total drag.

One simple approach of the uncertainty analysis is presented in Figure 30, which shows how the maximum speed changes with the variation of form drag as a percentage of the frictional drag.



**Figure 30. Maximum Speed for Different Values of Form Drag.**

A more detailed uncertainty analysis can be done with the use of a Monte Carlo simulation. A Monte Carlo simulation is a random number generator that provides values for each of the uncertain variables. Values are selected within a specified range, and with a frequency which depends on the shape of the probability distribution of the variable. The steps of a Monte Carlo simulation are the following<sup>28</sup>:

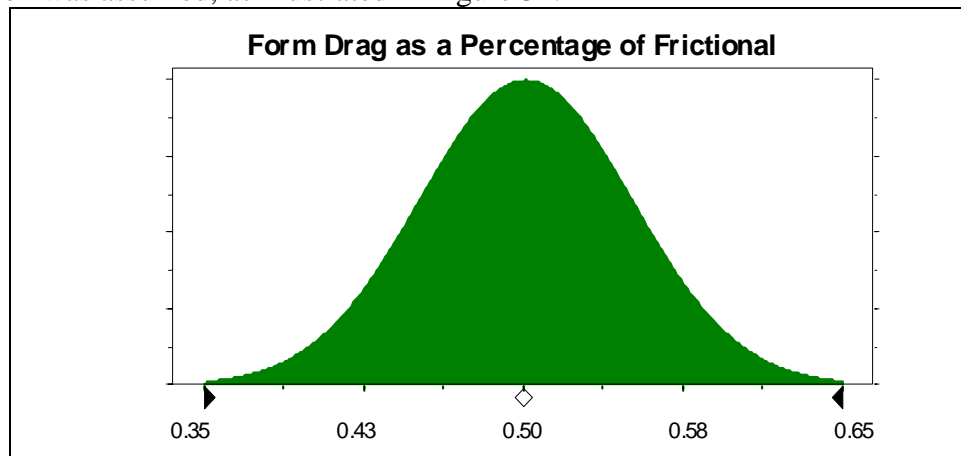
- 1) Define the probability distributions of the uncertain variables.
- 2) For each of the uncertain variables, randomly select a value from the distribution function.
- 3) Combine all the values of all the uncertain variables, and calculate the result based on the given mathematical relationships.



- 4) Repeat the above procedure n-times. Each cycle produces an output value based on the given relationships.
- 5) Develop a frequency distribution of the output value, based on the n calculated outputs.

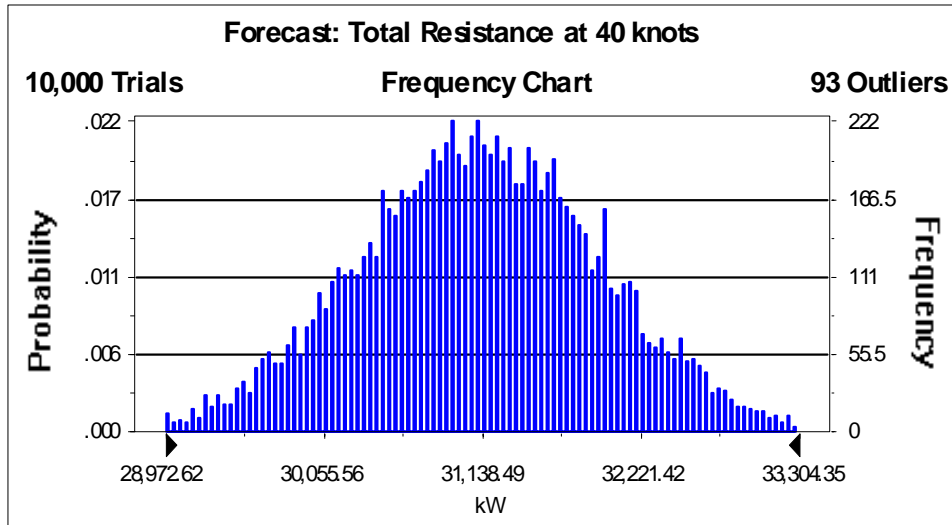
Usually 1,000 to 10,000 cases are necessary for a good representation of the probability distribution.<sup>29</sup> The Monte Carlo simulation, for the purpose of this study, was performed with the aid of software called Crystal Ball, by Decisioneering Inc., which randomly generates numbers for the uncertain variables, based on user-defined probability distributions, and computes the probability distribution of the response.

As previously mentioned the most probable value of form drag was 50% of the frictional drag. Therefore, a normal distribution with the mean at 50% and 5% standard deviation was assumed, as illustrated in Figure 31.

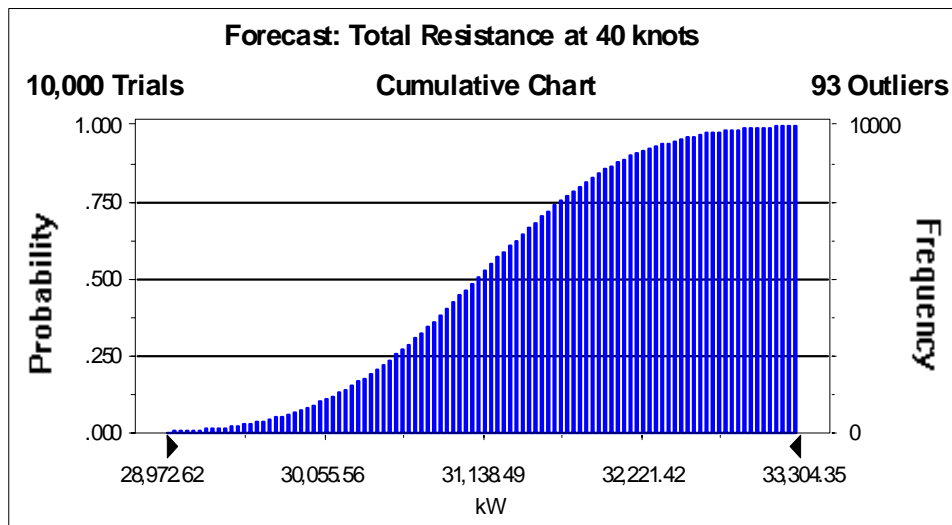


**Figure 31: Form Drag Probability Distribution**

After running a simulation of 10,000 cases Crystal Ball gave the probability distributions of the total resistance in 40, 42 and 44 knots. Figure 32 shows the distribution of total resistance and, since the EHP is 34.44 MW, we can conclude that there is 100% certainty that the maximum speed of the ship will be above 40 knots. This can be presented more clearly by Figure 33, the cumulative distribution of total resistance at 40 knots. The cumulative chart displays the probability of achieving a total resistance lower than or equal to any given value on the x-axis.

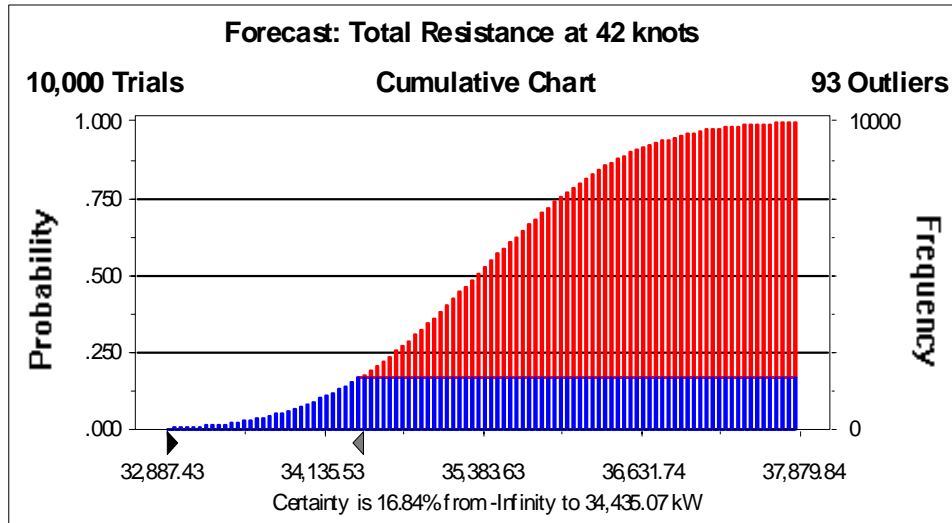


**Figure 32: Distribution of Total Resistance at 40 knots**

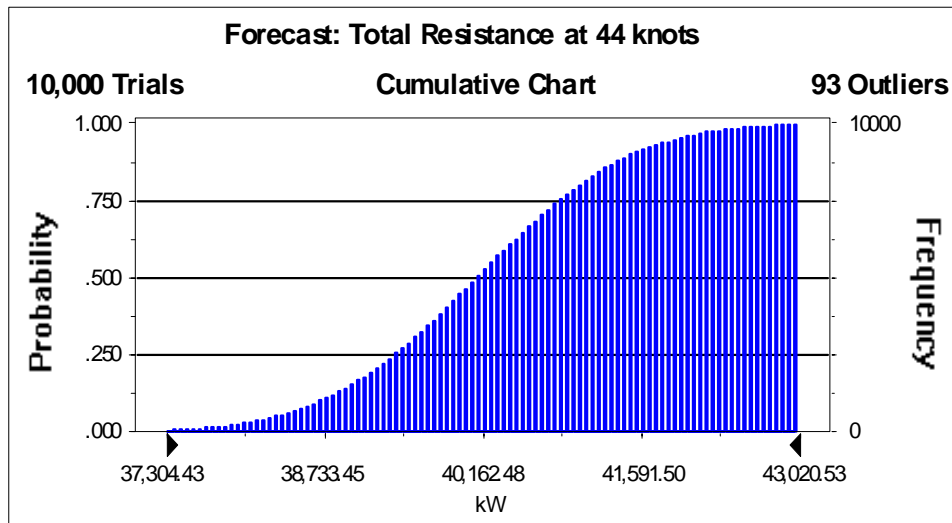


**Figure 33: Cumulative Distribution of Total Resistance at 40 knots**

The cumulative charts of the total resistance at 42 and 44 knots are presented in Figure 34, and Figure 35, which show that there is a 17% certainty that the maximum speed of the vessel will be above 42 knots, and a 0% certainty that the maximum speed will be above 44 knots.



**Figure 34: Cumulative Distribution of Total Resistance at 42 knots**



**Figure 35: Cumulative Distribution of Total Resistance at 44 knots**

A similar analysis can be performed for the endurance speed, but since the Displacement Hull Design Tool resistance calculations were used for this speed range, no uncertainty analysis was performed.

The diesel engines are used for endurance speed. The maximum mechanical output of the diesel engines is 1.33 MW. Using the same efficiencies as before and a total PC equal to 0.658, the EHP for the endurance condition is 3.4 MW which drives the ship at an endurance speed of 19 knots.

The required fuel carried on board was calculated based on the endurance speed, the required endurance range (3,500 nautical miles), and the required fuel for the ship service generators. The calculated value of the total fuel is 270 tons, which at the burst condition (using the fuel consumption of Gas Turbines) gives a range of approximately 1000 nautical miles.

#### 4.1.5.6 Electric Load Analysis

The electrical load analysis was performed using ASSET. The results showed that the maximum margined electrical load is 3677 kW. The four installed Caterpillar 3612B Ship Service Diesel Generators can provide 1790 kW of electrical power each for a total of 5370 kW with one SSDG off line or 7160 kW with all generators on line.

The electrical loading requirements are included as Appendix J.

#### 4.1.5.7 Environmental Considerations

The ship's effect on the environment is minimized by reducing the sound emissions from the major machinery components and by utilizing clean ballast systems. The sound emissions are reduced in order to enhance crew quality of life and reduce the ship's acoustic signature. These reductions are achieved by mounting the machinery on insulating flexible sound mounts and by enclosing the machinery in sound insulating capsules. This is especially important on this small ship because of the necessity of locating berthing spaces near the machinery rooms. Sound insulation will also be installed in the berthing spaces to enhance habitability.

This ship design utilizes standard Navy practices for solid waste, graywater, and engine emissions.

#### 4.1.6 Survivability and Signatures

The survivability of a ship can be assessed in terms of susceptibility, vulnerability, and recoverability.

##### 4.1.6.1 Susceptibility

The susceptibility of a ship is the degree to which the ship is open to attack due to inherent features of the ship. The susceptibility of a ship can be reduced by reducing the signatures of the ship such as radar cross-section, acoustic signature, and visual signature.

The radar cross-section of the ship has been reduced by using a composite material for the superstructure, by placing a  $10^\circ$  angle on the front and sides of the superstructure and by reducing the number of projections and surfaces in the superstructure. Further reduction has been achieved by using an Advanced Enclosed Mast System and selective application of radar absorbent paint and materials.

The visual signature of the ship is reduced by using low-visibility paint scheme, and by routing the exhaust of the equipment in the aft machinery rooms to the water in the space between the hulls. The exhaust plume will be significantly reduced during loiter and low speed operations, but the forward machinery room will produce visible exhaust during high speed operations. Consideration was given to introducing devices to reduce the infrared signature of the exhaust stacks, but that technology was not predicted to be sufficiently mature for effective fielding in 2005.

The acoustic signature of the ship was reduced by mounting major machinery on sound isolating mounts. The water jets, however, remain a significant source of noise.

The magnetic signature of the ship is reduced using a degaussing system.

#### 4.1.6.2 Vulnerability

The vulnerability of a ship is the degree to which the ship's capabilities suffer degradation as a result of enemy action. The vulnerability of the ship has been reduced through careful arrangements and subdivision.

##### 4.1.6.2.1 Arrangements

The arrangements for the ship have been made with survivability in mind. The crew berthing is divided into two separated spaces. The Combat Information Center is placed low in the ship to reduce the probability of combat damage. The flexible mission areas are located in the protected stern of the ship. Propulsion and electric plant components have been distributed to prevent a single hit from preventing a loss of all propulsion or electrical power.

##### 4.1.6.2.2 Hull Subdivision

The bulkheads are located to ensure that the ship maintains reserve buoyancy even if damage occurred over 15% of the ship's length. In the stern of the ship, reserve buoyancy is provided by the side hulls.

##### 4.1.6.3 Recoverability

The recoverability of the ship is a measure of the ability of the ship to regain mission effectiveness after sustaining attack. Recoverability is enhanced by careful placement of damage control resources such as repair lockers, firefighting stations, and Damage Control Central. The repair lockers and firefighting stations on the Focused Mission High Speed Combatant are at three widely separated locations on the ship. Damage Control Central is located relatively near the stern and is protected by the cross-deck structure for the side hulls.

#### 4.1.7 Manning

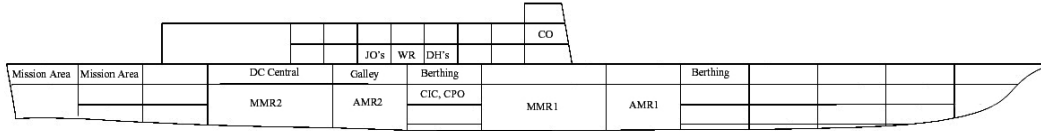
The ship has accommodations for 75 officers and enlisted personnel, male and female. The distribution of these accommodations between core crew and mission specialists was not investigated in detail. Estimates of minimum core crew size range from 15 to 50 personnel. The remainder of the accommodations is for mission specialists.

The ship will utilize Smart Ship technologies to reduce crew manning and improve training opportunities. These technologies have been installed successfully on several warships including USS Yorktown (CG 48) and USS Mobile Bay (CG 53). The seven core technologies of the Smart Ship Program are: the Integrated Bridge System (IBS), Integrated Condition Assessment System (ICAS), the Damage Control System (DCS), the Machinery Control System (MCS), the Fuel Control System (FCS, a fiber-optic local area network (LAN), and the Wireless Internal Communication System (WICS). These systems come with an embedded On-Board Trainer (OBT).<sup>30</sup>

Figure 36 shows the arrangement of living spaces in relation to the other major areas on the ship. The majority of the berthing and living spaces are centrally located on the ship for crew comfort. Approximately one third of enlisted berthing is in a separated berthing compartment to reduce the crew loss that could be obtained from a single hit. The Commanding Officer's Cabin is directly beneath the bridge to allow for rapid access and continuous monitoring of bridge conditions. Department Heads and Junior Officers

are berthed near the Wardroom with ready access to Damage Control Central, the Bridge, and the Combat Information Center.

Mission Specialists will be berthed in the same spaces as the ship's core complement. Areas within the berthing compartments will be designated for these specialists.



**Figure 36. Berthing and Living Spaces.**

#### 4.1.8 Structural Analysis

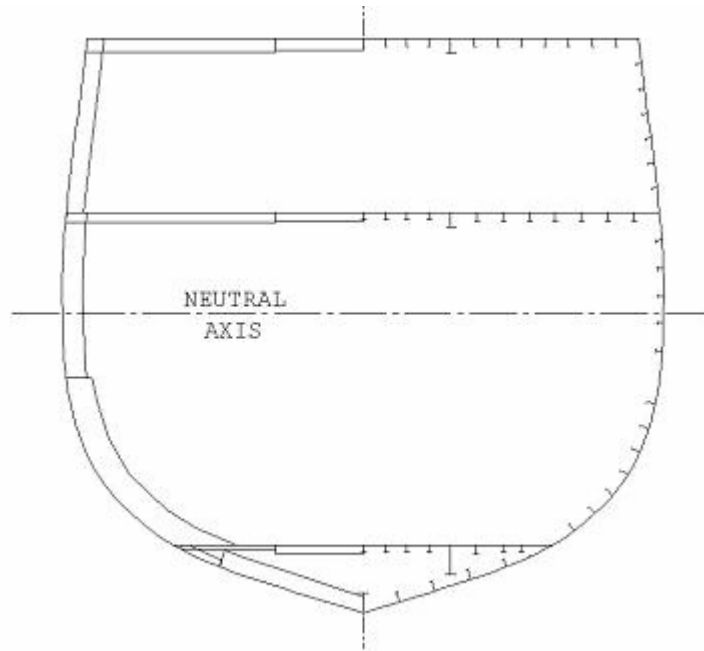
Structural analysis of the ship was done using POSSE.

##### 4.1.8.1 Weight Distribution

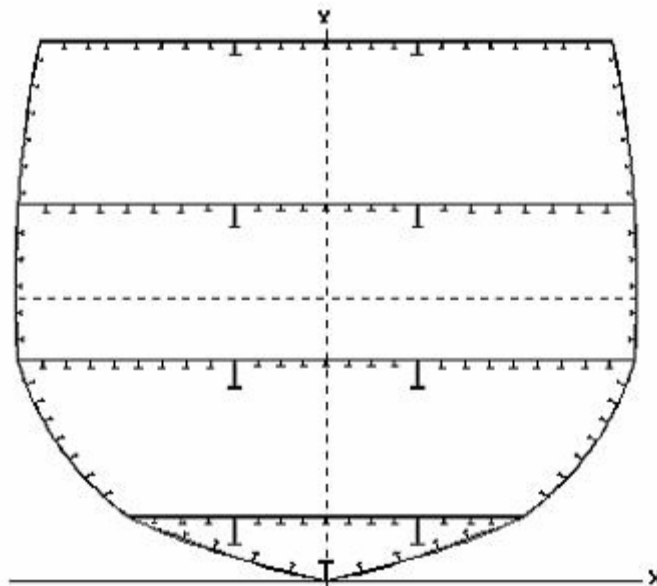
A ship data file was created in order to obtain the Ship's Weight Distribution Curve. A ship data file describes the ship's hydrostatics, cargo and tank arrangements, and the longitudinal strength. It is also used to configure the loading options of stability and strength calculations in the Intact Loading and Salvage Response Programs. The light ship weights were added as blocks of weight along the hull to represent the modeled ship's lightship weight and longitudinal center of gravity (LCG). The lightship weight information is included as part of Appendix K.

##### 4.1.8.2 Midship Section Construction

The construction of the midship section was done based on the ASSET Hull Structure Module Reports describing the arrangement of the midship section as well as information about the structural elements (decks, shells, stiffeners and girders). The plate thicknesses used were: 12mm for the weather deck, 8mm for the internal decks and the side shells and 12mm for the bottom shell. The dimensions of the stiffeners and the girders varied according to the values taken from the ASSET reports. Figure 37 displays the midship section given from ASSET and Figure 38 is the same cross section developed in POSSE. The graph of the segment points as well as the structure report from ASSET is in Appendix K as well as the details describing the final midship section designed using POSSE.



**Figure 37 Midship Section Drawing Generated by ASSET**



**Figure 38. Final Midship Section Designed Using in POSSE**

#### 4.1.8.3 Structural Analysis of the Hogging and Sagging Loading Cases

In order to analyze the ship's structural capacity the ship is subjected to a trochoidal wave. The wave has a length of 148m (ship's length) and a height of 13.4m ( $1.1 * \sqrt{\text{LBP}}$ ). The cases examined at this point were hogging and sagging. In the first case, the crest of the wave is at midship, while in the latter the trough is at midship. The maximum and minimum loading conditions described earlier for intact stability analysis are examined. Table 31 shows the summary of the results for hogging and sagging. For bending stress, the “-“ sign denotes tension and the “+” denotes compression.

**Table 31. Bending Stress Summary for Hogging and Sagging**

	Case	Max Shear Stress (Ksi)	Max Bending Stress at Deck (Ksi)	Max Bending Stress at Keel (Ksi)
Minimum Load Condition	Hogging	-0.95	36.19	-25.08
	Sagging	1.39	-28.34	19.64
Maximum Load Condition	Hogging	-1.02	35.42	-24.55
	Sagging	1.38	-30.50	21.14

The original structural design using ASSET used HY-80 steel with a maximum allowable stress of 21 ksi. Table 31 shows that the maximum bending stress for the sagging case exceeds this limit at both the keel and the deck. In order to increase the strength of the structure, the thickness of the plates was changed. Specifically, the shell and internal deck thicknesses were changed to 11 mm. The weather deck and bottom shell thickness were changed to 16 mm. Finally, the stiffeners and the girders of the weather deck were increased in dimensions by a factor of 15%. Table 32 shows that the new values are within the allowable stress limit for HY-80 steel. The increased structural weight is still within the structural weight estimated by the Displacement Hull Design Tool and does not change the design's displacement.

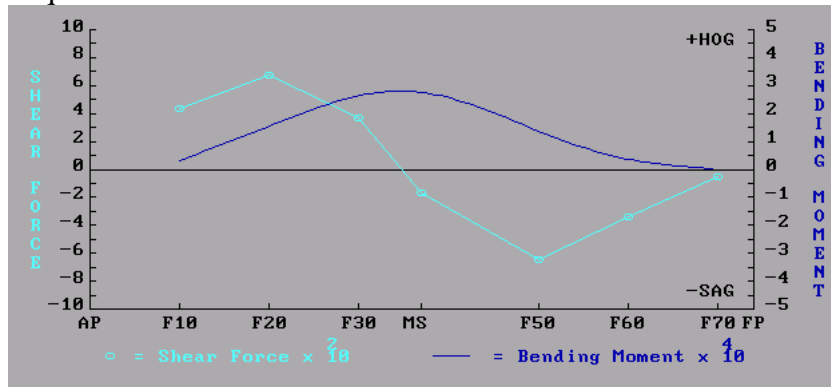
Table 32 also shows the results of the stillwater analysis.



**Table 32. Shear and Bending Stress Summary for Hogging and Sagging in the Maximum and Minimum Loading Conditions with Enhanced Structural Components**

	Case	Max Shear Stress (Ksi)	Max Bending Stress at Deck (Ksi)	Max Bending Stress at Keel (Ksi)
Minimum Load Condition	Hogging	-0.65	20.13	-16.09
	Sagging	0.96	-15.76	12.60
	Stillwater	0.21	5.85	-4.68
Maximum Load Condition	Hogging	-0.70	19.70	-15.74
	Sagging	0.95	-16.96	13.56
	Stillwater	0.18	4.84	-3.87

Figure 39 shows the bending moment and shear stress diagrams for the worst case condition, which is the hogging case in the minimum loading condition. The ship meets all structural requirements under all examined conditions.



**Figure 39. Shear Force and Bending Moment Graph for the Minimum Loading Condition in Hogging**

## 4.2 Cost

The cost model for the Focused Mission High Speed Combatant is based upon the work of Williamson, Kennell and Broadbent at the Carderock Division of the Naval Surface Warfare Center. Their research into the cost of a high speed sealift catamaran yielded the results in the figures shown in Table 33. These figures were estimated based on the advice of industry experts as well as the combined experience of the members of the High Speed Sealift Innovation Cell.<sup>31</sup> These results were the basis for this project's cost model.

**Table 33. Fixed Ship Costs Table<sup>32</sup>**

SWBS Weight Group	Cost per tonne (\$/tonne)
100 (Structure)	40,000
200 (Propulsion)	System Based
300 (Electrical)	85,400
400 (Communications)	50,000
500 (Auxiliary Systems)	75,000
600 (Outfitting)	96,000
700 (Armament)	20,000

The numbers developed by Williamson, et al., were modified for application to this project. The structural cost estimate was developed for advanced composite hull structures built of high-strength materials. Based upon the advice of experts, the team cut the structures price in half for traditional steel construction. The system based cost of the propulsion system was divided by the given power to yield a rough estimate of cost per megawatt for propulsion. Table 34 lists the adapted costs. Table 35 lists the inflation and cost growth factors used. Table 36 shows the results of the cost calculations.

**Table 34. Adapted Fixed Ship Costs Table**

SWBS Weight Group	Cost per tonne (\$/tonne)
100 (Structure)	20,000
200 (Propulsion)	751,944 per MW
300 (Electrical)	85,400
400 (Communications)	50,000
500 (Auxiliary Systems)	75,000
600 (Outfitting)	96,000
700 (Armament)	20,000
Fuel	428
Payload	318,000

**Table 35. Inflation and Cost Growth Factors**

Cost Data Base Year	2002
Calculated Cost FY	2005
Average Inflation Rate	3 %
Inflation Factor	1.093
Detailed Design and Planning Cost	40 %
Growth Factor	15 %
Change Order Factor	5 %

**Table 36. Calculated Costs for the High Speed Focused Mission Combatant**

<b>Cost Analysis</b>	
W100 Cost	\$28,296,610
W200 Cost	\$46,513,178
W300 Cost	\$17,542,126
W400 Cost	\$3,563,048
W500 Cost	\$33,726,986
W600 Cost	\$23,468,562
W700 Cost	\$710,600
Fuel Cost	\$128,974
Total Structural Cost	\$153,950,085
Non-Modular Payload Cost	\$36,347,400
<b>Total</b>	<b>\$190,297,485</b>
Design and Planning	\$76,118,994
Cost Growth	\$28,544,623
Change Orders	\$9,514,874
Post-Delivery Cost	\$0
<b>TLSAC Before Inflation</b>	<b>\$304,475,975</b>
<b>TLSAC After Inflation</b>	<b>\$332,709,119</b>

### 4.3 Risk

The technology to build and operate the ship itself is mature. However, there is some risk associated with the unmanned vehicles. Several of the projected systems are not yet fully mature. The minehunting systems described here have been experiencing some programmatic issues,<sup>33</sup> but the REMUS (Remote Environmental Monitoring UnitS) system is a potential substitute. The REMUS vehicles have been adopted for use by the United States Navy, and others, to locate mines. The REMUS vehicles are smaller than the RMS and LMR systems and have proved themselves to be highly capable platforms.<sup>34</sup>

### 4.4 Operations and Support

The Focused Mission High Speed Combatant will be the first ship in the area of operations and will perform a variety of missions in the area. Each mission requires a specifically tailored set of modules. The critical element in the successful employment of these ships is the staging and maintenance of modules as well as the staging and proficiency of the module support personnel. Although many modules are envisioned to be transportable by helicopter, this may not be the safest means of transferring critical mission equipment as large and heavy as these modules can be.

The best place for the transfer of modules is at a secure forward location ashore. Unfortunately, secure forward locations are not always as close to the area of operations as could be desired. The high speed of the ship will allow it to travel a considerable distance to reconfigure, but it is important to note that the ship can only travel that distance by sacrificing some amount of on-station time due to the amount of fuel expended in transit.

One possible alternative to having a secure forward base is to have a (at least partially) dedicated mother ship for the group of Focused Mission High Speed Combatants. Such a mother ship would carry a wide range of modules as well as the necessary maintenance and support personnel.

## **5. Design Conclusions**

### **5.1 Summary of Final Concept Design**

The final design is summarized in Table 37.

**Table 37. Final Design Summary**

<b>Ship Particulars</b>			
LBP			148 m
Beam (Overall)			21.8 m
Beam (main hull)			11.7 m
Draft			4.32 m
Depth			10.1 m
Displacement (Total)			3,559 mton
Cb (main hull)			0.47
Cp (main hull)			0.66
Sidehull length			22.2 m
Sidehull beam			2.5 m
Sidehull draft			2.0 m
Cl to Cl hull separation			9.65 m
Sidehull Disp. (each)			27 mton
<b>Powering</b>			
Boost Installed			51,156 kW
Endurance Installed			5,331 kW
Service Installed			5,370 kW
Total Installed			61,857 kW
<b>Machinery Data</b>	<b>Type</b>	<b>Number</b>	<b>Engine</b>
Main Engines	GT	2	GE LM2500+
Secondary Engines	Diesel	2	MTU/DDC 16V-4000 M90
Service Engines	Diesel	4	CaterPillar 3516B
<b>Performance Characteristics</b>			
Boost Speed / in waves			41.6 kts
Froude Number (Boost)			0.56
Endurance Speed/Achieved			19.0 kts
Range			3,500 nm
Range @ Boost Speed			1,000 nm
<b>Weights</b>			
Full Load			3,565 mton
Military Payload			364 mton
<b>Cost Analysis</b>			
Total Structural Cost			\$153,950,085
Non-Modular Payload Cost			\$36,347,400
<b>Total</b>			<b>\$190,297,485</b>
Design and Planning			<b>\$76,118,994</b>
Cost Growth			\$28,544,623
Change Orders			\$9,514,874
<b>TLSAC Before Inflation</b>			<b>\$304,475,975</b>
<b>TLSAC After Inflation</b>			<b>\$332,709,119</b>
<b>OMOE Analysis</b>			
Speed Effect			0.054
Range Effect			0.212
Payload Effect			0.285
<b>OMOE</b>			<b>0.550</b>

Table 38 lists the goal and threshold requirements for the Focused Mission High Speed Combatant and how well the design meets those goals.

**Table 38. Overall Measure of Effectiveness of Final Design**

Measure of Performance	Goal	Threshold	Design	Metric
Top Speed	50	40	41.9	knots
Endurance Range at Best Speed	4000	2000	3500	Nm
Payload	394	275	364	ltons
Draft		20	14.2	feet
Modularity	Modularity for mission and for upgradeability	Modularity for mission	Modularity for Mission	
Endurance Duration/Stores	21	21	21	days

The overall measure of effectiveness for the Focused Mission High Speed Combatant is 0.55.

## **5.2 Final Design Assessment**

The Focused Mission High Speed Combatant is a feasible and capable design. The ship's cost is higher than desired, but the desired capabilities are not obtainable for \$220 million. The three most significant lessons learned through this project are

4. Speed Costs: \$220 Million dollars is not enough to buy the capabilities required.
5. Trimaran design presents its own unique complications. The placement and size of side hulls has a dramatic effect on speed and on stability. Special consideration must be given to ensuring the design meets damaged stability requirements with one side hull damaged.
6. The launch and recovery of small craft is a major design driver that must be recognized and planned for early in the design process.

## **5.3 Areas for Further Study**

There are several areas where further study is necessary to improve the design or to ultimately prove its feasibility. The first of these areas is the method of launch and recovery of small craft. Very late in the project the design team discovered that the means of launch and recovery of small craft is a significant design driver. There are several issues which complicate the launch and recovery of small craft. The first of these issues is the physical space and the current design of the launch system. For example, the LMRS is currently launched from a submarine torpedo tube and the RMS is currently launched from a special davit that launches the system on the side of the ship. Another issue is the interaction between the small craft and the wake of the ship. It can easily be understood that the stern of an underway ship with waterjet propulsion can be a difficult place to conduct safe small boat operations. Also, the space between side hulls on a trimaran experiences very complicated fluid dynamics and provides its own challenges. The third major issue is the difficulty experienced by coxswains in aligning their craft with the recovery system. Experts suggest that the most reliable method to conduct launch and recovery of small craft underway is the use of a stern ramp positioned at stern of the ship on the centerline. This minimizes the relative motion between the ship and the boat due to roll.

Future work should include the investigation of a modification to the design presented here to conduct launch and recovery operations in a manner developed by the Innovation Cell at the Carderock Division of the Naval Surface Warfare Center. The Innovation Cell proposes adding a means of low speed propulsion to the side hulls and adding a launch and recovery ramp at the stern of the ship on the centerline. The side hull propulsion would remove the interference from the waterjets during launch and recovery operations.

Other areas of future work include:

- 1) Optimization of the propulsion plant design. The current design is highly conservative.
- 2) Analysis of the effects of shock on the ship and, specifically, the cross-deck structure.
- 3) Evaluation of the use of syntactic foam for damaged stability, especially its resistance to damage from hostile fire.
- 4) Detailed structural analysis of the cross-structure using a finite element model.
- 5) Detailed evaluation of the logistics and support necessary. The modular system will not work if the modules are not where they are needed when they are needed.
- 6) Development of a database of large trimaran and catamaran designs to support parametric analysis and modeling.
- 7) Development of a reliable hull type comparison tool.
- 8) Improved resistance modeling for the transom stern.
- 9) More detailed arrangements plans to validate the usefulness of the narrow forward portion of the main hull.

## **Acknowledgements**

The design team for the Focused Mission High Speed Combatant wishes to extend their deep appreciation for the assistance and support of Mr. Jeff Koleser of Naval Sea Systems Command and Dr. Colen Kennell of the Carderock Division of the Naval Surface Warfare Center. Nigel Gee, Paul Mentz, Chris Broadbent, CDR Al Elkins and CDR Timothy McCue also provided invaluable assistance in the research.

Additional assistance and support were provided by Professor Paul Sclavounous, Eric Maxeiner, and Kelly Malkin.

## **Endnotes**

---

<sup>1</sup> Department of Defense, Quadrennial Defense Review Report (Washington, D.C.: US Government Printing Office, 2001).

<sup>2</sup> Ibid.

<sup>3</sup> Ibid.

<sup>4</sup> Ibid.

<sup>5</sup> OPNAVINST C3501.2J Naval Warfare Missions Areas & Required Operational Capabilities and Projected Operational Environment (ROC/POE) Statements (U).

- 
- <sup>6</sup> Goggins, David A., "Response Surface Methods Applied to Submarine Design," Master's Thesis, Massachusetts Institute of Technology, September. 2001.
- <sup>7</sup> Schmidt, Stephen R. and Robert G. Launsby, Understanding Industrial Experiments, Air Academy Press and Associates, 4<sup>th</sup> edition, 1988.
- <sup>8</sup> Williamson, Matthew, Dr. Colen Kennell, Chris Broadbent, "An Investigation of the Comparative Costs of High Speed Sealift Versus Airlift," Presented at the International Conference: High Speed Craft Technology and Operation, Royal Institution of Naval Architects, London, UK, November 11-12, 2002.
- <sup>9</sup> Broadbent, Chris, Dr. Colen Kennell, "Monohull, Catamaran, Trimaran & SES High Speed Sealift Vessels", 6<sup>th</sup> International Conference on Fast Sea Transportation (FAST 2001), Southampton, UK, 4-6 September 2001.
- <sup>10</sup> Griethuysen, W J van, RW G Bucknall, JW Zhang, "Trimaran Design- Choices and Variants for Surface Warship Applications" , Presented at the International Symposium: Warship 2001: Future Surface Warships, London, UK, June 20-21, 2001.
- <sup>11</sup> Ibid.
- <sup>12</sup> American Bureau of Shipping, Guide for Building and Classing High Speed Naval Craft 2002, Houston, Texas: ABS, 2002.
- <sup>13</sup> International Maritime Organization. 2000 HSC Code: International Code of Safety for High-Speed Craft. London: IMO, 2001.
- <sup>14</sup> Lewis, Edward V., ed., Principles of Naval Architecture, Vol III, Society of Naval Architects and Marine Engineers, 1989.
- <sup>15</sup> Zwang, J., "Design and Hydrodynamic Performance of Trimaran Displacement Ships", Doctoral Thesis, University College London, 1997.
- <sup>16</sup> Zwang.
- <sup>17</sup> Galanis K., Price S., Bebermeyer R., "LHA(R): Amphibious Assault Ships for the 21<sup>st</sup> Century". 13.414 MIT Design Project, 2002.
- <sup>18</sup> Ackers B., Michael T. J., Tredennick O. W., Landen H. C., Miller E. R., Sobowsky J. P., Hadler J. B., "Investigation of the Resistance Characteristics of Powered Trimaran Side-Hull Configurations", SNAME Transactions, Volume 105, 1997.
- <sup>19</sup> Ackers, et al.
- <sup>20</sup> Gillmer, T. C., and Johnson B., Introduction to Naval Architecture, Naval Institute Press, 1982.
- <sup>21</sup> . Griethuysen, et al.
- <sup>22</sup> Zwang.
- <sup>23</sup> Earls C. P., Kirkpatrick G. W., Renick D. H., "Modular Trimaran Warship", 13.414 MIT design project, 1999.
- <sup>24</sup> Lewis.
- <sup>25</sup> Griethuysen, et al.
- <sup>26</sup> "SWAN User Manual", Boston Maritime Consulting Inc., 1999
- <sup>27</sup> Broadbent and Kennell.
- <sup>28</sup> Garvey, P. R., Probability Methods for Cost Uncertainty Analysis. The Systems Engineering Perspective, Marcel Dekker, Inc. 2000.
- <sup>29</sup> Decisioneering Inc. "Crystal Ball 2000. Users Manual"
- <sup>30</sup> Freedner, Scott, John Imbesi, and Leslie Spaulding, "Smart Ship Installations in Full Swing; SSES is Supporting," WAVELENGTHS, November, 2000.



---

<sup>31</sup> Williamson, Kennell and Broadbent.

<sup>32</sup> Williamson, Kennell and Broadbent.

<sup>33</sup> Sullivan, Paul. Personal Interview. April 22, 2003.

<sup>34</sup> [www.whoi.edu/home/marine/remus\\_main.html](http://www.whoi.edu/home/marine/remus_main.html)

# Appendices

## **A. Mission Need Statement**

# Mission Need Statement For Focused Mission High Speed Combatant

## **Defense Planning Guidance Element**

This Mission Need Statement (MNS) provides requirements for a focused mission, high-speed combatant for the 21<sup>st</sup> Century. The Focused Mission High Speed Combatant must operate wherever required, particularly in littoral waters, to enable joint maritime expeditionary force operations. The mission capabilities must be fully interoperable with other naval, interagency, joint, Coast Guard and allied forces.

This unclassified MNS in part addresses the Department of Defense “Defense Planning Guidance, FY 1995-1999,” dated 28 September 1993, requiring the United States to: “...continue to field first rate military forces capable of performing their missions in a wide range of operations,” (p.1) “...capitalize on advanced technology and modernize our weapons and support systems selectively to ensure we retain superior capabilities” (p.14).

This MNS should guide Focused Mission High Speed Combatant design, research, development and acquisition program decisions, service and joint doctrine, and cooperative efforts with United States allies.

## **Mission and Adversary Capabilities Analysis**

**Objectives.** The ship will be a networked, agile, stealthy surface combatant capable of defeating anti-access and asymmetric threats in the littorals. In order to conduct successful missions in an adverse littoral environment, the ship must use innovative weapons, sensors, data fusion, C4ISR, hull form, and propulsion as well as optimal manning concepts, smart control systems, and self-defense systems.<sup>i</sup> The ship will complement the Aegis Fleet, DD(X), and CG(X) by operating in environments where it is less desirable to employ larger higher, more valuable multi-mission ships. Additionally, it will have the capability to operate cooperatively with the United States Coast Guard and other allies.

**Mission.** Primary missions are those that ensure and enhance friendly force access to littoral areas. Access-focused missions will include:

### Primary Missions.

- Prosecution of small boats
- Mine counter measures
- Littoral ASW

### Secondary Missions.

- Intelligence, surveillance and reconnaissance
- Homeland defense / maritime intercept
- Special Operation Forces (SOF) support
- Logistic support for movement of personnel and supplies

### Capabilities.

**Command, Control and Surveillance** – The ship must be fully interoperable with other Naval expeditionary, interagency, joint, Coast Guard and allied forces, and with space and ground sensors. The ship must permit timely and reliable Meteorological and

Oceanographic Conditions (METOC) communication and must have the capability to monitor the environment continuously and precisely, and interface directly with the combat systems and associated Tactical Decision Aid software. The communication suite must have an integrated database capable of interfacing in a Joint Task Force/ Combined Task Force (JTF/CTF) environment to include compatibility with joint systems such as the Global Command and Control System (GCCS), the Joint Worldwide Intelligence Communications System (JWICS) and the Joint Deployable Intelligence Support System (JDISS). It must be designed to be a tactical operational extension using Tactical Command Center (TCC) and Tactical Data Information Exchange System (TADIX) within the emerging Joint Communications Planning Management System. The ship must have a full suite of radios and antennas to support full connectivity via EHF/SHF/UHF SATCOM using full DAMA for each circuit. The ship must have an organic cryptologic capability designed to collect, process and geolocate signals of interest in order to describe and fully exploit the electronic battle space. Cryptologic capability is required to provide near real-time indications and warning and situational awareness to tactical decision makers as well as to support Commanding Officer situational awareness, coordinate actions with other forces and communicate the ship's actions to appropriate commanders. Connectivity must include seamless integration for both organic and off-ship sensor inputs to shooter actions.

Survivability - The ship must be able to protect itself, avoid soft-kill sensors and systems, degrade gracefully, fight hurt and survive. Reduced surface combatant force structure requires nearly "puncture-proof" self defense capabilities as well as inherent survivability. This implies a capability for the Focused Mission High Speed Combatant to be highly successful in environmentally difficult littoral regions at engaging attacking missiles and torpedoes as well as being effective at detecting, locating and avoiding surface, moored and bottom mines. This active defensive capability must be supported by a passive defense capability including stealth design or radar cross-section reduction, signal intercept exploitation, and acoustic signature reduction. Additionally, it must have a highly survivable total ship design with adequate combat suite and ship system redundancy to ensure graceful degradation of capability to make the total loss of the ship highly unlikely even if hit. The ship's design must also minimize manning requirements to reduce the number of personnel placed at risk while providing the maximum defense against exposure to weapons of mass destruction.

Mobility – Speed and agility will be critical for efficient and effective conduct of the littoral missions. The ship must be capable of operating at low speeds for littoral mission operations, transit at economical speeds, and high-speed sprints of approximately 50 knots. High-speed sprints may be necessary to avoid/prosecute a small boat or submarine threat, conduct intercept operations over the horizon or retire from a SOF extraction mission. The design must provide sufficient machinery redundancy for graceful degradation of mobility and survivability. The ship must be able to perform seamanship, airmanship and navigation tasks; prevent and control damage and replenish at sea by both Vertical Replenishment (VERTREP) and underway replenishment and Connected Refueling (UNREP). The ship should capitalize on automated UNREP technologies for all at-sea and in-port commodity handling.

Fleet Support Operations – Conduct in-flight refueling of rotary wing aircraft; conduct Search and Rescue (SAR) operations; and provide routine health care, first aid assistance, triage and resuscitation.

Non-Combat Operations – The ship must provide emergency and disaster assistance, support operations to evacuate noncombatant personnel in areas of civil or international crisis; support and conduct rotary wing aircraft operations; provide unit-level upkeep and maintenance; provide own unit administration and supply support; and maintain the health and well-being of the crew.

Endurance - The ship will have the capability to deploy independently to overseas littoral regions, remain on station for extended periods of time either with a battle group or through a forward basing arrangement and will be capable of underway replenishment.

Organic Vehicles - The ship will rely heavily on manned and unmanned vehicles to execute assigned missions and operate as part of a netted, distributed force.

#### Adversary Capabilities.

As a result of the 2001 Quadrennial Defense Review, the basis of defense planning has been shifted from a threat-based model to a capabilities-based model. The capabilities-based model focuses on how an adversary might fight instead of who that adversary might be. This model recognizes that planning for large wars in distant theaters is not sufficient. The United States must also plan for adversaries who will rely on surprise, deception, and asymmetric warfare to meet their objectives.<sup>ii</sup> Adversary capabilities will expand beyond traditional warfighting and include asymmetric approaches to warfare that employ include terrorism and weapons of mass destruction.

In the past, the large distances between adversaries and the United States have provided a significant level of protection. September 11, 2001 illustrates that the United States can no longer rely upon this geographic insulation. The rise of international travel and trade has made even the United States homeland vulnerable to hostile attack.

Those who articulate and develop national strategy need to consider the rise and decline of regional powers. Many of these states are vulnerable to overthrow by radical or extremist internal forces. Some of them have large armies and the capability to possess weapons of mass destruction. In some states, the governments are unable to prevent their territories from serving as sanctuaries for terrorists and criminals who may pose threats to the safety of the United States. In these cases, “threats can grow out of weakness of governments as much as out of their strength.” These threats do not always possess a national identity.<sup>iii</sup>

Asymmetric warfare, reduced insulation provided by geographical distances, and vulnerabilities of foreign governments result in the need for the United States to maintain the ability to conduct military operations whenever and wherever necessary for the national defense. The ability to conduct operations and gather intelligence in littoral waters will be a key element in assuring access to all possible regions of military conflict.

### **Nonmateriel Alternatives**

United States or Allied Doctrine – Doctrine changes required without a Focused Mission High Speed Combatant would include: Diminished operations in the littoral, inability to project expeditionary force strike power from the sea; severely degraded ability to project precise strike power against land targets; inability to maintain meaningful, visible forward presence for coalition building.

Operational Concepts - A Focused Mission High Speed Combatant, optimized to leverage technology to perform multiple roles in both open ocean and littoral warfare environments, will be needed to execute the operational concepts contained in the Joint Maritime Strategy.

Tactics– Tactics calling for insertion of sea based forces into littoral waters early in a crisis or conflict to deter, contain or control aggression early will entail unacceptable risk to other naval expeditionary and land based forces. Further, these tactics would be based on obsolescent technology through inability to cost-effectively modernize existing surface ships and maintain our technology edge over potential adversaries.

Organization – Increased forward basing and double crewing of contemporary surface ships were deemed to be infeasible alternatives to acquisition of a Focused Mission High Speed Combatant because they would not possess its diverse mission capabilities. These alternatives would provide insufficient assets for crisis management or joint warfighting in a single or nearly simultaneous two major regional conflict contingency.

Training – Future surface combatants must be ready to fight simultaneous multi-warfare engagements in littoral warfare that will proceed so rapidly that crew response times will be insufficient, and place crew and ship at risk. Training alternatives offering the potential to maintain force capability in a smaller force manned with fewer personnel rely heavily on holistic, embedded training. This training capability must be an integral part of the total ship architecture called out as a mission need in a Focused Mission High Speed Combatant. Without the opportunity to implement this training initiative, the Navy will be forced to continue and expand expensive, off-board training programs.

### **Potential Materiel Alternatives**

Alternative design concepts include: (1) New conventional ship designs, (2) A modified repeat DDG 51, (3) Advanced/unconventional hull forms and (4) Modular ship designs.

The ongoing DDG 51 acquisition program could potentially address this need through a modified repeat program by capitalizing on advanced technology. However, to do this would require the employment of a significantly different architectural approach to the design. Also, the risk of losing these more capable, more expensive multi-mission ships due to shallow water operations and proximity to coastal high-speed vessels and mines is unacceptable.

As part of their shipbuilding programs, various Allies have combat, hull, mechanical and electrical systems programs ongoing or under development that offer possible cooperative opportunities. These subsystem designs will be examined. All meaningful cooperative opportunities can be realized without a formal cooperative development program.

### **Constraints**

#### **Key Boundary Conditions**

Architecture. The ship design must employ a total ship architectural/engineering approach that optimizes life cycle cost and performance; minimizes operating conflicts; permits rapid upgrade and change in response to evolving operational requirements; allows computational and communication resources to keep technological pace with

commercial capabilities; and provides the capability to survive and fight hurt. More specifically this implies physical element modularity; functional sharing of hardware; open systems information architecture; ship-wide resource management; automation of Command, Control, Communications, and Computers (C4I), combat engineering, and navigation functions; and embedded training. The approach should promote innovative design.

**Design** – Consideration will be given to the maximum use of modular designs in the ship's infrastructure. Emerging technologies must be accounted for during the development phase. Modern, flexible information processing must be built into any new weapon system. Since communication and data systems hold the greatest potential for growth, and therefore obsolescence, their installations must be modularized as much as possible to allow for future upgrades. Use standard man-to-machine interfaces among the systems aboard. The man-to-machine interfaces should be consistent with existing user-friendly systems.

**Personnel** – The ship must be automated to a sufficient degree to realize significant manpower reductions in engineering, combat systems, ship support and Condition III watchstanding requirements. Reduced manning concepts used by NATO Navies should be reviewed to leverage advanced technologies and future advanced technology concepts in an effort to minimize shipboard manning requirements. Preventative maintenance manpower requirements must be reduced by incorporating self-analysis features in equipment designs, and by selecting materials and preservatives that minimize corrosion. A Manpower, Personnel and Training (MPT) analysis will be performed in accordance with OPNAVINST 5311.7 (HARDMAN). This analysis will recommend options to exploit the use of technology to reduce MPT requirements. Trade-offs that reduce MPT requirements will be favored during design and development. Final MPT determination will be documented and validated in a Navy Training Plan in accordance with OPNAVINST 1500.8.

**Manned and Unmanned Vehicles** – The ship will make extensive use of a variety of organic manned and unmanned aerial, surface and underwater vehicles. The organic vehicles must be fully netted to the ship in order to facilitate real time data exchange and support littoral warfare combat operations. The ship will be designed to provide modular-mission capability through easily interchangeable vehicle payloads. The ship must be capable of employing existing manned and unmanned vehicles. The ship will employ state-of-the-art mine warfare technologies and developments and will envelope emerging technologies through a spiral development process.

**War Fighting Capability** – Ship installed sensors will be reserved for self-protection and critical mission capabilities. The netted capabilities of the ship should make maximum use of sensors/weapons in other platforms of the deployed force.

**Hull Configuration** –

Use of auxiliary fuel tanks as part of the payload for increased endurance for ocean transits is acceptable.

The ship will make maximum use of open architecture systems and modular inputs.

**Signature Reduction.** Topside design should consider minimizing radar cross-section. Design consideration will be given to ship quieting, noise monitoring and controlled anti-mine signatures.



The hull and superstructure shall make maximum use of advanced materials. The draft must be shallow, 20 feet or less, in order to facilitate shallow-water and near-land excursions.

Ship configuration will allow for the rapid launch/recovery of boats and SOF craft while operating at reasonable speed. Ship configuration will also allow for smooth launching and recovery of a variety of UUV's and USV's.

The ship will have a flight deck and hangar for day, night and all weather operations and maintenance of AH-58D AHIP or similar type helicopters. The flight deck shall also be capable of operating, fueling and supporting MH-60R/S and UAV's/VTUAV's.

Propulsion and Engineering Systems – State-of-the-Art propulsion and engineering systems should be explored not only to produce high speeds, but also to take into account extended operations at low speeds.

Smart Systems – To enhance mission accomplishment and survivability, the ship should leverage the latest in smart ship systems integrated through a robust local area network. These smart systems should take into account optimal manning concepts, ship operations, crew support services, and an Integrated Command Environment type approach. Reconfigurable spaces are a desired concept to allow for this built-in flexibility.

Cost – A total of \$220M is the targeted goal for ship construction costs in the United States for one ship in FY-05 dollars. Variant assessment should employ Cost as an Independent Variable (CAIV) in order to develop the most capable ship within the cost cap assigned.

#### Operational Constraints.

The Focused Mission High Speed Combatant must remain fully functional and operational in all environments, whether conducting independent or force operations, in heavy weather or in the presence of electromagnetic, nuclear, biological and chemical contamination and/or shock effects from nuclear and conventional weapon attack.

The Focused Mission High Speed Combatant must meet the survivability requirements of Level III as defined in OPNAVINST 9070.1. Topside system components shall be decontaminable through the use of a countermeasure wash down system and portable Decontamination (DECON) methods.

The Focused Mission High Speed Combatant must be able to operate in United States, foreign, and international waters in full compliance with existing United States and international pollution control laws and regulations.

All ship and combat system elements must make use of standard subsystems and meet required development practices. The Focused Mission High Speed Combatant must be fully integrated with other United States Navy, Marine Corps, Joint and Allied forces, and other agencies (e.g., Theater Air Defense Architecture) in combined, coordinated operations. For example, linkage with standard databases from the Defense Mapping Agency (DMA) will minimize ancillary costs and promote maximum interoperability with the widest number of weapon and sensor systems. Joint goals for standardization and interoperability will be achieved to the maximum feasible extent.

The ship must be able to embark Special Operations Forces (SOF).

The ship must be able to transit through the Panama Canal (PANAMAX).

- i. Department of the Navy, “Ship Concepts Study Request for Proposals” (Washington, D.C., 2002)
- ii. Department of Defense, Quadrennial Defense Review Report (Washington, D.C.: US Government Printing Office, 2001).
- iii. Ibid.

## **B. Survey Development and Analysis**

### **Development**

#### Purpose

The purpose of the survey is to assist in determining the relative importance of each of the major parameters to the operators. The relative importance to the operators determines the importance of meeting each of the goals and is required to determine the overall measure of effectiveness of each design.

#### Development

The survey was developed by identifying the key parameters involved in the design process and quantifying the possible compromises in terms the operators were familiar with. At the highest level of design, these parameters are speed, range, and payload. For our project, the three parameters are top speed, endurance range at best speed, and combat system payload.

In order to ask meaningful questions, the survey needed to tell the operator what the trades between these three parameters involved. That is, what reduction in speed would result from carrying a given amount of additional payload or adding a given amount to the endurance range. Further, the additional payload needed to be quantified in terms the operators could use. An operator would generally not be able to make a judgement based upon 50 tons of payload, but he can certainly make the judgement when he knows what the 50 tons is in terms of missiles or guns.

The team developed two notional payloads whose weights vary by approximately 50 tons. The Team 13A Hull Type Comparison Tool was used to roughly estimate the effect of this change in payload weight on speed and endurance range. These trades were presented to the operators in the form of questions. Some questions ask the operator to make a comparison between two options. These questions are shown in Figure B-1. Other questions are open ended and ask the operator for his opinions. Those questions are shown in Figure B-2.

Team 13A Survey

This questionnaire asks you to rate the relative importance of the two capabilities to you, the operator. For each pair, is the capability on the left more or less important than the one on the right? If the two are equal in importance, select "1."

For example, consider a question normally faced when buying a family car: Do you want to have better gas mileage or more passenger space? This would show up in our survey as:

1=Equal, 2=Moderate, 3=Strong, 4=Very Strong, 5=Extreme										
	5	4	3	2	1	2	3	4	5	
Increase mpg by 5 mpg.								X		Carry 2 additional passengers.

In this case the operator indicates that the capability to carry two additional passengers is much more important than the capability to get an additional 5 mpg. The operator is trading fuel economy for passenger space.

Survey questions will refer to the Enhanced Weapon Payload as an improvement to the Basic Weapon Payload. These Payloads are defined below. These Payloads also include sensors and control equipment that are not listed.

<b>Basic Weapon Payload</b>
CIWS
Hellfire Missiles
Nulka Decoy
1 40mm Gun

<b>Enhanced Weapon Payload</b>
<b>Basic Weapon Payload</b>
1 additional 40mm Gun
RAM
Penguin missiles
6 Torpedo Tubes

Survey

The following attributes will be compared.

Attribute	Definition
Maximum Sustained Speed	Is the maximum sustained speed the vessel can make good in Sea State 5 waves (13 ft high).
Weapon Payload	Is the group of weapons permanently installed on the vessel.
Range at maximum speed	Is the range at maximum speed in nautical miles.

1=Equal, 2=Moderate, 3=Strong, 4=Very Strong, 5=Extreme										
	5	4	3	2	1	2	3	4	5	
Increase maximum sustained speed from 40 to 45 knots										Increase range from 1600 to 1900 nm
Increase maximum sustained speed from 40 to 45 knots										Carry Enhanced Weapon Payload
Increase range from 1600 to 1900 nm										Carry Enhanced Weapon Payload

Please continue to the next page.

**Figure B-1. Survey Closed Ended Questions.**

Question 1: What are the top three capabilities needed by a littoral combatant? Please list them in order of preference.

Question 2: Would you prefer  
a vessel that goes slower than 40 knots and has an operational range greater than 2000 nautical miles at maximum speed  
or  
a vessel that goes faster than 45 knots and has an operational range less than 1500 nautical miles at maximum speed?

Question 3: Is there anything else you would like to add or comment upon?

**Figure B-2. Survey Open Ended Questions.**

### Distribution

Surveys were distributed to members of the Surface Warfare Community at both the Naval War College and at Surface Warfare Officers' School. Fourteen surveys were returned with responses. Respondents ranged in rank from Captain to Lieutenant.

### Analysis of Results

#### Raw Data

The results of the survey questions were tabulated for numerical analysis. In order to assign a numerical value to each response, each possible response was given a numerical value according to Table B-1. For example, if a respondent felt that an increase in range from 1600 to 1900 nm was extremely more valuable than increasing maximum sustained speed from 40 to 45 knots, he would mark in the rightmost column for the first question. According to Table B-1, this would be converted to a numerical value of 9.

**Table B-1. Assignment of Numerical Values to Question Responses.**

Comparison Number	5	4	3	2	1	2	3	4	5
Numerical Analysis Value	1	2	3	4	5	6	7	8	9

## Screening the Raw Data

The raw data was screened using Chauvenet's Criterion. This is a method that provides a consistent basis for elimination of points that do not follow the general trends of the others.

According to J. P. Holman in Experimental Methods for Engineers,

Suppose  $n$  measurements/observations of a quantity are taken. We shall assume that  $n$  is large enough that we may expect the results to follow a gaussian error distribution. This distribution may be used to compute the probability that a given reading will deviate a certain amount from the mean. We would not expect a probability much smaller than  $1/n$  because this would be unlikely to occur in the set of  $n$  measurements. Thus, if the probability for the observed deviation of a certain point were less than  $1/n$ , a suspicious eye would be cast at that point with an idea toward eliminating it from the data. Actually, a more restrictive test is usually applied to eliminate data points. It is known as the Chauvenet's criterion and specifies that a reading may be rejected if the probability of obtaining the particular deviation from the mean is less than  $1/2n$ . Table B-2 lists values of the ratio of deviation to standard deviation for various values of  $n$  according to the criterion.<sup>1</sup>

**Table B-2. Chauvenet's Criterion for Rejecting a Reading.**

Number of readings, $n$	Ratio of maximum acceptable deviation to standard deviation, $d_{\max}/\sigma$
3	1.38
4	1.54
5	1.65
6	1.73
7	1.80
10	1.96
15	2.13
25	2.33
50	2.57
100	2.81
300	3.14
500	3.29
1,000	3.48

In applying Chauvenet's criterion to eliminate dubious data points, one first calculates the mean value and standard deviations of the individual points using all data points. The deviations of the individual points are then compared to the standard deviation and any dubious points are removed using the table shown below or direct application as shown below. For the final data presentation a new mean value and standard deviation are computed with the dubious points eliminated from the calculation. Note that Chauvenet's criterion might be applied a second and

a third time to eliminate additional points; but this practice is unacceptable, and only the first application may be used.<sup>ii</sup>

Table B-3 shows the raw data, the numerical equivalents and the analysis of the data regarding Chauvenet's Criterion. For 14 data points, the interpolated ratio of maximum acceptable deviation to standard deviation is 2.096. Based upon this value, all results were within the acceptable criteria.

**Table B-3. Screening and Analysis of Survey Results.**

Survey	Question 1				Question 2				Question 3			
	Comparison Numbers	Numerical Analysis	Dev	Dev StdDev	Comparison Numbers	Numerical Analysis	Dev	Dev StdDev	Comparison Numbers	Numerical Analysis	Dev	Dev StdDev
1	L4	2	2.143	0.774	1	5	0.857	0.309	R5	9	4.857	1.754
2	1	5	0.857	0.309	R3	7	2.857	1.032	R4	8	3.857	1.393
3	L4	2	2.143	0.774	1	5	0.857	0.309	R4	8	3.857	1.393
4	R2	6	1.857	0.671	L5	1	3.143	1.135	L5	1	3.143	1.135
5	L4	2	2.143	0.774	R4	8	3.857	1.393	R4	8	3.857	1.393
6	L4	2	2.143	0.774	R4	8	3.857	1.393	R4	8	3.857	1.393
7	L5	1	3.143	1.135	R4	8	3.857	1.393	R4	8	3.857	1.393
8	R2	6	1.857	0.671	R4	8	3.857	1.393	R4	8	3.857	1.393
9	L4	2	2.143	0.774	L4	2	2.143	0.774	L3	3	1.143	0.413
10	R4	8	3.857	1.393	1	5	0.857	0.309	L4	2	2.143	0.774
11	L4	2	2.143	0.774	R2	6	1.857	0.671	R5	9	4.857	1.754
12	L3	3	1.143	0.413	R3	7	2.857	1.032	R3	7	2.857	1.032
13	R4	8	3.857	1.393	L3	3	1.143	0.413	R4	8	3.857	1.393
14	R5	9	4.857	1.754	R3	7	2.857	1.032	R3	7	2.857	1.032
Average		4.14				5.71				6.71		
Std Dev		2.77				2.33				2.64		

### Eigenvalue Analysis

Once the data was screened, The relative rankings were extracted using eigenvalue analysis. The average values for each comparison were inserted into an analysis routine in MathCAD. The MathCAD spreadsheet is shown as Figure B-3. The parameters are represented by the Desirability matrix. The eigenvector associated with the largest eigenvalue is calculated and normalized to calculate the weightings.

### Final Results

Table B-4 contains the final results of the survey.

**Table B-4. The Final Results of the Survey.**

Measure of Performance	Weight
Payload	0.381
Speed	0.337
Range	0.282

## Team 13A Calculation of Weightings using AHP

Ref: LCDR C. A. Whitcomb, "Naval Ship Design Philosophy Implementation," Naval Engineers Journal, January 1998.

$\text{Desireability} = \begin{pmatrix} 1 & \frac{4.14}{5} & \frac{5}{6.71} \\ \frac{5}{4.14} & 1 & \frac{5}{5.71} \\ \frac{6.71}{5} & \frac{5.71}{5} & 1 \end{pmatrix}$	R	S	P	
$\text{Desireability} = \begin{pmatrix} 1 & 0.828 & 0.745 \\ 1.208 & 1 & 0.876 \\ 1.342 & 1.142 & 1 \end{pmatrix}$	Desireabilities based on surveys.			
Eigenvalues = eigenval(Desireability)	$\text{Eigenvalues} = \begin{pmatrix} 3 \\ -4.159 \times 10^{-5} + 0.016i \\ -4.159 \times 10^{-5} - 0.016i \end{pmatrix}$			
Weightings = eigenve(DesireabilityEigenvalues)	$\text{Weightings} = \begin{pmatrix} 0.484 \\ 0.579 \\ 0.656 \end{pmatrix}$			
Normalizer = $\sum$ Weightings		Normalizer = 1.719		
$VN := \frac{\text{Weightings}}{\text{Normalizer}}$	$VN = \begin{pmatrix} 0.282 \\ 0.337 \\ 0.381 \end{pmatrix}$			
CHECK := $\sum$ VN		CHECK = 1		

**Figure B-3. Calculation of the Relative Importance of Parameters Using the Analytical Hierarchy Process.**

<sup>i</sup>. Holman, J.P., Experimental Methods for Engineers, McGraw-Hill, Inc., Boston, 2001, p. 78-79.

<sup>ii</sup>. Ibid.



# C. Arrangements

Table C-1. Compartment Areas and Volumes

COMPARTMENT	AREA						VOLUME			VOLUME CENTER			
	ASSET				Allocated	Difference	ASSET	Allocated	Difference	X	Y	Z	
NO.	M2	X	Y	Z			M3						
=====	=====	=====	=====	=====			=====			=====	=====	=====	
01-1-0	59.2	68.32	0	10.09	59.2258	-0.025799	178		178	68.32	0	11.56	
01-2-0	45.2	74.1	0	10.09	45.2144	-0.014448	135		135	74.1	0	11.56	
01-3-0	45.2	79.1	0	10.09	45.1937	0.0063148	135		135	79.1	0	11.56	
01-4-0	45.2	84.1	0	10.09	45.0578	0.1421996	135		135	84.1	0	11.56	
01-5-0	45.2	89.1	0	10.09	45.089	0.1110386	135		135	89.1	0	11.56	
01-6-0	45.2	94.1	0	10.09	43.9502	1.2497516	135		135	94.1	0	11.56	
01-7-0	45.2	99.1	0	10.09	45.1935	0.0065314	135		135	99.1	0	11.56	
01-8-0	44.8	104.08	0	10.09	44.8083	-0.008266	134		134	104.08	0	11.56	
Hangar	327.2	116.18	0	10.09	320.988	6.211991	981		981	116.18	0	12.97	
02-1-0	48.1	68.58	0	13.09	48.0838	0.0161787	144		144	68.58	0	14.56	
02-2-0	39.9	74.1	0	13.09	39.9144	-0.014448	120		120	74.1	0	14.56	
02-3-0	39.9	79.1	0	13.09	39.9	0	120		120	79.1	0	14.56	
02-4-0	39.9	84.1	0	13.09	39.88	0.02	120		120	84.1	0	14.56	
02-5-0	39.9	89.1	0	13.09	39.5	0.4	120		120	89.1	0	14.56	
02-6-0	39.9	94.1	0	13.09	39.8708	0.0292236	120		120	94.1	0	14.56	
02-7-0	39.9	99.1	0	13.09	39.9161	-0.016064	120		120	99.1	0	14.56	
02-8-0	39.5	104.08	0	13.09	38.5857	0.9143097	119		119	104.08	0	14.56	
03-1-0	38.2	68.84	0	16.09	38.1891	0.0108899	112		112	68.84	0	17.55	
2- FPK-0	11.5	4	0	7	11.5	0	46		46	3.4	0	8.7	
2- 7-0	33.4	13	0	7	33.4172	-0.017221	106		106	13	0	8.6	
2- 18-0	52.6	23	0	7	52.5681	0.031881	159		159	23	0	8.6	
2- 28-0	69.2	33.1	0	7	69.1675	0.0325134	206		206	33.1	0	8.6	
2- 38-0	83.2	43.3	0	7	83.1226	0.077424	247		247	43.3	0	8.5	
2- 48-0	103	53.9	0	7	102.992	0.0076024	305		305	53.9	0	8.5	
2- 59-0	193.7	68.9	0	7	193.701	-0.001064	570		570	68.9	0	8.5	
2- 78-0	122.4	83.7	0	7	122.415	-0.015139	358		358	83.7	0	8.5	
2- 89-0	125.5	94.7	0	7	125.468	0.0315351	366		366	94.7	0	8.5	
2- 100-0	213.1	109.6	0	7	213.107	-0.00721	620		620	109.6	0	8.5	
2- 119-0	107.4	123.8	0	7	107.404	-0.003657	312		312	123.8	0	8.5	
2- 129-0	103	133.4	0	7	103	0	300		300	133.5	0	8.5	
2- 138-0	97.6	143.1	0	7	97.6	0	284		284	143.1	0	8.5	
3- 7-0	27.1	13.2	0	4.1	27.1	0	90		90	13.1	0	5.6	
3- 18-0	48.5	23.1	0	4.1	48.48	0.02	150		150	23	0	5.6	
3- 28-0	65.9	33.2	0	4.1	65.88	0.02	201		201	33.1	0	5.6	
3- 38-0	81	43.3	0	4.1	81.0482	-0.048249	243		243	43.3	0	5.6	
3- 78-0	123.6	83.7	0	4.1	123.587	0.0127749	363		363	83.7	0	5.6	
3- 119-0	110.2	123.8	0	4.1	109.907	0.293055	321		321	123.8	0	5.6	
3- 129-0	105.7	133.4	0	4.1	105.654	0.0455168	308		308	133.4	0	5.6	
3- 138-0	98.9	143.1	0	4.1	98.9	0	291		291	143.1	0	5.6	
4- FPK-0	0	0	0	0	0	0	28	0	28	4.7	0	5.4	
4- 7-0	4.4	14.5	0	1.2	50	-45.6	50		50	13.5	0	3	
4- 18-0	15.1	23.2	0	1.2	15.08	0.02	103		103	23.1	0	2.9	
4- 28-0	22.9	33.3	0	1.2	22.88	0.02	147		147	33.2	0	2.9	
4- 38-0	35.5	43.5	0	1.2	35.5	0	192		192	43.4	0	2.8	
4- 78-0	80.2	83.6	0	1.2	322.968	-242.7682	323		323	83.7	0	2.7	
4- 119-0	0	0	0	0	0	0	227	221.4	5.6	123.7	0	3	
4- 129-0	0	0	0	0	197	-197	197		197	0	133.2	0	3.1
4- 138-0	0	0	0	0	98.9	-98.9	120	98.9	21.1	142.9	0	3.5	
HB- 7-0							1	1	0	15.3	0	1	
HB- 18-0							5	5	0	23.3	0	1	
HB- 28-0							9	9	0	33.5	0	0.9	
HB- 38-0							17	17	0	43.7	0	0.9	
HB- 48-0							31	31	0	54.3	0	0.8	
HB- 59-0							79	79	0	69.2	0	0.8	
HB- 78-0							50	50	0	83.5	0	0.8	
HB- 89-0							36	36	0	94.2	0	0.9	
HB- 100-0							19	19	0	105.6	0	1	
AMR1		43.3	0	4.1			555		555	43.3	0	4.1	
MMR1		53.9	0	4.1			1073		1073	53.9	0	4.1	
AMR2		94.7	0	4.1			702		702	94.7	0	4.1	
MMR2		109.6	0	4.1			1161		1161	109.6	0	4.1	
		FWD	DECK	OUTER			LGTH		LGTH	HT	HT	MR	
MR		BHD	ID	BHD ID			AVL		RQD	AVL	RQD	VOL	
NO.	TYPE	ID	UPR/LW	P/S			M		M	M	M	M3	
==	====	====	=====	=====			=====		=====	=====	=====	=====	

**Table C-2. Area Requirements and Allocation**

SSCS ID	Description	Deckhouse Area			Anywhere Area		
		Reqd	Allocated	Difference	Reqd	Allocated	Difference
SSCS 1.	MISSION SUPPORT	691.3	691.3	0.0	353.1	353.1	0.0
SSCS 1.1	COMMAND,COMMUNICATION+SURV	66.2	66.2	0.0	280.3	280.3	0.0
SSCS 1.11	EXTERIOR COMMUNICATIONS	5.9	5.9	0.0	65.8	65.8	0.0
SSCS 1.111	RADIO	0.0		0.0	65.8	65.8	0.0
SSCS 1.112	UNDERWATER SYSTEMS	0.0		0.0	0.0		0.0
SSCS 1.113	VISUAL COM	5.9	5.9	0.0	0.0		0.0
SSCS 1.12	SURVEILLANCE SYS	0.0		0.0	99.8	99.8	0.0
SSCS 1.121	SURFACE SURV (RADAR)	0.0		0.0	99.8	99.8	0.0
SSCS 1.122	UNDERWATER SURV (SONAR)	0.0		0.0	0.0		0.0
SSCS 1.13	COMMAND+CONTROL	33.6	33.6	0.0	100.3	100.3	0.0
SSCS 1.131	COMBAT INFO CENTER	0.0		0.0	100.3	100.3	0.0
SSCS 1.132	CONNING STATIONS	33.6	33.6	0.0	0.0		0.0
SSCS 1.13201	PILOT HOUSE	26.7	26.7	0.0	0.0		0.0
SSCS 1.13202	CHART ROOM	6.9	6.9	0.0	0.0		0.0
SSCS 1.14	COUNTERMEASURES	0.0		0.0	11.5	11.5	0.0
SSCS 1.141	ELECTRONIC	0.0		0.0	0.0		0.0
SSCS 1.142	TORPEDO	0.0		0.0	11.5	11.5	0.0
SSCS 1.143	MISSILE	0.0		0.0	0.0		0.0
SSCS 1.15	INTERIOR COMMUNICATIONS	26.7	26.7	0.0	0.0		0.0
SSCS 1.16	ENVIRONMENTAL CNTL SUP SYS	0.0		0.0	2.9	2.9	0.0
SSCS 1.2	WEAPONS	237.9	237.9	0.0	1.0	1.0	0.0
SSCS 1.2 S	WEAPONS SUPPLEMENT	17.8	17.8	0.0	0.0		0.0
SSCS 1.21	GUNS	96.8	96.8	0.0	0.0		0.0
SSCS 1.211	BATTERIES	0.0		0.0	0.0		0.0
SSCS 1.212	FIRE CONTROL	0.0		0.0	0.0		0.0
SSCS 1.213	AMMUNITION HANDLING	0.0		0.0	0.0		0.0
SSCS 1.214	AMMUNITION STOWAGE	0.0		0.0	0.0		0.0
SSCS 1.216	MAINTENANCE	0.0		0.0	0.0		0.0
SSCS 1.22	MISSILES	89.1	89.1	0.0	0.0		0.0
SSCS 1.221	LAUNCHERS	0.0		0.0	0.0		0.0
SSCS 1.222	FIRE CONTROL	0.0		0.0	0.0		0.0
SSCS 1.223	HANDLING	0.0		0.0	0.0		0.0
SSCS 1.224	MAGAZINE	0.0		0.0	0.0		0.0
SSCS 1.227	SECURITY STATION	0.0		0.0	0.0		0.0
SSCS 1.23	ROCKETS	0.0		0.0	0.0		0.0
SSCS 1.231	LAUNCHERS	0.0		0.0	0.0		0.0
SSCS 1.232	FIRE CONTROL	0.0		0.0	0.0		0.0
SSCS 1.233	HANDLING	0.0		0.0	0.0		0.0
SSCS 1.234	MAGAZINE	0.0		0.0	0.0		0.0
SSCS 1.24	TORPEDOS	34.2	34.2	0.0	0.0		0.0
SSCS 1.241	LAUNCHERS	0.0		0.0	0.0		0.0
SSCS 1.242	CONTROL	0.0		0.0	0.0		0.0
SSCS 1.243	HANDLING	0.0		0.0	0.0		0.0
SSCS 1.244	MAGAZINE	0.0		0.0	0.0		0.0
SSCS 1.25	DEPTH CHARGES	0.0		0.0	0.0		0.0
SSCS 1.251	LAUNCHERS	0.0		0.0	0.0		0.0
SSCS 1.252	CONTROL	0.0		0.0	0.0		0.0
SSCS 1.253	HANDLING	0.0		0.0	0.0		0.0
SSCS 1.254	MAGAZINE	0.0		0.0	0.0		0.0
SSCS 1.26	MINES	0.0		0.0	0.0		0.0
SSCS 1.261	LAUNCHERS	0.0		0.0	0.0		0.0
SSCS 1.262	CONTROL	0.0		0.0	0.0		0.0
SSCS 1.263	HANDLING	0.0		0.0	0.0		0.0
SSCS 1.264	MAGAZINE	0.0		0.0	0.0		0.0
SSCS 1.27	MULT EJECT RACK STOW	0.0		0.0	0.0		0.0
SSCS 1.28	WEAP MODULE STA & SERV INTER	0.0		0.0	0.0		0.0
SSCS 1.3	AVIATION	387.2	387.3	0.0	50.2	50.2	0.0
SSCS 1.31	AVIATION LAUNCH+RECOVERY	0.0	0.0	0.0	16.3	16.3	0.0
SSCS 1.311	LAUNCHING+RECOVERY AREAS	0.0		0.0	0.0		0.0
SSCS 1.31102	HELICOPTER LANDING AREA	0.0		0.0	0.0		0.0
SSCS 1.312	LAUNCHING+RECOVERY EQUIP	0.0		0.0	16.3	16.3	0.0
SSCS 1.3123	HELICOPTER RECOVERY	0.0		0.0	0.0		0.0
SSCS 1.32	AVIATION CONTROL	23.5	23.5	0.0	0.0		0.0
SSCS 1.321	FLIGHT CONTROL	12.4	12.4	0.0	0.0		0.0
SSCS 1.321S	Flight Control	3.1	3.1	0.0	0.0		0.0
SSCS 1.3212	HELO FLIGHT CONTROL	9.3	9.3	0.0	0.0		0.0
SSCS 1.321201	HELICOPTER CONTROL STATION	9.3	9.3	0.0	0.0		0.0
SSCS 1.322	NAVIGATION	11.1	11.1	0.0	0.0		0.0
SSCS 1.32202	TACAN EQUIP RM	11.1	11.1	0.0	0.0		0.0
SSCS 1.323	OPERATIONS	0.0		0.0	0.0		0.0

SSCS 1.33	AVIATION HANDLING	0.0		0.0	0.0		0.0
SSCS 1.34	AIRCRAFT STOWAGE	316.4	316.4	0.0	0.0		0.0
SSCS 1.34002	HELICOPTER HANGAR	0.0		0.0	0.0		0.0
SSCS 1.35	AVIATION ADMINISTRATION	8.4	8.4	0.0	0.0		0.0
SSCS 1.353	AIR WING	8.4	8.4	0.0	0.0		0.0
SSCS 1.35306	AVIATION OFFICE	8.4	8.4	0.0	0.0		0.0
SSCS 1.36	AVIATION MAINTENANCE	17.6	17.6	0.0	18.0	18.0	0.0
SSCS 1.361	AIRFRAME SHOPS	5.9	5.9	0.0	0.0		0.0
SSCS 1.36106	BATTERY SHOP	5.9	5.9	0.0	0.0		0.0
SSCS 1.369	ORGANIZATIONAL LEVEL MAINTANENCE	11.6	11.6	0.0	0.0		0.0
SSCS 1.36905	HELICOPTER SHOP	11.6	11.6	0.0	0.0		0.0
SSCS 1.37	AIRCRAFT ORDINANCE	0.0		0.0	0.0		0.0
SSCS 1.372	CONTROL	0.0		0.0	0.0		0.0
SSCS 1.373	HANDLING	0.0		0.0	0.0		0.0
SSCS 1.374	STOWAGE	0.0		0.0	0.0		0.0
SSCS 1.38	AVIATION FUEL SYS	0.0		0.0	0.0		0.0
SSCS 1.381	JP-5 SYSTEM	0.0		0.0	0.0		0.0
SSCS 1.3811	JP-5 TRANSFER	0.0		0.0	0.0		0.0
SSCS 1.3812	JP-5 HANDLING	0.0		0.0	0.0		0.0
SSCS 1.3813	AVIATION FUEL	0.0		0.0	0.0		0.0
SSCS 1.39	AVIATION STORES	21.4	21.4	0.0	15.9	15.9	0.0
SSCS 1.391	AVIATION CONSUMABLES	21.4	21.4	0.0	0.0		0.0
SSCS 1.3911	SD STOREROOM	21.4	21.4	0.0	0.0		0.0
SSCS 1.391102	AVIATION STORE RM	21.4	21.4	0.0	0.0		0.0
SSCS 1.5	CARGO	0.0		0.0	0.0		0.0
SSCS 1.6	INTERMEDIATE MAINT FAC	0.0		0.0	0.0		0.0
SSCS 1.7	FLAG FACILITIES	0.0		0.0	0.0		0.0
SSCS 1.71	OPERATIONS	0.0		0.0	0.0		0.0
SSCS 1.72	CONTROL	0.0		0.0	0.0		0.0
SSCS 1.73	HANDLING	0.0		0.0	0.0		0.0
SSCS 1.74	STOWAGE	0.0		0.0	0.0		0.0
SSCS 1.75	ADMIN	0.0		0.0	0.0		0.0
SSCS 1.8	SPECIAL MISSIONS	0.0		0.0	0.0		0.0
SSCS 1.9	SM ARMS,PYRO+SALU BAT	0.0		0.0	21.6	21.6	0.0
SSCS 1.9 S	SM ARMS SUPPLEMENT	0.0		0.0	14.3	14.3	0.0
SSCS 1.91	SM ARMS (LOCKER)	0.0		0.0	6.0	6.0	0.0
SSCS 1.91001	SM ARMS LOCKER	0.0		0.0	6.0	6.0	0.0
SSCS 1.92	PYROTECHNICS	0.0		0.0	0.0		0.0
SSCS 1.93	SALUTING BAT (MAGAZINE)	0.0		0.0	0.0		0.0
SSCS 1.94	ARMORY	0.0		0.0	1.3	1.3	0.0
SSCS 1.95	SECURITY FORCE EQUIP	0.0		0.0	0.0		0.0
SSCS 2.	HUMAN SUPPORT	28.7	28.7	0.0	330.5	330.6	0.0
SSCS 2.1	LIVING	27.4	27.4	0.0	209.6	209.6	0.0
SSCS 2.11	OFFICER LIVING	25.1	25.1	0.0	49.1	49.1	0.0
SSCS 2.111	BERTHING	20.4	20.4	0.0	43.2	43.2	0.0
SSCS 2.1111	SHIP OFFICER	20.4	20.4	0.0	43.2	43.2	0.0
SSCS 2.111104	COMMANDING OFFICER STATEROOM	20.4	20.4	0.0	0.0		0.0
SSCS 2.111123	DEPARTMENT HEAD STATEROOM	0.0		0.0	11.1	11.1	0.0
SSCS 2.1111302	OFFICER STATEROOM (DBL)	0.0		0.0	32.1	32.1	0.0
SSCS 2.1114	AVIATION OFFICER	0.0		0.0	0.0		0.0
SSCS 2.1115	FLAG OFFICER	0.0		0.0	0.0		0.0
SSCS 2.1116	TRANSIENT OFFICER	0.0		0.0	0.0		0.0
SSCS 2.1117	SPECIAL MISSION OFFICER	0.0		0.0	0.0		0.0
SSCS 2.112	SANITARY	4.6	4.6	0.0	5.9	5.9	0.0
SSCS 2.1121	SHIP OFFICER	4.6	4.6	0.0	5.9	5.9	0.0
SSCS 2.1121101	COMMANDING OFFICER BATH	4.6	4.6	0.0	0.0		0.0
SSCS 2.1121203	OFFICER BATH	0.0		0.0	0.0		0.0
SSCS 2.1121303	OFFICER WR, WC & SH	0.0		0.0	5.9	5.9	0.0
SSCS 2.1124	AVIATION OFFICER	0.0		0.0	0.0		0.0
SSCS 2.1125	FLAG OFFICER	0.0		0.0	0.0		0.0
SSCS 2.1126	TRANSIENT OFFICER	0.0		0.0	0.0		0.0
SSCS 2.1127	SPECIAL MISSION OFFICER	0.0		0.0	0.0		0.0
SSCS 2.12	CPO LIVING	0.0		0.0	16.1	16.1	0.0
SSCS 2.121	BERTHING	0.0		0.0	10.2	10.2	0.0
SSCS 2.1211	SHIP CPO	0.0		0.0	10.2	10.2	0.0
SSCS 2.121101	LIVING SPACE	0.0		0.0	10.2	10.2	0.0
SSCS 2.1212	MARINE MASTER SGT	0.0		0.0	0.0		0.0
SSCS 2.1213	SENIOR TROOP NCO	0.0		0.0	0.0		0.0
SSCS 2.1215	FLAG CPO	0.0		0.0	0.0		0.0
SSCS 2.1217	SPECIAL MISSION CPO	0.0		0.0	0.0		0.0
SSCS 2.122	SANITARY	0.0		0.0	5.9	5.9	0.0
SSCS 2.1221	SHIP CPO	0.0		0.0	5.9	5.9	0.0
SSCS 2.122101	SANITARY	0.0		0.0	5.9	5.9	0.0

SSCS 2.1222	MARINE MASTER SGT	0.0		0.0	0.0		0.0
SSCS 2.1223	SENIOR TROOP NCO	0.0		0.0	0.0		0.0
SSCS 2.1225	FLAG CPO	0.0		0.0	0.0		0.0
SSCS 2.1227	SPECIAL MISSION CPO	0.0		0.0	0.0		0.0
SSCS 2.13	CREW LIVING	0.0		0.0	132.6	132.6	0.0
SSCS 2.131	BERTHING	0.0		0.0	108.7	108.7	0.0
SSCS 2.1311	SHIP CREW	0.0		0.0	108.7	108.7	0.0
SSCS 2.131101	LIVING SPACE	0.0		0.0	108.7	108.7	0.0
SSCS 2.1312	MARINE	0.0		0.0	0.0		0.0
SSCS 2.1313	TROOP	0.0		0.0	0.0		0.0
SSCS 2.1315	FLAG CREW	0.0		0.0	0.0		0.0
SSCS 2.1317	SPECIAL MISSION CREW	0.0		0.0	0.0		0.0
SSCS 2.132	SANITARY	0.0		0.0	23.9	23.9	0.0
SSCS 2.1321	SHIP CREW	0.0		0.0	23.9	23.9	0.0
SSCS 2.132101	SANITARY	0.0		0.0	23.9	23.9	0.0
SSCS 2.1322	MARINE	0.0		0.0	0.0		0.0
SSCS 2.1323	TROOP	0.0		0.0	0.0		0.0
SSCS 2.1325	FLAG CREW	0.0		0.0	0.0		0.0
SSCS 2.1327	SPECIAL MISSION CREW	0.0		0.0	0.0		0.0
SSCS 2.133	RECREATION	0.0		0.0	0.0		0.0
SSCS 2.13306	CREW LOUNGE	0.0		0.0	0.0		0.0
SSCS 2.14	GENERAL SANITARY FACILITIES	2.3	2.3	0.0	4.6	4.6	0.0
SSCS 2.14002	BRIDGE WASHRM & WC	2.3	2.3	0.0	0.0		0.0
SSCS 2.14003	DECK WASHRM & WC	0.0		0.0	2.3	2.3	0.0
SSCS 2.14004	ENGINEERING WR & WC	0.0		0.0	2.3	2.3	0.0
SSCS 2.15	SHIP RECREATION FAC	0.0		0.0	4.0	4.0	0.0
SSCS 2.151	MUSIC	0.0		0.0	1.3	1.3	0.0
SSCS 2.15101	ENTERTAINMENT EQUIP STRM	0.0		0.0	1.3	1.3	0.0
SSCS 2.152	MOTION PIC FILM+EQUIP	0.0		0.0	1.9	1.9	0.0
SSCS 2.15201	PROJECTION EQUIP RM	0.0		0.0	1.9	1.9	0.0
SSCS 2.153	PHYSICAL FITNESS	0.0		0.0	0.8	0.8	0.0
SSCS 2.15302	ATHLETIC GEAR STRM	0.0		0.0	0.8	0.8	0.0
SSCS 2.154	TV ROOM	0.0		0.0	0.0		0.0
SSCS 2.16	TRAINING	0.0		0.0	3.3	3.3	0.0
SSCS 2.16002	RECOGNITION TRAINING LKR	0.0		0.0	3.3	3.3	0.0
SSCS 2.2	COMMISSARY	0.0		0.0	95.3	95.3	0.0
SSCS 2.21	FOOD SERVICE	0.0		0.0	46.8	46.8	0.0
SSCS 2.211	OFFICER	0.0		0.0	18.6	18.6	0.0
SSCS 2.21101	WARDROOM MESSRM & LOUNGE	0.0		0.0	18.6	18.6	0.0
SSCS 2.212	CPO	0.0		0.0	0.0		0.0
SSCS 2.213	CREW	0.0		0.0	28.2	28.2	0.0
SSCS 2.21303	CREW MESSROOM	0.0		0.0	28.2	28.2	0.0
SSCS 2.214	MESS MANAGEMENT SPLST	0.0		0.0	0.0		0.0
SSCS 2.21401	MESS MNGMNT SPLST MESSRM	0.0		0.0	0.0		0.0
SSCS 2.215	FLAG OFFICER	0.0		0.0	0.0		0.0
SSCS 2.22	COMMISSARY SERVICE SPACES	0.0		0.0	39.2	39.2	0.0
SSCS 2.221	FOOD PREPARATION SPACES	0.0		0.0	0.0		0.0
SSCS 2.222	GALLEY	0.0		0.0	22.5	22.5	0.0
SSCS 2.22202	WARD ROOM GALLEY	0.0		0.0	8.7	8.7	0.0
SSCS 2.22204	CREW GALLEY	0.0		0.0	13.7	13.7	0.0
SSCS 2.223	PANTRIES	0.0		0.0	7.4	7.4	0.0
SSCS 2.22302	WARDROOM PANTRY	0.0		0.0	7.4	7.4	0.0
SSCS 2.224	SCULLERY	0.0		0.0	9.3	9.3	0.0
SSCS 2.22403	CREW SCULLERY	0.0		0.0	9.3	9.3	0.0
SSCS 2.225	GARBAGE DISPOSAL	0.0		0.0	0.0		0.0
SSCS 2.226	PREPARED FOOD HANDLING	0.0		0.0	0.0		0.0
SSCS 2.23	FOOD STORAGE+ISSUE	0.0		0.0	9.3	9.3	0.0
SSCS 2.231	CHILL PROVISIONS	0.0		0.0	3.0	3.0	0.0
SSCS 2.232	FROZEN PROVISIONS	0.0		0.0	2.0	2.0	0.0
SSCS 2.233	DRY PROVISIONS	0.0		0.0	4.3	4.3	0.0
SSCS 2.234	ISSUE	0.0		0.0	0.0		0.0
SSCS 2.3	MEDICAL+DENTAL (MEDICAL)	0.0		0.0	1.4	1.4	0.0
SSCS 2.31	MEDICAL FACILITIES	0.0		0.0	0.0		0.0
SSCS 2.31034	MEDICAL LINEN LOCKER	0.0		0.0	0.0		0.0
SSCS 2.33	BATTLE DRESSING	0.0		0.0	0.0		0.0
SSCS 2.331	AUX BATTLE DRESSING	0.0		0.0	0.0		0.0
SSCS 2.34	MEDICAL & DENTAL STOWAGE	0.0		0.0	1.4	1.4	0.0
SSCS 2.341	MEDICAL	0.0		0.0	1.4	1.4	0.0
SSCS 2.34103	MEDICAL LOCKER	0.0		0.0	1.4	1.4	0.0
SSCS 2.342	DENTAL	0.0		0.0	0.0		0.0
SSCS 2.35	MEDICAL & DENTAL ADMIN	0.0		0.0	0.0		0.0
SSCS 2.352	DENTAL ADMIN	0.0		0.0	0.0		0.0

SSCS 2.4	GENERAL SERVICES	0.0		0.0	18.1	18.1	0.0
SSCS 2.41	SHIP STORE FACILITIES	0.0		0.0	6.0	6.0	0.0
SSCS 2.41001	SHIP STORE	0.0		0.0	0.0		0.0
SSCS 2.41005	VENDING MACHINE AREA	0.0		0.0	0.0		0.0
SSCS 2.41006	SHIP STORE STORERM	0.0		0.0	6.0	6.0	0.0
SSCS 2.42	LAUNDRY FACILITIES	0.0		0.0	12.1	12.1	0.0
SSCS 2.42001	LAUNDRY	0.0		0.0	12.1	12.1	0.0
SSCS 2.44	BARBER SERVICE	0.0		0.0	0.0		0.0
SSCS 2.46	POSTAL SERVICE	0.0		0.0	0.0		0.0
SSCS 2.47	BRIG	0.0		0.0	0.0		0.0
SSCS 2.48	RELIGIOUS	0.0		0.0	0.0		0.0
SSCS 2.5	PERSONNEL STORES	1.3	1.3	0.0	2.1	2.1	0.0
SSCS 2.51	BAGGAGE STOREROOMS	0.0		0.0	0.0		0.0
SSCS 2.52	MESSROOM STORES	0.7	0.7	0.0	0.0		0.0
SSCS 2.52001	WARDROOM STOREROOM	0.7	0.7	0.0	0.0		0.0
SSCS 2.55	FOUL WEATHER GEAR	0.5	0.5	0.0	0.0		0.0
SSCS 2.55001	FOUL WEATHER GEAR LOCKER	0.5	0.5	0.0	0.0		0.0
SSCS 2.56	LINEN STOWAGE	0.0		0.0	1.7	1.7	0.0
SSCS 2.57	FOLDING CHAIR STOREROOM	0.0		0.0	0.4	0.4	0.0
SSCS 2.6	CBR PROTECTION	0.0		0.0	2.2	2.2	0.0
SSCS 2.61	CBR DECON STATIONS	0.0		0.0	0.0		0.0
SSCS 2.62	CBR DEFENSE EQUIPMENT	0.0		0.0	2.2	2.2	0.0
SSCS 2.62001	CBR DEFENSE EQP STRMS	0.0		0.0	2.2	2.2	0.0
SSCS 2.63	CPS AIRLOCKS	0.0		0.0	0.0		0.0
SSCS 2.7	LIFESAVING EQUIPMENT	0.0		0.0	1.9	1.9	0.0
SSCS 2.71	LIFEJACKET LOCKER	0.0		0.0	1.9	1.9	0.0
SSCS 3.	SHIP SUPPORT	94.1	94.1	0.0	937.8	935.5	2.3
SSCS 3.1	SHIP CNTL SYS(STEERING&DIVING)	0.0		0.0	54.8	54.8	0.0
SSCS 3.11	STEERING GEAR	0.0		0.0	54.8	54.8	0.0
SSCS 3.12	ROLL STABILIZATION	0.0		0.0	0.0		0.0
SSCS 3.15	STEERING CONTROL	0.0		0.0	0.0		0.0
SSCS 3.2	DAMAGE CONTROL	0.0		0.0	105.5	105.5	0.0
SSCS 3.21	DAMAGE CNTRL CENTRAL	0.0		0.0	54.8	54.8	0.0
SSCS 3.22	REPAIR STATIONS	0.0		0.0	32.6	32.6	0.0
SSCS 3.25	FIRE FIGHTING	0.0		0.0	18.1	18.1	0.0
SSCS 3.3	SHIP ADMINISTRATION	0.0		0.0	79.4	79.4	0.0
SSCS 3.301	GENERAL SHIP	0.0		0.0	8.2	8.2	0.0
SSCS 3.302	EXECUTIVE DEPT	0.0		0.0	18.9	18.9	0.0
SSCS 3.303	ENGINEERING DEPT	0.0		0.0	11.6	11.6	0.0
SSCS 3.304	SUPPLY DEPT	0.0		0.0	29.0	29.0	0.0
SSCS 3.305	DECK DEPT	0.0		0.0	5.0	5.0	0.0
SSCS 3.306	OPERATIONS DEPT	0.0		0.0	6.7	6.7	0.0
SSCS 3.307	WEAPONS DEPT	0.0		0.0	0.0		0.0
SSCS 3.308	REACTOR DEPT	0.0		0.0	0.0		0.0
SSCS 3.309	MARINES	0.0		0.0	0.0		0.0
SSCS 3.31	SHIP PHOTO/PRINT SVCS	0.0		0.0	0.0		0.0
SSCS 3.5	DECK AUXILIARIES	15.8	15.8	0.0	23.3	23.3	0.0
SSCS 3.51	ANCHOR HANDLING	0.0		0.0	23.3	23.3	0.0
SSCS 3.52	LINE HANDLING	0.0		0.0	0.0		0.0
SSCS 3.53	TRANSFER-AT-SEA	15.8	15.8	0.0	0.0		0.0
SSCS 3.54	SHIP BOATS STOWAGE	0.0		0.0	0.0		0.0
SSCS 3.6	SHIP MAINTENANCE	0.0		0.0	103.6	103.6	0.0
SSCS 3.61	ENGINEERING DEPT	0.0		0.0	74.0	74.0	0.0
SSCS 3.611	AUX (FILTER CLEANING)	0.0		0.0	9.6	9.6	0.0
SSCS 3.612	ELECTRICAL	0.0		0.0	22.5	22.5	0.0
SSCS 3.613	MECH (GENERAL WK SHOP)	0.0		0.0	31.7	31.7	0.0
SSCS 3.614	PROPULSION MAINTENANCE	0.0		0.0	10.2	10.2	0.0
SSCS 3.62	OPERATIONS DEPT (ELECT SHOP)	0.0		0.0	13.9	13.9	0.0
SSCS 3.63	WEAPONS DEPT (ORDINANCE SHOP)	0.0		0.0	5.3	5.3	0.0
SSCS 3.64	DECK DEPT (CARPENTER SHOP)	0.0		0.0	10.4	10.4	0.0
SSCS 3.7	STOWAGE	0.0		0.0	318.0	317.9	0.0
SSCS 3.71	SUPPLY DEPT	0.0		0.0	230.6	230.6	0.0
SSCS 3.711	HAZARDOUS MATL (FLAM LIQ)	0.0		0.0	23.9	23.9	0.0
SSCS 3.712	SPECIAL CLOTHING	0.0		0.0	9.6	9.6	0.0
SSCS 3.713	GEN USE CONSUM+REPAIR PART	0.0		0.0	153.1	153.1	0.0
SSCS 3.714	SHIP STORE STORES	0.0		0.0	6.1	6.1	0.0
SSCS 3.715	STORES HANDLING	0.0		0.0	37.9	37.9	0.0
SSCS 3.72	ENGINEERING DEPT	0.0		0.0	5.0	5.0	0.0
SSCS 3.73	OPERATIONS DEPT	0.0		0.0	7.0	7.0	0.0
SSCS 3.74	DECK DEPT (BOATSWAIN STORES)	0.0		0.0	62.2	62.2	0.0
SSCS 3.75	WEAPONS DEPT	0.0		0.0	4.5	4.5	0.0
SSCS 3.76	EXEC DEPT (MASTER-AT-ARMS STOR)	0.0		0.0	5.2	5.2	0.0
SSCS 3.78	CLEANING GEAR STOWAGE	0.0		0.0	3.4	3.4	0.0

SSCS 3.8	ACCESS (INTERIOR-NORMAL)	78.3	78.3	0.0	249.0	246.7	2.3
SSCS 3.82	INTERIOR	78.3	78.3	0.0	249.0	246.7	2.3
SSCS 3.821	NORMAL ACCESS	76.3	76.3	0.0	242.0	239.7	2.3
SSCS 3.822	ESCAPE ACCESS	2.0	2.0	0.0	7.0	7.0	0.0
SSCS 3.9	TANKS	0.0		0.0	4.3	4.3	0.0
SSCS 3.91	SHIP PROP SYS TNKG	0.0		0.0	0.0		0.0
SSCS 3.911	SHIP ENDUR FUEL TNKG	0.0		0.0	0.0		0.0
SSCS 3.91101	ENDUR FUEL TANK	0.0		0.0	0.0		0.0
SSCS 3.91104	CLEAN BALLAST TANK	0.0		0.0	0.0		0.0
SSCS 3.914	FEEDWATER TNKG	0.0		0.0	0.0		0.0
SSCS 3.92	BALLAST TANK	0.0		0.0	0.0		0.0
SSCS 3.93	FRESH WATER TNKG	0.0		0.0	0.0		0.0
SSCS 3.94	POLLUTION CNTRL TNKG	0.0		0.0	4.3	4.3	0.0
SSCS 3.941	SEWAGE TANKS	0.0		0.0	1.4	1.4	0.0
SSCS 3.942	OILY WASTE TANKS	0.0		0.0	2.9	2.9	0.0
SSCS 3.95	VOIDS	0.0		0.0	0.0		0.0
SSCS 3.96	COFFERDAMS	0.0		0.0	0.0		0.0
SSCS 3.97	CROSSFLOODING DUCTS	0.0		0.0	0.0		0.0
SSCS 4.	SHIP MACHINERY SYSTEM	181.0	181.1	0.0	578.7	578.7	0.0
SSCS 4.1	PROPULSION SYSTEM	99.7	99.7	0.0	202.0	202.0	0.0
SSCS 4.13	INTERNAL COMBUSTION	23.6	23.6	0.0	64.0	64.0	0.0
SSCS 4.131	ENERGY GENERATION	0.0		0.0	0.0		0.0
SSCS 4.132	COMBUSTION AIR	3.8	3.8	0.0	1.5	1.5	0.0
SSCS 4.133	EXHAUST	19.8	19.8	0.0	12.3	12.3	0.0
SSCS 4.134	CONTROL	0.0		0.0	50.2	50.2	0.0
SSCS 4.14	GAS TURBINE	76.0	76.0	0.0	138.0	138.0	0.0
SSCS 4.141	ENERGY GENERATION	0.0		0.0	0.0		0.0
SSCS 4.142	COMBUSTION AIR	33.3	33.3	0.0	22.2	22.2	0.0
SSCS 4.143	EXHAUST	42.7	42.7	0.0	28.5	28.5	0.0
SSCS 4.144	CONTROL	0.0		0.0	87.3	87.3	0.0
SSCS 4.17	AUX PROPULSION SYSTEMS	0.0		0.0	0.0		0.0
SSCS 4.2	PROPULSOR & TRANSMISSION SYST	0.0		0.0	0.0		0.0
SSCS 4.21	SCREW PROPELLER	0.0		0.0	0.0		0.0
SSCS 4.21001	PROP SHAFT ALLEY	0.0		0.0	0.0		0.0
SSCS 4.22	CYCLOIDAL PROPELLER ROOMS	0.0		0.0	0.0		0.0
SSCS 4.23	WATERJET ROOMS	0.0		0.0	0.0		0.0
SSCS 4.24	AIR FAN ROOMS	0.0		0.0	0.0		0.0
SSCS 4.3	AUX MACHINERY	81.4	81.4	0.0	376.7	376.7	0.0
SSCS 4.31	GENERAL (AUX MACH DELTA)	0.0		0.0	225.4	225.4	0.0
SSCS 4.32	A/C & REFRIGERATION	0.0		0.0	63.2	63.2	0.0
SSCS 4.321	A/C (INCL VENT)	0.0		0.0	47.3	47.3	0.0
SSCS 4.322	REFRIGERATION	0.0		0.0	15.9	15.9	0.0
SSCS 4.33	ELECTRICAL	0.0		0.0	43.3	43.3	0.0
SSCS 4.331	POWER GENERATION	0.0		0.0	38.9	38.9	0.0
SSCS 4.3311	SHIP SERVICE PWR GEN	0.0		0.0	0.0		0.0
SSCS 4.3313	BATTERIES	0.0		0.0	0.0		0.0
SSCS 4.3314	400 HERTZ	0.0		0.0	38.9	38.9	0.0
SSCS 4.332	PWR DIST & CNTRL	0.0		0.0	0.0		0.0
SSCS 4.334	DEGAUSSING	0.0		0.0	4.4	4.4	0.0
SSCS 4.3341	DEGAUSSING ROOM	0.0		0.0	4.4	4.4	0.0
SSCS 4.34	POLLUTION CONTROL SYSTEMS	0.0		0.0	5.0	5.0	0.0
SSCS 4.341	SEWAGE	0.0		0.0	3.3	3.3	0.0
SSCS 4.342	TRASH	0.0		0.0	1.7	1.7	0.0
SSCS 4.35	MECHANICAL SYSTEMS	0.0		0.0	12.6	12.6	0.0
	Mission Spaces		18.5			196.0	
	<b>Totals</b>	995	1014	0	2200	2394	2

**Tankage Tracking**

Type	Reqd	Allocated	Difference
Aviation Fuel	59.9	59.9	0
OOV Fuel	24	24	0
Endurance Fuel	356.6	553.6	-197
Clean Ballast	50	75	-25
Freshwater	17.3	34.3	-17

SHIP TONS																																				
Item	Req Area	Allocated	Diff	Volume	Req Area	Allocated	Diff	Volume	Req Area	Allocated	Diff	Volume	Req Area	Allocated	Diff	Volume																				
<b>227-0</b>					<b>228-0</b>					<b>229-0</b>					<b>230-0</b>					<b>231-0</b>					<b>232-0</b>											
Hanger	4.6				316.4				316.4				4.3				4.1			1.3				38.2				38.2								
Pswy	4.6																																			
Ladder																																				
CPS																																				
Helo Crt																																				
PC Crt																																				
Vent																																				
Inr Stack																																				
Inr Stack																																				
Av Fuel																																				
OCV Fuel																																				
Fresh Water																																				
Sea Ballast																																				
AV Fuel	3.611	9.6																																		
OCV Fuel	3.713	9.9																																		
Fresh Water	12.2																																			
Sea Ballast																																				
<b>2128-0</b>					<b>2129-0</b>					<b>2130-0</b>					<b>2131-0</b>					<b>2132-0</b>																
Modular Mission Space	95.3																																			
Av Fuel																																				
OCV Fuel																																				
Fresh Water																																				
Sea Ballast																																				
<b>2138-0</b>					<b>2139-0</b>					<b>2140-0</b>					<b>2141-0</b>					<b>2142-0</b>					<b>2143-0</b>					<b>2144-0</b>						
Waterjet	2.3				96.8																															
Av Fuel																																				
OCV Fuel																																				
Fresh Water																																				
Sea Ballast																																				
<b>2148-0</b>					<b>2149-0</b>					<b>2150-0</b>					<b>2151-0</b>					<b>2152-0</b>																
Av Fuel																																				
OCV Fuel																																				
Fresh Water																																				
Sea Ballast																																				

Figure C-1. Allocation Chart

## **D. Ship Hydrostatics**



**Hydrostatic Information**  
**TRIMARAN 2003 -- TRIMARAN2003**

Mld. Draft (meters)		Draft above baseline measured at LCF
DISPL.MLD. (MTons-SW)		Displacement molded (Density S.W. = 1.0250 MT/m3)
DISPL.TOTAL (MTons-SW)		Total displacement in salt water (includes appendages) (Density S.W. = 1.0250 MT/m3)
DISPL.TOTAL (MTons-FW)		Total displacement in fresh water (includes appendages) (Density F.W. = 1.0000 MT/m3)
CB	(m-AP)	Center of buoyancy (includes appendages)
CB(fwd)	(m-AP)	Center of buoyancy of forebody (includes appendages)
CB(aft)	(m-AP)	Center of buoyancy of aftbody (includes appendages)
CB	(meters)	Center of buoyancy above baseline
MT	(meters)	Transverse metacentric radius = (Mld.Transverse Inertia) / (Displ.Mld.)
MT	(meters)	Transverse metacenter above baseline
ML	(meters)	Longitudinal metacentric radius
ML	(meters)	Longitudinal metacenter above baseline
pcm	(MTons)	MTons per cm immersion
MT1cm	(m-MTons)	Moment to change trim 1 cm
DT1cm	(MTons)	Change in displacement per 1 cm trim aft
CF	(m-AP)	Center of flotation
I.P. AREA	(m2)	Area of waterplane
WETTED SUR.	(m2)	Wetted surface
b		Block Coefficient = (Mld.Volume)/(LBP x Mld.Draft x Mld.Beam)
b(fwd)		Block Coefficient of forebody = (Mld.Volume fwd MS)/(0.5 x LBP x Mld.Draft x Mld.Beam)
b(aft)		Block Coefficient of aftbody = (Mld.Volume aft MS)/(0.5 x LBP x Mld.Draft x Mld.Beam)
m		Midship Section Coefficient = (Mld.Midship Section Area)/(Mld.Draft x Mld.Beam)
p		Prismatic Coefficient = (Mld.Volume)/(LBP x Mld.Midship Section Area)
wp		Waterplane Coefficient = (Mld.Waterplane Area)/(LBP x Mld.Beam)
it		Transverse Inertia Coefficient = (Mld.Waterplane Inertia)/(LBP x Mld.Beam <sup>3</sup> )/12

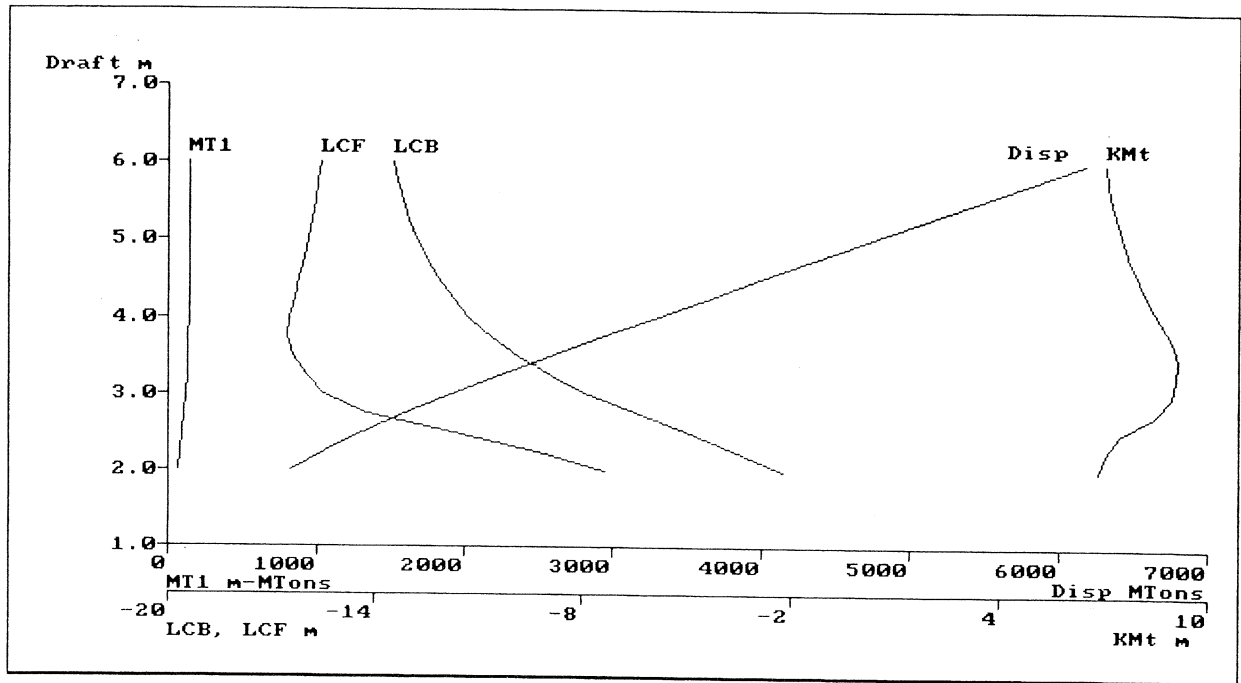
HYDROSTATIC TABLES  
 TRIMARAN2003

MLD. DRAFT (m)	DISPL. (MT-SW)	KMt (m)	LCB (m-AP)	LCF (m-AP)	MT1cm (m-MT/cm)	TPCM (MT/cm)
2.000	822	6.85	71.77F	66.64F	55.2	8.7
2.250	1,055	7.07	70.44F	64.73F	67.7	9.8
2.500	1,314	7.42	69.08F	62.25F	83.0	10.8
2.750	1,599	8.44	67.64F	59.77F	99.2	11.9
3.000	1,910	8.95	66.22F	58.45F	110.6	12.7
3.250	2,235	9.07	65.07F	57.97F	117.7	13.2
3.500	2,572	9.10	64.13F	57.58F	124.7	13.6
3.750	2,919	8.93	63.34F	57.42F	129.7	13.9
4.000	3,273	8.59	62.73F	57.50F	132.8	14.1
4.250	3,631	8.29	62.23F	57.65F	135.5	14.3
4.500	3,992	7.99	61.83F	57.78F	137.0	14.4
4.750	4,354	7.73	61.50F	57.90F	138.1	14.4
5.000	4,717	7.53	61.23F	58.02F	139.1	14.5
5.250	5,081	7.36	61.00F	58.13F	139.7	14.5
5.500	5,446	7.23	60.81F	58.23F	140.3	14.5
5.750	5,811	7.13	60.65F	58.34F	140.9	14.5
6.000	6,176	7.04	60.52F	58.45F	141.2	14.5

Assumes: Sea Water at 1.0250 MT/m3

Ship floating at even keel (no heel or trim)

CURVES of FORM  
TRIMARAN2003



HYDROSTATIC TABLES  
 TRIMARAN 2003 -- TRIMARAN2003

OLDED DRAFT	(m)	2.00	2.25	2.50	2.75	3.00	3.25	3.50	3.75	4.00	4.25
ISP.MLD.	(MTons-SW)	818	1,050	1,307	1,591	1,900	2,224	2,559	2,905	3,256	3,612
ISP.TOTAL	(MTons-SW)	822	1,055	1,314	1,599	1,910	2,235	2,572	2,919	3,273	3,631
ISP.TOTAL	(MTons-FW)	802	1,030	1,282	1,560	1,863	2,180	2,509	2,848	3,193	3,542
CB	(m-AP)	71.77F	70.44F	69.08F	67.64F	66.22F	65.07F	64.13F	63.34F	62.73F	62.23F
CB (forebody)	(m-AP)	95.35F	95.90F	96.37F	96.78F	97.15F	97.48F	97.78F	98.06F	98.32F	98.55F
CB (aftbody)	(m-AP)	52.35F	50.53F	48.72F	46.90F	45.17F	43.77F	42.63F	41.67F	40.90F	40.28F
CB	(m-CL)	0.00	0.00	0.00	0.00	0.00	0.00	0.00	0.00	0.00	0.00
B	(m)	1.37	1.54	1.70	1.87	2.03	2.19	2.34	2.50	2.65	2.79
Mt	(m)	5.48	5.53	5.72	6.57	6.92	6.88	6.76	6.43	5.95	5.50
Mt	(m)	6.85	7.07	7.42	8.44	8.95	9.07	9.10	8.93	8.59	8.29
Ml	(m)	998.85	953.85	939.22	922.69	861.21	783.41	721.20	660.70	603.40	555.23
Ml	(m)	1,000.23	955.39	940.93	924.56	863.24	785.60	723.55	663.20	606.05	558.02
PCM	(MTons)	8.7	9.8	10.8	11.9	12.7	13.2	13.6	13.9	14.1	14.3
IT1cm	(m-MTons)	55	68	83	99	111	118	125	130	133	136
DT1cm	(MTons)	0.4	0.6	0.9	1.1	1.3	1.4	1.5	1.6	1.6	1.6
CF	(m-AP)	66.64F	64.73F	62.25F	59.77F	58.45F	57.97F	57.58F	57.42F	57.50F	57.65F
P. AREA	(m2)	852	955	1,053	1,160	1,237	1,284	1,329	1,360	1,379	1,396
ETTED SUR.	(m2)	982	1,113	1,248	1,397	1,525	1,633	1,742	1,848	1,948	2,049
MAX. BEAM	(m)	9.48	10.02	19.87	20.60	21.05	21.33	21.53	21.67	21.74	21.79
ENGTH W.L.	(m)	134.56	142.68	143.32	143.97	144.61	145.25	145.89	146.54	147.18	147.82
b		0.2304	0.2630	0.2946	0.3259	0.3569	0.3855	0.4119	0.4364	0.4587	0.4789
b (forebody)		0.2081	0.2309	0.2518	0.2711	0.2891	0.3057	0.3211	0.3355	0.3486	0.3609
b (aftbody)		0.2527	0.2951	0.3375	0.3808	0.4246	0.4652	0.5027	0.5374	0.5687	0.5969
m		0.4897	0.5260	0.5579	0.5862	0.6117	0.6343	0.6555	0.6753	0.6930	0.7091
p		0.4705	0.4999	0.5281	0.5560	0.5834	0.6077	0.6284	0.6463	0.6618	0.6754
wp		0.4918	0.5518	0.6080	0.6699	0.7146	0.7416	0.7676	0.7855	0.7963	0.8061
it		0.2214	0.2867	0.3693	0.5165	0.6496	0.7551	0.8542	0.9223	0.9564	0.9815

Assumes: Sea Water at 1.0250 MT/m3  
 Fresh Water at 1.0000 MT/m3  
 Ship floating at even keel (no heel or trim)



**BONJEAN TABLES**  
**TRIMARAN 2003 -- TRIMARAN2003**

**BONJEAN TABLES -- FULL AREAS (m2)**

Mld.	#1	#2	#3	#4	#5	#6	#7	#8	#9	#10	#11	#12
DRAFT	STA 0.00	STA 0.15	STA 0.30	STA 0.45	STA 0.60	STA 0.75	STA 0.90	STA 1.00	STA 1.05	STA 1.20	STA 1.35	STA 1.50
(m)	0.00	1.11F	2.22F	3.33F	4.44F	5.55F	6.66F	7.40F	7.77F	8.88F	9.99F	11.10F
-----												
2.00	----	----	----	----	----	----	----	----	0.07	0.26	0.46	0.66
2.25	0.05	0.05	0.05	0.05	0.05	0.05	0.05	0.05	0.18	0.58	0.99	1.39
2.50	0.68	0.69	0.69	0.70	0.70	0.71	0.71	0.72	0.91	1.55	2.16	2.72
2.75	2.05	2.06	2.08	2.10	2.12	2.17	2.32	2.43	2.70	3.56	4.31	4.97
3.00	4.07	4.11	4.15	4.18	4.36	4.67	5.04	5.23	5.56	6.52	7.31	7.99
3.25	6.27	6.33	6.66	6.78	7.26	7.75	8.25	8.48	8.84	9.84	10.64	11.31
3.50	8.74	8.84	9.70	9.99	10.60	11.18	11.75	12.00	12.37	13.39	14.18	14.84
3.75	11.89	12.07	13.11	13.51	14.19	14.83	15.43	15.69	16.07	17.10	17.88	18.52
4.00	15.27	15.54	16.68	17.15	17.89	18.56	19.19	19.47	19.85	20.88	21.65	22.28
4.25	18.74	19.11	20.34	20.86	21.64	22.36	23.01	23.30	23.67	24.70	25.47	26.08
4.50	22.25	22.72	24.03	24.60	25.44	26.19	26.87	27.17	27.53	28.56	29.33	29.93
4.75	25.79	26.34	27.74	28.36	29.25	30.04	30.74	31.03	31.40	32.43	33.20	33.78
5.00	29.34	29.97	31.45	32.13	33.06	33.89	34.60	34.90	35.28	36.30	37.06	37.63
5.25	32.91	33.61	35.16	35.90	36.88	37.75	38.47	38.77	39.16	40.18	40.92	41.48
5.50	36.48	37.24	38.87	39.67	40.69	41.60	42.34	42.64	43.03	44.05	44.78	45.33
5.75	40.05	40.88	42.58	43.44	44.50	45.44	46.20	46.50	46.90	47.91	48.63	49.17
6.00	43.61	44.52	46.28	47.20	48.30	49.28	50.05	50.35	50.76	51.77	52.48	53.01
-----												

**BONJEAN TABLES -- FULL AREAS (m2)**

Mld.	#13	#14	#15	#16	#17	#18	#19	#20	#21	#22	#23	#24
DRAFT	STA 1.65	STA 1.80	STA 1.95	STA 2.00	STA 2.10	STA 2.25	STA 2.40	STA 2.55	STA 2.70	STA 2.85	STA 3.00	STA 3.00
(m)	12.21F	13.32F	14.43F	14.80F	15.54F	16.65F	17.76F	18.87F	19.98F	21.09F	22.20F	22.20F
-----												
2.00	0.85	1.05	1.25	1.31	1.35	1.40	1.45	1.51	1.56	1.62	1.67	1.67
2.25	1.80	2.20	2.60	2.73	2.81	2.92	3.02	3.13	3.24	3.35	3.46	3.46
2.50	3.28	3.82	4.36	4.54	4.64	4.78	4.94	5.09	5.25	5.42	5.57	5.57
2.75	5.58	6.14	6.69	6.87	6.93	7.06	7.21	7.38	7.53	7.72	7.91	7.91
3.00	8.57	9.08	9.57	9.73	9.72	9.78	9.88	10.01	10.10	10.24	10.45	10.45
3.25	11.86	12.32	12.73	12.86	12.79	12.75	12.78	12.83	12.84	12.88	13.08	13.08
3.50	15.36	15.76	16.11	16.21	16.08	15.94	15.87	15.82	15.72	15.63	15.79	15.79
3.75	19.02	19.36	19.64	19.71	19.53	19.29	19.12	18.94	18.72	18.48	18.57	18.57
4.00	22.74	23.04	23.26	23.30	23.06	22.73	22.45	22.15	21.78	21.39	21.37	21.37
4.25	26.52	26.77	26.93	26.95	26.65	26.23	25.84	25.42	24.91	24.34	24.19	24.19
4.50	30.33	30.53	30.64	30.64	30.28	29.77	29.28	28.73	28.07	27.34	27.03	27.03
4.75	34.15	34.30	34.36	34.34	33.92	33.33	32.72	32.04	31.25	30.36	29.88	29.87
5.00	37.97	38.08	38.09	38.04	37.57	36.88	36.17	35.36	34.43	33.37	32.74	32.72
5.25	41.79	41.86	41.82	41.75	41.23	40.44	39.62	38.69	37.62	36.40	35.61	35.56
5.50	45.61	45.63	45.54	45.45	44.87	44.00	43.08	42.01	40.80	39.42	38.47	38.40
5.75	49.42	49.40	49.26	49.14	48.52	47.55	46.52	45.33	43.99	42.45	41.34	41.23
6.00	53.23	53.16	52.97	52.83	52.15	51.09	49.96	48.65	47.16	45.47	44.21	44.05
-----												

Note: Location of stations in m-AP with Station 0 at the AP  
 Areas are for full-sections (include both sides)  
 Areas are molded (measured to the inside of bottom and shell plating)

BONJEAN TABLES (cont.)  
 TRIMARAN 2003 -- TRIMARAN2003

BONJEAN TABLES -- FULL AREAS (m2)

Mld.	#25	#26	#27	#28	#29	#30	#31	#32	#33	#34	#35	#36
DRAFT	STA 4.00	STA 5.00	STA 6.00	STA 7.00	STA 8.00	STA 9.00	STA10.00	STA11.00	STA12.00	STA13.00	STA14.00	STA15.00
(m)	29.60F	37.00F	44.40F	51.80F	59.20F	66.60F	74.00F	81.40F	88.80F	96.20F	103.60F	111.00F
2.00	3.79	6.02	8.15	9.76	11.13	11.46	11.13	10.27	8.94	7.33	5.65	4.23
2.25	5.88	8.31	10.56	12.20	13.57	13.85	13.43	12.44	10.92	9.10	7.17	5.48
2.50	8.20	10.77	13.09	14.75	16.10	16.32	15.81	14.69	13.00	10.97	8.79	6.83
2.75	10.70	13.36	15.72	17.39	18.70	18.86	18.26	17.01	15.17	12.92	10.50	8.27
3.00	13.35	16.07	18.45	20.10	21.38	21.47	20.78	19.41	17.41	14.95	12.29	9.80
3.25	16.08	18.84	21.23	22.86	24.09	24.12	23.34	21.85	19.69	17.04	14.15	11.39
3.50	18.86	21.66	24.05	25.66	26.84	26.81	25.93	24.33	22.02	19.18	16.05	13.04
3.75	21.70	24.52	26.92	28.49	29.63	29.53	28.56	26.85	24.39	21.37	18.01	14.74
4.00	24.55	27.41	29.80	31.35	32.43	32.27	31.22	29.40	26.79	23.58	20.00	16.48
4.25	27.43	30.32	32.71	34.22	35.26	35.03	33.89	31.96	29.21	25.82	22.02	18.25
4.50	30.33	33.24	35.63	37.11	38.10	37.81	36.58	34.54	31.65	28.08	24.07	20.04
4.75	33.23	36.17	38.55	40.01	40.95	40.59	39.28	37.13	34.10	30.35	26.12	21.85
5.00	36.13	39.11	41.48	42.91	43.80	43.38	41.98	39.72	36.56	32.63	28.19	23.68
5.25	39.03	42.04	44.41	45.80	46.65	46.17	44.68	42.31	39.02	34.92	30.27	25.51
5.50	41.93	44.97	47.34	48.70	49.51	48.96	47.39	44.91	41.48	37.21	32.35	27.35
5.75	44.83	47.90	50.26	51.60	52.36	51.75	50.09	47.51	43.94	39.50	34.44	29.19
6.00	47.72	50.82	53.18	54.49	55.21	54.53	52.80	50.11	46.41	41.79	36.53	31.04

BONJEAN TABLES -- FULL AREAS (m2)

Mld.	#37	#38	#39	#40	#41
DRAFT	STA16.00	STA17.00	STA18.00	STA19.00	STA20.00
(m)	118.40F	125.80F	133.20F	140.60F	148.00F
2.00	3.15	2.31	1.20	0.10	----
2.25	4.13	3.03	1.64	0.20	----
2.50	5.21	3.83	2.13	0.34	----
2.75	6.38	4.70	2.68	0.53	----
3.00	7.63	5.65	3.29	0.75	----
3.25	8.94	6.65	3.93	1.01	----
3.50	10.30	7.70	4.63	1.31	----
3.75	11.73	8.80	5.36	1.63	----
4.00	13.18	9.94	6.12	1.99	----
4.25	14.67	11.10	6.91	2.37	----
4.50	16.19	12.29	7.73	2.77	0.00
4.75	17.72	13.49	8.56	3.19	0.02
5.00	19.26	14.70	9.41	3.64	0.05
5.25	20.81	15.93	10.27	4.10	0.10
5.50	22.37	17.17	11.14	4.57	0.16
5.75	23.93	18.41	12.02	5.06	0.23
6.00	25.50	19.67	12.91	5.56	0.32

## **E. Full Load Intact Stability**



**TANK WEIGHT SUMMARY**

**Fuel Oil Tanks**

TANK NAME	WEIGHT MTons	% Full	CAPACITY MTons	VOLUME Bbls	NET VOL. Bbls	API GRAV.	TEMP. oF	DENSITY MT/m3	KG m-BL	LCG m-AP	TCG m-CL	F.S. m-MTons
M11	15	98.0	15	99	99	----	60.0	0.9500	1.00	104.50F	0.00	0
M10	30	98.0	30	197	197	----	60.0	0.9500	1.00	93.90F	0.00	0
M9	74	98.0	75	487	487	----	60.0	0.9500	1.00	79.40F	0.00	0
M8	47	98.0	48	308	308	----	60.0	0.9500	1.00	64.60F	0.00	0
M7	33	98.0	33	216	216	----	60.0	0.9500	1.00	53.60F	0.00	0
M2S	91	98.0	93	604	604	----	60.0	0.9500	3.50	15.60F	2.70S	0
M2P	91	98.0	93	604	604	----	60.0	0.9500	3.50	15.60F	2.70P	0
TOTALS	380	98.0	387	2,515	2,515				2.20	46.85F	0.00	0

**Diesel Oil Tanks**

TANK NAME	WEIGHT MTons	% Full	CAPACITY MTons	VOLUME Bbls	NET VOL. Bbls	API GRAV.	TEMP. oF	DENSITY MT/m3	KG m-BL	LCG m-AP	TCG m-CL	F.S. m-MTons
M3S	26	98.0	27	179	179	----	60.0	0.9200	3.50	26.10F	2.67S	0
M3P	26	98.0	27	179	179	----	60.0	0.9200	3.50	26.10F	2.67P	0
TOTALS	52	98.2	54	358	358				3.50	26.10F	0.00	0

**Fresh Water Tanks**

TANK NAME	WEIGHT MTons	% Full	CAPACITY MTons	VOLUME m3	DENSITY MT/m3	KG m-BL	LCG m-AP	TCG m-CL	F.S. m-MTons
M5	18	98.0	18	18	1.0000	2.00	64.60F	0.00	0
TOTALS	18	98.0	18	18		2.00	64.60F	0.00	0

**SW Ballast Tanks**

TANK NAME	WEIGHT MTons	% Full	CAPACITY MTons	VOLUME m3	DENSITY MT/m3	KG m-BL	LCG m-AP	TCG m-CL	F.S. m-MTons
M4	0	0.0	35	0	1.0250	1.00	37.00F	0.00	0
M12	0	0.0	35	0	1.0250	1.00	115.50F	0.00	0
TOTALS	0	0.0	70	0					

CARGO SUMMARY

Misc. Weights

ITEM	WEIGHT MTons	KG m-BL	LCG m-AP	TCG m-CL	F.S. m-MTons	AFT BND m-AP	FWD BND m-AP
TIPOTA	135	5.00	55.00F	0.00	0	50.00F	60.00F
TOTALS	135	5.00	55.00F	0.00	0		

**TRIM & STABILITY SUMMARY**

ITEM	WEIGHT MTons	KG m-BL	LCG m-AP	TCG m-CL	FScmom m-MTons
Light Ship	2,966	6.37	65.30F	0.00	
Constant	0	0.00	74.00F	0.00	0
Misc. Weight	135	5.00	55.00F	0.00	0
Fuel Oil	380	2.20	46.85F	0.00	0
Diesel Oil	52	3.50	26.10F	0.00	0
Fresh Water	18	2.00	64.60F	0.00	0
SW Ballast	0	0.00	74.00F	0.00	0
<b>TOTALS</b>	<b>3,551</b>	<b>5.81</b>	<b>62.35F</b>	<b>0.00</b>	<b>0</b>

**STABILITY CALCULATION**

KMt	8.31 m
KG	5.81 m
GMt	2.50 m
FSc	0.00 m
GMt Corrected	2.50 m

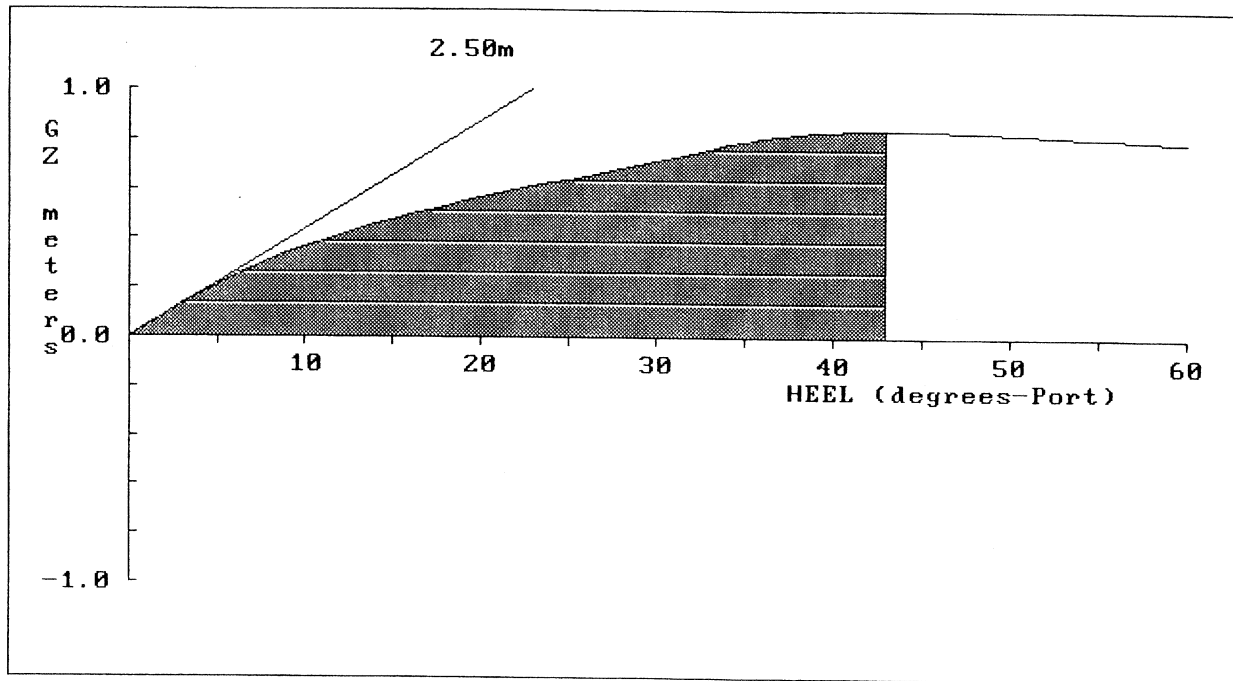
**TRIM CALCULATION**

LCF Draft	4.19 m
LCB (even keel)	62.51 m-FWD
LCF	57.75 m-FWD
MT1cm	134 m-MT/cm
Trim	0.04 m-AFT
List	0.00 deg

**DRAFTS**

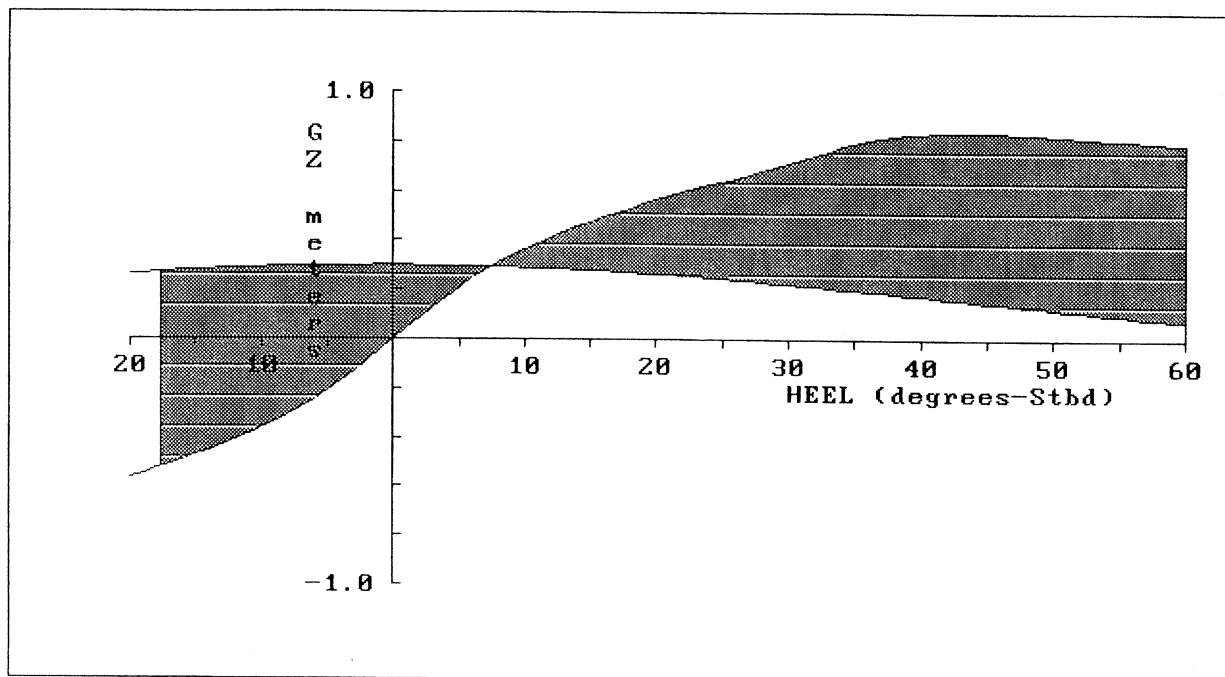
A.P.	4.21 m (13ft- 9.6in)	Aft Marks	4.20 m (13ft- 9.5in)
M.S.	4.19 m (13ft- 8.8in)	M.S.Marks	4.19 m (13ft- 8.8in)
F.P.	4.16 m (13ft- 8.0in)	Fwd Marks	4.17 m (13ft- 8.1in)

### STATICAL STABILITY



Angle of Heel	0.0 deg
Angle at Maximum GZ	43.1 deg
Area to 43.1 degrees	0.41 m-rad
Maximum GZ	0.84 m

BEAM WIND with ROLLING STABILITY EVALUATION  
 (per U.S. Navy DDS079-1)



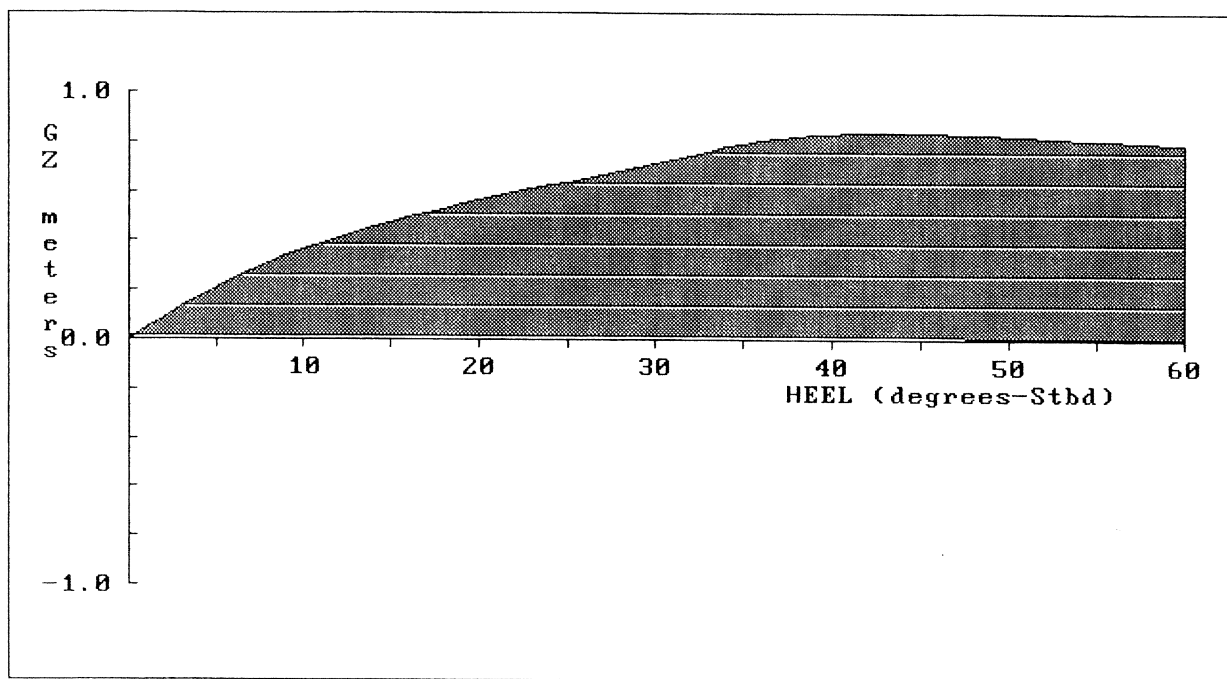
	Available	Required
Wind Heeling Arm Lw	0.29 m	
Maximum Righting Arm	0.84 m	0.49 m
Capsizing Area A2	0.2 m-rad	
Righting Area A1	0.4 m-rad	0.3 m-rad

Wind Velocity = 100 knots  
 Wind Pressure Factor = 0.0035  
 Wind Pressure = 0.1709 MT/m<sup>2</sup>  
 Projected Sail Area = 957.8 m<sup>2</sup>  
 Vertical Arm = 8.57 m ABL  
 Heeling Arm at 0 deg = 0.30 m

Wind Heel Arm Lw = 0.29 m  
 Wind Heel Angle = 7.4 deg

Mean Draft = 4.19 m  
 Displacement = 3,551 MTons  
 GMt (corrected) = 2.50 m  
 Roll Angle = 25.0 deg  
 Angle at Intercept = 60.0 deg  
 Maximum GZ = 0.84 m  
 Angle at Max. GZ = 43.1 deg

CROWDING of PERSONNEL TO ONE SIDE  
 (per U.S. Navy DDS079-1)



	Available	Required
Angle of Heel	0.4 deg	15.0 deg
Heeling Arm Lc	0.02 m	
Maximum Righting Arm	0.84 m	0.03 m
Total Righting Area	0.7 m-rad	
Reserve Righting Area	0.6 m-rad	0.3 m-rad

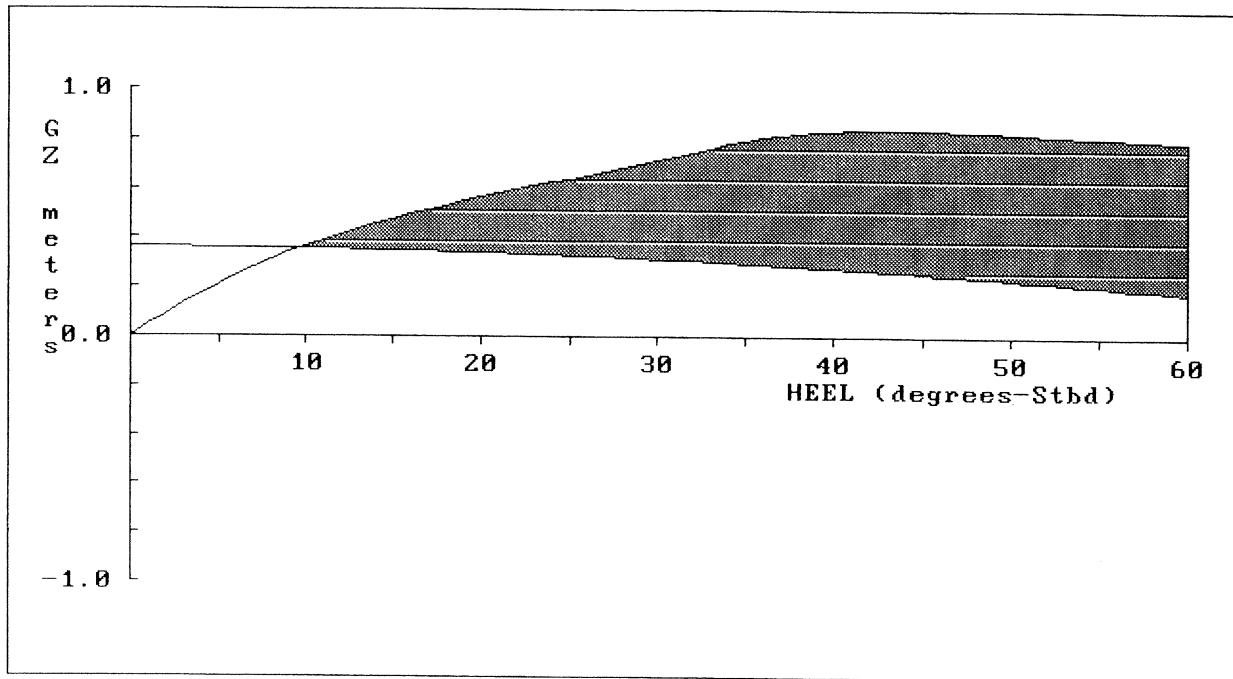
Weight of Personnel = 6 MTons  
 TCG of Personnel = 10.90 m-CL  
 Heeling Arm at 0 deg= 0.02 m

Displacement = 3,551 MTons  
 GMt (corrected) = 2.50 m

Angle at Max. GZ = 43.1 deg

Positive GZ Range = 60.0 deg  
 Angle at Intercept= 60.0 deg

**EFFECT on STABILITY of HIGH SPEED TURNING**  
 (per U.S. Navy DDS079-1)



	Available	Required
Angle of Heel	9.6 deg	15.0 deg
Heeling Arm Lc	0.36 m	
Maximum Righting Arm	0.84 m	0.59 m
Total Righting Area	0.7 m-rad	
Reserve Righting Area	0.4 m-rad	0.3 m-rad

Ship Speed in Turn = 40.0 knots  
 Turn Circle Radius = 444 m  
 Heeling Arm at 0 deg = 0.36 m

Displacement = 3,551 MTons  
 VCG = 5.81 m  
 Mean Draft = 4.19 m

Angle at Max. GZ = 43.1 deg

Positive GZ Range = 60.0 deg  
 Angle at Intercept = 60.0 deg

## **F. Minimum Load Intact Stability**



**TANK WEIGHT SUMMARY**

**Fuel Oil Tanks**

TANK NAME	WEIGHT MTons	% Full	CAPACITY MTons	VOLUME Bbls	NET VOL. Bbls	API GRAV.	TEMP. oF	DENSITY MT/m3	KG m-BL	LCG m-AP	TCG m-CL	F.S. m-MTons
M11	0	0.0	15	0	0	----	60.0	0.9500	1.00	104.50F	0.00	0
M10	0	0.0	30	0	0	----	60.0	0.9500	1.00	93.90F	0.00	0
M9	0	0.0	75	0	0	----	60.0	0.9500	1.00	79.40F	0.00	0
M8	0	0.0	48	0	0	----	60.0	0.9500	1.00	64.60F	0.00	0
M7	13	40.0	33	88	88	----	60.0	0.9500	1.00	53.60F	0.00	0
M2S	57	61.0	93	376	376	----	60.0	0.9500	3.50	15.60F	2.70S	0
M2P	57	61.0	93	376	376	----	60.0	0.9500	3.50	15.60F	2.70P	0
TOTALS	127	32.8	387	840	840				3.24	19.58F	0.00	0

**Diesel Oil Tanks**

TANK NAME	WEIGHT MTons	% Full	CAPACITY MTons	VOLUME Bbls	NET VOL. Bbls	API GRAV.	TEMP. oF	DENSITY MT/m3	KG m-BL	LCG m-AP	TCG m-CL	F.S. m-MTons
M3S	9	33.0	27	60	60	----	60.0	0.9200	3.50	26.10F	2.67S	0
M3P	9	33.0	27	60	60	----	60.0	0.9200	3.50	26.10F	2.67P	0
TOTALS	18	33.1	54	120	120				3.50	26.10F	0.00	0

**Fresh Water Tanks**

TANK NAME	WEIGHT MTons	% Full	CAPACITY MTons	VOLUME m3	DENSITY MT/m3	KG m-BL	LCG m-AP	TCG m-CL	F.S. m-MTons
M5	6	33.0	18	6	1.0000	2.00	64.60F	0.00	0
TOTALS	6	33.0	18	6		2.00	64.60F	0.00	0

**SW Ballast Tanks**

TANK NAME	WEIGHT MTons	% Full	CAPACITY MTons	VOLUME m3	DENSITY MT/m3	KG m-BL	LCG m-AP	TCG m-CL	F.S. m-MTons
M4	34	98.0	35	33	1.0250	1.00	37.00F	0.00	0
M12	25	70.0	35	24	1.0250	1.00	115.50F	0.00	0
TOTALS	59	84.4	70	57		1.00	69.71F	0.00	0

CARGO SUMMARY

Misc. Weights

ITEM	WEIGHT MTons	KG m-BL	LCG m-AP	TCG m-CL	F.S. m-MTons	AFT BND m-AP	FWD BND m-AP
TIPOTA	135	5.00	55.00F	0.00	0	50.00F	60.00F
TOTALS	135	5.00	55.00F	0.00	0		

**TRIM & STABILITY SUMMARY**

ITEM	WEIGHT MTons	KG m-BL	LCG m-AP	TCG m-CL	FScmom m-MTons
Light Ship	2,966	6.37	65.30F	0.00	
Constant	0	0.00	74.00F	0.00	0
Misc. Weight	135	5.00	55.00F	0.00	0
Fuel Oil	127	3.24	19.58F	0.00	0
Diesel Oil	18	3.50	26.10F	0.00	0
Fresh Water	6	2.00	64.60F	0.00	0
SW Ballast	59	1.00	69.71F	0.00	0
<b>TOTALS</b>	<b>3,310</b>	<b>6.08</b>	<b>63.00F</b>	<b>0.00</b>	<b>0</b>

**STABILITY CALCULATION**

KMt	8.45 m
KG	6.08 m
Gmt	2.38 m
FSc	0.00 m
Gmt Corrected	2.38 m

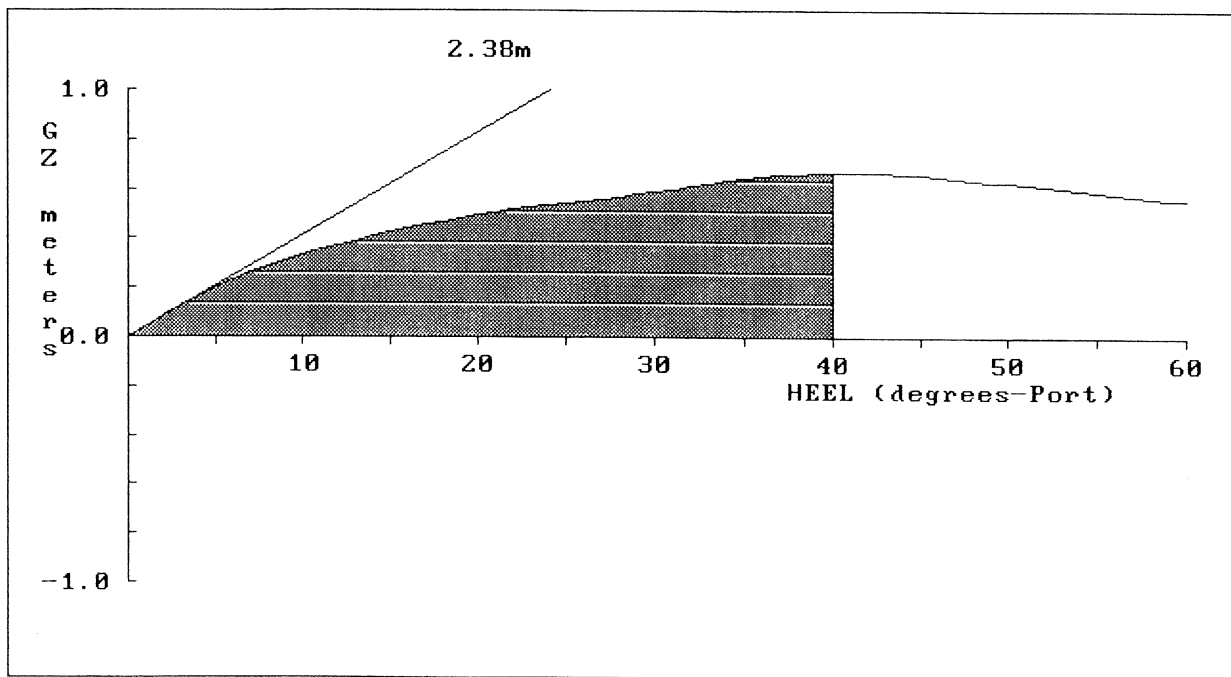
**TRIM CALCULATION**

LCF Draft	4.02 m
LCB (even keel)	62.97 m-FWD
LCF	57.79 m-FWD
MT1cm	131 m-MT/cm
Trim	0.01 m-FWD
List	0.00 deg

**DRAFTS**

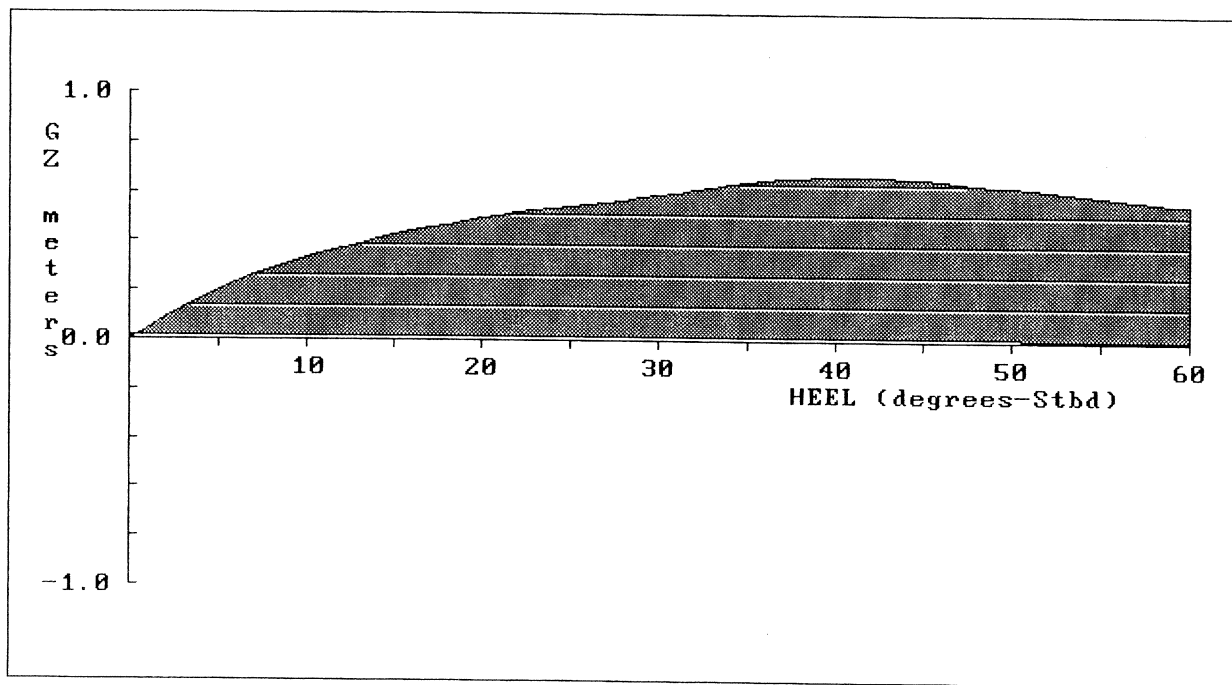
A.P.	4.02 m (13ft- 2.1in)	Aft Marks	4.02 m (13ft- 2.1in)
M.S.	4.02 m (13ft- 2.2in)	M.S.Marks	4.02 m (13ft- 2.2in)
F.P.	4.02 m (13ft- 2.4in)	Fwd Marks	4.02 m (13ft- 2.3in)

### STATICAL STABILITY



Angle of Heel	0.0 deg
Angle at Maximum GZ	40.7 deg
Area to 40.7 degrees	0.32 m-rad
Maximum GZ	0.67 m

CROWDING of PERSONNEL TO ONE SIDE  
 (per U.S. Navy DDS079-1)



	Available	Required
Angle of Heel	0.4 deg	15.0 deg
Heeling Arm Lc	0.02 m	
Maximum Righting Arm	0.67 m	0.03 m
Total Righting Area	0.5 m-rad	
Reserve Righting Area	0.5 m-rad	0.2 m-rad

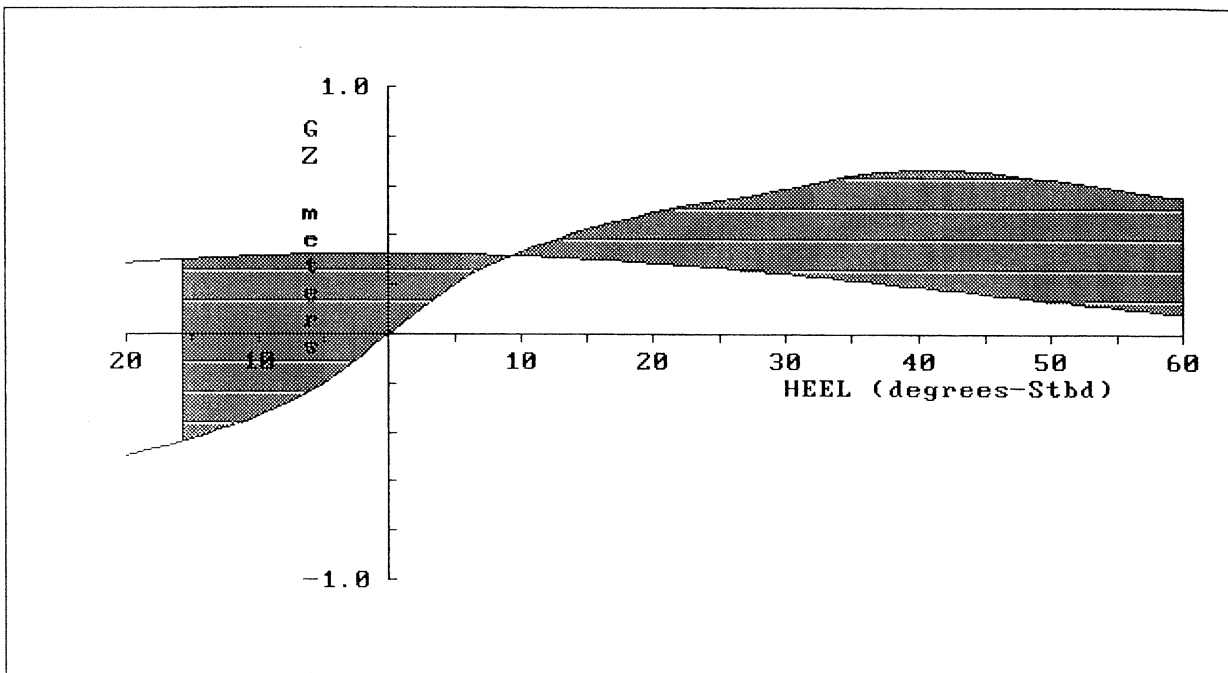
Weight of Personnel = 6 MTons  
 TCG of Personnel = 10.90 m-CL  
 Heeling Arm at 0 deg= 0.02 m

Displacement = 3,310 MTons  
 GMt (corrected) = 2.38 m

Angle at Max. GZ = 40.7 deg

Positive GZ Range = 60.0 deg  
 Angle at Intercept= 60.0 deg

BEAM WIND with ROLLING STABILITY EVALUATION  
 (per U.S. Navy DDS079-1)



	Available	Required
Wind Heeling Arm Lw	0.32 m	
Maximum Righting Arm	0.67 m	0.53 m
Capsizing Area A2	0.2 m-rad	
Righting Area A1	0.3 m-rad	0.3 m-rad

Wind Velocity = 100 knots  
 Wind Pressure Factor = 0.0035  
 Wind Pressure = 0.1709 MT/m<sup>2</sup>

Mean Draft = 4.02 m  
 Displacement = 3,310 MTons  
 GMT (corrected) = 2.38 m

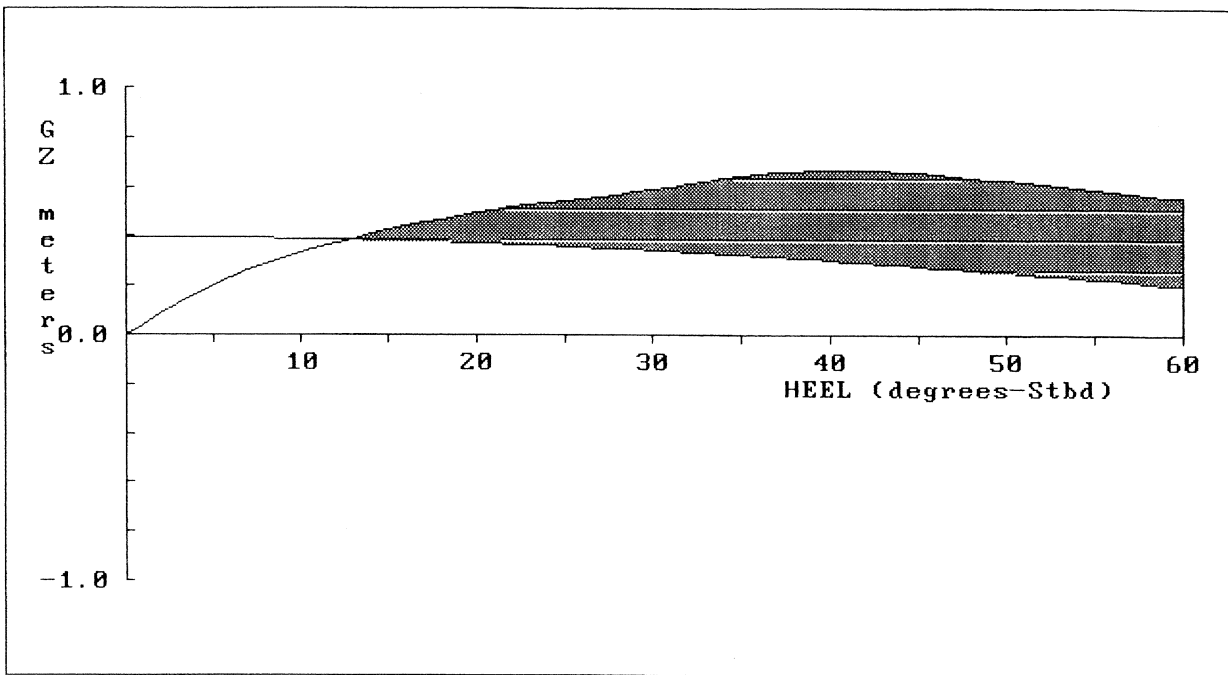
Projected Sail Area = 982.4 m<sup>2</sup>  
 Vertical Arm = 8.46 m ABL  
 Heeling Arm at 0 deg = 0.33 m

Roll Angle = 25.0 deg  
 Angle at Intercept = 60.0 deg

Wind Heel Arm Lw = 0.32 m  
 Wind Heel Angle = 9.3 deg

Maximum GZ = 0.67 m  
 Angle at Max. GZ = 40.7 deg

**EFFECT on STABILITY of HIGH SPEED TURNING**  
 (per U.S. Navy DDS079-1)



	Available	Required
Angle of Heel	12.7 deg	15.0 deg
Heeling Arm Lc	0.39 m	
Maximum Righting Arm	0.67 m	0.64 m
Total Righting Area	0.5 m-rad	
Reserve Righting Area	0.2 m-rad	0.2 m-rad

Ship Speed in Turn =	40.0 knots	Displacement =	3,310 MTons
Turn Circle Radius =	444 m	VCG =	6.08 m
Heeling Arm at 0 deg =	0.40 m	Mean Draft =	4.02 m
Angle at Max. GZ =	40.7 deg	Positive GZ Range =	60.0 deg
		Angle at Intercept =	60.0 deg

## **G. Damaged Stability Calculations**

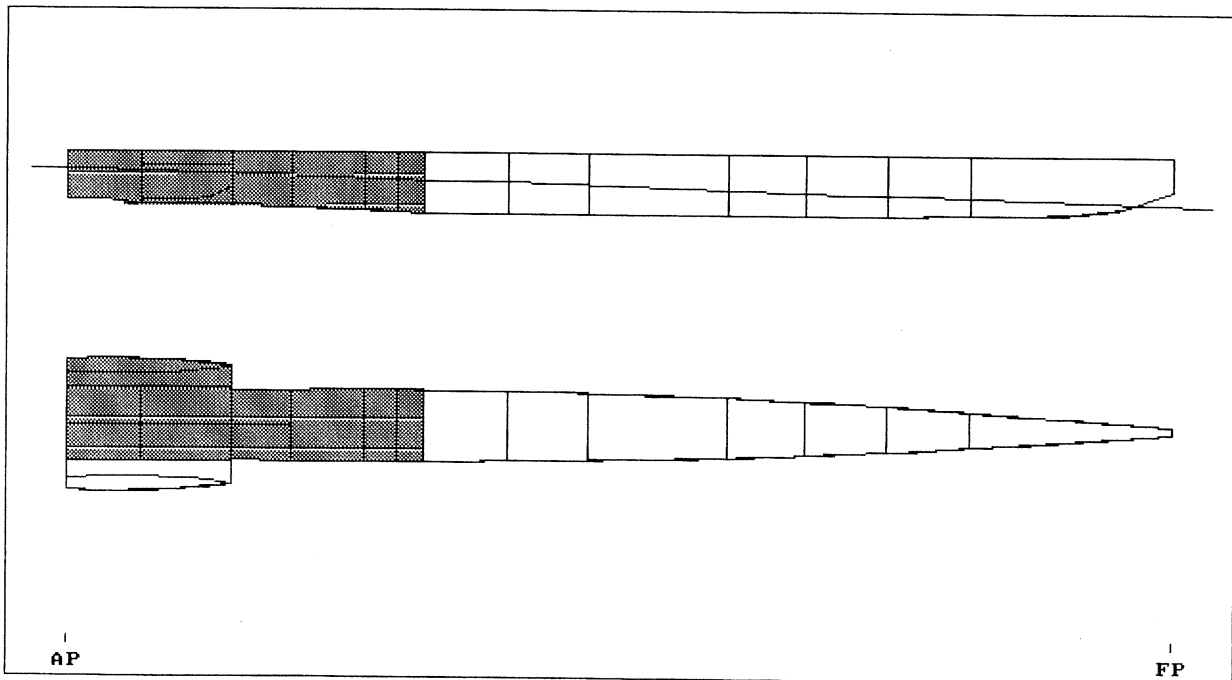


FREE-FLOATING DAMAGED CONDITION

Damaged Compartments:

M3S                    M3P                    M2S                    M2P                    SIDE\_P\_UP                    SIDE\_P  
 M1S                    M1P                    M6                    M5                    M4

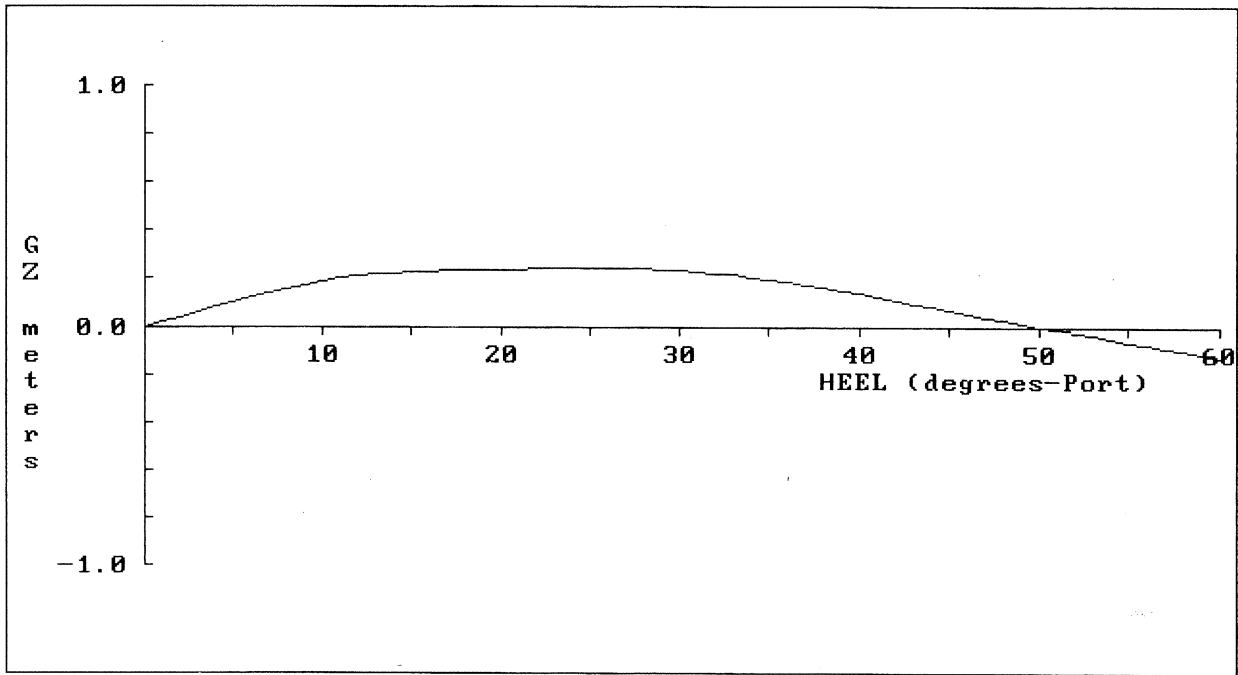
	DISPLACEMENT MTons	DRAFT AFT m	DRAFT FWD m	TRIM m	HEEL deg.	UPRIGHT GMT m
INTACT	2,966	3.62	4.01	0.39F	0.0	2.29
DAMAGED	5,153	7.23	2.26	4.97A	0.0P	1.70



**SALVAGE COMPARISON TABLE**

	Intact 1	Damage 1	Intact 2	Damage 2
Calculation Basis	HYDRO	OFFSETS	----	----
Case Name	----	----	----	----
Salvage (SAL) File	----	----	----	----
Draft AP (m)	3.62	7.23	----	----
Draft FP (m)	4.01	2.26	----	----
Trim on LBP (m)	0.39F	4.97A	----	----
Total Weight (MT)	2966	5153	----	----
Static Heel (deg)	0.0	0.0	----	----
WindHeel (deg)	----	----	----	----
GMT (upright) (m)	2.29	1.70	----	----
Maximum GZ (m)	----	0.24	----	----
Max.GZ Angle (deg)	----	25.6S	----	----
GZ Pos.Range (deg)	----	49.9	----	----
Outflow (MT)	----	----	----	----
Flooded Water (MT)	----	2187	----	----
Shear Force (MT)	----	----	----	----
B.Moment (m-MT)	----	----	----	----
anding Type	----	----	----	----
tidal Height (m)	----	----	----	----
Grd.Reaction (MT)	----	----	----	----
L.C.R. (m-AP)	----	----	----	----
T.C.R. (m)	----	----	----	----
Shelf Reaction (MT)	----	----	----	----
L.C.R. (m-AP)	----	----	----	----
T.C.R. (m)	----	----	----	----
Aft Bnd. (m-AP)	----	----	----	----
Fwd Bnd. (m-AP)	----	----	----	----
Water Depth (m)	----	----	----	----
Shelf Material	----	----	----	----
Coef. Friction	----	----	----	----
Brg.Cap./Density	----	----	----	----
Pinn.Reaction (MT)	----	----	----	----
Net Coef. Friction	----	----	----	----
Force to Free (ST)	----	----	----	----

RIGHTING ARM (GZ)



Stability Evaluation:

Static Heel Angle	0.0P deg
Angle at Maximum GZ	25.6P deg
Maximum GZ	0.24 m
Range of Positive GZ	49.9 deg
Gmt (upright damaged)	1.70 m

(Based on Direct Calculation from Hull Offsets)

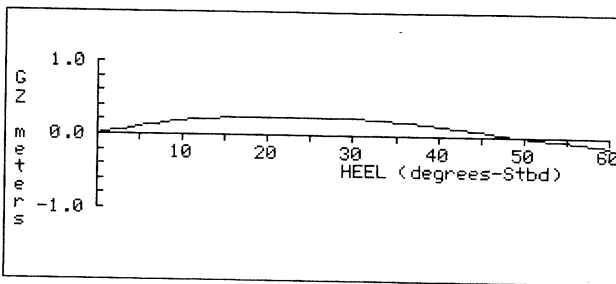
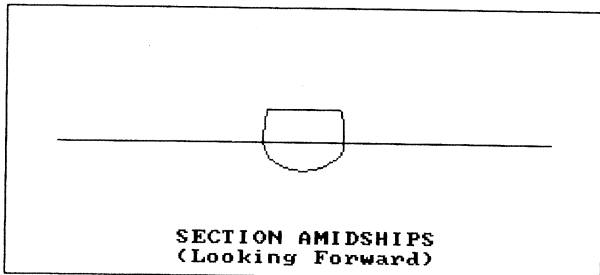
**DAMAGE EVALUATION SUMMARY**

**Stability Evaluation:**

Static Heel Angle                    0.0 deg  
 Angle at Maximum GZ                25.6S deg  
 Maximum GZ                         0.24 m  
 Range of Positive GZ                49.9 deg  
 Gmt (upright damaged)               1.70 m

**Summary of Breached Compartments:**

BREACHED COMPARTMENTS	PERM.	FLOODED WATER MTons	% FULL (Intact)	DENSITY MT/m3	OUTFLOW MTons
M3S	0.940	188	0.0	----	----
M3P	0.940	188	0.0	----	----
M2S	0.950	290	0.0	----	----
M2P	0.950	290	0.0	----	----
SIDE_P_UP	0.950	0	0.0	----	----
SIDE_P	0.001	0	0.0	----	----
M1S	0.850	198	0.0	----	----
M1P	0.850	198	0.0	----	----
M6	0.900	165	0.0	----	----
M5	0.900	204	0.0	----	----
M4	0.900	466	0.0	----	----
SIDE_S	0.001	0	0.0	----	----
SIDE_S_UP	0.950	0	0.0	----	----
TOTALS		2,187			----

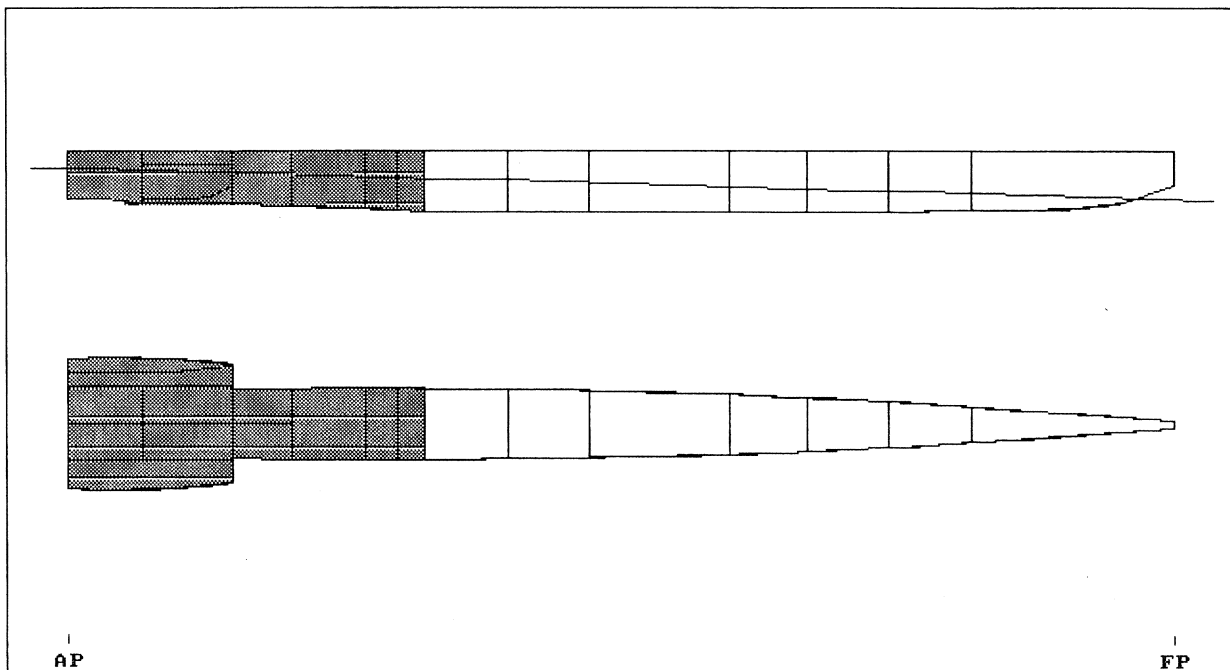


**FREE-FLOATING DAMAGED CONDITION**

**Damaged Compartments:**

M3S	M3P	M2S	M2P	SIDE_P_UP	SIDE_P
M1S	M1P	M6	M5	M4	SIDE_S
SIDE_S_UP					

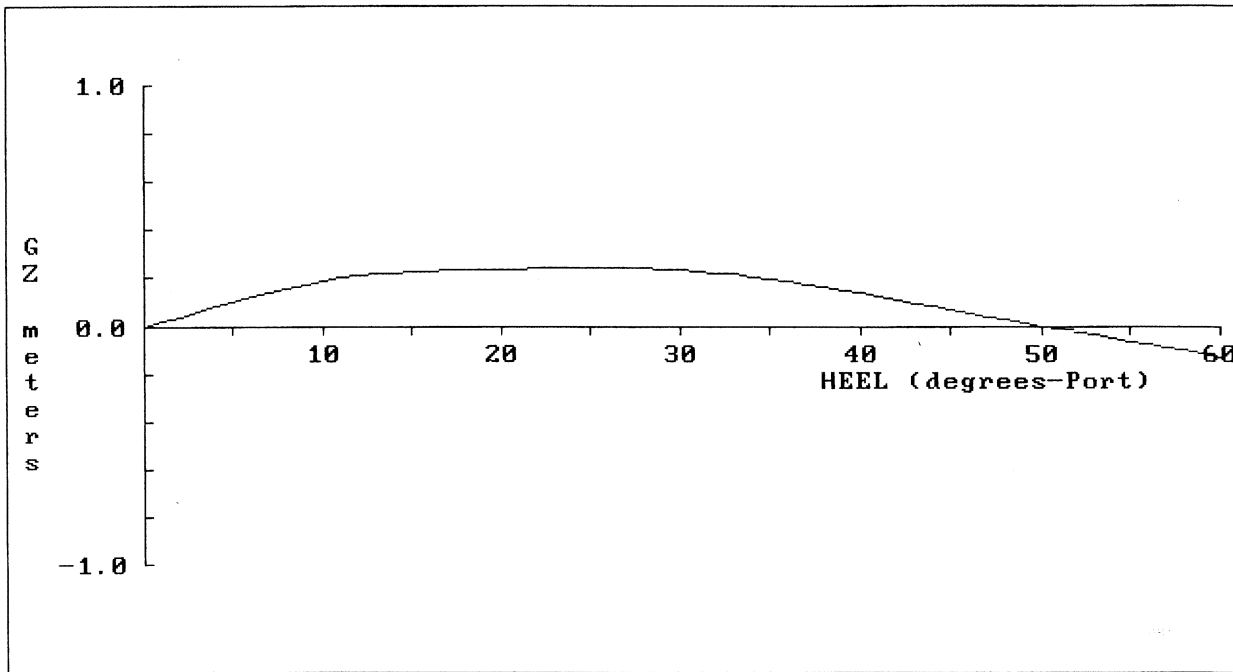
	DISPLACEMENT MTons	DRAFT AFT m	DRAFT FWD m	TRIM m	HEEL deg.	UPRIGHT GMT m
INTACT	2,966	3.62	4.01	0.39F	0.0	2.29
DAMAGED	5,153	7.23	2.26	4.97A	0.0	1.70



**SALVAGE COMPARISON TABLE**

	Intact 1	Damage 1	Intact 2	Damage 2
Calculation Basis	HYDRO	OFFSETS	----	----
Case Name	----	----	----	----
Salvage (SAL) File	----	----	----	----
Draft AP (m)	3.62	7.23	----	----
Draft FP (m)	4.01	2.26	----	----
Trim on LBP (m)	0.39F	4.97A	----	----
Total Weight (MT)	2966	5153	----	----
Static Heel (deg)	0.0	0.0P	----	----
WindHeel (deg)	----	----	----	----
GMT (upright) (m)	2.29	1.70	----	----
Maximum GZ (m)	----	0.24	----	----
Max.GZ Angle (deg)	----	25.6P	----	----
GZ Pos.Range (deg)	----	49.9	----	----
Outflow (MT)	----	----	----	----
Flooded Water (MT)	----	2187	----	----
Shear Force (MT)	----	----	----	----
B.Moment (m-MT)	----	----	----	----
anding Type	----	----	----	----
ual Height (m)	----	----	----	----
Grd.Reaction (MT)	----	----	----	----
L.C.R. (m-AP)	----	----	----	----
T.C.R. (m)	----	----	----	----
Shelf Reaction(MT)	----	----	----	----
L.C.R. (m-AP)	----	----	----	----
T.C.R. (m)	----	----	----	----
Aft Bnd. (m-AP)	----	----	----	----
Fwd Bnd. (m-AP)	----	----	----	----
Water Depth (m)	----	----	----	----
Shelf Material	----	----	----	----
Coef. Friction	----	----	----	----
Brg.Cap./Density	----	----	----	----
Pinn.Reaction (MT)	----	----	----	----
Net Coef. Friction	----	----	----	----
Force to Free (ST)	----	----	----	----

RIGHTING ARM (GZ)



Stability Evaluation:

Static Heel Angle	0.0P deg
Angle at Maximum GZ	25.6P deg
Maximum GZ	0.24 m
Range of Positive GZ	49.9 deg
Gmt (upright damaged)	1.70 m

(Based on Direct Calculation from Hull Offsets)

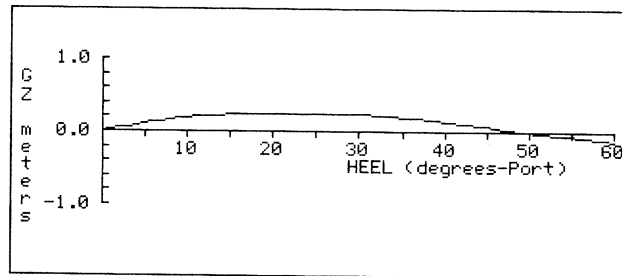
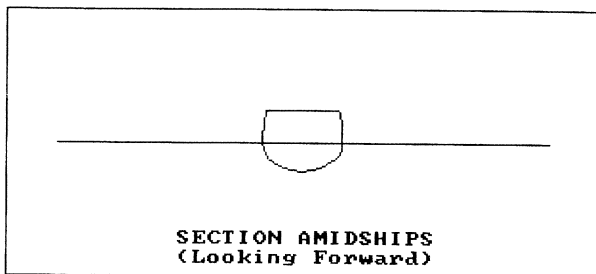
**DAMAGE EVALUATION SUMMARY**

**Stability Evaluation:**

Static Heel Angle                    0.0P deg  
 Angle at Maximum GZ                25.6P deg  
 Maximum GZ                            0.24 m  
 Range of Positive GZ                49.9 deg  
 Gmt (upright damaged)               1.70 m

**Summary of Breached Compartments:**

BREACHED COMPARTMENTS	PERM.	FLOODED WATER MTons	% FULL (Intact)	DENSITY MT/m3	OUTFLOW MTons
M3S	0.940	188	0.0	----	----
M3P	0.940	188	0.0	----	----
M2S	0.950	290	0.0	----	----
M2P	0.950	290	0.0	----	----
SIDE_P_UP	0.950	0	0.0	----	----
SIDE_P	0.001	0	0.0	----	----
M1S	0.850	198	0.0	----	----
M1P	0.850	198	0.0	----	----
M6	0.900	165	0.0	----	----
M5	0.900	204	0.0	----	----
M4	0.900	466	0.0	----	----
TOTALS		2,187			





## **H. Roll Period Calculations**

## Roll Period Calculation

In order to calculate the roll period of the trimaran we need first to calculate the roll radius of gyration:

Main hull beam:  $B := 11.7\text{m}$

Trimaran Displacement:  $D_{\text{trim}} := 3559\text{ton}$

Trimaran GM:  $\text{GMt} := 2.5\text{m}$

Sidehull Displacement:  $D_{\text{side}} := 27\text{ton}$

Sidehull Separation:  $c := 9.65\text{m}$

Main hull radius of gyration approximation:  $k_{\text{main}} := 0.4B$

Sidehull mass moment of inertia:  $I_{\text{side}} := D_{\text{side}} \cdot (c)^2$  (Assuming that the mass of the sidehull is a point mass)

### Trimaran Radius of Gyration

$$k_{\text{roll}} := \sqrt{k_{\text{main}}^2 + 2 \frac{I_{\text{side}}}{D_{\text{trim}}}} \quad k_{\text{roll}} = 4.829\text{m}$$

### Trimaran Added Moment of Inertia

$$I_{44} := D_{\text{trim}} \cdot k_{\text{roll}}^2 \quad I_{44} = 8.298 \times 10^4 \text{ton} \cdot \text{m}^2$$

If we assume that when the ship is rolling we need to calculate the added moment of inertia of the main hull in roll and the added moment of inertia of the sidehulls in heave, we have the following:

$$a_{44_{\text{main}}} := 0.35 \cdot I_{44} \quad (\text{It is an approximation found in "Seakeeping" by A R J M Lloyd})$$

$$a_{33_{\text{side}}} := D_{\text{side}} \quad (\text{It is an approximation found in "Seakeeping" by A R J M Lloyd})$$

$$a_{44_{\text{trim}}} := a_{44_{\text{main}}} + 2 \cdot a_{33_{\text{side}}} \cdot c^2$$

### Trimaran Roll Period

$$\omega := \sqrt{\frac{D_{\text{trim}} \cdot \text{GMt} \cdot 9.81 \frac{\text{m}}{\text{sec}^2}}{I_{44} + a_{44_{\text{trim}}}}} \quad T := \frac{2 \cdot \pi}{\omega} \quad T = 7.3\text{s}$$

## **I. Seakeeping Analysis**

**Sea State 5 (Head Seas)**

**LIMITS**

Flight Operations	
Roll	6.4 deg
Pitch	3 deg
Vertical Acceleration	1.47m/sec <sup>2</sup>

CG	
Roll	8 deg
Pitch	3 deg

Bridge	
Lateral Acceleration	1.962m/sec <sup>2</sup>
Vertical Acceleration	3.924m/sec <sup>2</sup>

**Speed  
12 Knots**

Flight Operations	
Roll	1.5 deg
Pitch	1.2 deg
Vertical Acceleration	0.68m/sec <sup>2</sup>

CG	
Roll	1.5 deg
Pitch	1.2 deg

Bridge	
Lateral Acceleration	0.204m/sec <sup>2</sup>
Vertical Acceleration	0.36m/sec <sup>2</sup>

**Speed  
19 Knots**

Flight Operations	
Roll	2 deg
Pitch	1.4 deg
Vertical Acceleration	

CG	
Roll	2 deg
Pitch	1.4 deg

Bridge	
Lateral Acceleration	
Vertical Acceleration	

**Speed  
25 Knots**

Flight Operations	
Roll	1 deg
Pitch	1.5 deg
Vertical Acceleration	1.38m/sec <sup>2</sup>

CG	
Roll	1 deg
Pitch	1.5 deg

Bridge	
Lateral Acceleration	0.276m/sec <sup>2</sup>
Vertical Acceleration	1.14m/sec <sup>2</sup>

**Sea State 5 (Seas 45 deg from bow)**

LIMITS			
<b>Flight Operations</b>		<b>CG</b>	
Roll	6.4 deg	Roll	8 deg
Pitch	3 deg	Pitch	3 deg
Vertical Acceleration	1.47m/sec <sup>2</sup>		
		<b>Bridge</b>	
		Lateral Acceleration	1.962m/sec <sup>2</sup>
		Vertical Acceleration	3.924m/sec <sup>2</sup>

<b>Flight Operations</b>		<b>CG</b>	
Roll	6 deg	Roll	6 deg
Pitch	1.4 deg	Pitch	1.4 deg
Vertical Acceleration	0.852m/sec <sup>2</sup>		
		<b>Bridge</b>	
		Lateral Acceleration	0.744m/sec <sup>2</sup>
		Vertical Acceleration	0.492m/sec <sup>2</sup>

**Speed**  
12 Knots

<b>Flight Operations</b>		<b>CG</b>	
Roll	10 deg	Roll	10 deg
Pitch	1.5 deg	Pitch	1.5 deg
Vertical Acceleration			
		<b>Bridge</b>	
		Lateral Acceleration	
		Vertical Acceleration	

**Speed**  
19 Knots

<b>Flight Operations</b>		<b>CG</b>	
Roll	7.9 deg	Roll	7.9 deg
Pitch	1.7 deg	Pitch	1.7 deg
Vertical Acceleration	1.44m/sec <sup>2</sup>		
		<b>Bridge</b>	
		Lateral Acceleration	1.52m/sec <sup>2</sup>
		Vertical Acceleration	0.9m/sec <sup>2</sup>

**Speed**  
25 Knots

Sea State 5 (Beam Seas)

LIMITS

Flight Operations	
Roll	6.4 deg
Pitch	3 deg
Vertical Acceleration	1.47m/sec2

CG	
Roll	8 deg
Pitch	3 deg

Bridge	
Lateral Acceleration	1.962m/sec2
Vertical Acceleration	3.924m/sec2

Speed  
12 Knots

Flight Operations	
Roll	5.8 deg
Pitch	0.5 deg
Vertical Acceleration	

CG	
Roll	5.8 deg
Pitch	0.5 deg

Bridge	
Lateral Acceleration	
Vertical Acceleration	

Speed  
19 Knots

Flight Operations	
Roll	10 deg
Pitch	0.5 deg
Vertical Acceleration	0.492 /sec2

CG	
Roll	10 deg
Pitch	0.5 deg

Bridge	
Lateral Acceleration	0.756m/sec2
Vertical Acceleration	0.492 /sec2

Speed  
25 Knots

Flight Operations	
Roll	12 deg
Pitch	0.5 deg
Vertical Acceleration	

CG	
Roll	11 deg
Pitch	0.5 deg

Bridge	
Lateral Acceleration	
Vertical Acceleration	

**Sea State 5 (Seas 45 deg from stern)**

LIMITS					
<b>Flight Operations</b>		<b>CG</b>		<b>Bridge</b>	
Roll	6.4 deg	Roll	8 deg	Lateral Acceleration	1.962m/sec <sup>2</sup>
Pitch	3 deg	Pitch	3 deg	Vertical Acceleration	3.924m/sec <sup>2</sup>
Vertical Acceleration	1.47m/sec <sup>2</sup>				
<b>Flight Operations</b>		<b>CG</b>		<b>Bridge</b>	
Roll	5.3 deg	Roll	5.3 deg	Lateral Acceleration	0.156m/sec <sup>2</sup>
Pitch	1.2 deg	Pitch	1.2 deg	Vertical Acceleration	0.12m/sec <sup>2</sup>
Vertical Acceleration	0.24m/sec <sup>2</sup>				
<b>Flight Operations</b>		<b>CG</b>		<b>Bridge</b>	
Roll	4.1 deg	Roll	4.1 deg	Lateral Acceleration	
Pitch	1.2 deg	Pitch	1.2 deg	Vertical Acceleration	
Vertical Acceleration					
<b>Flight Operations</b>		<b>CG</b>		<b>Bridge</b>	
Roll	4.1 deg	Roll	4.1 deg	Lateral Acceleration	0.015m/sec <sup>2</sup>
Pitch	1.2 deg	Pitch	1.2 deg	Vertical Acceleration	0.036m/sec <sup>2</sup>
Vertical Acceleration	0.072m/sec <sup>2</sup>				

**Speed**  
12 Knots

**Speed**  
19 Knots

**Speed**  
25 Knots

**Sea State 5 (Stern Seas)**

**LIMITS**

Flight Operations	
Roll	6.4 deg
Pitch	3 deg
Vertical Acceleration	1.47m/sec <sup>2</sup>

CG	
Roll	8 deg
Pitch	3 deg

Bridge	
Lateral Acceleration	1.962m/sec <sup>2</sup>
Vertical Acceleration	3.924m/sec <sup>2</sup>

**Speed  
12 Knots**

Flight Operations	
Roll	0.8 deg
Pitch	1.2 deg
Vertical Acceleration	0.13m/sec <sup>2</sup>

CG	
Roll	0.8 deg
Pitch	1.2 deg

Bridge	
Lateral Acceleration	0.019m/sec <sup>2</sup>
Vertical Acceleration	0.036m/sec <sup>2</sup>

**Speed  
19 Knots**

Flight Operations	
Roll	0 deg
Pitch	0.8 deg
Vertical Acceleration	

CG	
Roll	0 deg
Pitch	0.8 deg

Bridge	
Lateral Acceleration	
Vertical Acceleration	

**Speed  
25 Knots**

Flight Operations	
Roll	0 deg
Pitch	0.7 deg
Vertical Acceleration	0.072m/sec <sup>2</sup>

CG	
Roll	0 deg
Pitch	0.7 deg

Bridge	
Lateral Acceleration	0.504m/sec <sup>2</sup>
Vertical Acceleration	0.024m/sec <sup>2</sup>



# J. Electrical Loading

ASSET/MONOSC V4.4.1 - MACHINERY MODULE - 4/23/2003 14:36. 2  
 DATABANK-C:\ASSET441\MONOSC\MSC441.BNK SHIP-TRIMARAN IIE

PRINTED REPORT NO. 11 - ELECTRIC LOADS

ELECT LOAD DES MARGIN FAC	0.200	ELECT LOAD SL MARGIN FAC	0.200
400-HZ ELECT LOAD FAC	0.200	MAX 400-HZ ELEC LOAD	78.803
24-HR AVG ELECT LOAD	1486.1	TOTAL SUMMER CRUISE LOAD	1872.8
CONNECTED ELECT LOAD	7014.5	TOTAL WINTER CRUISE LOAD	2587.5
MAX MARG ELEC LOAD	3677.1	TOTAL SUMMER BATTLE LOAD	2302.5
MAX STBY ELECT LOAD	1984.0	TOTAL WINTER BATTLE LOAD	2647.0
VITAL ELECT LOAD	1928.3	TOTAL ANCHOR LOAD	1984.0
		TOTAL EMERGENCY LOAD	660.8

SWBS	COMPONENT	CRUISE		BATTLE		ANCHOR	EMERG.
		SUMMER	WINTER	SUMMER	WINTER		
=====	=====	=====	=====	=====	=====	=====	=====
200	PROPULSION PLANT	266.0	403.5	369.9	500.3	102.6	103.7
230	PROPULSION UNITS	6.3	6.3	6.3	6.3	20.0	6.3
233	DIESEL ENGINES	1.2	1.2	1.2	1.2	0.0	1.2
234	GAS TURBINES	5.1	5.1	5.1	5.1	20.0	5.1
240	TRANSMISSION+PROPULSORS	2.6	2.6	19.7	19.7	0.8	8.5
241	REDUCTION GEARS	0.0	0.0	0.0	0.0	0.8	0.0
243	SHAFTING	2.6	2.6	2.6	2.6	0.0	0.0
245	PROPULSORS	0.0	0.0	17.1	17.1	0.0	8.5
250	SUPPORT SYSTEMS	233.7	371.3	320.6	450.9	77.8	88.9
251	COMBUSTION AIR SYSTEM	72.4	210.0	159.3	289.6	0.0	0.0
252	PROPULSION CONTROL SYS	16.5	16.5	16.5	16.5	5.4	16.5
256	CIRC + COOL SEA WATER	144.8	144.8	144.8	144.8	72.4	72.4
260	PROPUL FUEL & LUBE OIL	23.4	23.4	23.4	23.4	4.0	0.0
261	FUEL SERVICE SYSTEM	22.4	22.4	22.4	22.4	3.3	0.0
264	LUBE OIL HANDLING	1.0	1.0	1.0	1.0	0.7	0.0
300	ELECTRIC PLANT, GENERAL	147.0	147.0	199.0	199.0	139.8	51.6
310	ELECTRIC POWER GENERATIO	78.7	78.7	130.7	130.7	71.5	6.1
311	SHIP SERVICE POWER GENE	66.8	66.8	114.6	114.6	66.8	0.0
313	BATTERIES+SERVICE FACIL	3.0	3.0	4.0	4.0	1.5	0.0
314	POWER CONVERSION EQUIPM	8.9	8.9	12.2	12.2	3.2	6.1
330	LIGHTING SYSTEM	68.3	68.3	68.3	68.3	68.3	45.5
400	COMMAND+SURVEILLANCE	301.2	301.2	394.0	394.0	174.2	164.3
410	COMMAND+CONTROL SYS	15.7	15.7	18.1	18.1	3.1	0.0
420	NAVIGATION SYS	4.6	4.6	6.6	6.6	1.8	3.3
430	INTERIOR COMMUNICATIONS	9.9	9.9	9.9	9.9	7.9	5.0
440	EXTERIOR COMMUNICATIONS	22.4	22.4	37.4	37.4	13.4	18.7
450	SURF SURV SYS (RADAR)	86.0	86.0	86.0	86.0	43.0	43.0
452	AIR SEARCH RADAR (2D)	79.0	79.0	79.0	79.0	0.0	0.0
455	IDENTIFICATION SYSTEMS	7.0	7.0	7.0	7.0	0.0	0.0
470	COUNTERMEASURES	38.9	38.9	38.9	38.9	38.9	0.0
475	DEGAUSSING	38.9	38.9	38.9	38.9	38.9	0.0
480	FIRE CONTROL SYS	115.5	115.5	188.7	188.7	57.8	94.3
481	GUN FIRE CONTROL SYSTEM	3.2	3.2	10.4	10.4	0.0	0.0
482	MISSILE FIRE CONTROL SY	85.0	85.0	151.0	151.0	0.0	0.0

483 UNDERWATER FIRE CONTROL	19.5	19.5	19.5	19.5	0.0	0.0
484 INTEGRATED FIRE CONTROL	3.0	3.0	3.0	3.0	0.0	0.0
490 SPECIAL PURPOSE SYS	8.1	8.1	8.4	8.4	8.1	0.0
491 ELCTRNC TEST,CHKOUT,MON	5.6	5.6	5.9	5.9	5.6	0.0
493 NON-COMBAT DATA PROCESS	2.5	2.5	2.5	2.5	2.5	0.0
500 AUXILIARY SYSTEMS	1110.5	1681.0	1275.0	1482.5	1527.0	295.2
510 CLIMATE CONTROL	517.1	1087.6	394.7	602.2	1077.9	154.0
511 COMPARTMENT HEATING SYS	13.3	870.8	13.3	435.4	870.8	0.0
512 VENTILATION SYSTEM	161.7	161.7	111.7	111.7	161.7	22.3
514 AIR CONDITIONING SYSTEM	335.8	48.8	263.3	48.8	39.0	131.7
516 REFRIGERATION SYSTEM	1.3	1.3	1.3	1.3	1.3	0.0
517 AUX BOILERS+OTHER HEAT	5.0	5.0	5.0	5.0	5.0	0.0
520 SEA WATER SYSTEMS	84.4	84.4	97.7	97.7	84.1	97.7
521 FIREMAIN+SEA WATER FLUS	83.8	83.8	97.7	97.7	83.8	97.7
529 DRAINAGE+BALLASTING SYS	0.6	0.6	0.0	0.0	0.3	0.0
530 FRESH WATER SYSTEMS	36.0	36.0	13.5	13.5	36.0	4.7
531 DISTILLING PLANT	18.2	18.2	0.0	0.0	18.2	0.0
532 COOLING WATER	9.4	9.4	9.4	9.4	9.4	4.7
533 POTABLE WATER	8.4	8.4	4.1	4.1	8.4	0.0
540 FUELS/LUBRICANTS,HANDLIN	21.5	21.5	21.5	21.5	21.5	0.0
541 SHIP FUEL+COMPENSATING	21.5	21.5	21.5	21.5	21.5	0.0
550 AIR,GAS+MISC FLUID SYSTE	301.6	301.6	574.8	574.8	301.6	0.0
551 COMPRESSED AIR SYSTEMS	301.6	301.6	574.8	574.8	301.6	0.0
560 SHIP CNTL SYS	144.9	144.9	167.9	167.9	0.0	38.8
561 STEERING+DIVING CNTL SY	38.8	38.8	38.8	38.8	0.0	38.8
565 TRIM+HEEL SYSTEMS	106.1	106.1	129.1	129.1	0.0	0.0
590 SPECIAL PURPOSE SYSTEMS	5.0	5.0	5.0	5.0	6.0	0.0
593 ENVIRONMENTAL POLLUTION	5.0	5.0	5.0	5.0	6.0	0.0
600 OUTFIT+FURNISHING,GENERAL	32.1	38.8	17.5	24.1	31.4	4.0
620 HULL COMPARTMENTATION	3.5	10.2	3.5	10.2	2.8	0.0
625 AIRPORTS,FIXED PORTLIGH	3.5	10.2	3.5	10.2	2.8	0.0
630 PRESERVATIVES+COVERINGS	7.2	7.2	7.2	7.2	7.2	0.0
633 CATHODIC PROTECTION	7.2	7.2	7.2	7.2	7.2	0.0
650 SERVICE SPACES	19.6	19.6	6.7	6.7	19.6	4.0
651 COMMISSARY SPACES	17.6	17.6	2.7	2.7	17.6	0.0
652 MEDICAL SPACES	0.0	0.0	4.0	4.0	0.0	4.0
655 LAUNDRY SPACES	1.4	1.4	0.0	0.0	1.4	0.0
656 TRASH DISPOSAL SPACES	0.6	0.6	0.0	0.0	0.6	0.0
660 WORKING SPACES	1.8	1.8	0.0	0.0	1.8	0.0
665 WORKSHOPS,LABS,TEST ARE	1.8	1.8	0.0	0.0	1.8	0.0
700 ARMAMENT	16.0	16.0	47.0	47.0	9.0	42.0
710 GUNS+AMMUNITION	14.0	14.0	42.0	42.0	7.0	42.0
711 GUNS	14.0	14.0	42.0	42.0	0.0	0.0
750 TORPEDOES	2.0	2.0	5.0	5.0	2.0	0.0
TOTAL LOADS	1873.	2587.	2302.	2647.	1984.	661.
TOTAL MARGINED LOADS	2618.	3615.	3212.	3677.	2827.	917.

## **K. Structural Analysis**

**SHEAR & LONGITUDINAL BENDING STRESS SUMMARY**

Stresses in ksi

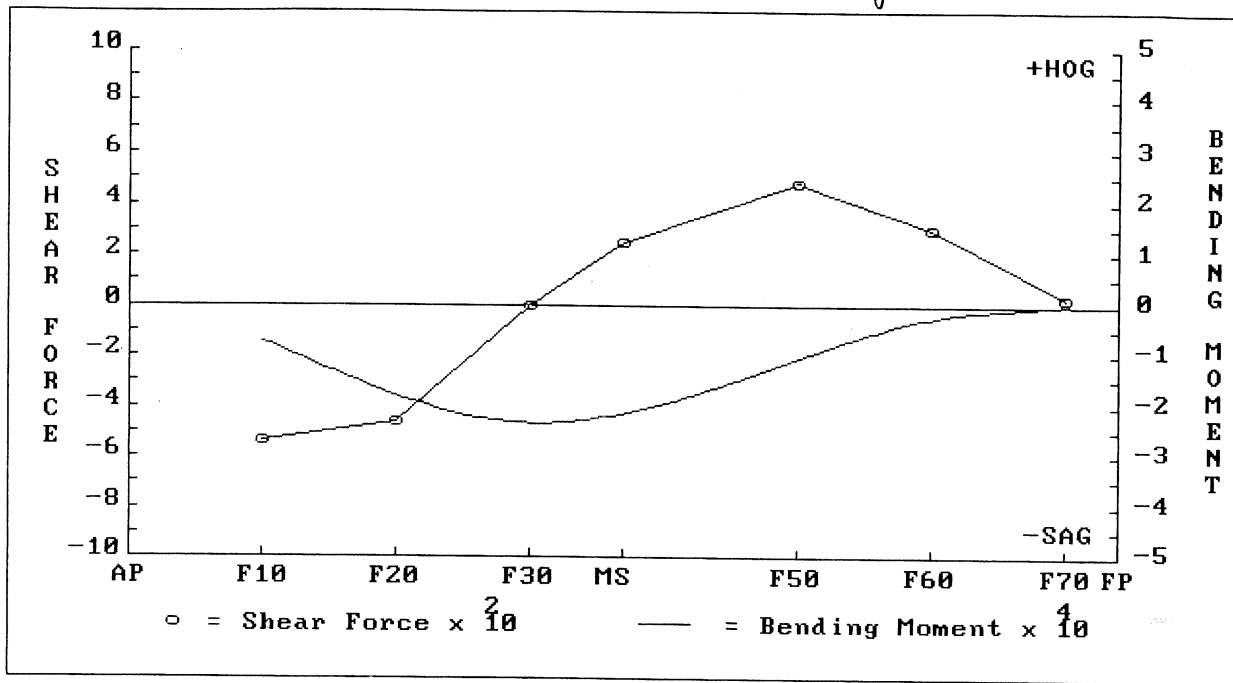
*Minimum Condition (Sagging)*

No.	LOCATION m-AP	SHEAR FORCES		BENDING MOMENTS		
		SHEAR MTons	SHEAR STRESS ksi	MOMENT m-MTons	DK STRESS ksi	KL STRESS ksi
F10	20.00F	-542		7,201S		
F20	40.00F	-465		17,780S		
F30	60.00F	-2		23,395S		
MS	74.00F	249	1.0	21,622S	-15.8	12.6
F50	100.00F	482		11,103S		
F60	120.00F	296		2,865S		
F70	140.00F	28		90S		

Maximum Shear Stress at MS : 0.96 ksi  
 Maximum Deck Bending Stress at MS : -15.76 ksi  
 Maximum Keel Bending Stress at MS : 12.60 ksi

SHEAR FORCE & BENDING MOMENT SUMMARY

Minimum Condition (Sagging)



No.	SHEAR FORCES			BENDING MOMENTS			
	LOCATION m-AP	BUOYANCY MTons	WEIGHT MTons	SHEAR MTons	BUOY. MOM. m-MTons	WT. MOM. m-MTons	MOMENT m-MTons
F10	20.00F	1,051	509	-542	10,837	3,636	7,201S
F20	40.00F	1,583	1,119	-465	37,897	20,117	17,780S
F30	60.00F	1,774	1,772	-2	71,838	48,443	23,395S
MS	74.00F	1,846	2,095	249	97,174	75,551	21,622S
F50	100.00F	2,132	2,614	482	148,087	136,985	11,103S
F60	120.00F	2,671	2,967	296	195,647	192,782	2,865S
F70	140.00F	3,228	3,256	28	255,162	255,072	90S

Maximum Shear Force at F10: -542 MT  
 Maximum Bending Moment at F30: 23,395 m-MTons [SAG]

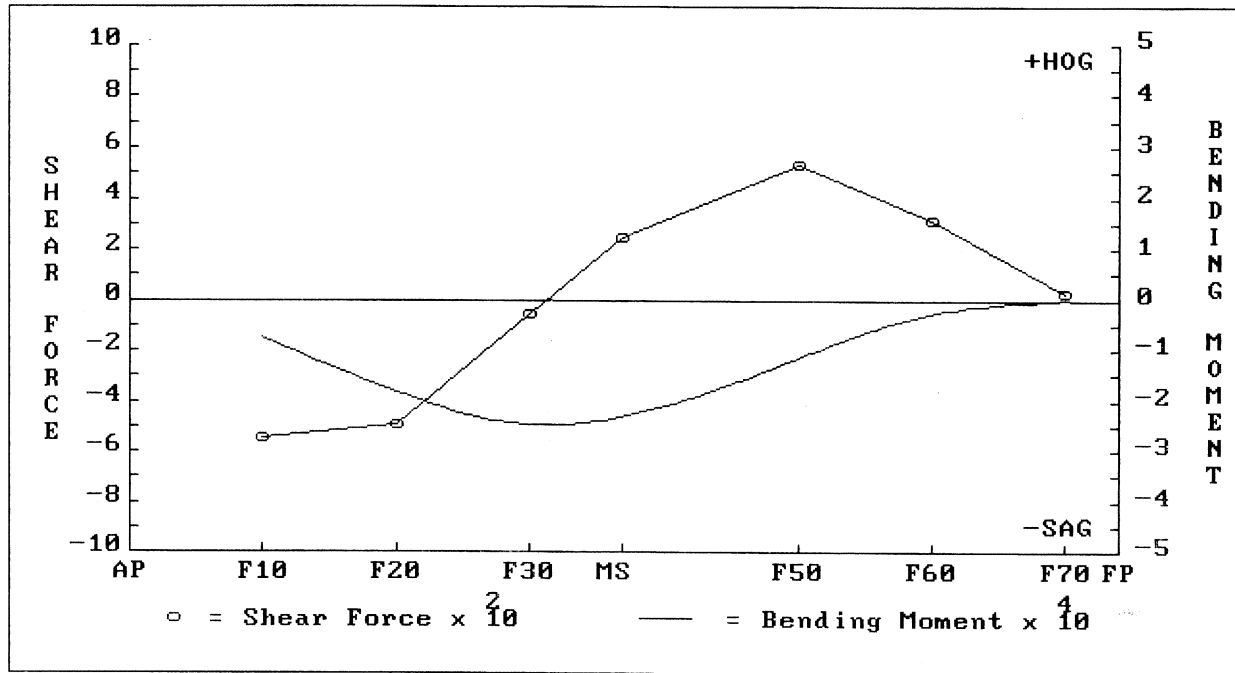
**SHEAR & LONGITUDINAL BENDING STRESS SUMMARY**  
**Stresses in ksi**

*Maximum Loading Condition (Sagging)*

No.	LOCATION m-AP	SHEAR FORCES		BENDING MOMENTS		
		SHEAR MTons	SHEAR STRESS ksi	MOMENT m-MTons	DK STRESS ksi	KL STRESS ksi
F10	20.00F	-545		7,517S		
F20	40.00F	-494		18,091S		
F30	60.00F	-53		24,692S		
MS	74.00F	247	0.9	23,270S	-17.0	13.6
F50	100.00F	532		12,001S		
F60	120.00F	311		2,950S		
F70	140.00F	28		75S		
Maximum Shear Stress at MS :				0.95 ksi		
Maximum Deck Bending Stress at MS :				-16.96 ksi		
Maximum Keel Bending Stress at MS :				13.56 ksi		

**SHEAR FORCE & BENDING MOMENT SUMMARY**

*Maximum Loading Condition (Sagging)*



No.	LOCATION	SHEAR FORCES			BENDING MOMENTS		
		BUOYANCY MTons	WEIGHT MTons	SHEAR MTons	BUOY. MOM. m-MTons	WT. MOM. m-MTons	MOMENT m-MTons
F10	20.00F	1,113	568	-545	11,467	3,950	7,517S
F20	40.00F	1,691	1,197	-494	40,235	22,145	18,091S
F30	60.00F	1,918	1,865	-53	76,706	52,014	24,692S
MS	74.00F	2,010	2,257	247	104,210	80,939	23,270S
F50	100.00F	2,334	2,866	532	159,857	147,856	12,001S
F60	120.00F	2,898	3,209	311	211,725	208,776	2,950S
F70	140.00F	3,468	3,496	28	275,952	275,877	75S

Maximum Shear Force at F10: -545 MT  
 Maximum Bending Moment at F30: 24,692 m-MTons [SAG]

**SHEAR & LONGITUDINAL BENDING STRESS SUMMARY**  
**Stresses in ksi**

*Minimum Loading Condition (Hogging)*

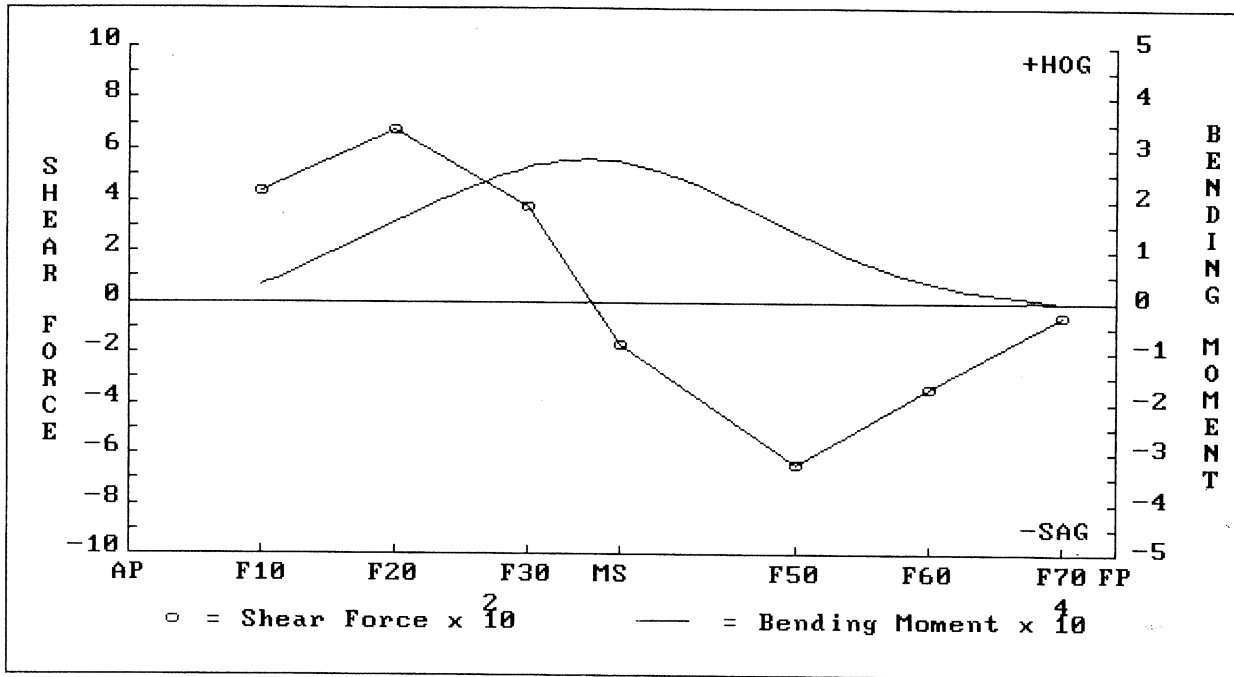
No.	LOCATION m-AP	SHEAR FORCES		BENDING MOMENTS		
		SHEAR MTons	SHEAR STRESS ksi	MOMENT m-MTons	DK STRESS ksi	KL STRESS ksi
F10	20.00F	436		3,068H		
F20	40.00F	677		15,296H		
F30	60.00F	371		26,163H		
MS	74.00F	-170	-0.7	27,611H	20.1	-16.1
F50	100.00F	-648		14,286H		
F60	120.00F	-344		4,046H		
F70	140.00F	-55		119H		

Maximum Shear Stress at MS : -0.65 ksi  
 Maximum Deck Bending Stress at MS : 20.13 ksi  
 Maximum Keel Bending Stress at MS : -16.09 ksi



**SHEAR FORCE & BENDING MOMENT SUMMARY**

*Minimum Loading Condition (Hogging)*



No.	LOCATION m-AP	SHEAR FORCES			BENDING MOMENTS		
		BUOYANCY MTons	WEIGHT MTons	SHEAR MTons	BUOY.MOM. m-MTons	WT.MOM. m-MTons	MOMENT m-MTons
F10	20.00F	73	509	436	568	3,636	3,068H
F20	40.00F	441	1,119	677	4,820	20,117	15,296H
F30	60.00F	1,401	1,772	371	22,280	48,443	26,163H
MS	74.00F	2,265	2,095	-170	47,940	75,551	27,611H
F50	100.00F	3,262	2,614	-648	122,699	136,985	14,286H
F60	120.00F	3,311	2,967	-344	188,736	192,782	4,046H
F70	140.00F	3,311	3,256	-55	254,953	255,072	119H

Maximum Shear Force at F20: 677 MT  
 Maximum Bending Moment at MS : 27,611 m-MTons [HOG]

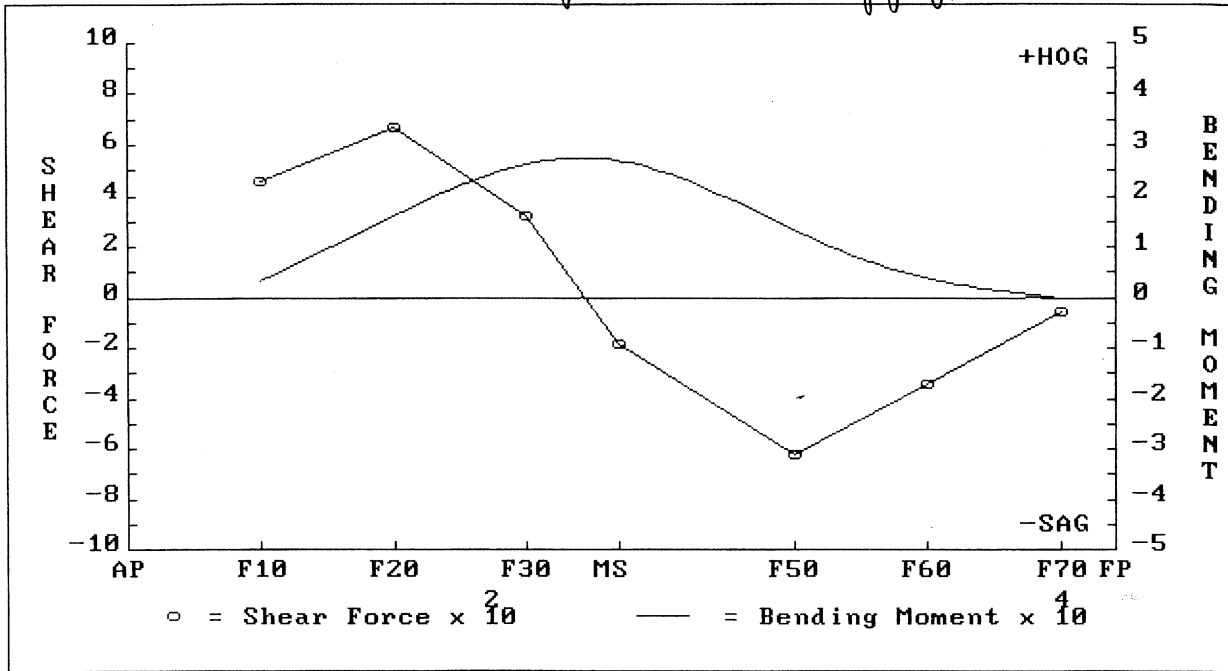
**SHEAR & LONGITUDINAL BENDING STRESS SUMMARY**  
**Stresses in ksi**

*Maximum Loading Condition (Hogging)*

No.	LOCATION m-AP	SHEAR FORCES		BENDING MOMENTS		
		SHEAR MTons	SHEAR STRESS ksi	MOMENT m-MTons	DK STRESS ksi	KL STRESS ksi
F10	20.00F	460		3,118H		
F20	40.00F	669		15,853H		
F30	60.00F	323		25,969H		
MS	74.00F	-183	-0.7	27,021H	19.7	-15.7
F50	100.00F	-625		13,901H		
F60	120.00F	-342		4,042H		
F70	140.00F	-55		115H		
Maximum Shear Stress at MS :			-0.70 ksi			
Maximum Deck Bending Stress at MS :			19.70 ksi			
Maximum Keel Bending Stress at MS :			-15.74 ksi			

SHEAR FORCE & BENDING MOMENT SUMMARY

Maximum Loading Condition (Hogging)



No.	LOCATION	SHEAR FORCES			BENDING MOMENTS		
		BUOYANCY MTons	WEIGHT MTons	SHEAR MTons	BUOY. MOM. m-MTons	WT. MOM. m-MTons	MOMENT m-MTons
F10	20.00F	109	568	460	832	3,950	3,118H
F20	40.00F	529	1,197	669	6,292	22,145	15,853H
F30	60.00F	1,542	1,865	323	26,044	52,014	25,969H
MS	74.00F	2,440	2,257	-183	53,918	80,939	27,021H
F50	100.00F	3,490	2,866	-625	133,955	147,856	13,901H
F60	120.00F	3,551	3,209	-342	204,733	208,776	4,042H
F70	140.00F	3,552	3,496	-55	275,762	275,877	115H

Maximum Shear Force at F20:                    669 MT  
 Maximum Bending Moment at MS :            27,021 m-MTons [HOG]

*Still-Min*

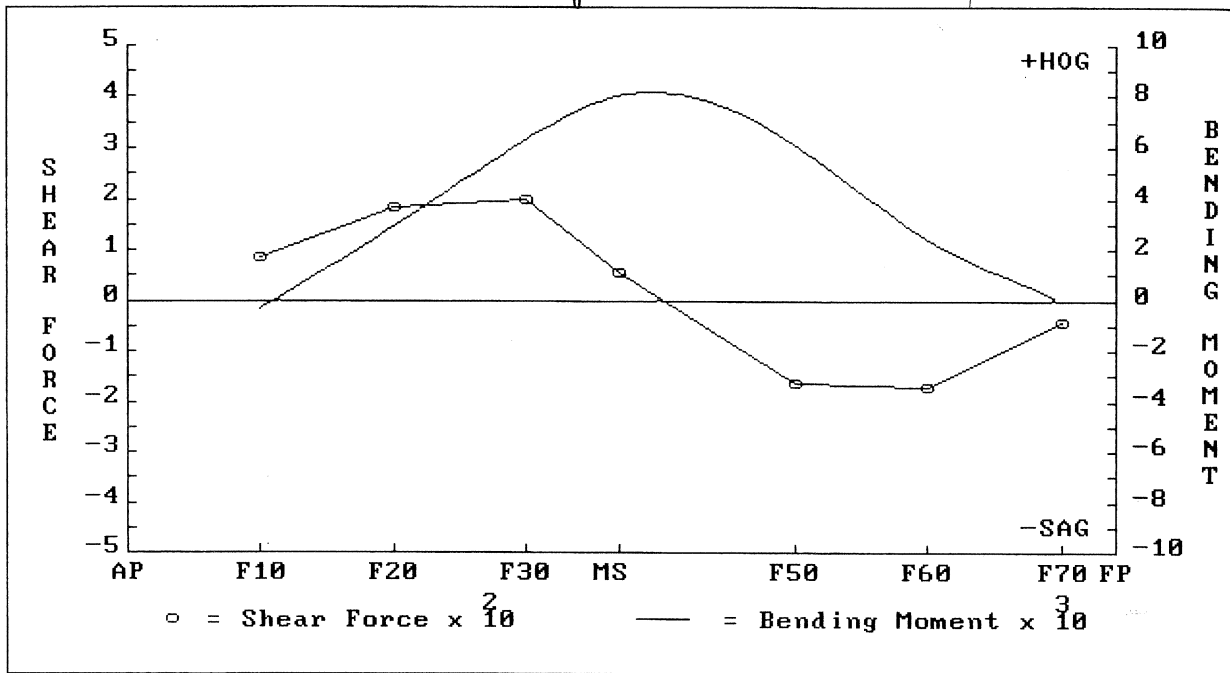
**SHEAR & LONGITUDINAL BENDING STRESS SUMMARY**  
**Stresses in ksi**

*(Stillwater) Minimum Loading Condition*

No.	LOCATION m-AP	SHEAR FORCES		BENDING MOMENTS		
		SHEAR MTons	SHEAR STRESS ksi	MOMENT m-MTons	DK STRESS ksi	KL STRESS ksi
F10	20.00F	86		322S		
F20	40.00F	185		2,856H		
F30	60.00F	198		6,248H		
MS	74.00F	54	0.2	8,027H	5.9	-4.7
F50	100.00F	-164		6,257H		
F60	120.00F	-170		2,590H		
F70	140.00F	-45		150H		
Maximum Shear Stress at MS :			0.21 ksi			
Maximum Deck Bending Stress at MS :			5.85 ksi			
Maximum Keel Bending Stress at MS :			-4.68 ksi			

**SHEAR FORCE & BENDING MOMENT SUMMARY**

*Minimum Loading Condition (Stillwater)*



No.	SHEAR FORCES			BENDING MOMENTS			
	LOCATION m-AP	BUOYANCY MTons	WEIGHT MTons	SHEAR MTons	BUOY.MOM. m-MTons	WT.MOM. m-MTons	MOMENT m-MTons
F10	20.00F	423	509	86	3,958	3,636	322S
F20	40.00F	934	1,119	185	17,261	20,117	2,856H
F30	60.00F	1,574	1,772	198	42,195	48,443	6,248H
MS	74.00F	2,041	2,095	54	67,525	75,551	8,027H
F50	100.00F	2,778	2,614	-164	130,728	136,985	6,257H
F60	120.00F	3,137	2,967	-170	190,192	192,782	2,590H
F70	140.00F	3,300	3,256	-45	254,922	255,072	150H

Maximum Shear Force at F30: 198 MT  
 Maximum Bending Moment at MS : 8,027 m-MTons [HOG]

**SHEAR & LONGITUDINAL BENDING STRESS SUMMARY**  
**Stresses in ksi**

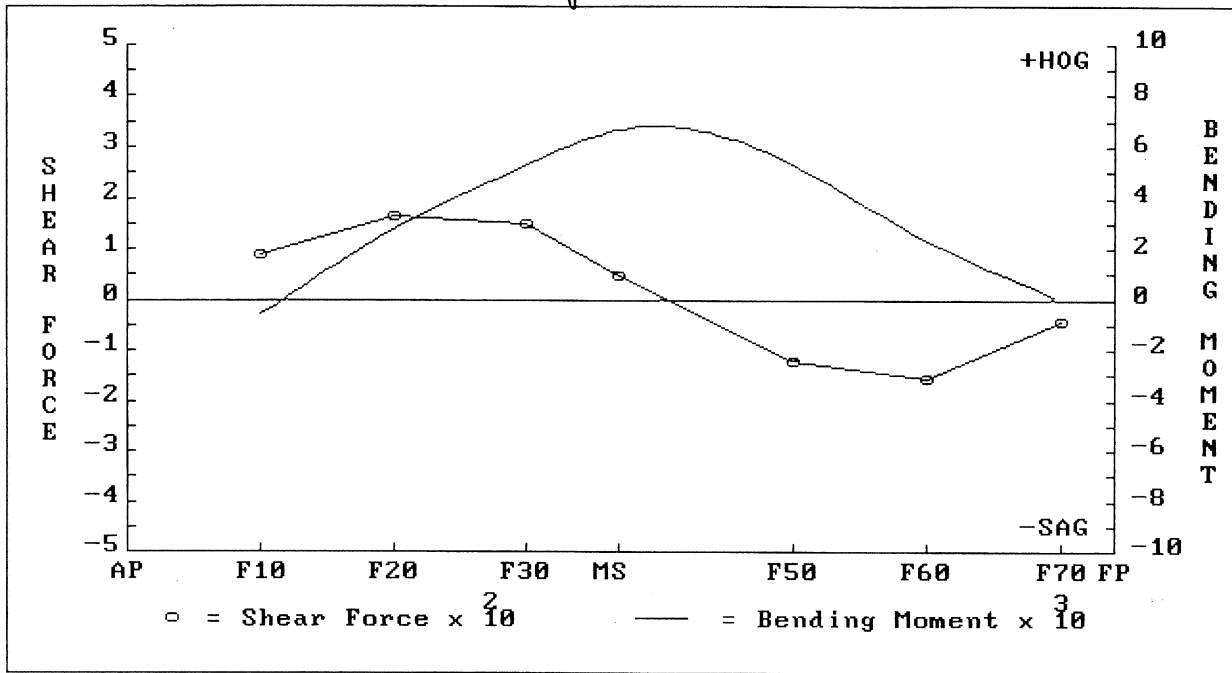
*Maximum Loading Condition (Still water)*

No.	LOCATION m-AP	SHEAR FORCES		BENDING MOMENTS		
		SHEAR MTons	SHEAR STRESS ksi	MOMENT m-MTons	DK STRESS ksi	KL STRESS ksi
F10	20.00F	88		588S		
F20	40.00F	163		2,724H		
F30	60.00F	149		5,226H		
MS	74.00F	48	0.2	6,647H	4.8	-3.9
F50	100.00F	-121		5,433H		
F60	120.00F	-157		2,487H		
F70	140.00F	-44		145H		

-----  
 Maximum Shear Stress at MS : 0.18 ksi  
 Maximum Deck Bending Stress at MS : 4.84 ksi  
 Maximum Keel Bending Stress at MS : -3.87 ksi

**SHEAR FORCE & BENDING MOMENT SUMMARY**

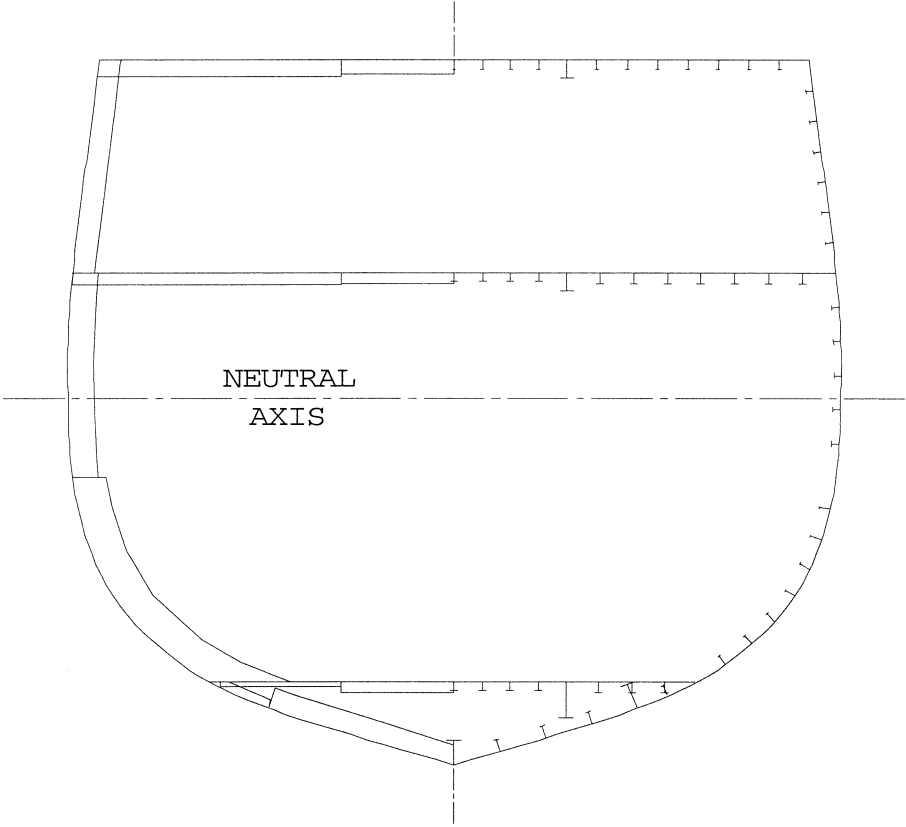
*Maximum Loading Condition (Still water)*



No.	LOCATION m-AP	SHEAR FORCES			BENDING MOMENTS		
		BUOYANCY MTons	WEIGHT MTons	SHEAR MTons	BUOY.MOM. m-MTons	WT.MOM. m-MTons	MOMENT m-MTons
F10	20.00F	480	568	88	4,538	3,950	588S
F20	40.00F	1,035	1,197	163	19,421	22,145	2,724H
F30	60.00F	1,716	1,865	149	46,788	52,014	5,226H
MS	74.00F	2,209	2,257	48	74,293	80,939	6,647H
F50	100.00F	2,987	2,866	-121	142,423	147,856	5,433H
F60	120.00F	3,366	3,209	-157	206,288	208,776	2,487H
F70	140.00F	3,540	3,496	-44	275,732	275,877	145H

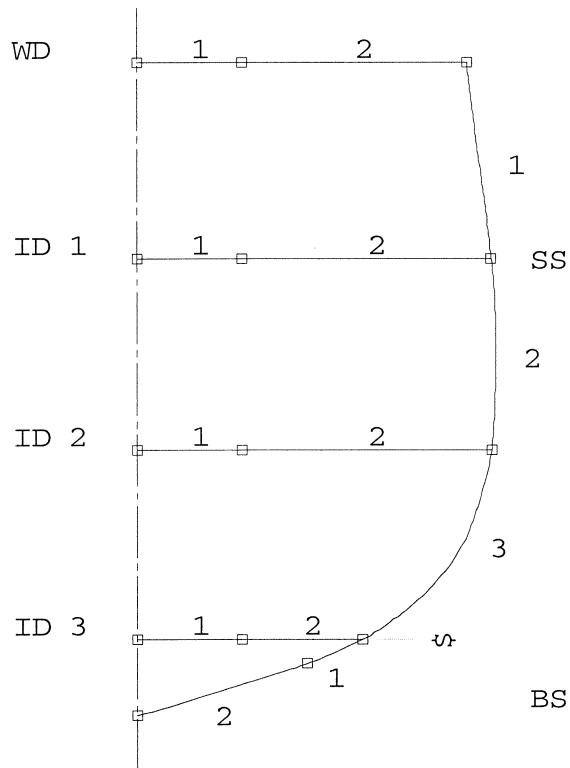
Maximum Shear Force at F20: 163 MT  
 Maximum Bending Moment at MS : 6,647 m-MTons [HOG]

ASSET/MONOSC V4.4.1 - HULL STRUCT MODULE - 4/24/2003 14:22.45  
DATABANK-C:\ASSET441\MONOSC\MSC441.BNK SHIP-TRIMARAN IIE  
GRAPHIC DISPLAY NO. 1 - SECTION AT THE STRUCTURAL DESIGN LOCATION





ASSET/MONOSC V4.4.1 - HULL STRUCT MODULE - 4/24/2003 14:22.45  
DATABANK-C:\ASSET441\MONOSC\MSC441.BNK SHIP-TRIMARAN IIE  
GRAPHIC DISPLAY NO. 2 - SEGMENT NODE POINTS



PRINTED REPORT NO. 1 - SUMMARY

INNER BOT IND- NONE HULL LOADS IND-CALC  
 STIFFENER SHAPE IND-CALC

----- HULL STRENGTH AND STRESS -----			
HOGGING BM, M-MTON	31645.	PRIM STRESS KEEL-HOG, MPA	126.84
SAGGING BM, M-MTON	36207.	PRIM STRESS KEEL-SAG, MPA	145.13
MIDSHIP MOI, M2-CM2	60267.	PRIM STRESS DECK-HOG, MPA	117.17
DIST N.A. TO KEEL, M	5.25	PRIM STRESS DECK-SAG, MPA	134.05
DIST N.A. TO DECK, M	4.84	HULL MARGIN STRESS, MPA	15.44
SEC MOD TO KEEL, M-CM2	11490.	SEC MOD TO DECK, M-CM2	12439.

HULL STRUCTURE COMPONENTS			
	MATERIAL TYPE	NO OF SEGMENT	NO
WET. DECK	HY 80	2	1
SIDE SHELL	HY 80	3	1
BOTTOM SHELL	HY 80	2	1
INNER BOTTOM	OS	2	
INT. DECK	OS	2	3
STRINGER, SHEER	HY 80	1	1
LONG BULKHEAD	OS		0
TRANS BULKHEAD	OS		12

HULL STRUCTURE WEIGHT			
SWBS	COMPONENT	WEIGHT, MTON	VCG, M
100	HULL STRUCTURE	714.2	5.44
110	SHELL+SUPPORT	340.3	4.13
120	HULL STRUCTURAL BHD	82.3	5.79
130	HULL DECKS	242.1	7.43
140	HULL PLATFORM/FLATS	49.6	4.10

PRINTED REPORT NO. 2 - HULL STRUCTURES WEIGHT

SWBS	COMPONENT	WT-MTON	VCG-M
100	HULL STRUCTURES	714.2	5.44
110	SHELL + SUPPORTS	340.3	4.13
111	PLATING	284.4	4.19
113	INNER BOTTOM		
115	STANCHIONS	2.5	5.04
116	LONG FRAMING	16.6	1.03
117	TRANS FRAMING	36.8	5.06
120	HULL STRUCTURAL BULKHDS	82.3	5.79
121	LONG BULKHDS		
122	TRANS BULKHDS	65.9	5.79
123	TRUNKS + ENCLOSURES	16.4	5.79
130	HULL DECKS	242.1	7.43
131	MAIN DECK	105.0	10.09
132	2ND DECK	98.7	7.03
133	3RD DECK	38.3	1.17
134	4TH DECK		
135	5TH DECK+DECKS BELOW		
136	01 HULL DECK		
137	02 HULL DECK		
138	03 HULL DECK		
139	04 HULL DECK		
140	HULL PLATFORMS/FLATS	49.6	4.10
141	1ST PLATFORM	49.6	4.10
142	2ND PLATFORM		
143	3RD PLATFORM		
144	4TH PLATFORM		
145	5TH PLAT+PLATS BELOW		
160	SPECIAL STRUCTURES		

164 BALLISTIC PLATING

\* DENOTES INCLUSION OF PAYLOAD OR ADJUSTMENTS

PRINTED REPORT NO. 3 - WEATHER DECK

DECK MTRL TYPE-HY 80

STRINGER PLATE MTRL TYPE-HY 80

	SHELL	STRINGER PLATE
MODULUS OF ELASTICITY, MPA	204084.8	204084.8
DENSITY, KG/M3	7833.41	7833.41
YIELD STRENGTH, MPA	551.58	551.58
MAX PRIMARY STRENGTH, MPA	162.16	162.16
ALLOWABLE WORKING STRENGTH, MPA	379.21	379.21

HULL LOADS IND-CALC

	MAX	MIN
STIFFENER SPACING, MM	457.20	457.20
STRINGER PLATE WIDTH, M	2.13	

SEGMENT GEOMETRY

SEG	-----NODE COORD, M -----				-----SCND. LOAD, M --	
	YIB	ZIB	YOB	ZOB	HEAD1	HEAD2
1	0.00	10.09	1.54	10.09	2.51	
2	1.54	10.09	4.83	10.09	2.51	

SEGMENT SCANTLINGS

-----SCANTLINGS OF STIFFENED PLATES-----								
SEG	STIFFENERS				CATLG	NO.OF	PLATE	SPACING
	MMXMMXMM/MM				NO	STIFF	TK, MM	MM
1 *R	124.968X	50.800X	3.048/	4.572	4.	4	9.5250	385.19
2 *R	124.968X	50.800X	3.048/	4.572	4.	7	9.5250	411.15

NOTE: \*R STANDS FOR ROLLED SHAPE

SEGMENT PROPERTIES

-----PROPERTIES OF STIFFENED PLATES-----								
SEG	-----AREA-----		N.A. TO	-----SEC MOD-----				SMEAR
	TOTAL	SHEAR	PLATE	PLATE	FLANGE	WT/M		RATIO
	CM2	CM2	MM	CM3	CM3	N/M		
1	43.14	4.24	18.82	306.38	47.94	331.41		0.18
2	45.61	4.24	18.82	306.38	47.94	350.40		0.16

PRINTED REPORT NO. 4 - SIDE SHELL

SIDE SHELL MTRL TYPE-HY 80

SHEER STRAKE MTRL TYPE-HY 80

	SHELL	SHEER STRAKE
MODULUS OF ELASTICITY, MPA	204084.8	204084.8
DENSITY, KG/M3	7833.41	3371.70
YIELD STRENGTH, MPA	551.58	551.58
MAX PRIMARY STRENGTH, MPA	162.16	162.16
ALLOWABLE WORKING STRENGTH, MPA	379.21	379.21

HULL LOADS IND-CALC

	MAX	MIN
STIFFENER SPACING, MM	508.00	508.00
SHEER STRAKE WIDTH, M	2.44	

SEGMENT GEOMETRY

SEG	-----NODE COORD, M -----				-----SCND. LOAD, M --	
	YUPR	ZUPR	YLWR	ZLWR	HEAD1	HEAD2
1	4.83	10.09	5.19	7.04	2.74	
2	5.19	7.04	5.20	4.12	5.73	
3	5.20	4.12	3.32	1.19	8.88	

SEGMENT SCANTLINGS

-----SCANTLINGS OF STIFFENED PLATES-----								
SEG	STIFFENERS				CATLG	NO.OF	PLATE	SPACING
	MMXMMXMM/MM				NO	STIFF	TK, MM	MM

1 \*R 99.568X 50.800X 3.048/ 4.572 2. 6 6.3500 438.58  
 2 \*R 99.568X 76.200X 3.048/ 4.572 5. 5 6.3500 488.37  
 3 \*R 152.146X 50.800X 4.572/ 7.874 10. 7 6.3500 451.14  
 NOTE: \*R STANDS FOR ROLLED SHAPE

SEGMENT PROPERTIES

-----PROPERTIES OF STIFFENED PLATES-----							
	-----AREA-----		N.A. TO	-----SEC MOD-----			SMEAR
SEG	TOTAL	SHEAR	PLATE	PLATE	FLANGE	WT/M	RATIO
	CM2	CM2	MM	CM3	CM3	N/M	
1	33.53	3.37	23.56	133.04	36.05	257.55	0.20
2	37.85	3.37	28.00	141.16	47.92	290.76	0.22
3	39.94	7.61	48.02	221.85	90.02	306.80	0.39

PRINTED REPORT NO. 5 - BOTTOM SHELL

BOTTOM SHELL MTRL TYPE-HY 80  
 MODULUS OF ELASTICITY, MPA 204084.8  
 DENSITY, KG/M3 7833.41  
 YIELD STRENGTH, MPA 551.58  
 MAX PRIMARY STRENGTH, MPA 162.16  
 ALLOWABLE WORKING STRENGTH, MPA 379.21

HULL LOADS IND-CALC

STIFFENER SPACING, MM MAX 762.00 MIN 762.00

SEGMENT GEOMETRY

SEG	-----NODE	COORD, M	-----SCND. LOAD, M --			
	YUPR	ZUPR	YLWR	ZLWR	HEAD1	HEAD2
1	3.32	1.19	2.51	0.82	10.31	
2	2.51	0.82	0.00	0.00	10.92	

SEGMENT SCANTLINGS

-----SCANTLINGS OF STIFFENED PLATES-----								
SEG	STIFFENERS			CATLG NO.	OF	PLATE	SPACING	
	-----MMXMMXMM-----	-----	-----	NO	STIFF	TK, MM	MM	
1 *R	152.146X	50.800X	4.572/	7.874	10.	1	9.5250	444.46
2 *R	177.546X	76.200X	4.572/	7.874	17.	3	10.3187	661.07

NOTE: \*R STANDS FOR ROLLED SHAPE

SEGMENT PROPERTIES

-----PROPERTIES OF STIFFENED PLATES-----							
	-----AREA-----		N.A. TO	-----SEC MOD-----			SMEAR
SEG	TOTAL	SHEAR	PLATE	PLATE	FLANGE	WT/M	RATIO
	CM2	CM2	MM	CM3	CM3	N/M	
1	53.63	7.75	31.11	426.21	95.77	411.95	0.27
2	82.73	8.95	39.39	612.05	154.21	635.53	0.21

PRINTED REPORT NO. 6 - INTERNAL DECKS

NUMBER OF INTERNAL DECKS 3

INTERNAL DECK MTRL TYPE-OS  
 MODULUS OF ELASTICITY, MPA 204084.8  
 DENSITY, KG/M3 7833.41  
 YIELD STRENGTH, MPA 234.42  
 MAX PRIMARY STRENGTH, MPA 131.28  
 ALLOWABLE WORKING STRENGTH, MPA 186.16

HULL LOADS IND-CALC

STIFFENER SPACING, MM MAX 457.20 MIN 457.20

SEGMENT GEOMETRY

SEG	-----NODE	COORD, M	-----SCND. LOAD, M --			
	YIB	ZIB	YOB	ZOB	HEAD1	HEAD2
DECK NO. 1	CONTINUOUS					
SEG						

1	0.00	7.04	1.54	7.04	0.81	8.13
2	1.54	7.04	5.19	7.04	0.81	8.96
DECK NO. 2 PLATFORM						
SEG						
1	0.00	4.12	1.54	4.12	0.81	8.13
2	1.54	4.12	5.20	4.12	0.81	8.96
DECK NO. 3 CONTINUOUS						
SEG						
1	0.00	1.19	1.54	1.19	0.81	8.13
2	1.54	1.19	3.32	1.19	0.81	8.96

SEGMENT SCANTLINGS

-----SCANTLINGS OF STIFFENED PLATES-----								
STIFFENERS								
SEG	-----MMXMMXMM/MM-----				CATLG NO.	OF PLATE	SPACING	
					NO	TK, MM	MM	
DECK NO. 1 CONTINUOUS								
SEG								
1	*R 120.142X 100.584X	4.826/	5.334	2.	4	6.3500	385.19	
2	*R 145.669X 100.838X	5.080/	5.715	5.	7	6.3500	456.54	
DECK NO. 2 PLATFORM								
SEG								
1	*R 120.142X 100.584X	4.826/	5.334	2.	4	6.3500	385.19	
2	*F 144.399X 100.076X	4.318/	5.461	3.	8	6.3500	406.50	
DECK NO. 3 CONTINUOUS								
SEG								
1	*R 120.142X 100.584X	4.826/	5.334	2.	4	6.3500	385.19	
2	*R 145.669X 100.838X	5.080/	5.715	5.	3	6.3500	445.00	

NOTE: \*F STANDS FOR FABRICATED SHAPE  
\*R STANDS FOR ROLLED SHAPE

SEGMENT PROPERTIES

-----PROPERTIES OF STIFFENED PLATES-----							
-----AREA-----							
SEG	TOTAL	SHEAR	N.A. TO	SEC	MOD	WT/M	SMEAR
	CM2	CM2	PLATE	PLATE	FLANGE	N/M	RATIO
			MM	CM3	CM3		
DECK NO. 1 CONTINUOUS							
SEG							
1	35.62	6.36	32.64	258.95	85.23	273.64	0.46
2	42.15	8.01	41.61	320.01	114.67	323.81	0.45
DECK NO. 2 PLATFORM							
SEG							
1	35.62	6.36	32.64	258.95	85.23	273.64	0.46
2	37.49	6.75	39.10	314.72	105.09	288.00	0.45
DECK NO. 3 CONTINUOUS							
SEG							
1	35.62	6.36	32.64	258.95	85.23	273.64	0.46
2	41.42	8.01	41.61	320.01	114.67	318.18	0.47

PRINTED REPORT NO. 7 - STRENGTH AND STRESS OF STIFFENED PLATE  
AT DESIGN LOAD

INNER BOT IND- NONE

SEG	-PRIMARY TENSION	STRESS-COMP.	-LOCAL STRESS-BEND.	STRESS-SHEAR	STRENGTH-BUCKL.	STRENGTH-ULTIMATE	STRENGTH-COLUMN
	MPA	MPA	MPA	MPA	MPA	MPA	MPA
WET DECK							
1	117.17	134.05	100.26	27.90	430.84	434.32	364.75
2	117.17	134.05	107.38	29.88	395.98	416.13	364.75
SIDE SHELL							
1	103.13	112.97	166.26	43.79	154.67	292.16	374.22
2	75.64	71.64	290.94	101.86	124.74	267.27	400.53
3	111.54	99.16	221.72	64.57	146.17	285.47	494.14
BOT SHELL							
1	131.33	115.47	238.40	72.47	338.85	394.43	460.80
2	139.72	122.39	233.16	98.86	179.77	310.47	502.11
INT DECK							
NO. 1							
1	89.11	91.89	183.06	60.34	186.60	187.23	222.95

2	89.11	91.89	177.72	62.58	142.74	167.11	234.42
INT DECK							
NO. 2							
1	0.00	0.00	183.06	60.34	186.60	187.23	222.95
2	0.00	0.00	172.67	66.20	177.88	180.86	233.94
INT DECK							
NO. 3							
1	0.00	0.00	183.06	60.34	186.60	187.23	222.95
2	0.00	0.00	173.23	61.00	150.23	170.13	234.42

PRINTED REPORT NO. 8 - FACTOR OF SAFETY OF STIFFENED PLATE  
AT DESIGN LOAD

INNER BOT IND- NONE

SEG	--PLATE-- BUCKLING	-STIFFENER- SHEAR	-----STIFFENED PLATE-----		
			COMP+BEND	ULTIMATE	TENSION+BEND.
WET DECK					
1	3.04	8.15	1.23	1.62	2.27
2	2.78	7.61	1.20	1.55	2.22
SIDE SHELL					
1	1.14	5.20	1.12	1.17	2.04
2	1.03	2.23	1.01	1.28	1.72
3	1.01	3.52	1.20	1.42	1.71
BOT SHELL					
1	2.38	3.14	1.06	1.85	1.51
2	1.18	2.30	1.09	1.49	1.48
INT DECK					
NO. 1					
1	1.97	1.85	1.02	1.50	1.89
2	1.51	1.78	1.05	1.41	1.92
INT DECK					
NO. 2					
1	6.19	1.85	1.02	4.73	2.03
2	6.17	1.69	1.08	5.01	2.16
INT DECK					
NO. 3					
1	6.19	1.85	1.02	4.73	2.03
2	4.84	1.83	1.07	4.39	2.15

PRINTED REPORT NO. 9 - GIRDER PROPERTIES, STRENGTH ,STRESSES  
AND FACTOR OF SAFETY

DECK MTRL TYPE-HY 80  
BOT MTRL TYPE-HY 80

HULL LOADS IND-CALC  
GIRDER/STIFF., POSITION

	-----COORDINATE, M -----		--SCND. LOAD, M --	
	YLOC	ZLOC	HEAD1	HEAD2
WET DECK				
GIRDER				
1	1.54	10.09	2.58	
INT DECK 1.				
GIRDER				
1	1.54	7.04	0.84	3.47
INT DECK 2.				
GIRDER				
1	1.54	4.12	0.84	6.01
INT DECK 3.				
GIRDER				
1	1.54	1.19	0.84	8.54
BOTTOM				
GIRDER				
1	0.00	0.00	0.11	11.31
2	2.51	0.82	0.10	10.49

-----SCANTLINGS OF GDR/STF AND PLATE-----  
SUPPORT

GIRDER/STIFFENER				CATLG	PLATE	WIDTH
-----MMXMMXMM/MM-----				NO	TK, MM	MM
WET DECK						
GIRDER						
1	*R	252.222X	177.800X	6.350/	9.398	51. 9.5250 2669.57
INT DECK 1.						
GIRDER						
1	*R	438.785X	152.400X	7.620/	10.795	69. 6.3500 3366.91
INT DECK 2.						
GIRDER						
1	*R	517.525X	209.296X	10.160/	15.621	87. 6.3500 3369.99
INT DECK 3.						
GIRDER						
1	*R	517.525X	209.296X	10.160/	15.621	87. 6.3500 2430.76
BOTTOM						
GIRDER						
1	*R	353.314X	203.200X	9.398/	14.986	91. 14.9860 0.00
2	*R	353.314X	177.800X	9.398/	14.986	87. 14.9860 0.00
NOTE: *R STANDS FOR ROLLED SHAPE						

-----PROPERTIES OF GDR/STF AND PLATES-----							
-----AREA-----		N.A. TO		-----SEC MOD-----		SMEAR	
TOTAL	SHEAR	PLATE	PLATE	FLANGE	WT/M	RATIO	
CM2	CM2	MM	CM3	CM3	N/M		
WET DECK							
GIRDER							
1	336.50	17.22	100.36	896.29	526.71	2584.99	0.11
INT DECK 1.							
GIRDER							
1	263.67	34.74	203.02	1245.66	999.96	2025.50	0.23
INT DECK 2.							
GIRDER							
1	299.28	54.81	286.82	1780.05	2020.65	2299.09	0.40
INT DECK 3.							
GIRDER							
1	239.64	54.81	286.82	1780.05	2020.65	1840.93	0.55
BOTTOM							
GIRDER							
1	339.98	35.58	169.01	1623.04	1308.73	2611.73	0.23
2	314.99	35.51	171.45	1416.13	1176.52	2419.71	0.24

-----STRENGTH AND STRESSES OF GDR.STF-----							
AT DESIGN LOAD							
-PRIMARY STRESS-		-LOCAL STRESS-		-----STRENGTH-----			
TENSION	COMP.	BEND.	SHEAR	BUCKL.	ULTIMATE	COLUMN	
MPA	MPA	MPA	MPA	MPA	MPA	MPA	
WET DECK							
GIRDER							
1	117.17	134.05	243.12	103.38	437.47	439.31	499.76
INT DECK 1.							
GIRDER							
1	89.10	91.88	182.64	73.07	194.04	193.33	234.42
INT DECK 2.							
GIRDER							
1	0.00	0.00	177.58	80.16	207.93	207.21	234.42
INT DECK 3.							
GIRDER							
1	0.00	0.00	182.11	82.20	207.93	207.21	234.42
BOTTOM							
GIRDER							
1	145.13	126.84	360.13	184.11	456.11	454.49	551.58
2	133.74	117.45	371.44	171.06	456.11	454.49	550.38

-----FACTOR OF SAFETY OF GDR.STF-----				
AT DESIGN LOAD				
--PLATE-	-STIFFENER-	-----STIFFENED PLATE-----		
BUCKLING	SHEAR	COMP+BEND	ULTIMATE	TENSION+BEND.
WET DECK				
GIRDER				

1	2.13	2.20	1.02	1.55	1.46
INT DECK	1.				
GIRDER					
1	2.65	1.53	1.02	2.11	1.27
INT DECK	2.				
GIRDER					
1	2.34	1.39	1.19	1.87	1.05
INT DECK	3.				
GIRDER					
1	2.28	1.36	1.16	1.82	1.02
BOTTOM					
GIRDER					
1	3.14	1.24	1.05	2.50	1.31
2	2.96	1.33	1.02	2.35	1.23

PRINTED REPORT NO. 10 - LONGITUDINAL BULKHEADS

NUMBER OF LONG BHD 0

PRINTED REPORT NO. 11 - TRANSVERSE BULKHEADS

TRANS BHD MTRL TYPE-OS

MODULUS OF ELASTICITY, MPA	204084.8
DENSITY, KG/M3	7833.41
YIELD STRENGTH, MPA	234.42
MAX PRIMARY STRENGTH, MPA	131.28
ALLOWABLE WORKING STRENGTH, MPA	186.16

HULL LOADS IND-CALC

	MAX	MIN
STIFFENER SPACING, MM	457.20	762.00

SEGMENT GEOMETRY

SEG	YUPR	ZUPR	YLWR	ZLWR	HEAD1	HEAD2
1	0.00	10.09	0.00	7.04	5.22	
2	0.00	7.04	0.00	4.12	7.76	
3	0.00	4.12	0.00	1.19	9.35	
4	0.00	1.19	0.00	0.00	8.72	

SEGMENT SCANTLINGS

-----SCANTLINGS OF STIFFENED PLATES-----

SEG	STIFFENERS	CATLG NO.	NO OF	PLATE	SPACING
MMxMMxMM/MM	NO	STIFF	TK, MM	MM	
1 *R 145.669x 100.838x 5.080/ 5.715	5	15	4.7625	438.51	
2 *F 245.364x 100.584x 4.826/ 5.334	14	15	4.7625	418.00	
3 *F 296.799x 100.838x 5.080/ 5.715	24	16	4.7625	434.64	
4 *F 296.799x 100.838x 5.080/ 5.715	24	11	4.7625	440.94	

NOTE: \*F STANDS FOR FABRICATED SHAPE

\*R STANDS FOR ROLLED SHAPE

SEGMENT PROPERTIES

-----PROPERTIES OF STIFFENED PLATES-----

SEG	AREA	N.A. TO	SEC MOD	FLANGE	WT/M	SMEAR
TOTAL	SHEAR	PLATE	PLATE	CM3	N/M	RATIO
CM2	CM2	MM	CM3			
1	34.05	7.93	55.63	197.99	109.56	261.53
2	37.13	12.33	94.10	342.54	199.76	285.25
3	41.54	15.61	118.91	430.19	271.56	319.09
4	41.84	15.61	118.91	430.19	271.56	321.40

-----STRENGTH AND STRESSES-----

AT DESIGN LOAD

SEG	LOCAL STRESS	STRENGTH
BEND.	SHEAR	BUCKL.
MPA	MPA	ULTIMATE
		COLUMN
		MPA

1	175.59	35.82	-	-	-
---	--------	-------	---	---	---



2	141.97	33.83	-	-	-
3	185.46	39.88	-	-	-
4	179.73	40.49	-	-	-

-----FACTOR OF SAFETY-----  
AT DESIGN LOAD

SEG	PLATE BUCKLING	STIFFENER- SHEAR	STIFFENED PLATE- COMP+BEND	ULTIMATE	TENSION+BEND.
1	-	3.12	1.06	-	-
2	-	3.30	1.31	-	-
3	-	2.80	1.00	-	-
4	-	2.76	1.04	-	-

PRINTED REPORT NO. 12 - SIDE AND BOTTOM FRAMES

FRAME SPACING, M 2.44

SEGMENT GEOMETRY

SEG	NODE YUPR	COORD, M ZUPR	YLWR	ZLWR	SCND. LOAD, M HEAD1	HEAD2
SIDE FRAME						
SEG						
1	4.83	10.09	5.19	7.04	4.27	
2	5.19	7.04	5.20	4.12	7.19	
3	5.20	4.12	3.32	1.19	10.12	
BOT FRAME						
SEG						
1	3.32	1.19	2.51	0.82	10.49	
2	2.51	0.82	0.00	0.00	11.31	

SEGMENT SCANTLINGS

-----SCANTLINGS OF STIFFENED PLATES-----							
SEG	STIFFENERS		CATLG NO	PLATE TK, MM	SPAN M		
	MMXMMXMM/MM						
SIDE FRAME							
SEG							
1	*R 303.276X	101.600X	7.874/	11.684	57.	6.3500	255.82
2	*R 354.838X	152.400X	9.398/	13.462	78.	6.3500	243.83
3	*R 455.930X	279.400X	10.922/	16.510	129.	6.3500	289.76
BOT FRAME							
SEG							
1	*R 126.746X	50.800X	4.572/	7.874	9.	9.5250	74.02
2	*R 304.038X	177.800X	7.874/	13.462	71.	10.3187	220.26

NOTE: \*R STANDS FOR ROLLED SHAPE

SEGMENT PROPERTIES

-----PROPERTIES OF STIFFENED PLATES-----							
SEG	AREA		N.A. TO PLATE MM	SEC MOD		WT/M N/M	SMEAR RATIO
	TOTAL CM2	SHEAR CM2		PLATE CM3	FLANGE CM3		
SIDE FRAME							
SEG							
1	191.16	25.30	147.20	582.25	492.24	1468.49	0.23
2	209.29	35.21	196.81	789.03	873.18	1607.75	0.35
3	252.19	52.29	298.94	1287.23	2139.51	1937.33	0.63
BOT FRAME							
SEG							
1	242.32	25.95	29.40	287.22	73.58	1861.51	0.04
2	299.81	101.62	132.09	1316.30	888.32	2303.09	0.19

STRESS AND FACTOR OF SAFETY

SEG	STRESS, MPA		FOS	
	BENDING	SHEAR	BENDING	SHEAR
SIDE FRAME				
SEG				
1	369.62	63.47	1.03	3.58
2	364.26	73.27	1.04	3.11

3	373.19	82.48	1.02	2.76
BOT FRAME				
SEG				
1	346.28	173.24	1.10	1.31
2	365.16	141.94	1.04	1.60

PRINTED REPORT NO. 13 - DECK BEAMS

FRAME SPACING, M 2.44

SEGMENT GEOMETRY

-----NODE COORD, M -----		-----SCND. LOAD, M --				
SEG	YIB	ZIB	YOB	ZOB	HEAD1	HEAD2
WET DECK						
SEG						
1	0.00	10.09	1.54	10.09	2.58	
2	1.54	10.09	4.83	10.09	2.58	
DECK NO. 1						
SEG						
1	0.00	7.04	1.54	7.04	0.84	
2	1.54	7.04	5.19	7.04	0.84	
DECK NO. 2						
SEG						
1	0.00	4.12	1.54	4.12	0.84	
2	1.54	4.12	5.20	4.12	0.84	
DECK NO. 3						
SEG						
1	0.00	1.19	1.54	1.19	0.84	
2	1.54	1.19	3.32	1.19	0.84	

SEGMENT SCANTLINGS

-----SCANTLINGS OF STIFFENED PLATES-----								
STIFFENERS				CATLG	PLATE	SPAN		
-----MMXMMXMM/MM-----				NO	TK, MM	M		
WET DECK								
SEG								
1	*R	201.422X	76.200X	6.350/	9.398	26.	9.5250	256.79
2	*R	226.822X	76.200X	6.350/	9.398	30.	9.5250	274.10
DECK NO. 1								
SEG								
1	*R	152.146X	50.800X	4.572/	7.874	10.	6.3500	256.79
2	*R	176.530X	76.200X	4.572/	6.350	14.	6.3500	304.36
DECK NO. 2								
SEG								
1	*R	152.146X	50.800X	4.572/	7.874	10.	6.3500	256.79
2	*R	176.530X	76.200X	4.572/	6.350	14.	6.3500	304.87
DECK NO. 3								
SEG								
1	*R	152.146X	50.800X	4.572/	7.874	10.	6.3500	256.79
2	*R	76.251X	50.800X	3.175/	4.775	1.	6.3500	148.33
NOTE: *R STANDS FOR ROLLED SHAPE								

SEGMENT PROPERTIES

-----PROPERTIES OF STIFFENED PLATES-----							
-----AREA-----		N.A. TO		-----SEC MOD-----		SMEAR	
SEG	TOTAL	SHEAR	PLATE	PLATE	FLANGE	WT/M	RATIO
	CM2	CM2	MM	CM3	CM3	N/M	
WET DECK							
SEG							
1	252.45	13.99	57.25	638.49	224.14	1939.32	0.09
2	254.06	15.60	64.69	719.53	257.08	1951.71	0.09
DECK NO. 1							
SEG							
1	166.13	7.61	48.02	221.85	90.02	1276.19	0.07
2	168.13	8.65	60.47	266.32	125.08	1291.56	0.09
DECK NO. 2							
SEG							
1	166.13	7.61	48.02	221.85	90.02	1276.19	0.07
2	168.13	8.65	60.47	266.32	125.08	1291.56	0.09

