

GPS WEEK ROLL-OVER AND Y2K COMPLIANCE FOR NBS-TYPE RECEIVERS, AND ABSOLUTE CALIBRATION OF THE NIST PRIMARY RECEIVER*

M. Weiss, V. Zhang
National Institute of Standards and Technology
325 Broadway, Boulder, CO 80303

E. Powers
U.S. Naval Observatory

R. Loiler
Allan Osborne Associates

Abstract

The NBS-type receiver software was modified to account for both the GPS end-of-week crossover and for the Y2K event. Receivers using this software were tested by personnel from the National Institute of Standards and Technology and the U.S. Naval Observatory using a simulator at the Naval Research Laboratory. An independent test was performed by a private company. The software now appears to be fully compliant with requirements for both the GPS week roll-over and the Y2K events. Since the NBS-type receivers are still the predominant receiver for time transfer among laboratories which generate International Atomic Time, this receiver was given significant attention. In the process, an absolute calibration of the delay through the primary NIST GPS common-view receiver was completed. This calibration agrees within its 2.8 ns uncertainty both with the value from an estimate in June 1986, which has been used continuously since then, and with an absolute calibration in April of 1987.

GPS WEEK ROLL-OVER AND Y2K COMPLIANCE

Receivers of signals from Global Positioning System satellites decode time and date information from the satellite's 50 Hz bit stream [1]. The date is transmitted as a 10-bit week number plus the second of the week. With 10 bits, the week value can range from 0 to 1023. Week 1023 corresponds to the week ending August 21, 1999. The week starting August 22, 1999 will be broadcast as week 0 again. This event is called the GPS week roll-over. NBS-type receivers are those patterned after the time transfer receiver completed by the National Bureau of Standards (NBS, now called the National Institute of Standards or NIST) in the early 1980's. Software for these receivers is usually written by personnel of NIST.

*Contribution of U.S. Government not subject to copyright.

Report Documentation Page

*Form Approved
OMB No. 0704-0188*

Public reporting burden for the collection of information is estimated to average 1 hour per response, including the time for reviewing instructions, searching existing data sources, gathering and maintaining the data needed, and completing and reviewing the collection of information. Send comments regarding this burden estimate or any other aspect of this collection of information, including suggestions for reducing this burden, to Washington Headquarters Services, Directorate for Information Operations and Reports, 1215 Jefferson Davis Highway, Suite 1204, Arlington VA 22202-4302. Respondents should be aware that notwithstanding any other provision of law, no person shall be subject to a penalty for failing to comply with a collection of information if it does not display a currently valid OMB control number.

1. REPORT DATE DEC 1998	2. REPORT TYPE	3. DATES COVERED 00-00-1998 to 00-00-1998			
4. TITLE AND SUBTITLE GPS Week Roll-Over and Y2K Compliance for NBS-Type Receivers and Absolute Calibration of the NIST Primary Receiver		5a. CONTRACT NUMBER			
		5b. GRANT NUMBER			
		5c. PROGRAM ELEMENT NUMBER			
6. AUTHOR(S)		5d. PROJECT NUMBER			
		5e. TASK NUMBER			
		5f. WORK UNIT NUMBER			
7. PERFORMING ORGANIZATION NAME(S) AND ADDRESS(ES) National Institute of Standards and Technology, 325 Broadway, Boulder, CO, 80303		8. PERFORMING ORGANIZATION REPORT NUMBER			
9. SPONSORING/MONITORING AGENCY NAME(S) AND ADDRESS(ES)		10. SPONSOR/MONITOR'S ACRONYM(S)			
		11. SPONSOR/MONITOR'S REPORT NUMBER(S)			
12. DISTRIBUTION/AVAILABILITY STATEMENT Approved for public release; distribution unlimited					
13. SUPPLEMENTARY NOTES See also ADA415578. 30th Annual Precise Time and Time Interval (PTTI) Systems and Applications Meeting, Reston, VA, 1-3 Dec 1998					
14. ABSTRACT see report					
15. SUBJECT TERMS					
16. SECURITY CLASSIFICATION OF:			17. LIMITATION OF ABSTRACT Same as Report (SAR)	18. NUMBER OF PAGES 8	19a. NAME OF RESPONSIBLE PERSON
a. REPORT unclassified	b. ABSTRACT unclassified	c. THIS PAGE unclassified			

The GPS week number is used by the NBS-type receivers to synchronize the receiver clock. Unless the software is upgraded, NBS-type GPS receivers will not be able to update the clock after the GPS roll-over. The receiver clock will walk off, unless it is manually updated, resulting in incorrect time-tagging, shortened tracks, and loss of track.

NBS-type receivers keep track of the year using the two low-order digits, the ones and tens digits, since they can be held in one byte. At and after the year 2000, the routine in the receiver which converts the calendar date to the modified Julian day (MJD) will fail without an upgrade. Since this conversion is used as a test to see if the year was entered correctly, the receiver will also fail to back up the current date to its internal fail-safe clock. Consequently, the MJD will never be set correctly, and the date will be lost if power is cycled. If power is not cycled, the MJD will be incremented properly at the end of each day. Thus, users may not notice a problem until the receiver is turned off and on again.

An update which complies with both the GPS week roll-over and the roll over of the low-order digits of the calendar year at the year 2000, the so-called Y2K event, has been created. The GPS week roll-over software update, version V9802, for NBS-type receivers was tested at the Naval Research Laboratory (NRL) in February, 1998 [2]. V9802 was also tested by Allen Osborne Associates (AOA) in May, 1998. The test showed that V9802 handles the GPS week roll-over properly [3]. However, V9802 failed to set the receiver clock correctly when the receiver was powered up after the year 2000.

V9802 was modified to create the second version of software update, V9806. This version was tested by AOA in June of 1998, and passed the week roll-over and Y2K power-cycling tests without problems. Version V9806 was also tested at NRL using a GPS simulator [2] on August 25, 1998. The software was installed in a NIST GPS receiver (serial number NIST57, model TTR-5). The purpose of the test was to verify that the NBS-type GPS receiver with the software update will operate properly before and after the following events which were simulated during the test:

- (1) GPS week roll-over
- (2) Year 2000
- (3) Leap year after year 2000.

For the GPS week roll-over and year 2000 tests, the following were tested for the dates before and after the event:

- if the receiver can correctly set its clock (MJD, date, time) when powered up,
- if the receiver can track GPS satellites according to the schedule and lock on the GPS signal,
- if the receiver can synchronize its clock when locked on the GPS signal (when the receiver clock is off by less than 15 minutes).

For the leap year test, we observed for the date from February 28 to March 1:

- if the receiver can correctly set its clock (MJD, date, time) when powered up on February 29 of year 2000 and year 2004,
- if the receiver clock (MJD, date, time) is correct during the track and in the idle state for the leap years (year 2000 and year 2004) and non-leap years (year 1999 and year 2001),
- if the receiver can track GPS satellites according to schedule and lock on the GPS signal,
- if the receiver can synchronize its clock when locked on the GPS signal (when the receiver clock is off by less than 15 minutes).

The tests have shown, with V9806:

- the receiver clock (MJD, date, time) is set correctly when powered up before and after the roll-over, before and after the year 2000 and on February 29 after year 2000,
- the receiver has no problem tracking GPS satellites and locking on the GPS signal,
- the receiver can synchronize its clock when locked on the GPS signal (when the receiver clock is off by less than 15 minutes),
- the receiver clock is correct during tracks and in the idle state for the leap years and non-leap years.

The test did reveal a few imperfections in V9806, minor things used for housekeeping purposes. Some of the imperfections were corrected to generate the new version V9809.

The test results indicate that the software update, V9809, is fully compliant with the requirements for both the GPS week roll-over and year 2000.

CALIBRATION OF THE NIST PRIMARY GPS RECEIVER

The receiver NIST57 was calibrated for its total timing delay in addition to being used to test the software for compliance with events as above. This calibration was transferred to the NIST reference receiver NBS10. The NIST57 was calibrated against the primary receiver, NBS10 from August 3, 1998 to August 13, 1998, before it was shipped to Naval Research Laboratory (NRL). At NRL, the NIST57 was calibrated using a simulator on August 25, 1998 [2]. The NIST57 was then returned to NIST and re-calibrated against NBS10 from September 6, 1998 to September 16, 1998.

During the calibration at NIST, the antenna for NIST57 was positioned in a location close to the antenna of NBS10. The two receivers were set up for a common-clock calibration [4,5,6,7]: they were given the same track schedule; the 5 MHz reference frequency and the local 1 pps (with known 1 pps cable delays) were derived from the same source, UTC(NIST) in this case. The receiver measures reference clock time minus GPS time (REF-GPS) via individual satellites [8]. To determine the relative

delay, NBS10 - NIST57, values of REF-GPS were differenced for matching satellites at the mid-point of full length tracks (track length of 780 s). Because both NBS10 and NIST57 were driven by the same clock, the REF-GPS differences yielded the differential receiver delays, once known cable delays were accounted for. The NIST57 was set up in the same condition before and after the trip to NRL, for closure.

During the simulator calibration at NRL, the C/A code at L1 frequency from the simulator was injected into the low-noise amplifier (LNA) of the NIST57's antenna/down converter, as indicated in block form in Figure 1. The signal power injected into the LNA was comparable to the GPS signal power received by the antenna. The 5 MHz reference frequency for NIST57 was taken from the same source as used by the simulator. The local 1 pps signal for NIST57 was generated by the simulator. The timing relationship between the local 1 pps signal for NIST57 and the C/A code transition for REF-GPS was estimated before the calibration.

The NIST57 took three standard 780 s tracks during the calibration. The third track was made after power-down/power-up of the receiver. Because the third track showed a warm-up trend with the measurements converging to the value before the power-down, only the mid-point REF-GPS value of the first two 780-second tracks were used to determine the absolute receiver delay. Since we know the simulator's REF-GPS offset from its 1 pps signal, the absolute NIST57 receiver delay can be obtained by:

$$\text{Simulator - NIST57} = [(\text{REF-GPS})_{\text{simulator}} - (\text{REF-GPS})_{\text{NIST57}}] + \text{cable delays.}$$

With the NIST57 absolute receiver delay calibrated by the simulator and relative receiver delay calibrated by NBS10, the NBS10 receiver delay of this calibration is given as an offset from the current NBS10 delay by:

$$(\text{NBS10 delay})_{\text{Cal}} = \text{NBS10 delay} + [(\text{Simulator - NIST57}) - (\text{NBS10 - NIST57})].$$

The calibration results are presented in Table I. The comparisons between the traveling receiver, NIST57, and the primary receiver, NBS10, are in rows 2-3 with the number, N , of measurements, the mean, μ , of these measurements, the formal standard deviation σ , and the standard deviation of mean σ/\sqrt{N} . The noise type of each of the calibrations was determined to be consistent with a white phase noise model. Hence, the standard deviation of the mean is a valid statistic. Row 4 gives the value used for the transfer, 54.8 ns.

Below the transfer numbers Table I gives the values for the calibration with the simulator in rows 5-6. NIST57 was calibrated to have a delay of 56.2 ns. The difference of the NIST57 calibration, 56.2 ns, minus the transfer calibration of 54.8 ns gives the calibrated offset of NBS10, 1.4 ns. Adding this to the current receiver delay of 53 ns for NBS10 gives the calibrated delay of 54.4 ns.

The uncertainty of this NBS10 receiver delay calibration is about 2.8 ns, which is estimated from the uncertainty of the relative receiver calibration and the uncertainty of the absolute receiver calibration. The uncertainty of the relative receiver delay calibration is 2.0 ns, which mainly comes from the delay change of the antenna electronics as a function of the outdoor temperature change. The uncertainty of the absolute receiver delay calibration is 2.0 ns, which is the error in estimating REF-GPS of the simulator.

The historical values of the NBS10 delay are illustrated in Table II. The current value of the NBS10 receiver delay, 53 ns, was estimated in June, 1986. In April, 1987, the NBS10 receiver delay was calibrated via the absolute calibration of a traveling receiver at the United States Naval Observatory (USNO) with a calibrator of NRL. The NBS10 receiver delay of that calibration was 57 ns with an uncertainty of 5 ns. It was decided not to change the delay in NBS10 because the +4 ns delay change was within the uncertainty of the calibration. The NBS10 receiver delay of this calibration differs from the previous two calibrations by +1.4 ns and -2.6 ns, respectively. Because these values are within the uncertainty of this calibration, we conclude there is no significant change in the NBS10 receiver delay since June, 1986. Since the NIST receiver is part of the network of common-view GPS receivers used for generating TAI, this result implies that the delay used among the receivers in this network is consistent with the capabilities of current calibration equipment. NIST has verified the constancy of this delay at the level of a few ns over 12 years by constant inter-comparisons among three receivers. Some of the variations in these receivers are shown to be of order a few ns over the past 6 years in [9].

TABLE I: AUGUST- SEPTEMBER 1998 CALIBRATION

Calibrations at NIST: NBS10 - NIST57	N	μ (ns)	σ (ns)	σ/\sqrt{N} (ns)
Before trip (8/3/98 - 8/13/98)	526	54.9	2.89	0.13
After trip: (9/6/98 - 9/16/98)	505	54.7	2.57	0.11
Mean value		54.8		
Simulator Calibration: Simulator - NIST57	N	μ (ns)	Uncertainty (ns)	
NRL: (8/25/98)	2	56.2	2.0	
Simulator - NBS10 Calibration	1.4 ns		2.8	
NBS10 receiver delay (9/98)	54.4 ns		2.8	

TABLE II: HISTORICAL CALIBRATIONS

Calibration	Value (ns)	uncertainty (ns)
June 1986, Theoretical Estimate — Used Continuously Since Then	53	unknown
April 1987, at USNO with NRL Calibrator	57	5

REFERENCES

- [1] Interface Control Document, ICD-GPS-200, available from Arinc Research Corp., 11770 Warner Ave, Suite 210, Fountain Valley, CA 92708.
- [2] E.D. Powers, M. Miranian, J.D. White, J. Brad, "Absolute Time Error Calibration of GPS Receivers Using Advanced GPS Simulators," *Proc. 29th Precise Time and Time Interval (PTTI) Meeting*, pp 193-198, 1997.
- [3] This test was done with an Estel 7200 satellite simulator. Trade names are reported for completeness. No endorsement by NIST is implied.
- [4] J.A. Buisson, O.J. Oaks, and M.J. Lister, "Remote Calibration and Time Synchronization (R-CATS) Between Major European Time Observatories and the U.S. Naval Observatory Using GPS," *Proc. 17th PTTI*, pp.201-222, 1985.
- [5] W. Lewandowski, M.A. Weiss, and D. Davis, "A Calibration of GPS Equipment at Time and Frequency Laboratories in the USA and Europe," *Proc. 18th PTTI*, pp. 265-279, 1986, [also in *Metrologia*, 24, pp. 181-186, 1987].
- [6] M.A. Weiss, and D. Davis, "A Calibration of GPS Equipment in Japan," *Proc. 20th PTTI*, pp. 101-106, 1988.
- [7] W. Lewandowski, "Determination of the Differential Time Correction Between GPS Time Receivers Located at the Observatoire de Paris, the Observatoire de la Côte d'Azur and the Technical University of Graz," *Rapport BIPM — 91/6*, 1991.
- [8] D.W. Allan, C. Thomas, "Technical Directives for Standardization of GPS Time Receiver Software," *Metrologia*, 1994, 31, pp.69-79.

- [9] M.A. Weiss, V. Zhang, L. Nelson, V. Hanns, M.G.L. Regalado, "Delay Variations in Some Timing Receivers," *Proc. 1997 IEEE International Frequency Symposium*, pp.304-312.

ACKNOWLEDGMENTS

Special thanks to Joe White and the Naval Research Laboratory for assistance with and use of their calibration equipment.

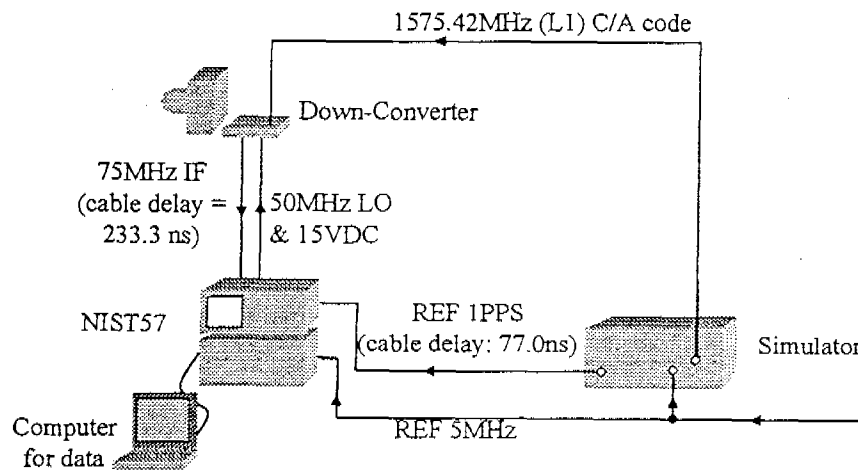

Figure 1. Test setup for the absolute calibration of NIST57.

Questions and Answers

ROBERT M. GRAHAM (Sandia National Laboratories): During the simulated end-of-week rollover tests, why was the GPS operational status (or rollover period) monitored for two minutes before the rollover and only 12 minutes after the rollover?

MARC WEISS (NIST): The GPS receiver is limited to accepting a programmed time change - via the simulator - of less than 15 minutes. We chose to begin monitoring GPS-operational status two minutes prior to the end-of-week rollover. Therefore, we were limited to the 12 minutes after the rollover.