

Over the next 5 years, many of the programs in our assessment plan to hold design reviews or make a production decisions without demonstrating the level of technology maturity that should have been there before the start of development.

Government Accountability Office on the Department of Defense, 1999

A System Maturity Index for Decision Support in Life Cycle Acquisition

Dr. Brian Sauser
bsauser@stevens.edu

Dr. Jose Emmanuel Ramirez-Marquez
jmarquez@stevens.edu

Stevens Institute of Technology
School of Systems and Enterprises
Castle Point on Hudson
Hoboken, NJ 07030

Report Documentation Page

Form Approved
OMB No. 0704-0188

Public reporting burden for the collection of information is estimated to average 1 hour per response, including the time for reviewing instructions, searching existing data sources, gathering and maintaining the data needed, and completing and reviewing the collection of information. Send comments regarding this burden estimate or any other aspect of this collection of information, including suggestions for reducing this burden, to Washington Headquarters Services, Directorate for Information Operations and Reports, 1215 Jefferson Davis Highway, Suite 1204, Arlington VA 22202-4302. Respondents should be aware that notwithstanding any other provision of law, no person shall be subject to a penalty for failing to comply with a collection of information if it does not display a currently valid OMB control number.

1. REPORT DATE SEP 2007		2. REPORT TYPE		3. DATES COVERED 00-00-2007 to 00-00-2007	
4. TITLE AND SUBTITLE A System Maturity Index for Decision Support in Life Cycle Acquisition				5a. CONTRACT NUMBER	
				5b. GRANT NUMBER	
				5c. PROGRAM ELEMENT NUMBER	
6. AUTHOR(S)				5d. PROJECT NUMBER	
				5e. TASK NUMBER	
				5f. WORK UNIT NUMBER	
7. PERFORMING ORGANIZATION NAME(S) AND ADDRESS(ES) Stevens Institute of Technology, School of Systems and Enterprises, Castle Point on Hudson, Hoboken, NJ, 07030				8. PERFORMING ORGANIZATION REPORT NUMBER	
9. SPONSORING/MONITORING AGENCY NAME(S) AND ADDRESS(ES)				10. SPONSOR/MONITOR'S ACRONYM(S)	
				11. SPONSOR/MONITOR'S REPORT NUMBER(S)	
12. DISTRIBUTION/AVAILABILITY STATEMENT Approved for public release; distribution unlimited					
13. SUPPLEMENTARY NOTES See also ADM002182. Presented at the AFRL Technology Maturity Conference held in Virginia Beach, VA on 11-13 September 2007.					
14. ABSTRACT					
15. SUBJECT TERMS					
16. SECURITY CLASSIFICATION OF:			17. LIMITATION OF ABSTRACT Same as Report (SAR)	18. NUMBER OF PAGES 42	19a. NAME OF RESPONSIBLE PERSON
a. REPORT unclassified	b. ABSTRACT unclassified	c. THIS PAGE unclassified			

Abstract

In the National Aeronautics and Space Administration (NASA) and the Department of Defense (DoD) the Technology Readiness Level (TRL) scale is a measure of maturity of an individual technology, with a view towards operational use in a system context. **A comprehensive set of concerns becomes relevant when this metric is abstracted from an individual technology to a system context, which may involve interplay among multiple technologies that are integrated through a systems engineering process.** This research proposes the development of a system-focused approach for managing system development and making effective and efficient decisions during a systems engineering process. This research will present **a System Readiness Level (SRL) index that incorporates both the current TRL scale and the concept of an Integration Readiness Level (IRL) and provide a method for determining current and future readiness of a system to determine its potential position in the systems engineering process.**

What's Missing in TRL?

- **A complete representation of the (difficulty of) integration of the subject technology or subsystems into an operational system** (Dowling and Pardoe, 2005, Mankins, 2002, Meystel et al., 2003, Smith, 2005, Valerdi and Kohl, 2004),
- **The uncertainty that may be expected in moving through the maturation of TRL** (Shishko et al., 2003, Cundiff, 2003, Dowling and Pardoe, 2005, Mankins, 2002, Smith, 2005, Moorehouse, 2001), and
- **Comparative analysis techniques for alternative TRLs** (Cundiff, 2003, Dowling and Pardoe, 2005, Mankins, 2002, Smith, 2005, Valerdi and Kohl, 2004).

“In order to succeed over the longer term, additional methodologies are needed, including those which allow the identification of anticipated uncertainty in planned R&T programs...” (Mankins, 2002)

Other Theories

- Manufacturing Readiness Level (DoD)
 - Used to assess the SE/design process and maturity of a technology's associated manufacturing processes to enable rapid, affordable transition to acquisition programs.
- Integrated Technology Analysis Methodology (ITAM) (Mankins, 2002)
 - Discipline-neutral, quantitative measure of the relative technological challenge inherent in various candidate/competing advanced systems concepts.
- Systems Integration Readiness Level (MoD)
 - System Readiness Levels (*SRLs*) were developed as a tool for projects to assess System Maturity, and to communicate this in a consistent manner.

Ministry of Defence SRL

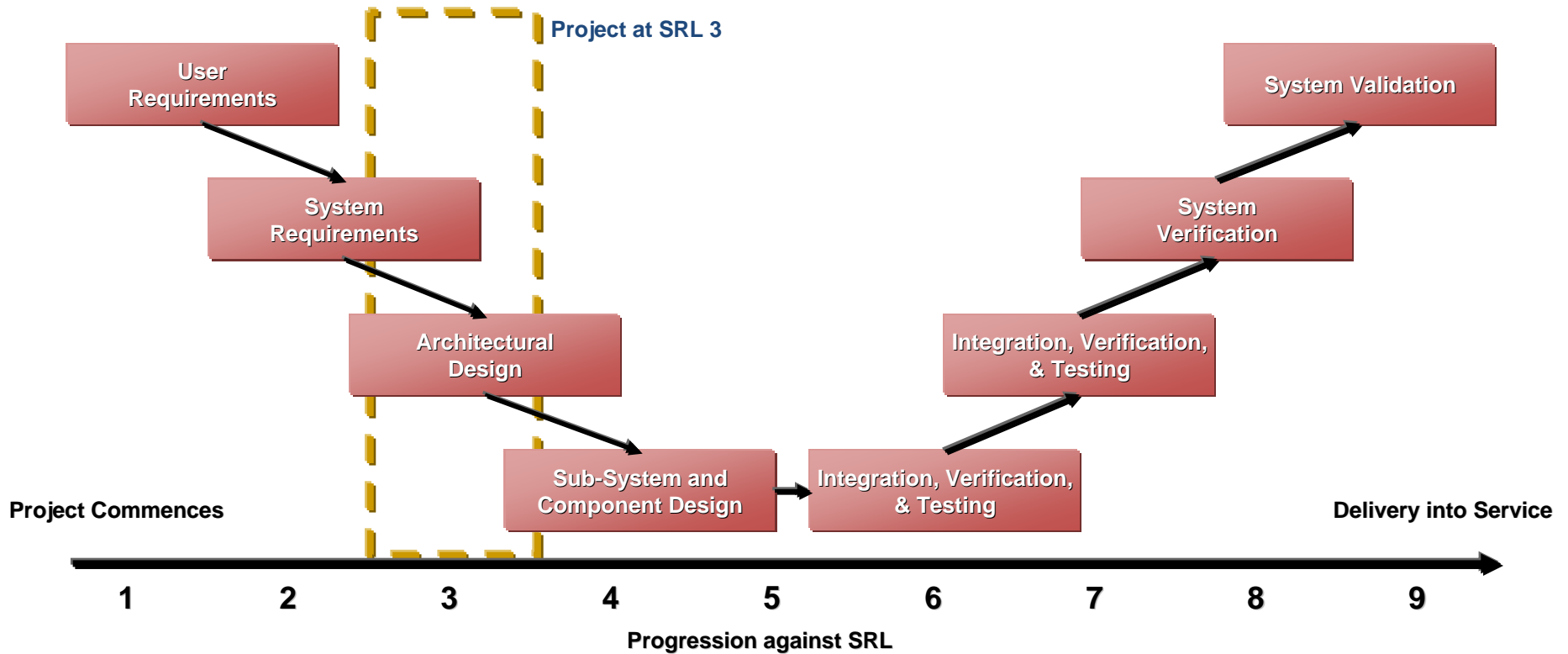

Parallel (*not integrated*) Development

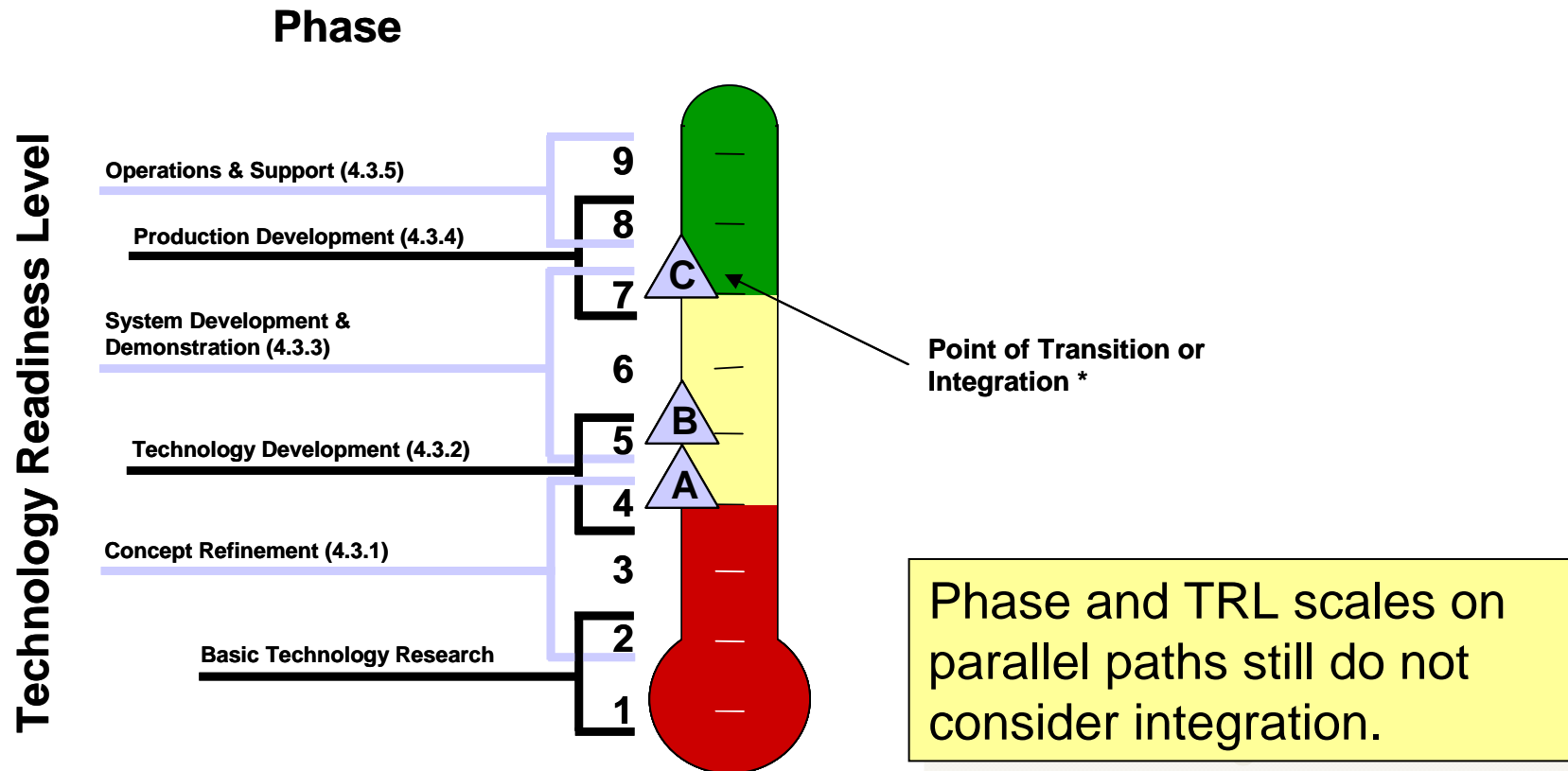

Sausser, B.J., D. Verma, J. Ramirez-Marquez, and R. Gove. (2006). "From TRL to SRL: The Concept of Systems Readiness Levels." *Conference on Systems Engineering Research*, April 7-8. Los Angeles, CA

Why do we need a Systems Readiness Level (SRL)?

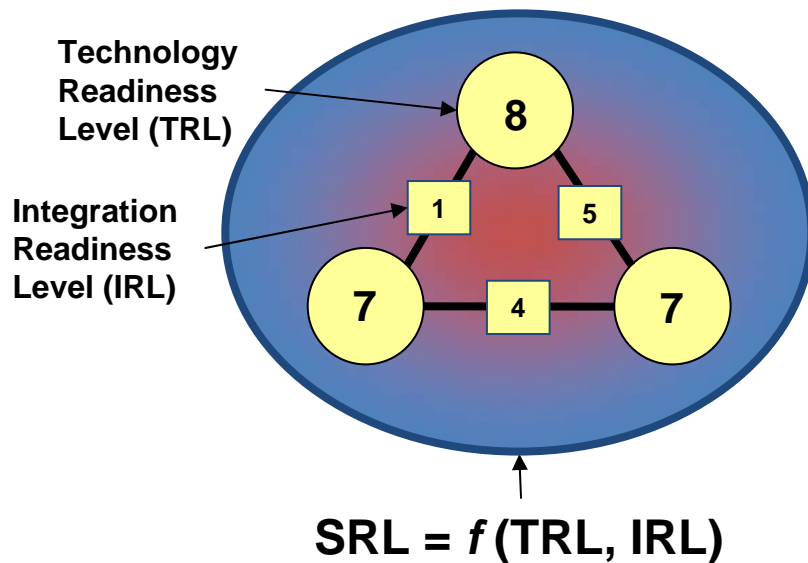

Development of metrics, tool, and methodologies for determining a systems readiness level (SRL) and potential for making efficient and effective life-cycle acquisition and operational decisions. The SRL Model is a function of the individual Technology Readiness Levels (TRL) and their subsequent integration points with other technologies, the Integration Readiness Level (IRL).

– Value Proposition:

- Currently TRL is only a measure of an individual technology
- There is no method for integrating TRLs
- There is no systematic measure of a systems readiness
- Cost and schedule reduction in strategic technology development planning

– Deliverable: Integration of methodologies for strategic roadmap planning that illustrate the timely implementation of capability increments.

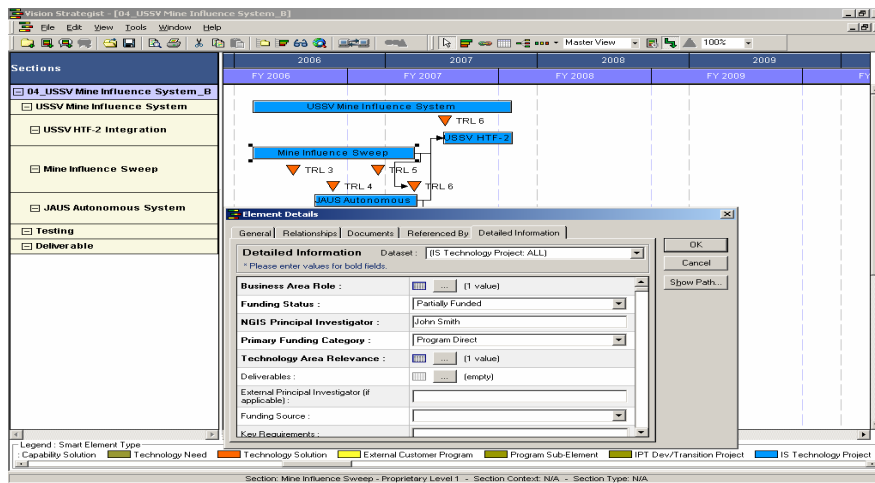

Integration Readiness Level

A systematic measurement of the interfacing of compatible interactions for various technologies and the consistent comparison of the maturity between integration points.

Integration – the combining and coordinating of separate components into a seamless unit – interfacing the compatible interactions of various technologies together

		IRL	Definition
Pragmatic		9	Integration is Mission Proven through successful mission operations.
		8	Actual integration completed and Mission Qualified through test and demonstration, in the system environment.
		7	The integration of technologies has been Verified and Validated with sufficient detail to be actionable.
Syntactic		6	The integrating technologies can Accept, Translate, and Structure Information for its intended application.
		5	There is sufficient Control between technologies necessary to establish, manage, and terminate the integration.
		4	There is sufficient detail in the Quality and Assurance of the integration between technologies.
Semantic		3	There is Compatibility (i.e. common language) between technologies to orderly and efficiently integrate and interact.
		2	There is some level of specificity to characterize the Interaction (i.e. ability to influence) between technologies through their interface.
		1	An Interface between technologies has been identified with sufficient detail to allow characterization of the relationship.

Gove, R. (2007) *Development of an Integration Ontology for Systems Operational Effectiveness*. M.S. Thesis. Stevens Institute of Technology. Hoboken, NJ
 Gove, R., B. Sauser, J. Ramirez-Marquez. (2007). "Integration Maturity Metrics: Development of an Integration Readiness Level." *Acta Astronautica* (under review)

Calculating

System **R**eadiness **L**evel

- *System Alpha** -

System Alpha

Step 1: Determining the TRL and IRL

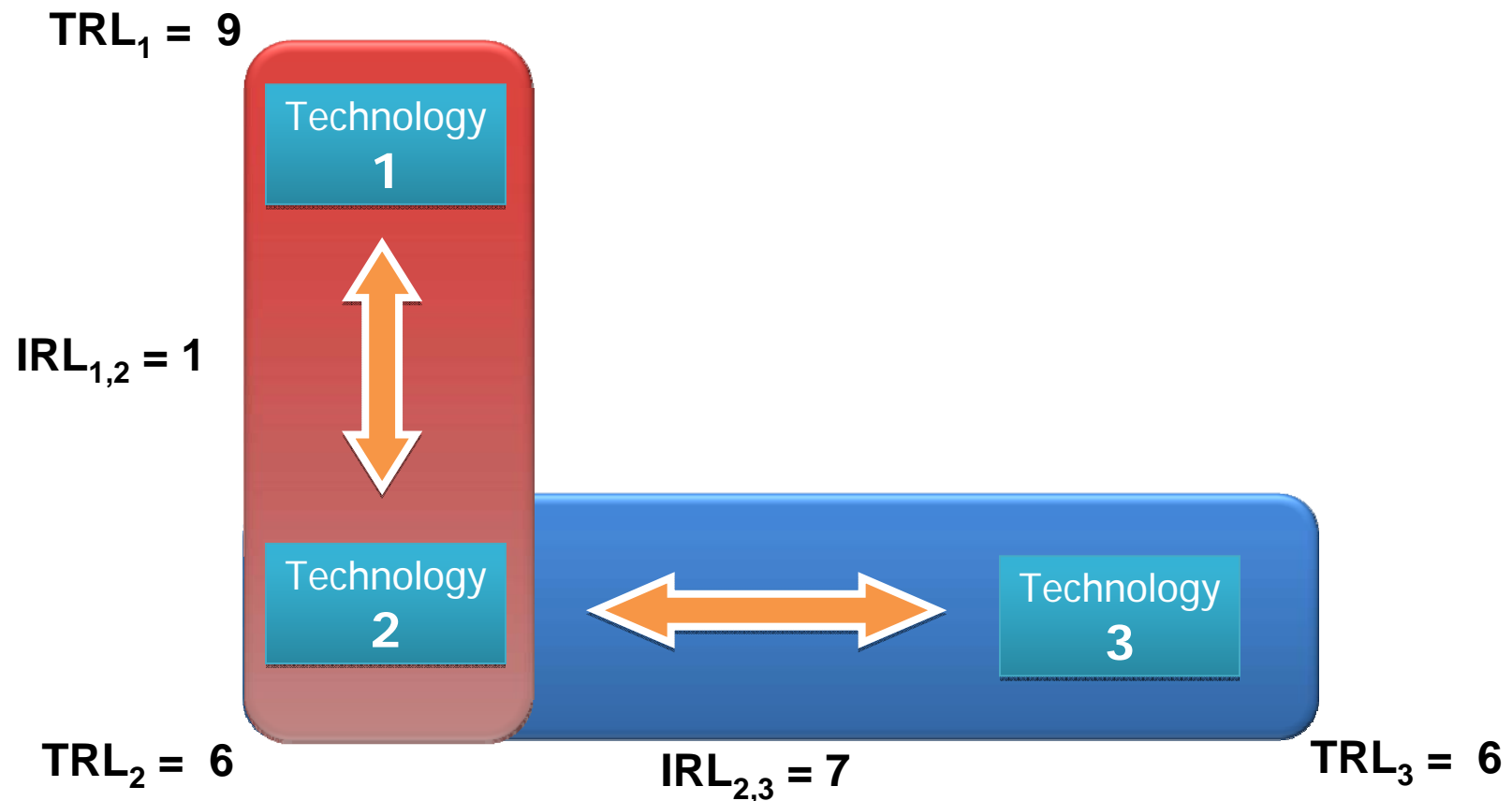

System Alpha – TRL

Step 2: Creating the TRL Matrix

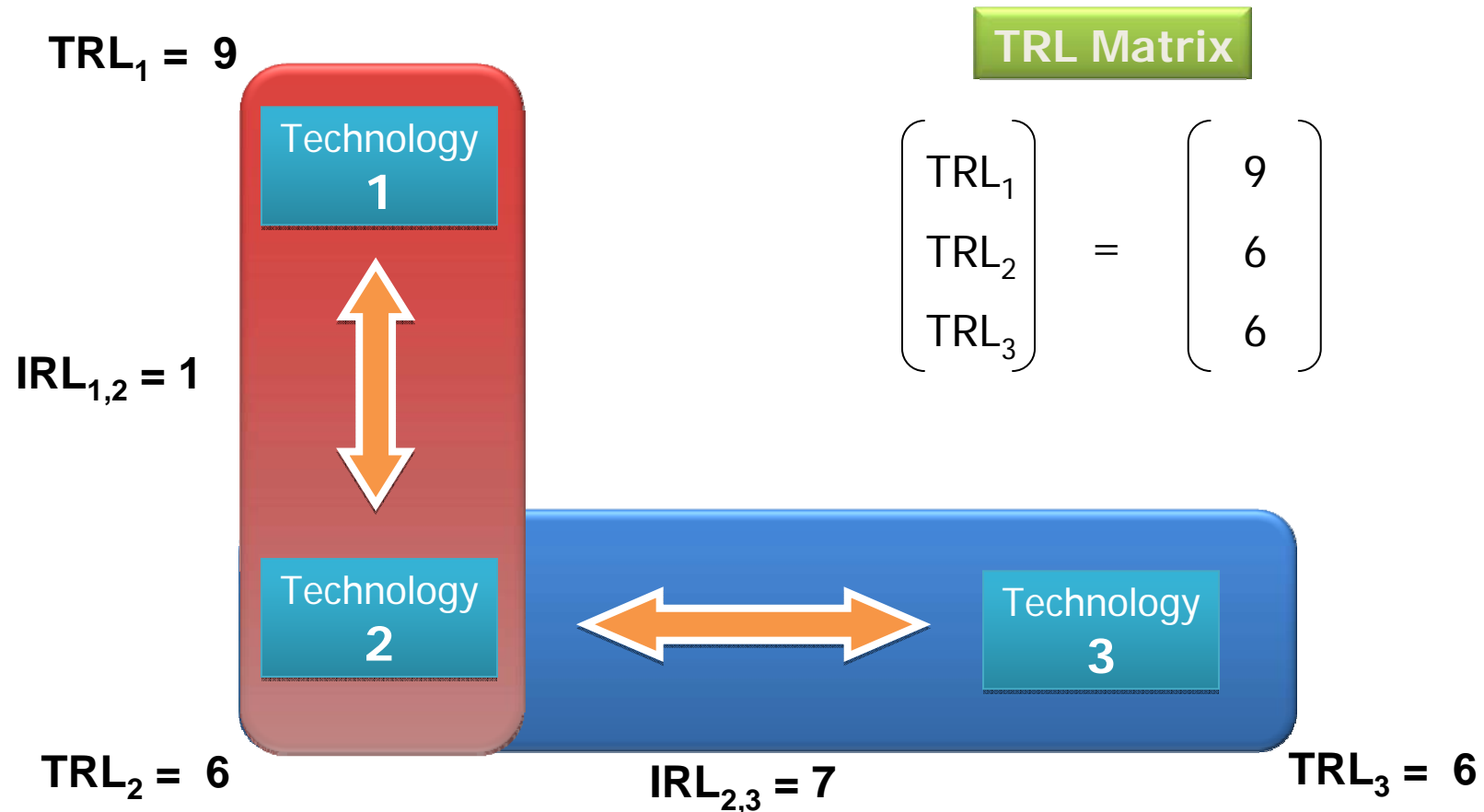

System Alpha – IRL

Step 3: Creating the IRL Matrix

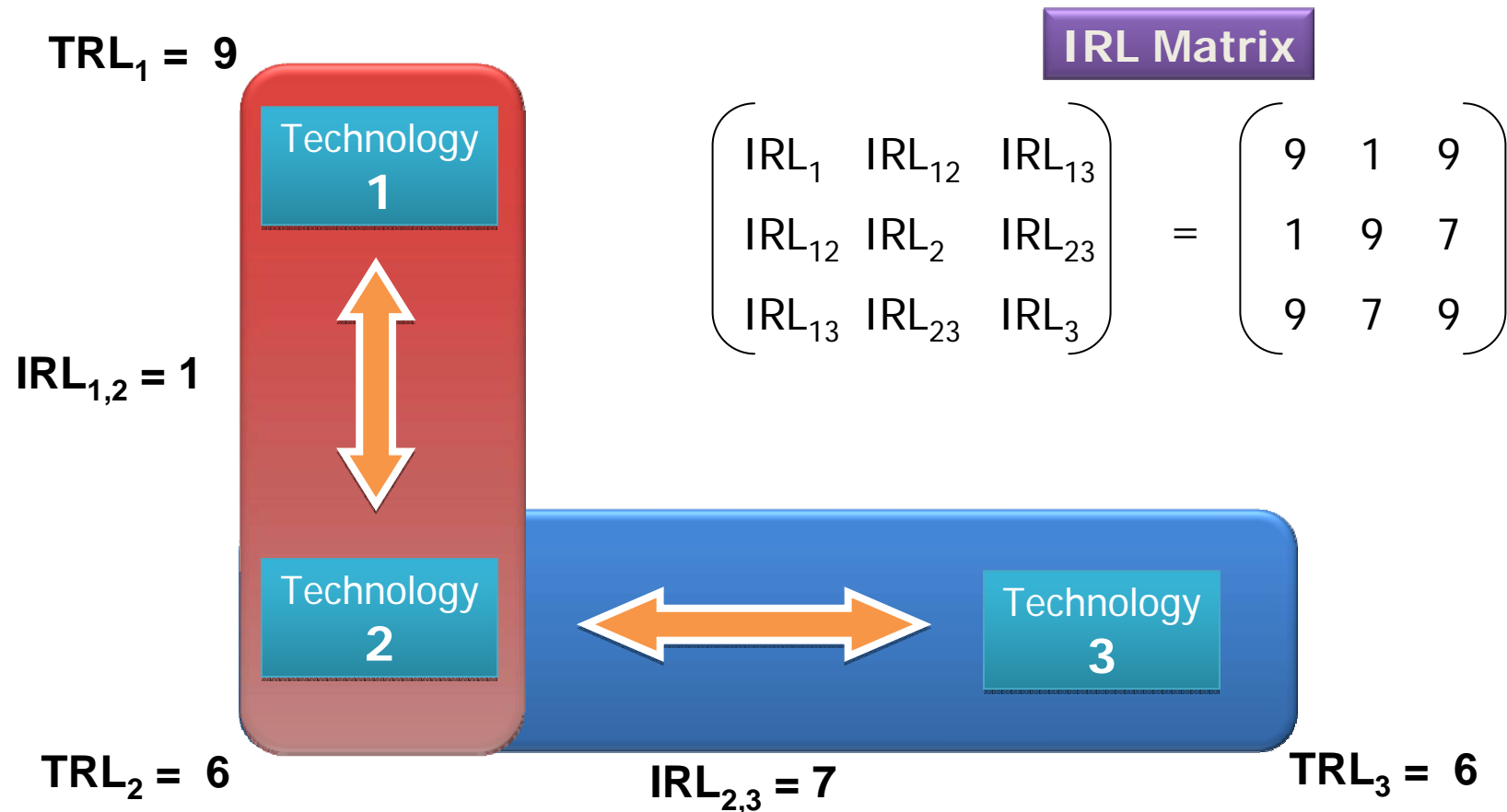

SRL for System Alpha

Step 4: Normalizing the TRLs and IRLs

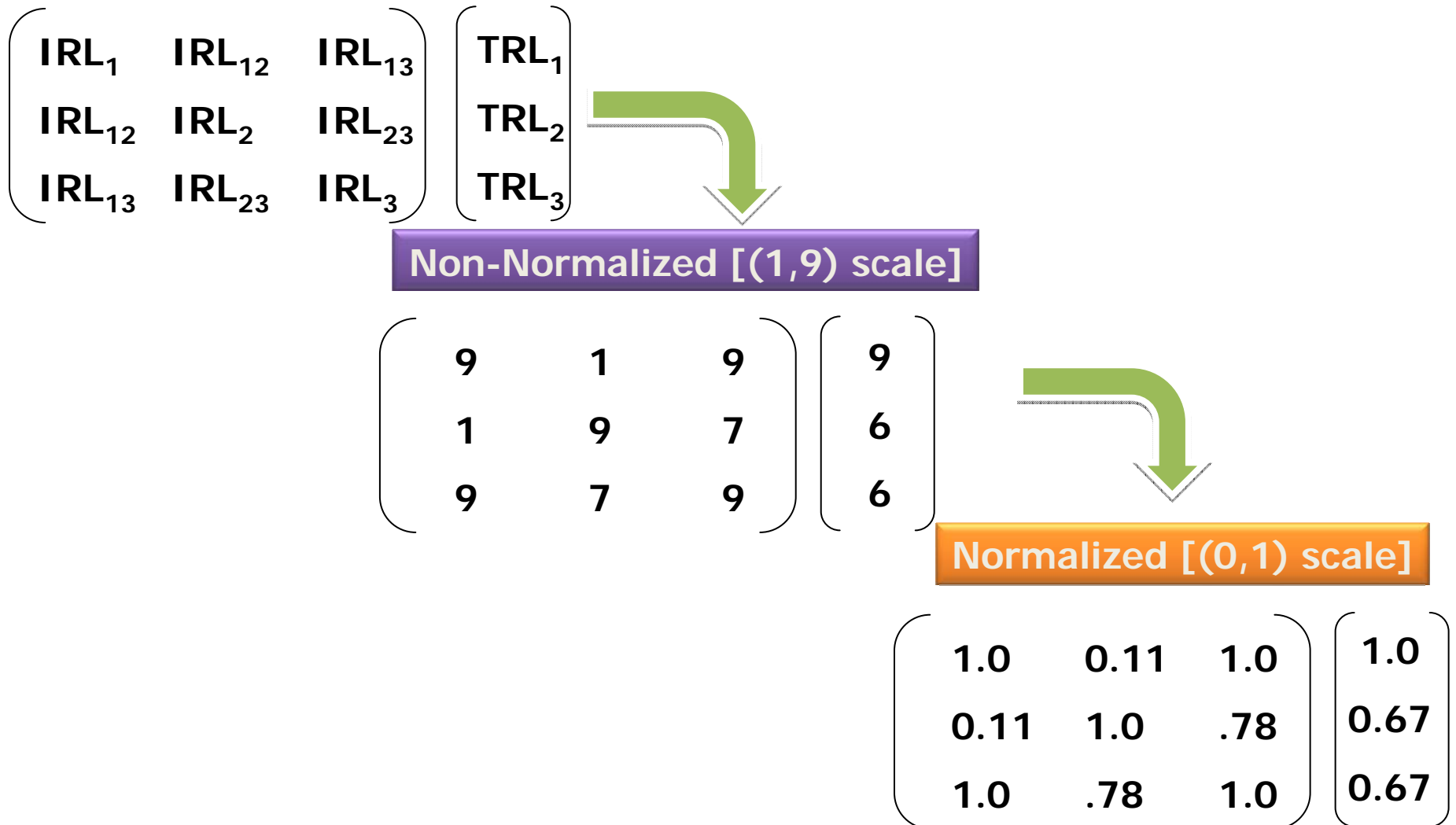

SRL Calculation of System Alpha

Step 5: Calculating the SRLx

$$\text{SRL} = \text{IRL} \times \text{TRL}$$

$$\begin{pmatrix} \text{SRL}_1 & \text{SRL}_2 & \text{SRL}_3 \end{pmatrix} = \begin{pmatrix} \text{IRL}_1 & \text{IRL}_{12} & \text{IRL}_{13} \\ \text{IRL}_{12} & \text{IRL}_2 & \text{IRL}_{23} \\ \text{IRL}_{13} & \text{IRL}_{23} & \text{IRL}_3 \end{pmatrix} \begin{pmatrix} \text{TRL}_1 \\ \text{TRL}_2 \\ \text{TRL}_3 \end{pmatrix}$$

$$\begin{pmatrix} \text{SRL}_1 & \text{SRL}_2 & \text{SRL}_3 \end{pmatrix} = \begin{pmatrix} 1.74 & 1.30 & 2.19 \end{pmatrix} \quad \text{(0,n) scale}$$

Note: SRL_x represents Technology X and its IRLs

SRL for System Alpha

Step 6: Calculating the Composite SRL

$$\left(\text{SRL}_1 \quad \text{SRL}_2 \quad \text{SRL}_3 \right) = \left(1.74 \quad 1.30 \quad 2.19 \right) \quad \text{(0,n) scale}$$

$$\left(\text{SRL}_1 \quad \text{SRL}_2 \quad \text{SRL}_3 \right) = \left(0.58 \quad 0.43 \quad 0.73 \right) \quad \text{(0,1) scale}$$

$$\begin{aligned} \text{Composite SRL} &= 1/3 (0.58 + 0.43 + 0.73) \\ &= \boxed{0.58} \end{aligned}$$

SRL Calculator with System Alpha

$TRL_1 = 9$

Technology 1

1

↑↓

Technology 2

$TRL_2 = 6$

$IRL_{1,2} = 1$

Technology 3

↔

$IRL_{2,3} = 7$

$TRL_3 = 6$

SRL Calculator

IMPORTANT

- Enter TRL and IRL values (1 to 9 scale) in the above boxes only
- Leave **BLANKs** for non-existent TRLs and IRLs connecting them to any other TRL
- Enter level 9 for IRLs that don't exist between existing TRLs

Non - Normalized									
IRL	A	B	C	D	TRL	A	B	C	D
A	9	0	1	9	9	A	SRL _A		
B	0	9	0	0	0	B	SRL _B		
C	1	0	9	7	6	C	SRL _C		
D	9	0	7	9	6	D	SRL _D		

Normalized									
IRL	A	B	C	D	TRL	A	B	C	D
A	1.00	0.00	0.11	1.00	1.00	A	1.74		
B	0.00	1.00	0.00	0.00	0.00	B	0.00		
C	0.11	0.00	1.00	0.78	0.67	C	1.30		
D	1.00	0.00	0.78	1.00	0.67	D	2.19		

Composite SRL = 0.58

© 2007 Stevens Institute of Technology

System Life Cycle of System Alpha

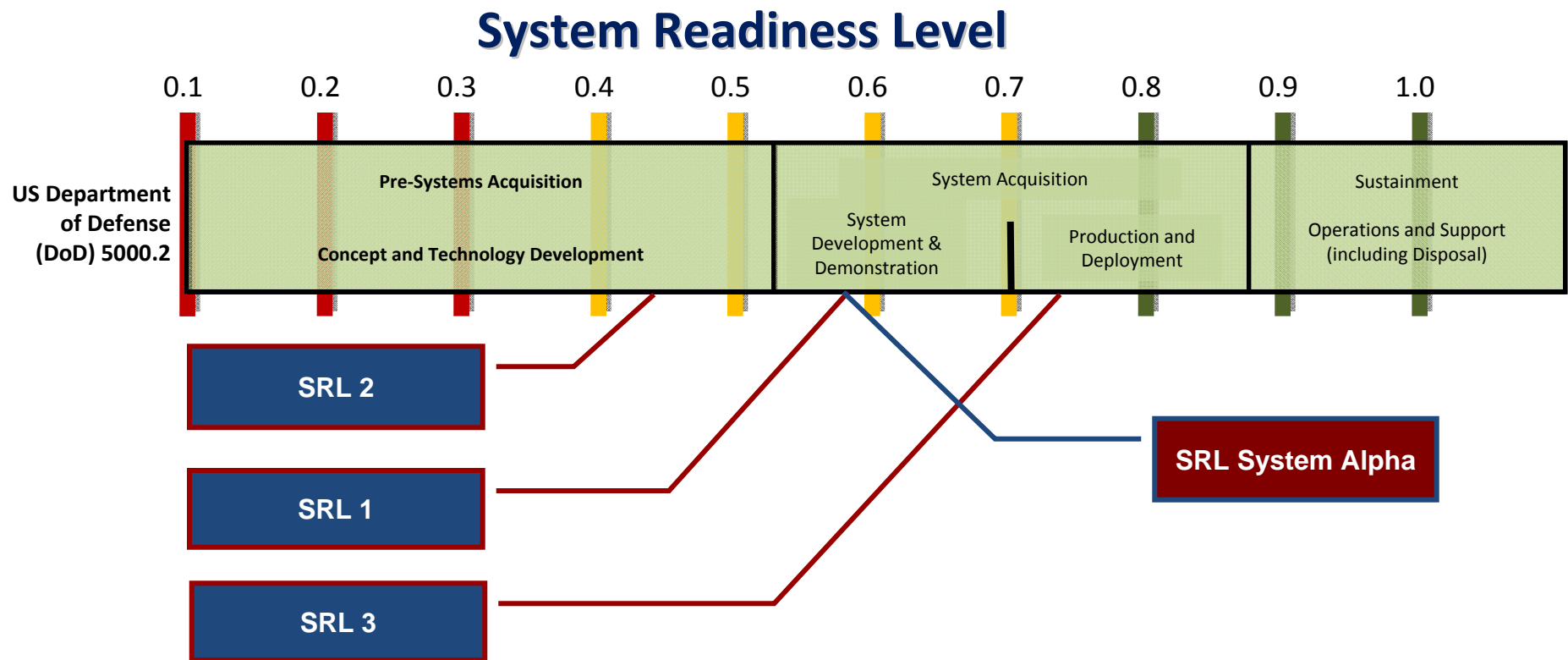

Spiral Development of System Alpha

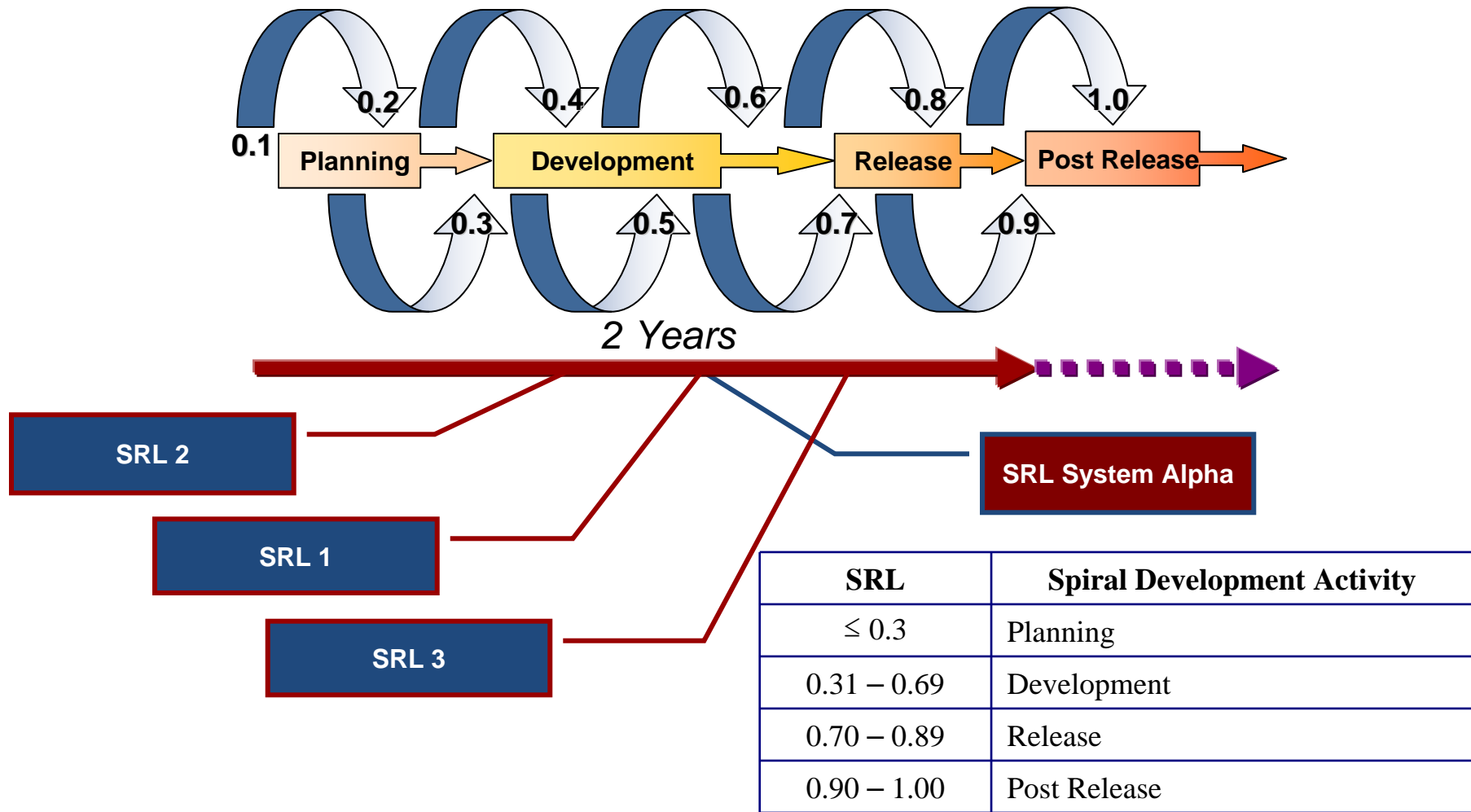

Other Case Examples

Sauser, B., J. Ramirez-Marquez, D. Henry and D. Dimarzio. (2007). "A System Maturity Index for the Systems Engineering Life Cycle." *International Journal of Industrial and Systems Engineering*. 3(6). (forthcoming)

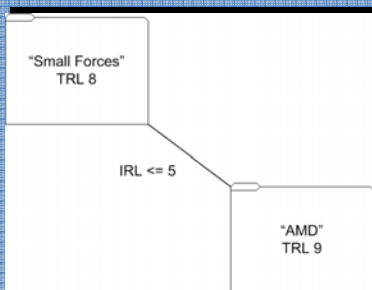

Mars Climate Orbiter (MCO): Robotic spacecraft sent to orbit Mars and collect data on Martian atmospheric conditions, and act as a communications relay for future missions. MCO failed due to impulse-bit data was assumed to be produced by the "Small Forces" files in Newton-Seconds (N-s), whereas "Small Forces" actually output in Pound-Seconds (lbs-s).

SRL = 0.74

Hubble Space Telescope-SM-1: Servicing Mission (SM) to Hubble to correct the spherical aberration present on the primary mirror, and provide necessary support maintenance. SM-1 resulted in successful servicing of Hubble, a return to successful science operations, and a safe return of shuttle crew.

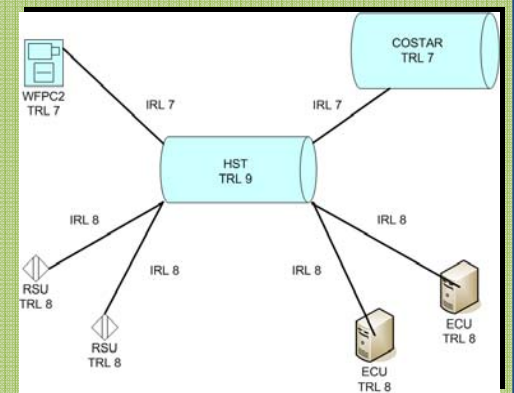

SRL = 0.84

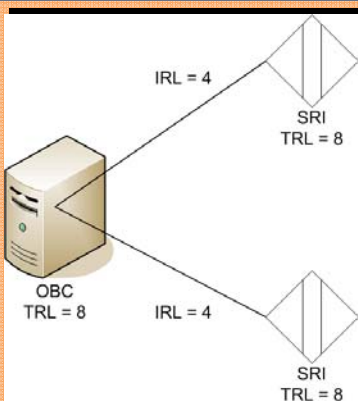

ARIANE 5: Launch platform for delivering payloads into Earth Orbit. ARIANE 5 failed when an inertial Reference System failed 36.7 seconds after launch due to a software exception caused by the rocket's horizontal velocity, which was within thresholds, exceeding the limit of what the onboard-software could handle.

SRL = 0.67

Hubble Space Telescope-RSM: Service Hubble and other spacecraft using a robotic servicing craft thereby reducing cost, and the risk to human life. A problem arose when the technology and concepts for RSM were unproven in space and a RSM seemed not to be feasible in time.

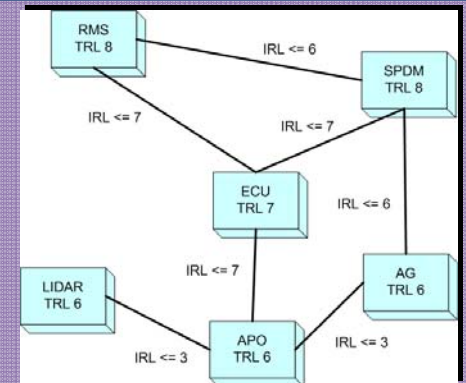

SRL = 0.65

System Readiness Level

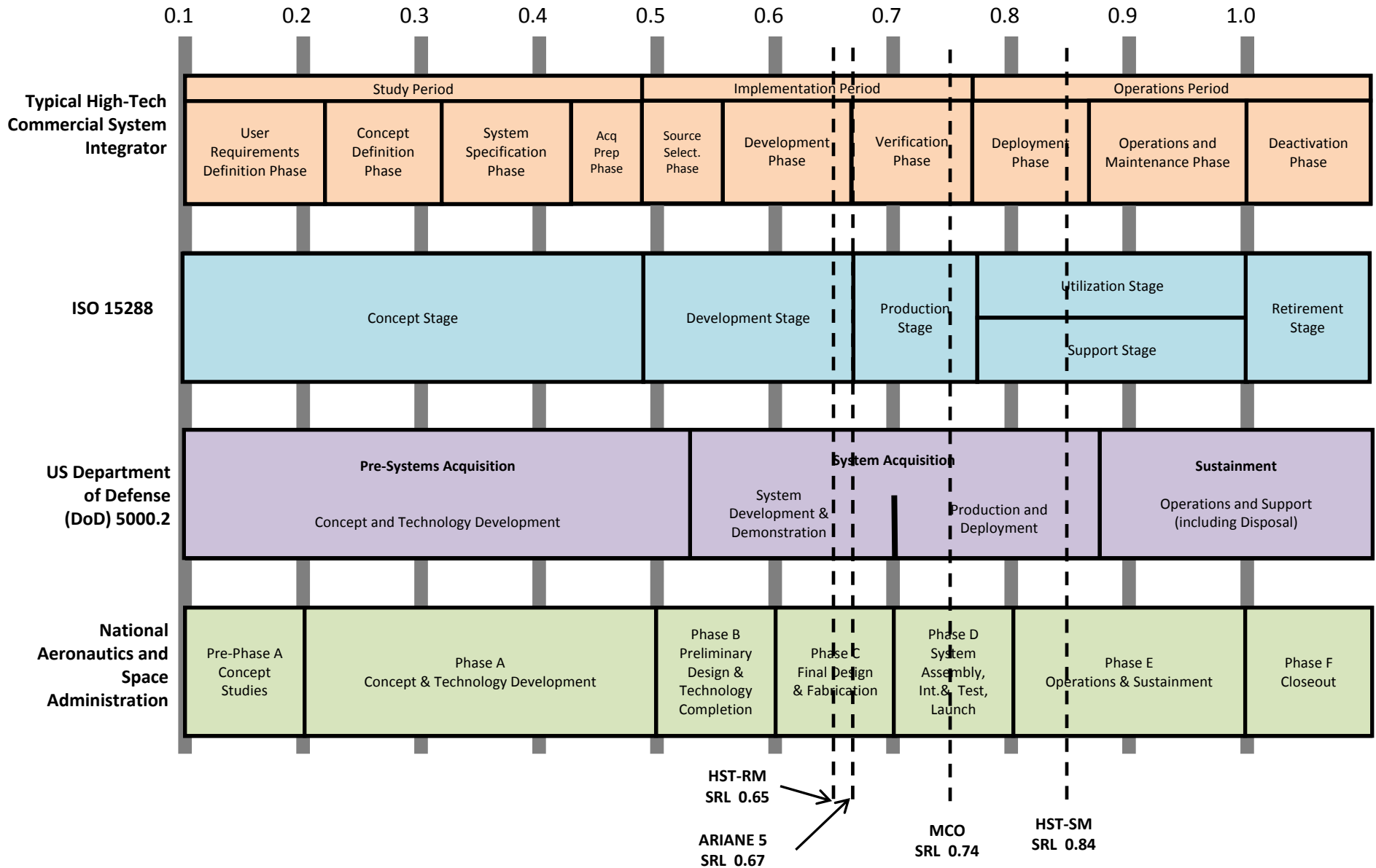

System Readiness Potential (SRP)

Optimization Example of System
Alpha

SRL Optimization of System Alpha*

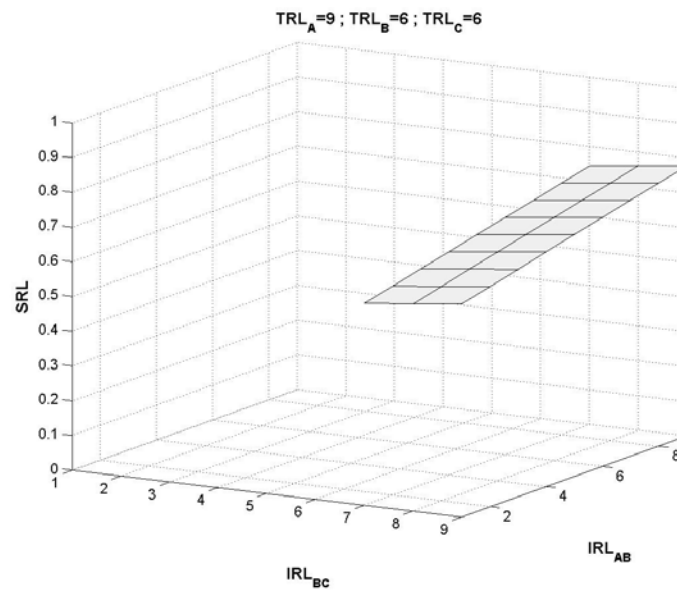
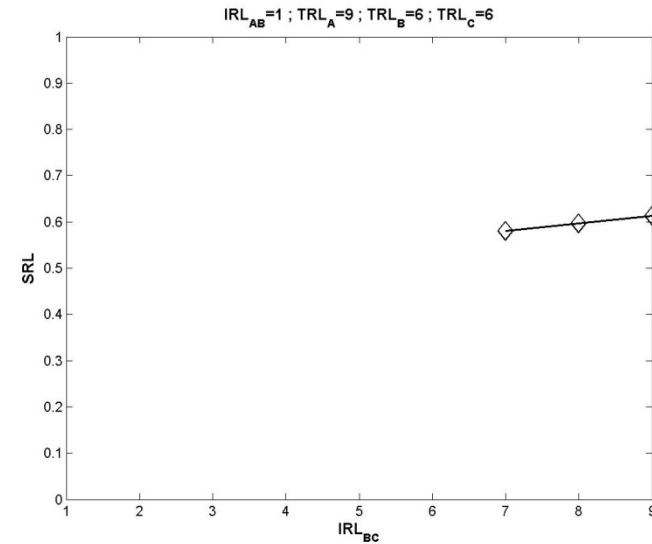
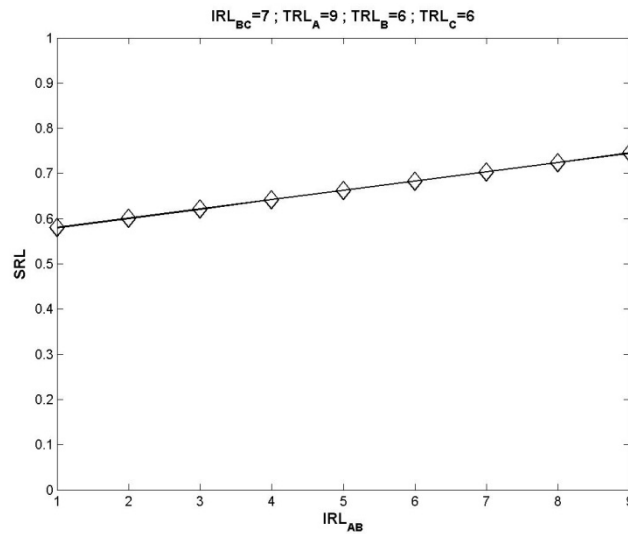

* This example assumes
TRLs are held constant

System Readiness Potential (SRP)

Table 1: Cost and Time Consumption by IRL

Technologies	1,2		2,3	
IRL Level	Cost	Time	Cost	Time
1	\$0	0	\$0	0
2	\$123	80	\$0	0
3	\$219	380	\$0	0
4	\$595	532	\$0	0
5	\$700	621	\$0	0
6	\$808	862	\$0	0
7	\$1,003	997	\$0	0
8	\$1,110	1145	\$400	165
9	\$1,452	1623	\$650	389
Available Resources	Cost	\$1,400	Time	1200

Table 2: Optimization Results

Objective Function (SRL)	0.7243
Cost Constraint	\$1,110
Time constraint	1145
IRL(1,2) Constraint	1
IRL(2,3) Constraint	1

System Readiness Potential (SRP) based on resource allocation

Recommendation:

Increase IRL (1,2) from its current value to 8
Increase IRL (2,3) stays at current value of 7

System Life Cycle of System Alpha

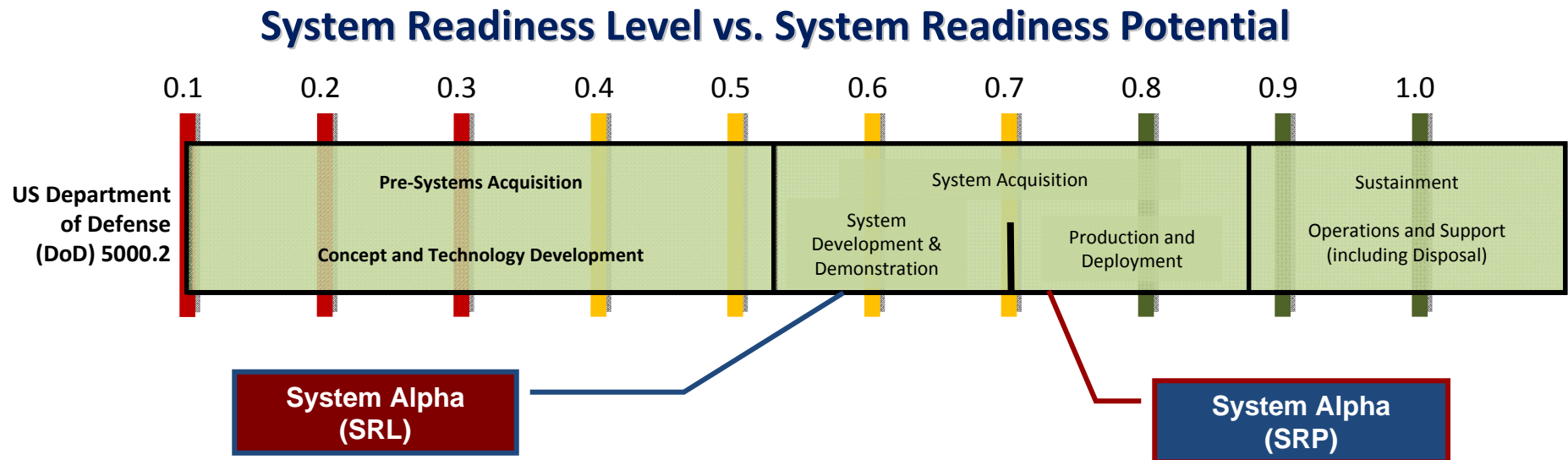

Spiral Development of System Alpha

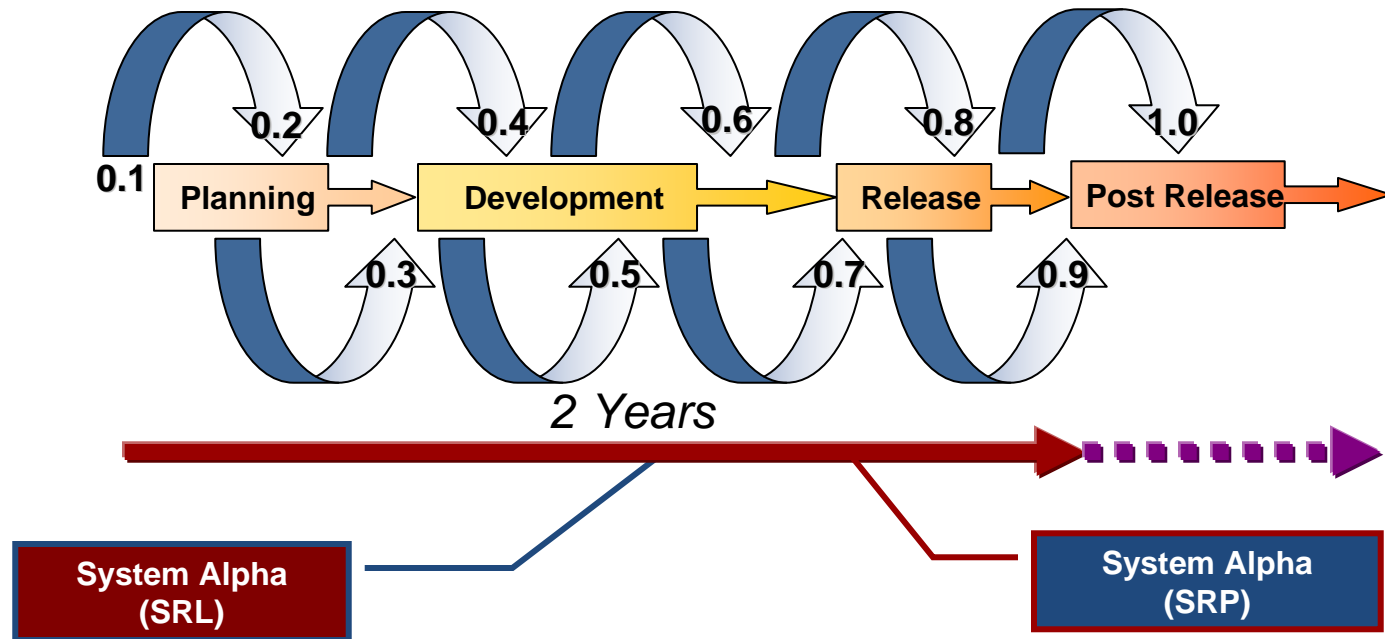

SRL	Spiral Development Activity
≤ 0.3	Planning
0.31 – 0.69	Development
0.70 – 0.89	Release
0.90 – 1.00	Post Release

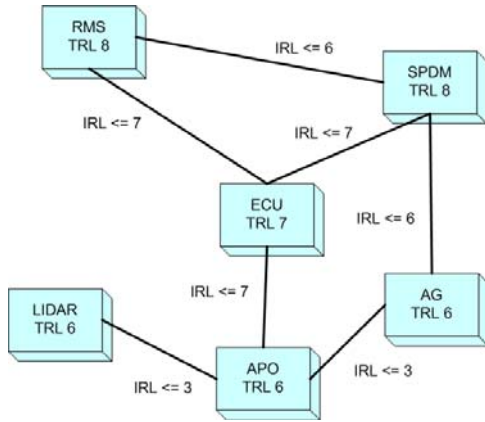

SRL Calculation

$$SRL_i = \frac{1}{n} \sum_{j=1}^n IML_{ij} \times TRL_j$$

System Optimization

SRL Analysis Methods

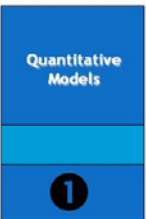

Identify gaps in current approaches

Operations Research Techniques

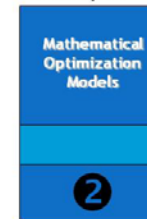

$$\max SRL(IML)$$

s.t.

$$C(IML) \leq C$$

$$T(IML) \leq T$$

Life Cycle Impacts

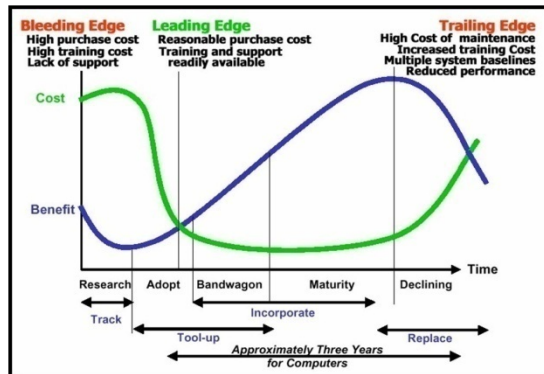

Acquisition Life-cycle Planning

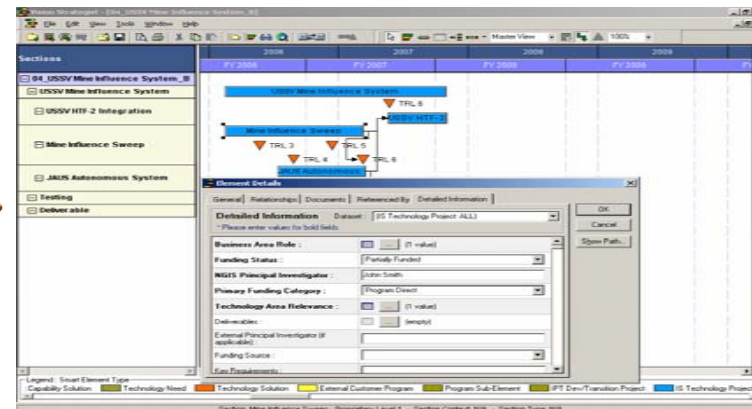

Publications and Acknowledgements

Sauser, B., J. Ramirez-Marquez, D. Henry and D. Dimarzio. (2008). "A System Maturity Index for the Systems Engineering Life Cycle." *International Journal of Industrial and Systems Engineering*. 3(6). (forthcoming)

Gove, R., B. Sauser, J. Ramirez-Marquez. (2007). "Integration Maturity Metrics: Development of an Integration Readiness Level." *Acta Astronautica* (under review)

Ramirez-Marquez, J. and B. Sauser. (2007). "Optimization of a System Maturity Index for the Systems Engineering Life Cycle." Stevens Institute of Technology. (working paper)

Sauser, B.J., D. Verma, J. Ramirez-Marquez, and R. Gove. (2006). "From TRL to SRL: The Concept of Systems Readiness Levels." *Conference on Systems Engineering Research*, April 7-8. Los Angeles, CA

We would like to acknowledge the support of:

- Lockheed Martin
- National Aeronautics and Space Administration
- Naval Postgraduate School
- Northrop Grumman Integrated Systems
- U.S. Army Armament Research Development and Engineering Center

More Case Examples

Dr. Brian Sauser
bsauser@stevens.edu

Dr. Jose Emmanuel Ramirez-Marquez
jmarquez@stevens.edu

Stevens Institute of Technology
School of Systems and Enterprises
Castle Point on Hudson
Hoboken, NJ 07030

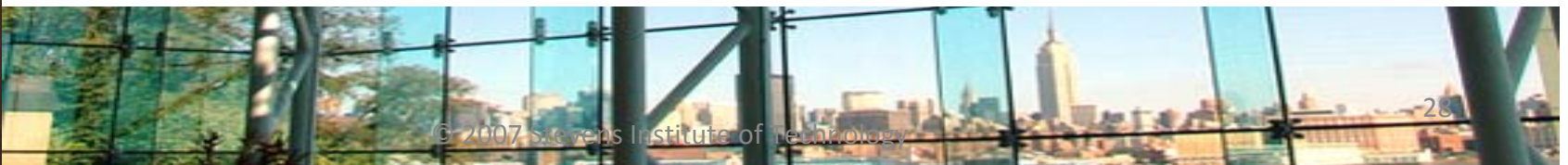
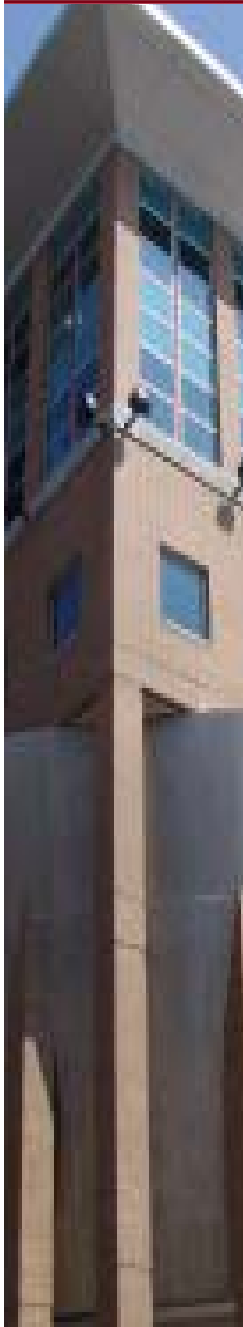

System Readiness Level

- *System Beta** -

* System Beta is based on data collected from a real system.

Evaluating TRL & IRL of System Beta

		IRL				
		Tech 1	Tech 2	Tech 3	Tech 4	Tech 5
TRL						
7	Tech 1		9	7	7	7
5	Tech 2	9		7	7	7
5	Tech 3	7	9		9	7
8	Tech 4	9	9	9		7
4	Tech 5	7	7	7	7	

SRL Calculation of System Beta

	Sub-Sys SRL	Comp SRL
Tech 1	0.67	0.58
Tech 2	0.48	
Tech 3	0.51	
Tech 4	0.85	
Tech 5	0.37	

System Beta should be early to mid-way through a life cycle phase at which it is:

- Developing a system or increment of capability;
- Reducing integration and manufacturing risk;
- Ensuring operational supportability; reducing logistics footprint;
- Implementing any human systems integration;
- Designing for producibility;
- Ensuring affordability and protection of critical program information; and Demonstrating system integration, interoperability, safety, and utility.

System Life Cycle of System Beta

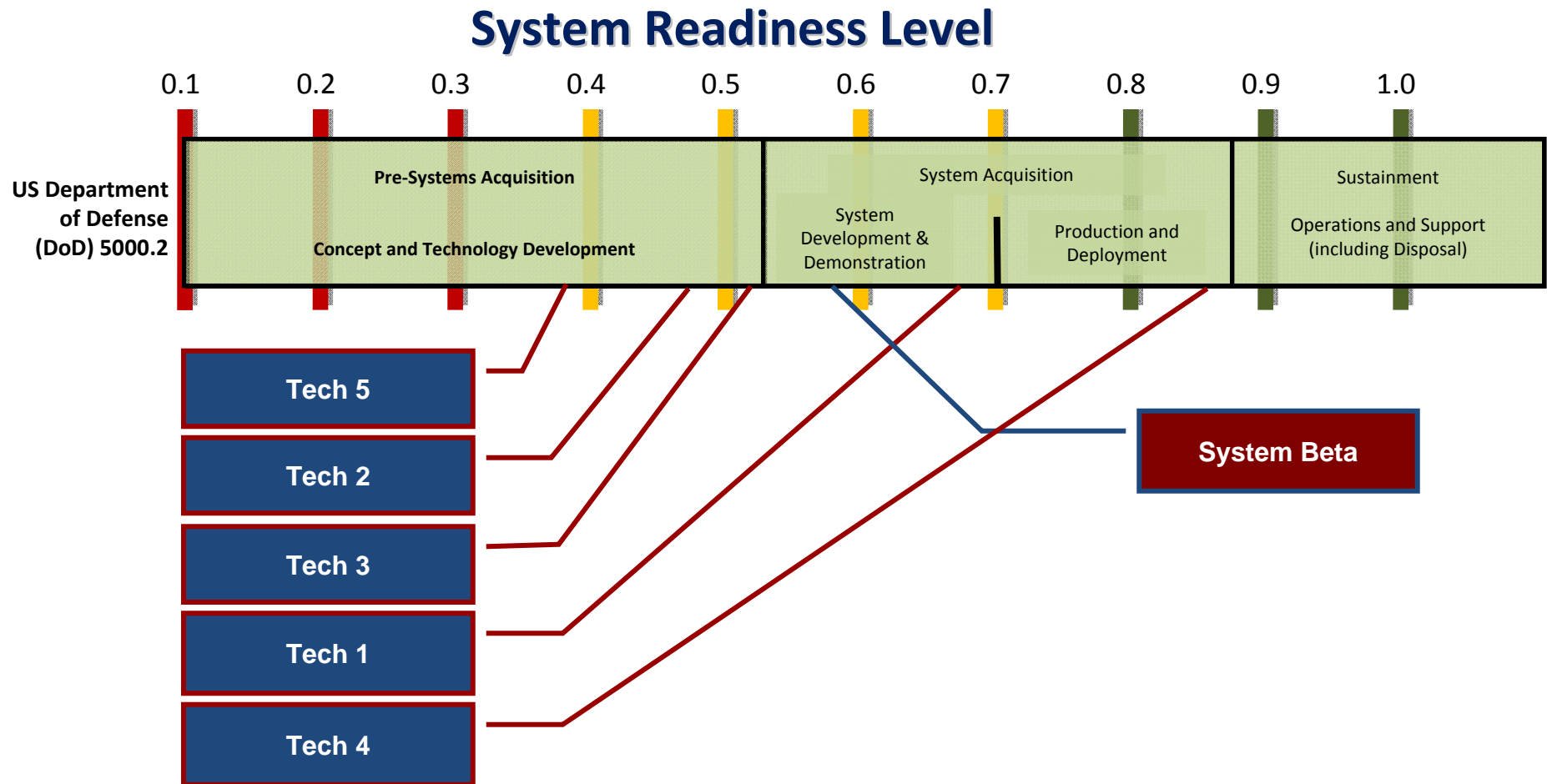

Spiral Development of System Beta

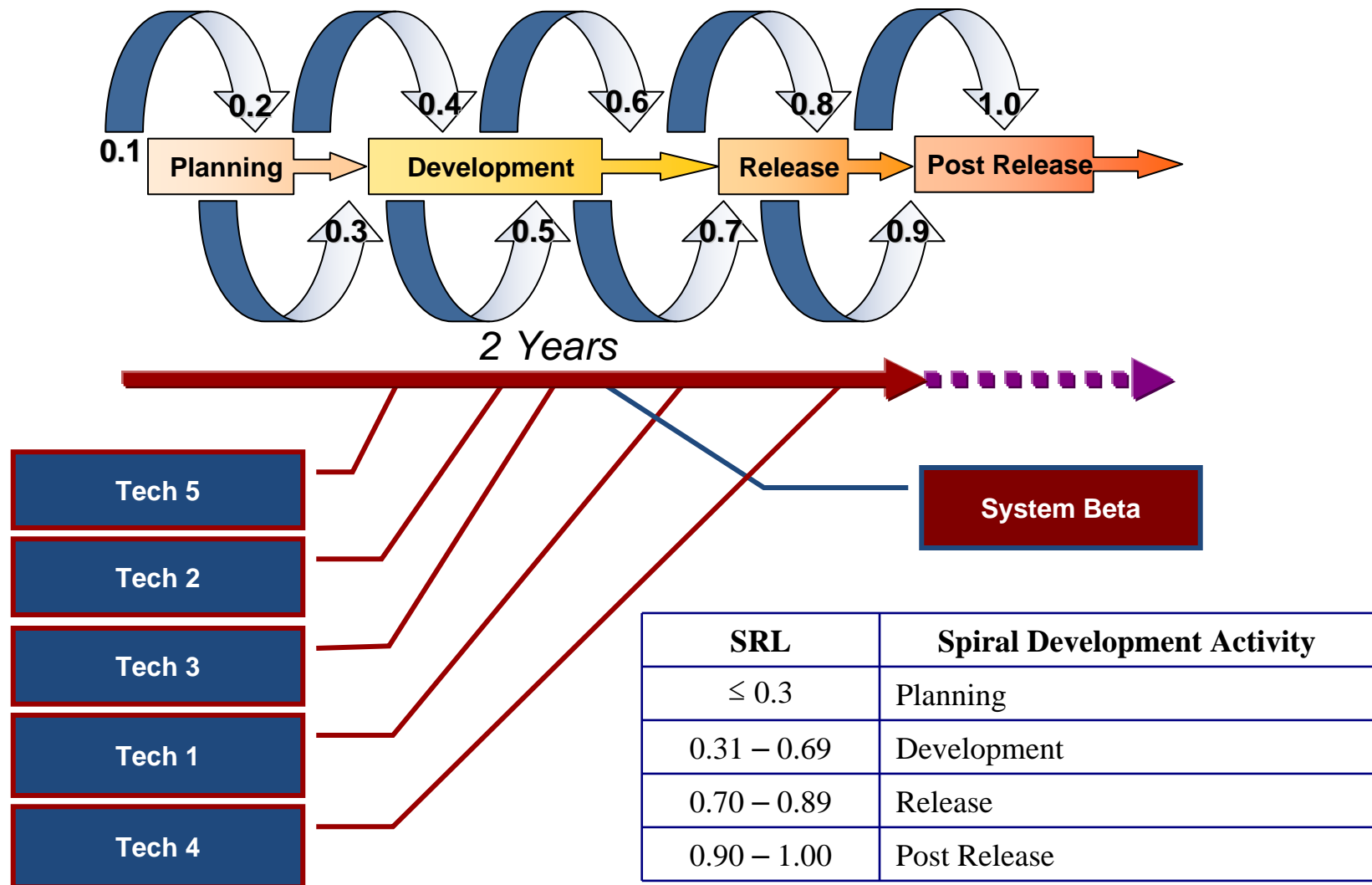

System Readiness Level

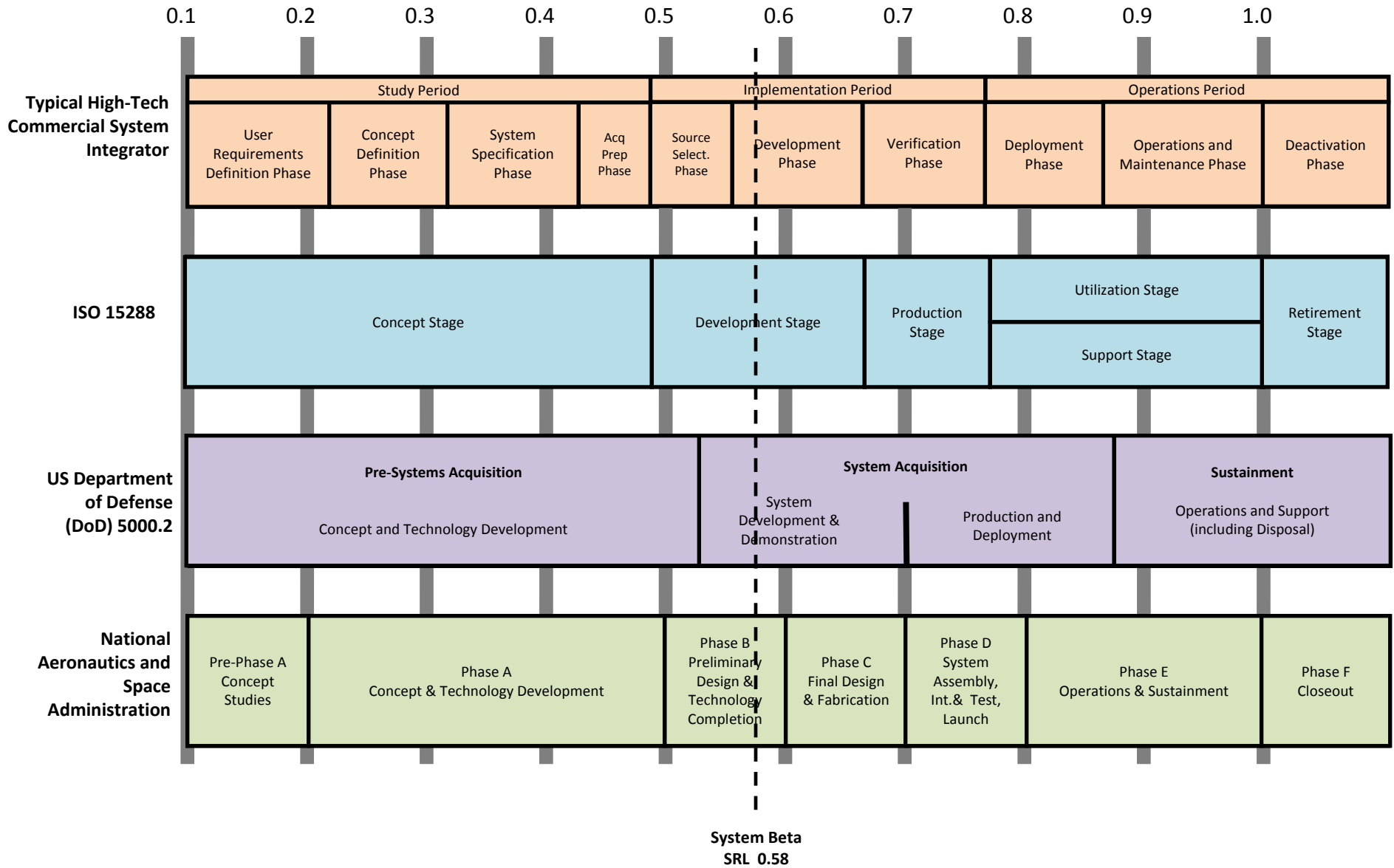

Calculating

System **R**eadiness **L**evel

- *System Delta** -

* System Beta is based on data collected from a real system.

Preliminary Design Review (PDR)

IRL

<i>TRL</i>	Sub-System	Tech 1	Tech 2	Tech 3
2	Tech 1	9	2	3
2	Tech 2	2	9	3
9	Tech 3	3	3	9

System Readiness Level

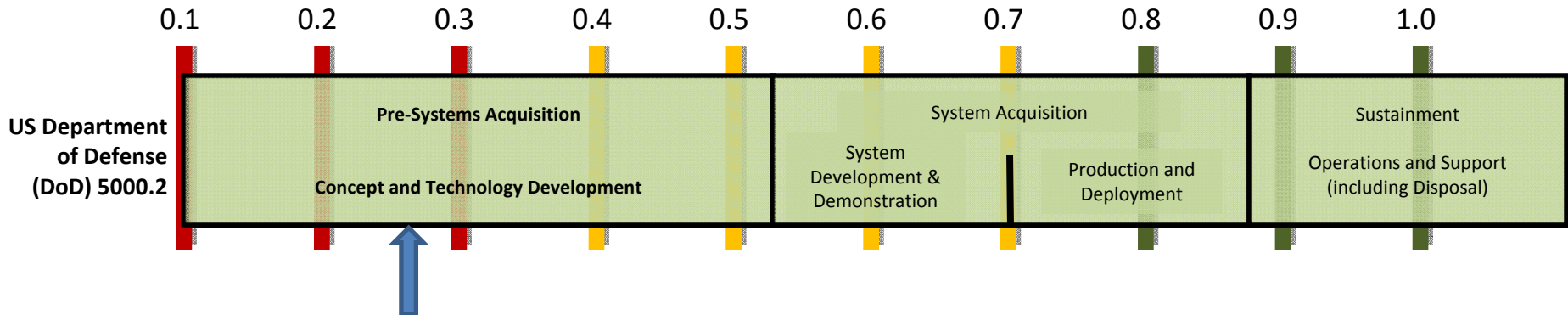

	Sub-Sys SRL	Comp SRL
Tech 1	0.12	0.26
Tech 2	0.12	
Tech 3	0.56	

Critical Design Review (CDR)

TRL	Sub-System	Tech 1	Tech 2	Tech 3
3	Tech 1	9	3	3
3	Tech 2	3	9	3
9	Tech 3	3	3	9

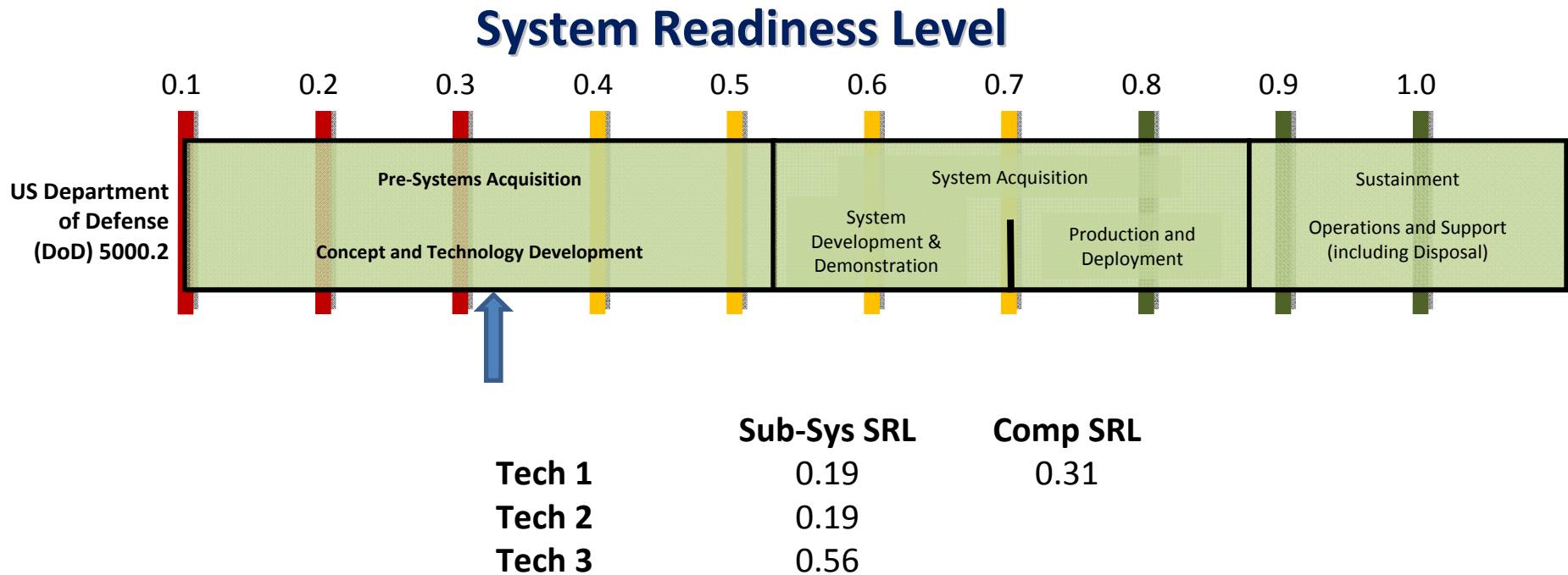

CDR with Modeling & Simulation

TRL	Sub-System	IRL		
		Tech 1	Tech 2	Tech 3
3	Tech 1	9	6	6
3	Tech 2	6	9	6
9	Tech 3	6	6	9

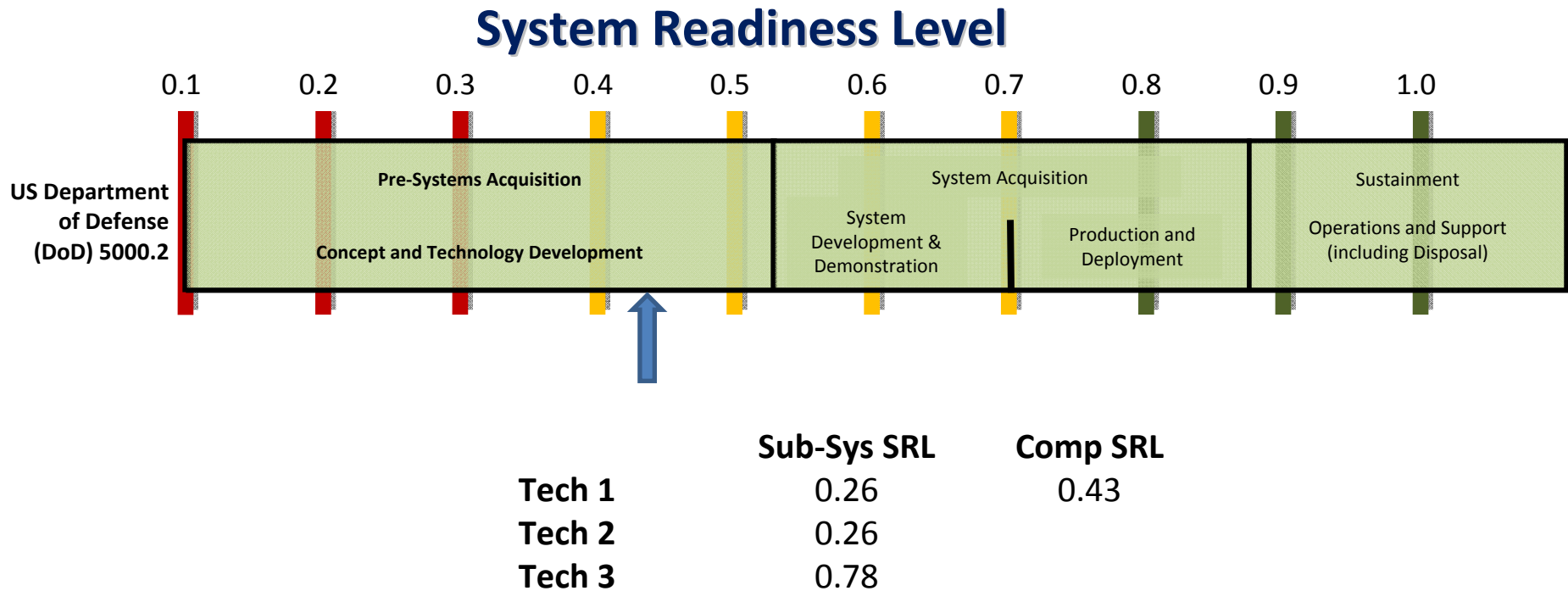

Pre-Integration

TRL	Sub-System	IRL		
		Tech 1	Tech 2	Tech 3
6	Tech 1	9	7	6
6	Tech 2	7	9	4
9	Tech 3	6	4	9

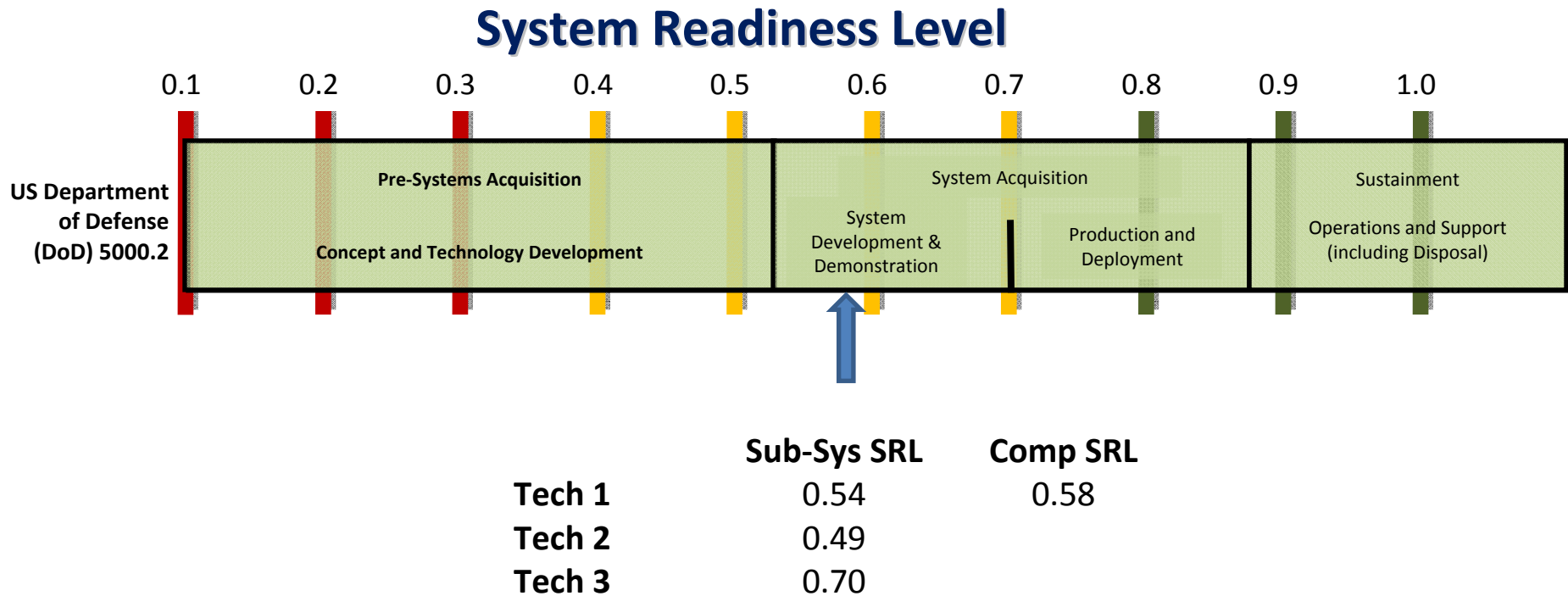

US Department of Defense (DoD) 5000.2

Post-Integration

TRL	Sub-System	IRL		
		Tech 1	Tech 2	Tech 3
6	Tech 1	9	7	6
6	Tech 2	7	9	6
9	Tech 3	6	6	9

System Readiness Level

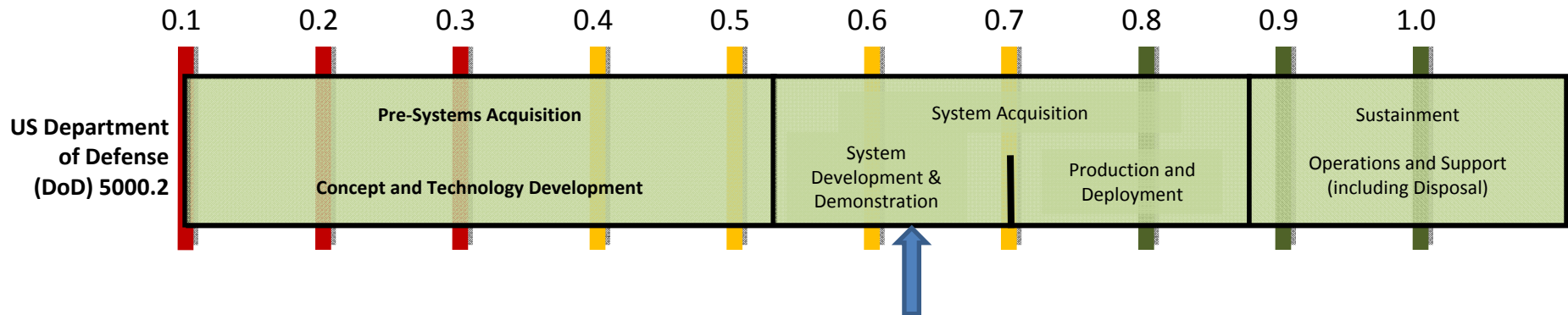

	Sub-Sys SRL	Comp SRL
Tech 1	0.54	0.62
Tech 2	0.54	
Tech 3	0.78	

Pre-Flight Test

TRL	Sub-System	IRL		
		Tech 1	Tech 2	Tech 3
7	Tech 1	9	7	8
7	Tech 2	7	9	7
9	Tech 3	8	7	9

System Readiness Level

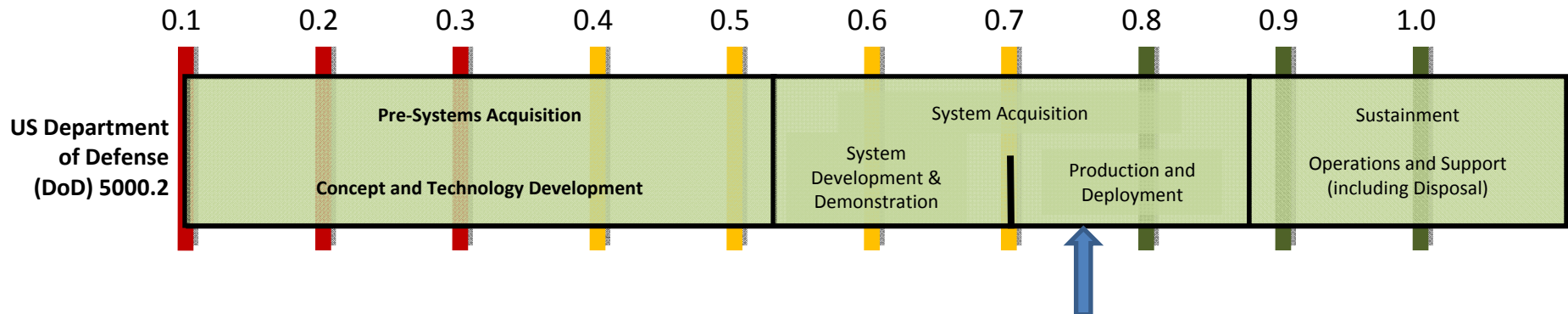

	Sub-Sys SRL	Comp SRL
Tech 1	0.69	0.75
Tech 2	0.66	
Tech 3	0.89	

Post-Flight Test

TRL	Sub-System	IRL		
		Tech 1	Tech 2	Tech 3
8	Tech 1	9	8	8
8	Tech 2	8	9	8
9	Tech 3	8	8	9

System Readiness Level

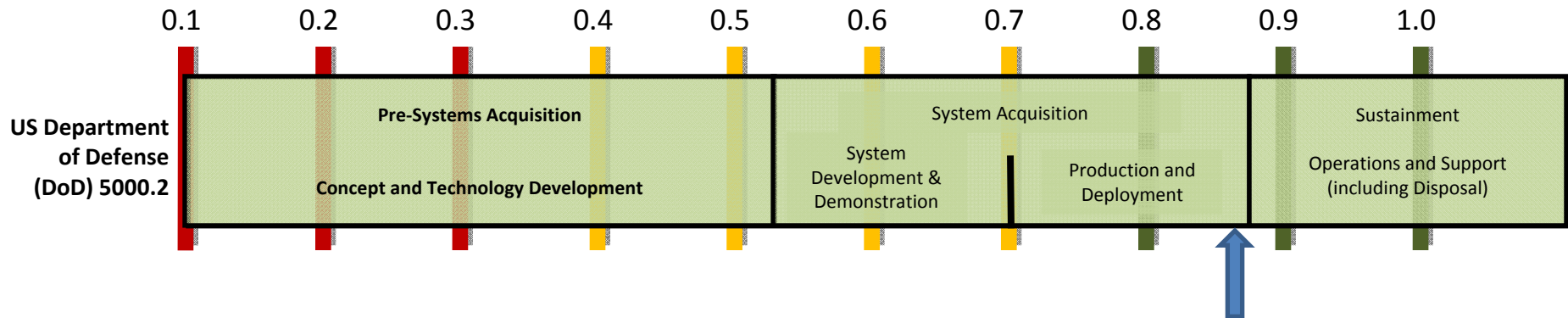

	Sub-Sys SRL	Comp SRL
Tech 1	0.82	0.86
Tech 2	0.82	
Tech 3	0.93	