

## A NOVEL HIGH-THROUGHPUT SCREENING SYSTEM TO EVALUATE THE BEHAVIORAL RESPONSE OF ADULT MOSQUITOES TO CHEMICALS<sup>1</sup>

JOHN P. GRIECO,<sup>2</sup> NICOLE L. ACHEE,<sup>2</sup> MICHAEL R. SARDELIS,<sup>2</sup> KAMLESH R. CHAUHAN<sup>3</sup> AND  
DONALD R. ROBERTS<sup>2</sup>

**ABSTRACT.** A modular and novel assay system for rapid mass screening of chemical compounds for contact irritant and spatial repellent actions against adult mosquitoes is described. The responses of *Aedes aegypti* to various concentrations of 3 topical repellents, deet, Bayrepel®, and SS220, were evaluated. At treatment concentrations  $\geq 25$  nmol/cm<sup>2</sup> of SS220, mosquitoes exhibited significant contact irritant (escape) and spatial repellent (movement away from the chemical source) responses, whereas, a 10-fold increase in the treatment concentration of deet and Bayrepel was required to produce similar responses. The novel bioassay system detected contact irritancy and spatial repellency activity with reproducible results and provided baseline data for determining minimum effective concentrations for other chemicals. The system is compact in size, easy to decontaminate, and requires only a minute quantity of chemical compound.

**KEY WORDS** Assay, screening, behavior, contact irritancy, spatial repellency, mosquitoes

### INTRODUCTION

An important component of programs designed to reduce transmission of some of the world's most important vector-borne diseases, such as malaria and dengue, is the use of chemicals for reducing risk of human-vector contact (WHO 1999, Najera and Zaim 2003). The number of chemicals for such uses is becoming increasingly limited due to an assortment of factors (e.g., bans, environmental concerns, potential adverse effects on human health, resistance, loss of licensure). These issues in conjunction with increased disease problems prompt a need to identify and develop alternative vector control methods as well as new chemicals (Gubler 1998, Zaim and Guillet 2002).

We, along with a major chemical company and a network of investigators, are participants in a multiyear program to identify chemicals that alter arthropod behaviors and to evaluate their efficacy in reducing risks of disease transmission by preventing human-vector contact. One of our primary tasks was to develop a test system that allowed us to screen experimental compounds for behavioral responses due to either direct contact with the compound or detection of a chemical gradient in the air.

Laboratory evaluation of the activity of candidate chemicals for preventing human-vector contact typically involves conducting tests for toxicity and antitibiting response (Anonymous 1983, Shreck and McGovern 1989, Brogdon and McAllister 1998, WHO 1998, Klun and Debboun 2000). Excito-repellency tests are occasionally done with chemicals that are suspected or known to elicit behavioral avoidance responses from contact with chemical residues (irritancy) and from stimulation from a distance without physical contact with the chemical that disrupts normal behavior patterns (e.g., deterrence of entering a treated space or noncontact irritancy or spatial repellency) (Chareonviriyaphap et al. 2004). A number of excito-repellency test systems have been described (WHO 1970, Roberts et al. 1984, Evans 1993, Das 1997, Rutledge et al. 1999, Sungvornyothin et al. 2001). To separate the behavioral responses of contact irritancy from noncontact repellency, Roberts et al. (1997) and Chareonviriyaphap et al. (2002) designed an excito-repellency test system that included a screened inner chamber to prevent test specimens from landing on treated surfaces. Although this assay method identified the irritant action of chemicals applied to the system, there was some doubt in its ability to measure noncontact irritancy due to the enclosed nature of the single-exposure chamber design. In the one chamber system, volatiles could readily saturate the space thus not truly permitting the observance of behavioral response to a gradient of chemical vapor.

Presently, other than for biting response, there is no standard test system for screening new chemicals for effects on adult mosquito behavior. Ideally, such a system would allow high throughput (the ability to quickly do multiple replicates with various treatments), have a small treatment surface area to minimize the amount of chemical required for testing, be readily decontaminated, not require mechanical devices (e.g., wind tunnel), and provide

<sup>1</sup> The work was consistent with National Institutes of Health's fundamental ethical principles of research involving human subjects and the role of participating investigators. The opinions and assertions are the private views of the authors and are not to be construed as official or reflecting the views of the Uniformed Services University of the Health Sciences and U.S. Department of Agriculture. Mention of use of commercial products does not constitute official endorsement or approval of them.

<sup>2</sup> Department of Preventive Medicine and Biometrics, Uniformed Services University of the Health Sciences, 4301 Jones Bridge Road, Bethesda, MD 20814-4799.

<sup>3</sup> Chemicals Affecting Insect Behavior Laboratory, 10300 Baltimore Avenue, Building 007, Room 303, BARC-West, Beltsville, MD 20705-2350.

# Report Documentation Page

Form Approved  
OMB No. 0704-0188

Public reporting burden for the collection of information is estimated to average 1 hour per response, including the time for reviewing instructions, searching existing data sources, gathering and maintaining the data needed, and completing and reviewing the collection of information. Send comments regarding this burden estimate or any other aspect of this collection of information, including suggestions for reducing this burden, to Washington Headquarters Services, Directorate for Information Operations and Reports, 1215 Jefferson Davis Highway, Suite 1204, Arlington VA 22202-4302. Respondents should be aware that notwithstanding any other provision of law, no person shall be subject to a penalty for failing to comply with a collection of information if it does not display a currently valid OMB control number.

1. REPORT DATE <b>2005</b>		2. REPORT TYPE		3. DATES COVERED <b>00-00-2005 to 00-00-2005</b>	
4. TITLE AND SUBTITLE <b>A Novel High-Throughput Screening System to Evaluate the Behavioral Response of Adult Mosquitoes to Chemicals</b>				5a. CONTRACT NUMBER	
				5b. GRANT NUMBER	
				5c. PROGRAM ELEMENT NUMBER	
6. AUTHOR(S)				5d. PROJECT NUMBER	
				5e. TASK NUMBER	
				5f. WORK UNIT NUMBER	
7. PERFORMING ORGANIZATION NAME(S) AND ADDRESS(ES) <b>Uniformed Services University of Health Sciences, Department of Preventive Medicine and Biometrics, Bethesda, MD, 20814</b>				8. PERFORMING ORGANIZATION REPORT NUMBER	
9. SPONSORING/MONITORING AGENCY NAME(S) AND ADDRESS(ES)				10. SPONSOR/MONITOR'S ACRONYM(S)	
				11. SPONSOR/MONITOR'S REPORT NUMBER(S)	
12. DISTRIBUTION/AVAILABILITY STATEMENT <b>Approved for public release; distribution unlimited</b>					
13. SUPPLEMENTARY NOTES					
14. ABSTRACT <b>see report</b>					
15. SUBJECT TERMS					
16. SECURITY CLASSIFICATION OF:			17. LIMITATION OF ABSTRACT	18. NUMBER OF PAGES	19a. NAME OF RESPONSIBLE PERSON
a. REPORT <b>unclassified</b>	b. ABSTRACT <b>unclassified</b>	c. THIS PAGE <b>unclassified</b>			

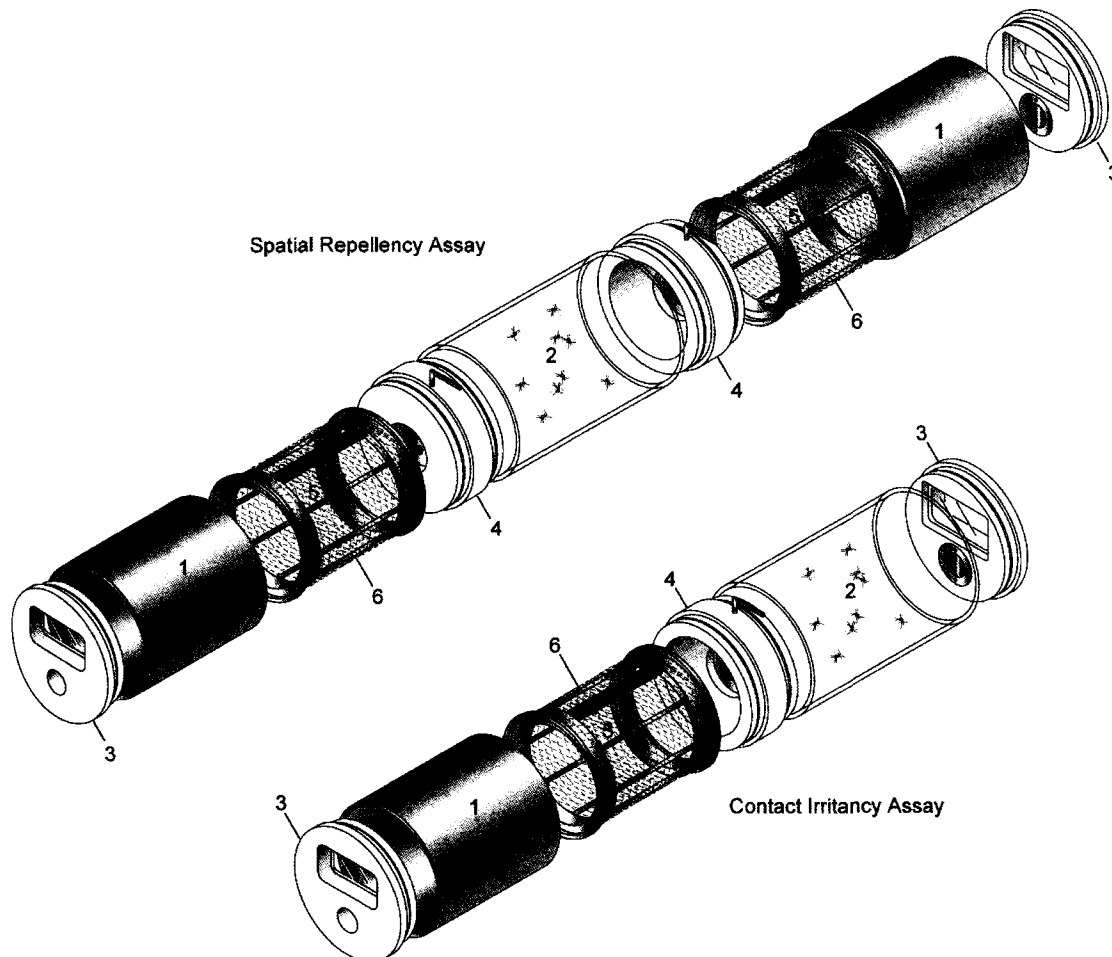

Fig. 1. Schematic drawing of the high-throughput screening system showing the spatial repellency assay (top) and contact irritancy assay (bottom) assemblies. Major components include: 1, treatment (metal) cylinder; 2, clear (Plexiglas) cylinder; 3, end cap; 4, linking section; 5, treatment drum; and 6, treatment net.

consistent results within treatments. Herein, we report on the design and use of a device referred to as the high-throughput screening system (HITSS) and on the responses of adult *Aedes aegypti* (L.) mosquitoes in the HITSS to 3 compounds used in topical repellents.

## MATERIALS AND METHODS

### Assay device

The HITSS has a modular design that allows for examination of 2 behavioral responses (contact irritancy and spatial repellency) as well as toxicity. The major components of the HITSS are illustrated and numbered in Fig. 1. The required number and assembly of the components vary depending on the type of assay to be used. Each treatment cylinder (no. 1) is constructed of aluminum tubing (10.2 cm outside diameter, 0.6 cm thick) that is 14.0 cm long.

Each clear cylinder (no. 2) is constructed of Plexiglas® tubing with the same outside diameter and thickness as the treatment cylinders but with length of 15.9 cm. Midway in the length of the clear cylinders a hole covered with dental dam is provided for transferring mosquitoes. The end caps (no. 3) and linking sections (no. 4) are constructed of Delrin® (Dupont, Wilmington, DE). The end caps (1.9 cm thick × 10.2 cm diameter) have been milled to slide partway inside either the treatment or clear cylinders and modified to provide a circular port for transferring mosquitoes and a rectangular port for viewing. The linking sections (4.4 cm thick × 10.2 cm diameter) have also been milled, similar to the end caps, to slide partway into the treatment of clear cylinders. These sections were modified to form a funnel that leads to a 3.7-cm opening in which an aluminum butterfly valve was installed. The end caps and linking sections are secured to

the treatment and clear cylinder by 3 ball detents that are installed in the ends of the cylinders. The treatment drum (no. 5) is constructed of aluminum, has an outside diameter of 9.5 cm that allows it to just slide inside of the treatment cylinder, and is 11.4 cm long. The treatment net (no. 6) is 100% nylon organdy (No. 4-2, G Street Fabrics, Rockville, MD), sized to cover the outside of the drum insert and held in place by a 1.3 × 11.4-cm flexible magnetic strip (5699K15, McMaster-Carr, Dayton, NJ) (not shown). The cradle (not shown) constructed of 1.3-cm-thick Plexiglas holds the assembled test system steady and parallel to the bench top during assays. Pieces of opaque felt (not shown) are wrapped around the clear cylinder, and depending on the assay to be done, additional felt pieces (not shown) are used to cover the rectangular port in the end caps. Except for the toxicity assay, the various assay configurations are shown in the figure, and the assembly and operation of each assay are described in subsections: Contact irritancy assay, Spatial repellency assay, and Toxicity assay.

### Mosquitoes

*Aedes aegypti* was colonized at Kasetsart University, Bangkok, Thailand, from larvae collected in Patau Village, Kachanaburi Province, Thailand (14°20'11"N, 98°59'45"E), in 2004. Eggs from this colony, F<sub>1</sub> or F<sub>2</sub>, were shipped to the Uniformed Services University of the Health Sciences (USUHS), Bethesda, MD, to establish a colony for mosquito production to be used in our assays. At USUHS, the colony was maintained at ca. 27°C and relative humidity (RH) of ca. 55% under a photoperiod of 12L:12D. Methods for rearing mosquito larvae were similar to those described by Gerberg et al. (1994). Ground fish chow (Cichlid Gold, Kyorin Co., Himeji, Japan) served as the larval diet. Emerged adults in 30.5 cm × 30.5 cm × 30.5 cm stock cages were provided 10% sucrose solution ad libitum and were blood-fed weekly on a volunteer investigator. Females were allowed to oviposit on a paper towel substrate to obtain eggs.

For assays, batches of eggs were flooded, and the resulting larvae were reared to the pupal stage. To handle efficiently the large number of specimens needed for testing, female and male pupae were sorted by size, and 250, determined to be future females, were placed into individual 3.8-liter cartons. To prepare for a day's round of assays, female mosquitoes from the 3.8-liter cartons were transferred in groups of 10 or 20 into 0.5-liter cartons. The 10% sucrose solution was provided to the females up until 24 h before conducting an assay. In our experiment, the females were from the F<sub>3</sub>-F<sub>5</sub> generations and 4-7 days old.

### Test compounds and exposure concentrations

The compounds used in the tests were *N, N*-diethyl-3-methylbenzamide (deet), 1-piperidinecarboxylic

acid, 2-(2-hydroxyethyl)-1-methylpropylester (Bayrepel®), and (1*S*,2'*S*)-2-methylpiperidinyl-3-cyclohexen-1-carboxamide (SS220). The chemical purity of each compound was determined by capillary gas-liquid chromatography (deet and Bayrepel, 98% chemical purity; SS220, 98% chemical purity and 94% stereochemical purity), and ethanol solutions of 27.5, 2.75, 0.275, and 0.0275 nmol/μl were tested for each compound. The compound deet was obtained from Morflex (Greensboro, NC), and Bayrepel from Bayer Corporation (Morristown, NJ). The SS220 was synthesized by Saidru International (Hydrabad, India) and provided by Chemicals Affecting Insect Behavior Laboratory, U.S. Department of Agriculture, Beltsville, MD. Deet is a compound widely used in commercial repellent formulations. Bayrepel, also known as KBR 3023, is a repellent compound developed and registered by Bayer AG (Leverkusen, Germany). Its efficacy has been evaluated in laboratory and field studies (Yap et al. 1998, Yap et al. 2000, Badolo et al. 2004). The SS220 has been shown to be the most active stereoisomer of racemic AI3-37220, 2-methylpiperidinyl-3-cyclohexene-1-carboxamide (McGovern et al. 1978, Klun et al. 2001) and exhibits a level of repellent efficacy comparable with deet and Bayrepel (Klun et al. 2003).

The treatment solutions (3.0 ml) were applied evenly to the treatment nets (330 cm<sup>2</sup>) using a micropipette, resulting in treatment concentrations of 250, 25, 2.5, and 0.25 nmol/cm<sup>2</sup>. We selected them based on published studies on antibiting response with the test compounds (Klun et al. 2000, 2003; Badalo et al. 2004). Additional nets were treated with ethanol (3.0 ml) to serve as untreated controls. All nets were allowed to air-dry for 15 min before use in an assay. Once a net was installed in a treatment cylinder, it remained there during the entire test day. New treatment nets, including control nets, were prepared at the beginning of each test day.

### Assay times, sequence, conditions, and system cleaning

The assays were done within 1-7 h of treating the nettings, mainly between 8:00 a.m. and 4:00 p.m. In general, rounds of contact irritancy assays were done in the morning and rounds of spatial repellency assays were done in the afternoon. Toxicity assays were done at various times during a testing day. For each compound tested, the response to the lowest treatment concentration was evaluated first and then followed by the higher-treatment concentrations. For all test days, the laboratory temperature averaged 24°C (range 23°-26°C) and the RH averaged 47% (range 25-60%). All assays were done in a fume hood. System cleaning was done when changing between chemicals occurred and at the end of a day's round of testing. Cleaning involved washing with acetone all parts of the system that contacted the treatment nets and washing in a detergent solution (Liqui-Nox, Aloconox, Inc.,

New York) all other parts of the system. Before reuse, both acetone- and detergent-washed parts were allowed to air-dry overnight or for at least 1 h.

#### Contact irritancy assay

A clear cylinder and the treatment cylinder were connected with a linking section so that the narrow end of the funnel pointed toward the clear cylinder. The linking section's butterfly valve was turned to the closed position. An end cap was then placed on the open end of the clear cylinder, and opaque felt cloth pieces were wrapped around the clear cylinder and placed over the viewing port of the cylinder's end cap to prevent light from eliciting any type of phototactic pressure on the mosquitoes in the chamber. A treatment drum, with treatment net affixed to it, was inserted into the treatment cylinder and an end cap installed. The viewing port of this end cap was also covered with opaque felt cloth. The entire assembly was then put into the cradle. Ten mosquitoes were transferred into the treatment end of the assembly and, after 30 sec, the butterfly valve was placed in the open position. After 10 min, the valve was again closed, and counts were immediately made of the number of mosquitoes in the clear end (number escaping), in the treatment end, and in the clear and treated ends that appear to be knocked down (i.e., lying on its side and not able to right itself after gentle tapping of the chamber). For all trials, a second assay was simultaneously run to serve as a control in which the treatment was an ethanol-treated net. The ratio of treatment to control assays was either 1:1 or 1:2. To prepare for the next replicate, the mosquitoes were transferred from the assay system using mechanical aspiration. Six replicates were done at each treatment concentration.

#### Spatial repellency assay

An end cap was emplaced on a treatment cylinder and then a treatment drum affixed with test-compound-treated netting was slid inside the cylinder. A linking section was attached to the cylinder with the narrow end of the section oriented toward the inside of the newly formed chamber (treated chamber). The same steps were repeated to form a second chamber (control chamber) identical to the first except that a diluent-treated netting was used. The treated and control chambers were connected to each other by a clear cylinder to form the complete spatial repellency assay assembly. The butterfly valves in the linking sections were set to the closed position. Twenty mosquitoes were transferred into the clear (central) chamber, and an opaque cloth was wrapped around it. The viewing ports in the end caps were not covered with the opaque cloth to allow the light at the ends of the chamber system to serve as an attractant for *Ae. aegypti*. The assembly was placed in the cradle,

and, after a 30-sec "settling down," or "acclimation," period, the butterfly valves were simultaneously opened. After 10 min, the valves were simultaneously closed and the number of mosquitoes in each chamber was counted. We also recorded the number of mosquitoes that were knocked down. The mosquitoes were transferred from assembly using mechanical aspiration to prepare for the next replicate. Between replicates, the assembly was partially disassembled (the clear cylinder detached from the treated and control chambers, and the linking section removed from the control chamber) to allow for any volatilized chemical to clear from the assembly. For each compound tested in the spatial repellency assay, 8–12 replicates were done at each treatment concentration.

A spatial activity index (SAI) based on the oviposition activity index of Kramer and Mulla (1979) was used to evaluate the responses of female mosquitoes in the spatial repellency assay. We calculated the SAI for each experimental replication as  $SAI = (N_c - N_t)/(N_c + N_t)$  in which  $N_c$  is the number of females in the control chamber of the spatial repellency assay device and  $N_t$  is the number of females in the treated chamber of the spatial repellency assay device. The SAI is a measure of the proportion of females in the control chamber over the treated chamber after correcting for the proportion of females in the control chamber. The SAI varies from -1 to 1, with zero indicating no response.

#### Toxicity assay

The assembly configuration for this assay was similar to the contact irritancy assay, except without the clear cylinder and its end cap. The opaque cloth-viewing port covers were not used in this assay. After preparing a chamber to include the appropriate treatment netting and assembling the test unit, 20 mosquitoes were transferred into the chamber, and the test unit was set in the cradle. After 1 h, the number of knocked-down mosquitoes was recorded and all (knocked down and those still mobile) were transferred to holding cartons. These mosquitoes were provided a 10% sucrose-soaked cotton ball and returned to the insectary. Their mortality was recorded after 24 h. As with the contact irritancy assay and for all trials, an accompanying assay in which the treatment was an ethanol-treated netting served as a control. The ratio of treatment to control assays was either 1:1 or 1:2. Six replicates were done at each treatment concentration.

#### Data analysis

Contact irritancy assay data were analyzed using the Wilcoxon 2-sample test (PROC NPAR1WAY, SAS Institute 1999a) (SAS Institute, Cary, NC) to examine the difference between the number escaping from treated and control chambers. Spatial re-

Table 1. Responses of female *Aedes aegypti*<sup>1</sup> in the contact irritancy assay to 4 different concentrations of deet, Bayrepel, and SS220.

Repellent	Concentration (nmol/cm <sup>2</sup> )	Number of trials (no. mosq.)	Number escaping (mean ± SE)		Corrected percent escaping <sup>2</sup> (mean ± SE)	P <sup>3</sup>
			Treated	Control		
deet	0.25	6 (60)	2.3 ± 0.4	1.5 ± 0.3	11 ± 8	0.2727
	2.5	6 (60)	2.2 ± 1.1	1.2 ± 0.5	6 ± 8	0.6537
	25	6 (60)	6.3 ± 1.7	1.8 ± 0.8	33 ± 4	0.0758
	250	6 (60)	3.5 ± 0.9	0.7 ± 0.4	26 ± 9	0.0455
Bayrepel	0.25	6 (60)	0.2 ± 0.2	1.7 ± 0.6	-24 ± 4	0.0606
	2.5	6 (60)	0.5 ± 0.3	1.0 ± 0.6	-15 ± 5	0.6970
	25	6 (60)	2.8 ± 0.8	1.7 ± 0.6	18 ± 13	0.3723
SS220	250	6 (60)	3.8 ± 1.0	0.7 ± 0.4	26 ± 14	0.0216
	0.25	6 (60)	1.2 ± 0.5	1.2 ± 0.4	-1 ± 5	0.9978
	2.5	6 (60)	3.7 ± 0.5	1.2 ± 0.4	31 ± 9	0.0087
	25	6 (60)	5.2 ± 0.6	1.5 ± 0.7	45 ± 13	0.0065
	250	6 (60)	3.2 ± 0.8	0.2 ± 0.2	39 ± 13	0.0065

<sup>1</sup> Four 7-day-old, non-blood-fed, 24-h sugar-starved Thai strain.

<sup>2</sup> For each trial, percent escaping after correction using Abbott's formula.

<sup>3</sup> P-values are from Wilcoxon 2-sample test for difference between the number escaping in a chemical treated assembly and in an ethanol-treated (control) assembly.

pellency assay data were analyzed by a nonparametric signed-rank test (PROC UNIVARIATE, SAS Institute 1999a) to determine whether the mean SAI for each treatment was significantly different from zero. For the toxicity data, percent knockdown and mortality values were corrected using Abbott's formula (Abbott 1925) and transformed to arcsine square root values for analysis of variance. For each chemical, knockdown and mortality at each treatment concentration were compared and separated using Tukey's honestly significant difference test at  $P = 0.05$  (SAS Institute 1999b). Means ± SE of untransformed data are reported.

## RESULTS

### Contact irritancy

In general, mean number escaping from treated chambers and corrected percent escaping increased

with treatment concentration (Table 1). A significant ( $P < 0.05$ ) contact irritancy response to SS220 was observed at treatment concentrations  $\geq 2.5$  nmol/cm<sup>2</sup>, while deet and Bayrepel did not result in a significant contact irritancy response except at the highest treatment concentration tested, 250 nmol/cm<sup>2</sup> (Table 1).

### Spatial repellency

Mean percent responding was nearly uniform among the repellent compounds and treatment concentrations, with ranges of 11–16%, 8–14%, and 12–18%, for deet, Bayrepel, and SS220, respectively (Table 2). A significant spatial repellency response (Table 2) was documented for treatment concentrations  $\geq 25$  nmol/cm<sup>2</sup> of SS220. In contrast, the effect of the 250 nmol/cm<sup>2</sup> of deet treatment was very nearly significant at the 5% level ( $P$

Table 2. Responses of female *Aedes aegypti*<sup>1</sup> in the spatial repellency assay to 4 different concentrations of deet, Bayrepel, and SS220.

Repellent	Concentration (nmol/cm <sup>2</sup> )	Number of trials (no. mosq.)	Mean percent responding (SE)	Mean SAI <sup>2</sup> (SE)	SR <sup>3</sup>	P > S
deet	0.25	9 (180)	16 (4)	-0.07 (0.20)	-2.0	0.6875
	2.5	9 (180)	13 (4)	0.03 (0.24)	0.5	1.0000
	25	8 (160)	11 (3)	0.31 (0.17)	6.0	0.1875
	250	12 (240)	12 (3)	0.47 (0.19)	19.0	0.0566
Bayrepel	0.25	9 (180)	10 (2)	0.33 (0.22)	8.5	0.1719
	2.5	9 (180)	8 (3)	0.00 (0.24)	0.0	1.0000
	25	9 (180)	13 (5)	0.22 (0.20)	5.5	0.3125
SS220	250	9 (180)	14 (6)	0.78 (0.15)	14.0	0.0156
	0.25	9 (180)	12 (3)	0.15 (0.24)	3.5	0.5625
	2.5	9 (180)	16 (3)	0.27 (0.23)	5.0	0.3750
	25	9 (180)	12 (3)	1.00 (0.00)	22.5	0.0039
	250	9 (180)	18 (4)	0.97 (0.02)	22.5	0.0039

<sup>1</sup> Four 7-day-old, non-blood-fed, 24-h sugar-starved Thai strain.

<sup>2</sup> SAI, spatial activity index. See text for details.

<sup>3</sup> SR, signed-rank statistic derived through PROC UNIVARIATE (SAS Institute 1999a).

Table 3. Knockdown (KD) and mortality (MORT) of female *Aedes aegypti*<sup>1</sup> in the toxicity assay to 4 different concentrations of deet, Bayrepel, and SS220.

Repellent	Concentration (nmol/cm <sup>2</sup> )	Number of trials (no. mosq.)	1 h KD <sup>2</sup> (mean % ± SE)	24 h MORT mean % ± SE)
deet	0.25	6 (120)	30 ± 19a	12 ± 6a
	2.5	6 (120)	41 ± 16a	27 ± 4ab
	25	6 (120)	52 ± 17a	48 ± 13b
	250	6 (120)	99 ± 2b	99 ± 1c
Bayrepel	0.25	6 (120)	0 ± 0a	3 ± 1a
	2.5	6 (120)	0 ± 0a	5 ± 2a
	25	6 (120)	41 ± 6b	11 ± 3a
	250	6 (120)	97 ± 1c	42 ± 6b
SS220	0.25	6 (120)	1 ± 1a	3 ± 2a
	2.5	6 (120)	0 ± 0a	4 ± 3a
	25	6 (120)	100 ± 0b	99 ± 1b
	250	6 (120)	100 ± 0b	100 ± 0b

<sup>1</sup> Four 7-day-old, non-blood-fed, 24-h sugar-starved Thai strain.

<sup>2</sup> Knockdown and mortality of controls were <1% overall. Values within each column (by repellent) followed by the same letter did not differ significantly ( $P \leq 0.05$ ) among the treatment concentrations.

= 0.0566), and the effect of the 250 nmol/cm<sup>2</sup> of Bayrepel was very nearly significant at the 1% level ( $P = 0.0156$ ).

### Toxicity

Of the 3 repellent compounds, only deet gave consistent modest levels (30–40% range) of knockdown at treatment concentrations of 0.25 and 2.5 nmol/cm<sup>2</sup>. Regardless of the test repellent compound, a treatment concentration of 250 nmol/cm<sup>2</sup> resulted in knockdown of nearly all mosquitoes. Additionally, SS220 at a treatment concentration of 25 nmol/cm<sup>2</sup> gave 100% knockdown. A treatment concentration of 25 nmol/cm<sup>2</sup> of SS220 resulted in nearly 100% mortality, while a treatment concentration of 250 nmol/cm<sup>2</sup> of deet was needed to produce similar mortality. Even at the highest treatment concentration tested (250 nmol/cm<sup>2</sup>), Bayrepel only resulted in about 42% mortality (Table 3).

### DISCUSSION

*Aedes aegypti* exposed to deet, Bayrepel, and SS220 in the HITSS showed varying behavioral responses, depending on type of exposure, chemical, and treatment concentration. Exposure to deet at the 4 tested concentrations resulted in low levels of contact irritancy response (escaping) and no detectable spatial repellent activity. These findings are in agreement with a study done by Kline et al. (2003) in which a dual port olfactometer was used. Contact irritancy and spatial repellency responses of mosquitoes to Bayrepel and SS220 have not been previously reported. In addition, the adulticidal activity of topical repellent compounds is not widely reported (Sarkaria and Brown 1951, Elliott 1964). Recently, Xue et al. (2003) reported on the toxicity of a number of commercial topical repellent formulations that have synthetic organic and

botanical active ingredients. This report found that a number of deet-containing products caused knockdown and were toxic to *Ae. aegypti* (L.), *Aedes albopictus* Skuse, and *Anopheles quadrimaculatus* Say. Because the study conducted by Xu et al. did not quantify the exposure concentration, it was not possible to compare their results with ours. Despite not running tests with additional concentrations of SS220 that would have allowed us to calculate lethal concentration 50 and 90 values, it appeared that SS220 was more toxic than deet. At a test concentration of 25 nmol/cm<sup>2</sup>, SS220 gave nearly 100% knockdown and mortality, while deet gave only around 50% knockdown and mortality. This highlights that the toxic effects of test compounds, to include knockdown and mortality, should be considered when assessing results from behavioral assays because intense toxic action could quickly overwhelm a mosquito's ability to move (Haynes 1988).

The HITSS's design has a number of features that make it desirable for use in the discovery phase of the development of novel compounds that modify vector behavior. It is compact in size and allows testing to be done within a chemical fume hood. Thus, we were able to work safely with compounds that had unknown toxicological properties. The quantity of chemical needed for testing is minute due to the size of the treatment surface (netting), and the ability to reuse the netting in test replicates or other test types depending on the volatility of the compound. This aspect of the system's design permits testing of compounds that are only available in milligram quantities. The modular design of the system allows for quick transitions between replicates and test type, thus making it possible to do many assays in 1 day. For example, on a typical day in our laboratory, we did 21 assays with a single HITSS (6 contact irritancy, 9 spatial repellency, and 6 toxicity assays). Because the parts of the sys-

tem that come in contact with test compounds are made of metal, they can be chemically cleaned for use with different types of compounds.

The results from this study showed that the HITSS provides consistent, quantifiable measures of behavioral responses with a relatively low number of replicates. Further studies are being conducted with other chemicals (e.g., selected pyrethroid, organophosphates, carbamates, and chlorinated hydrocarbons) to develop a more comprehensive understanding of the range of behavioral response levels in the system's assay types. The tests with repellent compounds enabled us to establish a baseline measure of responses and select the range of treatment concentrations that allowed for efficacious collection of meaningful data when screening a high number of compounds. It is important to note that, because it has been established that interspecific and intraspecific variation in antitesting response to deet (Rutledge et al. 1983, Curtis et al. 1987) exist, selection of a laboratory test mosquito population for behavioral assays, such as ones using the HITSS, should be based on where field studies with a candidate product will be done. We selected a Thailand strain population of *Ae. aegypti* to test in the laboratory because we will do field trials with chemical leads in Thailand. Preliminary field studies are planned for Thailand to validate the results from the laboratory studies with the HITSS.

#### ACKNOWLEDGMENTS

We thank Mark Arnold, Mark Brown, and Murray Swanson, U.S. Army Medical Material Development Activity, Fort Detrick, MD, for designing and fabricating the HITSS; Luana Arce, Tara Foggie, and Corinne Klein for running the assays; Theeraphap Chareonviriyaphap, Kasetsart University, Bangkok, Thailand, for providing *Ae. aegypti*; Sofia del Castillo, Audio Visual Center, USUHS, for preparing the figure; and Ranjini Iyenger, Chemicals Affecting Insect Behavior Laboratory, USDA, Beltsville, MD, for preparing standard solutions of test compounds. This work is supported by a grant from the National Institutes of Health (grant no. 5U01AI054777-02).

#### REFERENCES CITED

- Abbott WS. 1925. A method of computing the effectiveness of an insecticide. *J Econ Entomol* 18:265-267.
- Anonymous. 1983. Standard test methods for laboratory testing of non-commercial mosquito repellent formulations on the skin. Standard E951-83. Philadelphia: American Society for Testing and Materials.
- Badolo A, Ilboudo-Sanogo E, Ouedraogo AP, Costantini C. 2004. Evaluation of the sensitivity of *Aedes aegypti* and *Anopheles gambiae* complex mosquitoes to two insect repellents: DEET and KBR 3023. *Trop Med Int Health* 9:330-334.
- Brogdon WG, McAllister JC. 1998. Simplification of adult mosquito bioassays through use of time-mortality determinations in glass bottles. *J Am Mosq Control Assoc* 14:159-164.
- Chareonviriyaphap T, Prabaripai A, Bangs MJ. 2004. Excito-repellency of deltamethrin on the malaria vectors, *Anopheles minimus*, *Anopheles dirus*, *Anopheles swaiwongporni*, and *Anopheles maculatus*, in Thailand. *J Am Mosq Control Assoc* 20:45-54.
- Chareonviriyaphap T, Prabaripai A, Sungvornyoethrin S. 2002. An improved excito-repellency test chamber for mosquito behavioral tests. *J Vector Ecol* 27:250-252.
- Curtis CF, Lines JD, Ijumba J, Callaghan A, Hill N, Karimzad MA. 1987. The relative efficacy of repellents against mosquito vectors of disease. *Med Vet Entomol* 1:109-119.
- Das BP. 1997. An equipment for the study of behavioural responses of mosquitoes to residual application of synthetic insecticides. *J Commun Dis* 29:225-234.
- Elliott R. 1964. Studies on the kinetic response of mosquitoes to chemicals. *Bull WHO* 31:657-667.
- Evans RG. 1993. Laboratory evaluation of the irritancy of bendiocarb, lambda-cyhalothrin, and DDT to *Anopheles gambiae*. *J Am Mosq Control Assoc* 9:285-293.
- Gerber EJ, Barnard DR, Ward RA. 1994. Manual for mosquito rearing and experimental techniques. No. 5. *Am Mosq Control Assoc Bull* (revised). Lake Charles, LA: AMCA, Inc.
- Gubler DJ. 1998. Resurgent vector-borne diseases as a global health problem. *Emerg Infect Dis* 4:442-450.
- Haynes KF. 1988. Sublethal effects of neurotoxic insecticides on insect behavior. *Annu Rev Entomol* 33:149-168.
- Kline DL, Bernier UR, Posey KH, Barnard DR. 2003. Olfactometric evaluation of spatial repellents for *Aedes aegypti*. *J Med Entomol* 40:463-467.
- Klun JA, Debboun M. 2000. A new module for quantitative evaluation of repellent efficacy using human subjects. *J Med Entomol* 37:177-181.
- Klun JA, Khrimian A, Margaryan A, Kramer M, Debboun M. 2003. Synthesis and repellent efficacy of a new chiral piperidine analog: comparison with Deet and Bay-repel activity in human-volunteer laboratory assays against *Aedes aegypti* and *Anopheles stephensi*. *J Med Entomol* 40:293-299.
- Klun JA, Schmidt WF, Debboun M. 2001. Stereochemical effects in an insect repellent. *J Med Entomol* 38:809-812.
- Kramer WL, Mulla MS. 1979. Oviposition attractants and repellents of mosquitoes: oviposition response of *Culex* mosquitoes to organic infusions. *Environ Entomol* 8: 1111-1117.
- McGovern TP, Schreck CE, Jackson J. 1978. Mosquito repellents: alicyclic amides as repellents for *Aedes aegypti* and *Anopheles quadrimaculatus*. *Mosq News* 38: 346-349.
- Najera JA, Zaim M. 2003. Malaria vector control: decision making criteria and procedures for judicious use of insecticides. Document WHO/CDS/WHOPES/2002.5 Rev.1. Geneva, Switzerland: World Health Organization.
- Roberts DR, Alecrim WD, Tavares AM, McNeill KM. 1984. Influence of physiological condition on the behavioral response of *Anopheles darlingi* to DDT. *Mosq News* 4:357-361.
- Roberts DR, Chareonviriyaphap T, Harlan HH, Hsieh P. 1997. Methods for testing and analyzing excito-repel-



- lency responses of malaria vectors to insecticides. *J Am Mosq Control Assoc* 13:13–17.
- Rutledge LC, Collister DM, Meixsell VE, Eisenberg GH. 1983. Comparative sensitivity of representative mosquitoes (Diptera: Culicidae) to repellents. *J Med Entomol* 20:506–510.
- Rutledge LC, Echana NM, Gupta RK. 1999. Responses of male and female mosquitoes to repellents in the World Health Organization insecticide irritability test system. *J Am Mosq Control Assoc* 15:60–64.
- Sarkaria DS, AWA Brown. 1951. Studies on the responses of the female *Aedes* mosquitoes. Part II. The action of liquid repellent compounds. *Bull Entomol Res* 42:115–122.
- SAS Institute. 1999a. *Base SAS software*. SAS OnlineDoc, version 8, CD-ROM. Cary, NC: SAS Institute, Inc.
- SAS Institute. 1999b. *SAS/STAT software*. SAS OnlineDoc, version 8, CD-ROM. Cary, NC: SAS Institute, Inc.
- Shreck, CE, McGovern TP. 1989. Repellents and other personal protection strategies against *Aedes albopictus*. *J Am Mosq Control Assoc* 5:247–250.
- Sungvornyothin S, Chareonviriyaphap T, Prabaripai A, Trirakhupt V, Ratanatham S, Bangs MJ. 2001. Effects of nutritional and physiological status on behavioral avoidance of *Anopheles minimus* (Diptera: Culicidae) to DDT, deltamethrin and lambda-cyhalothrin. *J Vector Ecol* 26:202–215.
- WHO [World Health Organization]. 1970. Instructions for determining the irritability of adult mosquitoes to insecticides. *Tech Rep Ser Annex* 17:158–164.
- WHO [World Health Organization]. 1998. Test procedures for insecticide resistance monitoring in malaria vectors, bio-efficacy and persistence of insecticides on treated surfaces. Report of the WHO Informal Consultation, 1998 September 28–30. Document WHO/CDS/CPC/MAL/98.12. Geneva, Switzerland: World Health Organization.
- WHO [World Health Organization]. 1999. Prevention and control of dengue and dengue hemorrhagic fever. WHO Regional Publication, SEARO No. 29. 134 p.
- Xue RD, Ali A, Barnard DR. 2003. Laboratory evaluation of toxicity of 16 insect repellents in aerosol sprays to adult mosquitoes. *J Am Mosq Control Assoc* 19:271–274.
- Yap HH, Jahangir K, Chong AS, Adanan CR, Chong NL, Malik YA, Rohaizat B. 1998. Field efficacy of a new repellent, KBR 3023, against *Aedes albopictus* (SKU-SE) and *Culex quinquefasciatus* (SAY) in a tropical environment. *J Vector Ecol* 23:62–68.
- Yap HH, Jahangir K, Zairi J. 2000. Field efficacy of four insect repellent products against vector mosquitoes in a tropical environment. *J Am Mosq Control Assoc* 16: 241–244.
- Zaim M, Guillet P. 2002. Alternative insecticides: an urgent need. *Trends Parasitol* 18:161–163.