

PORTABLE HYDROGEN MASER CLOCK TIME TRANSFER AT THE SUBNANOSECOND LEVEL

L. J. Rueger, M. C. Chiu, S. D. Deines
Johns Hopkins University/Applied Physics Laboratory
Laurel, MD 20707

R. A. Nelson, J. T. Broomfield, C. O. Alley
Department of Physics and Astronomy, University of Maryland
College Park, MD 20742

ABSTRACT

A subnanosecond time transfer between the Johns Hopkins University Applied Physics Laboratory (JHU/APL) and the United States Naval Observatory (USNO) was carried out using a portable hydrogen maser. The maser was contained within a temperature controlled enclosure which was supported on pneumatic shock isolators inside an air-conditioned van. The comparisons of the portable maser time with the APL base station maser time used the National Bureau of Standards technique of dual balanced mixers with picosecond resolution.

I. INTRODUCTION

Time transfers between major time and frequency laboratories have been accomplished via portable cesium clocks for the past 15 to 20 years. In more recent times, GPS common view time transfers have been utilized at a great savings in time and operational expense. The GPS transfers, however, are based on differential measurements over periods of several days. Portable clocks are still used to provide an absolute time difference measurement. It is customary to use cesium frequency standards for this function.

The high precision of hydrogen masers, in the range of a few parts in 10^{15} , has been recognized for several years^[1-4]. However, there has been no attempt to use these standards to transfer time as a portable clock. Few laboratories could benefit from comparisons of time at the subnanosecond level. APL, NBS and the USNO are among the few. Four portable clock experiments using a hydrogen maser were performed over a three day period in July 1987. This paper describes these experiments and discusses the results.

II. BACKGROUND

Over the past 28 years, the Johns Hopkins University Applied Physics Laboratory (JHU/APL) has maintained an atomic based frequency and time standard facility in support of research and development activities in precision time and frequency measurements for a number of government agencies. To satisfy DOD and non-DOD traceability requirements, these in-house standards have been linked over the years by various means to the United States Naval Observatory (USNO) and National Bureau of Standard (NBS) reference clocks and frequencies. For the last nine years, JHU/APL frequency and time standards have been linked via the United States Naval Observatory to the Bureau International de L'Heure (BIH) and contribute to the international definition of Coordinated Universal Time (UTC).

The APL facility currently has an ensemble of five hydrogen masers and one commercial Hewlett-Packard option 4 cesium standard. Since January 1986, the day to day link of these standards to other laboratories has been through common view monitoring of GPS satellites with an NBS designed GPS receiver. The APL GPS receiver is driven directly from the APL master clock hydrogen maser, NR6. The GPS antenna has a clear 360° view

Report Documentation Page

Form Approved
OMB No. 0704-0188

Public reporting burden for the collection of information is estimated to average 1 hour per response, including the time for reviewing instructions, searching existing data sources, gathering and maintaining the data needed, and completing and reviewing the collection of information. Send comments regarding this burden estimate or any other aspect of this collection of information, including suggestions for reducing this burden, to Washington Headquarters Services, Directorate for Information Operations and Reports, 1215 Jefferson Davis Highway, Suite 1204, Arlington VA 22202-4302. Respondents should be aware that notwithstanding any other provision of law, no person shall be subject to a penalty for failing to comply with a collection of information if it does not display a currently valid OMB control number.

1. REPORT DATE DEC 1987	2. REPORT TYPE	3. DATES COVERED 00-00-1987 to 00-00-1987			
4. TITLE AND SUBTITLE Portable Hydrogen Maser Clock Time Transfer at the Subnanosecond Level		5a. CONTRACT NUMBER			
		5b. GRANT NUMBER			
		5c. PROGRAM ELEMENT NUMBER			
6. AUTHOR(S)		5d. PROJECT NUMBER			
		5e. TASK NUMBER			
		5f. WORK UNIT NUMBER			
7. PERFORMING ORGANIZATION NAME(S) AND ADDRESS(ES) Johns Hopkins University, Applied Physics Laboratory, Laurel, MD, 20707		8. PERFORMING ORGANIZATION REPORT NUMBER			
9. SPONSORING/MONITORING AGENCY NAME(S) AND ADDRESS(ES)		10. SPONSOR/MONITOR'S ACRONYM(S)			
		11. SPONSOR/MONITOR'S REPORT NUMBER(S)			
12. DISTRIBUTION/AVAILABILITY STATEMENT Approved for public release; distribution unlimited					
13. SUPPLEMENTARY NOTES Proceedings of the Nineteenth Annual Precise Time and Time Interval (PTTI) Applications and Planning Meeting, Redondo Beach, CA, 1-3 Dec 1987					
14. ABSTRACT see report					
15. SUBJECT TERMS					
16. SECURITY CLASSIFICATION OF:			17. LIMITATION OF ABSTRACT Same as Report (SAR)	18. NUMBER OF PAGES 28	19a. NAME OF RESPONSIBLE PERSON
a. REPORT unclassified	b. ABSTRACT unclassified	c. THIS PAGE unclassified			

above 10° from the horizon on a position known to an uncertainty of a few centimeters relative to a prime Defense Mapping Agency (DMA) survey point in the east coast geodetic survey. Prior to the GPS link, a portable Cs standard was used on a weekly trip between APL and the United States Naval Observatory, approximately 72 km (45 miles) round trip, with clock transfer closures typically in the 5 to 10 nanosecond range. The clock transfer closure refers to a laboratory time measurement of the portable Cs clock operating in a curbside vehicle before and after a round trip between APL and USNO, using a straight line interpolation.

Since the Cs standard clock transfers had been so successful in the past, it was proposed to use a hydrogen maser clock known to have stabilities far superior to the Cs clocks as a portable clock. The size of the hydrogen maser with portable standby power is considerably larger than the Cs clock, so a larger vehicle is required. APL salvaged a surplus radio truck equipped with an auxiliary motor generator and air-conditioning unit and refitted the side access door to accommodate the large entry needed for the APL masers. A first experiment was tried in November 1985 in which a maser built by Sigma Tau for APL was mounted on shipping pads and an auxiliary precision measurement instrumentation rack was mounted inside the truck. The results of this first experiment were very encouraging; a curb to curb closure of less than 0.5 nanoseconds was measured.

This trip yielded much information on various techniques needed to perform such a precise time transfer. First, it was noted that the cables used to reach from the APL T& F Lab to the curbside portable clock, located on the outside of the building, were subject to delay changes depending on the cable temperatures (e.g., exposed to sunlight or in the shade of clouds). These delay changes could be as much as 1.2 nanoseconds on the 2-way, 200-ft cables. To alleviate this effect, the cable has been rerouted inside the building to a box on the wall outside nearest to the curb. Now there is only a 20-ft building to curb span exposed to the weather. A second major factor affecting our measurements occurred at the USNO. The USNO was using a microstepper to correct for the drift of their hydrogen maser (the USNO masers do not have automated tuning mechanisms which are incorporated into both the NR and Sigma Tau masers). It was found that in measuring the APL maser against USNO's maser with the microstepper in the circuit, there were peak to peak modulations of 200 picoseconds. This modulation disappeared when the two masers were measured directly. Since this time, USNO has improved its method of compensating for the drift rate of its masers by adjusting the maser internal synthesizer.

There were also other factors affecting the operation of the maser during the trip which were identified. These include temperature, vibration, and acceleration effects. Better control of these factors was considered essential in order to achieve the desired goal of transferring time between APL and USNO with 100 picosecond uncertainty.

III. DESCRIPTION OF EQUIPMENT

A. APL Truck

The air-conditioned truck used to transport the hydrogen maser carries a 15 kW single phase, 220 volt motor generator set for primary power during portable operations. The power supplied to the maser, the enclosure heater and box temperature control system is via an Uninterruptable Power System (UPS) capable of delivering 920 watts for up to 20 minutes. The UPS takes input power from the vehicle motor/generator and charges up a 70 volt battery; the battery feeds a crystal controlled 60 hertz oscillator and power amplifier. This arrangement removes all vehicle motor generator transients, spikes, and frequency variations from the electrical loads. There is a rack of precision time and frequency measurement instrumentation that can be carried in the van; this is identified as the 5 MHz system, and is described later. The APL Truck is shown in Figure 1.

B. Hydrogen Maser

The portable hydrogen maser clock used for the APL time transfers was designed and fabricated by Sigma Tau, Inc. for APL. This maser, designated ST1, is fairly small in size and mass compared to most types of masers. The Sigma Tau maser, however, is unique in its tuning capability. By modulation of the maser cavity frequency, the ST1 maser can tune without reference to another maser^[6]. This feature is a key factor in the performance of the portable hydrogen maser clock. Many disturbances to which the maser was subjected while being transported were essentially corrected internally through this self-tuning process. A picture of the ST1 maser is shown on the left in Figure 2, an NR maser is shown on the right.

C. Environmental Monitors and Controls

(i) Clock Enclosure

The portable clock must have a stable temperature. For a few parts in 10^{15} frequency stability, a temperature stability of about 0.1°C is needed. The APL van can be either air-conditioned or heated. Temperature is regulated with a thermostat which provides stability of a few degrees. To obtain greater temperature stability for the clock a special enclosure was constructed. The dimensions are 1.72 m high x 1.24 m wide x 0.93 m deep. This volume can accommodate either the Sigma Tau maser used in these experiments or the APL NR-series of masers. Air is drawn into the enclosure through a duct by two fans whose speeds can be regulated. An airflow of $0.15\text{ m}^3/\text{s}$ (315 CFM) was found to be satisfactory that allowed for both cooling of the air and removal of the 150 W maser heat dissipation. The interior temperature is controlled slightly above ambient room temperature by a commercial system manufactured by Watlow. Heat is added by a 49-cm long stainless steel heating element with blades mounted perpendicular to the axis. The maximum power is 1450 W at 120 V. The current to the heating element is provided by a silicon rectifier power supply that is regulated by a Watlow series "910" digital controller. The sensor is a platinum Resistor Temperature Device (RTD) placed on the surface of the maser. The controller has a microprocessor that has proportional-integral-derivative (PID) action. The PID parameters can be programmed on the face of the instrument.

Considerable effort was made to test this system in the laboratory to obtain the optimum combination of parameters. It was found that an internal temperature stability of 0.1°C could be maintained in the laboratory when the external temperature fluctuated by a few degrees. However, the road trips were undertaken on hot summer days when the air temperature exceeded 32°C . The van air conditioner was not able to provide sufficient cooling while the van was in motion on the longer trips described in this report. Consequently, the temperature within the clock enclosure actually varied by a degree or more during the trips and the full temperature control capability was not realized in these specific tests.

Several measurements were made on the temperature stability of the Sigma Tau maser while maintained at a constant temperature of $24.0 \pm 0.1^\circ\text{C}$ within the clock enclosure in the laboratory. The change in slope of the chart record for the 200 MHz system (described below) was measured for consecutive 1, 2, and 3-hour intervals over a time span of 72 hours to determine the stability and prediction of time keeping. Histograms of the data are presented in Figure 3. The standard deviation in the time change relative to a laboratory standard is about 25 ps over 1 hour.

The clock enclosure was also used to measure the temperature coefficient of the Sigma Tau maser. The temperature controller setpoint was raised from 24°C to 28°C and a new equilibrium was later observed. From the change in slope of the chart record for three trials it was found that the temperature coefficient was $1.8 \pm 0.6 \times 10^{-14}/^\circ\text{C}$. This result is consistent with earlier tests conducted in a small room whose temperature could

be regulated. It was also found that between 1 and 1 1/2 hours elapsed between the time when the temperature setpoint was changed and the clock responded by changing its frequency. This delay is due to a combination of the maser thermal time constants and the self-tuning feature of the maser.

The clock must also be protected from strong vibration. Shock isolation was obtained by mounting the enclosure on four pneumatic supports, each with a load rating of 150 to 600 lb, manufactured by Barry Controls. This required a special loading procedure. The clock enclosure was supported on wheels and a set of rails was constructed that can be erected to extend out the side of the van. The enclosure with the portable clock secured inside is lifted onto the rails by a forklift and the enclosure is rolled into the van onto a frame bolted to the floor. One rail has an inverted "vee" shape to index on grooved wheels on one side of the enclosure. A picture of this clock enclosure being loaded into the APL Truck is shown in Figure 4. When the clock is inside the van, the shock isolators are pressurized with a nitrogen cylinder, thereby raising the enclosure off the rails slightly, and the rails are removed. The shock system provided good high frequency vibration isolation during road trips. The pneumatic supports provided adequate lateral stability while limiting the vertical vibration to a few hertz with a maximum amplitude of about 2 cm.

Provision was also made to attach a pair of wheel assemblies to the outside of the clock enclosure to facilitate moving it in and out of the laboratory with the maser inside. The wheels are removed when the enclosure is supported by the forklift prior to being loaded onto the rails. The time required to move the system out of the laboratory and load it into the van is between 30 and 45 minutes.

(ii) Van Velocity

Provision was made to have a complete record of the van velocity over the duration of the trip, in order to apply small relativity corrections where applicable in the reduction of the data. A small permanent magnet dc motor was mounted on a bracket that could pivot about a support clamp. A large rubber wheel was attached to the motor axle. The device was bolted to the underside of the van so that the rubber wheel rested on the top of the van driveshaft. The electrical leads to the motor were extended through the truck floor where they could be connected to a strip chart recorder. When the van was in motion the motor, acting as a generator, produced a voltage directly proportional to the velocity. Periods when the van was moving in reverse or was at rest could also be identified. The resolution of the strip chart is about 2 mph. Figure 5 shows the truck velocity for one of the portable clock experiment trips.

D. Measurement Systems

Three time and frequency stability measurement systems were used during the time transfer experiments. Having more than one measurement system was considered necessary both for redundancy and in accounting for any ambiguities in the more precise systems. These three systems included a 1 PPS signal system, a 5 MHz signal based system and a 200 MHz signal based system. Block diagrams of the systems are shown in Figures 6-8.

(i) 1 PPS System

The 1 PPS (Pulse Per Second) system (Figure 6) uses the 1 PPS signals from the portable clock (PC) maser and NR6 maser as the start and stop functions on an HP 5345 counter in the time interval mode. At least ten consecutive measurements are made and averaged for a precision of ± 0.3 nanoseconds.

(ii) 5 MHz Signal System

The 5 MHz signal system (see Figure 7) compares the 5 MHz output signals from ST1 and NR6 using a heterodyne method. The individual 5 MHz signals are mixed with the signal from a 5 MHz VCO (voltage controlled oscillator) with a 10 Hz offset. The resulting 10 Hz beats are then input to a counter which measures the time interval between the zero crossings. The resolution of this counter is 100 picoseconds, and with the multiplication factor the resolution is less than 0.1 picosecond. The ambiguity of this system is 200 nanoseconds. This system was placed in a portable rack to transport in the APL Truck with the hydrogen maser.

(iii) 200 MHz Signal System

The 200 MHz system compares the 5 MHz signals from PC (ST1) and NR6 after a multiplication to 200 MHz using a heterodyne method (see Figure 8). The 5 MHz signal from PC is input to one of our reference APL masers, offset in frequency by 5×10^{-8} . The 5 MHz signals from PC and the 5 MHz (1 to 5×10^{-8}) signal from the reference maser are mixed producing a 10 Hz beat. A similar procedure is performed with the 5 MHz signal from NR6. The two resulting 10 Hz beats are then measured by HP 5300 counters with a resolution of 1 microsecond. The overall precision of this system (accounting for the multiplication factor) is 0.05 picoseconds, and the ambiguity is 5 nanoseconds. However, during these experiments only a strip chart was used to record the data. The reading resolution for the strip chart was only 10 picoseconds.

As one can see, the three systems are both redundant and complementary. The 1 PPS system can measure time differences without ambiguity (at least to the second) but is rather coarse in resolution. The 5 MHz and 200 MHz systems have much finer resolution but have ambiguities which can be resolved with the 1 PPS system. In addition to measuring the time differences between NR6 and ST1 in the time transfer experiments, measurements were also made between NR6 and two other, undisturbed NR masers in APL's Time and Frequency Laboratory. This was to verify that NR6 did not experience any disturbances during the time transfers that might contaminate the data.

IV. ANALYSIS OF TRIPS

Four trips were made with the portable hydrogen maser in which closure times were measured. The general procedure for these trips is as follows. The PC (ST1 maser) in the clock enclosure was wheeled from the APL Time and Frequency Laboratory (located on the third floor) down to the first floor and outside onto the sidewalk. A forklift was then used to lift the maser up to the rails extending from the APL truck side door (as described in a previous section). It was then rolled into the APL Truck and secured. When the portable 5 MHz measurement system was used, it was loaded at this time. The APL Truck was then driven to the curb outside located nearest to the Time and Frequency Laboratory to measure the PC relative to NR6. The APL truck was parked in this location for a period of time to monitor the performance of PC, and to allow the PC maser to recover from any disturbances caused by the move. After transporting the PC it was again parked in this location for a period of time to measure its performance. Afterwards it was returned to the APL Time and Frequency Laboratory.

Four trips were made between July 29 and July 31. The routes for the four trips are illustrated in Figure 9. A more detailed description of the individual trips is given below.

A. Trip 1

The first trip was made from APL curbside, on Johns Hopkins Road, across Route 29, along local roads to MD-216 and I-95. The route proceeded south to the MD-212 cloverleaf

at Calverton and returned over the same path to APL. The trip took about 35 minutes, covering 34.4 km (21.6 miles), and provided a clock closure of $+140 \pm 10$ picoseconds as measured by the 200 MHz system. A strip chart display of Trip 1 and Trip 2 using the 200 MHz measurement system is shown in Figure 10 as the left interrupted trace. The right trace in Figure 10 is another maser also compared to the NR6 house standard to verify that NR6 provided a stable reference during the various trips. The 1 PPS system measurement was consistent within its known resolution limits. A measurement on the 5 MHz system was not taken in the beginning of the trip. Figure 5 shows the truck velocity data for this trip.

B. TRIP 2

The same route as for trip 1 was followed and the trip time between departure and return was 36 minutes, providing a clock closure of $+110 \pm 10$ picoseconds as measured by the 200 MHz system (see Figure 10) and $+150$ picoseconds by the 5 MHz system. The 1 PPS system measured 0 ± 300 picoseconds, which is still consistent with the above measurements.

C. Trip 3

A measure of the clock stability during a road trip lasting 1.75 hours was provided by a trip from APL, proceeding south on Interstate Rt. 95, counter clockwise around the Washington Capital Beltway, and back. The total distance was 139.4 km (86.6 mi). The range of temperature within the clock enclosure was 1.5°C . As shown in Figure 11, a closure of 300 ± 10 picoseconds (using the 200 MHz system) was obtained between the times of disconnect and reconnect at curbside.

It is interesting to estimate what the effects of relativity would be for this trip. At an average speed of 80 km/h (50 mph) the time dilation effect would represent a loss of 17 ps of the portable clock compared to the stationary laboratory clock. Rt. 95 and the Beltway have average differences in elevation with respect to APL of -46 m and -76 m, respectively. The total gravitational redshift correction corresponds to a loss of 41 ps. In addition there is a Sagnac effect loss of 1 ps. The approximate total loss in time of the portable clock compared to the laboratory is thus 59 ps. If one is permitted to extrapolate the trend in the chart record after reconnect back to the point of disconnect, there is a shift to the right corresponding to a loss of about 60 ps. This agreement may be fortuitous, but it is significant that the technology of precise timekeeping has advanced so far that subtle relativity effects may be within the range of measurement for travel at the level of ordinary experience.

D. Trip 4

This trip was to the USNO and included a time transfer from the USNO curbside service. The trip took 3 hours and provided a time closure at APL of -200 ± 10 ps using the 200 MHz system. The 1 PPS system yielded -600 ± 300 picoseconds. The 5 MHz system was not used for the closure. A strip chart of this trip (using the 200 MHz system) is shown in Figure 12.

The trip started at curbside at APL as shown in Figure 13; proceeded to the curbside at USNO as shown in Figure 14.

Figure 15 shows the USNO time transfer in diagram form. The resultant time difference measured between USNO and NR6 (GPS) reference is 4247.8 ns via the time transfer using the portable hydrogen maser. As a comparison, the GPS time transfer between NR6 (GPS) and USNO for the same day was 4249 ± 4 ns. (The 4 ns error bar on our data is rather small compared to other facilities' GPS receivers. APL appears to be in a radio-quiet area and, in addition, the GPS receiver is driven by the hydrogen maser, a much more stable source than the cesiums normally used.)

V. PERFORMANCE OF APL TIME STANDARDS

The time keeping data from three NR continually tuned hydrogen masers is shown in Figure 16, relative to UTC (APL) for 250 days. The portable clock (ST1) time keeping data against NR6 is shown in Figure 17 for 250 days; the step in time resulted from adding a 46-foot cable to the portable clock to allow it to be moved to another room capable of accommodating the temperature controlled enclosure. The portable clock is continuously tuning against a selfcontained frequency modulation of the resonant cavity.

The APL master clock, the NBS master clock and the USNO master clock time keeping performances are compared against UTC (BIH) in Figure 18 via the GPS common view receiver systems. These plots show the relative stability as long term clocks of the portable clocks and the APL ensemble of hydrogen masers over a period before and after the time transfer experiments were performed.

VI. DISCUSSION OF RESULTS

It has been established that APL has a master clock system capable of keeping time with subnanosecond uncertainty over periods of days. The use of a hydrogen maser based clock as a portable clock has been demonstrated to provide subnanosecond performance over periods of hours in an environment available in an air-conditioned vehicle as evidenced from clock time closures.

Data taken via GPS receiver common monitoring over periods of months has provided data relating the performance of the APL master clock relative to precision master clocks at USNO and NBS, Boulder.

The hydrogen maser clock performance seems to have been degraded by a factor of 3 in the vehicle environment from the performance in the laboratory environment. Greater care in the control of temperature and vehicle accelerations should reduce the moving clock degradation factor significantly. In addition, a recently installed external power cable at APL will permit longer periods of clock stabilization and monitoring before and after a trip without having to rely on the van generator.

Future activities, more demanding on the maser clock performance, are planned. An additional time comparison between APL and USNO is planned. A new road test will also be performed in which longer monitoring and improved temperature control is expected.

Better control of these factors is considered essential in order to reach the performance needed for the maser's role in a forthcoming relativistic light propagation experiment in preparation at the University of Maryland. The optical link to be used in this experiment was described in a previous PTTI paper^[6].

ACKNOWLEDGEMENTS

We wish to thank Frank Desrosier of the University of Maryland for assistance in the design of the clock enclosure and personnel of the UM Machine Shop, in particular Ed Gorsky and Frank San Sebastian, for its construction. We also wish to thank Al Bates and Lee Stillman of the Applied Physics Laboratory for their assistance. This research was supported through the University of Maryland with the United States Naval Observatory and the Office of Naval Research under Navy Contract N00014-887-K-08 "Research on Laser Ranging and Advanced Time Transfer Techniques" and through the Johns Hopkins University on overhead funds to support the Time and Frequency Facility under Navy Contract N00039-87-C-5301.

REFERENCES

1. L. J. Rueger, "Characteristics of the NASA Research Hydrogen Maser," *Journal of the Institution of Electronics and Telecommunication Engineers*, Vol. 27, No. 11, 1981, pp. 493-500.
2. L. J. Rueger and M. C. Chiu, "Development of Precision Time and Frequency Systems and Devices at APL," *Johns Hopkins APL Technical Digest*, Vol. 6, No. 1, pp. 75-84.
3. L. J. Rueger and M. C. Chiu, "Long-Term Performance of The Johns Hopkins Built Hydrogen Maser," *IEEE Trans. on Instrumentation and Measurement*, Vol. IM-36, No. 2, June 1987, pp. 594-595.
4. A. G. Bates, M. T. Boies, M. C. Chiu, R. Kunski, and J. J. Suter, "Precision Time and Frequency Sources and Systems Research and Development at The Johns Hopkins University Applied Physics Laboratory," *Proc. of the Eighteenth Annual Precise Time and Time Interval Applications and Planning Meeting*, December 1986, pp. 55-70.
5. H. E. Peters and P. J. Washburn, "Atomic Hydrogen Maser Actions Oscillator Cavity and Bulb Design Optimization," *Proc. of the Sixteenth Annual Precise Time and Time Interval Applications and Planning Meeting*, December 1984, pp. 313-336.
6. C. O. Alley, J. D. Rayner, C. A. Steggerda, J. V. Mullendore, L. Small and S. Wagner, "Time Transfer Between the Goddard Optical Research Facility and the United States Naval Observatory Using 100 Picosecond Laser Pulses," *Proc. of the Fourteenth Annual Precise Time and Time Interval Applications and Planning Meeting*, December 1982, pp. 243-267.

LIST OF FIGURES

- Figure 1 APL Truck used for Portable Clock Experiments
- Figure 2 ST-1 Maser (left) and NR MASER
- Figure 3 ST-1 Maser Short Range Stability for 1, 2 and 3 Hour Intervals
- Figure 4 Clock Enclosure being loaded into APL Truck
- Figure 5 Sample Record of Velocity for Portable Clock Experiment (Trip 1)
- Figure 6 1 PPS Measurement System
- Figure 7 Measurement System Based on 5 MHz Signals
- Figure 8 Measurement System Based on 200 MHz Signals
- Figure 9 Routes for Portable Clock Experiments
- Figure 10 Strip Chart from 200 MHz Measurement System for Trips 1 and 2 (July 29, 1987)
- Figure 11 Strip Chart from 200 MHz Measurement System for Trip 3 (July 30, 1987)
- Figure 12 Strip Chart from 200 MHz Measurement System for Trip 4 (July 31, 1987)
- Figure 13 Curbside at APL
- Figure 14 Curbside at USNO
- Figure 15 Measured Time Differences between Standards for 31 July 1987 Time Transfer
- Figure 16 UTC (APL) - APL Masers
- Figure 17 UTC (APL) - ST1
- Figure 18 UTC (BIH) - UTC (i)



Figure 1 APL Truck used for Portable Clock Experiments

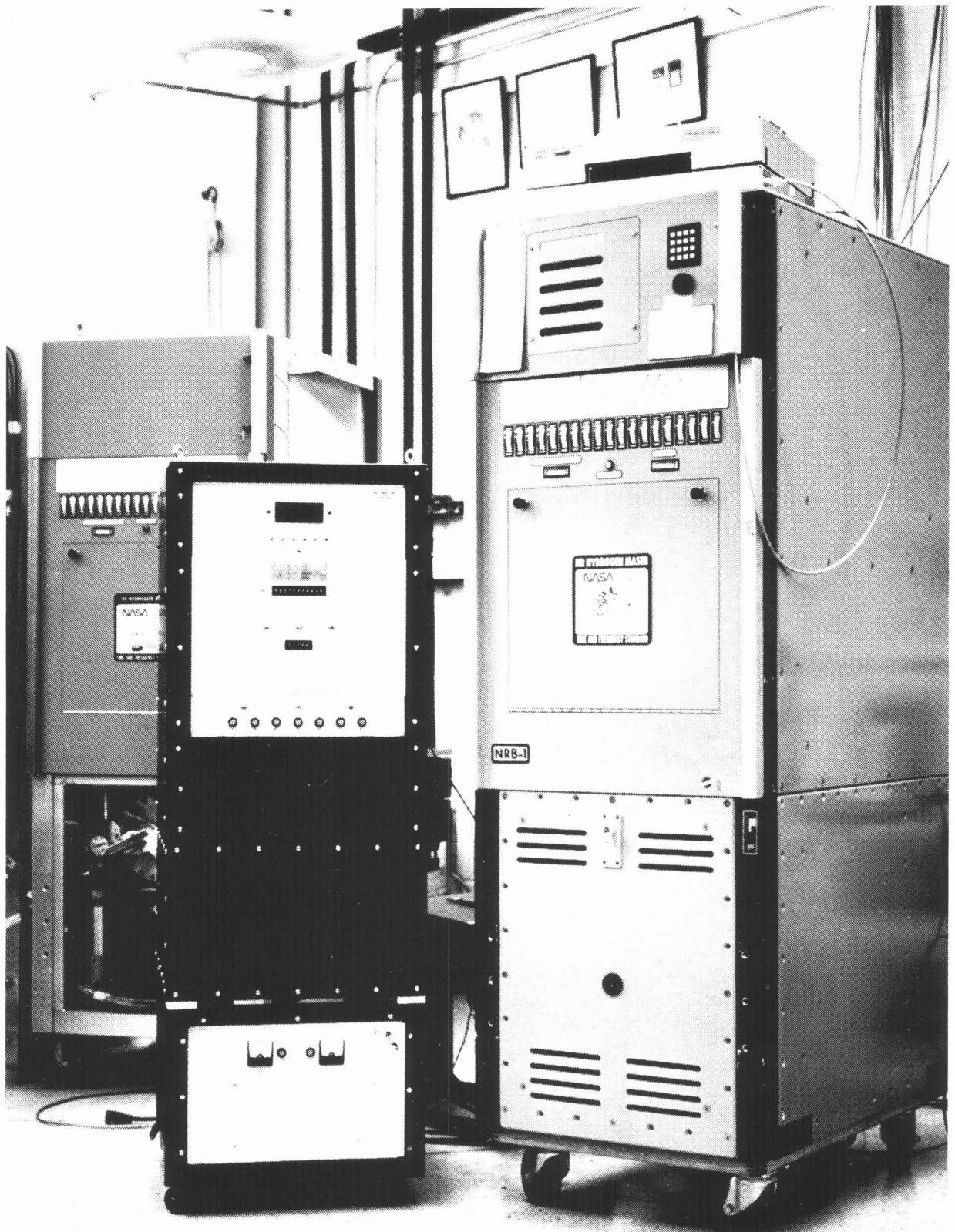
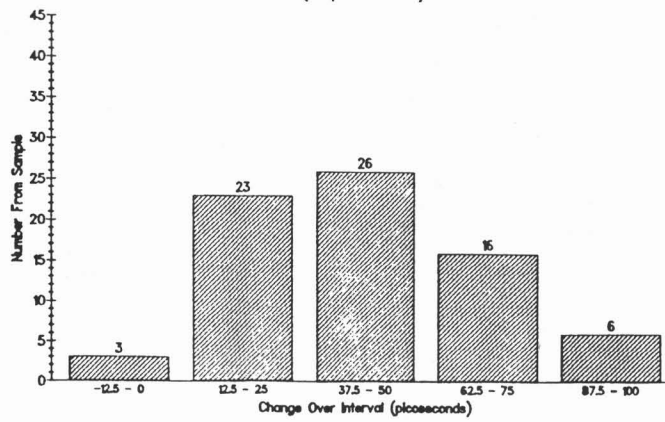
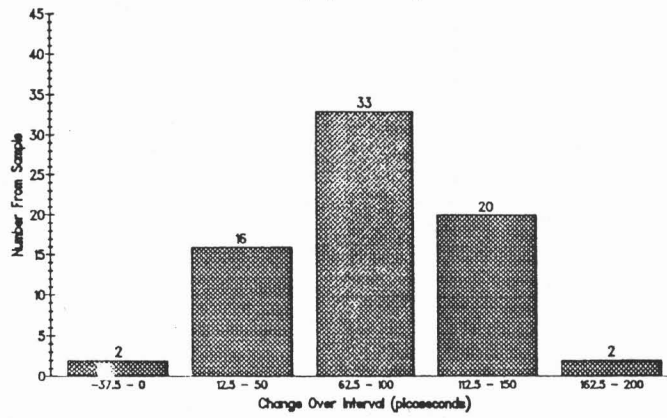

Figure 2 ST-1 Maser (left) and NR MASER

ST1 Maser Short Range Stability
One Hour Interval
(Sample Size of 74)



ST1 Maser Short Range Stability
Two Hour Interval
(Sample Size of 73)



ST1 Maser Short Range Stability
Three-Hour Interval
(Sample Size of 72)

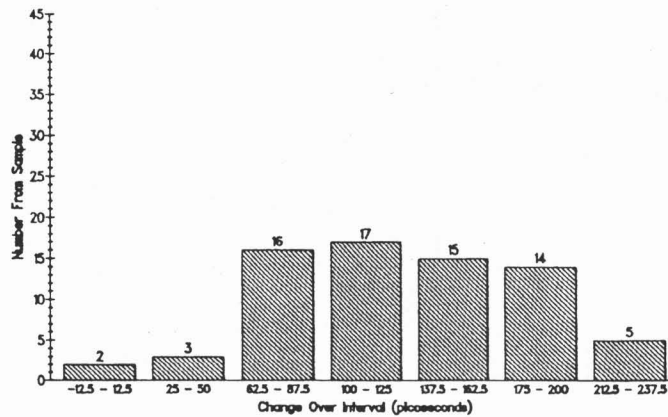

Figure 3 ST-1 Maser Short Range Stability for 1, 2 and 3 Hour Intervals

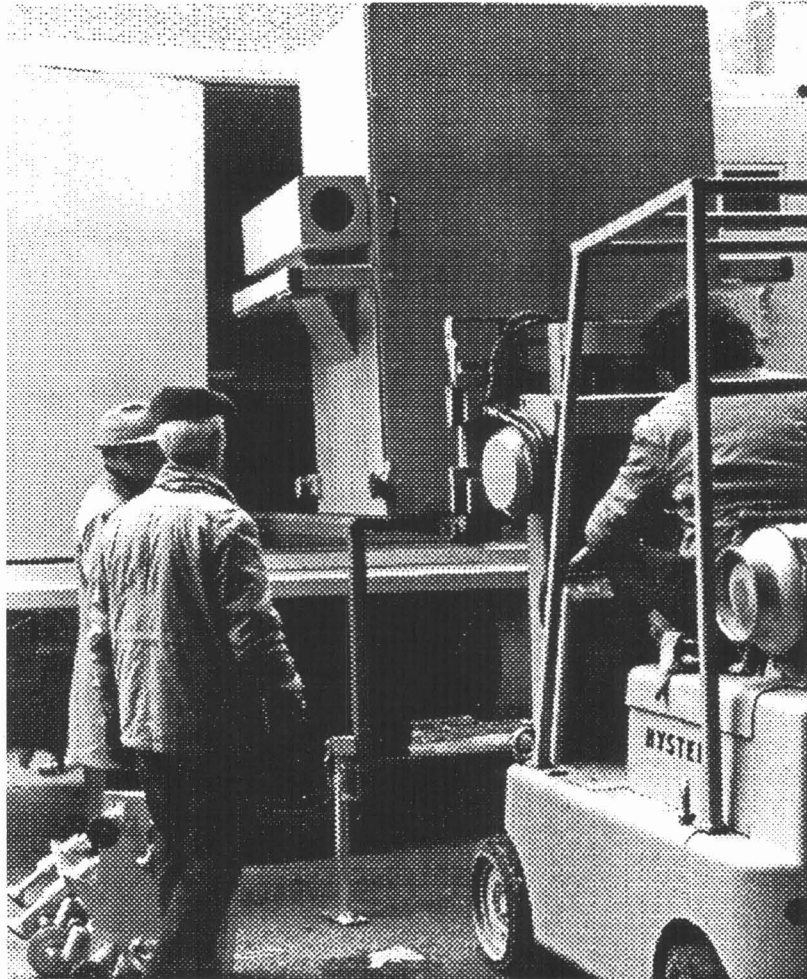

Figure 4 Clock Enclosure being loaded into APL Truck

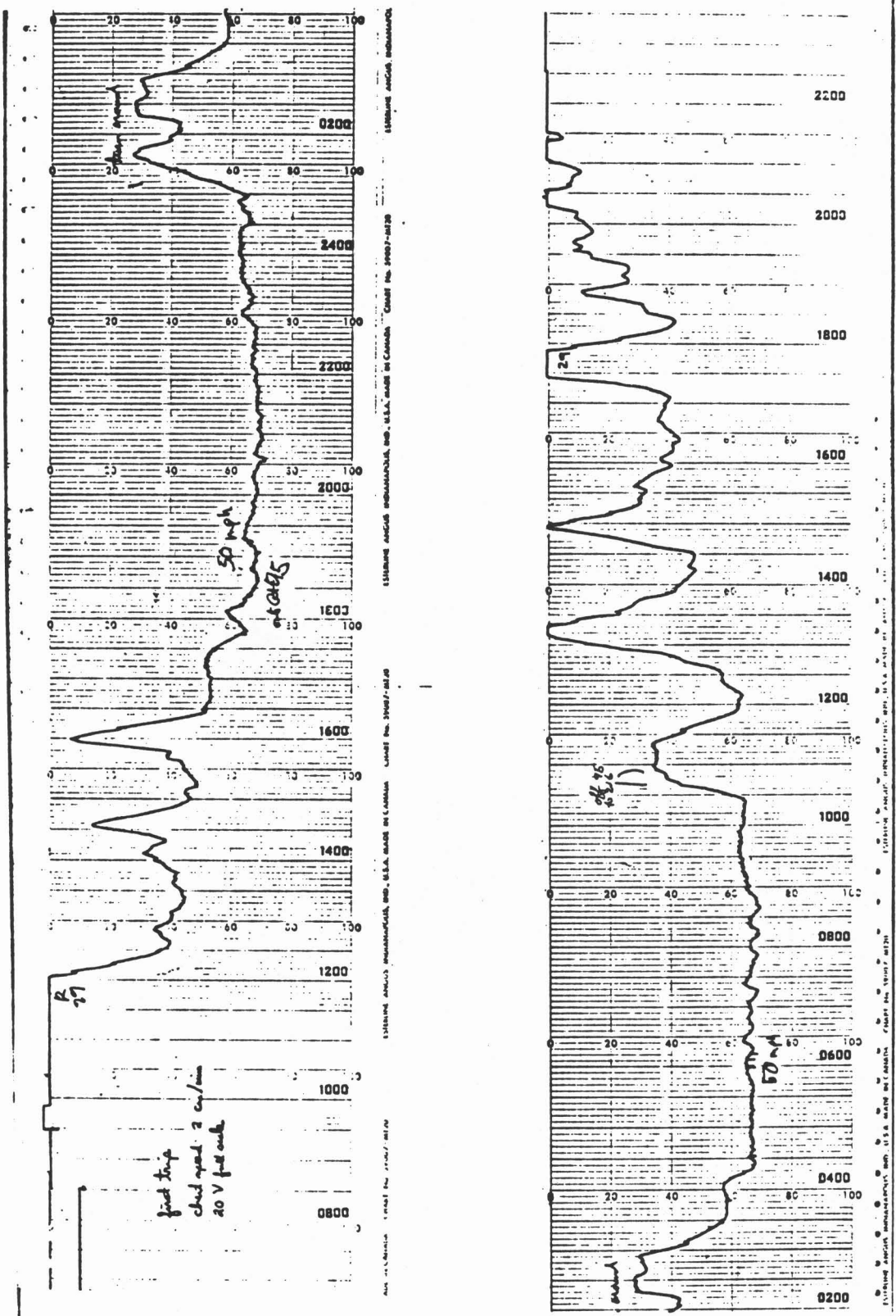
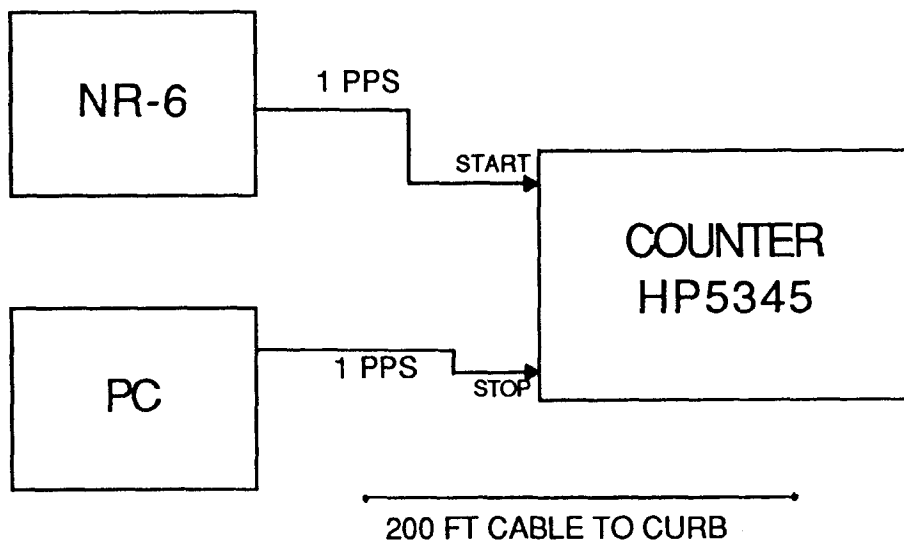
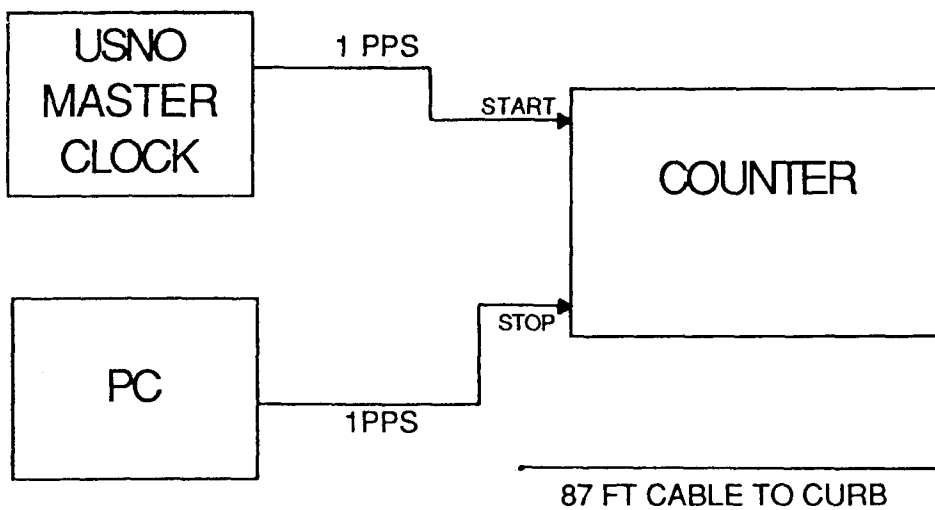

Figure 5 Sample Record of Velocity for Portable Clock Experiment (Trip 1)



**A) MEASUREMENT CONFIGURATION
AT APL**



**B) MEASUREMENT CONFIGURATION
AT USNO**

Figure 6. 1 PPS Measurement System

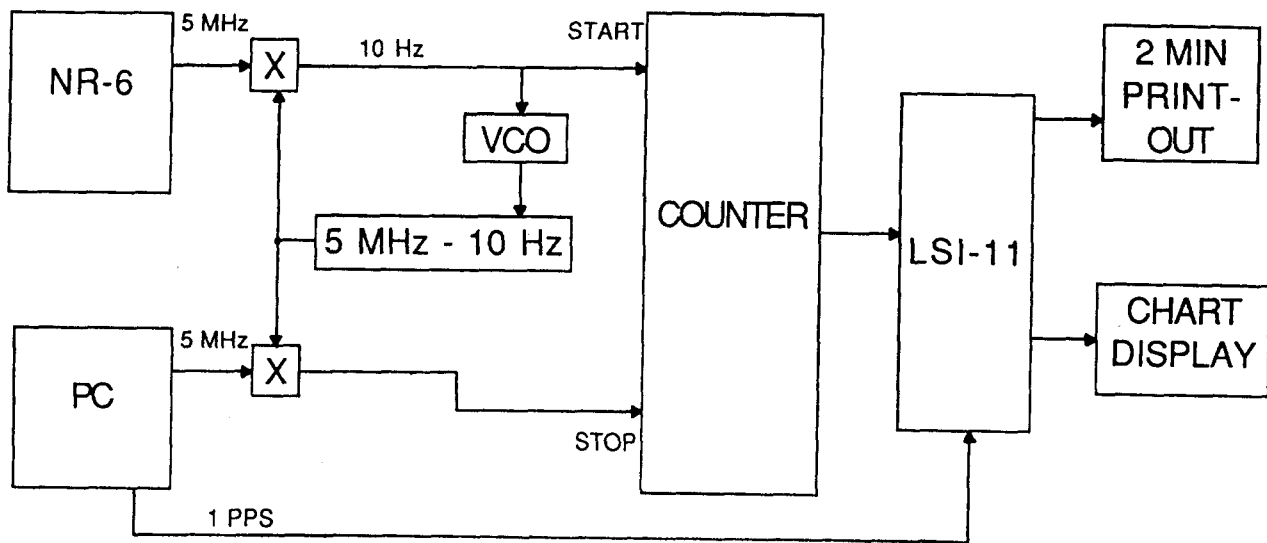

Figure 7. Measurement System Based on 5 MHz Signals

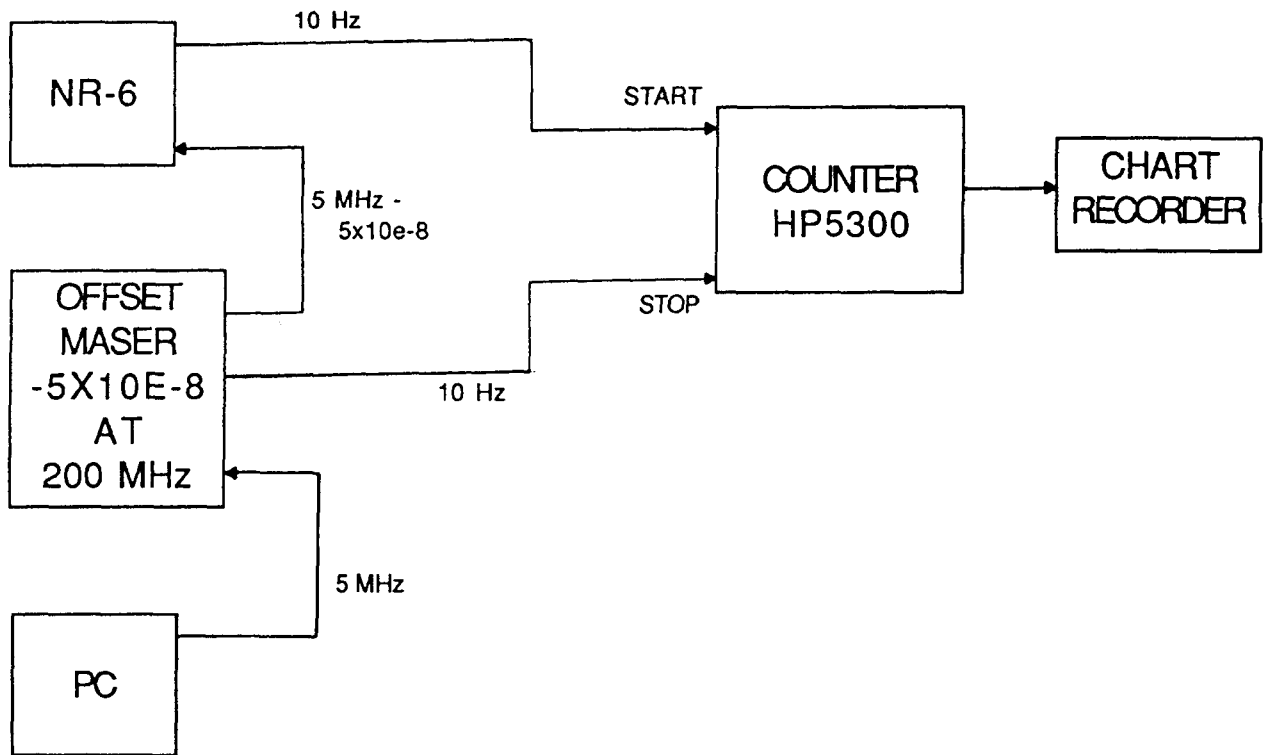

Figure 8. Measurement System Based on 200 MHz Signals

TRIP	PATH
1, 2
3	+++++
4	-----

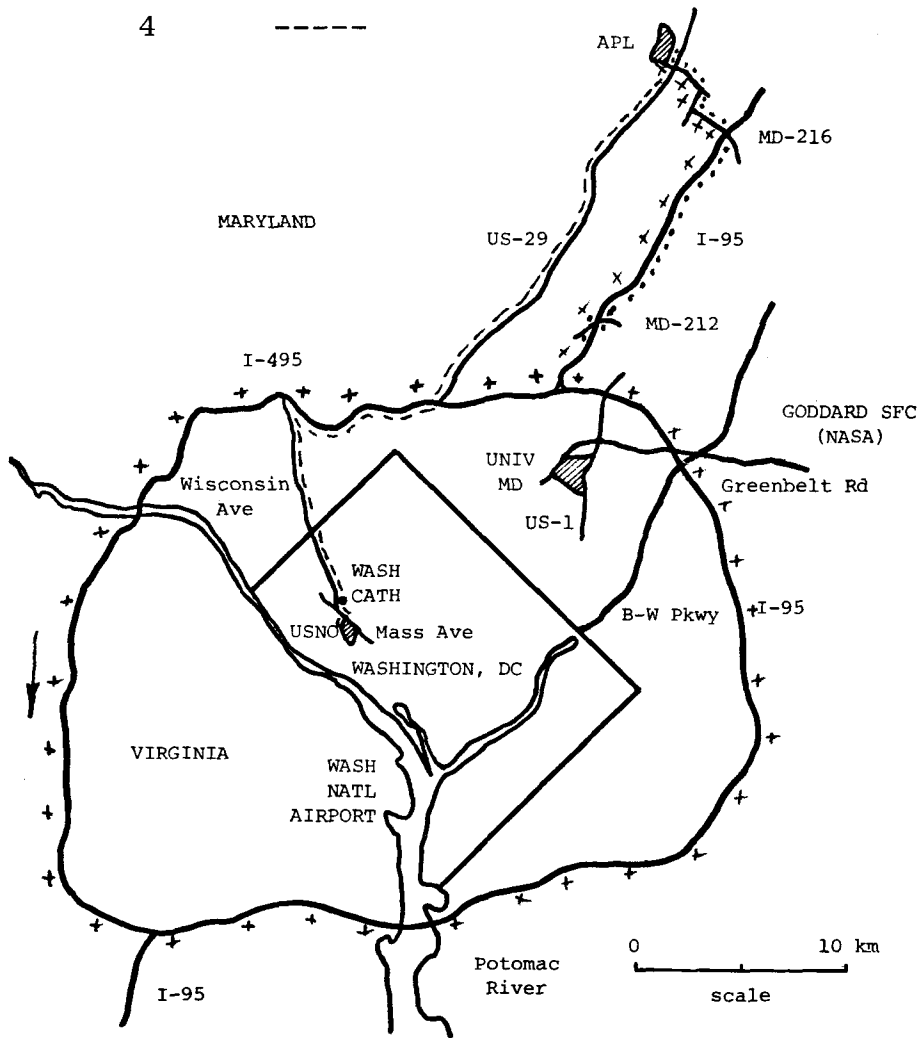

Figure 9. Routes for Portable Clock Experiments

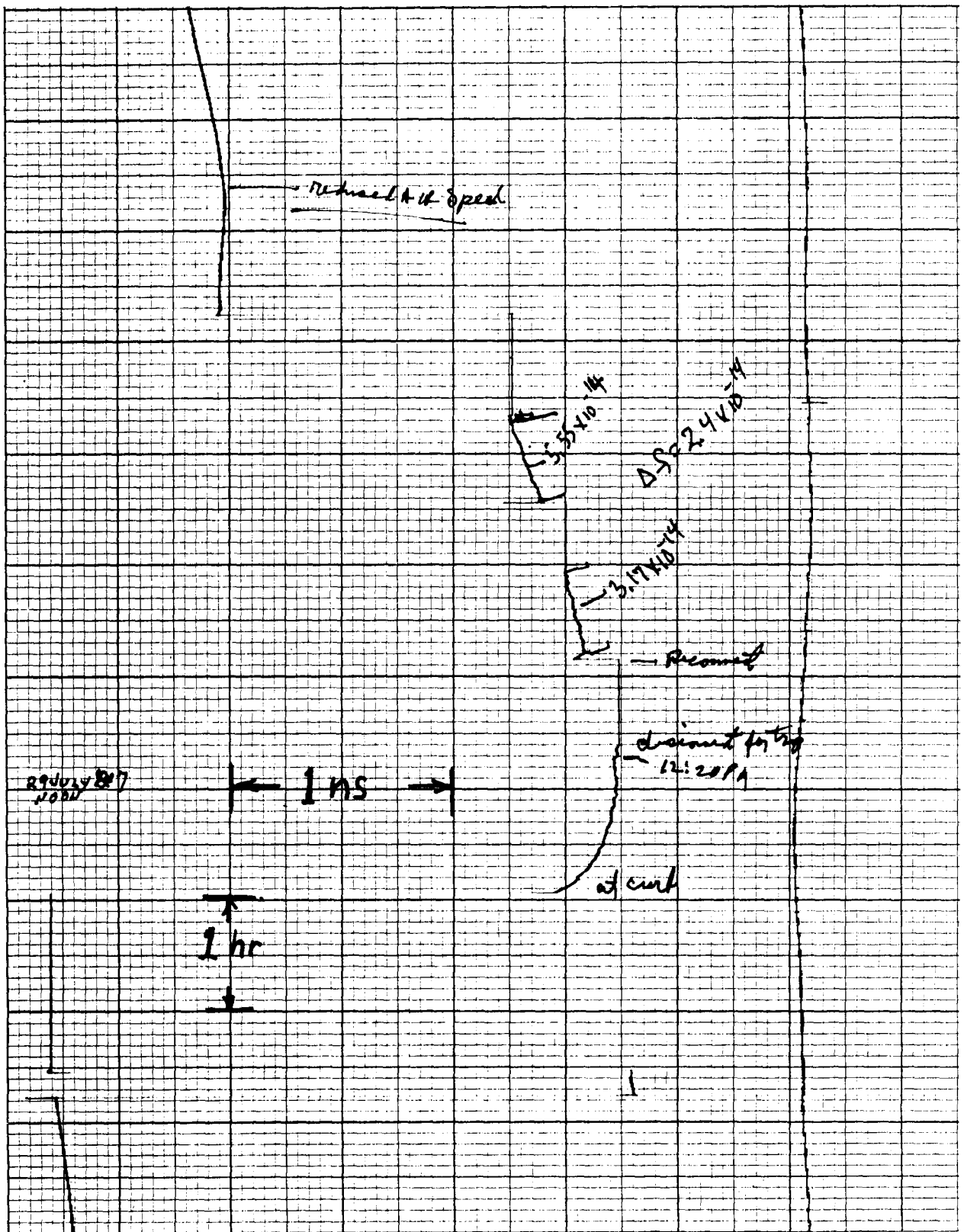

Figure 10. Strip Chart from 200 MHz Measurement System for Trips 1 and 2 (July 29, 1987)

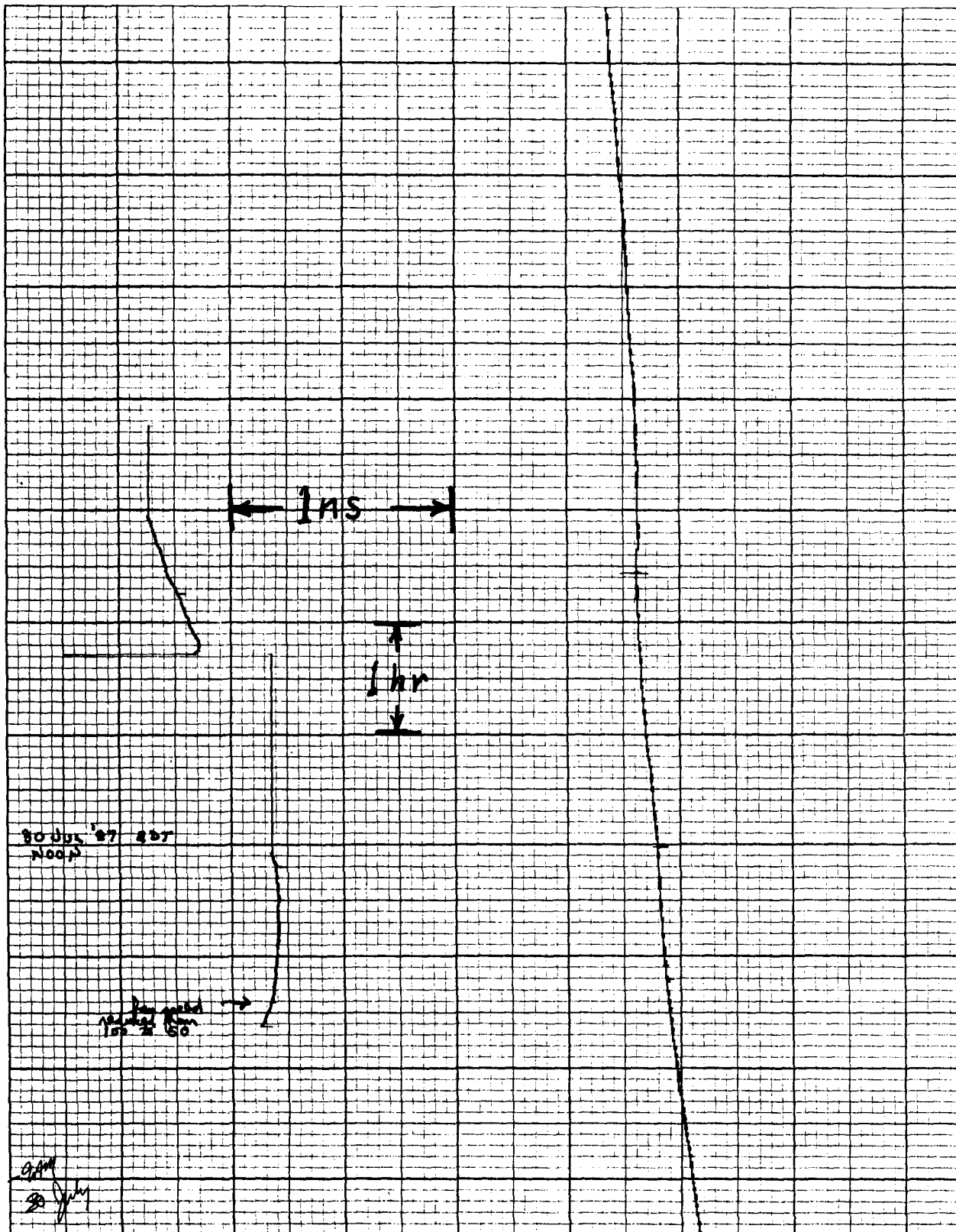

Figure 11. Strip Chart from 200 MHz Measurement System for Trip 3 (July 30, 1987)

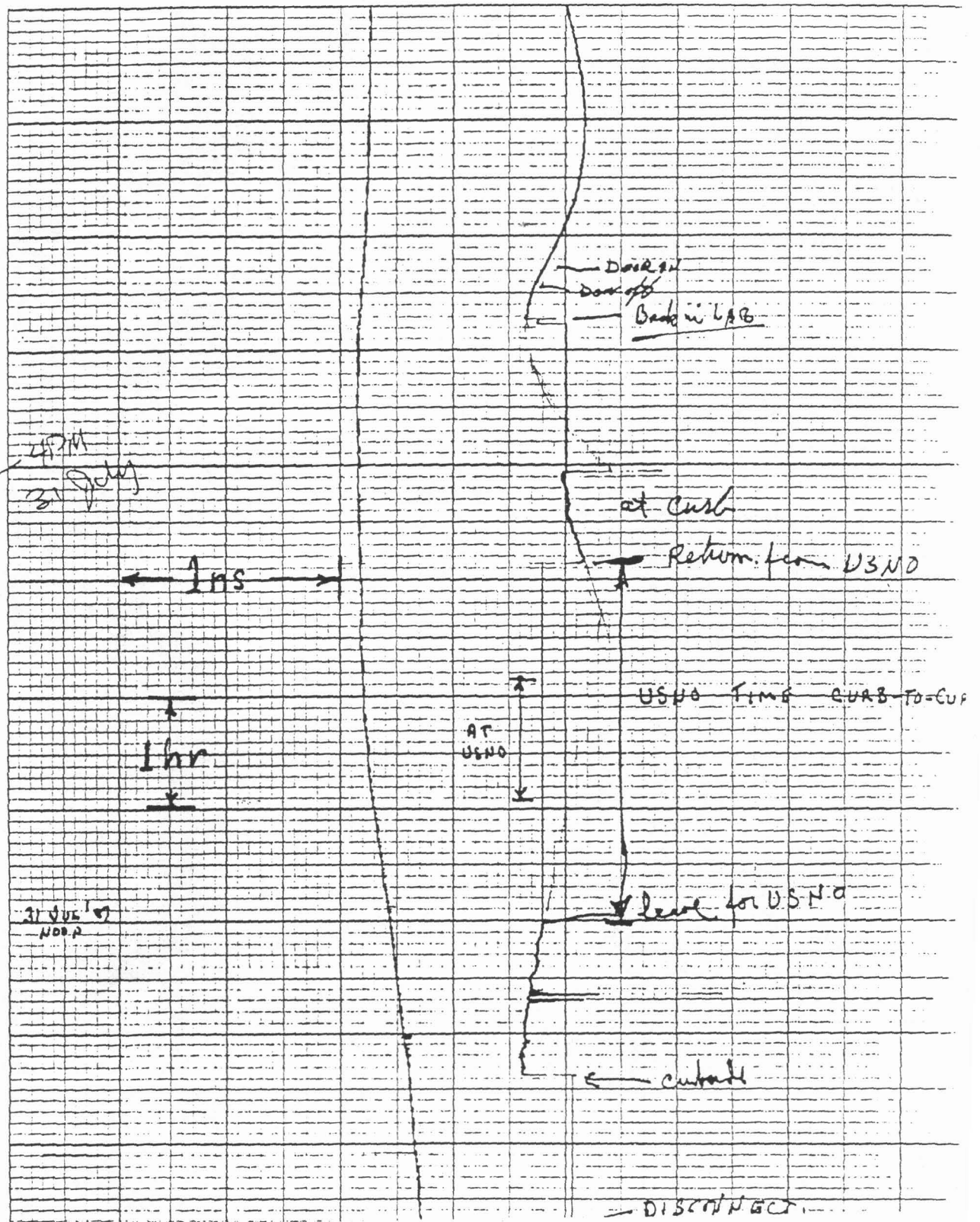

Figure 12. Strip Chart from 200 MHz Measurement System for Trip 4 (July 31, 1987)

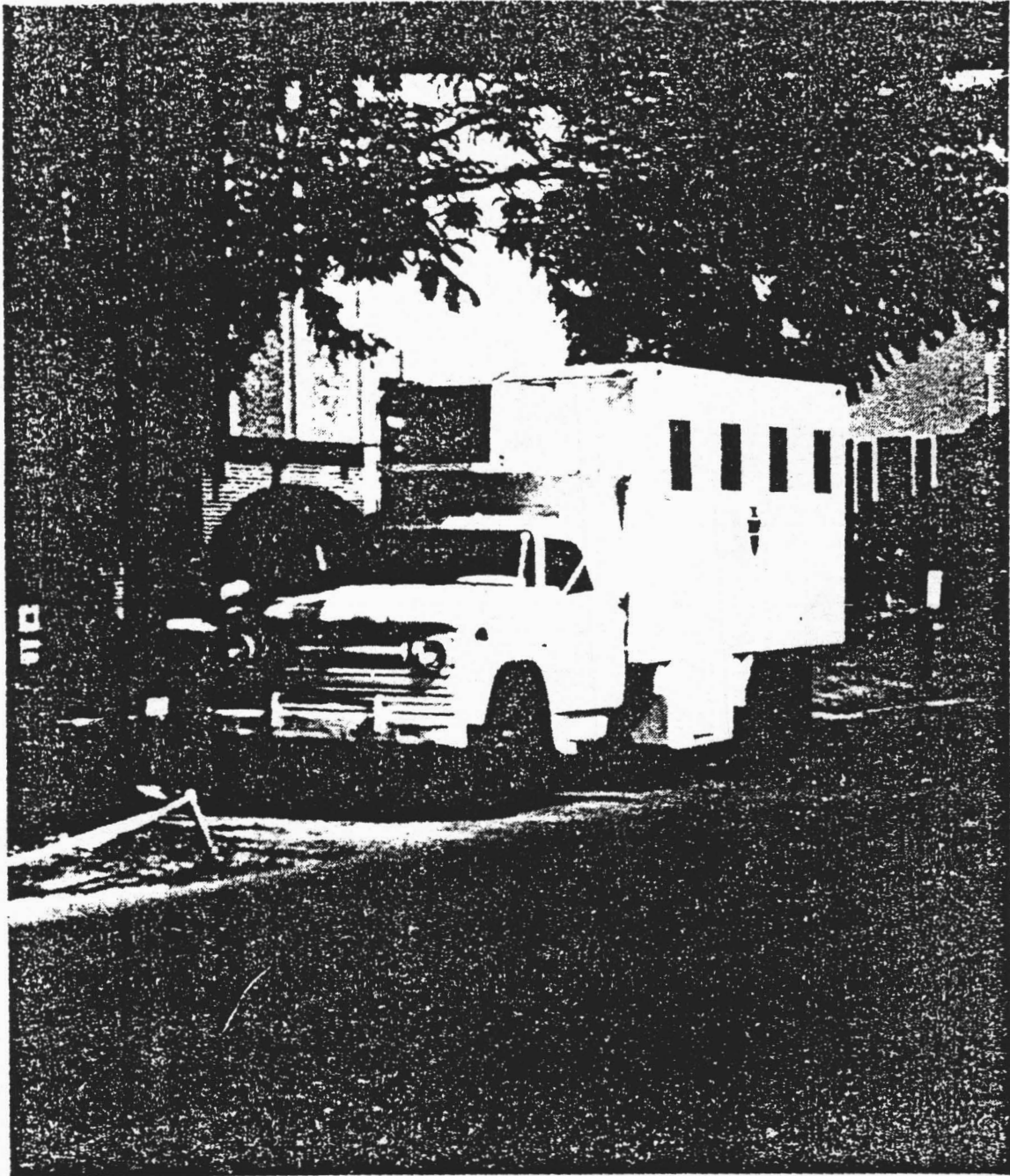

Figure 13. Curbside at APL

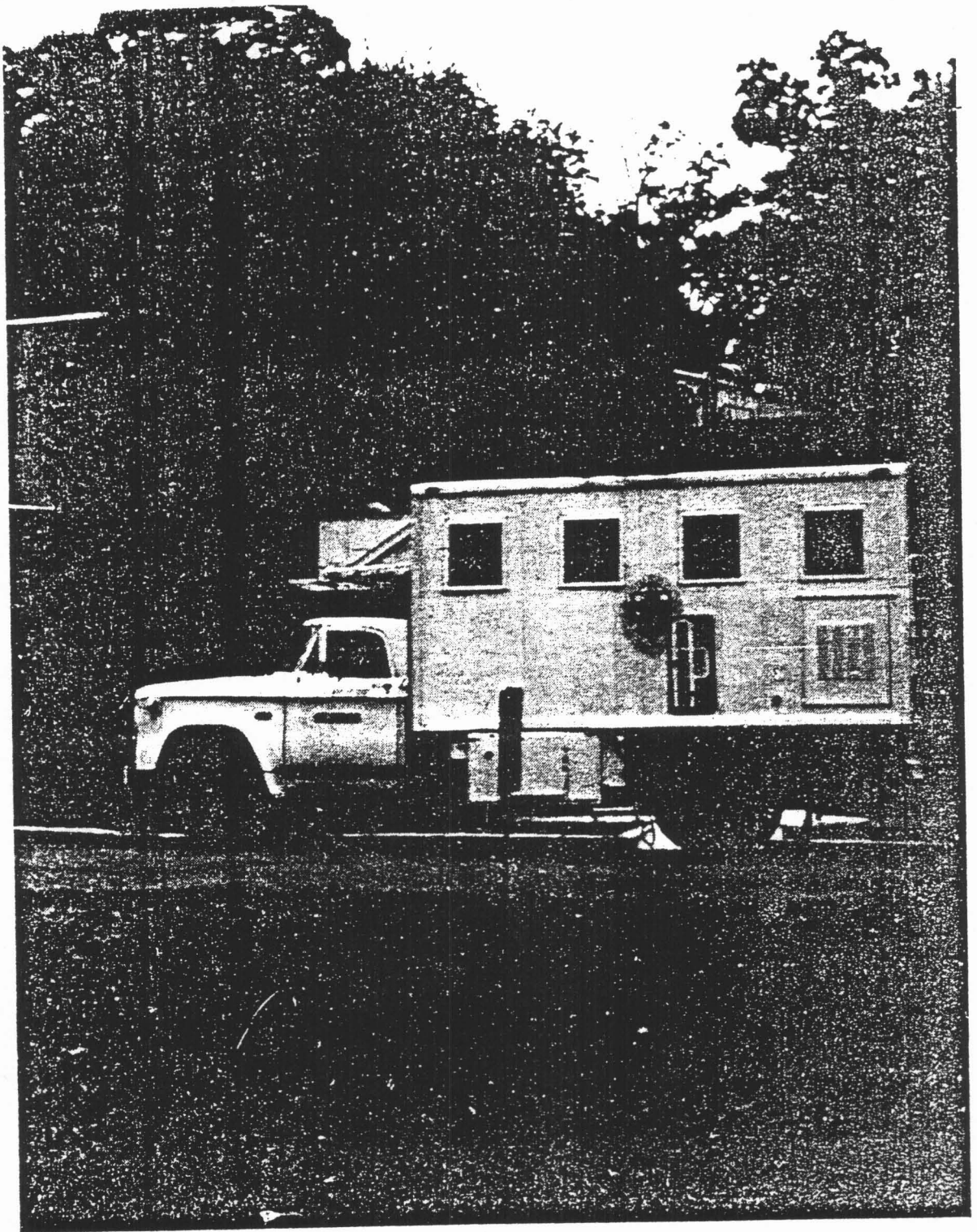
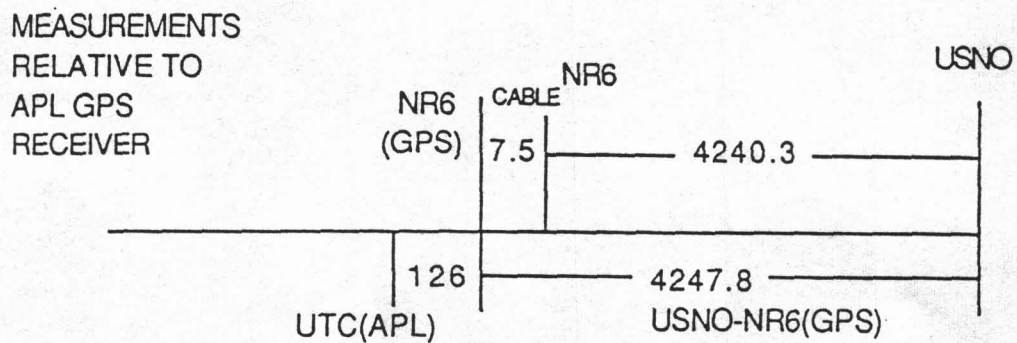
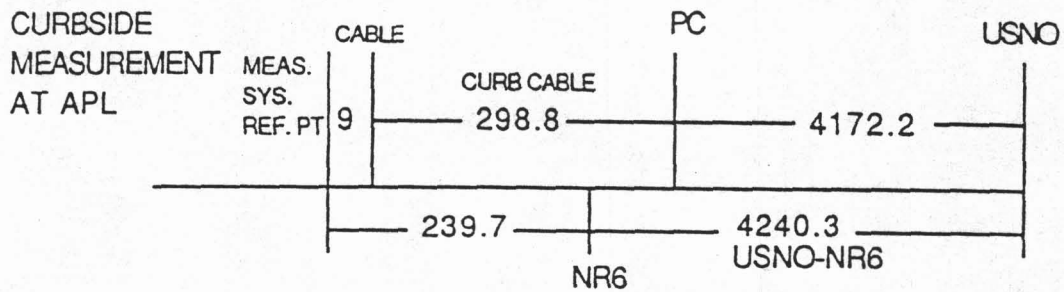
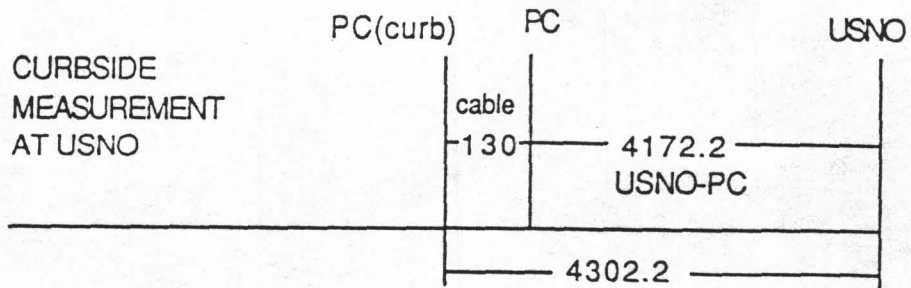

Figure 14. Curbside at USNO



NOTE:

ALL MEASUREMENTS GIVEN IN NANoseconds

USNO-NR6 VIA GPS RECEIVERS = 4249 ± 4 NANoseconds

Figure 15. Measured Time Differences between Standards for 31 July 1987 Time Transfer

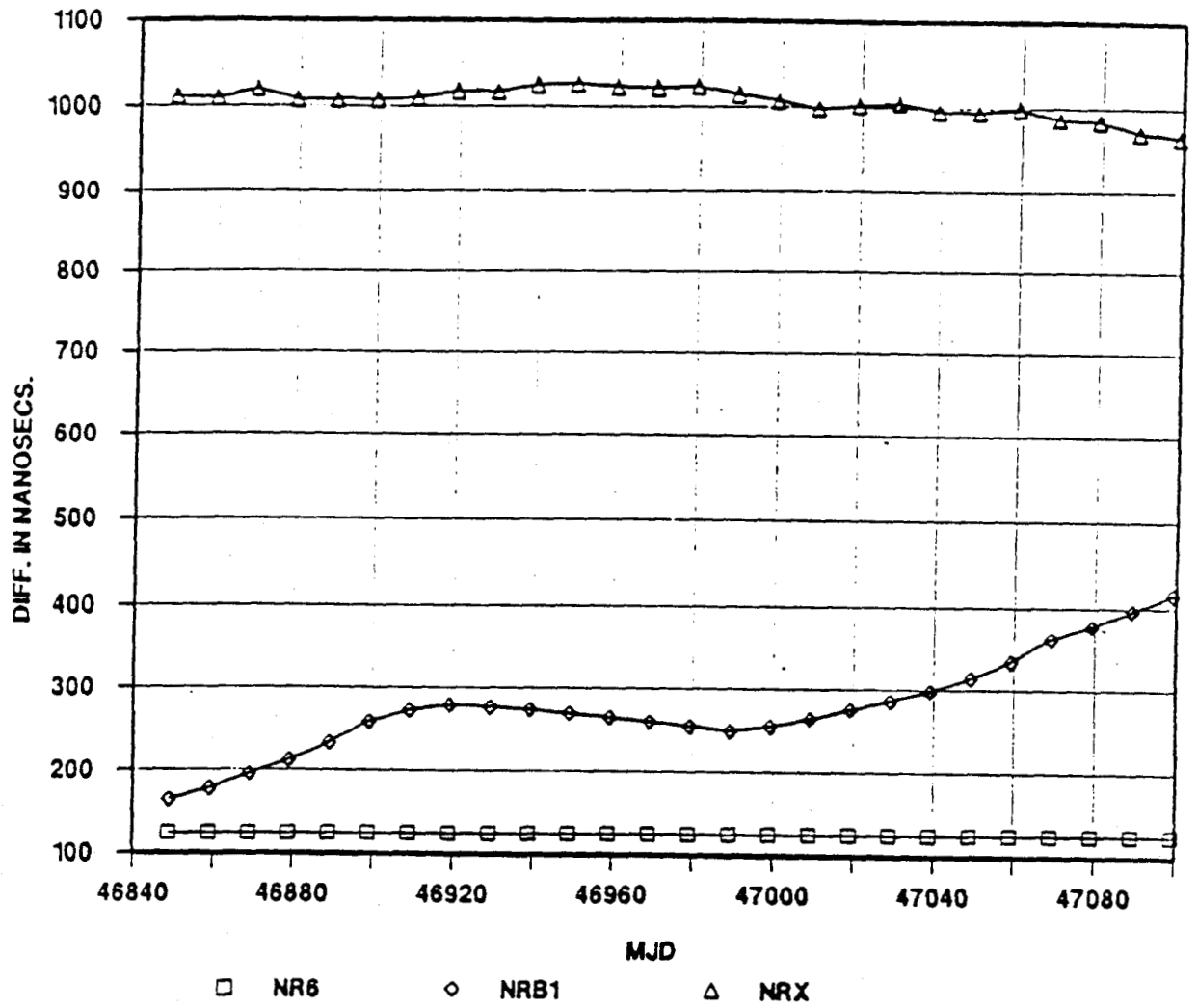

Figure 16. UTC (APL) - APL Masers

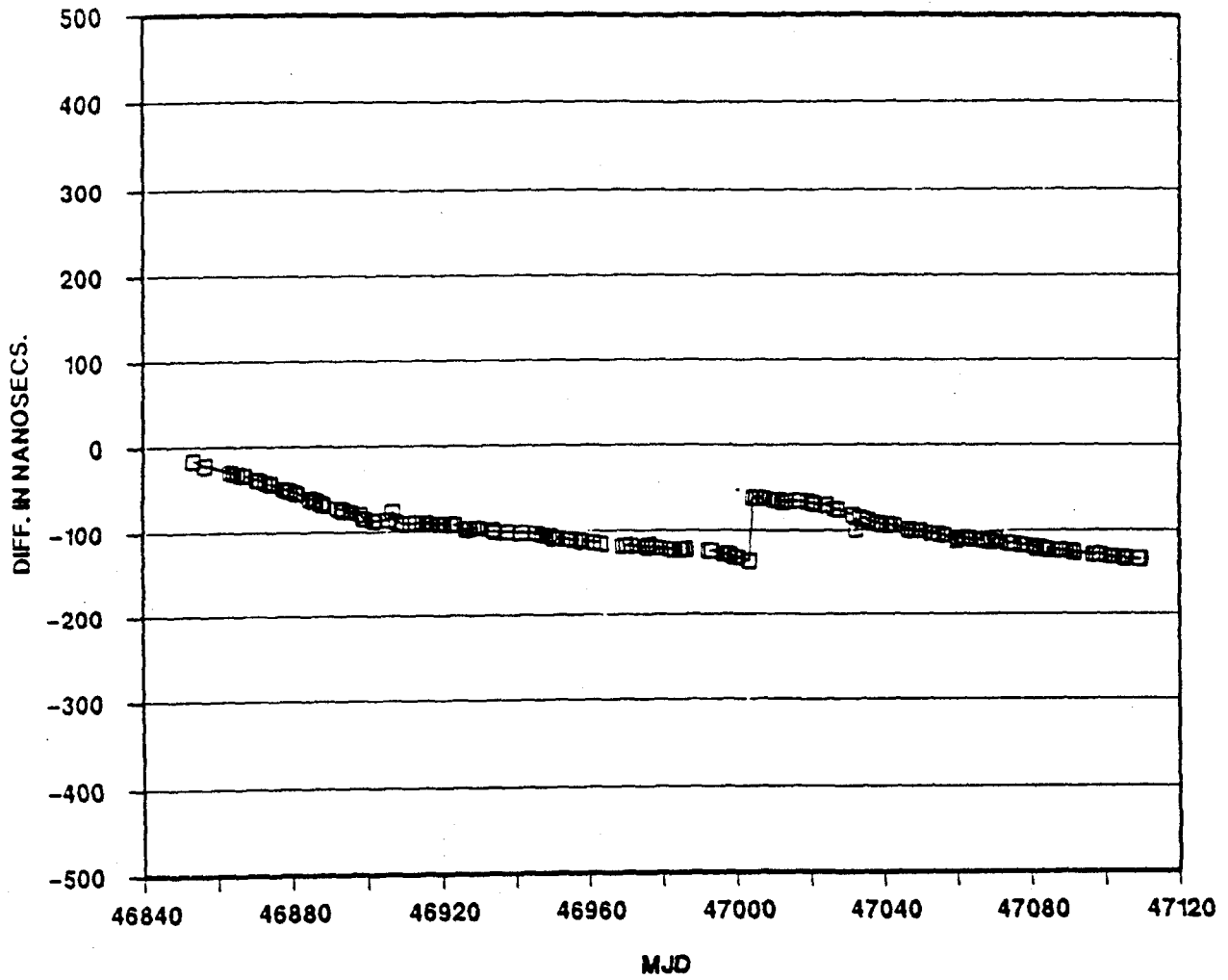

Figure 17. UTC (APL) - ST1

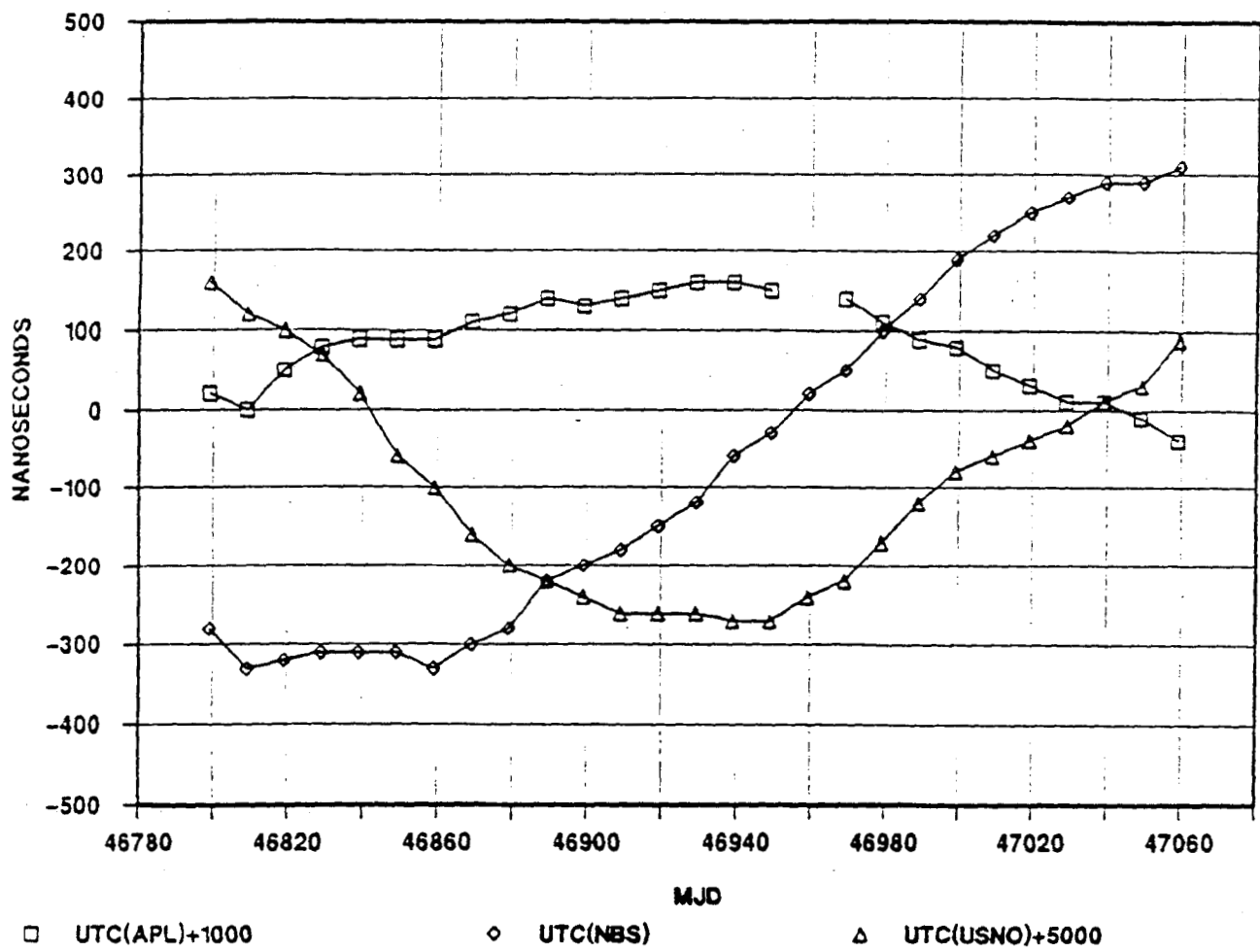

Figure 18. UTC (BIH) - UTC (i)

QUESTIONS AND ANSWERS

Gernot Winkler, United States Naval Observatory: This is a truly interesting and promising experiment with results that I would not have thought possible before the experiment. I took a rather dim view of the possibility of doing 100 picosecond or better time transfer with portable clocks. It does seem that the experiment looks promising.

Mr. Rueger: Our objective was to get our time base, compared to the USNO, to 100 picoseconds or better. I think that we are pretty close to doing that. We are preparing for a forthcoming relativistic measurement of light propagation in cooperation with the University of Maryland.