



Australian Government
Department of Defence
Defence Science and
Technology Organisation

A Review of Chemical Warfare Agent (CWA) Detector Technologies and Commercial-Off-The-Shelf Items

Rodi Sferopoulos

Human Protection and Performance Division
Defence Science and Technology Organisation

DSTO-GD-0570

ABSTRACT

This report provides a review of the open-source literature (unclassified) and information obtained from manufacturers regarding the technologies, including advantages and disadvantages, used in commercially available equipment currently employed for the detection of chemical warfare agents (CWAs) and toxic industrial chemicals (TICs). A brief description of the well-known, commercial-off-the-shelf instruments that employ these technologies is also provided.

RELEASE LIMITATION

Approved for public release

Published by

*Human Protection and Performance Division
DSTO Defence Science and Technology Organisation
506 Lorimer St
Fishermans Bend, Victoria 3207 Australia*

Telephone: (03) 9626 7000

Fax: (03) 9626 7999

© Commonwealth of Australia 2008

AR-014-414

March 2009

APPROVED FOR PUBLIC RELEASE

A Review of Chemical Warfare Agent (CWA) Detector Technologies and Commercial-Off-The- Shelf Items

Executive Summary

The ability to rapidly detect, identify and monitor chemical warfare agents (CWAs) is imperative for the efficient use of both military and civilian defence resources. This knowledge allows the severity and extent of a hazard to be assessed so that areas that are clean or contaminated can be identified. Furthermore, the information acquired by these systems provides advice to military commanders and first responders, regarding the donning of individual protective equipment (IPE), sampling, handling and analysis procedures as well as medical countermeasures, should the need arise.

An ideal detector can be described as one that can detect both CWAs and toxic industrial chemicals (TICs) selectively within an acceptable time; sensitive enough to detect agent concentrations at or below levels which pose a health risk, and not be affected by other factors in the environment. The detector should have a rapid reaction and recovery time whilst being portable, easy to operate and produce data that is easily interpreted. As yet, the 'ideal' detector is not a commercial reality.

Many of the commercially available CWA detectors utilise technologies that are adapted from classical analytical chemistry techniques. These technologies each have their advantages and disadvantages, which are discussed in detail in the report, and include ion mobility spectroscopy, flame photometry, infra-red spectroscopy, raman spectroscopy, surface acoustic wave, colorimetric, photo ionization and flame ionization. The commercial-off-the-shelf instruments that employ each of these technologies, are also described in the report. The content in this review is based on open-source literature and information obtained from the manufacturers.

The effectiveness of a particular detection technology can be a function of the chemical's physical properties and although the technologies have progressed significantly, there is still room for improvement. The major challenge is the need to increase detection reliability and reduce the frequency of false alarms. The future direction for detectors is to develop a capability for the detection of not only CWAs but also for a wide range of TICs. This may come from combining a number of technologies, in the form of network sensor arrays, which may offset any problems posed by individual detectors and enable a more robust response for a wider range of target chemicals. Furthermore, systems such as these may also have the potential to enable more selective, sensitive and reliable detection with fewer false alarms. Detectors with significantly improved specificity and selectivity, beyond currently available devices, will assist in providing a faster assessment of the severity and extent of a hazard and as such allow a more effective response from defence personnel and civilian first responders. However, much research is still required in this area.

Authors

Rodi Sferopoulos

Human Protection and Performance Division

Rodi Sferopoulos graduated from Victoria University in 2004 with a BSc (Hons) in Forensic Chemistry. She is currently finalising her PhD which is being conducted at Victoria University. Her PhD work explores the potential of GC/MS to identify Ignitable Liquid Residues in fire debris containing interferences from flooring and furniture materials. Rodi commenced working at DSTO in June 2006 and is part of the Chemical Sciences Capability. She contributes primarily to the Detection and Analysis Team and is currently involved in an extensive evaluation of current commercial-off-the-shelf CWA detectors.

Contents

ABBREVIATIONS AND ACRONYMS

1. INTRODUCTION.....	1
2. CHEMICAL AGENTS.....	2
2.1 Classical Chemical Warfare Agents	3
2.1.1 Nerve Agents	4
2.1.2 Vesicants (Blister Agents).....	4
2.1.2.1 Mustards	5
2.1.2.2 Arsenicals	5
2.1.2.3 Urticants.....	5
2.1.3 Blood Agents.....	5
2.1.4 Choking Agents	6
2.2 Incapacitating and Riot Control Agents	6
2.3 Toxic Industrial Chemicals	6
2.4 Chemical Agent Volatility and Toxicity	8
3. CA DETECTION	10
3.1 Detector Requirements	10
3.1.1 Detection Capability.....	11
3.1.1.1 Selectivity.....	12
3.1.1.2 Sensitivity	12
3.1.1.3 Response Time	13
3.1.1.4 False Alarms.....	13
3.1.2 Detector Performance	14
3.1.2.1 Environmental Conditions.....	14
3.1.2.2 Set up, Warm up and Recovery time.....	14
3.1.2.3 Calibration Requirements	15
3.1.2.4 Portability	15
3.1.2.5 Power Requirements.....	15
3.1.2.6 Simple User Interface.....	16
3.1.2.7 Ongoing Costs.....	16
3.1.3 Summary.....	16
4. ION MOBILITY SPECTROSCOPY (IMS)	16
4.1 IMS Technology.....	17
4.2 Advantages.....	19
4.3 Disadvantages.....	20
4.4 Existing IMS-Based Field Detectors.....	20
4.4.1 Chemical Agent Monitor (CAM).....	20
4.4.2 APD 2000	22
4.4.3 Multi-IMS/ ChemPro 100 / ChemRae.....	23

4.4.4	Raid-M and Raid-M-100	24
4.4.5	IMS 2000.....	26
4.4.6	GID-3.....	27
4.4.7	Sabre 2000 and Sabre 4000.....	28
4.4.8	LCD-3	30
4.5	Comparison of IMS Based Detectors	31
5.	FLAME PHOTOMETRY	32
5.1	Flame Photometric Detection Technology	32
5.2	Advantages.....	33
5.3	Disadvantages.....	34
5.4	Existing Flame Photometric based Field Detectors	34
5.4.1	AP2C.....	34
5.4.2	AP4C.....	36
5.4.3	MINICAMS	37
5.5	Comparison of FPD Based Detectors	38
6.	INFRA-RED (IR) SPECTROSCOPY.....	38
6.1	IR Technology	39
6.1.1	Photoacoustic IR spectroscopy	39
6.1.2	Filter IR spectroscopy	40
6.1.3	Passive infrared detection	41
6.1.4	Differential absorption light detection and ranging.....	42
6.2	Advantages.....	42
6.3	Disadvantages.....	43
6.4	Existing IR- based Detectors	43
6.4.1	M21 Remote Sensing Chemical Agent Alarm	43
6.4.2	JSLSCAD.....	44
6.4.3	MIRAN SapphIRe Portable Ambient Air Analyser.....	45
6.4.4	AN/KAS-1/1A Chemical Warfare Directional Detector	46
6.4.5	TravelIR HCI.....	47
6.4.6	HazMat ID	49
6.4.7	IlluminatIR	50
6.5	Comparison of IR Based Detectors.....	51
7.	RAMAN SPECTROSCOPY	52
7.1	Raman Spectroscopy Technology	52
7.2	Advantages.....	53
7.3	Disadvantages.....	53
7.4	Existing Raman –Based Field Detectors	54
7.4.1	FirstDefender	54
7.4.2	JCS.D.....	55
7.5	Comparison of Raman- Based Detectors	56

8.	SURFACE ACOUSTIC WAVE (SAW)	57
8.1	Surface Acoustic Wave Technology	57
8.2	Advantages	59
8.3	Disadvantages.....	59
8.4	Existing SAW- Based Field Detectors	59
8.4.1	HAZMATCAD	59
8.4.2	JCAD and JCAD ChemSentry 150C.....	61
8.4.3	CW Sentry Plus	62
8.4.4	SAW MINICAD mk II	62
8.5	Comparison of SAW- Based Detectors	64
9.	COLORIMETRIC	65
9.1	Colorimetric Technology	65
9.2	Advantages	65
9.3	Disadvantages.....	65
9.4	Existing Colorimetric Field Detectors	66
9.4.1	Chemical Detector Paper	66
9.4.1.1	M8 Detection Paper	66
9.4.1.2	M9 Detection Paper	67
9.4.1.3	3-Way Chemical Agent Liquid Detection Paper.....	68
9.4.2	Colorimetric Detection Tubes	68
9.4.2.1	Simultaneous Test Sets	69
9.4.3	Detection Kits.....	71
9.4.3.1	M-256A1 CA Detection Kit	71
9.4.3.2	The M18A3 CA Detector Kit	72
9.4.3.3	Chemical Agent Water Testing Kit M272	73
9.5	Comparison of Colorimetric Based Detectors	74
10.	PHOTO IONISATION DETECTION (PID)	75
10.1	PID Technology.....	75
10.2	Advantages	76
10.3	Disadvantages.....	76
10.4	Existing PID Field Detectors.....	77
10.4.1	RAE Systems	77
10.4.1.1	MiniRAE 2000	78
10.4.1.2	MiniRAE 3000	78
10.4.1.3	ppbRAE.....	79
10.4.1.4	ppbRAE 3000.....	81
10.4.1.5	ppbRAE Plus	82
10.4.1.6	MultiRAE Plus	82
10.4.1.7	ToxiRAE Plus PID	84
10.4.2	TVA1000B Toxic Vapour Analyser	84
10.5	Comparison of PID- Based Detectors	85

11. FLAME IONISATION DETECTION (FID)	86
11.1 FID Technology	86
11.2 Advantages	87
11.3 Disadvantages	87
11.4 Existing FID Field Detectors	87
11.4.1 Photovac MicroFID Handheld Flame Ionisation Detector	87
12. NETWORK SENSOR ARRAYS	88
13. CONCLUSION	89
14. REFERENCES	90

Abbreviations and Acronyms

AC	Hydrogen Cyanide
ACADA	Automatic Chemical Agent Detector and Alarm
AEL	Acceptable exposure limit
APCI	Atmospheric Pressure Chemical Ionisation
APD 2000	Advanced Portable chemical agent Detector
ATR	Attenuated total reflection
CA	Chemical Agent
CAM	Chemical Agent Monitor
CAs	Chemical Agents
CDS	Civil Defence Simultest
CG	Phosgene
CK	Cyanogen Chloride
CWAs	Chemical Warfare Agents
CWDD	Chemical Warfare Directional Detector
CX	Phosgene oxime
dB	Decibel
DP	Diphosgene
ECAM	Enhanced Chemical Agent Detector
ECBC	Edgewood Chemical Biological Center
FID	Flame Ionisation Detection
FIDs	Flame Ionisation Detectors
FLIR	Forward Looking Infrared Spectroscopy
FPD	Flame Photometric detection
FPDs	Flame Photometric detectors
FTIR	Fourier Transform Infrared Spectroscopy
GA	Tabun
GB	Sarin
GC	Gas Chromatograph
GD	Soman
GF	Cyclosarin
HAZMAT	Hazardous Materials
HD	Sulfur Mustard
HL	Mustard Lewisite
HN-1, HN-2, HN-3	Nitrogen Mustards
HPO*	excited phosphorus
ICAM	Improved Chemical Agent Detector
IC_{t50}	Incapacitating concentration and time of a toxic substance required to kill 50% of an exposed population
IDLH	Immediate Danger to Life and Health
IDTs	Interdigital Transducers
IMS	Ion Mobility Spectrometry
IPE	Individual protective equipment

IR	Infrared
JCAD	Joint Chemical Agent Detector
JCS	Joint Contaminated Surface Detector
JSLSCAD	Joint Service Lightweight Standoff Chemical Agent Detector
L	Lewisite
LCD	Lightweight Chemical Detector
LCD	Liquid Crystal Display
LCt₅₀	Lethal concentration and time of a toxic substance required to kill 50% of an exposed population
LD₅₀	Median lethal dose of a toxic substance required to kill 50% of an exposed population
LED	Light emitting diode
LOD	Limit of Detection
MDL	Minimum Detectable Level
mg/m³	Milligram per cubic metre
NATO	North Atlantic Treaty Organisation
OPCW	Organisation for the Prohibition of Chemical Weapons
PD	Phenyldichloroarsine
PEL	Permissible exposure limit
PID	Photo Ionisation Detection
PIDs	Photo Ionisation Detectors
ppb	Parts per billion
ppm	Parts per million
RAID-M	Rapid Alarm and Identification Device - Monitor
REL	Recommended exposure limit
RSCAAL	M21 Remote Sensing Chemical Agent Alarm
S₂*	excited sulfur
SA	Arsine
SAW	Surface Acoustic Wave
STEL	Short term exposure limit
TICs	Toxic Industrial Chemicals
TIMs	Toxic Industrial Materials
TWA	Time weighted average
UV	Ultraviolet
VOCs	Volatile Organic Compounds
VX	O-ethyl-S-diisopropyl amino methyl phosphonothiolate
WMD	Weapons of Mass Destruction
XSD	Halogen Specific detector
µm	microns

1. Introduction

This report describes the technologies used in commercially available detection and sensor equipment currently employed for detecting chemical warfare agents (CWAs) and toxic industrial chemicals (TICs). A brief description of some of the well known, commercial-off-the-shelf detectors that employ these technologies is included. The content in this review is obtained from the open-source literature and information obtained by manufacturers of these detectors.

Weapons of mass destruction (WMD) are weapons which are capable of producing large scale destruction and/or of being used to kill or seriously injure a large number of people¹. They include chemical weapons, which are defined by the Organisation for the Prohibition of Chemical Weapons (OPCW) as “... *anything specifically designed or intended for use in direct connection with the release of a chemical agent (CA) to cause death or harm*”². This definition can be further divided into three parts to include toxic chemicals and their precursors, munitions or devices, and equipment.

Toxic chemicals are defined as any chemical which can cause death, temporary incapacitation, or permanent harm to humans or animals, through its chemical action on life processes, whilst precursors are the chemicals involved in the production of toxic chemicals². Munitions or devices include such things as mortars, artillery shells, missiles, bombs, mines or spray tanks. Hence they are specifically designed to inflict harm or cause death through the release of toxic chemicals. Finally, equipment, as defined by the OPCW, refers to any equipment specifically designed for use “... *directly in connection*” with the employment of the munitions and devices².

Thus, CA is the term used to signify the toxic component of a chemical weapon and can include CWAs and/or TICs. These agents are incorporated in WMD to cause mass casualties by killing, seriously injuring or incapacitating a targeted population through their physiological effects¹⁻⁵.

It is well known that chemical agents (CAs) have been used against military personnel during conventional warfare, however, due to the increasing threat of terrorist activities, the focus has now broadened to encompass the threat posed to civilians^{1, 3}. As a result, the perceived threat of a CA attack has the potential to create great panic in parties that are unprepared because when released, these agents are amorphous and not able to be evaded¹. Hence, if there is no capability available to detect and monitor these agents it is safe to assume that there is no preparation for a potential attack, and therefore the first signs of exposure to an agent will be when symptoms begin to appear, which may be too late⁶.

In a military setting, the threat of CAs can radically affect land and sea operations as well as the use of air assets⁶. Furthermore, many defence operations are controlled from fixed bases, which contain complex equipment required for operations thus making them an ideal target for a chemical weapons attack. In the event of a CA release, any agent will need to be quickly detected and identified to allow such facilities to operate at their optimum level. Rapid detection will inform commanders in a timely manner allowing them to instruct troops to don

protective equipment and plan appropriate courses of action, such as altering their route and/or warning adjacent units⁶⁻⁸. The spread of agent must also be able to be monitored effectively and efficiently, so that areas, both contaminated and clean, can be identified. This knowledge will allow for an effective response in the event of exposure⁹. Consequently, if the military are well prepared for a potential attack, in that they have the ability to detect and therefore protect themselves, the likelihood of their operations being adversely affected will be significantly reduced.

Furthermore, the ability to rapidly detect, identify and monitor CAs in the event of an attack is also vital for the efficient use of civil defence resources. This capability has the potential to reduce panic and chaos and minimise potential casualties⁶⁻⁸.

The above contextual factors illustrate that systems offering detection capabilities need to be reliable, sensitive, accurate and easy to use so as to enhance an armed forces' and/or civilian agencies' ability to rapidly deal with attacks and minimise the fatal effects of agents^{6, 10}.

With the ever increasing perceived threat of terrorist CA attacks¹⁰, it is unlikely that investment in detection technology will decrease anytime soon and science and engineering will be integral in reducing the threat against chemical warfare⁹.

2. Chemical Agents

Whilst CAs can cause serious injury or death, it is the method and accuracy of their delivery that determines the severity of the damage¹. CAs can be delivered in artillery shells or missiles, by aerial bombing or spraying and can be dispersed in a variety of different forms, including solid, liquid, gas, vapour and aerosol. Thus a CAs route of entry into the body is dependent on which form it is in. A gas, vapour or aerosol can be inhaled and can also enter the body via the eyes, whereas entry via the skin usually occurs when the agent is in liquid form. A vapour can also be absorbed through the skin, however for this to happen, exposure must occur over a long period of time^{5, 11}. As illustrated CAs can enter the body through a number of pathways where they immediately interact with the normal chemistry of the body, for example nerve agents attack the central and peripheral nervous system and prevents them from functioning normally^{1, 3, 4}. Hence, exposure to a CA is usually disabling and in some instances, fatal³.

The ultimate effectiveness of chemical weapons is thus determined by the agent delivery, volatility, area of dispersal (downwind), doses inhaled or absorbed and actual dose disseminated, symptoms and performance degradation¹. Volatility refers to an agent's ability to become a vapour at relatively low temperatures, therefore a highly volatile (non-persistent) CA will pose a greater respiratory hazard than a less volatile (persistent) agent, however as the name implies, an agent that persists in the environment will remain a contact hazard for a longer period of time³.

CAs are classified according to their mode of action, lethality or by their persistence (the time they remain active in the environment)^{5, 9}. Potential agents range from the classical CWAs, to

TICs which are commonly used in manufacturing industry^{1, 4, 12}. Hence, when referred to in this report, CAs refers to both the classical CWAs and TICs.

2.1 Classical Chemical Warfare Agents

Classical CWAs are listed in Table 1 and include nerve, blister, blood and choking agents. Incapacitating and riot control agents can also be included in this category. These agents are aptly named based on their mode of action (i.e. route of penetration and their effect on the body) and sometimes according to their intended use^{4, 12}.

Table 1: List of Classical CWAs²

Classical CWAs		
Agent Class	Agent Name	Abbreviation
Nerve	Tabun	GA
	Sarin	GB
	Soman	GD
	Ethyl Sarin	GE
	Cyclosarin	GF
	O-ethyl- S-diisopropyl amino methyl methylphosphonothiolate	VX
	S-(Diethyl amino)ethyl O-ethyl ethylphosphonothioate	VE
	Amiton or Tetram	VG
	Phosphonothioic acid, methyl-, S-(2-(diethyl amino)ethyl) O-ethyl ester	VM
Vesicants	Sulfur Mustard	H, HD
	Nitrogen Mustard	HN-1, HN-2, HN-3
	Lewisite	L
	Mustard-lewisite	HL
	Phenyldichloroarsine	PD
	Phosgene Oxime	CX
Blood	Hydrogen Cyanide	AC
	Cyanogen Chloride	CK
	Arsine	SA
Choking	Chlorine	Cl
	Phosgene	CG
	Diphosgene	DP
	Chloropicrin	PS

2.1.1 Nerve Agents

Nerve agents are a group of particularly toxic CWAs that belong to the chemical group of organophosphorus compounds. They are generally stable, easily dispersed and highly toxic^{3, 13}.

Nerve agents fall into two categories, the 'G' and the 'V' agents. The 'G' nerve agents are so named as they were first synthesised by German chemists in the late 1930s². They include Tabun (GA), Sarin (GB), Soman (GD) and Cyclosarin (GF), which are fluorine (GB, GD, GF) or cyanide (GA) containing organophosphorus compounds². The 'V' agents, which are sulfur-containing organophosphorus compounds, were developed in the 1950s by British chemists and are more toxic and persistent than the 'G' agents^{1-3, 12, 14}. The most common of these agents is VX^{1-3, 12, 14}. In general, the persistency of nerve agents ranges from low for GB through to very high for VX².

Nerve agents can be disseminated as vapours, aerosols, or liquids and enter the body via inhalation or through the skin. When absorbed in the body, they inhibit the proper functioning of the cholinesterase enzymes, resulting in rapid disruption of the normal transmission of nerve impulses in the body^{1, 12, 13}. An exposed person will develop signs and symptoms within seconds following exposure, and when a sufficient dose enters the body death may occur within minutes^{3, 12, 15}.

The symptoms of nerve agent exposure may be influenced by the route of entry in the body, however the most characteristic symptoms include difficulties in breathing, tightness of the chest, constriction of the pupils, muscular twitching, drooling, excessive sweating, nausea, vomiting, and abdominal cramps^{3, 12, 13}. Due to the rapid action and high lethality of these agents, there are urgent demands for rapid and reliable methods for early detection and identification of nerve agents [and their degradation products]¹⁶.

2.1.2 Vesicants (Blister Agents)

Vesicants, also known as blister agents, are primarily intended to injure rather than kill people, however, exposure in some cases can be fatal^{3, 12, 13}. The three types of blister agents, mustards, arsenicals and urticants¹, are relatively persistent and may be used in the form of colourless vapours and liquids³.

Vesicants are readily absorbed by all parts of the body, including the eyes, mucous membranes, lungs, skin and blood-forming organs^{3, 12, 13}. They cause inflammation, blisters and general destruction of tissue. Furthermore, the severity of blister burns is directly related to the concentration of the agent and the duration of contact with the skin^{1, 3}. However the actions of some vesicants can be delayed anywhere between two and 24 hours before any pain or symptoms are produced by which time cell damage has already occurred³. Furthermore, in order to contaminate terrain, ships, aircrafts, vehicles or equipment with a persistent hazard, vesicants can be thickened^{1, 13}.

2.1.2.1 *Mustards*

Mustards include the agents sulfur mustard (HD) and the three nitrogen mustards (HN-1, HN-2 and HN-3)^{12, 13}, which are stable liquids with low volatility at room temperature. However they are usually disseminated as a vapour or a liquid^{1, 3}. They have a characteristic smell (although the sense of smell is dulled after only a few breaths) and are capable of causing injury to the respiratory system in concentrations that are so low that the human sense of smell cannot detect them^{1, 3}.

Mustards attack the skin, eyes, lungs and gastrointestinal tract and when absorbed through the skin or lungs, they are transported into the body where they can damage internal organs¹. Moist skin absorbs mustard more readily than dry skin, so in hot and humid weather a higher casualty rate will result¹².

Symptoms of mustard exposure are influenced by the route of entry into the body. Entry by way of skin contact results in redness, itching and formation of blisters, whilst exposure to the eyes causes irritation, pain swelling and tearing. Inhalation of mustard results in symptoms which include a runny nose, sneezing, hoarseness, bloody nose, sinus pain, shortness of breath and coughing¹⁷.

2.1.2.2 *Arsenicals*

Arsenicals, including lewisite (L), mustard-lewisite (HL) and phenyldichloroarsine (PD), have arsenic as a central atom in their chemical structure, and are more dangerous as liquids than vapours due to their lower volatility^{1, 3}. Although not as common or stable as mustards, arsenicals produce much the same injuries to the skin and mucous membranes but also have the added effect of being systemic poisons¹.

2.1.2.3 *Urticants*

Urticants are blister agents that cause an immediate, severe burning sensation followed by intense pain and then a feeling of numbness¹. Upon contact with skin, phosgene oxime (CX), the most common urticant, produces immediate pain which resembles a bee sting. The pain is the result of a violent and rapid reaction of CX with the skin which consequently results in CX being quite difficult to decontaminate effectively. The best way of removing excess agent on the skin is by flushing with large amounts of water immediately upon exposure¹².

2.1.3 Blood Agents

Blood Agents, including hydrogen cyanide (AC), cyanogen chloride (CK) and arsine (SA), are highly volatile and thus able to enter the body through the respiratory tract^{1, 12}. They interfere with oxygen metabolism in cells by preventing the normal utilisation of oxygen leading to respiratory failure^{11, 12}. AC, for example, acts by inhibiting the cytochrome oxidase enzyme reaction, which is responsible for directing oxygen utilisation in the bloodstream. As a result of exposure, breathing rate is increased which leads to the inhalation of a larger dose¹².

Symptoms of blood agent exposure are related to dose. Low-dose exposure causes headache and uneasiness, higher-dose exposure causes chills, nausea, and vomiting and severe exposure damages blood cells, leading to anaemia and eventual death¹².

2.1.4 Choking Agents

Choking Agents, such as phosgene (CG) and diposgene (DP), are lethal CWAs which target the respiratory tract and lungs and are designed to cause death to an exposed individual^{1, 12}.

Upon inhalation, these agents cause the respiratory tract to become irritated and the membranes to swell. This swelling triggers the secretion of copious amounts of fluid, which causes excessive coughing as the body tries to clear the airway. Despite the coughing, the lungs may fill with fluid causing the victim to 'choke', whilst literally drowning in their own body fluid. The effects of choking agents may be immediate or delayed depending upon exposure concentrations. Furthermore, when the dosage is high enough, death will occur¹².

2.2 Incapacitating and Riot Control Agents

Incapacitating or riot control agents are defined as being "*... any chemical not listed in a Chemical Weapons Convention schedule which can rapidly produce, in humans, sensory irritation or disabling physical effects which disappear within a short time following termination of exposure*"². These agents do not seriously endanger lives unless very high doses are received. As the name implies, they are designed to incapacitate individuals making them physically less effective. These agents are also designed to produce physiologic or mental effects that may persist for several hours or days after exposure¹².

The incapacitating agents that cause vomiting are normally solids that are vaporised and condensed to form aerosols. The tear-producing compounds which are widely used for training and riot control cause copious tears and irritation of the skin¹². Riot control agents are chemicals which produce transient effects that disappear within minutes after exposure and very rarely require medical treatment. These agents are effective in suppressing civil disturbances, and in some military operations, preventing unnecessary loss of life.

2.3 Toxic Industrial Chemicals

TICs are another class of CAs that are less deadly than conventional CWAs but pose a greater threat because they are more easily accessible in large quantities and are widely used in the manufacturing or primary material processing (mining and refining) industries^{1, 3, 12}. Whilst exposure to CWAs usually results in fatalities, exposure to TICs may not be life threatening, however multiple low level exposures can be extremely serious, causing ongoing effects on an individual's health³.

TICs are ranked as being a high, medium or low hazard, depending on their toxicity level, amount being produced and relative volatility¹². A comprehensive list of TICs and their hazard levels is shown in Table 2. High-hazard TICs are widely produced, stored and/or transported, have high toxicities and are easily vaporised. This group contains mainly inorganic chemicals excluding formaldehyde and ethylene oxide. Medium-hazard TICs are

highly toxic, produced in large quantities and vaporise easily, whilst low-hazard TICs include compounds that have relatively low toxicity, vapour pressure or volatility, and are produced, stored, or transported in relatively small quantities¹².

Table 2: TICs and their hazard levels¹⁸

High	Medium	Low
Ammonia	Acetone cyanohydrin	Allyl isothiocyanate
Arsine	Acrolein	Arsenic trichloride
Boron trichloride	Acrylonitrile	Bromine
Boron trifluoride	Allyl alcohol	Bromine chloride
Carbon disulfide	Allylamine	Bromine pentafluoride
Chlorine	Allyl chlorocarbonate	Bromine trifluoride
Diborane	Boron tribromide	Carbonyl fluoride
Ethylene oxide	Carbon monoxide	Chlorine pentafluoride
Fluorine	Carbonyl sulfide	Chlorine trifluoride
Formaldehyde	Chloroacetone	Chloroacetaldehyde
Hydrogen bromide	Chloroacetonitrile	Chloroacetyl chloride
Hydrogen chloride	Chlorosulfonic acid	Crotonaldehyde
Hydrogen cyanide	Diketene	Cyanogen chloride
Hydrogen fluoride	1,2-Dimethylhydrazine	Dimethyl sulfate
Hydrogen sulfide	Ethylene dibromide	Diphenylmethane-4,4'-diisocyanate
Nitric acid, fuming	Hydrogen selenide	Ethyl chloroformate
Phosgene	Methanesulfonyl chloride	Ethyl chlorothioformate
Phosphorus trichloride	Methyl bromide	Ethyl phosphonothioic dichloride
Sulfur dioxide	Methyl chloroformate	Ethyl phosphonic dichloride
Sulfuric acid	Methyl chlorosilane	Ethyleneimine
Tungsten hexafluoride	Methyl hydrazine	Hexachlorocyclopentadiene
	Methyl isocyanate	Hydrogen iodide
	Methyl mercaptan	Iron pentacarbonyl
	Nitrogen dioxide	Isobutyl chloroformate
	Phosphine	Isopropyl chloroformate
	Phosphorus oxychloride	Isopropyl isocyanate
	Phosphorus pentafluoride	n-Butyl chloroformate
	Selenium hexafluoride	n-Butyl isocyanate
	Silicon tetrafluoride	Nitric oxide
	Stibine	n-Propyl chloroformate
	Sulfur trioxide	Parathion
	Sulfuryl chloride	Perchloromethyl mercaptan
	Sulfuryl fluoride	sec-Butyl chloroformate
	Tellurium hexafluoride	tert-Butyl isocyanate
	n-Octyl mercaptan	Tetraethyl lead
	Titanium tetrachloride	Tetraethyl pyrophosphate
	Trichloroacetyl chloride	Tetramethyl lead
	Trifluoroacetyl chloride	Toluene 2,4-diisocyanate
		Toluene 2,6-diisocyanate

2.4 Chemical Agent Volatility and Toxicity

The effectiveness of a deployed CA is generally dictated by its volatility and toxicity. Volatility is a measure of a substance's ability to become a vapour at relatively low temperatures¹². Toxicity is a measure of the degree to which a substance is toxic or poisonous and is usually measured by the effects on a target or a targeted population. Therefore, when dealing with CA detector effectiveness for deployment, the volatility and toxicity of an agent needs to be carefully considered¹². Furthermore, the way in which an agent behaves and subsequently the requirements of a detector are directly influenced by the physical and chemical properties of the agent¹². For example, volatile or non-persistent CAs have a higher respiratory toxicity than those that are less volatile, and therefore detectors with very low detection limits will be required^{3, 12}. As a result the detection of each agent will be dictated by the properties and specific hazards associated with it¹².

The toxicity of chemicals can be expressed in terms of immediate danger to life and health (IDLH) level, lethal dose (LD₅₀), lethal concentration/ time (LCt₅₀), incapacitating concentration (ICt₅₀), REL (recommended exposure limit), PEL (permissible exposure limit) and AEL (acceptable exposure limit)¹². The volatilities and toxicities of some CAs are given in Table 3.

Table 3: Table showing volatilities and toxicities of CAs¹²

Agent Class	Agent	Volatility (mg/m ³ at 20°C)	IDLH (ppm)	LCt ₅₀ (mg-min/m ³)	ICt ₅₀ (mg-min/m ³)*
Nerve	GA	328	0.03	400*	300
	GB	1.61 × 10 ⁴	0.03	100*	75
	GD	3.900 (25°C)	0.008	70*	In GA and GB range
	GF	438	0.03	-	-
	VX	10.5 (25°C)	0.002	100*	50
Blister	HD	610	0.0004 ¹	1500	150
	HN-1	1520		1500	-
	HN-2	3580(25°C)		3000	-
	HN-3	121 (25°C)		1500	-
	L	4480	0.0003 ²	1400	-
Blood	AC	1.08 × 10 ⁶ (25°C)		2000 to 4500	Varies with concentration
	CK	Gas		11000	7000
	SA	3.09 × 10 ⁷ (0°C)		5000	2500
	CG	4.3 × 10 ⁶ (7.6°C)		3200	1600
	DP	4.5 × 10 ⁴		3000	1600

*For respiratory exposure

¹The value used for HD is the 8 hr Time Weighted Average (TWA) since no IDLH value has been identified¹⁹

²The value used for L is the 8 hr TWA since no IDLH value has been identified¹⁹

IDLH is the agent concentration in the air that would cause immediate or delayed permanent adverse health effects after 30 minutes of unprotected exposure¹². Thus, it is the concentration of agent below which a person will have sufficient time to either escape safely or seek protection without incurring serious injury or irreversible health effects. A lower IDLH value means that the compound is more dangerous and as such has greater toxicological effects¹².

However, exposure to chemicals at concentrations much lower than the IDLH level for long periods of time can also be dangerous or even fatal¹².

Due to the toxicity of an agent being partially dependent on the route of exposure, it is generally measured in terms of dose or exposure level, and due to individuals having different levels of response to the same dose of a toxic compound, a population level measure of toxicity is often used²⁰. One such measure is Time Weighted Average (TWA), which reflects the exposure level of an agent over a period of time¹².

In general, CAs have volatilities which are higher than their respective IDLH concentrations which means that CAs can easily reach dangerous vapour concentrations in the air¹². Furthermore, because volatility is directly related to temperature, at higher temperatures, agents will have relatively higher volatilities¹².

The LD₅₀ is the dose of a liquid or solid CA that kills half the members of an exposed population. LC_{t50} is a vapour concentration measure over time, where half of those exposed to agent die²⁰. LC_{t50} is a function of vapour concentration (mg/m³) and exposure duration, in minutes, where values are established for both inhalation and percutaneous exposures. Inhalation dosages are much lower than those received by percutaneous exposure because the body absorbs the chemical vapour much faster and more effectively through the respiratory tract than through the skin¹². Compounds with LD₅₀ or LC_{t50} values of 50-500 mg/kg, 50-500 mg/m³ and 200-500 mg/kg for oral, inhalation and dermal routes respectively, are considered moderately toxic, whilst compounds with higher values are considered to have low toxicity²⁰.

IC_{t50} is the concentration of an agent multiplied by the exposure time that incapacitates half of an exposed population¹¹. The IC_{t50} value is lower than the LC_{t50} because it is the dosage that will cause performance degradation rather than death¹².

Other toxicity measures include REL which is the maximum TWA concentration for up to a 10 hour workday during a 40 hour work week¹². PEL is the TWA concentration that must not be exceeded during any 8 hour workday of a 40 hour work week and STEL, or short term exposure limit, is designed for a 15 minute TWA exposure that should not be exceeded at any time during a workday¹².

Although TICs are not as lethal as the highly toxic nerve agents, they can still have a significant impact on a targeted population. However this is assumed to be more related to the amount of a chemical which can be employed and less related to its lethality¹⁸. Therefore larger doses of TICs may kill or harm more people than CWAs.

3. CA Detection

All of the CWAs currently considered to be a threat have been known for decades, with the simplest and most prolific CWA being the vesicant, sulfur mustard which was first synthesised in 1823^{1, 21}. As a result, the patterns of defence have also been fairly conservative, with detector technology being somewhat reactive rather than proactive²¹. Most detectors are designed to respond only when a threat is directly imminent and therefore tend to 'detect to respond' or 'detect to react' rather than 'detect to warn'²².

The term 'CA detection' can be defined as the systems and methods utilised for detecting and monitoring CAs and providing early warning of an imminent danger^{9, 22}. In the event of an attack by CAs, this capability is essential to enable the potential number of casualties to be reduced, or perhaps eliminated¹². With respect to the military, early warning of an attack can provide commanders with enough time to plan appropriate courses of action and warn adjacent units^{6-8, 12}. Early warning will also give troops time to don individual protective equipment (IPE), with the basic items being the respirator (gas mask) and protective suit, both of which were originally developed at the end of World War I²¹.

IPE is still utilised as the main form of protection against a chemical weapons attack as it has been proven to provide effective protection for an individual whilst the agent is neutralised or eliminated. Whilst IPE does provide adequate protection for the individual it also reduces the effectiveness of the wearer. Therefore, it is critical to monitor the level of hazard in the environment so that the IPE can be removed once it is safe to do so thereby reducing the physiological stress imposed through the wearing of full protective clothing^{4, 21}. Hence detection equipment is not only crucial for the effective early warning of a potential CA attack but also for the continual monitoring of the environment to allow an individual to assess when it is safe to remove their IPE¹².

Many of the current CA detectors have technologies that are adapted from classical analytical chemistry techniques and although these technologies have progressed significantly, progress is still lacking in some areas^{9, 14, 22}. For example, detection technologies have not yet been developed to permit detection of lowest level concentrations under the AEL criteria¹².

The focus of most international research and development activities is now in the area of agent detection and identification and in the field of response via command and control systems²¹. However, there is a need to improve and expand the use of sensors in countering terrorism and minimising the impact on a civilian population should an incident occur. Beyond point sampling devices, it is of the utmost importance to develop sensors which will help provide sensitive and rapid detection and advanced warning of toxic vapours at fixed sites such as buildings, train stations and airports or air bases¹¹.

3.1 Detector Requirements

Until recently CA detection and IPE have primarily been the concerns of soldiers who face the threat of chemical attacks on the battlefield. However, with the increasing threat of terrorism, the roles of CA detectors are also increasing in civil emergency responses. In these instances,

the detectors are used to monitor the presence of CA in the atmosphere, provide an indication of their levels in order to determine the necessary level of protection, locate or define the limits of contamination and/or monitor the effectiveness of decontamination²³.

CA detectors are required to function in demanding, real-world environments where cost, portability and time are important factors. They must also be operational around the clock, widely deployable and able to be networked¹². Another imperative factor is that detectors are able to detect CAs with specificity and not be affected by coexisting substances in the atmosphere or by humidity or temperature¹². At present, the most challenging aspect for detection and identification of CAs is the differentiation of the agent of interest from other chemicals already present in the environment²². Furthermore, detection sensitivity is a necessary factor as detectors are required to provide advanced warning, and be able to detect concentrations of CAs well below the IDLH levels¹².

Ideally when selecting a detector, consideration must be given to a number of factors relating to detection capability and detection performance. Detection capability involves factors such as selectivity, sensitivity, response time and false alarm rates whilst detector performance includes factors such as warm-up time, calibration requirements, portability, power requirements and ongoing costs associated with training and maintenance¹².

A desirable detector would be one that can detect both CWAs and TICs selectively within an acceptable time, thus enabling an effective medical response. It must be sensitive enough to detect agent concentrations at or below levels which pose a health risk, and should not be affected by other factors in the environment which cause false alarms^{12, 24}. The detector should also have a rapid reaction and recovery time, that is, it should alarm for high concentrations of agent within seconds and rapidly recover²⁵. Furthermore it should be portable, easy to operate and any data should be easily interpreted. As yet, no 'ideal' detector, which meets all the abovementioned requirements, is commercially available.

3.1.1 Detection Capability

The ability to detect the presence of CAs is important due, in large part, to the ability of the CA to cause immediate damage and the fact that there may be no effective therapy available^{12, 24}.

At present there is a wide variety of detectors commercially available, however, due to their individual capabilities, not all are suitable for use in every potential threat situation. Therefore when choosing a detector a number of factors must be taken into consideration, including selectivity, sensitivity, response time, false alarm rates and simple user interface¹².

The ability of a detector to detect target CAs within an acceptable time and concentration limit is imperative to protect the users. Therefore detectors and monitors of varying sensitivity (lowest level detectable) and selectivity (ability to distinguish target from similar compounds) have been developed and/or used by the armed forces, emergency services and hazard management (HAZMAT) responders to identify CAs^{12, 15}.

The alarm threshold of detectors must be able to provide sufficient time for responders to don protective gear before they become casualties. Also important is the detectors' ability to resist false alarms¹². Many currently fielded CA detection systems suffer from excessive false alarms when exposed to common substances, resulting in their usefulness being greatly diminished¹⁵. Equally, if not more importantly, is the ability of a device to function properly when in the presence of interferent vapours.

3.1.1.1 Selectivity

Selectivity is the ability of a detector to respond only to the targeted chemicals in a sample. A selective detector must be able to separate targeted compounds, over a broad range of concentrations, from any other substances which may be present in a sample¹².

Many CA detectors are specific to certain agents, or need to be configured ahead of time to look for a particular agent. Hence, depending upon the technology employed, detectors vary in selectivity for certain compounds²³. However, the major disadvantage associated with selective detectors is that they are limited in the number of compounds that they can detect. Presently there is no single detector that is absolutely selective or non-selective¹². For example, a CWA detector based on Flame Photometric Detection (FPD) will only respond to phosphorus and sulfur compounds. Therefore in the event that a CA containing no phosphorus or sulfur is released it will not be detected by an FPD-based detector¹².

A selective CA detector may, however, respond to chemicals that possess similar properties to CAs, thus producing a false positive response. A less selective detector, on the other hand, will respond to a larger number of chemicals without discrimination and its responses cannot immediately be attributed to CAs or non-toxic substances¹².

For field applications, non-selective detectors may be more suitable if a broad spectrum early warning system is desired or if the environment is clean, that is, it has not been exposed to any CAs¹². Non-selective detectors may be utilised to provide an initial survey of an area in a civilian scenario, given that these detectors can respond to various chemicals simultaneously and that chemicals used by terrorists are generally unpredictable¹². However, if a non-selective detector produces a response, it would be necessary to survey the suspect area with a more specific detector to identify or discriminate potential CAs from other compounds present¹².

3.1.1.2 Sensitivity

Sensitivity is determined by the lowest concentration of a CA that can be detected with confidence¹². It can also be referred to as the limit of detection (LOD) or detection limit. Sensitivity may also be a measure of a detector's ability to discriminate between small differences in the concentration of an analyte. Hence, a sensitive detector gives a large change in signal intensity for a small change in concentration¹². In general, the more toxic a chemical is the more sensitive the detector needs to be.

The sensitivity of a detector may be dependent upon a number of factors including the CA and environmental and operational conditions³. A suitable detector should have a low limit of

detection and subsequently provide a warning well before the IDLH level is reached to permit proper evacuation of personnel¹². However, the concentrations of classical CWAs do not vary greatly between their IDLH and LD₅₀ levels, thus it is imperative that any detector utilised is sensitive enough to measure CA concentrations in small quantities or, as a minimum, at non-hazardous levels. This is largely due to the fact that minute quantities of a CA could seriously impact human health^{9, 25}.

At present, the sensitivity and specificity of many of the existing detectors needs to be improved significantly¹².

3.1.1.3 *Response Time*

Response time is the time it takes for a detector to collect and analyse a sample, determine if an agent is present, and provide feedback. In other words, it is the time required for the detector to respond to targeted chemicals^{3, 12}. A desirable response time for a detector is in the order of one minute or less, however due to the rapid action of many of the CAs, it is extremely important that a detector be able to respond in as near real time as possible, to minimise exposure and guide medical intervention^{9, 24}.

An important aspect, with respect to response time, is the elapsed time for an alarm to occur after the detector is exposed to a targeted chemical at different concentration levels¹². Currently there is no detector that will respond quickly enough to prevent CA exposure to some individuals. Subsequently the available technology may be more suited to incident monitoring or presumptive CA identification rather than for the detection and early warning of the presence of CAs⁹.

3.1.1.4 *False Alarms*

False alarms occur if a detector responds when a CA is not present, false positive, or it fails to respond to a CA that is present, false negative^{3, 9, 18}. In general, the alarm levels for a detector are deliberately set low to ensure a minimal number of false negatives, however this means that false positives are more likely²⁶.

False positive alarms are usually observed when the targeted compound is in the presence of an interferent, which may be a chemical molecularly similar to a CA, or a substance which may contain elements that are also present in CAs²³. For example, pesticides containing sulfur or phosphorus would generate a false positive CA alarm when an FPD-based detector is used¹².

The occurrence of false positives in a civilian setting may have serious implications as it could lead to extreme disruption and possibly panic. More importantly however, repeat false positive alarms could lead to future 'real' alarms being ignored⁹. At present detectors are prone to give false positive alarms as most detect multiple compounds with none being completely selective for a specific CA or class of agents. To overcome this problem another detector, based on a different technology, can be used to confirm any alarm^{9, 12}.

False negative alarms are more problematic than false positive alarms because the failure to produce an alarm may lead to dangerous situations. The failure of a detector to alarm to a CA that is present may be due to any number of reasons including operator error, changing environmental conditions, humidity effects, detector malfunction such as software quirks, and the presence of chemical interferents which may mask normal detection capabilities¹².

Ideally, false alarm rates should be zero but in practice this is rarely so⁹. It is therefore imperative that the likely incidence of false responses and the detectors' ability to resist interferents be thoroughly explored prior to its deployment^{3, 9, 18}.

3.1.2 Detector Performance

One of the most important parameters when considering a detector's performance is its ability to operate under a variety of environmental conditions¹². Ideally, a detector should be able to maintain its designated functions regardless of the environmental conditions in which it is deployed¹².

At present commercially available detectors vary in a number of areas including warm-up time, calibration requirements, portability, power requirements and ongoing costs associated with training and maintenance. As a result, choosing the correct detector for an operation can prove to be quite challenging. In general, a detector must be easy to operate, achieve operational stability within a short period of time and require minimal recalibration after a period of storage. Other concerns include the costs associated with operation, the time required to clear any residual chemical from the previous sample, waste generation, storage effects, maintenance frequency, ease of decontamination, if data can be saved for later analysis and whether the detector can be networked to other systems or be remotely controlled¹².

Furthermore, a detector that is capable of detecting nerve agents may not be very useful for detecting certain TICs. Therefore to choose a suitable detector, knowing the target chemicals is also a very important factor to take into consideration, as this will help determine which techniques are best suited for the application¹².

3.1.2.1 *Environmental Conditions*

Environmental conditions, such as temperature, humidity, wind, dust and contamination concentration in the air, can affect the performance of a detector¹². At present all the existing commercially available detectors are affected to one degree or another by environmental conditions, therefore it is crucial that during the selection process it is determined if a detector is able to operate effectively in the intended environment ¹².

Generally the operational temperature and humidity ranges are provided by the manufacturers¹².

3.1.2.2 *Set up, Warm up and Recovery time*

Set up time is defined as the time needed to power up a detector. Handheld detectors usually have a minimal set up time as they are self-contained with only batteries as separate parts¹².

Warm up time, on the other hand, is the time required for a detector to become ready for analysis after it has been turned on¹². During the warm up period most detectors will go through a series of internal self checks to satisfy preset parameter requirements before they are ready for analysis¹². However, depending upon the detector this warm up time could range from a few seconds to half an hour or longer¹². It is thus desirable that a detector be turned on and ready to operate within a short time. This is especially important for first responders in an emergency situation¹².

The recovery time is the time taken for a detector display to return to the baseline 'no response' value after being removed from the agent. With some instruments, the recovery time increases significantly after extended exposure to high concentrations of agent. Ideally a detector should recover in a short period of time (minutes)¹².

3.1.2.3 Calibration Requirements

Verification of a detectors' capacity to perform is usually required every time it is turned on¹². This process is usually conducted using a known non-toxic chemical as a simulant of the targeted compound¹².

Ideally the proper operation of a detector can be verified with simple simulant checks that do not require complicated correlation calibration procedures before each use¹².

3.1.2.4 Portability

Portability, or whether a device can be transported, includes the portability of any support equipment required for operation¹². Field detectors must also be durable enough to enable transportation from place to place by ground, rail, water and air transport¹².

3.1.2.5 Power Requirements

The most common power supplies for field deployable detectors are batteries, however some detectors may require specifically designed batteries, and finding replacements or recharging spent batteries in the field may prove to be quite difficult¹². Ideally a detector should be operable through the use of two or more alternative power sources, and battery life must be sufficient to last throughout an entire mission¹².

3.1.2.6 *Simple User Interface*

The assessment of a detector's performance also needs to take into consideration the concept of use, including how the information generated will be used, the level of training of users and the environment in which a detector will be used^{9, 12}.

Equipment to be used by first responders at the scene of an incident needs to give as unambiguous a result as possible⁹. Many field detectors may show graphs or other indicators on displays that represent certain concentration levels, however they do not directly display the concentration level of target chemicals that produce alarms¹². As such, a certain degree of data interpretation may be necessary to determine whether the data obtained from a given device is valid¹².

Although most field detectors are designed to be user friendly and require very little training to operate and maintain them, detailed knowledge of a detector's characteristics will enable the likelihood of false alarms to be assessed¹².

3.1.2.7 *Ongoing Costs*

Ongoing costs associated with a detector should be carefully explored and should include equipment purchases, maintenance and consumables. Cost comparisons should be based on the cost per analysis per chemical¹².

3.1.3 *Summary*

Presently there is no single detector which has all the desirable capabilities and performance functions, and currently available detectors all vary considerably in cost, performance and reliability. As such care must be taken to select a detector based on the abovementioned factors and operational requirements. Furthermore, many detector manufacturers make claims based on their own testing, some of which have not been thoroughly verified by third party laboratories¹².

4. Ion Mobility Spectroscopy (IMS)

IMS-based detectors are the most commonly deployed detectors for chemical monitoring by the military^{12, 27}. Furthermore, IMS-based chemical detectors are now commercially available and are being utilised by civilian agencies for the field detection of TICs, illicit drugs and explosives. More recently, IMS has also been employed as a research tool in the analysis of biological materials, specifically in proteomics and metabolomics^{12, 28, 29}.

4.1 IMS Technology

IMS is a separation technique that allows ionised analyte molecules to be distinguished on the basis of their mass, charge and mobility in the gas phase³⁰. Hence, IMS instruments are quantitatively capable of detecting and identifying vapour-phase CAs and their degradation products²².

A typical IMS, shown in Figure 1, comprises a drift tube which is normally divided into an ionisation region and a drift region, which is where the separation and detection of ions occur. The ionisation and drift regions are separated by a gating or shutter grid which is used to pulse the ions produced in the ionisation region and inject them into the drift region²⁹.

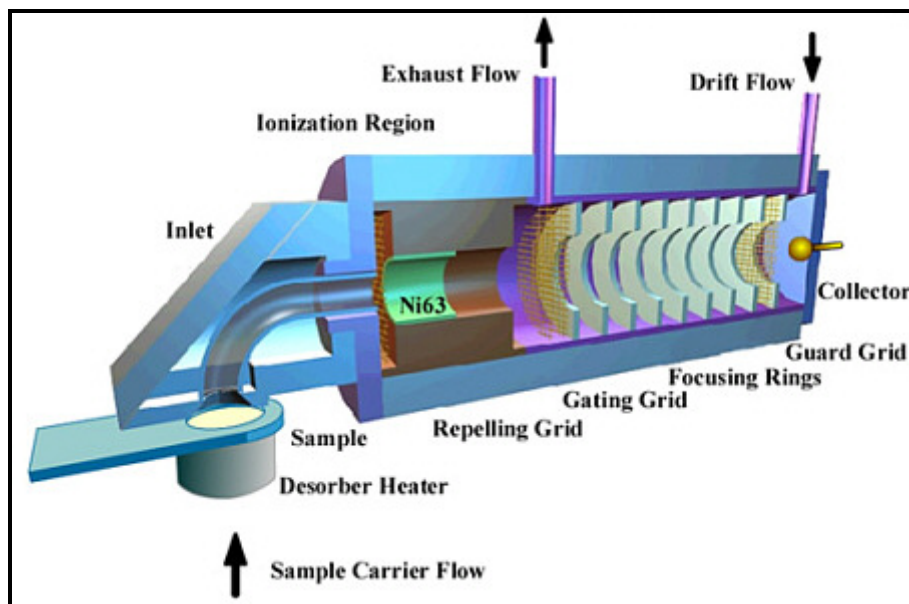

Figure 1: Schematic of Ion Mobility Spectrometer³¹

IMS operates by drawing a sample vapour into the detector via an inlet^{12, 15}. However, for a detector to perform optimally, the detector must be operated in clean, dry air^{12, 32}. Membrane inlet interfaces and/or molecular sieve packs have been used extensively in CA monitoring as they limit the entry of moisture, dust and other particulates into the drift cell whilst allowing compounds of interest to pass through. These membranes allow chemicals in the sample to diffuse through them into the ionisation region whilst water molecules and other chemicals that have a low permeation rate will be carried away by the exhaust flow¹². One disadvantage with these membranes is that they may also lead to diminished sensitivity and increased response time²⁹.

Upon entering the ionisation region a sample vapour is ionised under atmospheric conditions. Various ionisation sources can be used, however, the most prevalent is usually a beta-emitter radioactive source, such as Nickel-63^{12, 27, 29, 32, 33}. Nickel-63 has been the favoured source for IMS owing to its high stability, noise free operation, lack of demand for power, mechanical and physical stability and intrinsic safety in explosive atmospheres²⁹.

The ionisation reaction begins when high energy beta particles, released from the Nickel-63 source, react with nitrogen and oxygen in the air, creating reactant ions by atmospheric pressure chemical ionisation (APCI)^{12, 27, 30, 34}. When a sample vapour is introduced into the ionisation region of an IMS, the neutral compounds in the sample undergo ion-molecule reactions with the reactant ions to form product ions^{29, 30, 34}. To further enhance a detector's selectivity a reagent ion or dopant may be added to the drift gas, the latter being a dry air flow, introduced at a constant pressure and flowing in the opposite direction to the ion drift. This results in collisions between the ions and the molecules in the drift gas, thus impeding the ions' progress toward the collector^{12, 30}.

Common doping agents for IMS detectors include ammonia and acetone for CA detection, chlorinated solvents for explosives and nicotinamide for narcotic detection³⁰. Acetone is an extremely common dopant used in military IMS detectors as it prevents the formation of ions from some compounds such as hydrocarbons that would interfere with a detection process but still allows formation of ions from CWAs. This results in fewer species being ionised and therefore much interference is eliminated^{27, 35}.

The next step is the migration of the ions in an electric field into the drift region, where the ions are separated based on their ionic mobility²⁷. The generated ions enter the drift region via very short pulses controlled by an electronic gate^{12, 27, 30}. When the gate is open, the electric field is removed thus allowing ions to enter the drift region, however not all ions are able to be injected into the drift tube when the gate is open. The mode of detection, positive or negative mode, dictates which ions will be able to enter the drift region and is dependent upon the electrical field gradient between the ionisation region and ion collector. For example when the ion collector side has a higher voltage than the ionisation side, the instrument is said to be in negative mode, therefore only negative ions are injected and vice versa for positive ions^{12, 32}. Furthermore, this electrical field gradient can be alternated between positive and negative mode to permit detection of both positive and negative ions¹².

On entering the drift tube, the ions are subjected to a uniform, weak electric field, which accelerates them towards a collector situated at the end of the drift tube, as shown in Figure 1³⁰. At this ion collector the ions collide and release their charge, which is registered as a current^{12, 15, 23}. The electric current generated is then processed by a signal processor into a series of peaks representing the relative drift times for the various substances. Drift time is the time interval between when the ions are injected into the drift region and when the ions collide with the collector¹². Hence the drift time is controlled by the collision frequency and as expected, larger ions will experience more collisions than smaller ones and will take longer to traverse the drift tube³⁰. Due to the IMS not being operated under vacuum the observed drift time is usually in the order of milliseconds¹². The plot of the current generated for a series of peaks over time is referred to as an ion mobility spectrum, an example of which is presented in Figure 2. The intensity (height) of the peaks in the spectrum corresponds to the amount of the charge, giving an indication of the relative concentration of any agent present^{15, 23}.

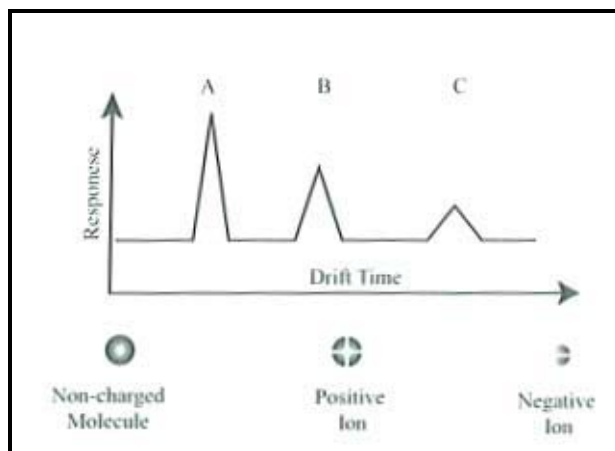

Figure 2: Schematic of Ion Mobility Spectrum¹²

The signal processing system correlates the relative drift time and signal characteristics of the sample and compares the results to the detector's internal libraries for pattern matches¹². The substance will be reported as detected and an alarm generated when the information matches the criteria set and stored in a detector's library¹².

4.2 Advantages

Currently, ion mobility technology is predominately used for the field detection of explosives, illicit drugs and CAs. IMS detectors are used at many airports for screening luggage for the presence of explosives or illicit drugs, whilst the military and emergency responders utilise IMS detectors for CAs and explosives^{12, 36}.

The principle advantages of IMS are its simplicity and sensitivity³⁶. IMS-based detectors are portable and provide rapid analysis and response. Furthermore they are highly sensitive, have low limits of detection and are relatively inexpensive to manufacture^{12, 36}.

IMS detectors have a simple design and are quite rugged. They contain few moving parts, are lightweight, have low power consumption and use limited consumables³⁶. IMS utilises a weak radioactive ionisation source to provide the ionisation energy thus enabling the instrument to be miniaturised for field operations. In addition the detectors do not require any specialised power supplies, additional carrier gases or vacuum pumps^{12, 36}.

The general operation and maintenance of an IMS detector is also quite simple, requiring minimal training. The initial setting up of a detector requires a battery pack to be inserted and the detector to be turned on. After a warm-up period, the detector will perform a self-test, which verifies that proper operational parameters are satisfied. It can then be calibrated using simulants¹². If a target substance is detected, an alarm is triggered thus allowing minimal or no data interpretation¹².

IMS has gained a reputation as being the best technique to detect very low levels of toxic vapours on the battlefield. The limit of detection for most CA vapour samples is in the parts per billion (ppb) to low parts per million (ppm) range, with a response time of a few

seconds¹². IMS-based detectors are non-selective but have a high identification power due to their ability to separate ions in their drift tubes. They are capable of identifying a range of environmental contaminants or vapours under a variety of conditions thereby making them well suited for field measurements^{6, 12}.

4.3 Disadvantages

Although IMS, as a technique, is fast, relatively sensitive, and instruments can be hand portable if necessary, it can suffer from poor selectivity and is prone to interferences which produce false alarms^{27, 37}.

IMS uses a non discriminatory ionisation process and therefore is subjected to potential interferences by non-target compounds. Thus, it may be necessary to use more than one peak for substance identification which will improve a detector's identification capability and minimise its potential for false alarms¹². Furthermore, limitations on the resolution or separation capacity of IMS detectors which are the result of short drift tubes, means that the number of targeted compounds programmable for detection must be limited to avoid peak overlapping. This leads to detection interference and frequent false alarms¹².

Although IMS has been found to be reasonably sensitive for low concentration samples, if the concentration of the compound of interest reaches a certain level, detectors can become saturated and a further increase in concentration will not lead to a much stronger signal¹². IMS is also quite susceptible to instrument contamination leading to long clearance times³⁶.

Temperature, pressure and humidity may also have a significant effect on the performance of an IMS-based detector. Temperature affects ion mobility causing peak positions to shift and when the shift is significant, the detector may fail to identify the targeted chemical^{12, 36}. Humidity levels affect the species entering the ionisation region as various chemicals can be hydrated to form water clusters and as a result, form different ions. Therefore the observed peaks, under high humidity, may shift away from the position observed at low humidity^{12, 36}. Furthermore the direct analysis of mixtures in IMS can lead to complex spectral patterns which are difficult to interpret³⁸.

4.4 Existing IMS-Based Field Detectors

At present there are a number of field detectors that incorporate IMS technology, all of which are quite similar in their capabilities. They include the Chemical Agent Monitor (CAM), Advanced Portable Chemical Agent Detector (APD 2000), Multi-IMS, Rapid Alarm and Identification Device – Monitor (RAID-M), IMS-2000, GID-3 also known as Automatic Chemical Agent Detection Alarm (ACADA), SABRE 4000 and the lightweight chemical detector (LCD).

4.4.1 Chemical Agent Monitor (CAM)

The CAM, shown in Figure 3, is manufactured by Smiths Detection (Watford, UK) and was the first mass produced, reliable hand-held instrument capable of detecting nerve and blister agents. It is now heavily deployed around the world⁶. A number of variants have been

manufactured which have incorporated product improvements, including the Improved Chemical Agent Monitor (ICAM), Enhanced Chemical Agent Monitor (ECAM), CAM-2 and CAM Plus³⁹.



Figure 3: Chemical Agent Monitor (CAM)⁶

The CAM is not able to identify a specific agent, but gives an indication of the class of agent present. As a result, it is mostly used to survey an area exposed to a CA and confirm the extent and relative concentration of any contamination. It can also be used to monitor chemically exposed personnel, vehicles, equipment and terrain to determine the extent of any cross contamination, and confirm the effectiveness of decontamination^{39, 40}.

CAM is easy to use with a simple ON/OFF switch and a mode button to switch from blister ('H' mode) to nerve ('G' mode) agent detection⁴¹. However, the required mode must be manually selected as the CAM is incapable of simultaneously detecting nerve and blister agents⁴¹.

The hazard level is shown on a liquid crystal display (LCD), via an increasing number of lighted bars. The number of bars indicates the degree of hazard which can also be related to the relative concentration, with one to three bars indicating a low concentration, four to six bars a medium to high concentration and seven to eight bars indicating a very high concentration⁴¹.

According to the manufacturer, the CAM is a lightweight, handheld detector that can detect and differentiate between low levels of nerve and blister agents. It requires minimal training, has a simple user interface and is easy to maintain⁴².

Evaluation of the CAM by scientists at Edgewood Chemical Biological Center (ECBC) found that it can detect nerve and blister agents below the IDLH level of 0.03 mg/m^3 (nerve agents), but cannot detect them at the AEL concentration level, which is 0.0001 mg/m^3 and 0.003 mg/m^3 for nerve and blister agents, respectively. The detectors were also found to successfully detect CAs at different temperatures and humidities⁴¹. However, the CAM was found to produce an alarm in the presence of a number of interfering vapours, giving a visual bar warning with no audible warning⁴¹.

4.4.2 APD 2000

The APD 2000, shown in Figure 4, is a lightweight, handheld, portable detector manufactured by Smiths Detection (Watford, UK). It was designed for surveying the environment to identify specific CAs and irritants. It is currently used by law enforcement agencies, first responders and HAZMAT Response Teams in the United States of America^{43, 44}.



Figure 4: APD 2000⁴⁴

Smiths Detection claims that the APD 2000 has superior resistance to interferents. It can simultaneously detect nerve and blister agents, and by simply switching to irritant mode, it can also recognise pepper spray and mace as well as identify other hazardous compounds⁴³⁻⁴⁵.

The manufacturers further claim that the APD 2000 is able to either monitor or detect CAs, has a visible and audible alarm and requires little training and maintenance⁴⁴. It requires no daily calibration and takes approximately three minutes, after it has been switched on, to complete a self-test and go into standby mode⁴³. Its performance can then be verified using the confidence test sampler provided by the manufacturer⁴³. It has the added feature of a 'back-flush' pump that reverses the sample flow path to protect the cell assembly from gross contamination. However when it is in this mode the detector ceases to actually detect⁴³.

The APD 2000 has a display that gives a numerical reference level (between zero and 100) reading as well as the identity of the substance detected. The larger the reference level number is, the higher the concentration of the suspected vapour. The ranges of numerical values, which will trigger an audible alarm, for low, medium and high agent concentrations are 26-50, 51-75 and 76-100 respectively⁴³. Responses below 25 will not trigger an audible alarm but the display will indicate that an identified substance has been detected at a low concentration⁴³.

An evaluation of this detector by scientists at ECBC found that the APD 2000 responded consistently to very low concentrations of CAs and had a minimum detectable level of approximately an order of magnitude lower than the IDLH value but still higher than the AEL levels⁴³.

The major problems associated with this detector occurred at low temperatures. At -30°C the display was illegible, making it impossible to get the detector into the correct operational mode. Also the batteries failed to provide sufficient operational power due to the excessive power consumption required to operate the detector at these temperatures, and although the APD 2000 provided consistent CA detection sensitivity it also had a very high false alarm rate⁴³.

4.4.3 Multi-IMS/ ChemPro 100 / ChemRae

The Multi-IMS, ChemPro 100 and ChemRae, shown in Figure 5 are chemical detectors based on Open Loop IMS technology. Open Loop IMS technology differs from conventional IMS since in the open loop design there are no molecular sieve packs which require routine replacement^{46, 47}. The manufacturers claim that this variation of IMS technology provides improved sensitivity and selectivity^{46, 47}. Furthermore, it has been stated that the internal sample pump provides extremely quick response and recovery times^{46, 47}.

The Multi-IMS is manufactured by Dräger (Lübeck, Germany) for use by fire brigades, police forces, customs and civil defence forces and is not available for purchase by federal agencies. As a result, the ChemPro 100, which is manufactured by Environics (Toronto, Canada) is available for use by federal agencies^{46, 48, 49}. The ChemRae is manufactured by RAE Systems (San Jose, CA) and was designed for use by first responders⁴⁷.



Figure 5: (A) Multi-IMS⁴⁶, (B) ChemPro 100⁴⁹, (C) ChemRae⁴⁷

The manufacturers state that these detectors are able to not only identify agent class (nerve, blister, blood, etc) but also give an indication of the relative concentration, and monitor whether the concentration is increasing or decreasing⁴⁶⁻⁴⁹. These detectors are compact, robust,

lightweight, handheld detection and identification systems that are designed to detect the smallest traces of CAs and TICs⁴⁶⁻⁴⁹.

The systems have an easy to use operator interface with a detailed display which provides the operator with a battery life indicator, detected agent class, agent concentration at LOW/MEDIUM/HIGH level, level of audible alarm, date and time⁴⁶⁻⁴⁹. Furthermore these detectors are also capable of storing agent alarm information for retrieval at a later time thus providing a historical log of events⁴⁶⁻⁴⁹.

The operation of the detectors is driven by a three button keypad and requires only one hand, and the start-up procedure simply requires opening the air cap (by rotating 180 degrees). The power button is then pushed for three seconds and when the display shows 'ready' the detector is operational^{46, 49}.

The ChemPro 100 has a 'conditioning mode' which keeps the instrument from responding whilst stabilising. However, the presence of this mode is only apparent from the data displayed on a connected computer and is not evident to the operator using the detector as a hand-held device. Therefore the length of time that the detector is off-line would be unknown to the operator⁴⁸.

The ChemPro 100 has been evaluated by scientists at ECBC and was found to have a response time of between 15 and 225 seconds depending upon the agent, and a recovery time of typically less than 50 seconds⁴⁸. However, when evaluating two ChemPro 100 detectors simultaneously it was found that, in many instances during the testing, the units produced very different responses to an identical CA vapour challenge. Furthermore, when exposed to a selected CA, it was observed that the detectors failed to respond when the agent was present; the warning alarms occasionally stopped even though the CA was still present and the detectors failed to clear an alarm even after the challenge vapour was replaced with clean air. It was also noted that at elevated humidity the accuracy of the detectors decreased⁴⁸. A DSTO evaluation confirmed these issues and also found this detector to be insensitive to specific CAs⁵⁰.

The detectors were also found to produce both positive and negative false responses to a number of common indoor interferent vapours, such as ammonia and air freshener. In the instances of a false negative response, the detector usually presented a protective warning, even though the compound was inaccurately identified⁴⁸.

4.4.4 Raid-M and Raid-M-100

The RAID-M-100 pictured in Figure 6 (A), is based on the RAID-M which is shown in Figure 6 (B). Both detectors are manufactured by Bruker Daltonics, Inc. (Bremen, Germany) and are currently in use by the German and Danish military⁵¹. These detectors are IMS-based and are able to detect, classify, quantify and continuously monitor concentration levels of dangerous vapours specified in their library, whilst being operated single handedly^{51, 52}.



Figure 6: (A) *Raid-M-100*⁵², (B) *Raid-M*⁵²

Both detectors have been designed to automatically alternate between positive and negative mode every two to three seconds. As such they can both be used to monitor CWA and TIC contamination on personnel or equipment in the field and within collective protection facilities⁵³.

Once the detector is switched on, it will perform a self test and if successful will automatically start measuring in 'sample' mode. Once in this mode, the detector's operation is checked with the confidence samples provided; no other daily instrument calibration is required⁵⁴.

Detected substances can be displayed as the agent class or specific agent, simulant or TIC, with hazard levels being indicated by an 8-bar incremental display. Each bar corresponds to a certain concentration level depending upon the chemical vapour detected. When an agent is identified the RAID-M gives a visual and audible alarm, which can be muted if required^{51, 52}. When the amount of CA or simulant reaches a preset level, the RAID-M will automatically enter back flush or purge mode which contributes to its short recovery time of between 15 and 70 seconds⁵¹⁻⁵⁴.

Scientists at ECBC have evaluated the RAID-M and found that it can detect CAs below the IDLH levels but higher than the AEL levels, in response times of less than one minute^{53, 54}. Temperature and relative humidity have been found to have a minimal effect on response times for detecting CAs. However at extreme low and high operating temperatures, as stated by the manufacturer, there was a decrease in sensitivity for certain agents. For example, there was approximately a six-fold and a 17-fold loss of sensitivity for HD at the low and high temperatures, respectively. However, it was noted that the detectable levels were still at or below the IDLH⁵⁴.

Although the RAID-M offers fast and sensitive detection, the number of false responses to interferences still poses a concern⁵⁴. It is not known as yet whether the selectivity has been improved with the RAID-M-100 version⁵⁵.

4.4.5 IMS 2000

The IMS 2000, shown in Figure 7, is a CA monitor manufactured by Bruker Daltonics, Inc. (Bremen, Germany) for use by military and industry. It is used to monitor both personnel and equipment, determine contaminated areas, identify agents and confirm successful decontamination^{56, 57}. It can also be used with a laptop computer to enable precise determination of the nature of contamination⁵⁷.

The IMS 2000 is designed to be used as a handheld or vehicle mounted detection system. The detector is equipped with an anti shock system for use on vehicles, which suppresses the influence of mechanical vibrations. Furthermore it has built in pressure compensation which allows it to be operated on helicopters or aircraft^{56, 57}.



Figure 7: IMS 2000⁵⁷

The IMS 2000 can be easily decontaminated and mounted, and has components which can easily be replaced⁵⁶. It is encased in a full metallic housing which ensures maximum stability and it has a built in test capability to further guarantee stable operation under all conditions^{56, 57}.

The detector is easy to operate and is controlled by two switches, located on the left and right of the LCD window. The switch located on the left turns the power on. To navigate through the menu of options and to operate the detector, both switches are pressed together⁵⁸. The detector switches automatically and continuously between nerve and blister agent detection every two seconds⁵⁸.

The detector has two modes, the 'all-clear' and 'continuous monitoring' modes. The 'all-clear' mode is the more sensitive of the two as the detector is set to take measurements in a fixed time period and is generally used for monitoring low levels of toxic contaminants. In 'continuous monitoring', the detector can be used on moving vehicles and in fixed installations⁵⁶. The difference between the two modes is the number of hazard level bars visualised, with the 'all-clear' mode having a wider hazard level bar range⁵⁸. The hazard level bars indicate the detection response by an increasing number of lighted bars on the LCD. The detector has both an audible and visual alarm with the audible alarm being sounded when two or more bars are indicated⁵⁸.

The detector has minimal warm-up time and fast recovery time and requires no daily instrument calibration, only a confidence check utilising samples provided by the manufacturer. It is designed to require minimum maintenance as it is equipped with a powerful diagnostic program which can monitor and analyse internal data⁵⁶. The system is also equipped with a self protection back-flush routine to protect it from contamination⁵⁶.

The IMS 2000 is able to detect CAs, in less than two minutes, at or below the IDLH levels but is unable to detect agents at the AEL levels. Evaluation of this detector by scientists at ECBC, found that at higher temperatures, higher concentrations of agent were required to produce an alarm. It was found that relative humidity had no effect on the detector's response to G-agents but did have an effect on the detection of HD. At low humidity there was an improved minimum detectable level for HD, whilst higher relative humidity required a higher concentration of HD to produce a response⁵⁸. The detector was also found to exhibit false positive responses to most of the smoky interferences tested⁵⁸.

4.4.6 GID-3

The GID-3, also referred to as the M22 ACADA, shown in Figure 8, is manufactured by Smiths Detection (Watford, UK) and has been described as being the most advanced CWA detector fielded by the US Armed Forces⁵⁹.



Figure 8: GID-3⁶⁰

The GID-3 was originally developed after the Gulf War (1990-91) to overcome perceived weaknesses in existing detectors, namely the inability of detectors to simultaneously detect nerve and blister agents. As a result this detector contains design features that have improved its agent detection capability, reduced false alarms, allowed for better agent discrimination and identification and improved ease of use by deployed troops⁶⁰.

The GID-3 has two completely independent spectrometers, shown in Figure 9, both of which have their own ionisation sources allowing the GID-3 to detect positive and negative ions

simultaneously. It responds to agents in real time and is capable of being reprogrammed to meet further threats from blood and choking agents⁶⁰.

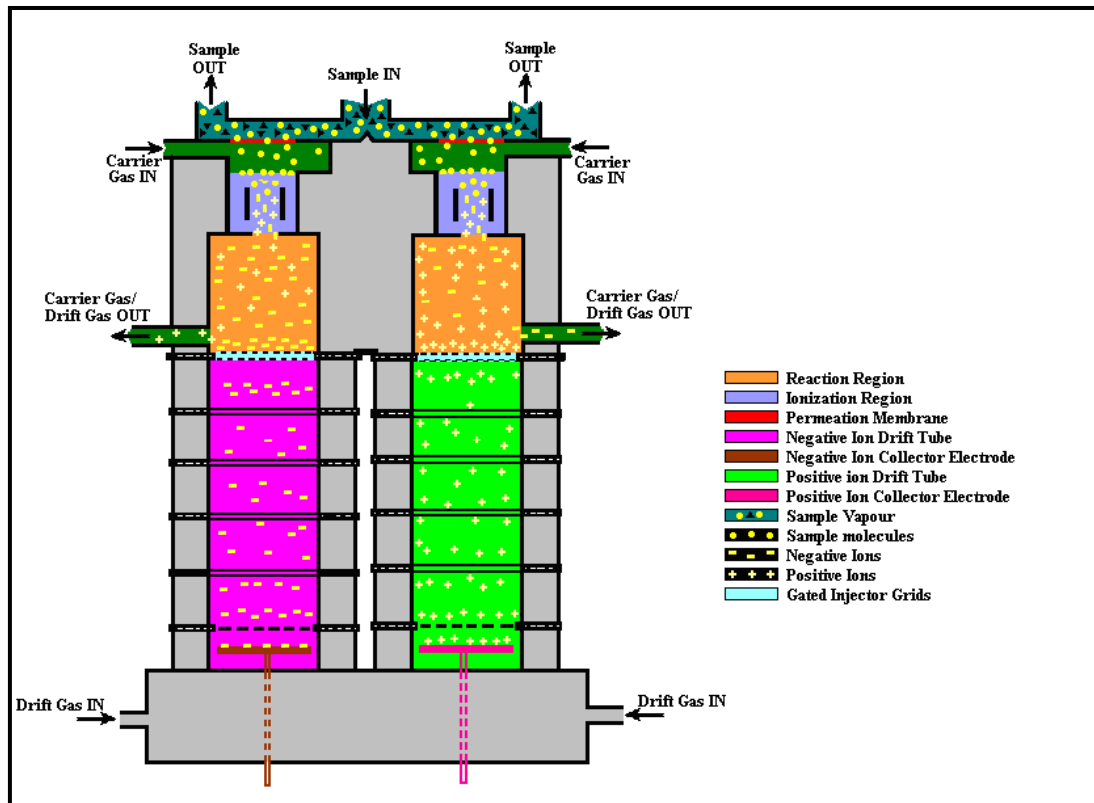

Figure 9: GID-3 schematic⁶¹

The GID-3 is easy to use, rugged, reliable and the most widely deployed detector currently in production^{59, 60}. It indicates the presence of CAs and the level of threat, whilst operating continuously with quick response and clear down times. It also provides a visible and audible alarm both locally and at remote locations^{59, 60}.

The GID-3 can be installed on vehicles and can be deployed for use in man-portable or static locations⁶⁰. In a reconnaissance role the GID-3 is normally fitted in the crew compartment of a vehicle where it samples the external atmosphere via a sensor head⁵⁹.

4.4.7 Sabre 2000 and Sabre 4000

The Sabre 4000, shown in Figure 10 (A), is a handheld trace detector for explosives, CAs or narcotics and is manufactured by Smiths Detection (Watford, UK)⁶². It is the updated variant of the Sabre 2000, shown in Figure 10 (B), which was originally developed by Barringer Technologies, Inc.



Figure 10: (A) Sabre 4000⁶², (B) Sabre 2000⁶³

The Sabre 4000 can detect and identify over 40 threat substances, including CAs, explosives and narcotics, in approximately 15 seconds. Furthermore, it can analyse trace particle samples as well as vapour samples⁶². At present there is limited information available on the effectiveness of this detector in the field, in the presence of interferents, and under varying temperatures and relative humidity. However there is a wide range of available information on the Sabre 2000.

The Sabre 2000 is a lightweight, handheld detector that is capable of detecting and identifying specific CAs, explosives and narcotics. It has an audible and visual alarm and can store results from analysis for later retrieval using a computer⁶³.

Once turned on, the instrument completes a self-test and begins warming up, which typically takes approximately 30 minutes. Detector performance is then verified by the operator using a confidence test sample and the detector is then set to the desired detection and sampling modes⁶³.

The Sabre 2000 can operate in either positive or negative mode requiring one of two cartridges to be inserted prior to operation, to give the desired detection mode. As such, it cannot simultaneously detect nerve and blister agents⁶³. In addition, the detector has two vapour sampling and detection modes comprising a particle sampling/sniff mode and a vapour sampling/pre-concentration mode⁶³.

In sniff mode the instrument can sample a vapour, or monitor a surface for contamination and produce a result in approximately 10 seconds⁶³. However, for particle sampling in sniff mode, a 'shark skin' sampling card is used to wipe a suspected contaminated surface. The swab is then inserted into a slot on the top of the instrument, where any contaminant is thermally desorbed. Pressing 'start' initiates the analysis by drawing the desorbed vapour into the IMS cell⁶³.

In pre-concentration mode, a 'vapour card' or cartridge is placed in the card slot of the detector. Vapour is then drawn directly through the instrument and concentrated on this cartridge for a designated period of not more than 30 seconds. Analysis begins when the sample is thermally desorbed from the cartridge and vapour drawn into the IMS cell⁶³.

Evaluation of the Sabre 2000 by scientists at ECBC found that the threshold sensitivity of the detector is better than IDLH levels but unable to meet AEL detection requirements of the agents tested. In addition it was found that, depending upon the selected mode of operation, the response time of the detector was between 10 and 40 seconds⁶³.

It was also found that in high humidity, the detector was unable to detect HD consistently, and when tested near the minimum detectable limits of nerve agents, it was found to give inconsistent responses. After extended operation in a high humidity environment the air purification cartridge located at the back of the detector required replacement⁶³. Cold temperatures caused erratic detector responses at the minimum detectable levels of the agents tested, and necessitated longer recovery times⁶³. However the Sabre 2000 exhibited few false responses to the interferent substances tested⁶³. It is not known if the Sabre 4000 has overcome the above mentioned problems associated with the Sabre 2000 as it has not yet been independently evaluated.

4.4.8 LCD-3

The LCD-3, shown in Figure 11, is a personal chemical detector, manufactured by Smiths Detection (Watford, UK)⁶⁴. It has been designed to act as a local warning alarm for individuals and small groups of soldiers and can be handheld whilst wearing IPE or can be operated inside its carry pouch which can be attached to clothing^{64, 65}. It can withstand the stresses and shocks associated with both operational use and transport by road, sea and air⁶⁶.



Figure 11: LCD-3⁶⁴

It detects, identifies, quantifies and warns personnel of CA threats at/or below attack concentrations^{64, 65}. It is generally operational within five minutes of switching on, including warm up time and self testing, and requires no daily calibration. Operating performance is verified by using the confidence samples provided⁶⁶. In operation the LCD-3 samples the air continually, and can thus simultaneously detect nerve and blister agents and simulants, usually within 10 seconds⁶⁵.

It has an audible and visual alarm which alerts personnel to the need for IPE and because it operates continuously, it recovers rapidly thereby providing constant real time detection of CAs⁶⁵.

4.5 Comparison of IMS Based Detectors

There are a number of commercially based IMS based detectors available each having associated advantages and disadvantages. Table 4 summarises the abovementioned detectors' capabilities against a number of assessment criteria so that a quick comparison can be made. The list is not comprehensive and therefore does not contain all the IMS based detectors available. Rather, it covers those that are well-known or currently in service in Australia.

Table 4: Assessment Criteria for Currently Available IMS detectors

Criteria	CAM	APD 2000	Multi-IMS	Raid-M-100	IMS 2000	GID-3	Sabre 4000	LCD-3
Detected Agents	Blood, Blister, Choking and Nerve agents plus selected TICs ³⁹	GA, GB, GD, VX, HD, L, Pepper spray & Mace ⁴⁴	Nerve, Blister, Blood and Choking agents ⁴⁶	GA, GB, GD, GF, VX, HD, HN, L, AC TICs: Chloride, Cyanide, SO ₂ , Toluene diisocyanate, Arsine ⁵¹	GA, GB, GD, Blister agents including L ⁵⁶	GA, GB, GD, VX, HD and L. Programmable. TIC detection optional ⁵⁹	GA, GB, GD, GF, VX, Vesicants, TICs, Drugs & Explosives ⁶²	Nerve, blister & blood agents. TICs ⁶⁴
Limits of Detection	LODs in line with or exceed the NATO requirements ^{6, 39, 40}	V agents - 4ppb; G agents - 15ppb; H - 300ppb; L - 200ppb ⁴⁴	Nerve-0.01-0.1mg/m ³ ; Blister-0.5-2.0 mg/m ³ ; Blood/choking- 20-50 mg/m ³ ⁴⁶	Low ppb up to several ppm ⁵¹	Nerve - 20µg/m ³ ; Blister - 200µg/m ³ ⁵⁶			LOD in line with or exceed the NATO requirements ⁶⁴
Simultaneous Detection	No ³⁹	Yes for nerve and blister agents. To detect irritants the mode must be manually changed ⁴⁴	Yes ⁴⁶	Yes ⁵¹	Yes ⁵⁶	Yes for nerve, blister, blood and choking agents and TICs ⁵⁹	No ⁶³	Yes ⁶⁴
Portability and weight	Hand-held, weighs <2kg with battery ^{6, 39, 40}	Hand-held, weighs <3kg with batteries ^{44, 45}	Hand-held, weighs <800g with battery ⁴⁶	Hand-held, weighs <3kg	Hand-held, weighs <3kg with battery ^{56, 58}	Vehicle mounted and use by dismantled troops, weighs <7kg with battery ⁵⁹	Hand-held, weighs <3.5kg with battery ⁶²	Small, lightweight, weighs <500g ⁶⁴
Power Requirements	Single 6V rechargeable lithium-sulfur dioxide battery or 12V power supply ^{6, 39, 40}	6 standard 'C' alkaline batteries ⁴⁴	Rechargeable lithium-ion battery ⁴⁶	Rechargeable lithium- ion battery pack ⁵¹	Lithium manganese dioxide batteries or power supply ⁵⁶	Lithium-sulfur dioxide battery, rechargeable battery or mains power supply ⁵⁹	Rechargeable lithium- ion battery or mains power supply	4 x AA Lithium iron Disulphide or 4 x AA Alkaline Manganese Dioxide batteries or power supply ⁶⁴
Operational Life	14 hours continuous at 20°C ^{6, 39, 40}	6-8 hours ^{44, 45}	10 hours ⁴⁶	Minimum battery life of 6 hours intermittent use in a 24 hour period at 10°C to 49°C ⁵¹	16 hours, however has an auto shutdown feature after 15 mins ⁵⁶	14 hours continuously ⁶⁰	4 hours ⁶²	Alkaline batteries - 30 hours above 10°C. Li batteries - 40 hours above 10°C ⁶⁵
Operational Temperature Range (°C)	-25 to +55 ^{6, 39, 40}	-30 to +52 ⁴⁴	-30 to +50 ⁴⁶	-30 to +50 ⁵¹	from -25 ⁵⁶	-30 to +50 ⁵⁹	0 to +45 ⁶³	-31 to +55 ⁶⁴

5. Flame Photometry

Flame Photometry is an important CA detection technique that has been successfully used for a number of years¹². Flame Photometric Detectors (FPDs) are deployed in military forces and civil agencies worldwide, however they are more commonly found integrated with a gas chromatograph (GC) in the laboratory^{12, 67, 68}. GC-FPD is used routinely for clinical, biological and environmental analyses. To date, GC-FPD has been one of the most useful methods in determining the CWA concentrations in samples sent to a laboratory for confirmatory analysis¹².

5.1 Flame Photometric Detection Technology

Flame photometry is an atomic spectroscopy technique based on the light emission properties of excited atoms or clusters as they return to lower energy states¹².

A basic schematic of a portable FPD device is shown in Figure 12.

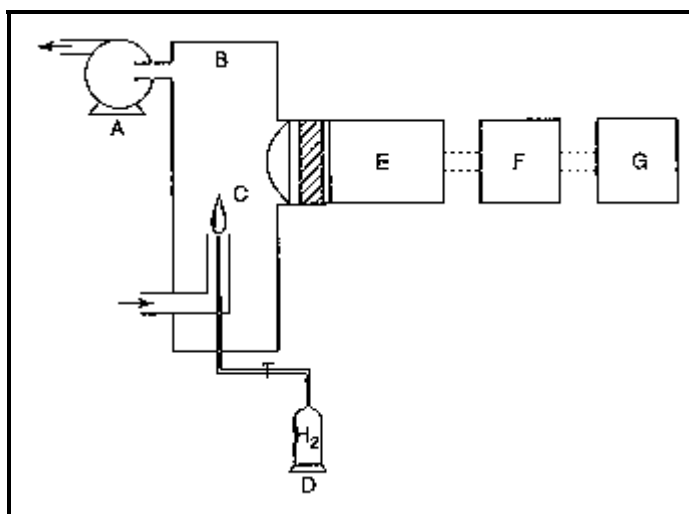

Figure 12: Schematic Representation of an FPD Device (A=air pump, B=reaction chamber, C=flame, D=hydrogen supply, E=photometric cell, F=electronics, G=display)⁶⁸

Initially, air is drawn into a reaction chamber by an air pump (B and A, respectively, in Figure 12)⁶⁸. The sample is then burned in a hydrogen-rich flame and the compounds present emit light of specific wavelengths. This, in turn, produces a characteristic emission spectrum that serves as a fingerprint for the atoms in the compound analysed^{22, 55, 67, 68}. Figure 13 shows an example of the main emission bands for sulfur, phosphorus, sodium and potassium.

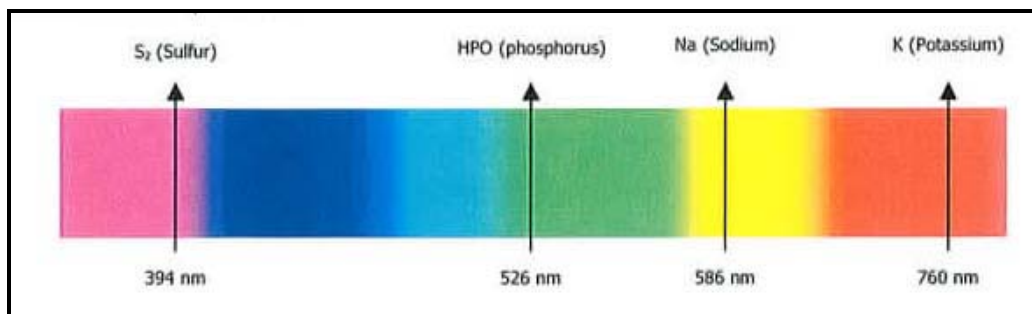

Figure 13: Example of main emission line (or band) from sulfur, phosphorus, sodium and potassium between 350 and 800 nm⁶⁷

An optical filter is selected to allow a specific wavelength of light to pass through it and a photosensitive detector then produces a representative response signal. Since most elements emit a unique and characteristic wavelength of light when burned in this flame, the detection of specific elements is facilitated^{12, 15, 22, 68}.

Phosphorus and sulfur are the key components in nerve agents and HD, respectively. Hence CA detectors based on FPD have optical filters that are specific for these two elements. When phosphorus-containing compounds are burnt in a hydrogen-rich flame, excited phosphorus (in the form HPO*) species are formed, whereas sulfur-containing compounds form excited S₂* species. When these species fall back to their ground state light is emitted near 526nm for the HPO* species and 394nm for the S₂* molecule (see Figure 13)^{12, 68}.

5.2 Advantages

Ordinarily, the average concentration of organophosphorus and/or organosulfur compounds, other than CWAs, in the atmosphere will be very low. Hence FPDs are subject to very little interference and therefore able to provide adequate detection of phosphorus or sulfur atoms in the environment. FPDs are very specific and sensitive for sulfur and phosphorus compound detection with the LOD for CWAs, without prior separation using a GC column, being ppb to ppm^{12, 68}.

FPDs provide a means for real time, or instantaneous, detection of CAs due to the continual flow of air being drawn through the detector. Furthermore no waste is generated as the toxic sample drawn into the detector is decomposed, and therefore detoxified, when it is burned in the hydrogen flame⁶⁹. Due to the destruction of the sample by the flame, these detectors do not suffer from memory effects, and even if a high concentration of CA is detected the sensitivity to all detectable elements will be recovered a few seconds later^{12, 70}.

A further advantage with this technique is that hydrogen is a low noise flame and therefore when it combusts with air it produces few emission lines in the UV spectrum and does not interfere with sulfur or phosphorus emission. Finally, both elements can be detected simultaneously because they emit light at different wavelengths^{12, 70}.

Handheld FPDs do not require any sample preparation, as a vapour sample is drawn directly from the surrounding air and provides a content analysis instantly⁶⁹. Furthermore, they require little maintenance and are ready to use in a short time¹².

5.3 Disadvantages

One of the major disadvantages associated with FPD is that they only detect compounds containing phosphorus and/or sulfur and as such do not detect CWAs and related compounds that do not contain these elements⁵⁵.

Furthermore, although flame photometry is highly sensitive it is still prone to false positive results. Since only the characteristic light wavelengths generated by phosphorus and sulfur are permitted to enter the photomultiplier tube, the detection signal is considered to be an indication that samples contain these compounds. As such, the results obtained by direct sampling do not permit precise substance identification; detection only indicates that a sample consists of substances that contain sulfur and/or phosphorus, which may or may not be targeted toxic chemicals⁷¹. The selectivity of these detectors can be improved through the use of a GC column which will increase sample analysis time and the footprint of the detector, but may permit compound identification and a reduction in false positive alarms^{28, 68}.

5.4 Existing Flame Photometric based Field Detectors

Although most of the major instrumentation used for field analysis of CAs is based on IMS, the next most predominant technology is flame photometry¹². The French AP2C monitor and the updated version, AP4C use FPD technology as does the MINICAMS¹².

5.4.1 AP2C

The Proengin SA (Saint Cyr l'Ecole, France) AP2C, shown in Figure 14 (A), is the most notable detector based on flame spectrometry. It is a handheld CWA detector which detects most CWAs, including degraded and homemade agents¹². The AP2C is in service with the French, Swedish, Israeli and Australian military forces, civil defence agencies, and US federal government agencies and fire departments⁷¹. The AP2Ce, seen in Figure 14 (B), is a version of the AP2C which has additional heating systems to enhance the safety and performance of this detector in flammable atmospheres.

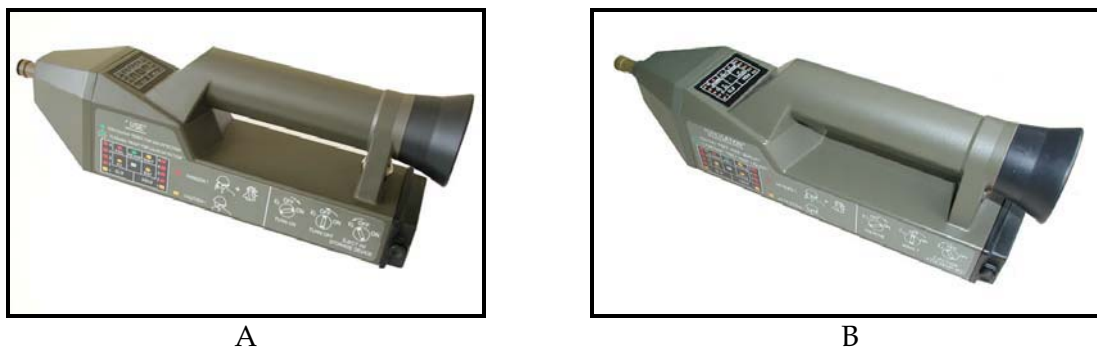

Figure 14: (A) AP2C⁷², (B) AP2Ce⁷³

The AP2C and AP2Ce are sensitive devices that can simultaneously detect both phosphorus and sulfur containing compounds in seconds^{12, 71}. The alarm responds immediately after exposure to CWA, and is terminated soon after the removal of vapour^{71, 74}.

Simultaneous detection of phosphorus and sulfur compounds is achieved through the utilisation of a turning wheel of light filters which allow the detectors to alternatively sense light emitted from phosphorus and sulfur as a sample is burned. The internal light filters are alternated automatically with no need to manually change the detection mode^{12, 74}. When targeted substances are detected the AP2C indicates detection of phosphorus (nerve agents) or sulfur (HD) compounds. When VX is detected both phosphorus and sulfur are indicated¹².

The detected sample concentration is indicated through the use of five rows of light emitting diodes (LED) corresponding to relative concentrations of phosphorus and/or sulfur. Higher detected concentrations cause more LEDs to light. According to the manual, the hazard threshold for unprotected humans is reached as soon as the first red indicator light flashes on⁷⁴.

The detector is easy to operate with a simple on/off turn of the inserted hydrogen cylinder. The detector will then initialise at which point the unit will be pre-heated, the hydrogen circuit purged and the flame ignited. The start up time usually takes approximately two minutes⁷⁴.

The AP2C can also detect liquid surface contamination using the S4PE Surface Sampler Probe accessory shown in Figure 15. If liquid contamination is present, the S4PE, equipped with a sampling tip, is used to wipe the contaminated surface. This is then analysed by the AP2C fitted with the shorter sampling pipe nozzle⁷⁴.



Figure 15: S4PE Surface Sampler Probe⁷⁴

Evaluation of the AP2C by scientists at ECBC, found that the minimum detectable limits of GA and GB were 0.03 and 0.02 mg/m³, respectively, which are an order of magnitude below the IDLH levels of 0.2 mg/m³ (up to half an hour) but above the AEL levels of 0.0001 mg/m³ (up to eight hours)⁷⁴.

The evaluated AP2C units demonstrated rapid, dependable detection, and recovery from agent exposure. They were found to detect agents quickly at all humidity and temperature extremes. The S4PE Surface Sampler Probe accessory was also evaluated and found to produce strong detection signals when the S4PE probe could reach the contamination. However, the probe had difficulties in detecting residual contamination from porous surfaces. Despite this the sampler represents an efficient means to collect and deliver a sample to the instrument for analysis⁷⁴.

5.4.2 AP4C

In 2006 Proengin SA (Saint Cyr l'Ecole, France) released the AP4C, Figure 16, which expands the detection capabilities of the AP2C by incorporating Toxic Industrial Chemicals and Materials (TICs and TIMs) detection. This added capability has produced a device capable of detecting a full spectrum of threats⁷⁵.



Figure 16: AP4C⁷⁶

The AP4C display panel is presented in Figure 17. The first bar graph reveals the presence of phosphorus agents (nerve agents); the second bar graph reveals the presence of nitrogen containing TICs such as hydrogen cyanide and ammonia. The third bar graph reveals the presence of arsenic compounds, such as lewisite and the fourth bar reveals the presence of sulfur compounds (sulfur mustard)⁷⁶. Similar to the AP2C display, the more LEDs lit, the higher the detected concentration.

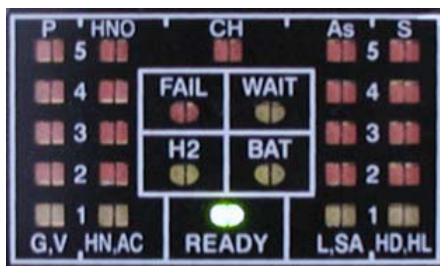

Figure 17: AP4C Display⁷⁶

The AP4C can detect a wide range of chemicals including 49 of the 58 chemicals on NATO's TIC list whilst avoiding common false positives⁷⁵. It also contains the S4PE liquid detection accessory. At this time the AP4C has not been independently evaluated.

5.4.3 MINICAMS

The MINICAMS, pictured in Figure 18, is a compact GC-FPD available from O.I. Analytical (College Station, TX). It is characterised by very low detection limits for the full range of CWAs with a typical cycle time of approximately five minutes. It is claimed that the MINICAMS can detect CWA vapours at sub-AEL concentrations¹².



Figure 18: MINICAMS series 3001⁷⁷

The MINICAMS collects an air sample with a solid adsorbent pre-concentrator or fixed-volume sample loop. The sample contents are then transferred onto a GC column where they are separated⁷⁷. Detection occurs by either FPD, pulsed FPD or Halogen Specific Detector (XSD) and the alarm status is generated if the reported agent concentrations are above the threshold set by the user⁷⁷.

The MINICAMS unit is quite heavy and is not hand-portable. Units consume large amounts of oxygen and clean air. They also suffer from residual false alarms at ultra trace levels due to the limited selectivity of the FPD and the sulfur interference in the phosphorus channel⁶⁹.

5.5 Comparison of FPD Based Detectors

The capabilities of each of the detectors are listed in Table 5 which summarises them against a number of assessment criteria to enable them to be compared.

Table 5: Assessment Criteria for Available FPD

Criteria	AP2C	AP4C	MINICAMS
Detected Agents	G, V and H agents ⁷¹	CWAs and 49 of the 58 chemicals on NATO's TIC list ⁷⁸	Detects and alarms to all chemical warfare agents, precursors, simulant materials, and related industrial chemicals ⁷⁷
Response Times	Less than 2 sec ⁷¹	2 sec ⁷⁸	3-10 minutes ¹⁹
Limits of Detection	GB-10µg/m ³ and HD-400µg/m ³ ⁷¹	G agents-20µg/m ³ and HD-600µg/m ³ . Liquid VX-3µg/cm ² ⁷⁸	GA & GB-0.1µg/m ³ ; GD-0.03µg/m ³ ; VX- 0.01µg/m ³ ; blister agents-3µg/m ³ ⁷⁷
Simultaneous Detection	Yes ⁷⁴	Yes ⁷⁸	
Portability and weight	Handheld, weighs <2.5kg with battery and hydrogen storage device ⁷⁴	Handheld, weighs 2kg with battery and hydrogen storage device ⁷⁸	Portable, weighs 9kg ⁷⁷
Power Requirements	7.3 V Lithium battery pack containing 2 LSH20, liquid cathode and lithium thionyl chloride batteries ⁷⁴	Battery, external power supply of rechargeable battery ⁷⁸	110 (+/-10%) VAC 50/60 Hz or 600 watts ⁷⁷ .
Operational Life	12 hours ⁷⁴	Dependent on power supply	
Operational Temperature Range (°C)	-32 to +55 ⁷²	-31 to +50 ⁷⁸	0 to +40 ⁷⁷

6. Infra-Red (IR) Spectroscopy

IR is employed in several point and standoff CA detectors. For field applications IR-based detectors are used to determine whether a sample contains targeted chemicals rather than being used to identify them^{12, 67}. In IR spectroscopy, IR radiation is passed through a sample and some of this radiation is absorbed whilst some is transmitted. The result is the production of a spectrum which represents the molecular absorption or transmission, creating a unique molecular fingerprint of the sample⁷⁹.

IR instruments measure the amount of light absorbed at a specific wavelength to look for a characteristic chemical group, such as the phosphorus-oxygen bond of nerve agents^{12, 22}. The intensity of this IR absorption is proportional to the concentration of the targeted chemical¹².

The IR region of the electromagnetic spectrum ranges from 0.78 to 1000 microns (µm)²² and can be further subdivided into the near, mid and far IR regions which range from 0.78 µm to 2.5 µm (or wave numbers 12800 – 4000 cm⁻¹), 2.5 µm to 50 µm (4000 – 200 cm⁻¹) and 50 µm to 1000 µm (200 – 10 cm⁻¹), respectively. The most common wavelengths for detection

applications occur in the mid IR region and range between 2.5 μm and 15 μm (4000 - 670 cm^{-1})^{12, 15}. The characteristic wavelengths of GA, GB and HD have been determined to be 9.7, 9.9 and 13.9 μm , respectively⁸⁰.

Since CWAs and many TICs absorb IR of certain characteristic wavelengths, they can be, at least theoretically, detected using IR detectors. The selectivity of these instruments can be controlled by careful selection of wavelengths for each of the targeted chemicals, and to further enhance selectivity a sample may be exposed to IR radiation of several characteristic wavelengths¹².

6.1 IR Technology

A sample is drawn into, or continuously through, a sample cell of fixed dimensions. IR radiation enters the sample cell through an IR-transparent window which is set perpendicular to the radiation path. The window and sample cell are orientated to permit maximum IR radiation to pass through the cell. The radiation can reach the absorption photometer in either a single pass, or in multiple passes via the use of properly aligned mirrors which reflect the IR beam back and forth through the sample multiple times. This can increase the effective path length to a maximum, which subsequently results in the highest sensitivity being achieved¹². IR absorption is then detected by either an IR transducer or via a photoacoustic method. The most common transducers include thermal, piezoelectric and photo-conducting transducers. They act by changing the received IR signal to an electrical signal which can then be processed. Photoacoustic methods, however transform electromagnetic radiation into acoustic waves¹².

At present there are several different detection techniques that utilise IR spectroscopy. They include photoacoustic IR spectroscopy, filter-based IR spectroscopy, passive IR detection, including forward-looking IR spectroscopy (FLIR), and Fourier Transform IR spectroscopy (FTIR)⁶⁷.

6.1.1 Photoacoustic IR spectroscopy

Photoacoustic IR spectroscopy is a highly selective technique that is used to identify CA vapours and is commonly utilised in point detectors⁶⁷.

The operating principle of photoacoustic spectroscopy can be seen in Figure 19. Firstly, the IR beam (left side of Figure 19), which is either chopped or pulsed to achieve the desired frequency, passes through an optical filter and enters the sample cell via an optical window. The radiation is absorbed by the sample, generating heat and pressure variations, which correspond to the chopper frequency and create an acoustic wave which can be detected by microphones. This acoustic signal is translated into an electrical signal by either a sensitive microphone, pressure sensor or a piezoelectric sensor. The signal then undergoes further processing. The magnitude of the pressure generated by the expanding gas is proportional to the concentration of the IR-absorbing substrate^{12, 67, 81}.

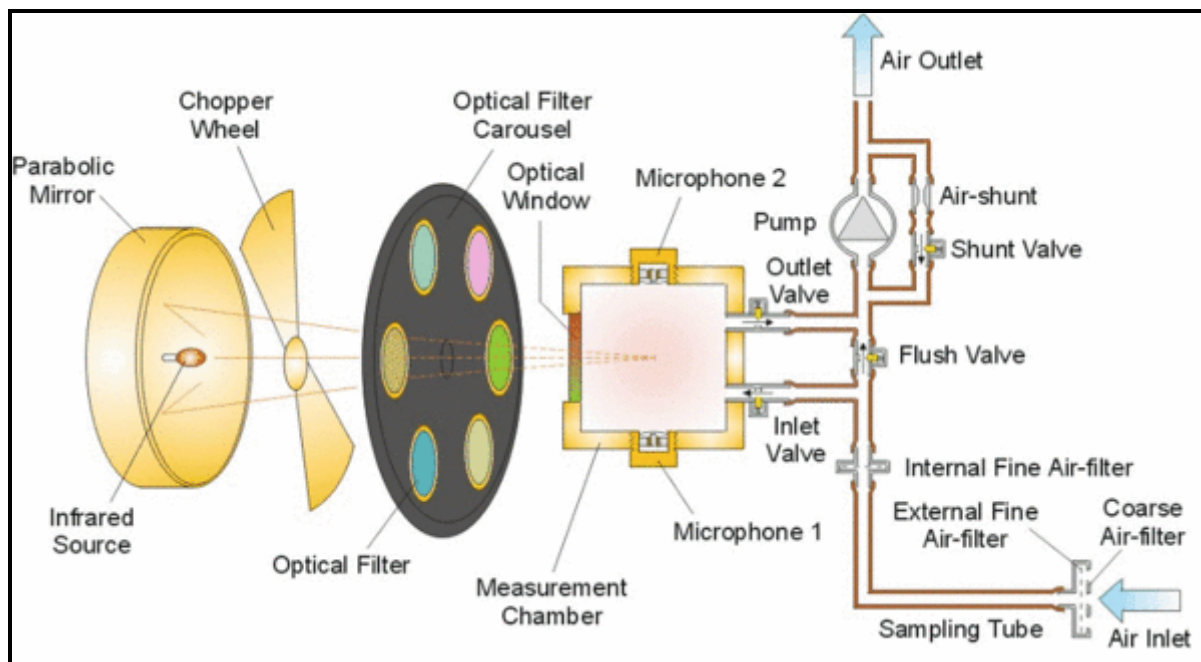

Figure 19: Schematic of photoacoustic spectroscopy⁸¹

The selectivity of this technique is based on the number of wavelengths transmitted through the sample. As more wavelengths are passed, the chance of contaminants causing false alarms decreases. However, these devices are sensitive to environmental variables such as external vibrations but, like IMS, if they are calibrated in the operating environment detection should be accurate⁶⁷. Additionally, absorption, which is proportional to the concentration, is measured directly, not relative to the background, which provides increased detection accuracy⁸¹.

6.1.2 Filter IR spectroscopy

Filter IR detectors act by 'filtering' the wavelength so that only the desired IR wavelength interacts with the sample¹². The technique is based on a series of lenses and mirrors that directs a narrow band-pass IR beam down a pre-selected path and through the sample. The amount of energy absorbed by the sample is measured and stored in memory. The sample is then analysed at as many as four additional wavelengths³.

The technique requires vapour to be drawn into the sample cell by an internal pump so that analysis can begin. The sample is irradiated by an IR beam through a series of filters, which are used to direct the IR beam along a predetermined path⁶⁷. If the sample contains the targeted substance a transducer detects it in the intensity of the exciting beam¹². Therefore, this technique compares the amount of energy absorbed by the sample at several different wavelengths of IR light and can be used to determine concentrations of each vapour component in a sample mixture which can then be used to compile trends and subsequently identify the vapour⁶⁷.

6.1.3 Passive infrared detection

Passive IR detection techniques include FLIR and FTIR spectroscopy and are commonly used in stand-off detection devices that simply alarm when a CA cloud is detected⁶⁷. FLIR and FTIR both depend on the collection of IR information, however the difference between the techniques is related to the way in which information is processed⁶⁷.

FLIR usually refers to a camera that takes pictures using the IR portion of the electromagnetic spectrum. Hence FLIR spectrometers detect thermal energy and create a 'picture'. FTIR-based detectors, on the other hand, are more complicated in that they scan the entire IR wavelength, by way of an interferometer, for both chemical identification and concentration determination¹². The interferometer produces a unique type of signal which has all the IR frequencies 'encoded' into it, therefore, the signal can be measured very quickly⁷⁹.

The interferometer, shown in Figure 20, is composed of a beam splitter, fixed mirror and moving mirror. The beam splitter takes the incoming IR beam and divides it into two optical beams, which are reflected off the mirrors and then recombined before reaching the IR transducer^{12, 79}. Due to the path that one beam travels being of a fixed length and the other path constantly changing as its mirror moves, the signal which exits the interferometer is the result of these two beams 'interfering' with each other. Thus, the resulting signal is referred to as an interferogram, an example of which is shown in Figure 21. Therefore, as the interferogram is measured, all IR wavelength frequencies are being measured simultaneously⁷⁹. As the resultant interferogram signal can not be interpreted directly the signals are manipulated via a mathematical technique called Fourier transformation which enhances the signal to noise ratio of the spectra taken^{15, 79}.

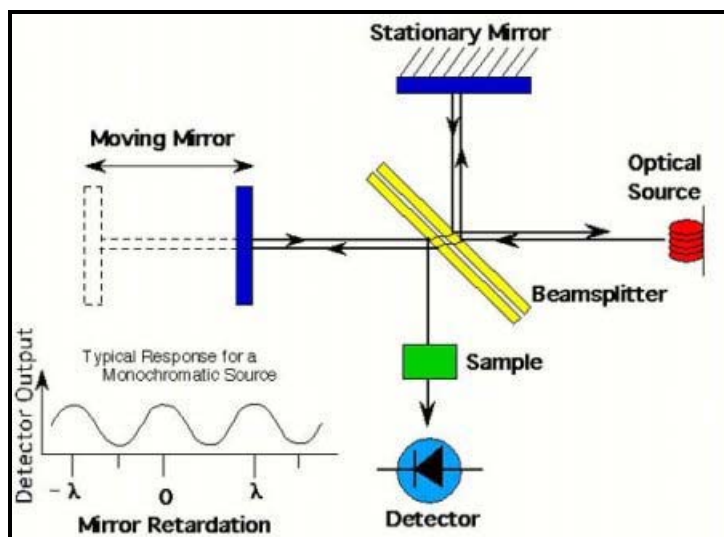

Figure 20: The interferometer⁸²

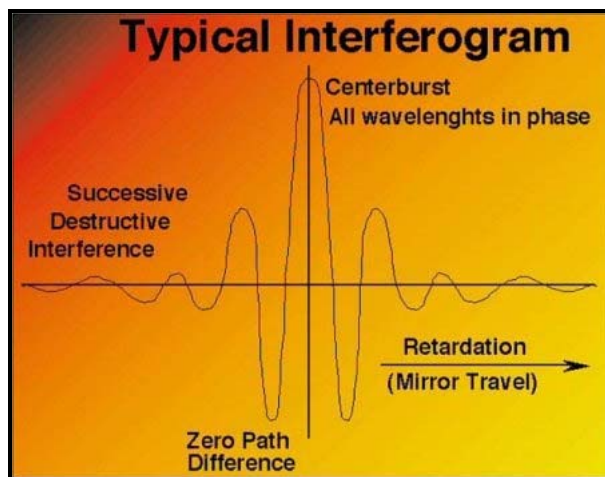

Figure 21: Typical Interferogram⁸²

6.1.4 Differential absorption light detection and ranging

Differential absorption light detection and ranging is an IR technology mainly used to track CA clouds that have already been identified⁶⁷. It operates by transmitting two laser pulses into the distance and then detecting the reflected IR. One of the pulses is at a frequency known to be absorbed by the CA whilst the other is not absorbed. The difference in the intensity of the return signal is used to determine the concentration of CA in the cloud, while the time of return is used to determine the distance from the observers. This technique is also subject to environmental noise but has been used effectively to track CAs⁶⁷.

6.2 Advantages

IR based detectors have the advantage of having reasonably high sensitivity, low LOD and fast detection of vapours. Furthermore, IR is a non-destructive technique which can handle a large sample volume whilst requiring minimal, if any, sample preparation prior to analysis¹².

A sample is introduced into the sample cell, which is closed during the analysis enabling the sample to be subjected to a number of different wavelengths of IR radiation¹². Due to IR not affecting the integrity of the sample, it is highly recommended that the sample be checked using one or more additional characteristic wavelengths if the detected sample produces an alarm at the initial wavelength¹². This is largely due to the fact that various chemicals may contain functional groups that absorb IR at similar wavelengths, and as a result detection determination based on single wavelengths may result in higher false positive and/or negative alarm rates due to reduced discriminatory ability¹².

FTIR has the added advantage of providing a precise measurement method requiring no external calibration. It can increase speed and sensitivity as scans can be collected every second and then can be added together to ratio out the random noise. More importantly FTIR based detectors are mechanically simple as they only contain one moving part, hence there is very little possibility of mechanical breakdown⁷⁹.

6.3 Disadvantages

Major limitations associated with IR-based detectors are cost, complexity and size of instrumentation²². Environmental conditions may also significantly affect an IR-based detector's performance, for example, relative humidity and changes in sample moisture level may generate false positive absorption responses and interferences which may mask peaks of interest¹². This effect can be reduced by utilising a filter to measure background moisture content¹².

Currently available IR spectrometers offer a limited level of standoff detection, whilst photoacoustic-based IR techniques are very sensitive to vibration and environmental effects and as such their use in handheld detection devices for field operations is limited^{12, 22}.

Furthermore, tested detectors based on IR techniques do not have sufficient sensitivity to detect CWA vapours at IDLH levels. However given the ability of these instruments to reliably identify targeted chemicals, they could become useful tools in assessing incidents where the concentration is above IDLH levels¹².

6.4 Existing IR- based Detectors

Detection devices using IR techniques in field applications include remote and point sample detectors. Remote devices that detect IR radiation changes in the background include the M21 detector and the Joint Service Lightweight Standoff Chemical Agent Detector (JSLSCAD), both of which are used by the US military in field operations¹². The MIRAN SapphIRE Portable Ambient Air Analyser is a portable filter- based IR instrument, whilst the AN/KAS-1 and AN/KAS-1A Chemical Warfare Directional Detectors are FLIR based. The TravelIR HCl, HazMat ID and IlluminatIR all employ IR spectroscopy.

6.4.1 M21 Remote Sensing Chemical Agent Alarm

The M21 Remote Sensing Chemical Agent Alarm (RSCAAL), shown in Figure 22 was manufactured by Intellitec (Deland, Florida) and was the first fielded standoff chemical detection device based on passive IR detection⁶⁷.

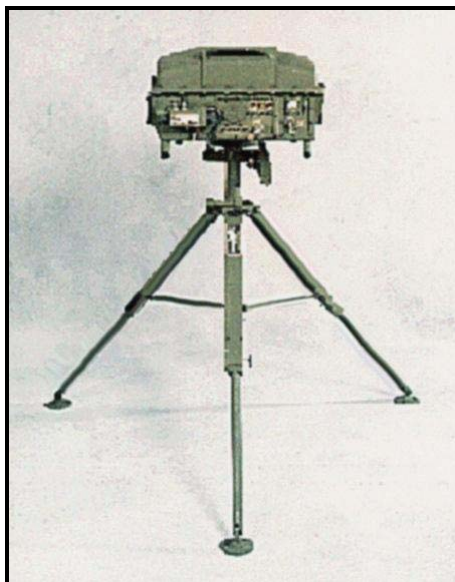

Figure 22: M21 RSCAAL⁸³

This detector operates in the 8-12 μm region of the IR spectrum and has an interferometer that collects absorption or emission spectra from a CA cloud and compares it to a previously collected background spectra⁸³. As a result the M21 RSCAAL is able to detect nerve and blister agent vapour clouds at line of sight distances out to 5 km and along a 60° arc, in seven field-of-view segments^{67, 83}. Detection is therefore based on changes in the IR energy emitted from remote objects, or from clouds formed by an agent⁸³. This became a desired detector due to its ability to automatically scan the surrounding environment and subsequently give early warnings of an attack thus allowing commanders to identify and manoeuvre around contaminated areas^{83, 84}.

When the M21 RSCAAL detects a CA, the alarm light illuminates and the horn sounds. Additionally, small field-of-view lights will illuminate to inform the operator in which field-of-view the agent was detected⁸³. If the agent cloud has been tracked whilst moving, it is possible that all field-of-view lights will be illuminated⁸³.

The M21 is two-man portable and can be set up in approximately 10 minutes. It is generally unaffected by low light conditions, however it is limited in that it must be stationary and it can be obstructed by snow, rain and dust clouds⁶⁷. No independent evaluation has been conducted to assess the effectiveness of this detector.

6.4.2 JSLSCAD

The JSLSCAD, pictured in Figure 23, is manufactured by General Dynamics (Falls Church, Virginia). It is a fully automatic passive FTIR system that detects nerve, blister and blood agent vapour clouds by analysing light emitted by the surrounding atmosphere in the 7-14 μm wavelength range^{75, 84}. It then compares the collected IR spectra against a library of known agent spectra to identify a detected agent and then alerts the operator with both audible and visual alarms⁸⁴.

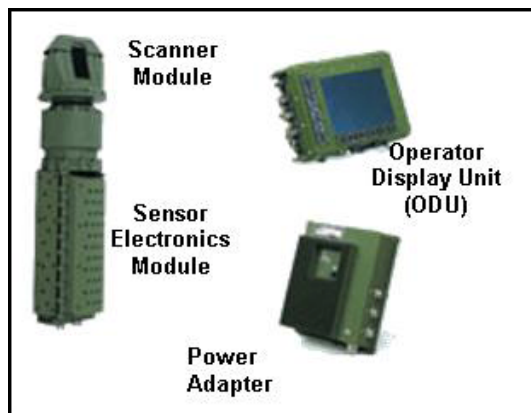

Figure 23: JSLSCAD⁸⁵

This detector was originally designed to address the key limitations of the M21 by providing on-the-move CA detection and type classification⁸⁵. As such, it was the first chemical detection system to supply 360-degree coverage for ground and sea-based platforms at distances of up to 5 km. Furthermore, it can provide an aerial craft detection range of 60-degrees up to 24 km, allowing personnel to avoid contaminated areas or alerting them to don protective masks and clothing^{75, 84, 85}.

To date, this detector has not been evaluated to determine actual LOD or effects of interferences in real situations.

6.4.3 MIRAN SapphIRe Portable Ambient Air Analyser

The MIRAN SapphIRe Portable Ambient Air Analyser, shown in Figure 24, is manufactured by Thermo Electron Corporation (Waltham, MA) and is a man-portable single beam IR spectrophotometer^{80, 86}.



Figure 24: MIRAN SapphIRe Portable Ambient Air Analyser⁸⁶

It can be operated in a multi-gas detection mode that allows it to scan three wavelengths simultaneously⁸⁰. Contaminated air is drawn into the sample cell and scanned across all three IR wavelengths. The intensity of the absorbed IR energy of the air in the sample cell is then displayed on the detector panel in Absorbance Units^{80, 86}. It can operate at different path lengths, which alters the sensitivity. The longest path length available is 12.5 meters, and when utilised maximises the sensitivity of the instrument⁸⁰.

This detector also comes equipped with an interchangeable chemical and external particulate filter. The particulate filter is used to prevent dirt from entering its internal plumbing, whilst the chemical filter is used to zero the detector as well as provide clean air to the instrument in a contaminated environment⁸⁰.

Evaluation of the MIRAN SapphIRe Portable Ambient Air Monitor by scientists at ECBC found that its performance was affected by high humidity. Furthermore the minimum detectable levels of GA, GB and HD were found to be approximately an order of magnitude higher than the IDLH levels and greater than the AEL levels⁸⁰.

During the field tests performed during the evaluation, the detectors' background absorbance readings were found to be significantly higher than the baseline readings in the laboratory⁸⁰. The high background readings negate the usefulness of data obtained for agent detection sensitivity, because there is simply no way to distinguish the absorbance readings of a CA vapour or other contaminants when operated in an unknown environment⁸⁰. Furthermore, the optimum detection wavelength for a compound of interest must be known and manually entered into the memory of the detector to enable detection of a specific substance⁸⁰.

Hence, the evaluation concluded that this detector is not sensitive enough to provide sufficient warning for the safety of users and that in its current configuration cannot be used for CWA detection in the field⁸⁰.

6.4.4 AN/KAS-1/1A Chemical Warfare Directional Detector

The AN/KAS-1/1A Chemical Warfare Directional Detector (CWDD) system, pictured in Figure 25, is a passive IR imaging sensor that can detect and identify nerve agents⁸⁷.

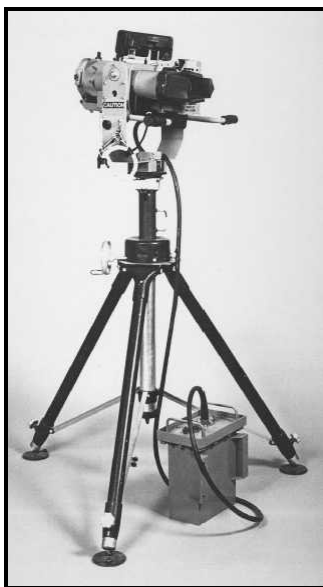

Figure 25: AN/KAS-1/1A CWDD tripod mounted⁸⁸

The AN/KAS-1/1A is a FLIR system used by Navy as a CW advance warning system as well as for surveillance, navigation and search and rescue operations⁸⁸. The CWDD is useful in periods of low-visibility or night area surveillance due to the characteristics of the infrared sensor. A CWDD operator can detect and obtain relative bearings to prominent land features or structures, and can detect small objects floating on the water surface. Also the CWDD can send the sensor's video detections to various locations on the ship, and receive video simulations for operator training⁸⁷.

When used as a CA detector the CWDD uses spectral filters to detect IR radiation emitted by a CA to identify potential CA attacks. CA cloud detection and identification can be accomplished against a sky background for all conditions under which CA attacks may be expected to occur. Detection of CA against a land background is also possible but there is some degradation of effectiveness⁸⁷.

At present there has been no independent evaluation of this device to determine the effects of temperature, relative humidity and interferences on its performance.

6.4.5 TravelIR HCI

In 2001, SensIR Technologies (Danbury, CT) introduced the TravelIR, shown in Figure 26, which was claimed to be the first portable FTIR spectrometer that could rapidly identify an unknown substance in situations where there was clearly a visible threat^{89, 90}.



Figure 26: TravelIR HCI⁹¹

The TravelIR HCI is referred to as an identifier not a detector as it is not fitted with a gas cell for vapour detection and is normally used in conjunction with other traditional detection equipment⁹⁰. Since its introduction, it has been widely used for the identification of a range of unknown materials including CWAs, TICS, explosives, narcotics and other common chemicals⁸⁹.

For normal operation, the TravelIR HCI must firstly be connected to a laptop⁹⁰. The sample is then placed on top of a diamond crystal embedded in a stainless steel disk, called a DuraDisk. The IR beam passes through the crystal, which has a high refractive index, and penetrates the sample producing an IR spectrum which is then compared to an IR spectra of reference compounds in the database library⁹⁰. This process is non-destructive⁹⁰.

There are three variations of the stainless steel DuraDisk available: (i) the Three Reflection disk which provides flexible analysis on solid or liquid samples, (ii) the Single Reflection Diamond Attenuated Total Reflection (ATR) sample disk, shown in Figure 27 which is used for solid samples and (iii) the Nine Reflection disk, also shown in Figure 27, which is used for liquid samples only. The Volatile Cover, as the name implies, is a clear plastic cover that is placed on top of the sample to minimise sample loss during analysis due to high volatility⁹⁰.

The Safety Solid Sampler, shown in Figure 27, allows a solid sample to be safely loaded in a remote location for later analysis by the TravelIR HCI⁹⁰. The pressure arm of this sampling device applies a controlled force to the sample so that better contact is achieved between the sample and the crystal surface which is extremely important for IR analysis⁹⁰.

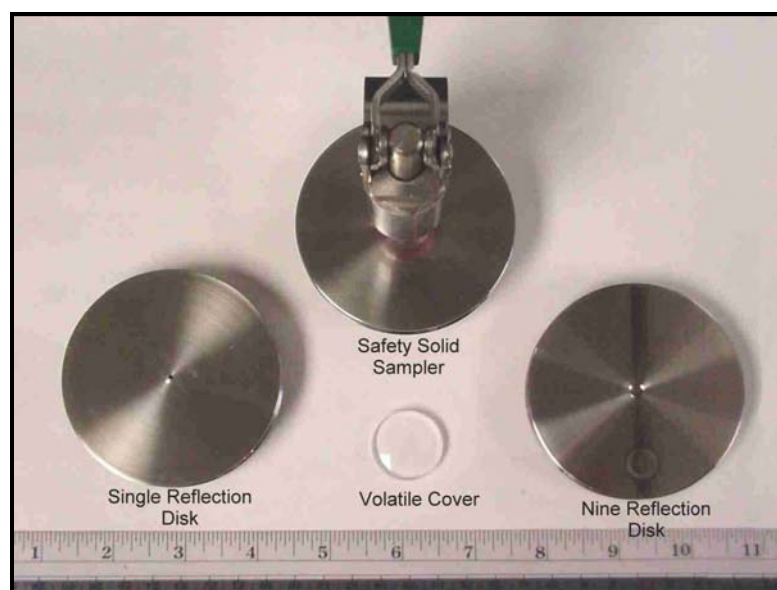

Figure 27: TravelIR HCI sampling accessories⁹⁰

In an evaluation of the TravelIR HCI by scientists at ECBC it was found that this system could identify neat substances readily, reliably and reproducibly. Generally, positive identification results were obtained with concentrations of CWA occurring in the 1-10% range. When the CWA is not dissolved in a liquid the CWA layer is readily identified correctly. However, the identification of a substance in a mixture is more difficult even though the instrument is equipped with software that permits spectra subtractions of the top library matches from the databases. These subtractions can provide the 'proper' identification of compounds in a mixture providing the concentration of the constituent of interest exists in sufficient quantity⁹⁰. As a result the TravelIR HCI should be used in conjunction with other approved CWA detectors⁹⁰.

The results of the evaluation suggested that the implementation of a simplified extraction process may enable the TravelIR to be more useful for the identification of potential CAs in a mixture. However, further investigation, testing and cataloguing of other potential interferents, such as components used for weapons, propellants and naturally occurring environmental compounds was also recommended⁹⁰.

6.4.6 HazMat ID

The HazMat ID, shown in Figure 28, was originally developed in 2003 by SensIR technologies (Danbury, CT) in response to feedback from first responders and the US military regarding the TravelIR. This detector is now widely distributed by Smiths Detection (Watford, UK)⁸⁹.



Figure 28: HazMatID⁹²

The HazMatID is a lightweight, simple and accurate indicator of the presence of any one of a spectrum of harmful CAs that would alert a first responder of a hazard. It is intended to be used in a 'hot zone' by emergency responders, HAZMAT teams, military and other industrial users for analysing chemical, biological, explosive and other substances⁹³. This system is rugged, waterproof, able to be decontaminated, shock resistant and operable in extreme temperatures and humidities⁹³.

It is simple to use and can be used effectively by responders in IPE. To begin analysis, the system is simply turned on; no calibration, consumables or sample preparation are required. A drop, or a few grains of an unknown sample, is placed on a small diamond sensor and the touch screen program will walk the operator through the complete analysis in seconds. If the sample is a mixture, the HazMatID allows the operator to resolve the mixture through an automated 'subtraction' feature in the software⁹⁴.

Another important feature of this system is that the software can be operated wirelessly or remotely, allowing incident command to control the software remotely⁹⁴.

Evaluation of this system conducted by the Fort Lauderdale Hazardous Materials Team supports most claims made by the manufacturers in regards to the system's performance and operability⁹³.

6.4.7 IlluminatIR

The IlluminatIR, shown in Figure 29, is an IR micro-spectrometer developed by SensIR technologies (Danbury, CT) which combines light microscopy and IR spectroscopy⁹⁵. It is a compact, high performance FTIR spectroscopy accessory that interfaces to many of the popular microscope frames resulting in a system that delivers FTIR spectroscopic capability whilst retaining all of the optical/analytical capabilities of the original microscopy system^{95,96}.



Figure 29: *IlluminatIR*⁹⁵

It is simple to use and requires the sample to be centred in the cross-hairs of the microscope⁹⁶. To collect spectral information, the user raises the stage to bring the sample in contact with the diamond surface, then simply presses a button to acquire information and create a report⁹⁶.

To date no evaluation has been performed to determine the IlluminatIR's potential for identifying CA in real world situations.

6.5 Comparison of IR Based Detectors

Each of the aforementioned IR detectors is listed in Table 6. Their individual capabilities have been summarised against a number of assessment criteria to enable them to be compared.

Table 6: Assessment Criteria for Available IR-Based Detectors

Criteria	M21 RSCAAL	JSLSCAD	MIRAN Sapphire	AN/KAS/1-1A	TravelIR HCI	HazMat ID	IlluminatIR
Detected Agents	Nerve, HD and L vapour ²⁷	Nerve (GA,GB,GD,GF) and Blister (HD,L) ⁹⁷	Nerve and blister agents ⁸⁰		Nerve agents and vesicants, TICs, white powders, forensic drug and clandestine lab precursors, explosives & common chemicals ⁹¹	Nerve agents, vesicants, precursors, TICs, forensic drug and clandestine lab precursors, white powders, explosives, common chemicals & pesticides ⁹²	
Response Times	Line of sight dependent ²⁷	Line of sight dependent	Approximately 18 seconds ⁸⁶		Less than 20 seconds ⁹¹	Less than 20 seconds ⁹³	
Limits of Detection	Nerve agents (GA, GB & GD) 90 mg/m ³ ; L 500 mg/m ³ ; HD 2300 mg/m ³ ⁹⁸	Nerve agents 135 mg/m ² ; blister 3300 mg/m ² ; blood (AC) 6600 mg/m ² ; CK 6000 mg/m ² ⁹⁷	GA - 1.30 mg/m ³ ; GB- 0.83 mg/m ³ & HD 2.54 mg/m ³ ⁸⁰		% in isopropyl alcohol: GA 0.625, GB 5.0, VX 0.016, HD 0.25 ⁹⁰		
Simultaneous Detection	Yes ⁹⁸	Yes	Yes	Yes	Yes		
Portability and weight	Two man portable, detector weighs 23.6 kg; & the tripod weighs 6.8 kg ⁹⁹	Vehicle mountable, stand-off. 360° scanner weighs 18.6 kg; 60° scanner weighs 19.5 kg, Power adapter is 6.8 kg & operator display unit weighs 5 kg ⁹⁷	Man portable; Unit weighs approximately 10 kg ⁸⁶	Standoff, weighs < 12.5 kg ⁸⁸	Man-portable, weighing < 12 kg ⁹⁰	Man-portable, weighs < 10.5 kg ⁹⁴	
Power Requirements	Batteries or by standard military generators ⁹⁹	28 Vdc vehicle power or 155 Vac ⁹⁷	Internal, rechargeable Nickel- Cadmium battery or 110 V AC adapters ^{80, 86}	Powered by 115 V AC ⁸⁸	Powered by 110 V outlet, 12 V vehicle power or battery pack ⁹¹	Powered by an internal battery, mains or cigarette lighter ⁹⁴	
Operational Life	277 Hours ⁹⁹					Battery runs from 2 hours and charge time is 3 hours ⁹⁴	
Operational Temperature Range (°C)	-32 to +48 ⁹⁹	-32 to 49 ⁹⁷	5 to 40 ⁸⁰		-7 to 50 ⁹¹	-7 to 50 0 to 100% humidity ⁹⁴	

7. Raman Spectroscopy

Raman Spectroscopy is a light scattering technique based upon the knowledge that when radiation passes through a transparent medium, any chemical species present will scatter a portion of the radiation beam in different directions¹⁵. This technique enables various toxic chemicals including CAs, narcotics and other unidentified potentially hazardous substances to be analysed in glass vials, or plastic bags. This reduces the possibility of evidence corruption, cross contamination and risk of exposure to first responders¹⁰⁰.

Raman Spectroscopy is considered to be a relatively new technique for the field detection of CAs. However, it has been validated for the rapid identification of chemicals, explosives and narcotics¹⁰⁰.

7.1 Raman Spectroscopy Technology

In Raman spectroscopy, a sample is illuminated with a monochromatic laser light and the scattered light is then detected as a function of wavelength. The scattered light results from both elastic collisions, known as Rayleigh scatter, of the photons with the sample molecules and inelastic collisions, known as Raman scatter¹⁰⁰. Rayleigh scatter accounts for the vast majority of the scattered photons, whilst Raman scatter accounts for only a tiny portion (approximately 1 in 10⁷) of the scattered radiation¹⁰¹.

In both Rayleigh and Raman scattering, the incident photon excites an electron into a higher 'virtual' energy level and as the electron decays back to a lower level it emits a scattered photon¹⁰². In Rayleigh scattering the electron decays to the same level from which it started; however in both types of Raman scattering, Stokes and Anti-Stokes Raman scattering, the electron decays to a different level (Figure 30).

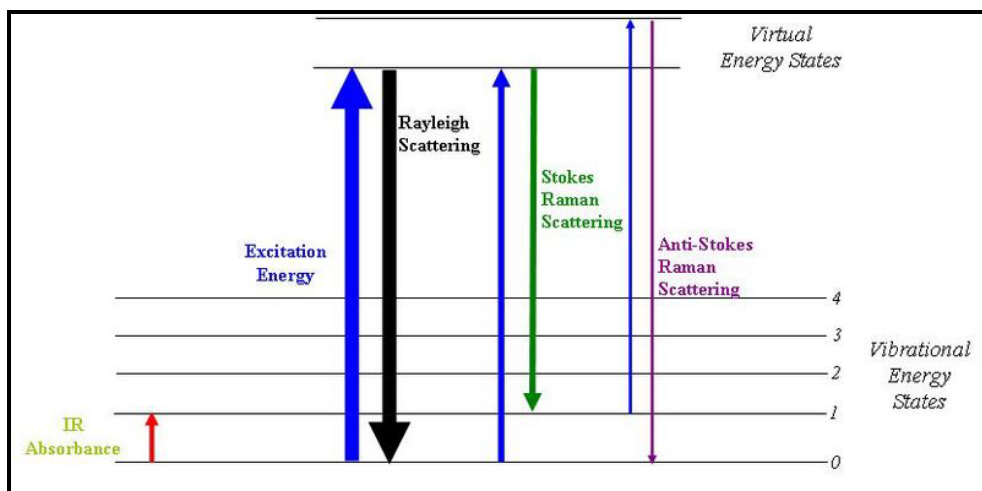

Figure 30: Energy-level diagrams of Rayleigh scattering, Stokes and Anti-Stokes Raman scattering¹⁰¹

Stokes-Raman scattering is the most common form of Raman scattering and is frequently used in spectroscopy, whilst Anti-Stokes Raman scattering only accounts for a small portion of the

Raman scattered photons^{101, 102}. The difference between the scattered radiation and incident beam corresponds to wavelengths in the mid-IR region¹⁵.

Raman spectroscopy uses the molecular light scattering phenomena to selectively detect the presence of CAs by way of spectral fingerprinting¹⁰². A Raman spectrum is a plot of the intensity of Raman scattered radiation as a function of its frequency difference from the incident radiation and is usually expressed in units of wavenumbers (cm^{-1}). This difference is called the Raman Shift, and is independent of the frequency of the incident radiation¹⁰¹.

CAs have a unique signature which can provide a way to remotely detect and identify the presence of an agent in a sample¹⁰².

7.2 Advantages

Raman spectroscopy can be used for the non-destructive evaluation of a CA in a glass container, thereby minimising any exposure hazard to the operator²².

Devices using Raman spectroscopy are able to assess liquids, gases, solids and aerosols, and are not affected by water in either liquid or vapour form. Furthermore, they enjoy negligible variations in signatures or signal strength regardless of surface texture or reflectivity¹⁰².

Raman spectroscopy is a useful tool for chemical analysis as it exhibits high specificity, which is achieved because Raman detects fundamental vibrations. The Raman bands have good signal-to-noise ratio and are non-overlapping¹⁰¹. It also allows aqueous samples to be analysed due to water having a weak and unobtrusive Raman spectrum. Raman is also advantageous in that it requires no sample preparation or contact with the sample and a spectrum can be acquired in a very short time¹⁰¹.

7.3 Disadvantages

Raman can not be used for the identification of agents in munitions, as the technique requires a window through which light can pass²². Also it does not appear to be capable of detecting CWA precursors and degradation products in soil samples but it can be used for air samples¹⁵.

The main disadvantages associated with Raman-based detection include the fact that it is not 100% accurate and can sometimes miss chemicals and produce false negative results. Furthermore, Raman can not be used to differentiate mixtures; for example, if a mixture contained 10% of a dangerous material and 90% safe material, Raman would not be able to detect the dangerous material¹⁰³.

7.4 Existing Raman -Based Field Detectors

The only handheld Raman-based instruments currently available for the detection of CAs are manufactured by Ahura Corporation (Wilmington, MA) and include the FirstDefender and more recently the FirstDefender XL. The ECBC has also been involved in the development of a Raman-based standoff detection system called the Joint Contaminated Surface Detector (JCSD).

7.4.1 FirstDefender

The FirstDefender, Figure 31 (A) and the FirstDefender XL, Figure 31 (B), are Raman based handheld field detectors designed for first responders. The detectors contain a source laser, an optical probe for directing light to the sample and collecting the Raman scatter, and a spectrometer for analysis of the Raman spectrum¹⁰⁰.



Figure 31: (A) Ahura FirstDefender¹⁰⁴, (B) Ahura FirstDefender XL¹⁰⁵

According to the manufacturer, the FirstDefender allows accurate identification of thousands of solids and liquids in the field. They further claim that the capabilities of this detector complement existing fielded technology rather than competing with them. As such it is targeted at identifying thousands of substances, rather than a handful of specific chemicals. It is also said to be able to perform in all environments¹⁰⁵.

The detector is a self-contained and completely waterproof chemical identification system that has a warm-up time of less than one second. It is able to provide a positive identification of an unknown substance in a non-contact manner typically in less than 15 seconds¹⁰⁵. It has three modes of use, two of which are 'point-and-shoot' modes and the third which is an 'in-vial measurement' mode¹⁰⁰.

The first 'point-and-shoot' mode requires the targeting cone (found at the top of the detector) to be placed onto the sample. The metal cone contains the laser beam and maintains the required focal distance to the sample. The second 'point-and-shoot' mode requires the

targeting cone to be removed so that the unit can be held approximately 1.5cm above the sample to limit potential contamination and user exposure. The 'in-vial measurement' mode, as the name implies is a direct measurement of a sample in a vial. A hatch is present above the screen and beneath the logo marked area. When lifted, a hole is present for inserting a standard 4mL test vial. The vial is positioned to allow measurements of both powders and liquids. The vials can then be saved for evidence collection or a confirmatory laboratory test¹⁰⁰.

The capabilities of the FirstDefender were evaluated through testing with both neat CWA and a broad range of agent and interferent mixtures in sealed glass containers by scientists at ECBC. They found that the FirstDefender correctly identified the CA under consideration in 78 of the 88 cases tested. Twenty two of these cases were neat agents and the remaining cases were mixtures of agent and one of the interferents at concentrations of 50% to 1.125% agent by volume. The failures in agent detection were largely at agent concentrations at or below 10% in Windex (window cleaner)¹⁰⁰. During the trial, it was also found that GF exhibited substantial fluorescence, at levels, that field detection of this agent would be very difficult to achieve within reasonable measurement times¹⁰⁰. The other key finding was that the two nitrogen mustards, HN1 and HN3, were moderately fluorescent, although characteristic Raman scatter was observable within reasonable measurement times¹⁰⁰.

To date, no independent evaluation has been performed on the FirstDefenderXL.

7.4.2 JCSD

The JCSD, shown in Figure 32, is currently in use by the US Army and Marine Corps. It uses ultraviolet (UV) laser technology to detect a chemical liquid on the ground. The JCSD can provide real-time detection and identification of CAs and mapping of CA contamination. It is also capable of detection from a distance and can provide on-the-move, near instantaneous detection and identification in operational environments¹⁰⁶.

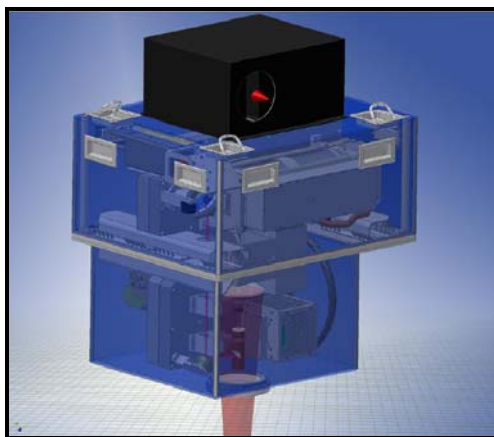

Figure 32: JCSD¹⁰⁶

The JCSD has been designed to be mounted underneath a vehicle where it fires 25 times a second¹⁰⁷. The detector operates by using its laser to hit a chemical causing Raman scattering. A camera and telescope then detect the shift of electrons back to their initial energy state and produce a spectrum characteristic of the chemical¹⁰⁷.

ECBC claim that the JCSD takes approximately 40 seconds to make a detection but depending upon the processing time and the vehicle's travelling speed, the detector can take up to two minutes to sound an alarm¹⁰⁷. Furthermore, because the JCSD is not dependent on surface contact, it is able to identify chemicals in liquid and solid states¹⁰⁷. However, this detector has not been independently evaluated.

Currently the JCSD has been programmed by ECBC scientists to detect and identify 20 CAs, 30 TICs and nine interferences on six surfaces using its on-board library. If an unknown chemical is detected the JCSD is able to record a spectrum and notify the operator to collect a sample for further analysis. After the sample is identified the operator can reprogram the system to give an alarm¹⁰⁷.

7.5 Comparison of Raman- Based Detectors

The capabilities of the three Raman-based CA detectors are listed in Table 7.1 against a number of assessment criteria to enable them to be compared.

Table 7: Assessment Criteria for Available Raman-Based Detectors

Assessment Criteria	Ahura's FirstDefender	Ahura's FirstDefender XL	JCSD
Detected Agents	CAs, toxic chemicals, explosives, white-powders, narcotics, contraband and forensics ¹⁰⁴	CAs, toxic chemicals, white powders, narcotics, contraband and forensics ¹⁰⁵	20 CAs, 30 TICs, 9 interferences ¹⁰⁷
Response Time	Analysis time < 15 secs ¹⁰⁴		Approximately 40 secs
Limits of Detection			
Simultaneous Detection	Yes		
Portability and weight	Hand held, weighs < 1.5kg ¹⁰⁴	Hand held, weighs < 2 kg ¹⁰⁵	
Power Requirements	Rechargeable lithium ion batteries ¹⁰⁰	Rechargeable lithium ion batteries ¹⁰⁰	
Operational Life	5 hours ¹⁰⁴	5 hours ¹⁰⁵	
Operational Temperature Range (°C)	-20 and +40 ¹⁰⁰		

8. Surface Acoustic Wave (SAW)

The introduction of SAW technology into military and civil defence is relatively new and as such it is expected that a number of improvements will take place over the next few years^{28,55}. SAW chemical detectors are able to identify and measure many CAs simultaneously and are relatively inexpensive, making them a popular choice amongst civilian response units⁶⁷.

SAW sensors operate by detecting changes in the properties of acoustic waves as they travel at ultrasonic frequencies in piezoelectric materials¹⁵. The piezoelectric effect occurs when a piezoelectric plate, made of a natural crystal such as quartz, is subjected to a mechanical strain, such as tension or compression, and an electric voltage is generated¹².

8.1 Surface Acoustic Wave Technology

A typical SAW device comprises a piezoelectric crystal plate coated with a chemically selective polymer and two interdigital transducers (IDTs), shown in Figure 33¹². The SAW operates when an alternating voltage is applied to the input transducer generating an alternating mechanical strain (tension or compression) that initiates a SAW that travels along the surface of the substrate before being converted back into an electrical signal by the output transducers¹⁰⁸. Hence the two major processes which contribute to the detection of CAs with a SAW device are the generation and change of surface waves on a piezoelectric crystal plate and the sorption/desorption of chemicals on the surface¹².

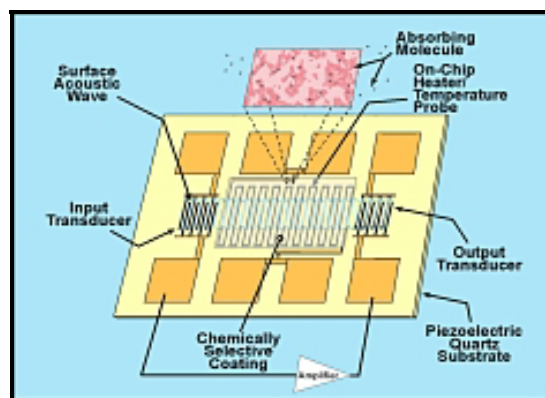

Figure 33: Schematic of a SAW Device¹⁰⁸

For these SAW devices to selectively detect targeted chemicals, the propagation path of the acoustic wave is coated with a selected polymer substance¹². This is because the piezoelectric crystal itself does not have the ability to attract and sorb target chemicals¹². A thin layer of polymer substrate is normally chosen as polymers have many free, active sorption sites that can effectively sorb the incoming chemical molecules. Sorption is thus defined as the simultaneous adsorption and absorption of a molecule by the substrate¹².

When a sample vapour enters the SAW detector, molecules in the vapour come in contact with the polymer surface at a certain rate, depending upon the vapour flow. When a CA

molecule hits the surface, it will be either bonded to the active sorption sites on the surface of the polymer or deflected by the surface, as shown in Figure 34¹². An important requirement for the polymer coating is that the sorption of targeted chemicals must be totally reversible after an analysis¹².

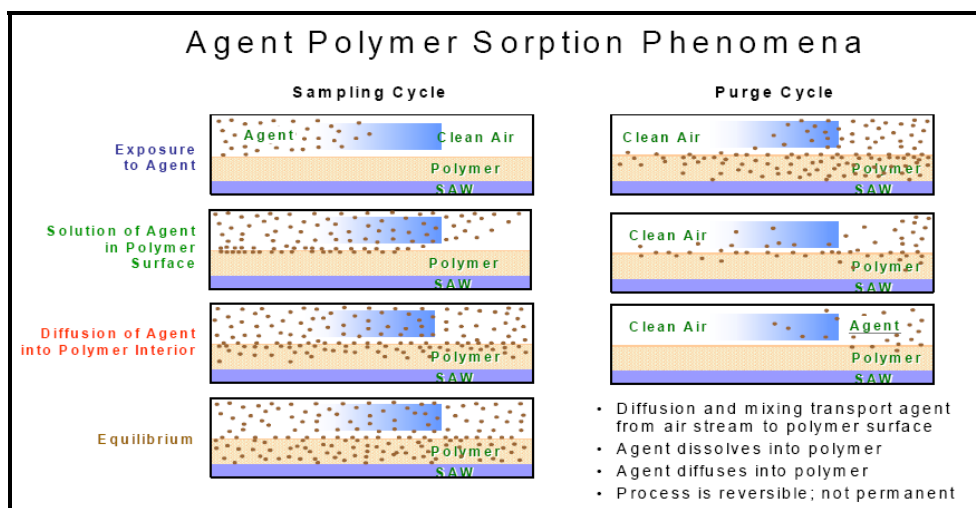

Figure 34: SAW Sensor Absorption and Desorption of Vapour Molecules¹⁰⁹

SAW detection is based on the solubility interaction between a CA and the polymer surface¹¹⁰. The polymer films are normally chosen so that each will have a different chemical affinity for one of a variety of organic chemical classes such as hydrocarbon, alcohol, ketone, oxygenated, chlorinated and nitrogenated^{22, 111}.

In general, a sample is introduced into a SAW detector via a pre-concentrator, which adsorbs the test vapours for a given period of time and is then heated to release the vapours over a much shorter time span, thereby increasing the effective concentration of the vapour^{22, 111}. The chemicals in the vapour then enter the SAW array and any sorption by the polymer on the surface of the piezoelectric substrate will change the surface wave propagation on the substrate. Thus, wave frequency change and its attenuation are used to determine the amount of substrate deposited on the device. The signals are processed to identify chemicals sorbed from the sample, and by assuming that sorption equilibrium is reached, the concentration of the chemical in the vapour can be determined¹². Following this the detector goes through a purge cycle, shown in Figure 34, whereby the sensors are heated to ensure the sorbed chemicals are effectively released¹².

By using an array of SAW sensors where each different sensor is coated with a polymer intended for selective sorption of a targeted group of chemicals, a specific response pattern or fingerprint that is unique to the class of agent can be generated. This can facilitate identification of the vapour and rejection of potential interferences^{12, 15, 22, 110}.

A typical SAW detector may have three or more sensors, one of which is usually isolated from the sample flow path for compensation of temperature-induced effects¹².

8.2 Advantages

SAW devices with good detection sensitivity can be manufactured at relatively low cost. They respond rapidly to chemicals deposited on their surface and can be miniaturised easily¹². They use an effective and reliable method for detection of low levels of nerve and blister agents and in theory, are not typically subject to false alarms¹¹¹. Through proper design, SAW detectors can be used to effectively detect CAs in a variety of environmental conditions¹¹¹.

8.3 Disadvantages

The sensitivity and response of a SAW-based device is limited by its polymer's absorption ability²². Theoretically, a SAW device could have a low false alarm rate however, it is not possible for a polymer to sorb only one chemical, and in reality, a single polymer will usually sorb several different chemicals from a gas mixture thus leading to potential false alarms¹². However, this may be overcome by setting up an array of sensors coated with polymers intended for the selective sorption of differing groups of chemicals.

The performance of SAW devices can also be affected by temperature and humidity variations and SAW devices are often susceptible to damage from some highly reactive vapours^{22, 111}. The polymer coatings can physically change when a device is exposed to conditions outside the operating temperature range and once the coating has physically changed, a sensor's ability to effectively detect the gas of interest is compromised¹¹¹. The different polymer coatings used in SAW devices have varying sensitivities to humidity, however the pre-concentrator can dramatically reduce the effects of humidity on a detector's performance¹¹¹.

8.4 Existing SAW- Based Field Detectors

There are a number of detectors currently fielded that are based on SAW technology including the HAZMATCAD, ChemSentry 150C, CW Sentry Plus, SAW MINICAD mk II and the Joint Chemical Agent Detector (JCAD).

8.4.1 HAZMATCAD

HAZMATCAD, pictured in Figure 35, is a CA detector and alarm which has been manufactured by Microsensor Systems, Inc. It employs an array of three SAW sensors in a handheld portable Chemical Agent Detector (CAD) instrument¹¹⁰. It incorporates a pre-concentrator sorbent material and selective polymer coatings, and utilises thermal desorption profiling and pattern recognition software to separate the responses generated by CAs from those generated by other gases and vapours¹¹⁰.



Figure 35: HAZMATCAD¹¹²

The detector has two modes of operation, a 'fast' mode and a 'high sensitivity' mode which operate on a 20 second and 120 second analysis cycle, respectively. Therefore every 20 or 120 seconds, depending on the operational mode, the HAZMATCAD reports an updated analysis to the user¹¹⁰.

When turned on, a device automatically performs a self-diagnostic check, goes through a purge cycle and then begins analysing for a CA¹¹⁰. No daily instrument calibration is required as a detector's performance can be quickly verified by exposure to a confidence sample¹¹⁰.

The detector is capable of simultaneously detecting nerve and blister agents with detection being identified by corresponding 'G' or 'H' visible and audible alarms at low, medium or high concentration levels. The low alarm occurs when the SAW signals reach the preset alarm threshold value, the medium alarm occurs when the SAW signals are two times higher than the alarm threshold value and the high alarms occur when the SAW signals are five times higher than the alarm threshold signal¹¹⁰.

Evaluation of the HAZMATCAD by scientists at ECBC showed that the minimum detectable levels (MDLs) for HD, GA and GB were well above the IDLH and AEL levels¹¹⁰. It was also determined that temperature extremes affected performance; for example, it was discovered that at low temperatures (0°C) the detector required much longer recovery times and more importantly it would not alarm to GA in 'fast' mode due to the inability of the sensor array heater to maintain the required operating temperature¹¹⁰. At high temperatures, on the other hand, the collection efficiency of the pre-concentrator was found to be greatly reduced, leading to higher concentration levels being required for detection¹¹⁰.

The evaluation also showed that this detector performed exceptionally well when tested against a number of interferences. It produced only one false positive which was to a 1% concentration of Windex Glass Cleaner, where it alarmed as 'Low G' after 102 seconds of exposure¹¹⁰.

The evaluation demonstrated that overall the HAZMATCAD performed better than any of the other detectors that had been evaluated by ECBC, with most of the operational deficiencies, such as inconsistent response, erratic behaviours, and frequent malfunctions being easily overcome¹¹⁰.

8.4.2 JCAD and JCAD ChemSentry 150C

The JCAD, Figure 36 (A), has been developed by a company called BAE Systems (London, UK) and is a commercially available portable automated SAW-based detector designed to be used by every department of the military⁶⁷. To date it has been adopted by the Fire Defence teams and the Air-Self-Defence Force in Japan²⁸.

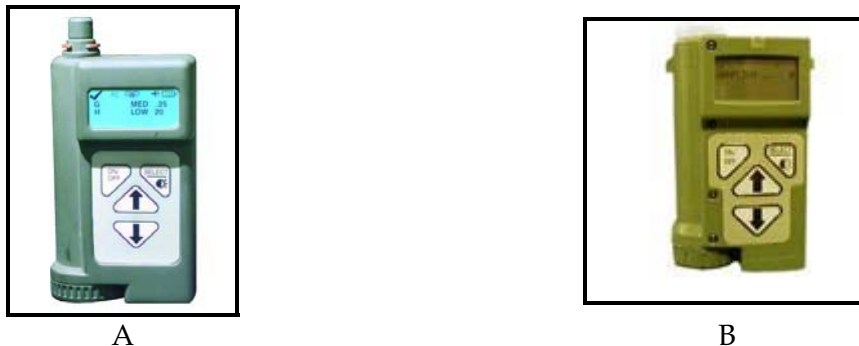

Figure 36: (A) JCAD¹¹³, (B) ChemSentry 150C¹¹⁴

The JCAD ChemSentry 150C, pictured in Figure 36 (B), is the commercial version of JCAD which is now in production. It uses the same design and offers the same features and performance of JCAD to civilian and military users world-wide. It is capable of simultaneously detecting blood, blister and nerve agent chemical vapours and also accumulates, reports and stores chemical events in the on-board memory¹¹⁴.

Both JCAD detectors employ SAW technology and contain sensor arrays of 10 SAW crystals²⁸. Weighing less than 1 kg, the detectors are small enough to be handheld and used as personal protection detectors; however they are also capable of being installed and networked in vehicles, aircraft, ships and buildings^{67, 114}.

The JCAD automatically and simultaneously detects, identifies and quantifies chemical vapours by class (nerve, blister, blood and/or TIC) and specific agent (GA, GB, GD, HD etc)^{12, 28}. Further, in the event of CA detection, it provides immediate operator feedback by way of a LCD, a LED and an audible alarm¹¹³.

For detection of low levels of a specific CA the JCAD utilises a pre-concentrator which is a quick release, peripheral attachment that uses an adsorbent to collect low level CAs for 20 minutes^{67, 113}. During the collection period, the detector unit continues to sample the ambient air for potential 'high' CA concentrations that may require an immediate response. At the end of the collection period, the pre-concentrator pump is reversed and the adsorbent is heated to enable the CA vapour to be released and subsequently drawn through the detector unit where it is detected and identified^{67, 113}.

To date no independent evaluation has been performed on the JCAD to establish its MDLs and to determine the effect of temperature, humidity and interferences on its detection capabilities.

8.4.3 CW Sentry Plus

The CW Sentry Plus, shown in Figure 37, is a permanently installed multi-gas analyser that detects and classifies both CAs and TICs. This device is manufactured by Arrow-Tech, Inc. (West Rolla, North Dakota) and is based on a combination of SAW arrays and electrochemical cells¹¹⁵.



Figure 37: CW Sentry Plus¹¹⁵

This unit is designed to be fixed to a site where it can complete three analysis cycles per minute. It uses a redundant sampling pump to draw a sample from up to three meters away¹¹⁶.

It requires no regular maintenance or calibrations as it has an internal check source and self diagnostics which are used to verify its performance¹¹⁶.

There has been no evaluation conducted on this detector as yet and there is no available information regarding its operation.

8.4.4 SAW MINICAD mk II

The SAW MINICAD mk II, shown in Figure 38, is a portable, lightweight, battery operated and commercially available SAW array detector manufactured by MSA (Pittsburgh, PA). It can be used remotely to define areas of contamination or employed as an active detector⁶⁷.



Figure 38: SAW MiniCAD mk II¹¹⁷

It simultaneously detects nerve and blister agents and reports them via an alarm¹¹⁸. A red LED will flash if 'G' or 'H' is detected and if a high concentration is detected a red 'HI LEVEL' light will also flash¹¹⁸. Due to the SAW technology employed by this detector it is highly selective to these agents and is extremely resistant to false alarms^{117, 119}.

It uses power supplied from either standard off-the-shelf lithium batteries or a rechargeable battery pack¹¹⁷. It requires no daily calibration, and performance is verified simply by exposure to the supplied confidence sample¹¹⁸.

The instrument is relatively simple to operate. Once turned on it performs a self-diagnostic check, purges itself and then automatically begins analysing for CAs¹¹⁸. During analysis, the instrument draws a sample through a pre-concentrator using a diaphragm pump. The concentrated vapour is then thermally desorbed and pulled into the detection unit where it is analysed. A microcomputer then analyses the sensors' responses to determine when to alarm¹¹⁸.

The manufacturers claim that the detector continuously runs through 60 second analysis cycles, which includes 40 second sampling and 20 seconds desorption¹¹⁸. However during its evaluation by scientists at ECBC it was found that none of the units tested responded within 60 seconds; they were all found to require longer response times. Longer response times were thought to be due to that fact that this detector does not give any indication as to which cycle it is currently operating. Therefore the operators do not know if the detector is in the sampling or desorption cycle¹¹⁸. Hence, if the agent challenge was introduced at any time other than at the beginning of the sampling cycle, it would have prevented a full sample analysis for that cycle¹¹⁸. The evaluations also found that the MDLs for GA, GB or HD for the SAW miniCAD mk II were greater than the IDLH or AEL¹¹⁸.

High temperature (40°C) also affected the instruments' detection capability as it appeared to have defeated the proper functioning of the sample pre-concentrator. Cold temperature, on the other hand, was found to affect the detectors' ability to recover after agent exposure. During analysis at ambient temperatures the detectors typically required several cycles or several minutes to clear down; however when operated in cold temperatures the detector required up to 25 minutes to recover from agent exposure. The units required longer recovery times as testing progressed¹¹⁸.

With reference to interferences, the SAW MiniCAD mk II was found to suffer from no false alarms. However, the detectors did exhibit some residual effects to the field exposure tests. Following the field trials, the detectors were again subjected to HD and it was observed that the detectors took double the amount of time to respond to the same agent concentrations compared with the response times from the pre-field tests. Also one of the units tested failed to respond to GA or GB after the field tests¹¹⁸.

The usefulness of this detector as a viable warning device was found to be limited by the problematic behaviours observed. The evaluation was plagued by the unpredictable behaviour observed among the units and although there were no false alarms recorded during the interference tests, the units were found to perform sluggishly when responding to their simulant checks after the field tests which clearly indicates a lack of sensitivity¹¹⁸.

8.5 Comparison of SAW- Based Detectors

The capabilities of the SAW-based CA detectors are listed in Table 8. They have been compared against each other for a number of assessment criteria, thus enabling the easy comparison of each detector.

Table 8: Assessment Criteria for Available SAW-Based Detectors

Criteria	HAZMATCAD	JCAD ChemSentry	CW Sentry Plus	SAW MINICAD mk II
Detected Agents	Nerve - GA, GB, GD, GF and VX Blister - HD, HN3 Blood - AC, CK Choking - CG ¹¹² TICs: Hydride gases - Arsine, Diborane, Silane, Halogen gases- Chlorine, Fluorine, Bromine Acidic gases Sulfur dioxide ¹¹²	Nerve (GA, GB, GD, GF and VX), blister (HD, HN3 and L), and blood (AC and CK) agents ¹¹³	Nerve - VX, GA, GB, GD and GF. Blister - HD, HN3 Blood - AC Choking - CG TICs: Hydride gases - Arsine, Diborane, Silane, Halogen gases- Chlorine, Fluorine, Bromine Acidic gases Sulfur dioxide ¹¹⁵	GA, GB, GD and HD ¹¹⁹
Response Times	Responds between 20 to 120 sec ¹¹²	Responds between 10 to 90 sec, depending on agent concentration ¹²⁰	Response time 20 sec ¹¹⁵	Analysis time 60 sec ¹¹⁹
Limits of Detection	GD and HD in High Sensitivity Mode at close to IDLH limits in up to 4 minutes ⁵⁵	GA: 100mg/m ³ ; GB: 30mg/m ³ and GD: 50mg/m ³ within 12-13 sec ²⁸ . HD: 40mg/m ³ within 8 sec; Lewisite: 300-10000mg/m ³ within 13 sec; HCN: 30mg/m ³ CNCl:1000 mg/m ³ within 2 minutes ²⁸	Nerve - 0.04-0.16 ppm Blister - 0.14 ppm Blood - 5 ppm Choking - 0.3 ppm Hydride - 0.5 ppm Halogen - 10 ppm ¹¹⁵	GA: 0.2mg/m ³ ; GB: 0.5mg/m ³ ; GD: 0.1mg/m ³ ; HD: 1mg/m ³ ¹¹⁹
Simultaneous Detection	Yes.	Yes.	Yes.	Yes.
Portability and weight	0.63kg ⁵⁵	Handheld, weighing < 1 kg ¹¹³	Designed to be permanently installed, weighs 18.2 kg ¹¹⁵	Light, handheld weighing 0.5 kg, including batteries ¹¹⁹
Power Requirements	Rechargeable Li-ion batteries ¹¹²	Will operate on either platform power or an internal battery (BA-5800) ¹¹³ .		Lithium cells ¹¹⁹
Operational Life	8 hrs in fast mode and 12 hrs in sensitive mode ¹¹²	Battery life is greater than 18 hrs on the primary battery or approximately 12 hrs on a rechargeable battery ¹¹³		5 year shelf life ¹¹⁹ Mission life of 6-8 hrs ¹¹⁹
Operational Temperature Range (°C)	-10 to 50 ¹¹²	-32 to 49 ^{113, 114, 120}	-20°C to 50 ¹¹⁵	5°C to 40°C ¹¹⁹

9. Colorimetric

Colorimetric detection is a wet chemistry technique formulated to indicate the presence of a CA by a chemical reaction that causes a colour change when agents come into contact with certain solutions or substrates³. Colorimetric detectors have been employed by the military for a number of years as they are the fastest, cheapest, lightest and easiest type of detector to use in the field²².

The most common colorimetric detectors come in the form of detection tubes, papers or tickets, each of which can detect nerve, blister and blood agents³.

9.1 Colorimetric Technology

Colorimetric technology is based upon specific chemical reactions that occur when the CAs interact with certain substrates and solutions²³. Colorimetric detectors are commonly made with sorbent substrates, such as paper and paper tickets, to which a reagent has been applied¹². When the targeted chemical comes into contact with the substrate, it will react with the reagent to produce a distinctive colour change which can be visually detected¹². The concentration of the targeted chemical in the sample can also be estimated based on the intensity of the developed colour over the exposure time¹².

These detectors are considered to be quite specific and usually come in the form of kits. The kits are quite complex as they include multiple tests for specific agents or families of agents¹⁵.

9.2 Advantages

The major advantages of colorimetric detectors are that they are easy to use, low-cost and provide relatively fast responses¹². Also because most colorimetric detectors are designed to be selective, that is, the selected reagent will only react with a specific class of chemical compound to produce a colour change, they suffer from low false alarm rates¹².

9.3 Disadvantages

Although selectivity is one of the major advantages of these detectors, it can also be one of the major disadvantages. Due to their selectivity, many different colorimetric detectors would be required in field applications¹². However to overcome this problem, some companies have produced kits which incorporate several different tests for detecting specific classes of compounds¹².

The colour changes produced by colorimetric detectors rely on visual signal processing which may also be problematic. Firstly, each person has a slightly different colour perception and some people may suffer from some degree of colour blindness thus impairing their ability to observe certain colour changes¹². It is also difficult to observe colour in dim or bright light which may limit the effectiveness of colorimetric detection devices¹².

Detection may also become unreliable if any moisture is lost or absorbed by the sensor spots during use or storage¹².

9.4 Existing Colorimetric Field Detectors

The most common colorimetric-based detectors are paper, tubes and detection kits¹². Detector papers are generally used for testing suspect droplets on a surface, whereas detector tubes are used for testing gaseous or vaporous CA³. Detection kits usually contain a combination of tubes and papers for detection of multiple compounds.

9.4.1 Chemical Detector Paper

Detector paper is one of the least sophisticated and least expensive techniques for CA detection, yet it provides a very sensitive way of detecting liquids and aerosols^{3, 67}.

Normally detection paper contains two dyes and a pH indicator which are integrated into the cellulose fibres of the paper. When a drop of CA is absorbed by the paper, it dissolves one of the dyes, producing a visible colour change in the paper^{3, 67, 121}. The colour will change according to the type of agent present, for example HD dissolves the red dye, nerve agents dissolve the yellow dye and VX dissolves the yellow dye as it is a nerve agent but also causes the pH indicator to turn blue thus creating a green-black colour change^{3, 121}.

Chemical detection paper has the disadvantage that it lacks specificity and can result in false positives as it is known to react with common chemicals such as brake fluid, antifreeze, and insect repellent. False readings are especially undesirable in civilian situations because they may lead to mass panic. Therefore, it is strongly advised that chemical detection paper always be used in conjunction with another detector to increase accuracy^{3, 67, 121}.

The detection papers currently in service by the US Military are M8, M9 and 3-way detection paper²².

9.4.1.1 M8 Detection Paper

M8 detection paper, pictured in Figure 39, detects and differentiates liquid 'V', 'G' and 'H' agents. The beige paper contains two dyes and an acid-base (pH) indicator which changes to yellow when in contact with 'G' agents, green when in contact with liquid VX and red when in contact with liquid HD²². The colour change typically occurs within 30 seconds of exposure⁶⁷.

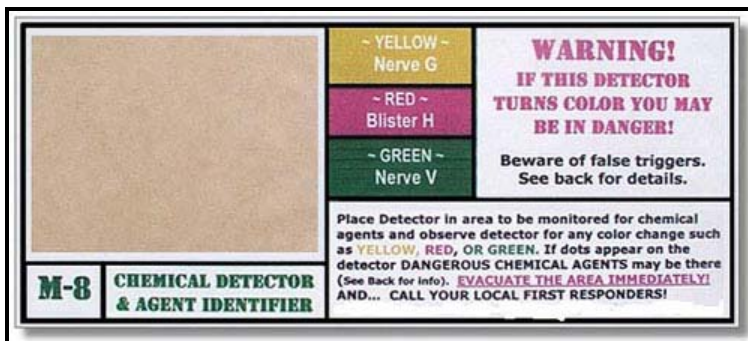

Figure 39: M8 Detection Paper¹²²

M8 paper is issued in a book of 25 tan perforated sheets and contains a printed colour comparison bar chart on the inside of the front cover of the book^{67, 123}. The sheets are usually detached from the book and blotted on suspicious liquids. When activated by CAs, coloured spots appear which are then compared to the colour comparison chart to determine the type of agent present^{122, 123}.

This product was originally designed for military reconnaissance to detect the presence and identity of CAs. It is widely distributed on the battlefield with each soldier carrying M8 paper in their respirator bags¹²².

M8 paper cannot detect vapours nor can it detect CAs in water or aerosol agents in the air. Furthermore some common chemicals such as insect sprays, smoke, acetone, gasoline and strong bleach can cause false readings^{22, 122, 123}.

9.4.1.2 M9 Detection Paper

M9 detection paper, shown in Figure 40, was developed for the U.S. military to enable soldiers to detect 'G', 'V' and 'H' agents in combat¹²². It is still used by ground forces and is placed on personnel and equipment to enable detection of potential liquid CA aerosols¹²².



Figure 40: M9 Detection Paper^{124, 125}

M9 paper is a portable, expendable, single roll of paper with an adhesive backing that allows it to be attached to clothing and equipment^{67, 126}. It is coloured a pale green with insoluble pigments, and contains a suspension of agent sensitive red indicator dye within the paper matrix. It will turn pink, red, reddish brown, or red-purple when exposed to liquid agent but does not change colour to differentiate among the agent types^{22, 126}. Similar to M8 paper, M9 paper is also highly subject to false positives from insect spray, smoke, acetone, gasoline and strong bleach²².

9.4.1.3 3-Way Chemical Agent Liquid Detection Paper

3-Way Chemical Agent Liquid detection paper, shown in Figure 41, was designed to meet the need for a simple, rapid method of detecting and differentiating between liquid 'G', 'V' and 'H' agents¹²⁷.



Figure 41: Three Way Paper Chemical Agent Liquid Detector¹²⁷

The paper comes in booklets of 12 adhesive backed sheets which are impregnated with a dye which is sensitive to liquid agents. Like the M8 paper, testing requires a sheet to be detached and the paper side to be wiped on a suspicious liquid. If the paper turns yellow then liquid 'G' agents are present, red indicates the presence of 'H' agents and purple for 'V' agents¹²⁷.

9.4.2 Colorimetric Detection Tubes

Colorimetric tubes monitor one analyte per test tube and are used to detect gaseous or vaporous CAs. They have been utilised for years by HazMat teams as they are easy to use and familiar to the first responder community^{3, 22}.

The tubes generally consist of a glass tube containing a sorbent material which has had a reagent solution applied to it. When required for use, the tips of the tubes are broken off and a pump is used to draw a sample through it. If a CA is present the sorbent material will change colour. There are many different chemical reagents used in colorimetric tubes, since they are each specific to an agent or compound^{3, 23}.

Detection tubes are typically used for qualitative determinations to verify the presence of a CA after an alarm is received from another monitor³. A typical tube detection system consists of four or five tubes connected to a small pump which pulls a vapour or gas sample through all the tubes at a constant rate. A response is usually achieved within a few minutes however

the results are heavily dependent on the analyte being tested as well as the concentration and the flow rate of sample through the tube²².

Colorimetric tubes, such as those available from Dräger (Lübeck, Germany), shown in Figure 42, are used extensively, however there are some disadvantages. At present there are 160 substance-specific reagent tubes available for identifying different agents. Hence to utilise this technique effectively prior knowledge of which CA is likely to be present is required otherwise a tube for each possible CA must be used for thorough detection and to avoid false negatives⁶⁷.

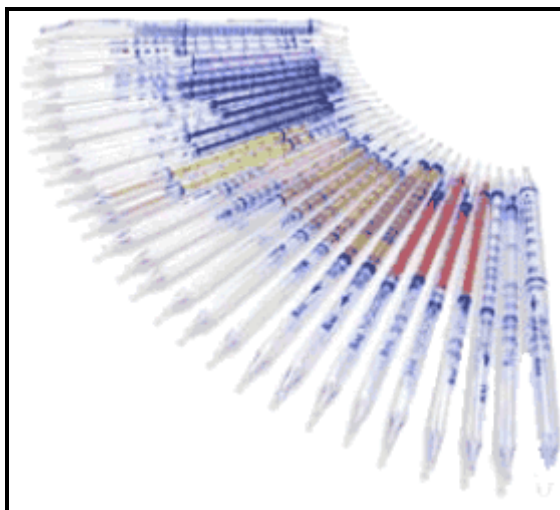

Figure 42: Dräger Colorimetric Tubes¹²⁸

Dräger tubes commonly used for the detection of nerve and blister agents are phosphoric acid ester tubes and thioether tubes, respectively. The phosphoric ester tubes normally change from yellow to pink after exposure to a nerve agent, and as agent concentration increases the pink colour becomes more intense and tends to persist for longer, usually greater than 60 seconds¹²⁹. The thioether tubes form an orange colour band on the yellow portion of the tube when exposed to detectable levels of HD. The intensity of the orange also increases with increased concentration of HD¹²⁹.

These two detection tubes were evaluated by scientists at ECBC and gave excellent results. The phosphoric acid ester tubes detected GA and GB at a minimum concentration of approximately 0.01-0.03 mg/m³ and the thioether tubes detected HD at a minimum concentration of approximately 3-5 mg/m³. They did not respond to any of the interferents that they were subjected to, and their detection thresholds were not severely affected by the humidity and temperature conditions used¹²⁹.

9.4.2.1 Simultaneous Test Sets

A Simultaneous Test Set is shown in Figure 43, and are manufactured by Dräger Safety (Lübeck, Germany)¹³⁰. The Test Sets are comprised of five tubes which are manifolded together and attached to an Accuro hand pump which allows for simultaneous sampling through each of the tubes¹³¹. Hence the Test Set is capable of measuring several gases at once,

therefore greatly increasing gas detection capabilities in a reduced period of time^{130, 131}. Kits utilising this type of technology have been widely accepted in the US and Europe for first responders¹³¹.



Figure 43: Simultaneous Test Sets¹³⁰

There are a number of different Test Sets available for the detection of CAs and clandestine laboratory chemicals¹³⁰. The initial stages of this testing approach involved the introduction of the HazMat Simultest I, II and III and the Civil Defence Simultest (CDS) Sets I and V (in the U.S), for the detection of various nerve, blood, lung, nose and throat irritating agents that might be used in a chemical attack¹³¹. Dräger has since created additional Simultest Sets for the HazMat response market¹³¹. Agent sensitivities for the CDS Sets I and V are seen in Figure 44 and Figure 45, respectively.

AGENT	DRÄGER TUBE	SENSITIVITY
Hydrocyanic Acid	HYDROCYANIC ACID	1 ppm
Phosgene	PHOSGENE	0.2 ppm
Lewisite	ORGANIC ARSENIC COMPOUNDS AND ARSINE	3 mg/m ³ (org. arsenic) 0.1 ppm (arsine)
N - Mustard	ORGANIC BASIC NITROGEN COMPOUNDS	1 mg/m ³
S - Mustard	THIOETHER	1 mg/m ³

Figure 44: Dräger CDS I Tube Sensitivity¹³²

AGENT	DRÄGER TUBE	SENSITIVITY
Nerve Agents	PHOSPHORIC ACID ESTERS	0.025 ppm
Phosgene	PHOSGENE	0.2 ppm
Cyanogen Chloride	CYANOGEN CHLORIDE	0.25 ppm
Chlorine	CHLORINE	0.2 ppm
S - Mustard	THIOETHER	1 mg/m ³

Figure 45: Dräger CDS V Tube Sensitivity¹³²

The HazMat Simultest Sets are specifically designed for gases and organic vapours commonly encountered during HazMat response situations such as fires, chemical spills and investigations of clandestine laboratories¹³². The HazMat Simultest Set I is designed for inorganic gases, including acidic gases such as hydrochloric acid, basic gases such as ammonia, carbon monoxide and hydrocyanic acid, as well as nitrous gases such as nitrogen dioxide¹³⁰. The HazMat Simultest Set II is also designed for inorganic gases, specifically carbon dioxide, chlorine, hydrogen sulphide, phosgene and sulfur dioxide¹³⁰. The HazMat Simultest Set III is intended for organic vapours including alcohols such as methanol, aliphatic hydrocarbons such as n-hexane, aromatic hydrocarbons such as toluene, chlorinated hydrocarbons such as perchloroethylene and ketones such as acetone¹³⁰.

9.4.3 Detection Kits

The most commonly deployed CA Detection Kits include the M-256A1 CA Detection Kit, the M18A3 CA Detector Kit and the CA Water Testing Kit M272. At present there are no packaged Detection Kits for the arsenical vomiting agents, tear gases and incapacitating agents¹³³.

9.4.3.1 M-256A1 CA Detection Kit

The M-256 CA detector kit was originally released in 1978 and in 1987 it was modified so that the kit was more sensitive to lower concentrations of nerve agents. This kit was renamed the M-256A1 CA Detection Kit and is capable of detecting nerve agents (V and G), vesicants (HD, HN and L), and blood agents (AC and CK) and is typically employed to define areas of contamination^{67, 134}. It is commercially available and was heavily utilised by the military during the Gulf War (1990-91)⁶⁷.

The kit is a tool that is generally used by ground forces right after a chemical attack to detect and classify dangerous concentrations of toxic agents (both liquid and vapour). Detection occurs via a colour-changing chemical reaction and the response is used to determine if it is safe for troops to unmask^{125, 134}.

The M-256A1 CA Detection Kit, shown in Figure 46, consists of a carrying case which contains a set of detailed instructions, a booklet of M8 paper and 12 disposable sampler-detectors. The sampler-detectors are enzymatic tickets which contain a square impregnated spot for blister agents, a circular test spot for blood agents, a star test spot for nerve agents, and a Lewisite-detecting tablet and rubbing tab. These test spots are made of standard laboratory filter paper. There are eight glass ampoules, six of which contain reagents for testing and two in an attached chemical heater. When the ampoules are crushed between the fingers, pre-formed channels in the plastic sheets direct the flow of liquid reagent to wet the test spots. Each test spot or detecting tablet develops a distinctive colour, usually within 15 minutes, which indicates whether a CA is, or is not, present in the air. The M-256A1 improvements were the result of employing eel enzymes for the nerve test spots in place of the previously used horse enzymes. This allowed lower levels of nerve agents to be detected^{67, 134, 135}. The kit can be used in temperatures ranging from -32°C to 49°C¹³⁴.



Figure 46: M-256A1 Chemical Agent Detection Kit¹³⁴

By following the directions in the instruction booklet a soldier can conduct a complete test with the liquid-sensitive M8 paper and the vapour-sensitive sampler in approximately 20 minutes¹³⁴. As a result the Kit may be used to (i) determine when it is safe to unmask, (ii) locate and identify chemical hazards and (iii) monitor decontamination effectiveness^{134, 135}.

The M-256A1 can detect nerve agent concentrations of 0.005 mg/m³, mustard concentrations of 0.02 mg/m³ and hydrogen cyanide concentrations of 11 mg/m³, thereby making it one of the military's most sensitive devices for detecting CAs. It can detect all agents at levels below IDLH levels. However, it is prone to false-positive results but to date has not produced false-negative results in real situations⁶⁷.

9.4.3.2 The M18A3 CA Detector Kit

The M18A3 Detector Kit, seen in Figure 47, can be used for both the collection and identification of chemical weapons and TICs¹³³. It is a portable, expendable item capable of surface and vapour analyses and has been designed primarily for detecting dangerous concentrations of vapours, aerosols and liquid droplets of CAs^{125, 136}. However, operators must wear full IPE when using it¹²⁵.



Figure 47: The M18A3 CA Detector Kit¹²⁵

The kit contains detector tubes and paper tickets to detect and classify dangerous concentrations of lethal CAs in the air, as well as liquid CA contamination on exposed surfaces. It also contains sealable sampling tubes, for the safe transport of suspicious, unidentified samples to approved laboratories¹³³. The kit was originally designed to replace the M18A2 Kit. The enhancements made to the M18A3 include the fact that it now contains 40 individual detector tickets sealed in foil packets whereas the M18A2 contained a plastic belt of 40 detector tickets. The M18A3 has also eliminated the need for an aerosol substrate dispenser which was necessary in the M18A2 to activate the detector ticket¹³⁶.

The kit is typically used to confirm the results obtained by the M256A1 Kit as the presence of CAs causes distinctive colour changes^{125, 136}. However, if a CA is suspected but cannot be detected, the Kit allows vapour samples to be collected in sampling tubes which can then be forwarded to a laboratory for analysis and identification^{125, 136}.

This kit can detect V and G nerve agents, mustards including HD, HN-1 and HN-3, blood agents including CK and AC, the choking agent CG, the urticant CX and the arsenicals, L, ethyl dichloroarsine (ED) and methyl dichloroarsine (MD)^{125, 136}.

9.4.3.3 Chemical Agent Water Testing Kit M272

The Chemical Agent Water Testing Kit M272, shown in Figure 48, is designed to test for nerve, HD, L and AC in water¹³⁷. It contains enough detector tubes, detector tickets, a test bottle and prepacked, pre-measured test reagents to conduct 25 tests for each agent¹³⁸. All bodily contact should be avoided with the kit chemicals as they are quite toxic. Therefore operators should wear full IPE⁹⁸.



Figure 48: Chemical Agent Water Testing Kit M272¹²⁴

The kit is designed to detect and identify, via colorimetric reactions, 'V' and 'G' nerve agents to 0.02 ppm, H to 2 ppm, L to 2 ppm and AC to 20 ppm, in treated and untreated water within a total of 20 minutes for all analyses^{98, 138, 139}.

It was originally fielded in 1984; however it no longer meets current lower-level detection requirements¹³⁸.

9.5 Comparison of Colorimetric Based Detectors

There are a number of commercially based colorimetric detectors available each of which has their advantages and disadvantages. Table 9 summarises their capabilities against a number of assessment criteria so that a comparison can be made at a glance.

Table 9: Assessment Criteria for Available Colorimetric Based Detectors

Criteria	M8 paper	M9 paper	3 Way Paper	Tubes	Simultest Sets	M256A1 Kit	M18A3 Kit	M272 Kit
Detected Agents	G- nerve agents, VX, H ¹³³	G, VX, H-liquids ¹³³	G- nerve agents, VX, H ¹²⁷	Different tubes available for detection of specific TICs, TIMs or CAs ¹²	Different sets available for detection of specific TICs, TIMs or CAs ¹²	G- nerve agents, VX, HD, L, CX, Blood- AC & CK in vapour or liquid ¹³³	G- nerve agents, VX, HD, HNs, L, ED, MD, CG, AC in vapour, liquid or aerosol form ¹³³	G- nerve agents, VX, HD, L, AC in 6-7 min ¹³³
Response Times	< 30 sec ¹³³	< 20 sec ¹³³		Variable ¹²	Variable ¹²	15 min or 25 min for AC ¹³³	2-3 min ¹³³	6-7 min ¹³³
Limits of Detection	100 µ drops ¹³³	100 µ drops ¹³³			Detects below IDLH levels or close to AEL ¹²	Nerve- 0.005mg/m ³ , Mustard - 0.02mg/m ³ , L - 2mg/m ³ , CX - 9mg/m ³ , AC & CK - 3mg/m ³ ¹³³	Nerve- 0.1mg/m ³ , Mustard - 0.5mg/m ³ , L, ED, MD - 10mg/m ³ , CG - 12mg/m ³ , AC - 80mg/m ³ ¹³³	Nerve- 0.02mg/m ³ , Mustard - 2mg/m ³ , L - 2mg/m ³ , AC - 20mg/m ³ ¹³³
Simultaneous Detection	Yes.	Yes.	Yes.					
Portability and weight	Handheld ¹³³	Handheld ¹³³	Handheld ¹³³	Handheld ¹³³	Handheld ¹³³	Handheld ¹³³	Handheld ¹³³	Portable/Handheld ¹³³
Power Requirements	NA	NA	NA	NA	NA	NA	NA	NA
Operational Life		3 years shelf life ¹³³				5 years shelf life ¹³³		5 years shelf life ¹³³
Operational Temperature Range (°C)						-32 to 49 ¹³⁴		

10. Photo Ionisation Detection (PID)

PID is a common detection technique used for GC systems in laboratory environments. It is highly sensitive, allowing detection of compounds in very low concentrations (ppb to ppm)¹².

PIDs are typically used in first responder scenarios to give preliminary information about a variety of chemicals as they can detect vapours given off by certain inorganic compounds that other detectors may not. This is because any compound that has an ionisation potential lower than the UV lamp in the detector, can be ionised and subsequently detected^{12, 140}. As such PIDs offer a rapid and convenient indication of whether volatile chemical constituents are present in the air. However, they only provide suggestive, not definitive information about whether a site has been compromised¹⁴⁰.

10.1 PID Technology

PIDs rely on the ionisation of molecules as the basis of detection¹⁴¹. The external energy required to ionise sample molecules is usually provided by a UV source^{12, 22}.

As shown in Figure 49, PIDs operate by passing the sample between two charged metal electrodes in a vacuum chamber irradiated with UV radiation. A sample is ionised when energy from the UV light is absorbed by an atom or molecule. Photons in the radiation knock off electrons in the sample creating positively charged ions^{12, 141}. Hence, for ionisation to occur the energy applied must be greater than the energy needed to remove electrons from the species¹².

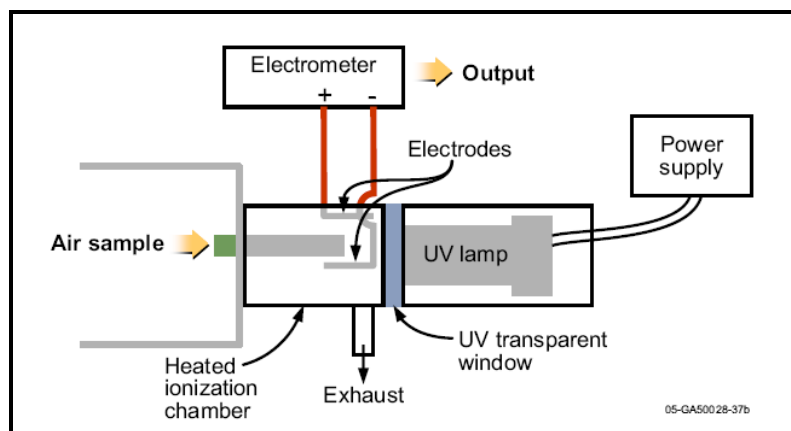

Figure 49: Schematic of PID¹⁴⁰

Newly formed positive ions are attracted to the negatively charged electrode where they release their charge and become neutralised thus generating an electrical current that can be measured. The current produced is related to the amount of ionised substances that enter the detector and as such, proportional to the concentration of the target analyte which is then displayed as a ppm or ppb value on the LED of the instrument^{15, 22, 141}.

In a PID if compounds, such as those in air, have greater ionisation energies than those provided by the PIDs UV lamp they will not be ionised. This eliminates them as potential interfering compounds for detection and analysis. However, water vapour in the atmosphere has been found to cause significant effects on PID instruments. The effect may be caused by factors other than ionisation effects because the ionisation potential of water is higher than the energy supplied by the UV lamp¹².

Isobutylene is typically used to calibrate PIDs as it is stable, relatively easy to handle, readily available and can be stored at high pressure. Instrument responses for other gases are then obtained by multiplying the reading by a correction factor which takes into account the response relative to isobutylene. A list of these correction factors is usually supplied by the manufacturers; however they may vary between manufacturers, between lamps and with the quality of the lamp for the same instrument. Therefore to obtain accurate readings for specific gases, it is necessary to calibrate each gas individually¹⁴⁰.

In the laboratory, aromatic hydrocarbons or heteroatom-containing compounds (like organosulfur or organophosphorus species) are routinely analysed with PIDs. The general rule associated with PID is that if the compounds being measured or detected contain a carbon atom, PIDs can be used^{12, 141}.

10.2 Advantages

PID systems are highly quantitative when compared to a calibrated known sample and provide excellent sensitivity in such situations with limits of detection reaching low ppm levels into ppb levels^{12, 22}.

PIDs are generally utilised as a screening tool as they can provide fast, low-level, on-site screening for chemical contamination. They can determine if a chemical is present and if so, they can accurately measure its concentration^{141, 142}. PIDs are not only limited to the detection of selected CWAs, but are designed to be used in urban environments where virtually any chemical can be found. For example, TICs like ammonia and chlorine are found in large quantities in virtually every community whilst highly toxic chemicals like pesticides (e.g. parathion) and chemical catalysts such as toluene diisocyanate are only slightly less common¹⁴².

Due to the ability of PIDs to provide general screening, they can be fielded in quantity to provide widespread protection and can provide an initial warning so that a more specific detector, such as one based on IMS, can be utilised. This can subsequently ensure that the most appropriate response is taken^{141, 142}.

10.3 Disadvantages

PID systems have very limited specificity and may give many false positives in unknown or mixed environments. They can also be quite costly and complex²².

Utilising PIDs to positively identify a compound requires a chemical separation method, such as GC, to be used before a sample enters the detector¹². When the separation technology is not

used, a PID will give a response to all compounds that can be ionised in a sample¹². Furthermore PIDs have very little ability to differentiate between gases.

10.4 Existing PID Field Detectors

HazMat and other First Responders commonly use PIDs to measure toxic chemicals at ppm and now ppb levels¹⁴². The company, RAE systems (San Jose, CA), have produced a number of PIDs, all of which are quite similar in design and capability; however each new detector released has been enhanced. Another detector currently available utilises PID and Flame Ionisation Detection (FID) simultaneously and is called the TVA 1000B Toxic Vapour Analyser (discussed in 10.4.2).

10.4.1 RAE Systems

RAE systems (San Jose, CA) have developed a number of the commercially available PID-based field detectors which have been deployed by HazMat teams and first responders around the world. These include the MiniRAE 2000, MiniRAE 3000, ppbRAE, ppbRAE 3000, ppbRAE Plus, MultiRAE Plus and ToxiRAE Plus.



Figure 50: (A) MiniRAE 2000¹⁴³, (B) MiniRAE 3000¹⁴⁶

10.4.1.1 *MiniRAE 2000*

The MiniRAE 2000 is shown in Figure 50 (A). It is a small handheld volatile organic compound (VOC) monitor which has a three second response time for concentrations up to 10,000 ppm¹⁴³. It was originally designed to be used for CA detection, initial IPE assessment, leak detection, safety perimeter establishment and maintenance, hazardous material spills, decontamination and remediation¹⁴³.

It is capable of providing real time monitoring information and typically takes less than 30 seconds to warm up. It has a Survey mode and a Hygiene mode. The Survey mode is the factory default and is a discrete sampling mode that can easily start/stop data logging for many points. Hygiene mode is a continuous sampling mode for health and safety applications like confined space entry¹⁴³. This monitor has a self-cleaning lamp and sensor thus minimising the need for maintenance and calibration. It can also be taken apart in seconds without tools¹⁴³.

It has not been independently evaluated against CAs.

10.4.1.2 *MiniRAE 3000*

The MiniRAE 3000, shown in Figure 50 (B), was introduced in 2007 as the new and improved version of the MiniRAE 2000. It has an extended measurement range of 0.1ppm to 15000ppm, giving it the widest measurement range available in the industry for a PID instrument¹⁴⁴. It includes over 200 built-in correction factors for accurately measuring a wide range of chemicals¹⁴⁴. Correction factors, as described previously, are used to allow measurement of a large variety of compounds whilst calibrating with only a single standard gas¹⁴⁵.

The MiniRAE 3000 is designed to provide results in real time providing a measurement response in less than three seconds¹⁴⁴. It provides instantaneous readings for VOCs (as ppm by volume), short term exposure limit (STEL) and TWA, battery shutdown voltage, date, time and temperature¹⁴⁶.

It has a 95 decibel (dB) audible alarm and a flashing red LED visual alarm. For a 'High' alarm the MiniRAE 3000 beeps and the LED flashes three times per second. For the 'Low' alarm it will beep and flash twice per second and the 'STEL' and 'TWA' alarm beeps and flashes once per second¹⁴³.

Other features include a large back-lit graphical display with graphical charting capability and easy viewing in any light condition. For extremely dim environments the monitor has a built in flashlight¹⁴⁴. The MiniRAE 3000 is designed so that the field service of the PID lamp and/or sensor, and the replacement of batteries require no tools and can therefore be performed quickly and easily, in situ¹⁴⁴.

The monitor is waterproof and can be easily decontaminated. It can also be used in humid conditions. It has an optional charging cradle with a USB interface for downloading up to six months of data to a computer for either analysis or record keeping as well as an optional

Bluetooth available for wireless data downloading^{144, 146}. The MiniRAE 3000 has not been independently evaluated.

10.4.1.3 *ppbRAE*

The *ppbRAE*, pictured in Figure 51, is a durable, lightweight handheld monitor designed to continuously monitor dangerous environments for VOCs at ppb levels¹⁴⁷. It has a measurement range of 1 ppb to 200 ppm¹⁴⁸.



Figure 51: *ppbRAE*¹⁴⁸

It has both a visual and audible alarm, which can be preset for low, high, STEL and TWA levels¹⁴⁷. Like the MiniRAE, this monitor also has two modes of operation, the Survey mode and Hygiene mode, as described in section 10.4.1.1.

The *ppbRAE* requires calibration prior to use because it operates by using a sensor reading to calculate the sample concentration based on a known response factor derived from the reference calibration gas, isobutylene¹⁴⁷. Calibrating the *ppbRAE* entails setting the detector baseline to zero by challenging the unit with clean air. Following this the detector is challenged with 10,000 ppb of isobutylene and the instrument reading is set to this value. Once set, the instrument is ready to use¹⁴⁷. According to the manufacturer, no daily instrument calibration should be required as calibrations should hold true for several weeks¹⁴⁷.

An extensive evaluation of the *ppbRAE* was conducted by scientists at ECBC as part of their Domestic Preparedness program. Throughout the course of the evaluation it was found that the monitors required frequent calibration despite the manufacturer's claims otherwise¹⁴⁷. Calibration gas checks before and after agent exposures showed definitive calibration drifts which eventually led to re-calibration of the units several times per day. The requirement for frequent calibration raises doubts about the reliability of each monitor's response. Furthermore the monitors' response to the calibration gas after each agent challenge was

lower than the initial calibrated values which indicated that the sensitivity of the monitors was somehow affected by exposure to CA vapour¹⁴⁷.

Another important finding was that all the detectors evaluated developed symptoms of what appeared to be contamination, which seemed to cause erratic detection of the CA throughout the evaluation¹⁴⁷. Furthermore, it was found that CA vapours, in combination with humidity, appeared to coat the surface of the lamp which affected the sensitivity of the detector¹⁴⁷. As a result, the detector lamps required frequent cleaning. However the performance of the detectors did not improve significantly after cleaning¹⁴⁷. It was thus determined that to maintain a decent level of detector performance, frequent and thorough cleaning is required. However it is not practical nor feasible for first responders to calibrate and clean or replace the lamps after each use¹⁴⁷.

The ppbRAE units were not able to detect GA or GB at the IDLH or AEL levels. However, of the three evaluated detectors, two detected HD at the required level but the other detector did not respond until exposed to a much higher concentration. Furthermore, throughout the evaluation several problems were encountered with these units, the main one being the units' failure to respond. Other problems included calibrations not holding, baselines not clearing, baselines fluctuating, power-up problems, pump error warnings and batteries not lasting in the cold¹⁴⁷.

During the agent challenges, no conclusive temperature and humidity effects could be determined due to the large range of detector readings and the inconsistencies of the three units. However at both temperature extremes (-10°C and +40°C), the detectors responded to lower than MDLs of agent concentration for GA and GB. In general, cold temperatures yielded increased detector responses after agent exposure was stopped, and/or longer recovery times¹⁴⁷.

The detectors were also found to exhibit wide ranges of response factor values between units as well as within the same unit. They displayed varied and inconsistent ppb values when exposed to similar concentrations of CA vapours. Although response factor values for a compound should be constant with varying concentrations, no meaningful relationship between them could be determined by this evaluation¹⁴⁷.

Due to the poor performance of these detector units, testing was discontinued after the agent sensitivity, temperature and relative humidity tests and further testing was considered to be of no value. The manufacturer claims that the ppbRAE is an improved model of the MiniRAE Plus, which has since been discontinued. However it was concluded from the evaluation that the ppbRAE behaviours were similar to the MiniRAE Plus¹⁴⁷. RAE Systems (San Jose, CA) have since ceased manufacturing the ppbRAE.

10.4.1.4 ppbRAE 3000

The ppbRAE 3000, shown in Figure 52, offers an extended measurement range of 1 ppb to 10000 ppm¹⁴⁴. It is manufactured by RAE Systems (San Jose, CA) and was released at the same time as the MiniRAE 3000. It was designed to provide results in real time with a measurement response of less than three seconds as well as for remote monitoring, particularly in rapidly changing environments where headquarters or a command centre can remotely view the real time sensor data and alarm status^{144, 149}.



Figure 52: ppbRAE 3000¹⁴⁹

Like the MiniRAE 3000, this detector is waterproof allowing for easy decontamination, and is suitable for use in humid conditions¹⁴⁴. It features a large back-lit graphical display with graphical charting capability and as such provides easy viewing in any light condition¹⁴⁴. It also features a built in flashlight for operation in extremely dim environments¹⁴⁴. No tools are required to field-service the PID lamp, sensor or to replace batteries. It has an optional charging cradle with a USB interface and optional Bluetooth available for downloading up to six months of data to a computer for either analysis or record keeping¹⁴⁴.

To date, no evaluation has been conducted on this detector and therefore it is unknown if it has been improved from previous versions.

10.4.1.5 *ppbRAE Plus*

The ppbRAE Plus, shown in Figure 53 is a rugged handheld detector that the manufacturer, RAE Systems (San Jose, CA), claims is the most sensitive handheld VOC monitor in the world¹⁵⁰. It is an upgraded version of the ppbRAE and has an expanded measurement range of 1 ppb to 2000 ppm¹⁵⁰.



Figure 53: *ppbRAE Plus*¹⁵⁰

It is slightly different to the afore-mentioned detectors, in that it has an exclusive, disposable VOC zeroing tube which assures repeatability at low-level measurements¹⁵⁰. Like the other PID detectors it is also capable of detecting TICs and CAs within five seconds which enables HazMat teams or First Responders to gain a quick assessment of people in decontamination lines¹⁵⁰.

The manufacturer claims that this detector contains a self-cleaning lamp and sensor which minimises the need for maintenance and, like the previous RAE systems, it requires no tools to field-service the PID lamp and/or sensor or to replace batteries¹⁵⁰.

No evaluation has been conducted on this version of the ppbRAE as yet.

10.4.1.6 *MultiRAE Plus*

The MultiRAE Plus, shown in Figure 54, is claimed to be the only instrument currently available that can offer protection using both standard gas detection sensors for the detection of oxygen, combustible gas, and specific toxic gases, and an integrated PID for broad-range toxic gas detection¹⁵¹. It is manufactured by RAE Systems (San Jose, CA) and can be used as a personal monitor, a hand-held sniffer or a continuously operating area monitor¹⁵².



Figure 54: MultiRAE Plus¹⁵²

The MultiRAE Plus combines a PID with the standard four gases of a confined space monitor. It is a flexible instrument that can be used in confined spaces, emergency response, industrial hygiene and many other monitoring applications^{151, 152}. Furthermore, it is capable of drawing a sample from a distance of more than three metres, both horizontally and vertically¹⁵¹.

The MultiRAE Plus was assessed as part of the System Assessment and Validation for Emergency Responders (SAVER) Program which was established by the U.S. Department of Homeland Security, Preparedness Directorate, Office of Grants and Training to assist emergency responders in performing their duties¹⁵¹. The MultiRAE Plus was evaluated, along with other multi-gas monitors, against five categories comprising of instrument capability, usability, affordability, deployability and maintainability¹⁵¹.

It received the highest overall score in the evaluation, and scored highest in capability and affordability categories. The evaluators found the compact design of the instrument made the MultiRAE easy to handle, although they noted that the detector was not very ergonomic, and when wearing IPE the buttons were difficult to use¹⁵¹. The display was easy to see in all assessment conditions, including bright sunlight and in a dark room, utilising the backlight¹⁵¹. However the evaluators found that the size of the display screen was too small and its location made viewing readings difficult¹⁵¹.

The manufacturer claims that the MultiRAE Plus has a loud audible alarm with varying tones for different alarm conditions, an optional remote vibration alarm for noisy areas and a visual alarm which consists of a flashing LED. The instrument was found to have a good audible alarm but the visual indicator was poorly located and not easily seen unless the operator was looking directly at the screen^{151, 152}.

The MultiRAE was easy for the user to calibrate as it has a one-button calibration with an auto zero capability. The sensors and batteries were also found to be quite easy for the user to change^{151, 152}.

10.4.1.7 ToxiRAE Plus PID

The ToxiRAE Plus PID, Figure 55, is a pocket sized data-logging PID. It is a personal VOC monitor that is able to operate continuously for 10 hours¹⁵³.



Figure 55: ToxiRAE Plus PID¹⁵³

It is small and light enough to wear in a pocket for a full working shift¹⁵³. It is a very convenient tool that can alarm when it is necessary for an individual to take action when VOC thresholds have been reached¹⁵³.

There is limited information available regarding this detector and as yet no evaluation has been conducted to determine the effectiveness of it in the field.

10.4.2 TVA1000B Toxic Vapour Analyser

The TVA1000B Toxic Vapour Analyser, Figure 56, is manufactured by Thermo Electron Corporation (Waltham, MA) and is an over-the-shoulder portable vapour analyser that offers both PID and Flame Ionisation Detection (FID)¹⁵⁴. The advantages associated with having a dual detection system are that it eliminates the time, expense and trouble of purchasing and maintaining two separate analysers. Furthermore, PID offers the user the ability to monitor for organic compounds and many inorganic compounds. Some compounds detected by PID and not FID are ammonia, carbon disulfide, carbon tetrachloride, formaldehyde and hydrogen sulphide. The PID also has the advantage of not requiring fuel or air to operate¹⁵⁴.



Figure 56: TVA1000B Toxic Vapour Analyser¹⁵⁴

The ability to utilise both PID and FID technologies in this field instrument provides benefits in reduced weight and single user interface. Furthermore, the user can easily monitor and log inorganic and organic vapours simultaneously¹⁵⁴.

To date the TVA1000B has not been independently evaluated.

10.5 Comparison of PID- Based Detectors

There are a number of commercially based PIDs available, all of which are summarised in Table 10

Table 10: Assessment Criteria for Available PID Based Detectors

Criteria	MiniRAE 2000	MiniRAE 3000	ppbRAE	ppbRAE 3000	ppbRAE plus	MultiRAE plus	ToxiRAE plus PID	TVA 1000B
Detected Agents	VOCs ¹⁴³	VOCs ¹⁴⁶	VOCs ¹⁴⁸	VOCs ¹⁴⁹	VOCs including TICs and CWAs ¹⁵⁰	VOCs, combustible gases, O ₂ , CO, H ₂ S, SO ₂ , NO, NO ₂ , Cl, HCN, NH ₃ and PH ₃ ¹⁵²	VOCs ¹⁵³	Organic and Inorganic vapours ¹⁵⁴
Response Times	< 3 sec ¹⁴³	< 3 sec ¹⁴⁶	< 5 sec ¹⁴⁸	< 3 sec ¹⁴⁹	< 5 sec ¹⁵⁰		5 sec ¹⁵³	3.5 sec ¹⁵⁴
Limits of Detection	0.1 to 10000 ppm ¹⁴³	0.1 to 15000 ppm ¹⁴⁶	1 to 200 ppm ¹⁴⁸	1 to 10000 ppm ¹⁴⁹	1 to 2000 ppm ¹⁵⁰	0.1 to 2000 ppm ¹⁵²	0.1 to 2000 ppm ¹⁵³	FID - 300 ppb hexane. PID - 100 ppb benzene ¹⁵⁴
Portability and weight	Handheld, weighs 553 grams with battery pack ¹⁴³	Handheld, weighing 738 grams ¹⁴⁶	Handheld, weighing 553 grams with battery pack ¹⁴⁸	Handheld, weighing 738 grams ¹⁴⁹	Handheld weighing 553 grams with battery pack ¹⁵⁰	Handheld, weighing 454 grams with battery ¹⁵²	Handheld, weighing 180 grams with battery ¹⁵³	Weighs 5.8 kg ¹⁵⁴
Power Requirements	Rechargeable, external, field replaceable Nickel Metal Hydride battery pack or 4 AA batteries ¹⁴³	Inter-changeable, drop in, rechargeable lithium ion and alkaline battery packs ¹⁴⁶	Rechargeable, external, field replaceable Nickel Metal Hydride battery pack or 4 AA batteries for alkaline battery pack ¹⁴⁸	Inter-changeable, drop in, rechargeable lithium ion and alkaline battery packs ¹⁴⁹	Rechargeable, external, field replaceable Nickel-Metal-Hydride battery pack or alkaline battery holder for 4 AA batteries ¹⁵⁰	Inter-changeable Lithium ion and alkaline battery packs ¹⁵²	Rechargeable 2.4V, 1100 mAh, nickel-cadmium battery pack or 2 AA alkaline battery adapter ¹⁵³	Rechargeable Nickel-Cadmium Battery ¹⁵⁴
Operational Life	10 hrs continuous operation ¹⁴³	16 hrs continuous operation ¹⁴⁶	10 hrs continuous operation ¹⁴⁸	16 hrs continuous operation ¹⁴⁹	10 hrs continuous operation ¹⁵⁰	14 hrs continuous operation with Li-ion battery. Can run and charge simultaneously ¹⁵²	10 hrs of continuous and instantaneous monitoring of VOCs ¹⁵³	8 hrs ¹⁵⁴
Operational Temperature Range (°C)	-10 to 40 ¹⁴³	-20 to 50 ¹⁴⁶	-10 to 40 ¹⁴⁸	-20 to 50 ¹⁴⁹	-10 to 40 ¹⁵⁰	-20 to 45 ¹⁵²	-20 to 45 ¹⁵³	0 to 40 ¹⁵⁴

11. Flame Ionisation Detection (FID)

Detectors utilising flame ionisation are general-purpose and non-selective, therefore they respond to any molecule containing carbon-hydrogen bonds. However, they do not have the ability to identify the detected compounds^{12, 18}. Due to their non-selective nature, they are considered to be more useful as GC detectors rather than field detection devices for toxic compounds as they are quite limited¹². However, FID has been incorporated in handheld field instruments for the detection of VOCs when precise identification is not a requirement¹².

FID is a similar technique to PID in that compounds in a vapour sample are ionised, however FID instruments use a hydrogen flame as the ionisation method rather than UV radiation¹².

11.1 FID Technology

As shown in Figure 57, FID-based detectors are comprised of a sample inlet, hydrogen fuel inlet, combustion chamber, and electrodes that provide the electric field that acts as the ion collector¹².

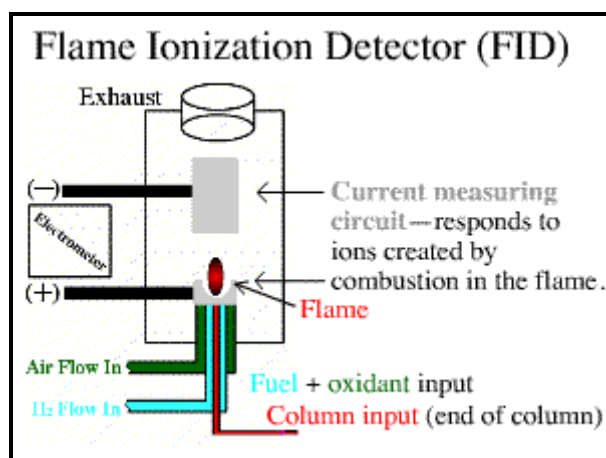

Figure 57: Schematic Diagram of FID¹⁵⁵

Samples can be introduced into a FID either directly or via a GC column. The sample vapour is mixed with hydrogen and air in the combustion chamber and burned, causing the organic substances in the vapour to decompose into fragments which are then ionised. The ions move along the electrical field toward the electrodes where a current is produced and signal generated. The signal is then sent to an electronic signal processor which produces the response¹².

FIDs can only detect CAs through the use of response factors. Response factors allow a detector's response to a known concentration of a given compound to be correlated against a calibrated reference gas, usually methane. However, the usefulness of these response factors, unfortunately, is valid only if the sample contains the targeted chemical without any external influences or interferences¹².

11.2 Advantages

The main advantage of FIDs is that they are insensitive toward non-combustible gases such as water, carbon dioxide, sulfur dioxide and nitrogen oxides and therefore these compounds do not interfere with detection. As a result FIDs are quite often coupled with PIDs to identify VOCs¹².

11.3 Disadvantages

There are a few disadvantages in using FID-based detectors for field CA detection. Firstly they are non-selective and respond to all chemicals that can generate ions via the hydrogen-air flame. Therefore no specific identification and corresponding concentration can be determined based solely on FID response¹². Furthermore a FID can not effectively detect inorganic compounds such as hydrogen sulphide and ammonia¹².

Due to their lack of specificity FIDs generally require the sample to be separated so that target chemicals and their respective concentrations can be determined^{12, 18}. As a result FIDs are not considered to be viable CA detectors because they do not provide specific chemical concentration data¹².

Another major concern associated with FIDs is their requirement for hydrogen gas as a fuel which causes logistical issues¹².

11.4 Existing FID Field Detectors

11.4.1 Photovac MicroFID Handheld Flame Ionisation Detector

The Photovac MicroFID Handheld FID, shown in Figure 58, is manufactured by Perkin Elmer Corporation for the non-specific determination of flammable and potentially hazardous compounds in the concentration range of 0.1 to 50,000 ppm^{18, 156}.



Figure 58: Photovac MicroFID Handheld FID¹⁵⁷

The Photovac MicroFID Handheld FID has been evaluated by ECBC scientists, however the evaluation was shortened after the MDL, response factors and humidity effects measurements indicated that the detector responses to CA were inaccurate and inconsistent at ambient temperature. Therefore further testing at different temperatures and with interferences was not performed¹⁵⁶.

The evaluation was performed on 'as received' detectors and no attempt was made to optimise their CA detection capability¹⁵⁶. Calibrations were performed daily, as stated by the manufacturer; which allowed the detectors to display the concentration in ppm units' equivalent to the calibration gas. The calibration procedure required setting the detector baseline to zero by challenging it with clean air followed by challenging it with a calibration gas to set the sensitivity. The calibration gas was usually 499.7 ppm of methane in air but occasionally 100 ppm of methane in air was used to check the adequacy of the calibration¹⁵⁶. With regard to the baseline response, humidity was found to have no effect, however no conclusive humidity effects on detection could be determined due to the large ranges and inconsistencies of the detector readings¹⁵⁶.

When challenged with CAs, the detectors were not sensitive enough to detect the agents at IDLH or AEL concentration levels and only responded to very high concentrations¹⁵⁶.

Results suggested that the MicroFID in its current configuration cannot be used effectively for CA detection as it performed unpredictably and as such prevented the establishment of a reliable response curve¹⁵⁶. Furthermore, testing was discontinued after the ambient temperature sensitivity tests indicated poor performance toward CA detection. It was thus concluded that the MicroFID detector will not provide a dependable means of detecting the presence of CA vapours¹⁵⁶.

12. Network Sensor Arrays

In recent years, research has been conducted into developing arrays of CA detectors/sensors which integrate the previously discussed, currently available detection technologies. This research aims at utilising the CA detection capabilities of multiple detectors in a large array, in which the detectors are networked back to a central point to enable more selective, sensitive and reliable detection with fewer false alarms. As yet there are no known 'commercial- off-the- shelf' CA detector arrays available.

A suitable, portable CA detector array must incorporate detectors which are small, disposable, have low power requirements and be inexpensive or cost effective for individual deployment, unmanned operational deployment and widespread deployment^{158, 159}. Hence, fully automated detection units could reduce costs and enable frequent monitoring, especially in areas where access is limited or restricted²⁴. In addition, an array must contain multiple detectors that respond rapidly and reversibly to CA vapours, must have built in communication and be capable of being networked^{18, 158}. The most effective detectors would be highly sensitive to, and selective for, dangerous agents at concentrations low enough to allow a hazard to be detected and enable any threat to be mitigated/neutralised through appropriate countermeasures. The heart of such a device would be a sensor capable of recognising the CA without triggering false positives^{12, 159}.

Current sensor array technology devices are based upon the use of an array of several different chemical sensors such as conductive polymers, metal oxide, bulk acoustic wave and SAW devices which can be used simultaneously for real time monitoring¹⁸.

Researchers are concentrating on the use of polymer coatings on micro-scaled sensors so that many of these sensors could be arranged in an array to detect diverse compounds¹². Due to the specificity of polymer coatings, each coating can be made to carry out a reversible chemical reaction for a specific family of compounds. Hence the detection of CAs results from combining inputs from sensor arrays and developing pattern recognition algorithms. However much improvement is required to harden polymers to withstand temperature extremes and vibration stress, increase longevity and make possible fast reversibility without residual effects¹².

More recently, techniques such as chemical resistance, SAW, light emission, semi conductor cells and fibre optics are being used to harvest responses from micro-sensor arrays¹². Gas micro-sensors based upon micro-hotplate sensing technology has also shown promise as a low cost, widely deployable technology for detecting and identifying a number of CAs¹⁵⁹.

Designing miniaturised field deployable devices that can remotely monitor the environment and retain the high sensitivity of sophisticated laboratory based instruments is still a major analytical challenge. Numerous sensing technologies are still at the research stage and may not replace the conventional methods¹⁶⁰.

13. Conclusion

All of the current technologies discussed in this report have their advantages and disadvantages, and there is clearly considerable room for improvement. The major challenges remain increasing detection reliability and reducing the frequency of false responses. The recent emphasis on efforts to develop a capability for detection of a wide range of TICs, in addition to CAs, has also created substantial challenges for researchers and developers. However, while the properties of the chemicals influence the effectiveness of a particular technology, a combination of technologies, in the form of network sensor arrays, may offset problems posed by individual sensors and enable a more robust response¹².

Improvements to chemical detectors still need to meet sensitivities necessary for real time protection of the general population whilst eliminating a tendency for high false alarm rates²⁴. Furthermore, detectors need to be sensitive enough to detect agent concentrations at or below health risk levels, specific enough to provide acceptable false-alarm rates and prompt enough to enable an effective medical response²⁴. Detectors with significantly improved specificity and sensitivity beyond currently available devices will assist in assessing the extent of contamination for effective evacuation and determining when a site is safe for return to normal functions¹².

Current detection capability is somewhat limited, as such there is a need for further research into the development of technologies which are aimed at building improved detectors to accurately provide advanced warning of a CA release¹².

14. References

1. *Chemical and Biological Defense Primer*; USA, October, 2001; pp 1-20.
2. OPCW, Fact Sheet 4: What is a Chemical Weapon? In 2000.
3. *Guide for the Selection of Chemical Agent and Toxic Industrial Material Detection Equipment for Emergency First Responders, Guide 100-04, Volume I and II: Summary*; SAVER July, 2005; pp 1-5.
4. Pearson, G. S., Chemical and Biological Warfare. *Journal of Naval Engineering* **1990**, 32, (2), 190-207.
5. Evison, D.; Hinsley, D.; Rice, P., Chemical Weapons. *BMJ* **2002**, 324, 332-334.
6. CAM - Chemical Agent Monitor. In *Smiths Detection Technical Information*, Smiths Detection.
7. Bobbitt, R., Chemical and Biological reconnaissance technology in the US Army. *Defence Systems International*, 91-94.
8. GID -2A - Chemical Warfare Agent Detection System. In Smiths Detection.
9. *Making the UK safer: detecting and decontaminating chemical and biological agents*; The Royal Society: April, 2004; pp 1-50.
10. Oppenheimer, A., Nuclear, Biological and Chemical detection: To detect and Protect. *Jane's Defence Weekly* **2004**.
11. Ross, S. *Chemical Warfare Agent Properties*; CBRN Defence Centre, DSTO Platforms Sciences Laboratory, Melbourne: 4 October 2006.
12. Sun, Y.; Ong, K. Y., *Detection technologies for Chemical Warfare Agents and Toxic Vapors*. 1st ed.; CRC Press: Boca Raton, Florida, 2005; p 272.
13. Stebbins, M., Types of Chemical Weapons. In Federation of American Scientists.
14. Improved Sensors needed for CB Agents. *Jane's Defence Weekly* 14 August, 1996, pp 19-21.
15. Committee on R&D Needs for Improving Civilian Medical Response to Chemical and Biological Terrorism Incidents, I. o. M., Detection and Measurement of Chemical Agents. In *Chemical and Biological Terrorism: Research and Development to Improve Civilian Medical Response*, NATIONAL ACADEMY PRESS: Washington, D.C., 1999; pp 43-64.
16. Other Technology Applications Areas. In *Technology for the United States Navy and Marine Corps, 2000-2035: Becoming a 21st Century Force*, National Academy of Sciences: 1997; Vol. 2, p 5.
17. Facts About Sulfur Mustard. www.bt.cdc.gov/chemical (4 October 2006),
18. Fatah, A. A.; Barrett, J. A.; Arcitesi, R. D. J.; Ewing, K. J.; Lattin, C., H. ; Helinski, M., S., *Guide for the Selection of Chemical Agent and TIM Detection Equipment for Emergency First Responders* National Institute of Justice: Washington D.C, 2000; Vol. 1, p 1-74.

19. Fatah, A. A.; Barrett, J. A.; Arcitesi, R. D. J.; Ewing, K. J.; Lattin, C., H. ; Helinski, M., S., *Guide for the Selection of Chemical Agent and TIM Detection Equipment for Emergency First Responders* National Institute of Justice: Washington D.C, 2000; Vol. 2, p 1-494.
20. Munro, N. B.; Ambrose, K. R.; Watson, A. P., Toxicity of the organophosphate chemical warfare agents GA, GB, and VX: Implications for public protection. *Environmental Health Perspectives* **1994**, 102, 18-38.
21. La Franchi, P., Chemical and Biological Weapons: The War from Hell. ADM September, 1995, pp 9-10 & 34.
22. Kosal, M., E. *The Basics of Chemical and Biological Weapons Detectors*; Center for Non-proliferation Studies: USA, November 24, 2003.
23. Coutant, S., Features, Chemical Warfare Agent Detection and Personal Protection. *Jane's Defence Weekly* **1999**.
24. Fitch, J. P.; Raber, E.; Imbro, D. R., Technology Challenges in Responding to Biological or Chemical Attacks in the Civilian Sector. *Science* **2003**, 302, (5649), 1350-1354.
25. Aue, W. P.; Guidetti, F. In *Smart Testing of Chemical Detectors*, Symposium on Chemical, Biological, Nuclear and Radiological Threats - A Safety and Security Challenge Tampere, Finland, 18-21 June, 2006; Maatela, P.; Pitkanen, M., Eds. Defence Forces Technical Centre: Tampere, Finland, 2006; pp 82-85.
26. Harper, M., The use of thermal Desorption in Monitoring for the Chemical Weapons Demilitarization Program. *Journal of Environmental Monitoring* **2002**, 4, 688-694.
27. Murray, G. M.; Southard, G. E., Sensors for Chemical Weapons Detection. *IEEE Instrumentation & Measurement Magazine* December, 2002, pp 12-21.
28. Seto, Y.; Kanamori-Kataoka, M.; Tsuge, K.; Ohsawa, I.; Matsushita, K.; Sekiguchi, H.; Itoi, T.; Iura, K.; Sano, T.; Yamashiro, S., Sensing Technology for chemical-warfare agents and its evaluation using authentic agents. *Sensors and Actuators B* **2005**, 108, 193-197.
29. Eiceman, G. A.; Karpas, Z., *Ion Mobility Spectrometry*. CRC Press: Boca Raton, Florida, 1994.
30. Creaser, C. S.; Griffiths, J. R.; Bramwell, C. J.; Noreen, S.; Hill, C. A.; Thomas, C. L. P., Ion Mobility Spectrometry: a review. Part 1. Structural analysis by mobility measurement. *The Analyst* **2004**, 129, 984-994.
31. Ionscan Technology. In Smiths Detection.
32. Brittain, A.; Brokenshire, J., Ion Mobility Spectrometry - Past, Present and Future. In Graseby Dynamics Ltd.
33. Hill, H. H.; Martin, S. J., Conventional analytical methods for chemical warfare agents. *Pure Applied Chemistry* **2002**, 74, (12), 2281-2291.
34. Eiceman, G. A.; Nazarov, E. G.; Rodriguez, J. E.; Bergloff, J. F., Positive Reactant Ion Chemistry for Analytical, High Temperature Ion Mobility Spectrometry (IMS): Effects of Electric Field of the Drift Tube and Moisture, Temperature and Flow of the Drift Gas. *International Society for Ion Mobility Spectrometry* **1998**, 1, 28-37.

35. Harden, C. S.; Shoff, D. B., Detection of Methyl Isocyanate in Air with the use of Hand-Held Ion Mobility Spectrometers. *Field Analytical Chemistry and Technology* **1997**, *1*, (5), 285-294.
36. Hill, H. H.; Simpson, G., Capabilities and Limitations of Ion Mobility Spectrometry for Field Screening Applications. *Field Analytical Chemistry and Technology* **1997**, *1*, (13), 119-134.
37. SIFT-MS: A New Method for the Rapid and Accurate Detection of Security Threats; Syft Technologies: 03 February, 2005.
38. Eiceman, G. A.; Wang, Y.-F.; Garcia-Gonzalez, L.; Harden, C. S.; Shoff, D. B., Enhanced selectivity in ion mobility spectrometry analysis of complex mixtures by alternate reagent gas chemistry. *Analytica Chimica Acta* **1995**, *306*, 21-33.
39. ECAM - Enhanced Chemical Agent Monitor. In *Smiths Detection Technical Information*, Smiths Detection.
40. CAM- 2 Chemical Agent Monitor. In *Smiths Detection Technical Information*, Smiths Detection.
41. Longworth, T. L.; Ong, K. Y. *Domestic Preparedness Program: Testing of the CAM-Chemical Agent Monitor (Type L) against Chemical Warfare Agents Summary Report*; Aberdeen Proving Grounds, Maryland, August, 2001; pp 1-19.
42. Improved Chemical Agent Monitor (ICAM). In Federation of American Scientists; Military Analysis Network: 1999.
43. Ong, K. Y.; Longworth, T. L.; Barnhouse, J. L. *Domestic Preparedness Program: Testing of APD2000 Chemical Warfare Agent Detector Against Chemical Warfare Agents Summary Report*; Aberdeen Proving Grounds, Maryland, August, 2000; pp 1-12.
44. APD 2000 - Advanced Portable Chemical Agent Detector. In Smiths Detection.
45. *Ion mobility Spectrometry (IMS) Chemical Detectors Analysis Report summary*; System Assessment and Validation for Emergency Responders (SAVER) Program: April, 2006; pp 1-6.
46. Dräger Multi-IMS - A Short Introduction Into The Operation. In Drager Safety: 2003.
47. ChemRae. <http://www.raesystems.com/products/chemrae> (18 August 2008),
48. Derringer, T.; Kelly, T.; Folsom, D.; Krile, R.; Wilenberg, Z.; Koglin, E. *EnviroNics USA Inc. ChemPro 100 Hand-Held Chemical Detector*; Battelle: Columbus, Ohio, June, 2006; pp 1-35.
49. ChemPro100 Handheld Chemical Detector.
<http://www.enviroNicsusa.com/Chempro.htm?page=chempro> (16 July 2007),
50. Lancaster, P. *DSTO Evaluation of Multi-IMS*; DSTO: 2006.
51. Daltonics, B., RAID-M-100 (based on the RAID-M), Hand-held Chemical Agent Monitor. In Bruker.
52. Technologies: RAID-M Handheld Chemical Agent Detector
http://www.htfwo.org/ertProgram/technologies/category.asp?start_from=2&SearchText=&Agency=5&category=59&Type_ID=4&Assessed= (16 July 2007),

53. Hofacre, K.; Derringer, T.; Folsom, D.; Larkowski, P.; Kelly, T.; Sinnott, L.; Hamilton, C.; Willenberg, Z. *Bruker Daltonics Inc. RAID-M Ion Mobility Spectrometer*; Battelle: Columbus, Ohio, April, 2004; pp 1-45.
54. Baranoski, J. M.; Longworth, T. L. *Domestic Preparedness Program Evaluation of the RAID-M (Bruker Saxonix Analytik GmbH Rapid Alarm and Identification Device- Monitor) Against Chemical Warfare Agents Summary Report*; Aberdeen Proving Grounds, Maryland, December, 2003; pp 1-22.
55. Traeger, J. C. *Strategy for Incidental Detection of Chemical Warfare Agents by Australian Customs*; 2006; pp 1-8.
56. IMS 2000: Chemical Warfare Agent Detector. In Bruker Daltonics.
57. IMS 2000. <http://www.levitt-safety.com/WhatsNew/DomesticResponse/Bruker.htm> (18 July 2007),
58. Baranoski, J. M.; Longworth, T. L. *Domestic Preparedness Program Evaluation of the IMS2000 (Bruker Daltonics GmbH Ion Mobility Spectrometer 2000) Against Chemical Warfare Agents Summary Report*; Aberdeen Proving Grounds, Maryland, July, 2003; pp 1-28.
59. GID-3 - Chemical Warfare Agent Detection System GID-3. In *Smiths Detection Technical Information*, Smiths Detection.
60. GID-3 Chemical Warfare Agent Detection System. In Smiths Detection.
61. Lancaster, P. A. *Detection and Monitoring of Chemical Warfare Agents*; Human Protection and Performance Division, DSTO: 2006.
62. SABRE 4000. In *Smiths Detection Technical Information*, Smiths Detection.
63. Longworth, T. L.; Ong, K. Y. *Domestic Preparedness Program: Testing of Sabre 2000 Handheld Trace and Vapor Detector Against Chemical Warfare Agents Summary Report*; Aberdeen Proving Ground, Maryland, August, 2001; pp 1-28.
64. LCD-3 - Lightweight Personal Chemical Detector LCD-3 series. In *Smiths Detection Technical Information*, Smiths Detection.
65. LCD- Lightweight Chemical Detector. In Smiths Detection.
66. Taylor, S. J., LCD-3 Technical product Specification. In Smiths Detection: 2002.
67. Davis, G. CBRNE - Chemical Detection Equipment. <http://www.emedicine.com/emerg/topic924.htm> (01 August),
68. Nieuwenhuizen, M. S., Detection and Screening of Chemicals Related to the Chemical Weapons Convention. In *Encyclopaedia of Analytical Chemistry*, Meyers, R. A., Ed. John Wiley & Sons Ltd: 2006; pp 1-17.
69. Frishman, G.; Amirav, A., Fast GC-PFPD System for Field Analysis of Chemical Warfare Agents. *Field Analytical Chemistry and Technology* **2000**, 4, (4), 170-194.
70. Introduction to Flame Spectroscopy. In SA, P., Ed. Proengin SA: Saint-Cyr L'Ecole, France.
71. AP2C Chemical Warfare Agent Detector. In Arrow - Tech: Vol. 2007.
72. AP2C. http://www.proengin.com/fp_ap2c.htm (06 August),

73. AP2Ce. http://www.proengin.fr/fp_ap2ce.htm (19 August 2008),
74. Longworth, T. L.; Ong, K. Y. *Domestic Preparedness Program: Testing of Detectors Against Chemical Warfare Agents - Summary Report; UC AP2C Portable Chemical Contamination Control Monitor Collective Unit*; Aberdeen Proving Ground, Maryland, May, 2001; pp 1-20.
75. Clarke, P. E., Sensor Detection Advances at a Geometric Pace. In *Military Medical Technology - Online Edition 2006*; Vol. 10.
76. AP4C. http://www.proengin.com/index.php?option=com_content&task=view&id=25&Itemid=32 (19 August 2008),
77. MINICAMS Series 3001 Continuous Air Monitor. <http://www.oico.com/default.aspx?id=product&productID=75> (01 August),
78. UC AP4C. In SA, P., Ed. Proengin SA: Saint -Cyr L'Ecole, France.
79. Introduction to Fourier Transform Infrared Spectrometry. In Nicolet, T., Ed. Thermo Nicolet: Madison, pp 1-7.
80. Longworth, T. L.; Barnhouse, J. L.; Ong, K. Y. *Domestic Preparedness Program: Testing of MIRAN SapphIRe Portable Ambient Air Analyzers Against Chemical Warfare Agents Summary Report*; Aberdeen Proving Ground, Maryland, July, 2000; pp 1-13.
81. Photoacoustic Detection (PAS). In Innova: Vol. 2007.
82. Fourier Transform Spectrometer. http://www.umaine.edu/misl/ft_spectrometer.html (21 August),
83. M21 Remote Sensing Chemical Agent Alarm. In Network, F. M. A., Ed. Federation of American Scientists: Military Analysis Network: 1999; Vol. 2007.
84. Nuclear-Biological-Chemical (NBC) Defense Systems. *Army* October, 2006, pp 361-368.
85. Hammond, B.; Popa, M., Overview of the Joint Services Lightweight Standoff Chemical Agent Detector (JLSCAD). *Proceedings of SPIE 2005*, 5795, 86-95.
86. Product Overview: MIRAN SapphIRe Portable Infrared Ambient Analyzer. In Thermo Electron Corporation.
87. AN/KAS-1A Chemical Warfare Directional Detector. In Federation of American Scientists; Military Analysis Network: 1998.
88. AN/KAS-1 Chemical Warfare Directional Detector (CWDD). In *Electronics Technician Integrated Publishing*: Vol. 9.
89. HazMatID™ Chemical Identifier; Training Course: Infrared Spectroscopy for Hazardous Materials Identification. In Smiths Detection: 2005.
90. Ong, K. Y.; Baldauf, F. C.; Carey, L. F.; St. Amant, D. C. *Domestic Preparedness Program: Evaluation of the TravellIR HCI Hazmat Chemical Identifier*; Aberdeen Proving Grounds, Maryland, August, 2003; pp 1-32.
91. TravelIR HCI. In SensIR Technologies: Danbury.

92. The HazMatID. <http://www.sensir.com/Smiths/HazMatID/HazMatID.htm> (10 September 2007),
93. Team, F. L. H. M. *Operational Test and Evaluation Report for The HazMatID Fourier Transform Infrared Chemical/Biological Analyzer*; Fort Lauderdale, Florida, April 4, 2004.
94. HazMatID. In SensIR Technologies: Danbury.
95. IlluminatIR. In SensIR Technologies: 2001.
96. IlluminatIR. In SensIR Technologies: Danbury.
97. JSLSCAD: Joint Service Lightweight Standoff Chemical Agent Detector. In General Dynamics Armament and Technical Products.
98. O'Hern, M. R.; Dashiell, T. R.; Tracy, M. F., Chemical Defence Equipment. In *Textbook of Military Medicine: Medical Aspects of Chemical and Biological Warfare*, Zajtchuk, R.; Bellamy, R. F.; Sidell, F. R.; Takafuji, E. T.; Franz, D. R., Eds. The Office of The Surgeon General at TMM Publications: Washington DC., 1997; pp 361-396.
99. M21 Remote Sensing Chem Alarm
<http://tech.military.com/equipment/view/88651/m21-remote-sensing-chem-alarm.html> (19 August 2008),
100. Matthews, R. L.; Ong, K. Y.; Brown, C. D.; Zhu, L.; Knopp, K. *Evaluation of Ahura's FirstDefender Handheld Chemical Identifier*; Aberdeen Proving Ground, Maryland, January, 2006; pp 1-53.
101. *Raman Spectroscopy - An Overview*; Ann Arbor, MI, 2001.
102. Developments in Raman Spectroscopy.
www.ecbc.army.mil/about/features/raman_spectroscopy.htm (01 October 2007),
103. Hawley, C., New Technologies for WMD Detection. *Fire Engineering WMD Supplement 2005*, 26 - 29.
104. FirstDefender: Handheld Identification of WMD, Explosives, Narcotics & TICs. In Ahura Corporation: Wilmington, 2004.
105. FirstDefender XL: Rugged, Handheld Identification of WMDs, Chemical Agents, Explosives, TICs, TIMs, Narcotics & Powders. In Ahura Corporation: Wilmington, 2006.
106. NBC Recon and Obscuration: Joint Contaminated Surface Detector (JCSD)
In Joint Program Technical Office: Chemical and Biological Defense.
107. Jean, G., Laser-Based Sensor Will Sniff Out Chemicals on the Move *National Defense 2006*.
108. Biosystems and Nanomaterials; Paws Systems (Portable Acoustic Wave Sensor).
<http://www.sandia.gov/mstc/technologies/microsensors/paws.html>
109. Milner, G. M., Detection/ Classification/ Quantification of Chemical Agents Using an Array of Surface Acoustic Wave (SAW) Devices. *Proceedings of SPIE 2005*, 5778, 305-316.

110. Cajigas, J. C.; Longworth, T. L.; Davis, N.; Ong, K. Y. *Testing of HAZMATCAD Detectors Against Chemical Warfare Agents: Summary Report of Evaluation Performed at Solider Biological and Chemical Command (SBCCOM) Aberdeen Proving Ground, Maryland, January, 2003*; pp 1-12.
111. Surface Acoustic Wave (SAW) Sensing [Technology for the Detection of Nerve and Blister Agents]. In MSA: Pittsburgh, USA., 2005.
112. Hazardous Material Chemical Detector: Microsensor Systems - HAZMATCAD & HAZMATCAD Plus. In Arrow-Tech, Inc.: Rolla, North Dakota.
113. Laljer, C. E., Joint Chemical Agent Detector (JCAD): The Future of Chemical Agent Detection. *Proceedings of SPIE 2003*, SPIE-5085, 64 - 74.
114. ChemSentry 150C Point Chemical Vapour Detector System. In BAE Systems: Austin, Texas, 2003.
115. Chemical Agent Detector: Permanently Installed Chemical Agent Detector CW Sentry Plus. In Arrow-Tech Incorporated: Rolla, North Dakota.
116. Acoustic Wave Sensors. In Purdue University: Division of Construction and Engineering Management.
117. SAW MiniCAD mk II Miniature Chemical Agent Detector. In MSA: 2007.
118. Longworth, T. L.; Ong, K. Y.; Johnson, M. A. *Domestic Preparedness Program: Testing of SAW MiniCAD MKII Detector Against Chemical Warfare Agents Summary Report*; Aberdeen Proving Ground, Maryland, September, 2001; pp 1-19.
119. SAW MiniCAD mk II: Chemical Warfare Agent Detector. In MSA: The Safety Company: Pittsburgh, 2006.
120. ChemSentry 150C Detector System Features Guide. In BAE Systems: Austin, Texas, 2004.
121. Detection of Chemical Weapons. In Organisation for the Prohibition of Chemical Weapons.
122. Chemical Agent Detection. In Security and Safety Supplies.
123. M8 Chemical Agent Detector Paper. In Tradeways Ltd: Annapolis, MD.
124. Plackes, J., NBCDE Detection Graphics. In 2007.
125. Ingles, S., Chemical and Biological Protection, Detection and Decontamination Items. In (SBCCOM-R1), U. A. S. a. B. C. C., Ed. 2001.
126. M9 Chemical Detector Paper. In Tradeways Ltd: Annapolis, MD.
127. Three Way Paper Chemical Agent Liquid Detector. In Tradeways Ltd: Annapolis, MD.
128. Gas Detection & Respiratory Protection. In DEGESCH America, Inc.
129. Longworth, T. L.; Cajigas, J. C.; Barnhouse, J. L.; Ong, K. Y.; Procell, S. A. *Domestic Preparedness Program: Testing of Commercially Available Detectors Against Chemical Warfare Agents: Summary Report*; Aberdeen Proving Ground, Maryland, February, 1999; pp 1-11.

130. Dräger Tube Sets: Simultaneous Test Sets. In Dräger safety.
131. Ligus, E., Dräger Simultest Technology for Clandestine Laboratories. *Dräger Review* 2003, 1, 10-11.
132. First responder Products: Domestic Preparedness. In Dräger Safety, Inc.: Pittsburgh, P.A., pp 1-4.
133. Murray, G. M.; Lawrence, D. S., Hazardous Environment Monitoring. In *Chemical Weapons Convention Chemicals Analysis: Sample Collection, Preparation and Analytical Methods*, Mesilaakso, M., Ed. John Wiley & Sons Ltd.: West Sussex, U.K., 2005; pp 65-88.
134. M256A1 Chemical Agent Detector Kit. In *U.S. Army Equipment Information, Army Study Guide*: 2005.
135. M256A1 Chemical Agent Detector Kit. In Tradeways Ltd: Annapolis, MD.
136. Chemical Agent Detector Kit, ABC-M18A3. In Tradeways Ltd: Annapolis, MD.
137. Chemical Agent Water Testing Kit M272. In Tradeways Ltd: Annapolis, MD.
138. Hoenig, S. L., *Handbook of Chemical Warfare and Terrorism*. Greenwood Press: WestPort, CT., 2002.
139. *Naval Force's Defense Capabilities against Chemical and Biological Warfare Threats*. National Academics Press: 2004.
140. Daum, K. A.; Watrous, M. G.; Neptune, M. D.; Michael, D. I.; Hull, K. J.; Evans, J. D. *Data for First Responder Use of Photoionization Detectors for Vapor Chemical Constituents*; Idaho national Laboratory; Neptune and Company; SAIC: November, 2006; pp 1-78.
141. Photoionization Detectors (PIDs) Theory, Uses and Applications for First Responders, Law Enforcement Agents, HazMat and Fire Service Professionals. In MSA: Pittsburgh.
142. Wrenn, C. *Using PIDs in Terrorist Chemical Attacks*; RAE Systems: Sunnyvale, CA.
143. MiniRAE 2000 Portable Handheld VOC Monitor. In Rae Systems: San Jose, CA.
144. Durstenfeld, B. *RAE Systems Introduces Two 3rd Generation Photoionization Detectors for Volatile Organic Compounds*; RAE Systems: San Jose, California, June 4, 2007.
145. *Correction Factors, ionization Energies, and Calibration Characteristics*; RAE Systems: San Jose, California.
146. MiniRAE 3000 Portable Handheld VOC Monitor. In RAE Systems San Jose, CA.
147. Longworth, T. L.; Ong, K. Y. *Domestic Preparedness Program: Testing of RAE Systems ppbRAE Volatile Organic Compound (VOC) Monitor Photo-Ionization Detector (PID) Against Chemical Warfare Agents Summary Report*; Aberdeen Proving Ground, Maryland, September, 2001; pp 1-17.
148. ppbRAE PID. In Concept Controls Inc. Innovative Safety and Instruments.
149. ppbRAE 3000 Portable Handheld VOC Monitor. In RAE Systems: San Jose, CA.
150. ppbRAE Plus VOC Detector Monitor. In RAE Systems: San Jose, CA.
151. MulitRAE PLUS: One-to-Five Gas Monitor with VOC Detection. In ENVCO Global.

152. MultiRAE Plus. In RAE Systems: San Jose, CA.
153. ToxiRAE Plus PID: PID Personal Gas Monitor. In RAE Systems: San Jose, CA.
154. Product Overview TVA1000B Toxic Vapor Analyzer. In Thermo Electron Corp: Franklin, MA.
155. Chasteen, T. G., The Flame Ionization Detector. In Department of Chemistry, Sam Houston State University, Huntsville, Texas 2000.
156. Longworth, T. L.; Barnhouse, J. L.; Ong, K. Y.; Johnson, M. A. *Domestic Preparedness Program: Testing of Photovac MicroFID Handheld Flame Ionization Detectors against Chemical Warfare Agents - Summary Report*; Aberdeen Proving Ground, Maryland, October, 1999; pp 1-7.
157. MicroFID In Photovac, Inc.
158. Rippen, M., Chemical and Biological Agent Sensor/Detector Systems Technology Development for Applications in the Global War on Terrorism. In Concurrent Corporation: 2004.
159. Meier, D. C.; Taylor, C. J.; Cavicchi, R. E.; White V, E.; Ellzy, M. W.; Sumpter, K. B.; Semanick, S., Chemical Warfare Agent Detection Using MEMS-Compatible Microsensor Arrays. *IEEE Sensors Journal* **2005**, 1-14.
160. Sadik, O. A.; Wanekaya, A. K.; Andreescu, S., Advances in Analytical Technologies for Environmental Protection and Public Safety. *Journal of Environmental Monitoring* **2004**, 6, 513-522.

DEFENCE SCIENCE AND TECHNOLOGY ORGANISATION DOCUMENT CONTROL DATA				1. PRIVACY MARKING/CAVEAT (OF DOCUMENT)	
2. TITLE A Review of Chemical Warfare Agent (CWA) Detector Technologies and Commercial-Off-The-Shelf Items			3. SECURITY CLASSIFICATION (FOR UNCLASSIFIED REPORTS THAT ARE LIMITED RELEASE USE (L) NEXT TO DOCUMENT CLASSIFICATION) Document (U) Title (U) Abstract (U)		
4. AUTHOR(S) Rodi Sferopoulos			5. CORPORATE AUTHOR DSTO Defence Science and Technology Organisation 506 Lorimer St Fishermans Bend Victoria 3207 Australia		
6a. DSTO NUMBER DSTO-GD-0570		6b. AR NUMBER AR-014-414		6c. TYPE OF REPORT General Document	7. DOCUMENT DATE March 2009
8. FILE NUMBER 2008/1056875	9. TASK NUMBER CDG 07/266	10. TASK SPONSOR Project Director JP2110		11. NO. OF PAGES 98	12. NO. OF REFERENCES 160
13. URL on the World Wide Web http://www.dsto.defence.gov.au/corporate/reports/DSTO-GD-0570.pdf			14. RELEASE AUTHORITY Chief, Human Protection and Performance Division		
15. SECONDARY RELEASE STATEMENT OF THIS DOCUMENT <i>Approved for public release</i> OVERSEAS ENQUIRIES OUTSIDE STATED LIMITATIONS SHOULD BE REFERRED THROUGH DOCUMENT EXCHANGE, PO BOX 1500, EDINBURGH, SA 5111					
16. DELIBERATE ANNOUNCEMENT No Limitations					
17. CITATION IN OTHER DOCUMENTS Yes					
18. DSTO RESEARCH LIBRARY THESAURUS http://web-vic.dsto.defence.gov.au/workareas/library/resources/dsto_thesaurus.shtml chemical warfare agent detectors					
19. ABSTRACT This report provides a review of the open-source literature (unclassified) and information obtained from manufacturers regarding the technologies, including advantages and disadvantages, used in commercially available equipment currently employed for the detection of chemical warfare agents (CWAs) and toxic industrial chemicals (TICs). A brief description of the well-known, commercial-off-the-shelf instruments that employ these technologies is also provided.					