

Report Documentation Page

*Form Approved
OMB No. 0704-0188*

Public reporting burden for the collection of information is estimated to average 1 hour per response, including the time for reviewing instructions, searching existing data sources, gathering and maintaining the data needed, and completing and reviewing the collection of information. Send comments regarding this burden estimate or any other aspect of this collection of information, including suggestions for reducing this burden, to Washington Headquarters Services, Directorate for Information Operations and Reports, 1215 Jefferson Davis Highway, Suite 1204, Arlington VA 22202-4302. Respondents should be aware that notwithstanding any other provision of law, no person shall be subject to a penalty for failing to comply with a collection of information if it does not display a currently valid OMB control number.

1. REPORT DATE MAY 1923	2. REPORT TYPE	3. DATES COVERED 00-00-1923 to 00-00-1923			
4. TITLE AND SUBTITLE The Coast Artillery Journal. Volume 58, Number 5, May 1923		5a. CONTRACT NUMBER			
		5b. GRANT NUMBER			
		5c. PROGRAM ELEMENT NUMBER			
6. AUTHOR(S)		5d. PROJECT NUMBER			
		5e. TASK NUMBER			
		5f. WORK UNIT NUMBER			
7. PERFORMING ORGANIZATION NAME(S) AND ADDRESS(ES) Coast Artillery Training Center, Coast Artillery Journal, Fort Monroe, VA, 23651		8. PERFORMING ORGANIZATION REPORT NUMBER			
9. SPONSORING/MONITORING AGENCY NAME(S) AND ADDRESS(ES)		10. SPONSOR/MONITOR'S ACRONYM(S)			
		11. SPONSOR/MONITOR'S REPORT NUMBER(S)			
12. DISTRIBUTION/AVAILABILITY STATEMENT Approved for public release; distribution unlimited					
13. SUPPLEMENTARY NOTES					
14. ABSTRACT					
15. SUBJECT TERMS					
16. SECURITY CLASSIFICATION OF:			17. LIMITATION OF ABSTRACT	18. NUMBER OF PAGES	19a. NAME OF RESPONSIBLE PERSON
a. REPORT unclassified	b. ABSTRACT unclassified	c. THIS PAGE unclassified	Same as Report (SAR)	96	



A. MACHINE GUN EMPLACEMENT, BATTERY C, 61ST ARTILLERY BATTALION, ANTI-AIRCRAFT.

The Coast Artillery Journal

Vol. 58 No. 5

MAY, 1923

Whole No. 201

Military Reasons for Paying for Supplies in the Enemy's Country

By Colonel Samuel C. Vestal, C. A. C.



AN army operating in enemy, allied, neutral, or home territory may live off the country or it may bring supplies from a distance; or it may employ a combination of these methods. No region is rich enough to feed a large army indefinitely. Much food must therefore be brought from a distance, as well as ammunition and other fabricated articles; but the great bulk of the supplies, the raw materials of construction, must, on account of their bulk, be obtained in the country where the army is operating.

Freedom of movement in the enemy's country is possible only where a full use is made of the resources of the theatre of war.

"On no account," wrote Napoleon to Junot on November 2, 1807, "halt in your march even for a day. The want of provisions can be no reason for doing so, still less the state of the roads. Twenty thousand men can march and live anywhere, even in a desert."

In the last sentence Napoleon states, in an exaggerated form, one of the great principles of supply, namely, that food and forage in the enemy's country constitute advanced depots for an invading army able to drive back its adversary. But the rule must be qualified with many exceptions and explanations. All of these, unfortunately, were violated by Junot, who advanced on Lisbon at a break-neck speed, through drenching rains, over miserable roads, pillaging and burning, and committing every species of outrage. The inhabitants fled, concealing their flocks and herds. Junot's army virtually dissolved; and he himself arrived at Lisbon with two thousand famishing men, resembling fugitives at the end of a disastrous retreat.

To obtain the maximum of supplies from the enemy's country requires a combination of intimidation, cultivated good-will, and assurance of ready payment in the coin of the country. Ready payment and

rigid discipline are constant and indispensable factors in order to stimulate production and secure the aid of the inhabitants in collecting supplies. The policy of paying for supplies in the enemy's country and of respecting the rights of private property is associated with the names and the successes of Henry V of England, Charles XII of Sweden, Gustavus Adolphus, Wellington, and Winfield Scott. Henry V forbade injuries to property and insults to women; and the justice of his military government of occupied territory and the discipline of his armies made the French "almost forget that he was an enemy," and in no small measure contributed to his wonderful success. Similar things may be said of the other great soldiers who knew how to win the friendship of enemy populations and discount the disadvantages of operating in enemy territory. The Mexicans offered Scott the kingship of their country.

Supplies are easily procured in rich, well inhabited, well cultivated countries, having good roads, and ample means of transport; but the amount of supplies that money can bring forth in districts not so well favored has often been a matter of astonishment to invaders who were willing to pay for them. During the siege of Chattanooga, General Sheridan sent a troop of cavalry into the Sequatchie Valley to collect supplies for his division. The troop concealed itself in a cove, and by keeping quiet and paying for everything it took, was enabled to send large quantities of corn to Sheridan for his animals, and food for his officers and men. "In this way," says Sheridan, "I carried men and animals through our beleaguement in pretty fair condition." The other divisions of the army were starving.

Requisitions are demands for food, forage, material, labor, and transportation served upon the inhabitants of a theatre of war, either in friendly or enemy territory. Supplies and services thus obtained may be paid for, or appropriated without payment. Requisitions paid for at remunerative prices place the whole resources of a region at the disposal of the invader through the agency of the people themselves. Requisitions may be necessary and advisable, not only in the enemy's country, but in friendly territory; and the method of payment should be the same in both regions. Protection to civilian inhabitants and prompt payment for any supplies taken, enlist the cooperation of the inhabitants, even of an enemy's country.

The necessity for requisitions varies from the most absolute degree in the care of the sick and wounded and the burial of the dead after a battle, to a mere matter of convenience in exploiting the resources of the region close to the scene of action.

Every nation should have a requisition law, applicable to its own territory, as it will be needed in case of invasion. The nation which has such a law and applies it in the enemy's country cannot go far astray in its military policy. We had the most essential part of such a law in our price-fixing regulations during the World War.

The benefit from paying for supplies procured in the enemy's country comes in saving transportation, which, in a war of maximum effort, is priceless. Unpaid requisitions cannot be justified as a means of saving the home country from taxation, as the amount saved in direct payment is more than counterbalanced by the necessity of bringing a greater amount of supplies from a great distance, and by the greater overhead required for production at home. The most economical way to provide an army is by purchase in the region where the supplies are needed.

The invader should exercise a rigid economy of these resources purely out of regard for his own interests. Fortunately, this requirement accords with the dictates of the truest and most gallant feelings of humanity.

When the cost of an article purchased at home and transported to the firing line is taken into account, it will readily be seen that an invading army can afford to pay prices for articles in the theater of operations that will be attractive to any but the most austere and rigid of the enemy population. Luckily for the invader, most of the austere and rigid patriots, who would rather burn their supplies than turn them over to an enemy, leave the country before his arrival. Generally the poorer citizens remain and become dependent upon the protection of the invader. It is of the utmost importance to the invader that the peaceful and industrious inhabitants remain in the occupied territory.

In the rear of a large army, confidence becomes gradually reestablished, the magistrates return, and the people resume the commercial pursuits which minister to the needs of the army; but a short period of exactions and cruelty may drive the civilian population to take a fatal view of its duty as an integral part of the enemy body politic, and lead to guerrilla warfare and the systematic destruction of supplies in the occupied territory.

Unpaid requisitions press most heavily upon the class of people who have least interest and least desire for war. They can be justified only as a punishment, as an extreme measure, often threatened but rarely put into execution.

Enemy complaint is loud and insistent when the inhabitants of occupied territory receive payment for supplies, as did the peaceful inhabitants during the British occupation of Philadelphia in 1777-78; but enemy complaint is vociferous and the outside world joins in the chorus when supplies are taken without payment. The prices actually paid should be determined by the principle of price-fixing.

It may be thought that troops engaged in raids and rapid movements should be allowed to forage freely, and that payment should be reserved for that part of the enemy's territory which is securely occupied. This comes very near the system pursued by the Federal forces in the Civil War; but it does not give satisfactory results. The fact is that the great obstacle in securing the cooperation of the enemy population is found, not in the enemy population, but in the invader's own troops. The idea uppermost in the minds of many officers and men is that it is their privilege to provide themselves, at the cost of the enemy, with all the comforts immediately in sight. "The enemy does it," they say, "and we have a right to." They think only of immediate enjoyment for themselves, not of ultimate victory in the war. The fact that marauding leads to concealment of supplies and a total cessation of production is no worry of theirs. The most difficult task is to prevent the troops from abusing and alienating the enemy population; and this can be done only by protecting the civil population from pillage and plunder at all times and in all places. It is impossible to permit foraging to-day in one place and prevent it to-morrow in another. Procuring supplies in an enemy's country should be purely a matter of purchase. It is possible to obtain efficiency in production in no other way.

When large forces are operating upon both sides, as on the Western Front in the late war, the food supplies that can be collected in the theatre of war are not of great importance unless a considerable area

of the enemy's country is occupied, as was the case behind the right wing of the German forces. On the other hand, bodies of 10,000 to 30,000 men, in a war of movement, may obtain a large part of their supplies, even in a relatively poor country, if they use the proper "open sesame" to secure the aid and cooperation of the inhabitants. The master key to the situation in all cases is the current coin in use in the enemy's country.

Troops operating in the enemy's country should be plentifully supplied with money current in the invaded country, as foreign money is well-nigh useless, for obvious reasons. It is not difficult to obtain the enemy's circulating medium, through neutrals, and otherwise, if a little foresight is used. Kinglake relates the difficulties of the British in the Crimea in purchasing supplies, when they were suddenly confronted with the necessity of providing themselves with Russian coin; Scott cashed drafts at a discount of 15 per cent in the City of Mexico itself while the city was still held by the Mexicans; and Wellington organized the professional counterfeiters in his army into a mint and coined English gold into French Napoleons when he entered southern France, using a special mark on all coins so that an adjustment could later be made with the French Government, if it were demanded.

A contribution is a term applied to a tax levied by the invader upon all of the inhabitants of occupied territory. A wise commander uses the proceeds of contributions to pay for supplies obtained by requisition. The amount of contributions levied should be based upon the rates of taxation imposed by the enemy upon his own people. If permanent occupation is contemplated, they should not exceed the current rates of taxation. Under the terms of the Armistice of November 11, 1918, Germany was required to pay and subsist the armies of occupation. This amounted, in effect, to the levying of a contribution upon the whole of Germany. Our high command used the proceeds of this contribution to buy supplies from the Germans in the occupied territory. This was a happy illustration of correct principles of supply.

The levying of contributions and of requisitions are separate and distinct functions, and it is of the utmost importance that they be kept separate and distinct in practical application, just as the collection of taxes in the United States and the purchase of supplies for the army are separate and distinct operations.

When an army forages, it combines in one act the levying of contributions and requisitions. It inflicts the whole burden upon the comparatively small number of the enemy with which the army comes into physical contact. It corrupts and destroys the discipline of the troops, leads to the waste and concealment of supplies, and stops at once any further production in the area where it is employed. Russia is the victim to-day of the practice applied on a grand scale to the home territory of a nation by its own troops and governing classes. Such being its effect when applied by friendly hands in home territory, what must be its effect when applied by a hostile army in enemy territory!

An invader cannot afford for political reasons, to allow the inhabitants of occupied territory to become the objects of the charity of the civilized world. Unrestricted trade between a powerful nation at war and a smaller country brings great prosperity to the smaller country and is of incalculable benefit to the belligerent. This simple, undisputed law of political economy holds good even when the smaller country, like Belgium, is occupied as enemy territory, provided that the

belligerent observes the ordinary precepts of commercial dealings. Commerce knows no enemy. Napoleon's soldiers marched to Eylau in 1807 in overcoats made in England, with whom France had been at war for four years.

Nothing is more difficult in war than to suppress trade with the enemy. Not only is there no reason to suppress such trade within occupied territory but there is every reason to foster and encourage it. The Belgians refused to work, during the German occupation, not because their labor would benefit the enemy, but because they had no assurance that they would enjoy the fruits of their labor, as individuals. Belgium was self-supporting before the war. By proper measures, her manufacturing and food-producing capacity could have been made an asset to Germany; and the Belgians would have promoted the German cause far more effectively than the Luxemburgers, Dutch, and Scandinavians. The difficulties encountered by the Germans in supplying their armies west of the Argonne bring out clearly the great benefit that Germany would have gained by a wiser administration in Belgium.

The brilliant victories of the French Republic and of the Empire were due largely to the use of unpaid requisitions. Likewise, the ephemeral nature of the French conquests was due to the endless requisitions and arbitrary conduct of the French in occupied territory. De Brack says: "I made eight campaigns under the Empire, and always at the advance posts. I never saw, during all that time, a single war commissary; I never consumed a single ration drawn from one of the army magazines."

War supported by pillage does not bring permanent possession, a fact which belies Napoleon's maxim that "war should support war."

The right to requisition should be denied to stragglers and to all but authorized individuals amongst the troops. It is just as much the duty of the commissary to provide rations in the enemy's country as at home or in allied territory; and the gratuitous assistance of the lawless element amongst the soldiery makes the task of the commissary more difficult and leads to waste, pillage, and demoralization.

Requisitions should be avoided if supplies may be purchased; but they are preferable to foraging and the forced collection of supplies by the troops, even though payment be made in all cases. In the enemy's country all transactions with the inhabitants should be reduced to the basis of purchase and sale at remunerative prices, but requisitions in form may be necessary in order to deal with recalcitrant enemies or to justify the well-inclined in the sight of their own people.

In 1870, the German policy varied with localities. They used paid requisitions both in German and French territory. At Orleans, Etampes, and elsewhere they paid ready money and high prices in the open markets and thus secured ample supplies for daily use after all other methods had failed.

Scott's campaign in Mexico, from his landing at Vera Cruz on March 9, 1847, to his capture of the City of Mexico in the following September, is one of the best examples of subsisting an army, and of clothing and equipping it in great measure, from supplies obtained by purchase in the enemy's country. General Scott did not resort to requisitions. By skillful management and a wise policy of conciliation towards the Mexicans and by rigid discipline, he was able to supply his little army by open market purchases. (Justin H. Smith, *The War With Mexico*.)

There have been few armies more lawless in the enemy's country than that commanded by Taylor. He was unwilling to bring offenders before a military court; he endeavored in vain to induce the Mexican magistrates to act in some cases; and he shipped malefactors to New Orleans, where they were turned loose by the civil courts. The result was "perfect immunity," according to the British consul at Matamoras, upon whom an American soldier drew a pistol "because his cane was black."

Scott, on arriving at Tampico, issued a general order which threw the pale of martial law around the American forces operating in México, and provided for punishment by military commission for offenses not covered by the Articles of War. This order, republished at Vera Cruz, Puebla, and the Capital and circulated in Spanish, was supplemented by safeguards. He issued instructions enjoining kind treatment of the people in the strongest possible terms as absolutely necessary if the troops did not wish to starve; and he took effective measures to enforce his own orders. At Vera Cruz a camp follower was promptly hanged for rape. He was inexorable in punishing marauders and foragers. They were flogged, their heads were shaved, and they were drummed out of camp with the word "robber" pasted on their backs.

Scott's first care, after taking Vera Cruz, was to make sure of getting indispensable supplies up to the highlands before the rainy season. His next concern was to gather provisions, determine whether supplies of breadstuffs, meats, rice, beans, coffee, sugar, and forage existed near the proposed line of march, and arrange for obtaining them despite the natural hostility of the people.

He took positive measures to secure the cooperation of the Mexicans, distributed food among the people of Vera Cruz, prevented extortion by fixing a fair schedule of prices, and employed a large force of native laborers at liberal wages to clean the streets of Vera Cruz.

At Jalapa, American generals attended the funeral of a worthy Mexican officer killed at Cerro Gordo. Gold and silver flowed in streams that reached the humblest cottage. Many of the people wept when Scott marched away. Damages were made good, although the Americans found out then, as we later learned in Europe, that many claims for damages were absolutely unfounded or grossly exaggerated.

The Mexican Government ordered that nothing marketable should be taken into the city, when the Americans occupied Puebla; but the Pueblans replied unanswerably "there is no power to enforce that policy and if there were, the result would be to starve us, not the Americans, for they could supply their needs by the sword and we could not." The Americans were offered all sorts of articles at moderate prices.

In occupying towns, officers and soldiers were not billeted without consent upon any inhabitant, and troops were quartered in barracks and other public buildings already used for that purpose by the Mexican Government. These arrangements, the practice of paying for everything used by the army, the principle of treating non-combatant Mexicans as fellow citizens, and a strenuous endeavor to enlist the cooperation of all the decent men of the army in the suppression of outrages, constituted Scott's system.

On June 3d, he decided to throw away the scabbard and meet all odds with the naked sword, and he reluctantly ordered up to Puebla the garrison at Jalapa and part of the men left at Perote, cutting himself off in the heart of the enemy's country.

Scott was always in financial difficulties, but he made every effort to have money in hand to pay for supplies even if the men went unpaid. There were many men at Puebla who had served eight months and had been paid for two. At the same time, shoes and other indispensable clothing had to be obtained in the country, the army was in debt, and credit was fluctuating. The Mexicans knew of Scott's financial difficulties and Scott knew that they knew. Early in August essential clothing had been purchased and manufactured; a large stock of provisions had been accumulated; and, at a cost of 15 per cent., funds for the march to the Capital had been raised. When the army marched, people along the route, who were to have cheated the Americans, recognized the difference between them and the Mexican troops, and the Mexican Irregulars welcomed them cordially, and gave them all possible assistance. A large quantity of provisions contracted for while the Americans lay at Puebla, was brought out and a train of wagons proceeded for the same purpose to the valley of Toluca where a friendly Mexican, ostensibly the implacable enemy of the Americans, helped them to obtain supplies. Apples, pears, and peaches were now ripe and the soldiers lived fairly well.

Almost immediately after entering the Capital, Scott laid an assessment of \$150,000 upon it, and set on foot an examination of the general question of drawing revenues from the country, which eventually showed that nearly 23 millions a year could be collected. He directed that taxes be levied in the district held by the Americans for the support of the American Army; and at the end of December he laid an assessment equal to four times the direct taxes paid in 1843.

Scott's capture of the City of Mexico is the greatest achievement in American military annals. The old general had seen a great deal of fighting and he was a thorough student of his profession. There is internal evidence in his writings that he had thoroughly mastered Voltaire's lives of Charles XII and Louis XIV and Napier's Peninsula War. From these books he imbibed the principles of supply which enabled him to penetrate with his little army nearly 300 miles into the enemy's country.

The administration was imbued with Napoleon's maxim that "war should support war," and had insisted that Scott subsist his army by foraging; but the old hero paid for supplies, punished foragers and marauders, and finally captured the City of Mexico with an army fed by the Mexicans, clothed by the Mexicans, and served by the Mexicans, paid in Mexican money, supplied with much Mexican artillery and ammunition, and assisted by Mexican auxiliary forces raised at Puebla.

At the beginning of the Civil War two generals only, of the whole host of generals, North and South, understood the freedom of movement conferred upon armies by living upon the country: Robert E. Lee had learned it as an officer on Scott's staff in Mexico; and Jackson had acquired it, like Scott, by hard study of military history. The effect can be seen in the Confederate movements in the Antietam and Gettysburg campaigns. It must be admitted that the Federals made a most effective and original use of railways in supplying their troops, particularly in the Gettysburg campaign. The aged General Scott must have read with a peculiar pride Lee's orders for the subsistence of his troops in 1863, which were framed in the spirit of his own orders in Mexico.

The United States Government made the fatal error of deciding the policy of payment upon political grounds. Receipts for supplies were

given which were paid provided the holder could prove loyalty. This amounted, in effect, to confiscation of enemy property. Payment, therefore, served no useful end, except in a few isolated cases, as, for instance, in East Tennessee, where payment to the loyal mountaineers enabled Burnside to live in plenty during the so-called siege of Knoxville. The Confederates made an even greater error. They resorted to what amounted practically to forced requisitions in their own territory and fixed the price of supplies for the Confederacy far below the commercial value. They deserved to see their armies starve in the midst of plenty, an event which came about by a perfectly natural process.

The Federal policy led to the concealment and destruction of supplies, to non-production, and what is worse, to ignorance on the part of Federal commanders of the capabilities of the enemy's country to support armies, and to dependence upon rail communications with the North for all kinds of supplies.

The leaders of the Federal armies were strangely in ignorance as to the capabilities of the country to support armies. Up to the close of 1862 General Grant believed that large bodies of troops must operate from a base of supplies which they always covered and guarded in all forward movements.

In the autumn of 1862, he began preparations to advance against Vicksburg from the north along the railway leading south from western Tennessee. To this end he accumulated great masses of supplies at Holly Springs, in north Mississippi. On December 20, General Van Dorn captured his depot at Holly Springs; and, at the same time, Forrest cut his railway. These things convinced Grant that he could not operate overland, and led him to make the Mississippi river his line of approach to Vicksburg.

After the destruction of his base at Holly Springs, Grant ordered all the forage within reach of his forces to be collected. He states, "the stock was plentiful, but still it gave me no idea of the possibilities of supplying a moving column in an enemy's country from the country itself."

He further states that if he had known the demoralized condition of the enemy who had captured Holly Springs, "or the fact that central Mississippi abounded so in all army supplies, I would have been in pursuit of Pemberton while his cavalry was destroying the roads in my rear. * * * I was amazed at the quantity of supplies the country afforded. It showed me that we could have subsisted off the country for two months instead of two weeks without going beyond the limits designated. This taught me a lesson which was taken advantage of later in the campaign. * * * Our loss of supplies was great at Holly Springs, but it was more than compensated for by those taken from the country and by the lesson taught."

Thus Grant virtually confesses that he would have continued his overland campaign southward from west Tennessee, if he had only known how to live off the country. Where small bodies are operating, the supplies in the country should be the mainstay of the forces. In no other way can that rapidity of movement so essential in war be obtained. It should have been the main reliance of the Union armies in the Civil War, in all theaters, except, perhaps, the main theatre in Virginia. A realization of this fact came to General Grant after the failure of his canal project at Vicksburg. Hence the movement via Grand Gulf to the rear of Vicksburg, when he subsisted his army for 19 days on five days of regularly issued rations.

"Provisions could be taken from the country," said he, "but all the ammunition that can be carried on the person is soon exhausted when there is much fighting. I directed, therefore, immediately on landing, that all the vehicles and draft animals, whether horses, mules, or oxen, in the vicinity, should be collected and loaded to their capacity with ammunition." He had determined to cut loose from his base, destroy the Confederate force in rear of Vicksburg, and invest the city. Even Sherman, who afterwards ignored bases of supply, wrote to General Grant advising him of the impossibility of supplying his army in rear of Vicksburg.

Grant was anxious to utilize his important discovery, after the fall of Vicksburg, and proposed a movement upon Mobile, which would have had all the characteristics of Sherman's march to the sea; but he could not get the approval of higher authority.

Grant's conception of the freedom of movement conferred upon the Union armies by their ability to live off the country is shown by a letter to General Canby written in February, 1865:

"I am in receipt of a dispatch * * * informing me that you have made requisitions for a construction corps and material to build seventy miles of railroad. I have directed that none be sent. Thomas's army has been depleted to send a force to you that they might be where they could act in winter, and at least detain the force the enemy had in the West. If there had been any idea of repairing railroads, it could have been done much better from the North, where we already had the troops. I expected your movements to be cooperative with Sherman's last. This has now entirely failed. I wrote to you long ago, urging you to push promptly and to live upon the country, and destroy railroads, machine shops, etc., not to build them. Take Mobile and hold it, and push your forces to the interior—to Montgomery and to Selma. Destroy railroads, rolling stock, and everything useful for carrying on war, and, when you have done this, take such positions as can be supplied by water. By this means alone you can occupy positions from which the enemy's roads in the interior can be kept broken."

Both Grant and Sherman emphasize the fact in their memoirs that they subsisted their armies from Northern resources and resorted to local supplies only when the Confederates had cut their communications. On April 10, 1864, Sherman wrote: "If the enemy interrupt our communications, I will be absolved of all obligations to subsist on our own resources and will feel perfectly justified in taking whatever and wherever we can find." This indicates a peculiar frame of mind for a commander of an army operating in the enemy's country. That the two leading Federal generals felt called upon to justify their utilization of supplies available in the theatre of war is the strongest condemnation of the supply policy of the United States in the Civil War. Why should such a commander feel under any obligations whatsoever to subsist on his own resources, when enemy resources are close at hand? Why should any justification be needed for subsisting on supplies that can be procured in the enemy's country? What could be more improvident than to carry on war in the midst of plenty with soldiers fed on supplies brought from a great distance? The fatal error consisted in the failure to require that all supplies for the use of the army should be paid for in ready money to the owners regardless of their political affiliations, their loyalty, or disloyalty.

Grant and Sherman were deeply impressed with the importance of destroying supplies which they could not use themselves. Paying for supplies in the enemy's country is not inconsistent with the destruction of railways, factories, and supplies in regions which cannot be brought within your own lines within a reasonable time. But it must be re-

membered as a general principle, that it is far better to make use of the enemy's supplies to defeat his armed forces than to use your own supplies for the purpose of destroying his. The enemy's armed forces under all conditions should be the main objective. The Confederacy was destroyed, not by the supplies which the Union armies consumed and destroyed, but by its poor supply system and by the freedom of movement suddenly acquired by the Union armies, after Grant at Vicksburg and Sherman before Atlanta, had come to realize the use to which the supplies in the country could be put. The worst feature of the unwise Federal policy was the baneful effect that it had upon the minds of the Federal commanders themselves.

The Federal commanders, particularly General Sherman, have passed into history as adepts in the art of utilizing the products of the enemy's country in the prosecution of war. As a matter of fact, they were mere tyros in comparison with Scott, Wellington, and earlier commanders like Charles XII, Gustavus Adolphus, and Henry V. From what has been said, it will be seen that, while the officers of the old regular army at the beginning of the Civil War had studied the tactics of combat, they had not studied what we now call the G-4 (Supply) aspect of war, and had not profited by nor understood the lesson of Scott's advance into Mexico which had been enacted before their eyes.

Our policy of supply should be based upon a judicious system of requisitions and cash purchases in the theatre of operations, combined with a regular flow of supplies along the lines of communications procured at home and from allied and neutral nations. Supplies sent from home and purchased in neutral countries should be supplemented by supplies obtained in occupied territory, just as we supplemented supplies sent to France by supplies purchased in France.

Ammunition, arms, equipment, and replacements must come from the home country; but building materials, food, and forage, should be obtained, as far as practicable, in the theatre of war.

Every encouragement must be given to the people to bring provisions into the camp and severe punishment inflicted upon anyone who interferes with those who furnish supplies to the troops.

Quartering troops upon inhabitants greatly reduces the productive capacity of a region, as the protecting presence of the male element is urgently needed at home.

The advantage of securing supplies in the theatre of operations, in the closest possible proximity to the battle lines, needs no illustration.

No information which can be obtained during a campaign is more valuable than information by districts upon the food supplies of the enemy's country, kinds and amount of crops, harvest season, customs with regard to storage, etc.

The American Army could not have operated in France, except in greatly reduced numbers, but for the products secured in France and the adjoining neutral countries. The problem of how to utilize the local resources of occupied territory differs in degree but not in principle from that which confronted the American forces in friendly French territory. Occupied enemy territory should be treated, from the supply point of view, precisely as so much additional area to the zone of the interior. It ceases to be, economically, a part of the enemy's country and becomes a part of our own economic unit. This is a most important fact which has very practical consequences. If borne in mind by the invaders, it will prevent them from making egregious blunders.

Honorable Mention, Prize Essay Competition, 1922

The Tactical Employment of Antiaircraft Machine Guns

By First Lieutenant Halstead C. Fowler, C. A. C.

INTRODUCTION

S yet, the subject of antiaircraft machine guns has been dealt with but lightly in the pages of the JOURNAL. This is probably due, partly to the fact that the machine gun itself is not a true artillery weapon, and partly to the fact that its importance in use against aircraft has not been fully appreciated. A glance at the records of the use of the machine gun for antiaircraft purposes in the late war, however, will more than justify the continuation in service of the .30 caliber gun, while the recent perfection of the .50 caliber gun places the machine gun foremost among antiaircraft weapons. It is not too much to ask, therefore, that we devote a portion of our time and energy to a study of its use and development.

We of the Coast Artillery have had to undergo many changes in thought due to the tremendous development of our matériel during the recent war. New ideas have been introduced and new principles evolved. It is safe to say, however, that none are so utterly foreign to the pre-war ideas of the Coast Artilleryman as those governing the tactical operation and control of antiaircraft machine guns. To appreciate fully the possibilities of this important arm, the Coast Artilleryman must enter an entirely new field, and must divorce himself completely from all ideas of base lines, azimuth instruments, and the like. In antiaircraft machine gun fire, mechanical control and fire adjustment are sacrificed to obtain speed, mobility and rapidity of fire. Unlike the majority of artillery weapons, the mechanical element is insignificant while the personal element is of prime importance. The accuracy of antiaircraft machine gun fire depends primarily upon the eye and hand of the man pulling the trigger.

MATERIEL USED AND ORGANIZATION OF PERSONNEL

Before taking up the tactics of the antiaircraft machine gun, let us first consider the matériel available, and the organization of the personnel for the proper functioning of that matériel.

MATERIEL

The present weapon of antiaircraft machine gun organizations is the Browning .30 caliber machine gun, model 1917, mounted on the Antiaircraft Tripod, Model 1918. (See Figure 1.)

The gun itself is the best of its caliber and range so far designed and has given most satisfactory results. It is recoil operated, water cooled, and belt fed. It weighs 37 pounds with the water jacket filled, has a maximum range of 2650 yards, and a rate of fire of 500 shots per minute. Its maximum effective antiaircraft range is about 1300 yards.



FIG. 1. .30 CALIBER BROWNING MACHINE GUN, MODEL 1917, MOUNTED ON ANTI-AIRCRAFT TRIPOD, MODEL 1918

The tripod now used is of steel and weighs 60 pounds. The mount, as it stands at present is not entirely satisfactory. It is not sufficiently stable and is difficult to place rapidly in position. A new model, which is of the same general type, but which contains many improvements in design, is now under construction.

The new .50 caliber gun, recently developed, is a tremendous im-

provement over the present weapon. It is of the same type and general construction as the 1917 Browning and has a rate of fire of 550 shots per minute. The maximum range however, is 9000 yards while the range of the weapon now used is but 2650 yards. Its maximum effective antiaircraft range is over 2500 yards as compared with the present range of 1300 yards, and the caliber is such that one hit on the vital part of an airplane at maximum range would be disastrous.

It is a safe prediction that in time the .50 caliber gun will completely supplant the .30 caliber as a weapon for use by antiaircraft machine gun troops. The .30 caliber gun, due to its greater portability, will

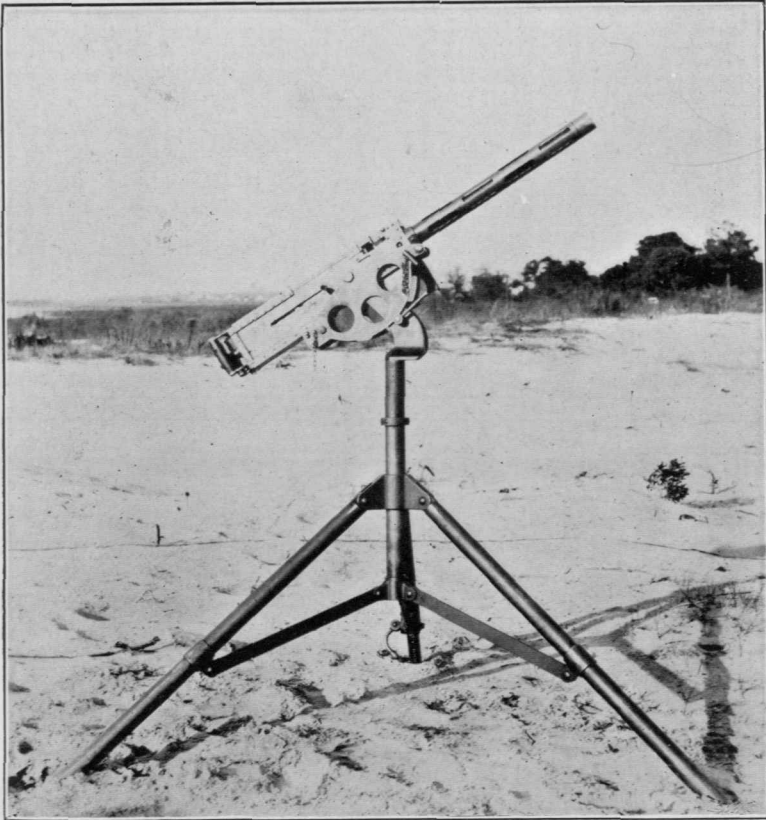

FIG. 2. .50 CALIBER MACHINE GUN MODEL 1921 (AIR COOLED)

still be used as a protective weapon by infantry organizations in the front lines, by heavy, light, and antiaircraft artillery, and also by antiaircraft searchlights. The antiaircraft machine gun organizations armed with the heavy caliber gun of long range, may then be placed in such positions as to enable them not only to give protection to the advance areas of the corps front, but also to the rear areas as well. In a number of cases the guns and searchlights of the regiments will come well within the range of the guns of the machine gun battalion and less individual protection for units will be needed.

Then too, the battalion post of command may be brought farther to the rear where it will be in comparatively close connection with regimental headquarters. In other words, the use of the .50 caliber gun will bring the machine gun battalion into a position where it can be more easily controlled by the regimental commander and where it can protect in a measure the guns and searchlights of the regiment without interfering with its primary mission: i.e., the defense of forward areas of the corps front.

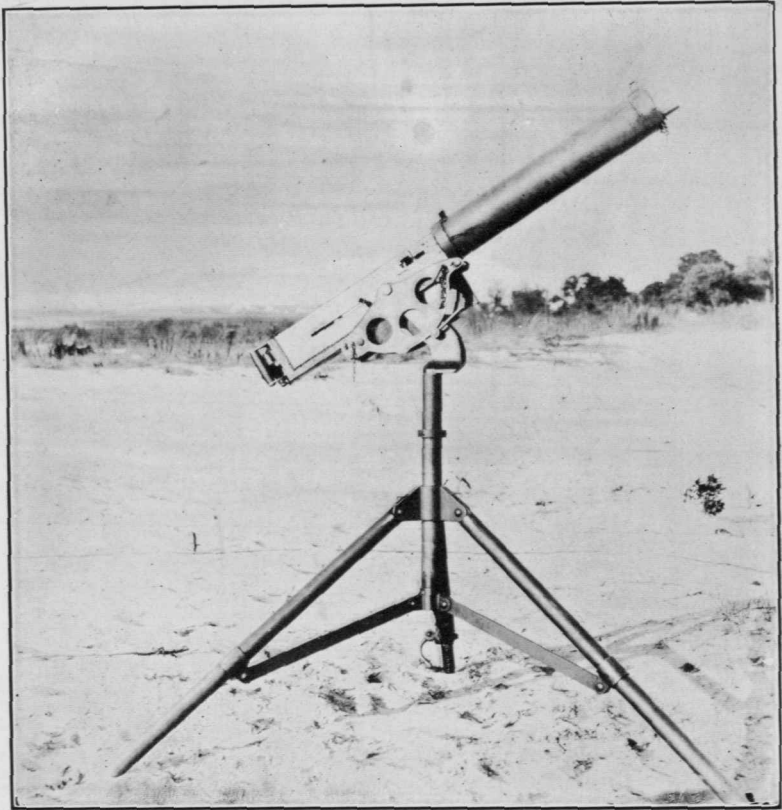

FIG. 3. .50 CALIBER MACHINE GUN, MODEL 1921. (WATER COOLED)

At the present time, however, the .30 caliber gun is still the primary weapon of anti-aircraft machine gun organizations, and so the tactical principles given in this article will relate more particularly to its use. If the .50 caliber gun is adopted as a principal anti-aircraft weapon no radical change in tactics will result. The use of the .50 caliber gun will not materially effect the basic tactical considerations. In general, these will hold good regardless of the type of matériel used.

ORGANIZATION OF PERSONNEL

Anti-aircraft troops are army and corps troops. One anti-aircraft regiment composed of one battalion of anti-aircraft artillery and search-

lights (3 batteries of 4 guns each and 1 searchlight battery of 13 searchlights), and one battalion of anti-aircraft machine guns, is assigned to each Army Corps. One anti-aircraft brigade, consisting of three regiments composed as above, is assigned to each Army.

As has been stated, there is one full machine gun battalion per anti-aircraft regiment. This battalion consists of a battalion headquarters of 3 officers and 28 enlisted men, and 4 companies each of 6 officers and 150 enlisted men. The company is divided into 3 platoons of 1 officer and 40 enlisted men each, and has a company headquarters of 3 officers and 30 enlisted men. The company mans 12 guns, each platoon being divided into 4 gun squads.

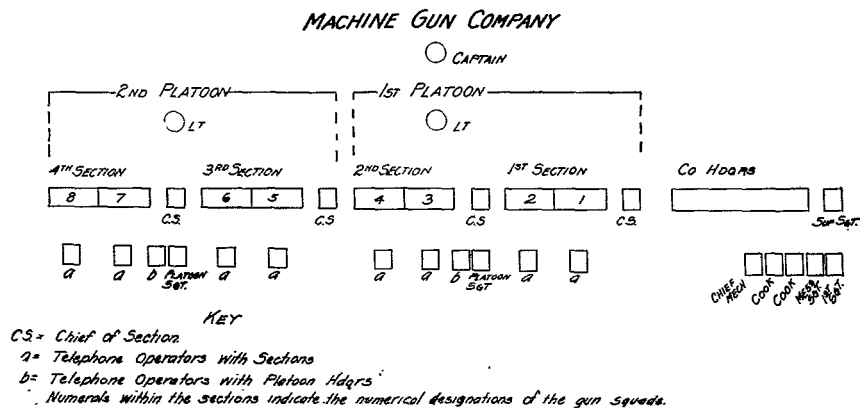

FIG. 4.

For training purposes in peace times, a separate anti-aircraft battalion has been formed. This battalion, if necessary, is capable of being expanded into a war strength anti-aircraft regiment. The machine gun unit of the battalion is 1 company of 3 officers and 76 enlisted men. The company mans 8 guns and is divided into 2 platoons of 32 men and 4 guns each. Full details of the organization can be found in the accompanying table, and formation diagram, Fig. 4.

The gun squad is composed of a corporal and 5 men (war strength 6 men). 2 gun squads form a section, in charge of a non-commissioned officer who is designated as Section Chief. 2 Sections make up a platoon, controlled by a commissioned officer who is the Platoon Leader. He is assisted by a non-commissioned officer who is the Platoon Sergeant. A captain commands the company.

TACTICS

THE MISSION OF ANTI-AIRCRAFT MACHINE GUNS

The *primary* mission of anti-aircraft machine guns is to prevent the close range bombing and machine gunning, by low flying planes, of areas assigned to them.

In forward areas this mission deals principally with the protection of troops, strong points, and forward field artillery positions near the front lines, against attack made by "ground strafing" aircraft.

ORGANIZATION

Machine Gun Company, Antiaircraft Artillery, (Peace Strength 3 Officers, 76 Enlisted Men)

Company Headquarters
(1 Officer, 12 Enlisted men)

Two Platoons
(2 Officers, 64 Enlisted men)

Headquarters Detachment
(1 Officer, 9 Enlisted men)

Communication Detail
(3 Enlisted men)

Each Platoon,
(1 Officer, 32 Enlisted men)

1 Captain	Commanding Company	1 Supply Sgt.	In charge of detail.	<i>Platoon Headquarters</i> (1 Officer, 2 Enlisted men)	<i>Two Sections</i> (30 Enlisted men)
1 1st Sgt.	Assistant in company administration	2 Pvts. or pvts. 1st cl.	In charge of company supplies. In charge of all telephone installation, visual signalling	1 Lieut. Commanding Platoon	For each section: (15 enlisted men) Chief of Section.
1 Mess Sgt.	In charge of company mess.		Telephone operators at company headquarters, switchboard, visual signalmen (Trained as motorcycle drivers)	1 Sgt. Platoon Sgt.	Telephone operators. 1st cl.
1 Chief Mechanic (Pvt. 1st cl.)	In charge of motor transportation and repairs to armament			1 Pvt. or Pvt. 1st cl.	2 squads, (12 enlisted men) For each squad: (6 enlisted men) 1 Cpl. Squad Leader.
3 Pvts. or Pvt. 1st cl.	Chauffeurs, repairmen, drivers of 5-passenger car, two cargo trucks				5 Pvts. Gunners and Pvt. 1st ammuni- cl. tion men.
1 Pvt. or Pvt. 1st cl.	Company Clerk				
2 Pvts. or Pvt. 1st cl.	1 First cook and 1 cook, assistant				

In rear areas the machine guns afford protection against bombing planes which may be flying at a low altitude over their objective.

A *secondary* mission of anti-aircraft machine guns may consist in the protection of anti-aircraft guns and searchlights from observation and attack by hostile aircraft.

An *emergency* mission may also be added, to consist of their employment as an infantry weapon against ground targets.

It must be remembered that the use of anti-aircraft machine guns for the protection of the other anti-aircraft weapons, and as infantry weapons, is subordinate to the primary mission. Anti-aircraft machine guns when handled by trained units constitute in themselves an essential element of any organized system of anti-aircraft defense, and should never be considered as a subordinate or secondary arm. This fact was proven to a marked degree by the record of the 1st and 2nd Anti-aircraft Machine Gun Battalions in France. During two months of front line service with the A. E. F., 41 planes were brought down by these units. In addition to these trained units there were approximately 1500 other anti-aircraft machine guns assigned as a secondary arm with other organizations. These 1500 guns brought down but 2 planes during that entire time.

To obtain the maximum effectiveness from the use of machine guns, the units should be kept intact. Each platoon should be under the tactical control of the company commander, and the companies should, in turn, be coordinated under the battalion commander's direction. To break up trained machine gun units to defend isolated places, or to be used solely for the protection of artillery or searchlight positions, would be disastrous. Artillery and searchlight units should carry machine guns or automatic rifles for their own protection and these should be manned by members of the searchlight or gun crews. The organized machine gun unit should form a separate and distinct element of the anti-aircraft defense system.

FUNCTION OF ANTI-AIRCRAFT MACHINE GUNS IN THE GENERAL SCHEME OF DEFENSE

To quote from the "General Discussion of Anti-aircraft Defense" in the article on the "Tactical Organization and Employment of Anti-aircraft Searchlights" by Major John S. Pratt, in the JOURNAL for August, 1921:

"Anti-aircraft barriers are established as follows:

1. Along the entire front of Armies operating in the field.
2. Around important cities, towns or strong points in the rear areas, which are of limited area and which are of strategic, commercial, or economic importance.
3. Locally, around important industrial (manufacturing) sections of large cities, important isolated manufacturing plants, aerodromes, headquarters, supply, and storage centers, bridges, trestles, and other sensitive points.
4. Around fortified areas on the sea coast for their local security as well as for the various agencies protected by them."

The first consideration mentioned above constitutes what may be called a *front line defense barrier*. The three remaining considerations fall under the term of *rear area barrier rings*. The tactical limitations and possibilities of the various elements of these two defense systems, and the principles governing their coordination and control, have been ably discussed by Major Pratt in his article on Anti-aircraft Defense in the August 1921 issue of the JOURNAL. To avoid needless repetition,

just so much of the general anti-aircraft defense scheme is given, as pertains particularly to the tactics of the machine gun.

The ideal anti-aircraft defense system, as outlined by Major Pratt, consists of a combined defense by pursuit planes, anti-aircraft artillery, machine guns and searchlights, and by captive balloon and kite entanglements in the rear areas.

In the forward areas this defense system, or front line defense barrier, consists of the following parts:

1. A continuous belt of illumination along the entire front to be defended.
2. Gun areas.
3. Airplane areas.
4. A belt of anti-aircraft machine guns extending along the front line positions of the entire defense sector.

The arrangement of this *belt of anti-aircraft machine guns* noted above is such as to give the greatest possible protection to roads, strong points, entrenchments or forward artillery positions, in the vicinity of the front lines, from being bombed and machine gunned by low flying aircraft. It is thus seen that the machine gun belt is the foremost element of the front line defense barrier. Its advance positions are between 500 and 1500 yards of the front line trenches, and communication is maintained with front line listening posts.

The rear area defense system, or rear area barrier ring, consists of the following parts:

1. A continuous belt of illumination about the locality to be defended.
2. Gun areas.
3. Airplane areas.
4. Balloon areas, containing balloon and kite entanglements with auxiliary searchlights, guns, and machine guns if available.
5. A belt of anti-aircraft machine guns extending completely around the area to be defended.

In the rear area barrier ring, the machine gun belt is the innermost element of the defense system. The guns in the belt should be so placed as to form a continuous barrier about the town, locality, or railhead which is to be defended. The arrangement of the belt should also be made with a view to keeping hostile aircraft under fire after they have crossed the machine gun belt and at all times when they are within the barrier ring.

TACTICAL OPERATION

The tactical operation of anti-aircraft machine gun units, and the principles governing the same, will now be considered. In order to obtain a clear cut idea of the entire situation, the battalion, which is the largest tactical unit, will be discussed first. Each of the sub-divisions of the battalion, down to and including the gun squad, will then be considered in turn.

1. FORWARD AREAS

a. *The Battalion*

Although under the regimental commander's direction, the machine gun battalion of an anti-aircraft regiment operates independently of the gun battalion. As has been said before, gun units and searchlight units

should carry machine guns for their own protection and should not, except in cases of extreme necessity, draw upon the machine gun battalion. The battalion commander conducts directly all anti-aircraft machine gun operations within the area assigned to him but should formulate his defense plans so as to conform as closely as practicable with the general defense plans of the regimental commander. The battalion commander is charged with the movement and emplacement of his command. He distributes it so as best to perform his mission, which is the defense of roads, entrenchments, and strong points in the front line from attack by low flying planes.

The battalion having been assigned a sector to defend, the companies are arranged in such a manner as to form a continuous band of fire along the front line of the sector assigned. The machine gun belt should conform generally to the configuration of the front line, having the foremost elements of the belt not less than 300 yards and not more than 1500 yards in rear of the front line positions. In general, the companies forming the machine gun belt should be placed abreast of each other. Whenever possible, companies on the front line should be situated so that the distance between the flank guns of two adjoining companies on the line is not more than 2000 yards. This eliminates dead space and makes it possible for hostile aircraft to be kept under fire continuously along the line. This principle of placing companies abreast of each other, however, depends entirely upon the features of the situation arising, and does not preclude the battalion commander increasing the depth of the belt in places for the protection of important points. It may be said, therefore, that the machine gun belt, while conforming to the front line, may be of varying depth (from one to four companies,) depending upon the extent of front covered by the battalion and the location of important points to be defended.

The battalion command post is situated in rear of the center of the machine gun belt. Communication is maintained with each of the companies composing the belt, the anti-aircraft regimental commander, the anti-aircraft artillery battalion commander, the most advanced searchlight groups, certain selected front line listening posts, and with anti-aircraft machine gun units which may be situated on the flanks of the sector.

Regimental headquarters being in liaison with the infantry and artillery forces in the sector, all orders for the movement of the battalion as a whole should come from that source. This is not an iron bound rule, however, and should the battalion commander find it necessary to move without delay, he should do so and report his action to regimental headquarters. Orders for movement should be transmitted from battalion headquarters to the companies in the belt in such a manner as to have the belt follow, as nearly as possible, the advance or retreat of the front line troops.

b. *The Company*

Upon arriving in the zone of action, the company commander is assigned a defense sector by the battalion commander. He then distributes his company, assigning definite defense sectors to his platoons, so as best to allow him to carry out the mission given him by the battalion commander.

Whenever conditions in the sector will permit, the company is usually placed so that the two flank platoons occupy a forward position abreast

of each other, while the center platoon is to the rear of the center of the interval between the flank platoons. This allows the company commander to strengthen, if need be, his front line guns by drawing from the rear platoon. The rear platoon, however, should be in a position to open fire at once, should a target present itself or should its fire be needed from the original location. It is often advisable to put three platoons in the front line and to have none in rear. When the rear platoon is used, however, a second barrier is established in rear of the first, giving additional depth to the front line defense and decreasing the chances of hostile planes making a successful break through the barrier.

DIAGRAM OF COMMUNICATIONS MACHINE GUN COMPANY

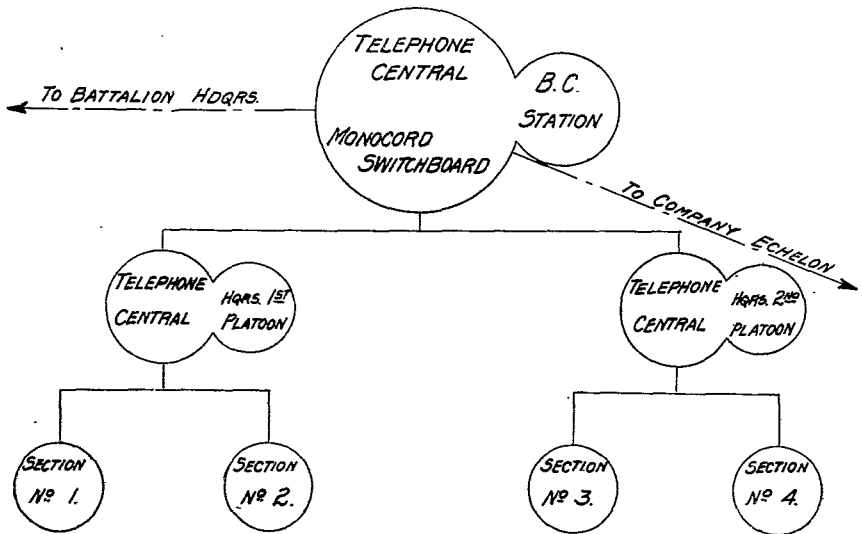

FIG. 5.

Following out the idea of a second barrier in rear of the first, it has been found that when companies are abreast of each other, their platoons may best be arranged with one company having two platoons forward and one in rear and the adjoining company having one platoon forward and two in rear. If there are more companies in the line, the third will have two platoons forward and one in rear, the fourth will have one forward and two in rear, and so on throughout the line.

The distance between platoons primarily depends upon the special situation, namely: features of the terrain, mission to be accomplished, material available, etc. As a general rule, platoons on the front line should not be placed so that the guns of their adjoining flanks are more than 2000 yards apart. The rear platoon should be situated in the approximate center of the interval between the front line platoons and not more than 2000 yards to the rear.

The company post of command is situated at a convenient distance from the three platoons. Whenever possible, a position is selected so that the company commander is able to see the field of fire of all of his

platoons. In cases when it is impossible to get such a position, additional observers should be stationed to cover the unseen portions of the field of fire. They should be equipped with telephones and should be in communication with company headquarters. The company commander should be in communication with each of his platoons and with battalion headquarters. If the situation warrants, he may keep in touch with advance listening posts in the sector and with antiaircraft machine gun companies on his flanks.

The company commander is charged with the movement and emplacement of his command, and with a general supervision of fire. Receiving his mission from battalion headquarters and keeping this clearly in mind, he should assign defense sectors to his platoons and designate their missions accordingly. Except in extremely rare cases, he should never attempt to control directly the fire of his entire company. The distances between units are too great, and the time during which the targets are visible is too short, to permit of the control of fire by the company commander. Fire control should be exercised directly by the platoon commanders and section chiefs, under the general supervision of the company commander.

c. *The Platoon*

The platoon commander first divides the sector assigned to him by the company commander, in such a manner that it is completely covered by the fields of fire of his two sections. He should designate to his section chiefs the general location for the guns of each section and should give any instructions as to emplacing, camouflage, etc., that he may deem necessary.

Except in cases where the defense area is extremely narrow, the sections are placed abreast of each other. Generally the distance between sections, (measured between the guns on the adjoining flanks of the sections,) should not be over 1000 yards.

The platoon post of command should be situated in rear of the center of the interval between sections. A position should be chosen, whenever possible, from which the platoon commander can see throughout the fields of fire of both of the sections. When this is impossible, the platoon commander should, as in the case of the company commander, station observers equipped with telephones in such positions as will enable him to cover the parts of his platoon front that he is unable to see.

As soon as possible after arriving at a position, the platoon commander should divide the fields of fire of his sections into subareas, naming them after localities or permanent land marks. This will enable him to designate targets with rapidity and precision. The section chiefs should thoroughly understand the limits of the various subareas and should be cautioned to use them when designating targets to the guns of their sections. In assigning targets the platoon leader should give his commands as follows:

TARGET, subarea (Buckroe, Verdun)

Description of planes, formation.

Direction, (Coming over, passing right, flying south)

ALTITUDE or RANGE (Depending upon the type of sight used)

COMMENCE FIRING or FIRE WHEN IN RANGE.

In all cases where the platoon commander designates the targets and exercises fire control over both of his sections, he should give his

commands as soon as possible after the target is first seen. This should give the gunners plenty of opportunity to open fire on the target as soon it comes within range.

There are a number of instances when the platoon commander will be unable to control directly the fire of his platoons. In many cases, enemy planes will appear so quickly and will be moving so rapidly that it will be impossible for the platoon commander to designate targets to his sections. The section chiefs should then direct the fire of their sections and should report the results of their action to platoon headquarters. It is essential that hostile aircraft be engaged as soon as they come within range. To wait for a designation of target by the platoon commander will, in many instances, result in the loss of much valuable time and may prevent the sections from firing on the target at all. It is therefore advisable under conditions such as this, to have the section chiefs open fire at their own discretion, reporting their action to platoon headquarters. This should not be taken to preclude the platoon commander assigning and designating targets in all cases where it is possible for him to do so before they come within range of the guns.

The platoon commander should keep a careful check on the ammunition expenditure and should assure himself of the proper functioning of the ammunition supply system. It is essential that an adequate supply of ammunition be at hand at all times.

Telephonic communication is maintained between the platoon commander and company headquarters. Whenever possible the platoon commander should connect with some listening post in the front line, with a view to gaining any advance information of hostile attacks, movements of friendly troops, or general conditions on the front lines. Except in cases of emergency, all orders for movement should come from company headquarters.

The platoon commander should make frequent reports on the results of the action of his platoon, the condition of his supply of ammunition, and information of the enemy, to the company commander. Should the telephonic communication fail at any time, liaison with company headquarters and the sections should be kept up by means of runners.

d. *The Section*

The section is the smallest tactical unit of the antiaircraft machine gun organization. The non-commissioned officer in charge of a section, (section chief,) has under his supervision two guns manned by the necessary personnel, and is charged with their movement, emplacement, and fire control. Since antiaircraft machine guns should, except in cases of extreme necessity, always be mounted in pairs, a section is never divided.

The section chief is responsible for the discipline of the men of his section and for the proper performance of duty by them. The section should be drilled to maneuver as a section. It should be able to go in or out of action with rapidity and ease. Numerous field exercises should be held to familiarize the men with service conditions and action under the direction of the section chief.

Upon arriving at a position, the section chief should receive from the platoon commander an assignment of his section defense sector and should be informed as to the names and limits of its subareas. After receiving this information he should communicate it to the corporals of his gun squads and should then select the positions of his

guns. The following considerations should govern the action of section chiefs in the selection of positions:

1. Field of Fire

a. **Traverse:** The guns of the section should be so placed that they will have sufficient field of fire to enable them to carry out the mission assigned to them by the platoon commander. In other words, both guns should completely cover the sector assigned to the section. Any additional amount of traverse which may be obtained is not objectionable.

b. **Elevation:** It has been determined as a result of continued firings, that firing at aircraft, using the .30 caliber gun, at an angle of elevation of less than 8° is a useless expenditure of ammunition and also is dangerous to friendly troops which may be in advanced positions in front of the guns. The gun positions should therefore be selected so that the gunner may sight on a target at all angles of elevation from 8° to 90° throughout the field of fire.

2. Cover and Protection

When actually firing the guns it is practically impossible to have overhead protection and cover for the gun itself. This would hinder the gunner, and would prevent him from firing on targets at high angles of elevation. When not in use, the gun may be camouflaged by means of brush and leaves placed on wire netting and this arrangement put over the gun. The belt filling station, ammunition routes, and telephone operators should be concealed from view as much as possible. This concealment may be obtained by locating the guns on the edge of a wood or near underbrush, where the belt filling station, etc., may be set up within the woods or underbrush. A position in a corn field or in a cane brake also offers possibilities for good cover and protection. If time is available dugouts may be constructed for the belt filling station and telephone operators.

The section post of command should be chosen as soon as the gun positions have been determined upon. It should be so placed that the section chief may view the entire field of fire of his section and may be able to control his guns by word of mouth or by arm or whistle signals. He may have his telephone operator with him or under cover, slightly to the rear.

The position of section chief is a highly important one. Initiative, ability to lead, force, and a thorough knowledge of the tactical limits and possibilities of the arm should characterize the men selected to control the sections. While whenever possible the designation of targets will come from the platoon commander, there will be a number of cases when the fire control of the section will rest wholly with the section chief. He should therefore be able to designate and assign targets with rapidity and ease. He should be an expert in the identification of aircraft and in the estimation of ranges, altitudes, and speeds.

The section chief is in telephonic communication with the platoon post of command, and all orders for movement should come from that source. The section chief should keep the platoon commander informed on the results of the action of his section, the condition of his ammunition supply, and the general tactical situation.

e. *The Gun Squad*

The personnel of the gun squad consists of a corporal and 6 men, numbered from 1 to 6. The squad is charged with the movement, emplacement, and proper functioning of one gun. The corporal is in immediate charge of the squad and is responsible for the proper performance of duty by its members.

The equipment of the squad consists of the gun, the tripod, a tool box containing spare parts, water can and condensing tube, four boxes of ammunition and the belt filling machine. In addition to the above, the following intrenching equipment is carried by the men:

Corporal	Wire cutter
No. 1	Hand axe.
Nos. 2 and 3	Intrenching pick.
Nos. 4, 5, and 6	Intrenching shovel.



FIG. 6. .30 CALIBER MACHINE GUN IN ACTION. SHOWING POSITION OF GUN CREW

The corporal commands the squad, No. 1 is the gunner, No. 2 the loader and assistant gunner, No. 3 and No. 4 are ammunition men, No. 5 and No. 6 are in charge of the belt filling station.

The gun squad should be carefully drilled in the service of the piece, keeping two objects in view—one, to develop in the men, speed in handling the gun and motions that are distinct and accurate; the other, to develop discipline. Every man in the squad is thoroughly trained in the duties of every other man. The best men should be chosen for the various positions, but other men should be available to replace anyone who becomes a casualty. Service firings should be continued throughout the year. This allows the men to become accustomed to handling the gun under service conditions, and enables the gunners to be kept efficiently trained.

Upon moving into position, the corporal receives a designation of his gun position from the section chief. If the section chief has been properly trained and has used good judgment, this position will afford the best field of fire available and will offer every advantage possible in natural camouflage.

The corporal then moves his squad into position, and whenever time permits will construct an emplacement for the gun. The character of

the emplacement varies, according to the amount of time available, from merely a hole dug in the ground to a carefully revetted and sand-bagged gun position. In a sector in which the movement of troops is rapid, there is usually no time to be spared in the construction of emplacements. In these cases, shell holes, abandoned trenches, and the like, often offer advantages for use as a gun emplacement. When these are not to be had, positions that offer the best natural cover, in the form of neck-high underbrush, edges of woods, corn fields, etc., should be used. This latter consideration should, however, be more properly thought of in connection with the selection of positions, which should be left to the section chief. It is the especial duty of the squad leader to improve, as much as possible, in field of fire, cover and protection, the position assigned to him by the section chief.



FIG. 7. BELT FILLING STATION, SHOWING NO. 5 AND NO. 6 OPERATING BELT FILLING MACHINE

So much for a situation in which conditions are changing rapidly. Except in the case of a very rapid advance or a precipitate retreat, the operation will be one of slower movement, and more time will be available for the construction of gun emplacements.

The usual form of gun emplacement consists of three parts, viz.: the gun emplacement proper, the ammunition supply trench, and the belt filling station.

The gun emplacement proper consists of a circular hole about 6 feet deep and large enough to permit the gun to be easily maneuvered throughout the field of fire by a crew of two men. It should be wide enough to allow the corporal also to move about in the emplacement when necessary. Generally the diameter is from 7 to 10 feet. (See Figure 8 and the Frontispiece.)

Running from the gun emplacement to the belt filling station (situated 50 yards in rear) is the ammunition supply trench. This is simply a trench dug to a depth of from 4 to 6 feet and wide enough for two men to pass each other at any point throughout its length. Although not necessary, it is often desirable to widen the trench at a point halfway between the belt filling station and the gun. This will aid No. 4 of the gun squad in exchanging filled and empty ammunition boxes.

Situated about 50 yards in rear of the gun emplacement is the belt filling station. The station consists of the belt filling machine, ammunition, ammunition boxes and belts, and is operated by No. 5 and No. 6 of the gun squad. To afford the maximum protection for the operating personnel and the supply system, a pit may be dug for the

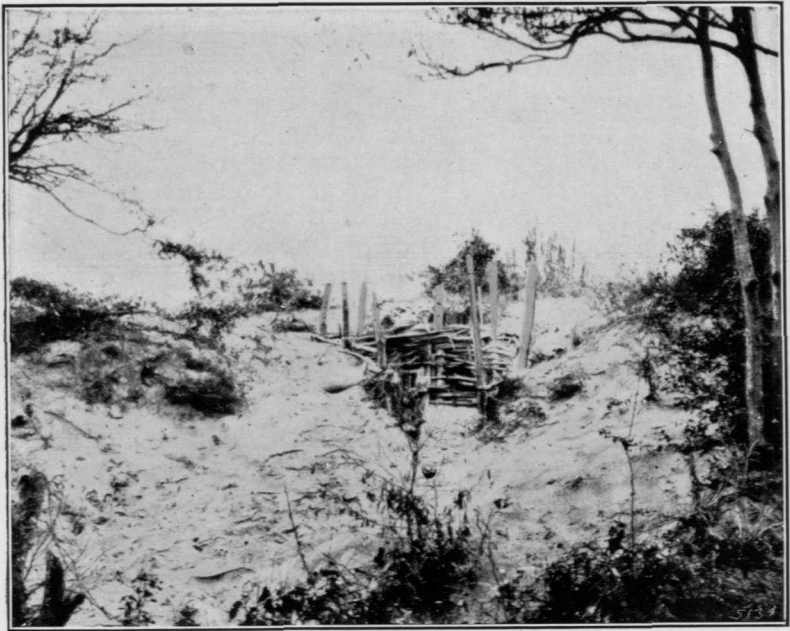

FIG. 8. TYPICAL FORWARD AREA ANTI-AIRCRAFT MACHINE GUN EMPLACEMENT

belt filling station. The pit should be from 4 to 6 feet deep and of such size as to enable the belt filling apparatus to be operated easily.

The entire position,—gun emplacement, supply trench, and belt filling station—should be as carefully camouflaged as time will permit. If possible the sides of the position should be reinforced with sandbags and revetted with saplings, boards, or corrugated iron. If the position taken up is on low ground the bottom may be floored. The camouflage should be as complete as possible, taking every advantage of all the natural features of the terrain available. Grass, tree branches, shrubs, etc., may be arranged about the position taking care that they are made to appear as natural as possible. Before carrying out any bombardment, reconnaissance planes fly over to identify positions if possible, and to take photographs. Any change in the general aspect of the sector, if not properly concealed, is revealed on the photograph. Great

care must therefore be taken in order that the terrain may look unchanged. If the enemy is at all observant, most of the work must be done at night. A screen of wire netting covered with leaves, grass, etc., should always be convenient so that the emplacement may be covered when work is suspended. Another camouflage idea used in machine gun emplacements, is to make the position appear as an old shell hole. In this case the ammunition supply trench may be done away with, and the gun emplacement made in one shell hole, with the belt filling station in another. Care must be taken to make the general appearance of the position as natural as possible.

Camouflage discipline must be rigidly enforced in the squad. Old established paths should be used whenever possible. If a new path is made it should be continued some two or three hundred yards beyond the position, or should be made to join some other path, in order that trace may be lost. The men of the squad should be carefully instructed in the reasons and necessity for camouflage and in the preservation and maintainance of adequate concealment.

As has been stated, the corporal has immediate charge of the making of the emplacement. He is responsible for the proper construction, and camouflage of the position and for the enforcement of camouflage discipline in the squad.

He should also supervise the preparation of the gun for action. After satisfying himself that his squad is ready for an immediate opening of fire he reports to the section chief.—“NO. — IN ORDER.” Should a stoppage occur and his gun go out of action, he immediately reports, “NO. — OUT OF ACTION.” with an estimate of the time necessary to put it in order again. During the firing he supervises, generally, the work of the squad, checking the aim of No. 1, and noting particularly the functioning of the ammunition supply system. In case of casualties he should see that the men are replaced and that the work of the squad is continued with as little confusion as possible.

2. REAR AREAS

“The same general tactical principles are observed in establishing anti-aircraft barrier rings in the rear areas as are followed in the organization of a continuous barrier along the front of an Army or Group of Armies. The principal differences existing between the two situations may be stated as follows:

1. Barriers in rear areas usually extend completely around a particular area which is to be protected against attack from the air.

2. The various constituent elements of the barrier rarely if ever will be subjected to artillery fire or to terrestrial observation; therefore considerably more latitude may be granted in determining their exact locations.

3. The barrier is fixed in position and does not have to conform to troop movements. * * * Mobility may be sacrificed for accuracy and precision with less disadvantage to the defense.

4. The personnel usually enjoys protracted periods of rest and is not subjected to the nerve-racking strains of continuous campaigning. Troops of an inferior general physique may be used if the economic situation requires.

* * * * *

7. The defense usually receives warning of an attack considerably in advance of the time it actually occurs.” (Major John S. Pratt, C. A. C., in the JOURNAL for August, 1921.)

It is seen by the above that most of the statements made in reference to forward areas will apply equally well to rear area defenses. There are some differences, however, which occur, and these will be noted in the following paragraphs.

In establishing rear area barrier rings, the units or groups of units designated to compose the machine gun belt, may be more or less than a battalion. In the following discussion, believing that it is best to keep units intact if possible, it has been assumed that a battalion composes the machine gun belt. It must be remembered that this is not always the case.

a. *The Battalion*

The duties and responsibilities of the battalion commander in the rear areas are essentially the same as in the forward area operations. The battalion is usually given a definite objective instead of a sector to defend, and the companies should be placed so as to afford the maximum possible protection to this objective. The principles governing the distances between companies in barrier ring are the same as those given for companies in the forward areas. It is necessary, when establishing the machine gun belt of a rear area barrier ring, to distribute the companies in depth and breadth in such a manner as to insure that hostile aircraft may be kept under fire even though they break through the barrier and fly over their objective. For this purpose machine guns are often placed on the roofs of buildings within the locality that is being defended.

The battalion post of command is situated somewhere near the center of the machine gun belt. The battalion commander is in communication with each of the companies composing the belt, the regimental commander, and the antiaircraft artillery battalion commander.

b. *The Company*

In general, the tactics of the company in the rear area barrier ring are the same as those in the forward areas. The platoons are distributed in the same manner as in the forward areas, keeping in mind that it should be possible to engage hostile planes at all times when they are near their objective.

c. *The Platoon*

No radical change occurs in the tactical principles governing the platoon when it becomes a part of the rear area barrier ring.

d. *The Section*

In selecting the positions for the guns of a section that is acting in a rear area barrier ring, three things must be borne in mind. They are:

1. That it will usually be necessary to fire to the rear of the position as well as to the front. Hence, as a general rule a field of fire of 360° is needed.

2. That the danger resulting from artillery and rifle fire is much less than in the forward areas. Terrestrial observation is also infrequent. Therefore, less care may be taken in the consideration of cover for a position, and more in the consideration of the field of fire available.

3. That the positions selected will be of a permanent or semi-permanent nature. More time will be available for their construction and greater care can be taken in constructing them.

After selecting his gun positions, the section chief informs the corporals who supervise the construction of the emplacements. The duties of the section chief are no different from those in the forward areas.

e. *The Gun Squad*

The positions constructed in the rear areas should follow the same general form as prescribed for forward area defenses. The sides of position should be sandbagged and revetted and the bottom floored if necessary.

If time is available and the area to be defended is subject to frequent bombing, dugouts for both personnel and ammunition should be constructed.



Recent Developments in Antiaircraft Matériel

By Captain Aaron Bradshaw, Jr., C. A. C.



CONSIDERABLE study has been given to the possibilities of developing more efficient Antiaircraft Matériel. The World War and the progress and growth in importance of aircraft since the War proved the need for developments along this line. The science of antiaircraft defense was born with the World War and still remains in its infancy but the importance and need for great and far reaching developments can not be denied. The necessity for protecting ourselves in the future against hostile armies in the air is today a thought for the nation.

The experiences of the World War have well defined the paths that developments should follow. We have come to know that some of the urgent needs of this great service are as follows:

(1) The production of a machine gun of great destructive power and with an effective range of from 2000-3000 yards against aerial targets.

(2) The production of guns which will greatly reduce the time of flight of the projectile, increase the rate of fire, and give us an increase in the volume of effective explosion placed in a unit of space in a given unit of time.

(3) The development of a Monostatic Height Finder.

(4) The development of a Clockwork or Mechanical Fuse.

(5) The development of a centralized data computing machine or machines.

(6) The development of a practical sound locating device.

It is the purpose of this paper to discuss the known progress that is being made to solve the problems above enumerated and to give a few of the details of the solutions in the hope that others will be interested and further developments result.

THE BROWNING .50 CALIBER MACHINE GUN

Antiaircraft Artillery has not proved very effective against low flying aircraft because aircraft flying low offer a target which is difficult to track, unless it is at a great distance, due to its rapidly changing angle of travel. Machine guns when properly employed have proved to be effective weapons against aircraft flying low, and their success in the World War has dictated the necessity for their use in the future. But the experiences of the World War taught that the effective range of the present .30 caliber machine guns was too short and that the destructive power of the ammunition was not great enough, even when employing incendiary ammunition.

Realizing this need for a high powered gun of longer range than the .30 caliber, Mr. Browning, the designer of our service .30 caliber machine gun, submitted a water cooled gun of .50 caliber, and it was completed

in the summer of 1918. This gun after some modifications and improvements by the Ordnance Department was finally perfected and offered to the service in three types or models as follows:

- (1) A water cooled type for use on the ground against ground targets.
- (2) An air cooled type for use on the ground against aircraft and in tanks.
- (3) An air cooled type for mounting in airplanes.

The preliminary service tests for the .50 caliber machine guns for antiaircraft were held by the 61st Artillery Battalion (AA) at Fort Monroe, Virginia, and in accordance with the above plan a gun of the air cooled type for use against aircraft and in tanks, was sent there. (See Figure 2 of the preceding article in this issue.)

It was quickly shown that this air cooled type would not satisfy the needs for antiaircraft work, as continuous fire, which is a prime requirement, is not possible with any type of air cooled gun thus far developed, due to excessive resulting heat.

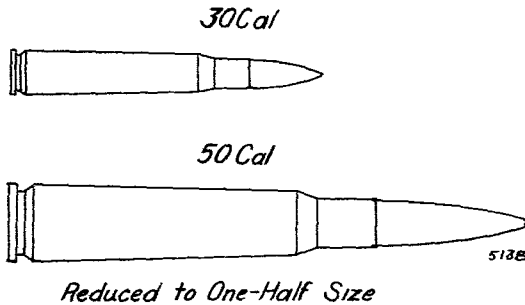

FIG. 1.

The second gun sent to Fort Monroe for service tests was a water cooled gun, of which a brief description follows. (See Figure 3 of the preceding article in this issue.) The Browning .50 Caliber Machine Gun is recoil operated and the principles of operation are practically the same as those of the Browning .30 Caliber Machine Gun. The minor defects of the .30 caliber gun were corrected in the .50 caliber gun and some additional improvements made, the principal one of which, is the addition of a hydraulic buffer to absorb the energy of recoil. This .50 caliber gun is belt fed and fires approximately 550 shots per minute and is capable of firing 300 rounds continuously before the water reaches the boiling point. The water cooled gun weighs approximately 66 pounds without water and 82 pounds with the water jacket filled. The capacity of the water jacket is about eight quarts. This gun imparts a muzzle velocity of 2500 feet per second to an 804 grain bullet and has a maximum range of 9000 yards with an effective range against aircraft of approximately 3000 yards (estimated) and it is believed at this range one hit on a vital part would destroy a plane. A comparison of the relative size of the 50 caliber and 30 caliber bullets can be seen by referring to Figure 1.

The tripod furnished with this gun is the Experimental Tripod Model 1921. It is a center pintle tripod with universal motion. It will elevate from -15° to $+90^{\circ}$ and has 360° traverse. The three legs of

steel tubing are bolted about a center post made of sectional steel columns. The legs are equipped with steel shoes 3 inches in diameter. It also has elevation and traversing friction locks. The total weight of the tripod assembled is 132 pounds, but it can be broken up readily into two sections, the tripod proper weighing 100 pounds and the cradle weighing 32 pounds.

In the preliminary service tests held, the gun functioned very satisfactorily as an anti-aircraft weapon. Some minor modifications in design such as changing the balance of the gun, lengthening the barrel, and equipping it with a flash hider have been suggested. Shoulder stocks have been used with the gun while firing with a resultant increase in the ease of maneuver and accuracy of fire. The gun when finally perfected will be an anti-aircraft weapon of high efficiency.

Successful preliminary tests of the tripod (Experimental Model 1921) have also been held. The tripod is of such design as to permit rapid and easy maneuver, and its weight is within the carrying capacity of two men.

It is intended to furnish .50 caliber ammunition in four types, namely: service or ball, tracer, incendiary and armor piercing, and experiments are being conducted by the Ordnance Department with this end in view. Due to the high cost of manufacture, it is the intention to furnish only service and tracer ammunition for use during peace time, reserving the incendiary and armor piercing ammunition for issue during a period of hostilities. At the present time, only the service ammunition has been developed satisfactorily. The tracer ammunition is still in the experimental stage. When perfected it is hoped to obtain a tracer with a visible length of flight of 3,000 yards or more.

Experiments are also being conducted with a view to developing an efficient aircraft machine gun sight for use with the .50 caliber gun. It is hoped to obtain a type of sight capable of being used with equal facility and accuracy in both forward areas and rear areas.

An attempt is also being made to obtain sight mechanism of standard design, which may be generally followed in the construction of a sight for the .30 caliber gun as well as for the .50 caliber.

At this point it may be well to consider the future of automatic rifles with which anti-aircraft units are now supplied. It is believed that the Automatic Rifle has no place in any anti-aircraft unit.

In engaging aircraft with small arms continuity of fire is of prime importance. If interrupted firing is used there is great danger of a break in fire occurring just when the most damage might be inflicted. As now designed, the Automatic Rifle permits of but 40 rounds continuous fire. This is hardly enough even to allow the gunner to adjust his fire on the target, to say nothing of permitting an effective fire to be delivered. It is believed, therefore, that the .30 caliber machine gun should supplant the automatic rifle, as a protective weapon for anti-aircraft organizations.

ANTI-AIRCRAFT GUNS

The means employed in an anti-aircraft defense, are generally grouped under headings:

- (1) Active Defense.
- (2) Passive Defense.

The means available in an active defense in order of importance are:

- (1) Aircraft equipped with offensive weapons.
- (2) Antiaircraft Artillery on the ground.
- (3) Machine Guns on the ground.
- (4) Searchlights.

The means available for passive defense are aerial obstacles such as captive balloons, smoke screens, employment of false areas and the use of confusing dispositions of lights.

The importance of passive defense is questionable and the results obtained by this means in the World War are in doubt. To combat successfully a determined enemy, the resistance must be active. At best the effects of passive defense are moral effects.

It is generally admitted that the most efficient weapon for combating enemy aircraft is our own aircraft, provided that there can be concentrated quickly a sufficient number of our own planes to give us supremacy at the proper time and at the right place along the path of the attack. But this problem of concentrating quickly aircraft at points along the path of the attack at high altitudes, is a difficult one and it serves as a warning to the enemy. The concentration of aircraft requires considerable time, for high altitudes can not at present be gained quickly. The antiaircraft gun can come into action without delay.

The excessive cost of maintaining a great volume of aircraft for concentration along the paths of attack and the difficulties attending such concentrations have accentuated the need for effective Antiaircraft Artillery and its accompanying machine guns and searchlights.

The necessity for antiaircraft artillery has been proved, for it is impossible to maintain supremacy in the air so that a determined enemy can not successfully make many of the raids that it desires.

The development of a gun that satisfies the needs for combating aircraft is a difficult problem. It must satisfy the following general requirements:

- (1) A rapid rate of fire
- (2) A large volume of effective explosive
- (3) Minimum time of flight for projectile (High muzzle velocity)
- (4) All around traverse (360°)
- (5) Elevation up to 80° .

The question of lowering the maximum limit of the elevation to 70° has been discussed much of late. The adoption of such a maximum limit of elevation would greatly simplify the work of the designer, but such a change is not believed advisable. The question of great stability was not seriously considered in the general requirements but such a consideration would be of prime importance if the sighting system was anything other than an indirect one. An unstable gun keeps the gun pointers (direct system) from following the targets continuously, a prime requirement.

The Ordnance Department during the War developed three guns:

(1) U. S. 3-in. A.A. Gun, Fixed Pedestal Mount, Model of 1917 (Converted Seacoast) M.V. 2600 f, s, Semi-automatic breech block, 360° traverse, 0 to 85° elevation, Maximum horizontal range 12,750 yards.

(2) U. S. 75-mm Gun, Model of 1916, Mounted on A.A. Self Propelled Truck, Model of 1917, M.V. 1800 f, s, range at maximum elevation 7000 meters, limits of elevation 31° to 85° , 240° traverse, semi-automatic breech block.

(3) U.S. 3-in. Trailer Mount; 3-in. Gun, Model of 1918 on a 3-in. Trailer Carriage Model 1917, drawn by F.W.D. truck; M.V. 2400 f/s, range at maximum elevation 7500 M. Limits of elevation 10° to 85° ; 360° traverse; semi-automatic breech block.

The Fixed Mount, No. 1 above, with the exception of the sighting mechanism is an efficient weapon, but the 75-mm Truck Mount and 3-in. Trailer Mount are not satisfactory. The general criticism of both guns is that the sighting mechanisms are improperly designed, as are the elevating and traversing mechanism, which means that a fast moving target can not be tracked satisfactorily. The 3-in. Trailer Mount also is very unsteady during firing, loading at high angles of elevation is impracticable and its counter recoil mechanism does not function regularly. The 75-mm Truck Mount is a gun of very low muzzle velocity, has 120° dead space in traverse, is unsteady during firing, has a minimum elevation of 31° and is very difficult to emplace.

Thus at the end of the late war we had no efficient mobile gun for antiaircraft work. A study of the various guns and mounts used during the war led to the belief that two types of guns were necessary, a light gun of about 75-mm and a heavy gun of about 105-mm. The ideal guns should develop an initial muzzle velocity of about 1000 m/s. The ideal of each type for our service has been given out by our Ordnance Department as follows:

(1) Heavy Gun 4.7-inch or larger, M.V. 2600 f/s; 45 pound or heavier projectile; pneumatic loading device; 80° elevation, 360° traverse; fixed ammunition; H.E. Shell; Mechanical Fuse.

(2) Light Gun 3-inch; other requirements same as for Heavy Gun except projectile to be 15 pounds or heavier.

The mount for the 3-inch to be a self propelled caterpillar, or caterpillar trailer. The mount for the 4.7-inch to be a self propelled caterpillar.

With the requirements as stated above as a guide, our Ordnance Department has designed and built the pilot Models of two guns, a 3-in. A.A. Gun, and, a 4.7-in. A.A. Gun which possess the following characteristics:

3-INCH A.A. GUN, MOTOR CARRIAGE MOUNT, MODEL 1920 E

- (1) Muzzle velocity 2600 f/s
- (2) Maximum Horizontal Range 17,800 yards.
- (3) All around fire
- (4) Elevation from minus 5° to plus 80°
- (5) Operation by either a direct or an indirect fire control system
- (6) Pneumatic loading device

4.7-INCH A.A. GUN

- (1) Maximum horizontal range, 20,250 yards
- (2) Other characteristics same as for 3-inch A.A. Gun, making this gun really the 3-inch, built upon a larger scale. It fires a 45 pound projectile.

The design of this mount, with its built-up cradle, presents many novel features and is quite different from other American Mounts. Some of the special equipment includes pneumatic loading device, semi-automatic breech opening mechanism, special design of fuse setter mounted near the loading tray, and a perfected sighting system for

direct fire that by means of differentials in the lateral and vertical sighting mechanisms insures the continuous following of the target by the gun pointer even when the deflections are being set. The gun is so designed that all operators work independently of each other and the effects of the efforts of one do not disturb the others. Each carriage has also a wind and parallax dial with a range (trajectory) chart which gives a means for obtaining the wind and parallax corrections and fuse range at the guns.

It is generally believed that the guns for antiaircraft fire must permit of being operated by either a direct or indirect system of fire control. But it is further believed that the direct system must be a simple emergency system and that the gun mount must possess simplicity and a minimum of instruments or devices for the computation or correction of data. The fundamental idea should be to keep the computation of data free, if possible, from the guns and therefore, away from shocks and disturbances. The computation of data must also be centralized.

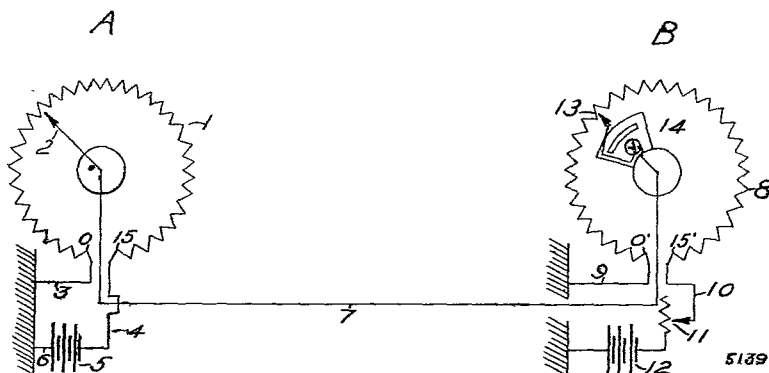

FIG. 2.

The 4.7-in. Gun with its 45 pound projectile must be equipped with some sort of loading device such as the pneumatic device with which it is equipped, but the value of such a device, on a 3-in. Gun, with only a 15 pound projectile, is doubted.

A fuse setting device that would automatically set the fuse as the projectile is loaded, or after the projectile is in the gun is a much needed invention. Such a device would reduce the dead time of loading to a minimum. The present fuse setter mounted near the loading tray, although an improvement, is believed not to satisfy the need.

The Morse Instrument Company has submitted the outline of three fuse setters which appear to have desirable features and which might satisfy this need. They are called the Automatic Electric Fuse Setter, the Automatic Mechanical Fuse Setter and the Naval Automatic Fuse Setter.

The Naval Automatic Fuse Setter is very simple in design, being an application of a form of a potentiometer as shown in Figure 2.

"A" is at the source of data, "B" is at the guns. The resistances at 1 and 8 are graduated in fuse settings. It is readily seen that when the reading 2 is the same as 13 that the voltmeter 14 will read zero. And therefore by keeping the voltmeter 14 reading zero we will have

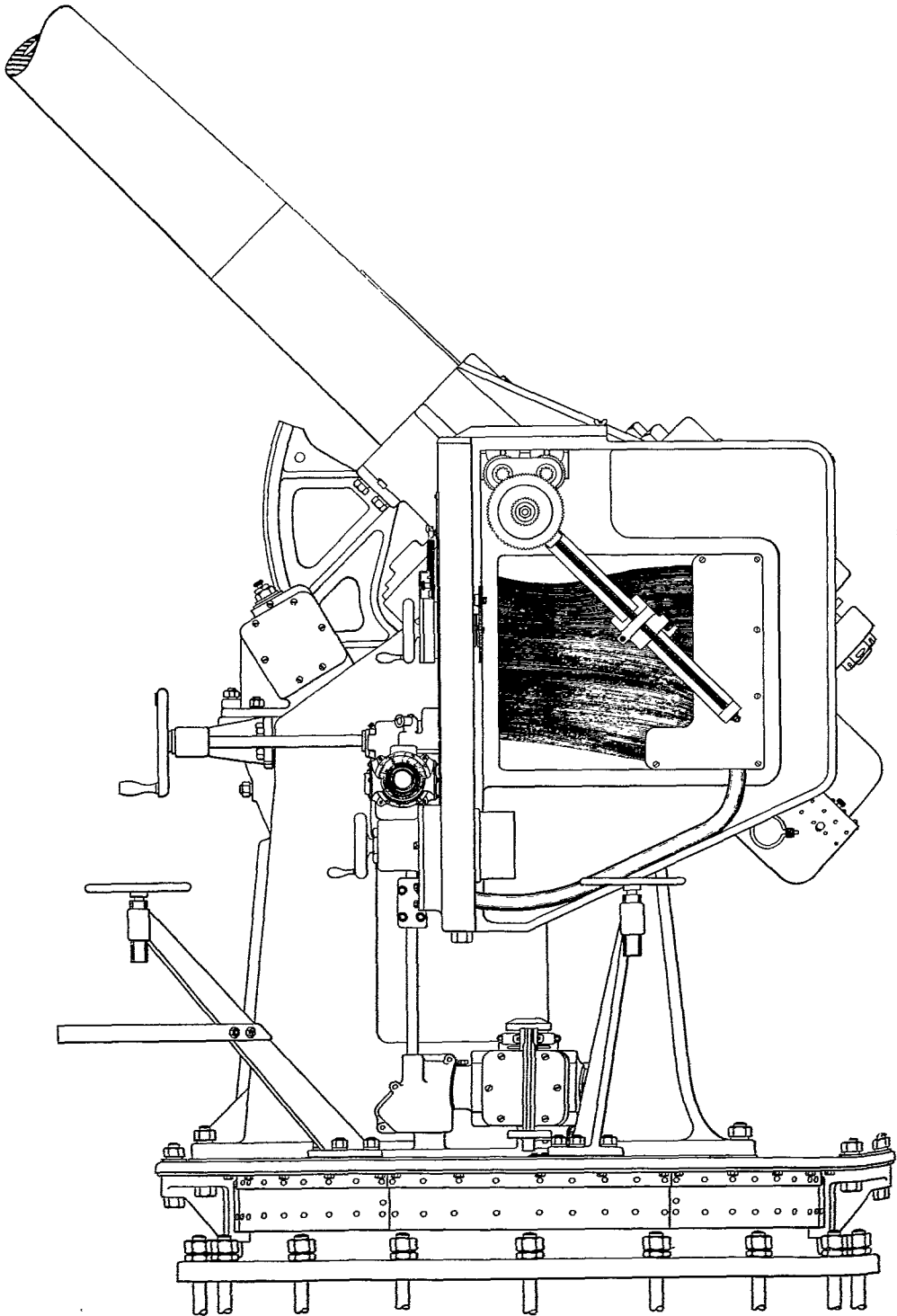

FIG. 3.

the same fuse setting at the guns as at the source of data. This device is so connected that when we make the setting at 13 we operate the worm of a bracket fuse setter and keep it at the fuse settings corresponding to the setting of 13.

The Automatic Mechanical Fuse Setter consists of a simple cam and corrective devices to take care of the errors that result from the simple cam's operation. This cam drives by means of a chain the worm of the ordinary bracket fuse setter. This device automatically keeps the cam moving as a direct function of the future fuse range which is determined as a function of the altitude and the angle of elevation. The movement of the cam necessary as a function of the altitude is obtained by setting the altitude, the movement necessary as a function of the angle of elevation is taken care of automatically by the gun. All three of these fuse setters have an additional desirable feature in that they, by means of an additional indicator on the device which records the fuse setting, give the fuse setter lead enough so as to take care of the change in fuse setting during the time necessary to cut the fuse, load and fire the gun.

The Automatic Electric Fuse Setter is best described by the inventor as follows: (See Fig. 3.)

"An arm extending diagonally down across a mechanism is rigidly attached to the trunnion of the gun, (or in some cases to the gun elevating gearing), so that the arm takes a position corresponding to the angle of elevation of the gun. Back of the arm is a solid integral mass, built up of metallic strips laid on edge. There are a large number of these strips,—one for each separate altitude setting,—and each strip has a different curvature corresponding to the variation in fuse setting for various angles of elevation at each altitude. The terminals of the strips are brought out into a cable which extends to the altitude controller. In operation at a particular altitude the particular strip for that altitude is not itself used, but the altitude controller functions to make all the strips on one side of that strip positive and all the strips on the other side negative. The boundary between the positive and negative electrical regions has thus a certain definite mechanical shape or curvature. A contact point, carried by a slide on the arm, automatically follows the boundary between the positive and negative regions as the arm swings to different angles of elevation.

"The slide carrying the contact point is moved along the arm by a longitudinal screw, which is driven thru gearing by a pair of small electric motors. These motors rotate in one direction or other according as the contact point touches a positive or negative region of the control block. The motors are thus controlled according to the curvature of the controlling strips. The motors also operate a parallel train of gears which extends to the fuse setter, so that the fuse settings are determined by the curvature of the controlling strips."

MONOSTATIC HEIGHT FINDERS

Long-base or bistatic altimeters or height finders have been used exclusively in our service for Antiaircraft Artillery.

They possess the following advantages.

(1) The maximum height which can be read with accuracy depends upon the length of base line, so if we increase the difference between stations, within limits, we can obtain accurate altitude readings to any desired height.

(2) These instruments are generally of simple construction, easy to operate and keep in adjustment, and are practically fool proof.

These long base or bistatic altimeters however possess the following disadvantages:

(1) It requires time and specialists to survey the base and orient the instruments.

(2) The maintenance of communications between the two stations at the ends of the base line is difficult.

(3) The personnel required is double that required for the single station instrument.

(4) Difficulty is always encountered in getting both stations on the same target, especially when there is more than one plane in the air. Bad visibility, assisted by the clouds and the sun, adds to this difficulty.

(5) The Battery Commander can not exercise direct control over both stations and therefore can not exercise proper supervision over them.

It has generally been admitted for a long while, that the disadvantages of the bistatic altimeter outweigh its advantages, and that the bistatic altimeter is impractical for use except for calibration purposes and in defenses of a more or less permanent nature. The British Government profited early by the lessons taught and adopted the Barr and Stroud Coincidence Height and Range Finder as standard equipment for A.A. units.

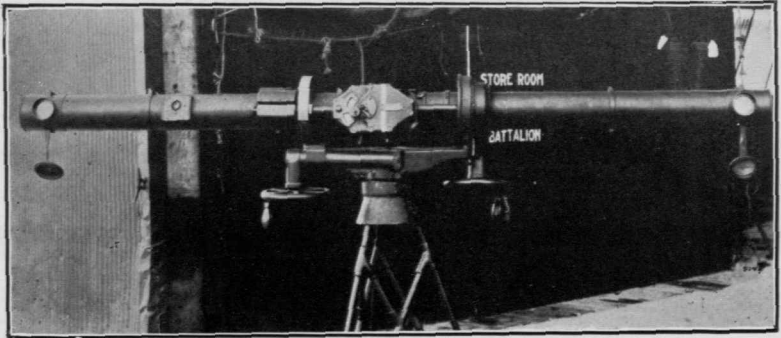

FIG. 4. THE BARR AND STROUD HEIGHT AND RANGE FINDER

We have been slow to make any changes but it is believed that the time has arrived for the adoption of single station instrument for height finding. The results obtained in tests held, but not completed, by the Coast Artillery Board at Fort Monroe, Virginia, seem to point to a favorable recommendation for immediate adoption of one of the various types tested. A brief description of some of the types tested follows:

THE BARR AND STROUD HEIGHT AND RANGE FINDER NO. 2 M K 11, TYPE U. B. 2

The Height and Range Finder as pictured in Figures 4 and 5 works on the coincidence principle—the field of view being of the inverted strip type and its operation similar to that of an ordinary Barr and Stroud Coincidence Range Finder with which every one is familiar. It differs however from the ordinary Range Finder in being provided with special gearings and being so mounted as to obtain from the combined motions of the range mechanism and the angular elevation of the instrument, a scale moving in accordance with the height of the object under observation. The height scale gear is in principle a mechanical device providing the solution of a simple trigonometric formula.

In Figure 6 if T represents the target, OT the range R , TD the height H , and TOD the angle α of elevation then $R \sin \alpha = H$, and $\log R + \log \sin \alpha = \log H$.

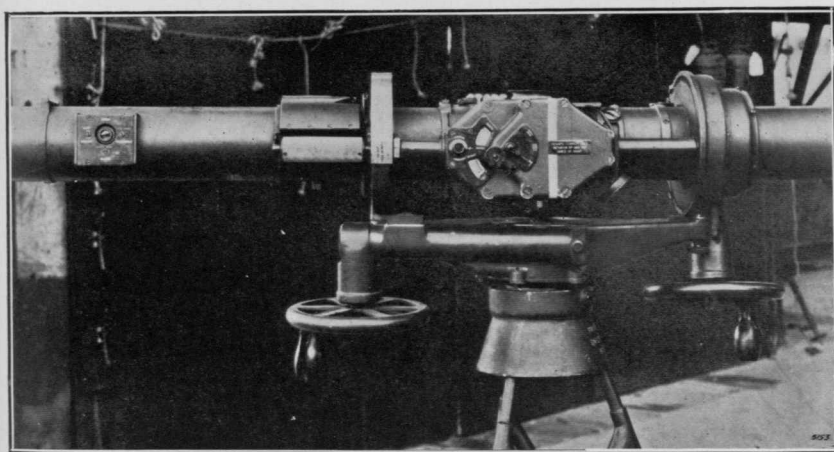

FIG. 5. CLOSE VIEW, BARR AND STROUD HEIGHT AND RANGE FINDER

If then we have a differential gear the upper member of which is rotated in accordance with a logarithmic sine scale of angle of elevation, and the lower member rotated in accordance with a logarithmic scale of ranges, the jockey wheel will revolve around the axis of the differential with a motion corresponding to a logarithmic scale of heights.

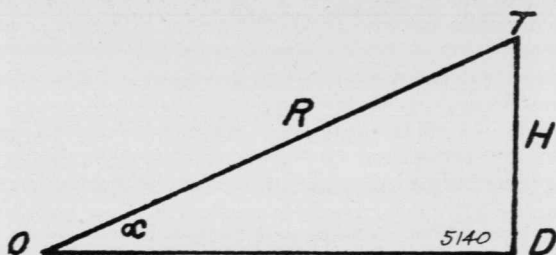

FIG. 6

In the actual instruments the conversion of the reciprocal range scale motion of the range finder deflecting prism gear into logarithmic range scale motion, and of the angular motion of the range finder in elevation into motion corresponding to a logarithmic scale of sines, is done in each case by means of specially designed toothed spiral gears.

Three persons are necessary to operate the instrument: Operator No. 1 who looks into the eyepiece at the center of the instrument and operates the working head and the elevating hand-wheel, Operator No. 2 who stands beside Operator No. 1, looks into the finder eyepiece and operates the azimuth training hand-wheel, Operator No. 3 who is on the opposite side of the instrument facing Operator No. 1, reads the altitude, and when desired can also read the range and angle of elevation.

The general characteristics of this instrument are given below.

Base Length	2 Meters
Magnification	15 to 25 diameters
Angular Field	1°36' Circular
Angular Height of Strip Field	0°5'
Range Scale Graduations (Range Finder)	From 2,000 to 25,000 yards
Range Scale Graduations (External Scale)	From 2,000 to 12,500 yards
Height Scale Graduations	From 1,000 to 30,000 feet
Finder Magnification	6 Diameters
Angular Field	About 6° Circular

This instrument can be easily moved about by the detail which is assigned to it.

TWO METER GOERZ STEREOSCOPIC RANGE FINDER FOR A.A. ARTILLERY

In stereoscopic range finding the apparent distance of pattern marks, visible in the field of view, from the target the range to which is to be found, is changed by rotating a range knob. As compared with fixed targets, the pattern marks then seem to recede or approach. An adjustment is then made so that the target seems to be exactly the same distance as the marks and the range can be read from the range scale provided.

The altitude is found from the Height Finding Attachment shown in Fig. 8 which is on the right end of the range finder. It consists of a lined window firmly attached to the range finder and a pendulum. The fixed window has two series of oblique lines numbered in hectometers, a black group indicating the height of the target and a red the map or horizontal ranges. The pendulum also, has two corresponding range scales, colored respectively black and red. The range found is referred to the pendulum of the height adjustment scale. The height of the target is read on the left side of the pendulum (black) and the map range on the right side (red). The lowest vertical mark of the pendulum registers angles of sight against an appropriate scale. This height finding attachment solves automatically a right triangle, for either of its legs, knowing the hypotenuse the range and one angle, (the angle of elevation.)

To operate this instrument three operators are needed, Operator No. 1 who observes for both direction and elevation, Operator No. 2 who reads the range and transmits it to—Operator No. 3 who reads the Height Finding Attachment.

General characteristics of this instrument are given below:

Base	2 Meters
Distance Measurable	1200-20,000 Meters

Optical Data

Range Finder: Magnification	20 times
Field of View	28 Meters at 1,000 Meters
Finder Telescopes: Magnification	4 times
Field of View	96 Meters at 1,000 Meters

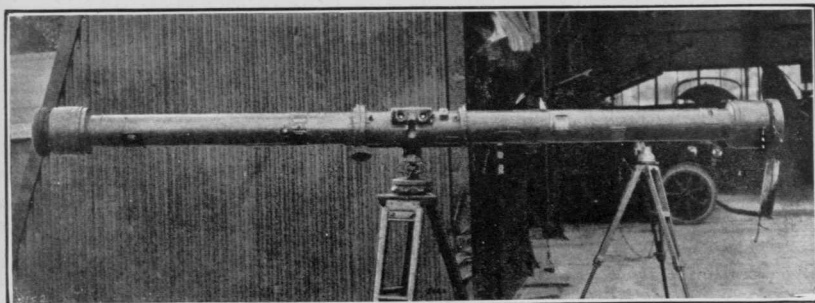

FIG. 7. GOERZ RANGE FINDER, 2 METER STEREOSCOPIC

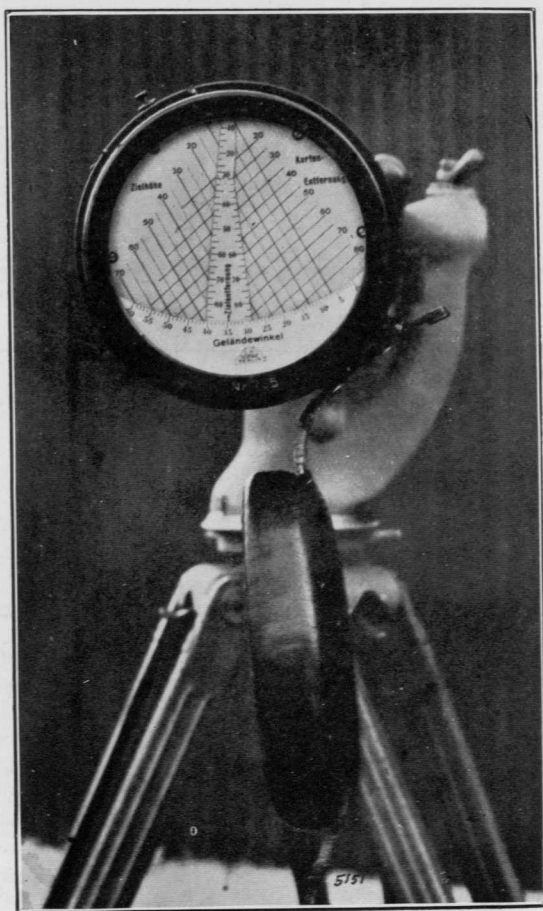

FIG. 8.

GOERZ 2 METER COINCIDENCE RANGE FINDER FOR A.A. ARTILLERY

This instrument is of the well known inverted image type of coincidence range finders, the field of view of the eyepiece being divided by a thin line into a larger lower portion and a smaller upper portion. The image which appears in the lower portion being upright, the upper image being inverted. By rotating a height adjustment screw both images are brought to the separating line. Then the lower image is shifted laterally by means of a range or measuring screw, until similar points or corners of the images are exactly above one another. The range is then read on the range scale.

The height finding attachment of this instrument is the same as shown in Fig. 8 and described above. The characteristics of this instrument are practically the same as given above for the 2 Meter Stereoscopic. Similar instruments have been designed and offered by Carl Zeiss, Jena. Goerz is also offering a 4 Meter Inverted Image Folding

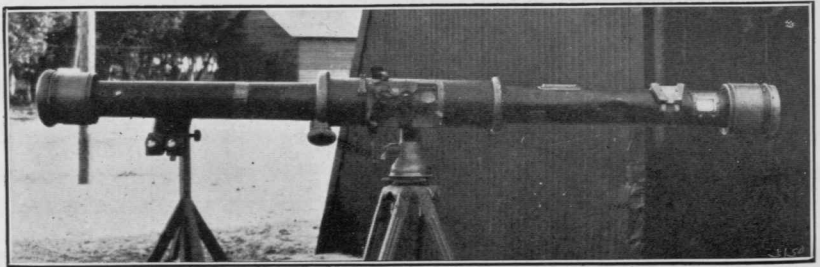

FIG. 9. GOERZ RANGE FINDER, 2 METER COINCIDENCE

Type of Range Finder with a distance measurable from 2,000 to 50,000 meters and a 4 meter Stereoscopic folding type with the same range. Both 4 meter instruments have greater fields of view than the corresponding 2 meter instruments and both instruments are equipped with a height finding device.

HEIGHT FINDING ATTACHMENT

The Height Finding Attachment scale is on one of the supports of the frame of the range finder. It consists of a quadrant A, Fig. 10, firmly fixed to the support. Along each edge there are linear graduations. The graph consists of two groups of lines numbered in hectameters, one indicating the height of the target and a second the horizontal range. An alidade scale B Fig. 10, is connected with the range finder by means of a rod and link so that it partakes of the vertical movement of the range finder and sets off automatically the angle of elevation. The Alidade is graduated in ranges to the target (actual distances, instrument to target). The distances measured with the range finder are referred to this scale and we can read, under these distances on the alidade the heights of the target or map range corresponding, as found on the graph described above.

These instruments described above, including those manufactured by Zeiss, are believed to be well adapted for Antiaircraft work. It is believed however that instruments of the stereoscopic type, although possessing a marked advantage in that they can be used to determine

the results of frings, i.e., the position of the bursts with reference to the target, are not practical in that the average man can not use them, if he does not possess stereoscopic vision. Although only exhaustive tests could determine the facts as to the actual percentage of persons possessing stereoscopic vision, it is not believed to be great. The two

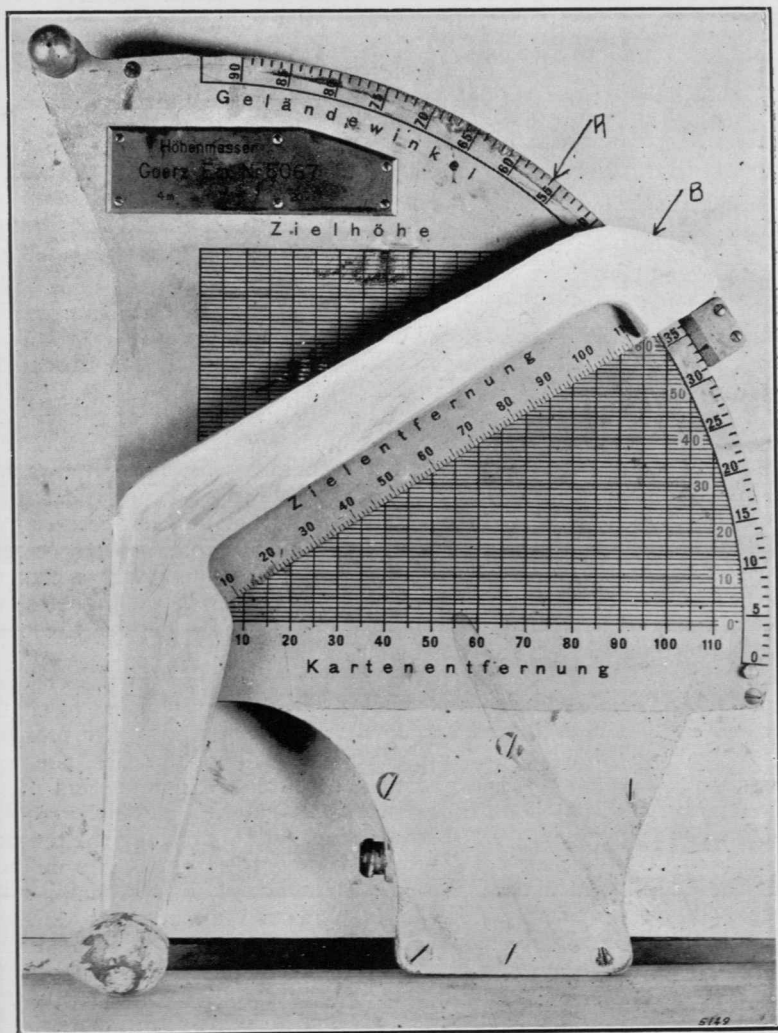

FIG. 10.

meter instruments in comparison with the U. S. Model 1920 altimeters (two stations) gave satisfactory results. The Barr and Stroud has advantages over the others in that the altitudes can be read directly. The two observers plan incorporated in that instrument, one for azimuth, and one for coincidence and elevation is believed to be good, for use against fast moving targets. The increased range of the 4 meter in-

struments is a very desirable feature but with the 2600 f/s Guns which are in the process of development, the two meter instruments are believed to satisfy the needs. The maximum range of the 3-in. A.A. Guns Model 1920 is 17,800 yards, of the 4.7-in. A.A. Model 1920 is 20,250 yards, of the Barr and Stroud 2 Meter coincidence instrument is 25,000 yards, and the Goerz 2 Meter Stereoscopic is 20,000 meters. These figures are taken from the manufacturer's pamphlets.

CLOCK WORK OR MECHANICAL FUSES

The ordinary powder train or combustion fuse was found in the early stages of anti-aircraft artillery development to be unsatisfactory and the need for a mechanical or clockwork fuse was ever present. The fact that a satisfactory clockwork fuse has been produced marks a great step forward.

The ordinary powder train fuse was a failure in anti-aircraft ammunition for the regularity of its functioning is directly dependent upon the regular burning of the powder train or composition. With the ordinary powder train fuse used in terrestrial fire this is impossible, for the rate of burning varies with the air pressure and in anti-aircraft or high angle firing the air pressure is a variable. Also it is known that the burning rate of a powder train fuse fired from a gun differs from the burning rate of the same fuse burned at rest. The higher the velocity of the shell, the quicker the composition burns; inversely, the rate of burning is slower with lower velocity and also with lower barometric pressure, as is the case when attacking targets at great altitudes. Experiments have shown that the mean rate of burning is decreased appreciably the higher the target is in the air. The results of these same experiments indicate that this decrease in rate of burning is not the result of the lower oxygen content of the thinner air in the higher strata of the atmosphere, but is due solely to the diminished air pressure which reduces the intensity of the burning process.

The facts stated above led to developments to make the ordinary powder train fuse suitable for use at high altitudes. This led to change in design so that combustion should take place under higher pressure. With increasing pressure, the intensity of burning increases, the temperature of combustion goes up and the process of combustion of the time ring composition thus takes place under conditions which resemble those in the normal case. The simplest means of increasing the pressure was to throttle the gases from the burning composition at the moment when they escape into the open air, by making the gas-escape holes smaller. Various types and designs of powder train fuses to do away with the effect of the decreasing air pressures encountered in higher altitudes have been developed along the line outlined above but the heights, at which they function regularly, are limited and it must be borne in mind that the heights from which aircraft can effectively do their assigned work have increased and are increasing rapidly. Furthermore, the high rate of travel of aircraft necessitates a gun with a high muzzle velocity in order to cut down the time of flight. This, as outlined above, affects the rate of burning and tends to make our problem of developing a suitable powder train fuse for anti-aircraft still more complex.

Combustion or powder train fuses have the great advantage of being possible of production in great volume in time of war. The clockwork fuse is difficult to make, and the clockwork must be regulated with

extreme precision, and most careful supervision is necessary throughout the manufacture of the fuse which necessarily limits the output in a limited space of time. Powder train fuses, which have been designed for antiaircraft fire, however, possess the disadvantage of not being able to be tested at rest, they must be tested by actual firings. The clock work fuse possesses the following advantages:

1. The action of a clock fuse is more regular than that of a combustion fuse because it can be so balanced or adjusted by trial that its regular action can be fairly well assured in flight.

2. The action of a clock work fuse is independent of daily atmospheric conditions such as density of the air, temperature and barometric pressure, which greatly affect the burning of a combustion fuse.

3. The timing mechanisms of mechanical fuses do not deteriorate rapidly in storage and they can be stored readily in places that are prohibitive for the storage of combustion fuses.

The technique of antiaircraft artillery is a precise science. Therefore there is demanded, for the solution of problems in antiaircraft gunnery, only accurate means and it is believed that only a clockwork or mechanical fuse can completely satisfy the demands that are made upon a fuse that is designed for antiaircraft artillery.

The following is a brief description of a fuse produced by Krupp. A recent observer has given out the information that this fuse has been improved and that it now gives results approaching perfection. The nature of the recent changes in this fuse are confidential and not given out by the German Government but the changes are believed to be few and the fundamental principle is illustrated in Figure 11 and description.

The frame of the clockwork mechanism consists of four brass plates, or laminations which are assembled to form a cylinder about one inch in height and three-fourths of an inch in radius. These plates are held together by three steel machine screws which also hold the mechanism to the base of the fuse casting, radial motion being further prevented by a steel dowell near the circumference of the plates which rest directly on each other, recesses being milled into the various plates to make space for the gear train, firing plunger, safety device, etc.

The gear train consists of a centrally pivoted shaft carrying the hand "A" geared through a train of gears to a governing device which regulates the speed of rotation of the hand "A." The entire device is driven by a stout watch spring mounted on the central shaft and wound by a key fitted into a recess of the top plate for this purpose. The governor device which occupies the space in the lowest plate, marked "M" consists of an escapement of the pendulum type, the pendulum being mounted with its axis of vibration at its middle point, also on the axis of rotation of the assembled fuse. The pendulum vibrates between the impulses of a star wheel, in which the gear train terminates, and the resistance of a small flat spring passing through the axis of the pendulum. This latter spring has an adjustment for length which controls the rate of vibration of the pendulum and by this means the speed of "A" about its axis.

The cap "N" is movable about its axis and has in its top surface a recess cut through which the hand "A" will pass when it revolves into alignment. The hand "A" is held in the starting position by a catch "B" which is released by inertia as the projectile moves forward on discharge. The hand on being released travels counter clockwise about its axis until it comes into alignment with the recess in the cap into

which is forced by a small coil spring under its pivot. This allows the firing lever "H" which is held in under a circular recess in the hand, to fly out releasing the striker "J" and exploding the detonator. The length of time elapsing between discharge and burst of the projectile is directly proportional to the angle, turned off with the cap "N," between the recess in the cap and the starting position of the hand "A." To prevent movement of this cap after discharge due to centrifugal force an inertia operated ring "P" is provided resting on five sharp steel points which rest on a fiber base. The shock of discharge drives the steel pins into the fiber base, preventing rotation of the cap.

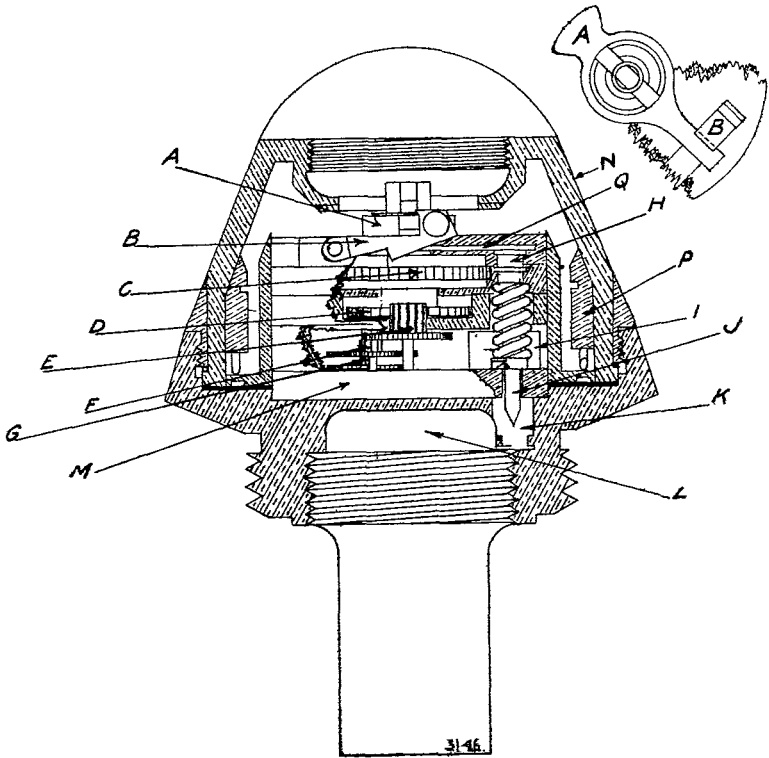

FIG. 11.

The striker also has a centrifugal safety device "I" which releases the striker from an intercepting lug, only when the fuse is spinning. This makes fuse safe if it does not operate in flight.

The fuse is capable of settings from 0 to 1 minute and can be reset to any setting or safe after having been set.

All joints are filled on assembly with a water and air tight liquid packing which allows the fuse to be packed in moist or damp climates without being attacked by rust.

A clockwork or mechanical fuse has also been developed which utilizes centrifugal force as the driving force, in place of the spiral clock spring described in the fuse above. It is maintained that a driving

mechanism with centrifugal plungers, giving a constant couple, combined with an escapement provided with a restraining pallet and a recoil pallet makes it possible to transmit to the balance more rapid oscillations than can be transmitted with a spiral spring. Hence greater precision is obtained but whether this greater precision is a necessity is yet to be determined.

DATA COMPUTING MACHINES

The last few months have marked the appearance of three additional possible solutions of the need for a centralized data computing machine or machines for antiaircraft artillery. The first plan submitted was that of an automatic plotting device and data computing machine or machines, the invention of Major W. P. Wilson, C. A. C. This plan contained many ingenious ideas and appeared to be basically sound in principle and worthy of development. It is similar in principle to "An automatic plotting scheme for antiaircraft artillery" gotten up by Major R. G. Goetzenberger, who is a consulting engineer with the Ordnance Department and who has done much to aid in the development of antiaircraft artillery in this country. The third plan offered is embodied in an "Automatic Battery Controller," the product of the Morse Instrument Company, Ithaca, New York, who have interested themselves in this problem and also in the development of Automatic Fuse Setters for use with this instrument.

At the conclusion of the War it was generally conceded that the first developments in antiaircraft artillery should have as their aim the cutting down of the dead time of maneuver and the time of flight of the projectile. This necessitated the development of a gun with high muzzle velocity and automatic devices for the computation and setting of data. The main problems encountered in the computation of data were the development of a means that would measure the velocity of the target and automatically multiply it by the proper time of flight of the projectile in a simple manner, yet without introducing complementary or secondary corrections, and the development of a means of selecting a proper time of flight so that the fuse length cut would cause the shell to burst at the future position of the target at the moment the target arrived at this position.

The use of automatic devices for the computation and setting of data is a necessity in antiaircraft fire, for the errors encountered appear to be a direct function of the time necessary to compute the data, lay and fire the gun, and that necessary for the projectile to reach the target. Automatic devices for the computation and setting of data reduce the dead time of maneuver to a minimum and thereby reduce the possible errors. Also automatic devices have the further advantage of doing away with practically all personnel errors. A complete automatic device must determine the future position of the target, and all the firing data necessary for the gun, including the fuse setting. This prediction and procurement of data and application of same must be rapid and continuous.

The importance of cutting down the time interval necessary for this computation of data, the transmitting of these data to the gun and the time necessary for the maneuver of the gun prior to firing, can be readily understood if one stops to consider the facts that planes today and in the future will fly at an average over 120 miles an hour, and that the time of flight which can be hardly reduced below 20 seconds, even

with improved equipment, coupled with a "dead time" of 8 to 10 seconds, will result in the gun being pointed a mile in front of the present position of the target. In a mile distance a plane can take many different positions and our chances of a hit at the best, with these conditions, are none too good. But above it has been maintained that the chances of a hit were indirectly proportional to these time intervals and if we then can decrease materially these time intervals we can increase our chances of success.

The question of adjusting antiaircraft fire is brought up daily and the ordinary artilleryman insists upon regulating the firing. Furthermore, various schemes are daily offered for barrage work and for improvised or emergency methods for fire control.

In ordinary land firings the fire is regulated by recording the distance between the target and the burst. This same idea cannot be carried out when firing against aerial targets, for if we have a very complex problem, where we make certain suppositions for a short time, we certainly will have a more complex problem, if we attempt to make additional suppositions during the longer time necessary to make a series of successive observations with intermediate adjustments. Certainly also the enemy, having been notified of the attack by the first series of bursts fired on the original data, will have plenty of time to vary his flight to avoid any succeeding series of bursts, if he sees fit. Also the calculations necessary to regulate properly antiaircraft fire, assuming that the airplane fails to vary its flight, would necessitate devices of equal importance to those necessary for the original computation of data, in order to make the proper allowances for the movement of the target. The results of barrage work against slow moving targets such as infantry, justify the use of the great number of guns and the ammunition necessary. But in view of the fact that aircraft with its great mobility can avoid easily any barrage within limits, it is useless to try a barrage unless you intend to cover the sky, with its unlimited dimensions. Furthermore, to stop effectively the progress of aircraft through any portion of space would require such a considerable amount of guns and ammunition that it would be prohibitive even in wartime when economy is forgotten. It must also be borne in mind that the efficiency of antiaircraft fire does not in any way depend upon the intensity of the fire, for a single shot placed close to the target spells ruin.

The French have maintained, and rightly so, that antiaircraft fire must be prepared and not regulated. It is of paramount importance that the data for antiaircraft fire be carefully and accurately prepared. Continual preparation must be effected for each shot. This preparation must be accurate to such a degree that it includes all errors possible, especially personnel errors. The time interval must be reduced to a minimum. Mechanical computing devices alone can satisfy these needs. Following are brief descriptions of devices that might satisfy the requirements. Major Wilson's plan is not described because accurate data on it are not available. This is to be regretted in view of the fact that it is believed to possess features well worthy of development.

THE R. A. CORRECTOR

The French during the World War developed an electro-mechanical device known as the Brocq A.A. Corrector and a purely mechanical device known as the R. A. Corrector for the computation of data. Actual

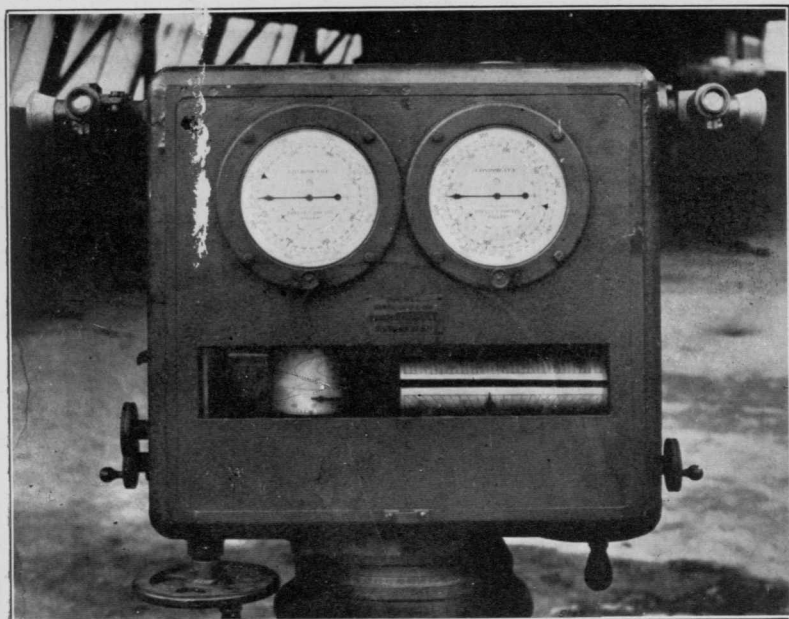

FIG. 12.

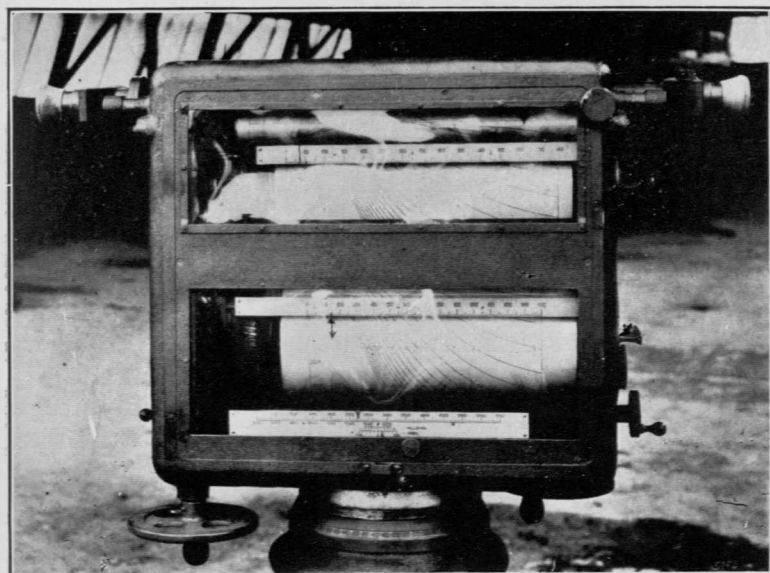

FIG. 13.

tests have proven that the Brocq A.A. Corrector is too frail for field use. The R. A. Corrector which is shown in Figures 12 and 13 is a purely mechanical device for the computation of data that can be used for either direct or indirect firing.

This instrument has been condemned by some for the reason that, as originally supplied, it was difficult to follow rapidly moving targets because the traversing and elevating gears were not properly designed, especially the traversing gears. But this is just a mechanical defect and it is hoped that it has been corrected in the instruments recently supplied.

This instrument with a height finder and a wind correction computer constitute the data computing devices necessary for a battery.

The mechanism of this apparatus, as shown in Figures 12 and 13, is contained in an aluminum case which is mounted upon a special steel tubular tripod. The observing part of the apparatus consists of two telescopes which move in elevation and azimuth, the movements being controlled by two handwheels, one handwheel moves both sights in elevation and the rate of turning necessary to keep on the target is the angular velocity in the vertical plane. The other handwheel moves both sights in azimuth and the rate of turning necessary to keep on the target is the angular velocity in a horizontal plane. This instrument obtains the true deflections by multiplying these angular velocities by a fictitious time of flight which has been calculated to correct for the erroneous assumption that angular travel during the time necessary for computing the data, laying and firing the gun, plus the time of flight of the projectile, is constant. These deflections are read on the two indicating dials shown in Figure 12 which are similar to the faces of ordinary speedometers. Each of these dials registers the speed of a system of gears inside the instrument which move proportionally to the speeds at which the handwheels are rotated, and to the position of rollers which move radially across friction discs as a function of the time of flight. By use of mechanical means, charts shown on Figure 13 are solved for the fuse range and the fictitious time of flight corresponding to the future position of the target.

For indirect fire, the elevation of the future position of the target is indicated on the middle straightline scale on Figure 13, the future azimuth on the circular mil scale underneath the case, and the fuse range to the future position of the target on the lower large cylinder inside the case.

AUTOMATIC PLOTTING SCHEME FOR ANTI-AIRCRAFT ARTILLERY OF MAJOR R. G. GOETZENBERGER

Major Goetzenberger's description of this scheme is quoted as follows:

"The mechanisms of this scheme of control are those involved within the commercial recording electrical devices of which the Leeds and Northrup potentiometer pyrometers are examples. Assume that through using a self-contained base range finder the target can be followed precisely in azimuth and elevation and that the sight range or altitude is continuously measured. These data can be transmitted to the computer through employment of a potentiometer circuit. See Figure 1-4.

"Since time of flight, t , is a function of angle of sight and sight range or altitude, it can be continuously registered in the following manner:

$$f_1(t) = f_2(s) + f_3(H)$$

The angle of sight transmission gives the function S . Fix a cam so that as it

turns through S, the follower is shifted up and down in a slot by a distance $f_2(S)$. Place a writing pen on a rod and adjust it at a distance $f_3(H)$ along the follower. The total movement of the pen, which can be made to record on the traveling sheet or plotting board element, gives the value of the time of flight on a scale $f_1(t)$.

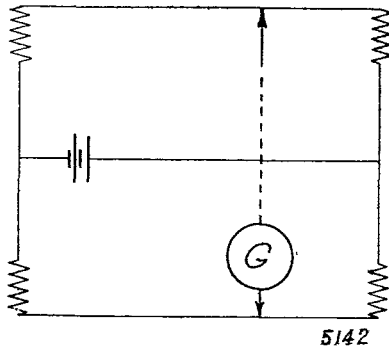

FIG. 14.

“The plotting board may take the following shape. Around two drums, one acting as the supply carrier and the other, the winding element driven from a clock work mechanism or constant speed d. c. motor, the paper is stretched. Intervals T (in seconds time of day) should be noted along the edge of the paper. The width of this paper might conveniently be 15 inches, which, upon assuming a 75 sec. maximum fuse, would mean a scale 1/5th inch to the second. If 1.5th sec. were the fuse accuracy, then the smallest scale reading would be .04 inches

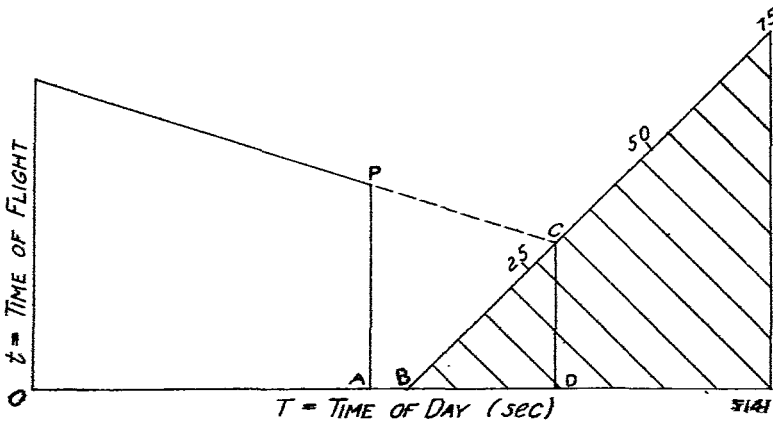

FIG. 15.

which is easily observed. As the paper travels from one cylinder to the other in function of T, the pen operated from the cam follower would draw or indicate by points a second's interval on the ordinate, the time of flight t corresponding to the present position of the target. Figure 15 shows the principle of the instrument.

- T—Time of day (seconds).
- P—Represents the present position of the target.
- PA—The time of flight to the present position.
- OA—The present time of day.

"Let the 45 degree triangle shown shaded be carried along with P, the corner B being a constant quantity (dead time) AB ahead of A. Let the curve of t be extrapolated (as shown dotted) to meet the edge of the triangle in C. Then CD represents the time of flight to the most probable future position of the target.

"It is believed that the future time of flight CD can be read by eye without continuation of the curve from P to C. The scale of time would be marked along the hypotenuse of the triangle, giving thereby an increased scale over the ordinate.

"In the case of a mechanical fuse, this time reading would be the fuse setting. But for the powder train one, it is necessary to convert, for example, in this manner, as a function of altitude and this future time of flight. The mechanism for this conversion might be simply a dial with curves of constant fuse range along which moves radially a slider in function of H, t being the polar angle to which the dial is turned.

"The possible advantages of this system as a predicting fuse indicator are—

- (1) There is no successive approximation to be carried out.
- (2) There are no secondary errors caused by changes of angular velocity during the time of flight due to motion of the target in the present vertical plane of sight, nor complementary errors which involve motion of the target at right angles to the present vertical plane of sight.
- (3) The future time of flight is read continuously without any setting of vertical deflection.

AZIMUTH

"The mechanism for the determination of future azimuth would be identical to that previously described with the exception that a straight scale rather than a triangular one would be used. This scale would be set to a distance, T-AD ahead of PA. The extrapolated point, corresponding to C, would give a direct reading to the scale of ordinates of future azimuth. Since there are 6400 mils in the complete circumference and it is, of course, desired that the plotting mechanism be a practical size (say 15 inches in width), it will be necessary to divide the circumference into say 16 parts. This would involve a separate transmission from the sighting element to the computer the number of the azimuth sector in which the target was flying. To establish the scale, we have 16/400 equals .04 inches, which seems a sufficiently great scale.

"The general procedure in obtaining the results are the same as finding t. The time of flight, t, must be known in order to establish the distance AD (dead time) which is assumed constant but adjustable for any particular gun crew plus the time of flight BD.

ANGLE OF SIGHT

"The angle of sight mechanism is similar in all regards to the azimuth device. On account of the 1500 mil movement of the telescope, it will be necessary to divide this amplitude into sectors. The operation is identical.

QUADRANT ELEVATION

"Since indirect firing only is involved, quadrant elevation and not angle of sight to the predicted future position of the target is required at the guns. This is readily obtainable in function of S and t or S and H. A cam might be employed to resolve this angle automatically.

PERSONNEL

"The personnel of the plotting computer might be limited to six persons, whose duties will be: three to balance the three potentiometer circuits, azimuth, angle of sight and range, and three to extrapolate the curves and announce their results.

ELECTRICAL AND MECHANICAL DETAILS

"The mechanisms involved are all accepted commercial articles in general use today. By virtue of the curve drawing devices, a permanent record of the firing can be kept. It is believed that a man of average intelligence can be trained to extrapolate without actually prolonging a curve to the precision of .04 inches, which, in time of flight, amounts to 1/5th second and in azimuth and angle of sight to 1 mil. The apparatus would be readily convertible into a manually operated unit, in case of failure of any part of the transmission system."

AUTOMATIC BATTERY CONTROLLER, MORSE INSTRUMENT COMPANY

This instrument is a centralized data computing device which it is claimed can compute all the data necessary for the operation of a battery,

including the secondary deflections. The only data necessary from outside sources are the altitude and the meteorological data. The handling and direction of the operation of this device are directly under a single officer who is charged with exercising the proper supervision over all the fire control operations necessary for the battery. The only other personnel required is two other men who take positions at telescopes used for tracking the target, one for azimuth, one for elevation. This instrument by means of electro-mechanical devices computes the super-elevation, drift, the time of flight, the effects of wind, the predicted fuse range, and the predicted horizontal and vertical deflections, and reduces and combines them to settings of fuse range, quadrant angle of elevation, and azimuth without any attention on the part of the operators except their continuous tracking of the target. It is also equipped with an altitude controlling lever which automatically regulates the altitude setting in case the airplane tries to vary its altitude to avoid the effects of the fire.

This instrument is controlled by an operator who takes position at "The Controlling officer's Telescope" which is a low powered telescope of unusually large field. In this telescope there is made visible not only the position of the airplane but also the point at which the guns are actually firing. This, of course, necessitates two pairs of cross-hairs, one central pair indicating the actual point at which the guns are firing, the other pair, which is movable in the field of view, indicating the present position of the target. The distance between the movable cross-hairs and the central pair of cross-hairs as seen in this telescope, indicates the lead of the point at which the guns are firing. The predicted lead as determined by an Automatic Predicting Device is also indicated in this telescope by means of two spots of light which cut the central pair of cross-hairs, at points corresponding to the vertical and horizontal components of the lead. The controlling officer therefore has only to put his movable cross-hairs on these spots of light to give the guns the actual predicted lead.

This telescope, and altitude and prediction control may also be used for picking up and identifying of targets, for taking care of curvilinear or non-constant flight and for training on actual airplanes and the checking of that training. It is readily seen that this telescope, having a large field of view, can pick up targets quickly and put the other two operators on by shifting their cross-hairs, which show in this control telescope, onto the target. The controlling officer by virtue of being able to control and vary the altitude and the amount of lead can, if his judgment is good, take care of curvilinear or non-constant flight. Also by halting at the instant of fire the cross-hairs indicating the future position of the target he can check the accuracy of the data by noting whether the plane is at this point or not at the end of the predicted time of flight. The determination of the amount of lead, horizontally and vertically, is made by two Automatic Predicting Mechanisms which are separate but identical in principle. The vertical and lateral components of the angular velocity of the target are multiplied in these mechanisms by the time of flight of the projectile. This multiplication is accomplished by an optical device shown in Figure 16.

The angular velocity is determined by a speedometer, driven by the pinion 1, which is geared to one of the control wheels of the pointer's sight. This causes the speedometer to be driven proportionately to the angular speed of the target. The angular speed of the target is indi-

cated, on this speedometer, by the position of a beam of light, which enters the speedometer drum 2 at the bottom, is reflected by an interior mirror, and passes out an inclined slot 3 in the side of the drum. This beam of light then passes through the vertical slot 4 to the lens 5. As a result we have a beam of light travelling up or down the lens 5, its positions indicating the angular speed of the target. The lens 5 converges this beam of light on the cross-hair 8 in the Controlling Officer's telescope. In order that the position of this spot of light shown at 10 shall involve the time of flight, the lens 5 is moved by the screw 11 to positions corresponding to the time of flight. This screw 11 is operated by gearing from a time of flight determining device called the Automatic Computing Block which is described below.

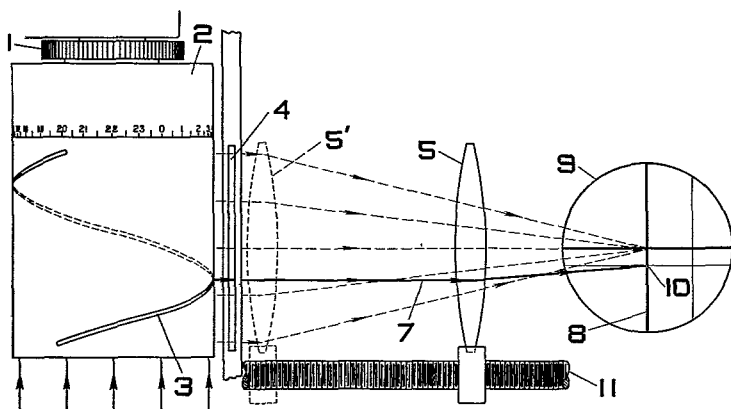

FIG. 16.

This Automatic Computing Block is a device for automatically computing the time of flight for all altitudes and angles of elevation. This block contains many control strips of various lengths, made of thin enough metal so that they can be readily bent to conform to any desired curve. The general principle of operation is that each strip corresponds to a different altitude; the curvature of the strip gives the value of the time of flight as the function of the altitude and the angle of elevation, and an arm which swings over this block in accordance with the angle carries a contact point which moves longitudinally along the arm and automatically follows any strip desired. The gearing which moves this contact point is connected to the screw 11 of the Automatic Predicting mechanism (Figure 16) and thus the motion of the time of flight lens is determined by the motion of the contact point, which motion is determined by the curvature of the Controlling Strip, hence by the values of the time of flight, as determined by the Automatic Computing Block.

The manner in which the contact point is made to follow automatically any desired strip is illustrated by referring to Figure 17.

This figure illustrates the general principle of operation of the Control or Computing Block. It shows the curved control strips connected to positive and negative batteries through the movable brushes of the altitude Controller, with a gap between the two brushes making a dead strip between the positive and negative regions of the Computing or

Control Block. The electric circuits are from the positive and negative batteries to the two respective groups of positive and negative control strips thence to the contact point to the control motors. The contact point is kept on the strip corresponding to the altitude as follows: the contact point is moved up and down the swinging arm by a screw, operated through gearing by a pair of D.C. Motors which are represented in the schematic drawing above by a single motor and a rack. Setting

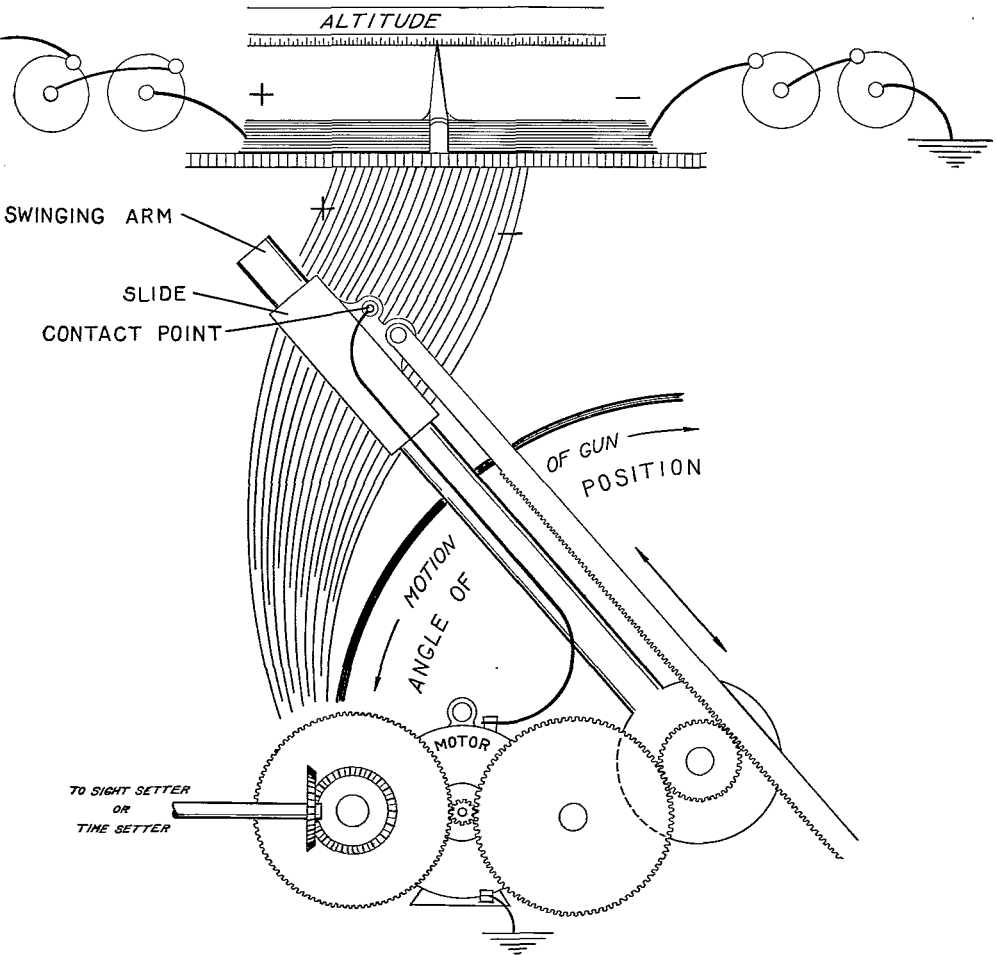

FIG. 17.

the altitude control for a certain altitude makes a strip, corresponding to this altitude dead. All the strips on one side of this particular strip are then positive, those on the other side are negative. When the contact point becomes displaced from the strip corresponding to the altitude set, it immediately encounters an E.M.F. which causes the motors to rotate in such a direction that it is forced back on the dead strip or dividing line between the positive and negative strips. Thus we see that the contact point is kept on the strip corresponding to the altitude

set and forced to take positions along a time of flight curve. With the Automatic Battery Controller, the transmission of data is accomplished through a follow the pointer system at the guns. This transmission system is of the Wheatstone Bridge type, voltages, not currents, being balanced against each other.

It is believed the use of the Automatic Battery Controller would be confined to permanent emplacements, due to its size and weight.

It is unofficially reported that the British Government has lately had under test two Automatic Computing Devices. The results of these tests, it is believed, were unfavorable. The first device tested was a Wilson-Dalby Computer, operated by electricity which at the present stage of development did not give satisfactory results. The other device tested was one gotten up by Vickers and appears to be an adaptation of the Brocq A.A. Corrector. It gave better results than the Wilson-Dalby but it is believed that the British A.A. Officers are of the same opinion as many in our service, and that the feeling towards electrical devices is an unfavorable one. The electrical devices tested and used to date are excellent in theory but fail to give proper results except under very favorable conditions.

DEVICES FOR THE LOCATION OF AIRCRAFT BY SOUND

The exact location by sound of the successive positions of a target in space is a problem whose solution is a necessity in order to insure accuracy in anti-aircraft fire at night. The solution of this problem is made difficult, by the lack of proper devices for sound detecting, and position plotting, by the effect of sound lag or acoustic aberration by the effect of wind, by parallax and by the effect of the atmospheric temperature gradient on the refraction of sound waves. The real and fundamental problem cannot be solved satisfactorily until there has been developed a sound detector that possesses the following qualifications:

1. *Acoustical accuracy.* Accuracy which is not of great importance for searchlights and machine guns, is of utmost importance for guns. It is believed that the mean error on a fixed source of sound should be below 0.5° .

2. *Small angular aperture of the acoustical field.* It is believed that the angular aperture of the field in order that a sound can be effectively followed should be narrow, 10° to 20° . This would aid greatly in preventing disturbances, and by cutting out interference would aid in differentiating between various types of sounds.

3. *Range of approximately 10 miles.* The range should be as great as possible but the range will be limited because of the inaccuracy of results at long ranges due to effects of wind, refraction, etc.

4. *Ease of manipulation.* The device must be easily manipulated or else the amount and accuracy of the results will suffer. The morale of the listener will be disturbed by unnatural position or difficult manipulation.

5. *Portability.* Except in Permanent Defenses portability must be seriously considered and it is believed that the device should be capable of being carried by hand, when dismounted.

6. *Convenient axes.* The axes, about which the device moves, should be such a system as to permit the following of the target overhead in a very easy manner.

7. *Simplicity.* The device should permit of being easily set up and taken down by the average soldier.

8. *Durability.* The device should be of sturdy construction, not easy to get out of adjustment, and should not wear out quickly.

9. *Rapidity of starting.* The device should be capable of functioning without delay.

In an effort to solve this problem the French and British Governments did, during the late War, a great deal of experiment and research; but at the end of the War there resulted only one device which it is believed, in its present state of development is adaptable for direction of gun fire, the Perrin Telesitemeter.

The underlying principle of practically all sound locating devices is that of detecting the difference of phase of the sound waves received by two receivers at a point midway between, there being no difference in phase when the plane of symmetry passing normal to the time joining the centers of the two receivers contains the source of sound. The detecting devices for the phase difference may be classed in two general divisions.

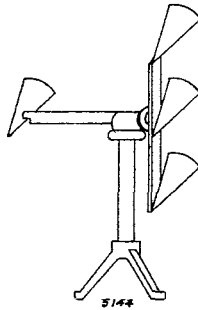

FIG. 18.

- (1) *Binauricular Detection*, that is by means of the human ear.
- (2) *Other Detectors*, which note the phase difference by observing the effect of these phase differences on vibrating membranes.

Binauricular detection of phase difference. The human ear is sensitive to phase difference in the sound wave as it enters the two ears. Instruments have been developed to accentuate this property of the human ear and they act so that the sensation of sound seems to be on one side of the head or the other as long as the sound source does not lie in the plane of symmetry of the receivers. The instruments first took the form of single trumpets, two of which were mounted several meters or less apart and connected through tubes of equal length to stethoscope ear pieces. In general, the sound thus reaching the ears will differ in phase, with the result that the source of sound appears to the listener to be to his right or his left. When however, the line joining the two receivers is perpendicular to the direction of the source of sound, this sound appears to the observer to come from a point directly ahead.

The British Government has developed and used with varying degrees of success three types of trumpets, respectively 18 inches in diameter, 27 inches in diameter and 36 inches in diameter. The 18 inch trumpets are generally mounted in groups of four, two being used for direction and two for elevation as shown in Figure 18.

These trumpets were used and designed primarily to direct searchlights at the front. When listening on a fixed source of sound they give a mean variation of about 0.5° . Their range is about the same as that of the human ear. For the 27 and 36 inch cones, the 4 cone instrument as illustrated in Figure 18 becomes two instruments of two trumpets each, one for direction and one for elevation. The range of the 36 inch cones is believed to be about 16,000 yards.

The French also tried single trumpets as receivers but later turned to hollow wooden cones, with five or six openings. At present they use a great number of small tin cones soldered together so that their large open ends lie in a given plane. See Figure 19.

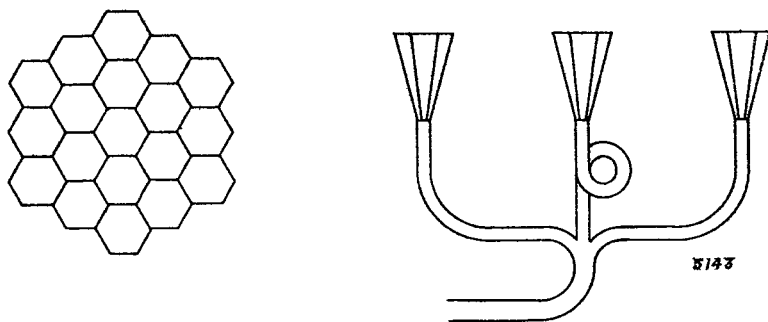

FIG. 19.

The cones are all joined to the same central tube by connecting tubes, of lengths so adjusted that the total length of air path from the opening to the central tube is the same for all cones, as shown schematically above. Thus, when the open face is placed perpendicularly to the direction of the source of sound, the disturbances reaching the central tube from all cones will be in the same phase. The group of cones therefore function as a large trumpet receiver. In other words one has a trumpet receiver of large opening and small vertical angle without excessive length. It is this multicone receiver that has been employed so successfully by the French and is used in the Perrin Telesitemeter. Professor Perrin, who is responsible for this work, has several methods for mounting these multi-cone groups but it is believed Figure 20 illustrates the most practical way and the method employed on the Perrin Telesitemeter.

Four multi-cone receivers are placed at the corners of a rigid square framework of 2 meters diagonal so that it may be rotated about either or both diagonals *b* and *c* as axes: The whole apparatus may be rotated about a vertical axis "*a*." Receivers R_1 and R_2 are joined by tubes of equal length to one pair of Stethoscope earpieces and receivers R'_1 and R'_2 to another pair, which requires two observers. It has also been proposed by Professor Perrin to have the receivers fixed in position and vary the length of the air path from one of the receivers to its stethoscope earpiece until the sounds from the two receivers reach the ears in the same phase. The adjustment is made by a slide trombone device, which is calibrated to read directly in angles.

Under this general heading of Binauricular Detection should probably be discussed sound mirrors which are generally of two forms. (1) Baillaud Paraboloid Type. (2) Spherical Types. These devices are

really Maximum Intensity Devices which employ the human ear as a detector but which embody in their use the principle of Binauricular Detection.

The Baillaud Paraboloid has a large parabolic reflector at whose focus is a collector or receiver connected with stethoscope earpieces. This parabolic reflector is moved about a vertical and horizontal axis, both passing through its center of gravity until the sound observed is a maximum. When the sound is a maximum the axis of the paraboloid coincides with the direction of the sound ray. The latest type of paraboloids employ four small receptors instead of one at the focus in order

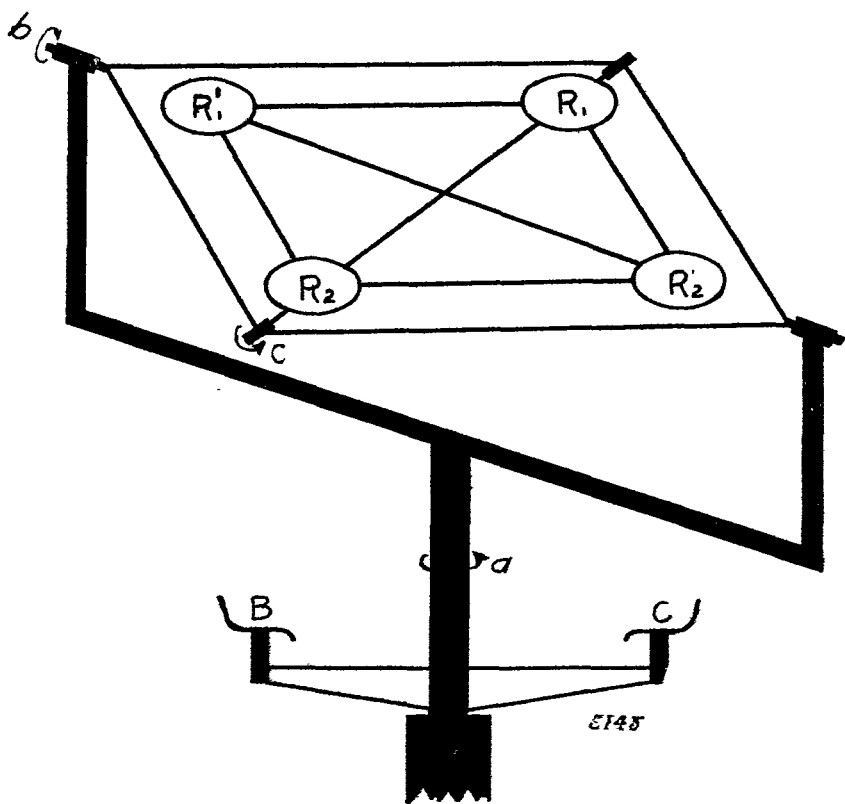

FIG. 20.

to facilitate adjustment. Paraboloids are more sensitive but less accurate than the Binauricular devices, described above. They also have given difficulty in operation due to varying atmospheric conditions which cause irregular variations in the intensity of the sound reaching the apparatus.

Captain W. T. Tucker, R. E. British Army, has done a great deal of research towards the development of Spherical Sound Reflectors and has conducted many experiments with both double and single types of Spherical Mirrors. These mirrors were installed on the English Coast near Dover, and the results obtained, it is believed, would indicate that they were not practical for adoption although they proved to be

highly efficient instruments for giving early warning, and getting bearings of the incoming enemy planes on a raid.

OTHER DETECTORS OF PHASE DIFFERENCE

Instruments, other than those described briefly above, for detecting this phase difference are, in general, based on methods of observing the effect of phase differences on vibrating membranes. These membranes in general, in order to be sufficiently sensitive to the sound waves, must be tuned to vibrate in the frequency of the sound received. If this is not done, for a sensitive membrane all outside noises will be taken up which will ruin the locating effect. The sounds of airplanes vary through wide limits and such a device requires that it be tuned to the sound of the particular airplane which is to be followed. This necessitates a great loss of time.

Captain Tucker of the British army has experimented with a device in which the recording instrument is a hot wire Microphone, said to be aperiodic and more sensitive than the human ear. It is believed that this instrument consisted of a fine platinum wire bent into loops and clamped between porcelain strips. The wire is of small diameter, $1/100$ to $1/800$ millimeter, and arranged so that it responds to the sound wave movements of the air surrounding it, by a change in resistance. The ordinary way of noting this change of resistance would be by a simple wheatstone bridge with the microphone in one arm of the circuit, but this is not so convenient as the use of a simple amplifying set. The microphone and heating battery are put in series with the primary of the transformer of the amplifying set, and the variations in resistance of the hot wire cause sufficient fluctuations of the current to be amplified in the ordinary way by a 3 stage amplifier. The amplified current could be observed by means of a telephone, a vibration galvanometer or by means of a crystal rectifier and a sensitive Sullivan galvanometer. Captain Tucker has used the microphones with double and single disc, and disc cones for magnification, and has gotten good results so far as indicating presence of aircraft overhead, but it is believed, that although great progress has been made, this device has not been proved practical for position location of aircraft.

Captain Bougier of the French Army has invented a device which translates a sound wave into motion, made visible by the movement of a spot of light. The results obtained therefore are made responsive to the eye rather than the ear. To accomplish these results two light collodion diaphragms are employed to which are jointed small mirrors mounted on axes at right angles to each other. Light from a convenient source falls on one mirror, is reflected to the other, and then is reflected to a suitable screen. If the membranes are executing a simple vibration, and are in phase the spot of light will traverse a straight line on the screen. If there is a difference in phase, the spot of light will trace an ellipse or circle. This device therefore gives a means of determining when two membranes are vibrating in phase. The two membranes receive the sound waves through tubes ending in trumpet shaped openings which are about two meters apart. The lengths of the tubes from the opening of the trumpet mouth to the membrane is the same in each case, so that whatever difference of phase exists at the trumpet mouths will still exist at the membranes themselves. When the two membranes are vibrating in phase, the sound is reaching the trumpet mouths in the same phase and the plane of the trumpet mouths is in the plane of

the wave front, which indicates the direction of the source of the sound. This device was impractical for adoption for antiaircraft work because of the trouble caused by parasitic noises.

In America it was thought better to devise a method of solving the problem of sound locating which would do away with sound lag and other corrections. This led to the development of a device to employ the heat radiated from airplanes against the background of the sky. It is believed however that this device did not go further than the experimental stages and was probably found impractical because of the delicacy of the apparatus, narrowness of the possible field and interference from other heat radiating sources.

SUMMARY

Devices based on binauricular phase difference detection, are considered the most practical. They generally possess the following marked advantages:

1. *Greater relative accuracy.*
2. *Narrow field and good selective power.* The field of this type of listening device may be made very narrow and the ear, which is the detector, can exercise intelligent selectivity.
3. *Rapidity of Starting.* No time is lost in tuning, etc. The device can function immediately.
4. *Simplicity.* The relative simplicity of trumpets in comparison with complicated electrical or optical devices is a decided advantage.
5. *Durability.* These devices are robust, easily taken care of and not easily put out of order.

Recent tests have proven decisively that the Perrin Telesitemeter is the superior of all other devices yet developed. It is probably too costly for the directing of searchlights and it gets results better than are needed for searchlight pointing. The problem for searchlights can best be handled by the English Cones or the Baillaud Paraboloid. The Perrin Telesitemeter is without doubt far in advance of any device thus far developed for the conducting of antiaircraft firing. Its only disadvantage is its cost, which is about 15,000 francs. The other devices (cones, paraboloids) have a mean error of about 0.6 degree against 0.13 degree for the Telesitemeter. It is believed that this device, which is the most accurate and most convenient in manipulation of those instruments yet developed, should be adopted by our service for test and that we should be repaid for the trouble and money spent, by the result obtained.

CONCLUSION

During the early stages of the World War the future of Antiaircraft Artillery was in doubt, as a conclusion from the results obtained. This was due, in entirety, to the fact that antiaircraft gunnery was not studied prior to the War. This meant that no matériel was developed, no instruments were available for the computation of data, and there were practically no data relative to the behavior of the elements of the trajectory at high angles of elevation. Study and research during the short period of hostilities resulted in remarkable progress, and the results obtained by antiaircraft artillery during the year 1918 indicate what further study and research might bring forth. The necessity for developments in antiaircraft matériel is great but the past has proved that the cost and trouble necessary to secure these developments are justified, and that we shall be more than repaid for our efforts.

Notes on Antiaircraft Machine Gun Fire

By Robert V. Morse, Consulting Engineer, Morse Instrument Co.



THE purpose of these notes is to briefly consider the problem of machine gun fire against airplane targets, in order to ascertain the line of development which will be most effective in extending the range and increasing the accuracy of such fire.

There are, so far as known, four possible methods of directing machine gun fire against rapidly moving aircraft: (1) by approximate sights, such as the trench antiaircraft sight, or the Peycru sight; (2) by tracer bullets showing the trajectories of the projectiles; (3) by a form of tracer showing, not the trajectories, but the curvature of the stream of fire, as from a hose; (4) by a form of tracer showing, not the trajectories, but the location of a single continuous bursting point, movable at will in space.

The high speed of the target makes the period of engagement very brief, at machine gun ranges, and necessitates a very simple form of fire control, consisting in general in making the fire visible, and pointing it on the target. As regards the use of sights, it suffices to say that various forms of antiaircraft machine gun sights aid considerably in directing the fire, but as there is no time to accurately determine data, such sights can only be approximate in their design. The gunner cannot ordinarily make these sights precise by rapid mental calculations; and in order to escape this burden, as well as to obtain greater accuracy, the tendency is to rely more and more on direct observation of fire in some form. It also has become vitally necessary to engage aircraft at longer ranges. At any but rather short ranges any form of approximate sight is practically useless.

The pointing of tracer fire, where the trajectory or path of each individual bullet can be seen, appears to be a very simple matter. Yet never are appearances more deceitful than when this type of fire is employed against a moving target. The mere fact that the projectile, as viewed by the gunner, apparently strikes the target at some point in its trajectory, is no indication that the target has in fact been struck, nor any real guide to the gunner in pointing his gun. The reason for this can be made apparent by a few simple diagrams.

Referring to Fig. 1, the solid line in the diagram represents a trajectory from a machine gun. The gun and a man standing by it are indicated at the lower right hand corner of the figure. A dotted straight

line extends from the eye of the man. The numbers on the trajectory indicate the time in half seconds interval.

From the viewpoint of the gunner, the appearance of an ordinary tracer projectile when fired at high angles is at first a line rising in the air. After a fraction of a second, however, the bullet appears to reach a fixed position in space, becomes a mere point, and then for a long period of time it neither rises or falls. If it is a night tracer, it hangs like a fixed star in the sky. Finally, after several seconds have passed, it begins to fall, and then falls rapidly. The reason will be obvious from Fig. 1. The straight line from the eye is so nearly tangent to the trajectory that the angular difference, from the viewpoint of the man, cannot be detected at any considerable range. This period, when the projectile apparently hangs fixed in space, covers the ranges during which effective fire is supposed to be conducted.

Now assume we are firing at an airplane traveling 130 miles per hour, (200 feet per second). Where should we lay the tracer point in order to hit the airplane? The best we can do is to guess at the amount of lead to allow; and observation of the fire will give little clue to the correctness of the estimate. For example, the tracer point may be laid as shown in Fig. 2, with the result as shown in half-second intervals across the picture. The tracer point of the projectile is shown by the dot in each square, and the airplane is shown approaching it. The airplane finally intercepts the tracer point at the 3 second position. But if the lead has been taken as in Fig. 3, the target would also have intercepted the tracer point, this time at the $2\frac{1}{2}$ second position; or if the gun had been pointed as in Fig. 4, the target would have met the tracer at the $1\frac{1}{2}$ second position. In each case the gun has apparently been well pointed,—or otherwise the tracer point would not have met the target at all; and yet the lead estimates have varied by 300 feet, and only one estimate could possibly be correct. As a matter of fact, none of the estimates may have been correct, and the target may not have been hit at all. For example, the true lead should perhaps have been 2 seconds, in which case the nearest approach of the bullet to the target was the 2 second position in Fig. 3,—an error of 100 feet. When the danger zone of a single bullet (not an explosive shell) is considered in relation to probable errors of the magnitude of 100 to 300 feet, it is evident that an enormous number of bullets,—many thousand—may be fired into the air with very little chance of bringing down an airplane. Under service conditions, and at the ranges visible with ordinary tracer bullets, the period of engagement seldom lasts more than 20 or 30 seconds, and only a few hundred shots can be fired.

It may be added that the travel of the airplane in Fig. 2, Fig. 3 and Fig. 4 has not been shown strictly to scale, as it was necessary to reduce the travel of the airplane in order to get six views on the paper. But this reduction of scale minimizes rather than exaggerates the difficul-

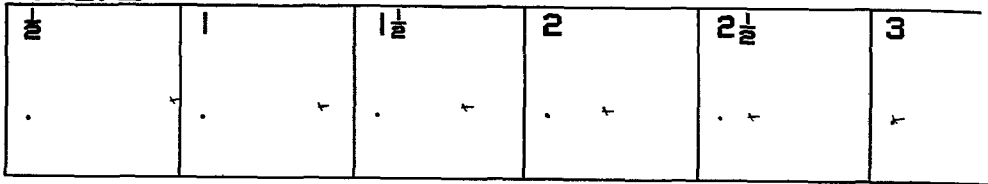
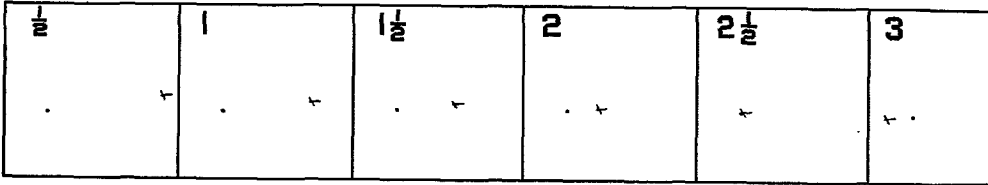
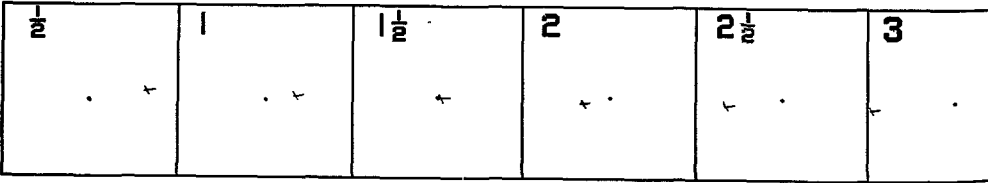
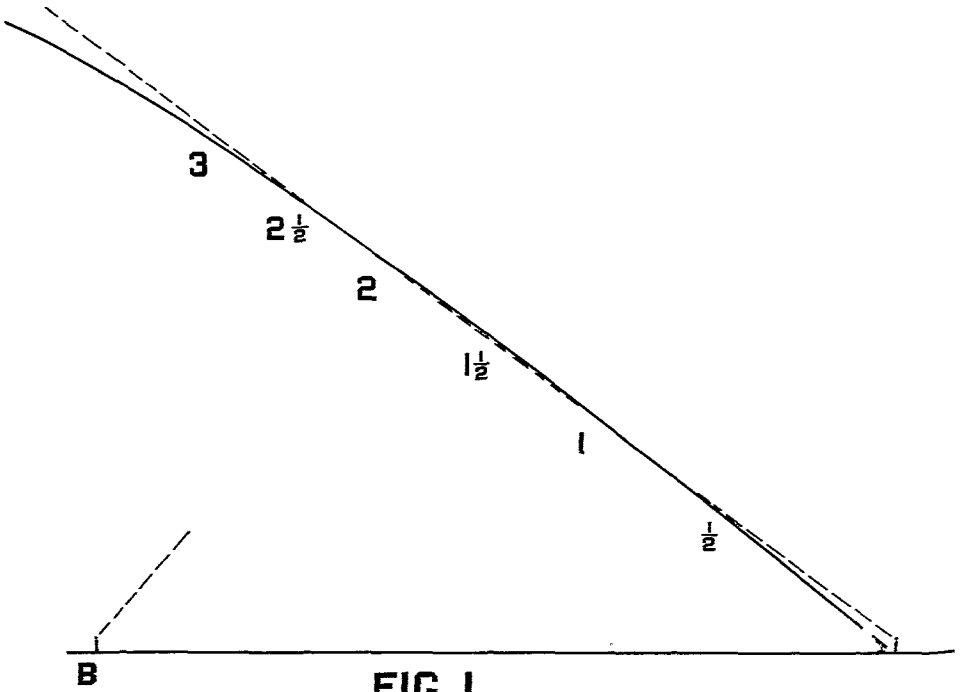
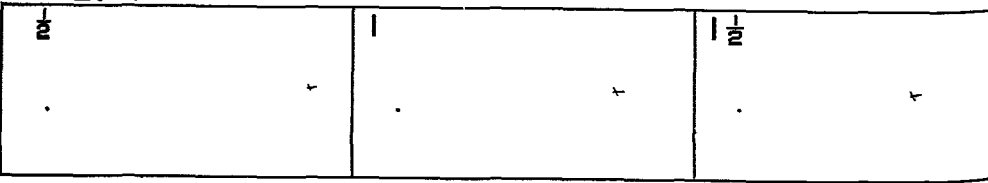
FIG. 2**FIG. 3****FIG. 4****FIG. 5****FIG. 1**

ties which such fire involves. If the paper had permitted drawings true to scale, Fig. 2 for example would have appeared as shown in Fig. 5,—on the basis that an airplane travels four times its length every half second,—so that the errors in the fire would be much greater than indicated in Fig. 2.

It might be argued that a tracer does not hang exactly fixed in the sky during the vital part of its trajectory, and that its slight apparent motion gives some clue to the gunner in intercepting the target at the correct range. To this it may be said that the tracer points in Fig. 2, Fig. 3, Fig. 4 and Fig. 5 have not all been placed exactly at the same elevation in all the squares, but have been raised or lowered in the various positions by the slight amount that would actually appear in space. If this variation has not been detected in looking at the diagrams, where the point might be located relative to the sides of the square, much less could it be detected when looking into the sky. As a matter of fact, the phenomenon of the fixed position of the projectile can be clearly seen by observing tracer fire, particularly at night. It will thus be apparent that any high development of ordinary tracer fire is precluded by fundamental optical limitations,—so far as rapidly moving targets are concerned.

Having outlined the difficulties of tracer fire on airplane targets, the question arises as to the best method of meeting the problem. It would appear that if a man were stationed at the point B in Fig. 1, with telephone communication to the man at the gun, he could tell whether it appeared to him that the fire was intercepting the target. Neither observer alone could determine positively, because neither could judge distances on his own line of vision; but if from both points of view the target appeared intercepted, the fire would undoubtedly be correct. In many cases, however, it would be very difficult for the observer at B to tell the gunner the amount or direction of his errors, since the man at B sees a line, not a definite point. It is true that if the line seen by B was on the target, and *at the same instant* the point seen by the gunner also intercepted the target, the fire would be correct. But if the target crossed the tracer point of the gunner at one instant, and apparently met the trajector as seen by B at another instant—say one second later—the fact that both men saw a hit would not mean that the fire was correct, since it is geometrically possible for the trajectory to appear to meet the target when in fact it lies between B and the target; and also the target can cross the gunner's tracer point at any other time than the correct one and not be hit. The use of a definite bursting point would of course overcome this difficulty, for then the two observers would register the same point or instant.

It has been proposed to use one pounder shells fitted with adjustable time fuses in large size machine guns of the pom-pom type,—such as are used in the Navy. It needs only the addition of an automatic fuse

setting mechanism which will rapidly set the fuses of the shells just before they enter the gun, to make a firing machine which will give a continuous bursting point in space. By a regulating handle on the automatic fuse setter the gunner can control the range of the bursting point as readily as the azimuth or elevation. He can thus move the bursting point at will in the three dimensions of space, and continuously pursue the airplane. Such systems of control are described in various patents. In general they give a more definite and accurate indication of the lead, and also increase visibility and permit engagements to open at longer ranges. In addition, the danger space of a shell having a time fuse is much greater than one that can only operate by impact, and of course much greater than a non-explosive projectile.

Looking into the future, the question might be raised as to whether some form of super-machine gun, firing 3" shells for example, with the range of the bursting point instantly controllable, might not be the ultimate solution of the anti-aircraft artillery problem. This brings up a fundamental limitation which applies to any form of fire control based on direct observation, including the continuous bursting point type as well as tracer types. Any such system is essentially a lagging system: the fire cannot possibly respond *instantly* to the desire of the gun pointer; there is always a lag corresponding to the time of flight, and no adjustment can be made until the fire is observed; whereas anti-aircraft artillery can operate on advance instantaneous predictions, making the first shot an aimed shot. The machine gun type of fire may be described as analogous to touching an object with a long and flexible pole; the pole may become so long as to be unwieldy, and hence there is a practical limit to such fire, probably about six or eight seconds fuse range. It is thus apparent that though the use of short time fuses and automatic setting can greatly extend the field of machine guns, machine guns can never take the place of anti-aircraft artillery at the longer ranges.

Anti-aircraft artillery is not generally employed at fuse ranges under four or five seconds, and so the two types of fire are ideal to supplement each other. At present the machine gun fire is too limited in range, and too uncertain in control, to completely fill up the gap to the ranges where anti-aircraft artillery becomes desirable. It is expected, however, that by developments such as are represented by recent inventions of the Morse Instrument Co. the gap can be completely bridged. In conclusion it may be stated that time fuses have been satisfactorily fitted to one pounder shells, suitable for use in machine guns of the pom-pom type.



EDITORIAL

Speaking of Moses—

IT is a short list, the roster of men who have achieved really enduring, world-wide fame. An occasional star leaves the beaten orbit of mediocrity or even preeminence, and starts a meteoric flight across the infinite spheres of time and fame, flashing a scintillating brilliance which promises to dazzle human eyes in the most distant ages. However, nearly all these stars have burned out and been lost, like cold meteorites, somewhere in their flight down the years. Once in a while, however, the light of human fame has not been burned out. There are a few names which are still widely known although their bearers have been cold, even for centuries. One of these names is more widely known today than in the dim historic dawn when he made his great decision and hewed to the line of his career. Moses, the brilliant protégé of Egyptian royalty, the lawgiver, and most significant to us, the military and political leader of a nation, is today respected by the peoples of three great religions, and his work and character are common knowledge in all the continents and islands of the earth.

Surely it may be interesting to speculate as to the reason for this perpetuation of a fame so widespread and enduring. Of course it is natural and easy to dismiss the matter with the obvious observation that the life story of Moses happens to be bound up with the essential cults of Jewry, Mohammedanism and Christianity, and it served the purposes of the priestly orders of these religions to keep alive the tradition of Moses, as a part of the common human groundwork of their divergent forms of religious propaganda. On closer analysis this conclusion lacks the satisfying finality of conviction, if for no other reason than that during the historical period common to the creedal development of these three religions, there were many other leaders of more or less outstanding character and achievements. Yet no other seems to be as widely known or as generally revered today as Moses. If then we care to look further for the cause of the fame of Moses, it seems natural to seek it in the personal character of the man rather than in the relation of his life to the doctrines of religion.

Frankly, the speculation in this direction is quite deliberately an instance of special pleading, for the purpose of bringing to the fore a line of thought which may have some interest to the Coast Artillery, and perhaps to the rest of the Army. Very probably the point of view to be set forth can be attacked successfully by a scholar versed in the

higher criticism. But unless such a scholar happens also to be a Coast Artilleryman, his objections will cheerfully be ruled out of court in the present discussion.

So then, to tie in Moses with present day Coast Artillery affairs. It seems that Moses was the adopted son of a King's daughter, and by reason of his favored situation in the most powerful and magnificent court in the world at that time, had the certain prospect of a lifetime of cultured ease, of association with all the best people, of participation in all the good sport and expensive revelry that royalty could command. All that the world had then to offer of literature, art and music were at his hand. If he were disposed to be a fancy dresser, he could be up to the minute with the finest products of the tailors and jewelers of the Nile valley. Should he choose the satisfactions of scholarship and philosophy, the high-brows of the ancient world would be honored to have his company. Should he desire to "go out among 'em," where was the festive and beautiful damsel to say him nay? Quite literally, he had both hands up to the elbows in the fleshpots of Egypt, with a ten to one shot that no change in administration would pry him loose throughout a long and happy life. Such, briefly stated, is the historical background which we must clearly visualize if we are to appraise correctly the significance of the career of Moses.

In short, he deliberately passed up every foreseeable chance of recognition, power, or renown, forsook his strategic position amidst the fleshpots of Egypt, espoused the cause of an insignificant and socially outré minority, and assumed the apparently thankless and certainly unremunerative task of leading a bonded people through years of desert wandering, in defiance of his foster-grandfather and boyhood's friend, the Pharaoh of Egypt. Surely, on the face of it, this was a poor bid for immortal fame.

Nevertheless, by any human standards, we now may conclude that Moses proved to be a successful man. Surely, the reason his fame endures lies in these facts—first, he was convinced that he was offered a worth-while job of leadership; second, in loyally devoting himself to this job he was willing to pass up all predictable chances for fame; and third, he had the willpower not to be sidetracked by the lure of the fleshpots of Egypt.

Now, in a small way, every army officer may choose to be a young edition of Moses, but only by paying Moses's own price in decision and renunciation, and without, indeed, any real prospect of any Mosaic reward in the recognition of future generations.

When we may read, as we have in the *Army and Navy Register* of March 31, 1923, that large numbers of our fellow citizens, worthy and sincere as they are, can depreciate and attack the work we are doing, in the aspersive terms employed by such persons as Harriet Connor Brown, we cannot fail to realize that we are devoted to a cause which will continue to be, as it has often been, unpopular, misunderstood, and maligned. As far as recognition, reward and approval are concerned, we are on the wrong side of the fence. To be sure, in the public hysteria which invariably marks the opening of a war, the soldier is accorded a transient respect which is conveniently forgotten almost as soon as the last echo of the guns has died away. And so it is that if we, like Moses, see a call to leadership which others do not see, we must, like Moses, obey the vision with renunciation.

Now Moses "went the whole route." He left the fleshpots behind

him, and unencumbered, played the game he had chosen. In something like this consistency lies our challenge and our only chance. In the earlier years of an officer's career, before he has initially covered the ground in the mastery of the immediate technical demands of his profession, his nose is necessarily much to the grindstone, lest he fail conspicuously and be eliminated. But there comes a time when he feels that he has acquired a safely solid reputation, when the grinding pressure of his subordinate apprenticeship is relaxed. Now is the time when he needs a Mosaic inspiration, because now he is confronted by the temptation of the fleshpots. For instance there appear to him certain assignments more desirable than others, in that they afford greater leisure, readier access to urban life and pleasures, less responsibility, less study and concentrated effort than do other assignments, some of which, nevertheless, afford the opportunity for professional development and for heightened mental alertness. He has but one life to live, and the Epicurean suggestion asserts itself that it is folly needlessly to forego the physical satisfactions which may sometimes be had for the asking, when the alternative is a lifelong grind of hard work in preparation for the wholly uncertain prospect of high command in war, with its equally uncertain reward in promotion and in fame.

In every walk of life, a considerable proportion of men are, and have always been, actuated, consciously or unconsciously, by an Epicurean and egoist philosophy. Unfortunately the army has its corresponding proportion of officers so actuated. To some of these the significance of the present argument will be incomprehensible or ridiculous. But many of the friends of the youthful Moses, with whom he had sat amidst the fleshpots of Egypt, must have thought him a fool to leave them. Yet who knows the name of one of these?

Generally unappreciated as is the fact, we in the Army are in a position to know that the conditions of modern war have become so complicated and tremendous that military leadership has literally become the task of a superman, if it is to be free from mistakes and failure. Consider then the need that at least a certain proportion shall forego the fleshpots, and with almost monastic zeal shall prepare themselves utterly for the great responsibility. Successful leadership of the larger units in our next war will not be the result of inherent genius, eleventh hour inspiration or timely hunches. Not all the higher commanders of either the German or French armies in the World War were faultless in their decisions, and yet the outstanding names in both armies are of men who, under a rigorous system to which we have no parallel, had devoted their whole lives to a most intensive preparation for the roles they were selected to play in the great struggle.

We have but one life to live. From one standpoint, every life is meaningless and futile, and as soon dissipated as its bodily tenement, except for the positive result of its impact on the constantly flowing stream of human activity. The world unquestionably needs the high voltage impact of an occasional Moses. The individual Coast Artillery problem is—for the possible chance of meeting the need of great leadership, is the necessarily unremitting program of personal development worth while?

From the standpoint of convincing our critical countrymen of the necessity and worthwhileness of their investment in our effort, it could be wished that every officer might be a zealot in his profession, a figure of outstanding personality, determination and mentality. This is too

much to hope for, yet surely there are many who can catch the vision. Any parable can be pushed to an absurdity. There was but one Moses, and the particular task of a Moses will never be called for again. But the sort of leadership which was typified in the life of Moses—self sacrificing, patient, wise and determined—will be in demand. And the prepared and courageous character of a Moses will be needed not only in one individual, but in many. The Army should stand ready to furnish not one Moses alone, but a whole Mosaic team. What if the call never comes? Is it not still better to wear out than to rust out? Again, is there anything in life more pitiful than the man thrust upon a great occasion, who is tried in the balance and found wanting? To him who can catch the vision there is opened an arduous road whose end cannot be seen, a road of unremitting labor, study and reflection, a road which leads ever and ever away from the peaceful valley and the beguiling fleshpots of Egypt.



A. A. in the Big Tent

Every once in a while the suspicion crops up that somebody has a wrong steer on this or that idea in connection with Coast Defense, the especial job of the Coast Artillery. Perhaps this is not surprising, and no doubt other branches of the service, as well as other human activities, are subject occasionally to a similar degree of misapprehension. Just now it has been discovered that there are apparently a few people who think that Antiaircraft Artillery is a Coast Artillery side show, and even admitting that it is a mighty interesting, not to say important, side show, yet it is still outside the big tent of Coast Artillery activity and responsibility. While it is surprising that such a misconception has ever found footing, yet as long as there may be anyone who hasn't fully considered the status of Antiaircraft Defense, it is worth while to emphasize the fact that Antiaircraft Defense is primarily an important and integral element of the *main job* of the Coast Artillery—namely, Coast Defense.

It is now generally recognized that the Navy, the Coast Artillery and the Air Service must share, with the fullest cooperation and the freest interchange of ideas, the task of Coast Defense. In so far as there may be any expectation of attack against our maritime frontiers in a future war, this attack may be predicted to come both over the water and through the air. It has been well recognized that the Coast Artillery and the Air Service share a mutual responsibility for opposing the attack of naval vessels so as to free our Navy from embarrassment as to its home bases, and permit our Navy to act offensively in distant waters. It should be equally recognized as a part of the same responsibility, functioning in an entirely comparable manner, that the Coast Artillery and the Air Service should supplement each other in repelling attacks against our coast line which may come through the air. There should be no need to elaborate here on the tactical division of function as between the Navy and these two branches of the Army, a division which has been evolved naturally through the differences in the technical weapons at the disposal of the three services.

What is important to emphasize is that inasmuch as Coast Defense represents the major element in our entire problem of National Defense,

whether it concerns the continental United States, or our over-seas possessions, the principal function of Antiaircraft Defense thereby becomes one of Coast Defense. The task of the Antiaircraft Service in the Coast Artillery presents its most difficult phase when working in Coast Defense, just as the execution of the mission of the Air Service has its most difficult element in the Air Service share of Coast Defense. If all the elements of Antiaircraft Defense, including Antiaircraft Artillery, Antiaircraft Machine Guns, Searchlights, Listening Service, and Barrage Balloons, can function effectively in connection with Coast Defense, they can assuredly so function in connection with purely land warfare operations. This significant viewpoint may be maintained without in any way minimizing the importance of Antiaircraft Defense in the local defense of cities and utilities, or the necessity of efficient Antiaircraft units with armies in the field.

Consequently, no one should look upon the assignment to the Coast Artillery Corps of Antiaircraft Defense as a mere accident of War Department policy, but should appreciate it in its true light as the natural and indeed only logical assignment of responsibility for this highly important service.

If all this be granted there will then be justified the conclusion that every Coast Artilleryman should avoid the attitude of being an uncompromising enthusiast for only one of the weapons or individual specialties of the Coast Artillery Corps. The time has passed when any Coast Artillery officer should feel warranted in regarding himself a Submarine Mine man, a Mortar man, a Fixed Gun man, a Tractor Artilleryman, a Railway Artilleryman or an Antiaircraft man. All of these seeming specialties are very directly related, and he, and he only, is justified in considering himself a competent Coast Artilleryman, who has so far covered the ground that he can fit in efficiently with any type of organization pertaining to the Coast Artillery.

While the distinguishing characteristic of Coast Artillery, its manipulation of tremendous fire power, symmetrically blended by its various weapons for the accomplishment of the most immediately necessary demands of National Defense, may not wholly be appreciated as yet by all other persons, nevertheless every Coast Artilleryman may well take pride in the mission, the weapons, and the methods which preeminently mark the Coast Artillery as **THE ARM OF POWER.**

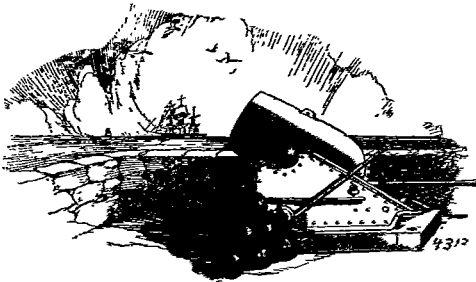

COAST ARTILLERY BOARD NOTES

"Communications relating to the development or improvement in methods or materiel for the Coast Artillery will be welcome from any member of the corps or of the service at large. These communications, with models or drawings of devices proposed may be *sent direct* to the Coast Artillery Board, Fort Monroe, Virginia, and will receive careful consideration."

JOURNAL OF U. S. ARTILLERY, JUNE, 1922.

Work of the Board for the Month of March, 1923

1. Colonel H. J. Hatch, C. A. C., has returned for duty as President of the Board. 1st Lieutenant G. W. Morris, Signal Corps, has been transferred. Major James B. Gillespie, Ordnance Department, has reported for duty with the Board, relieving Major W. B. Hardigg, Ordnance Department, transferred.

2. In accordance with instructions from the Chief of Coast Artillery, the Board is relieved from the initial preparation of Training Regulations, this work having been assigned to other agencies.

3. The Chief of Coast Artillery has further announced the policy that the Coast Artillery Board is to be regarded as an agency of the Office of the Chief of Coast Artillery in the performance of its technical functions. The Coast Artillery Board is the superior board for the consideration of Coast Artillery matters. All studies or tests of materials that are to be acted on by boards or other agencies within the Training Center are referred to the Coast Artillery Board and tests and studies are held under the supervision of the Board.

4. The following Training Regulations were received for comment during March, 1923:

a. Training Regulations 320-90 (Ordnance Department), 12-inch Mortar Carriages, Models of 1896 MIII, and 1912. Prepared by Ordnance Department, Project No. 90. Reviewed by the Board and comments submitted to the Chief of Coast Artillery.

b. Training Regulations 435-97. Headquarters Detachment and Combat Train, Separate Battalion, Antiaircraft Artillery, and 435-98, Separate Battalion, Antiaircraft Artillery, Projects Nos. 100 and 101. Prepared in the Coast Artillery Training Center. Studies in progress.

5. New Projects initiated during March, 1923.

a. Project No. 91. Issue of shotguns, traps and ammunition to antiaircraft units for training purposes.—Such issue was proposed because it was believed that shotgun practice at clay pigeon targets would assist in the development of efficient gunners. The Board was of the opinion that the advantages that might be derived from trap-shooting would not justify the expenditure involved. This opinion was concurred in by the Chief of Coast Artillery.

b. Project No. 92. Fire Control Installation and Equipment for R. R. Artillery.—This study is undertaken by the Board with a view to recommending standard fire control equipment for R. R. Artillery units.

c. Project No. 93. Wells Mechanical Predictor. This device was designed by Captain G. A. Wells, Ordnance Department, and was formerly before the

Board. It is reconsidered at this time with other predictors for the purpose of developing, if possible, a device more efficient and suitable than the prediction ruler and pantograph used at present.

d. Project No. 94. Manuscript of Firing Tables for 12-inch Mortars.—A tentative form of firing tables for 12-inch mortars submitted by the Ordnance Department involving a radical change in the old range tables, the new form being made to agree with the standard recently adopted for the Coast Artillery Corps.

e. Project No. 95. A Hyperbolograph (Sound Ranging Plotting Board) designed by 1st Lieutenant Chas. M. Myers, C. A. C., of Fort Eustis, and submitted direct. This device is designed to construct hyperbolas. It will be considered in connection with other devices designed for the same purpose, and capable of application in the Sound Ranging Problem.

f. Project No. 96. Army Flashlight, Model 1922 (Experimental). Designed for general use in the Army and particularly for illumination of cross hairs of observing instruments and the reading of maps with a minimum of light visible from overhead. The flashlight will be given a test at Fort Eustis and Fort Monroe.

g. Project No. 97. Range Correction Charts for 12-inch Mortars and Project No. 99, Range Corrections Charts for 8-inch R. R. mount, firing High Explosive Shell.—The preparation of these charts is in progress.

h. Project No. 98. Range-Range Relation Tables.—In this connection refer to paragraph 4 (d), Coast Artillery Board Notes appearing in the January, 1923, number of the COAST ARTILLERY JOURNAL and to paragraph 4 of Coast Artillery Board Notes in April, 1923, COAST ARTILLERY JOURNAL. These tables are to be constructed for use at batteries using projectiles of different weights, the range drum being graduated for the standard projectile.

i. Project No. 102. Brocq Corrector and R. A. Corrector for Antiaircraft Artillery.—The question of the relative merits of these devices, and which should be issued to Antiaircraft Artillery units has been referred to the Board and is under consideration.

6. Projects previously submitted on which work has been accomplished.

a. Project No. 46. Preparation of Fire Control Charts for 12-inch Long Range Battery, Fort Mills, completed. Charts approved and forwarded.

b. Project No. 76. Form for tabulating Range and Deflection Effects due to Rotation of the Earth forwarded and approved by the Chief of Coast Artillery. This form is to be embodied in firing tables issued hereafter.

c. Project No. 88. Issue of Gun Oil.—The Board considered the allowance of gun oil at present authorized in Tables of Basic Allowances, Note 31, Circular 169, War Department, 1921, and further, the supplying of oil automatically as part of the daily ration allowance when troops are in the field. The Board recommended as follows:

(1) That the issue of gun oil to troops in the field should be made automatically every seven days as part of the ration allowance.

(2) That the following allowances be prescribed for every six months in garrison, the regular garrison issue to be made on semi-annual requisitions as prescribed in Note 31, Circular 169, War Department, 1921, (Tables of Basic Allowances.)

Gun Oil—Pints

100 pistols	7½	(in 2-Oz. cans)
100 rifles	18	(in 2-Oz. cans)
8 automatic rifles	3	(in 2-Oz. cans)
2 A.A. Machine Guns, .30 Cal.	6	(in pint cans)
16 Machine Guns, .30 Cal.	48	(in pint cans)

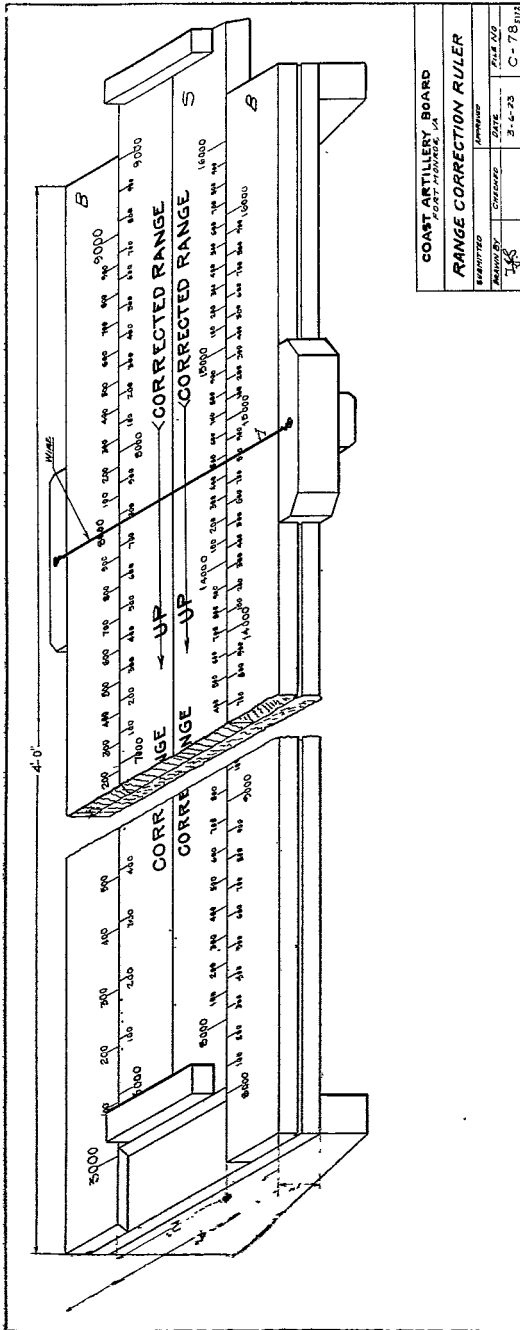

Fig. 1

That $1/6$ (one sixth) of the above allowances be issued automatically every seven days as part of the ration allowance to troops in the field.

(3) It was recommended that 2-ounce cans similar to the commercial can used by the 3-in-1 Oil Company be used as containers instead of bottles. This can be accomplished without change in the regulations prescribing the amount of the allowance. It was further recommended that a sub-note be inserted in the proper place under Note No. 31 to the effect that "In the field, one-sixth of the allowance of gun oil prescribed above for every six months will be issued automatically every seven days as part of the ration allowance." An appropriate change in present regulations prescribing issue of ration allowance to troops in the field should be made to accomplish the desired result.

d. Project No. 89. Range Correction Ruler for 6-inch Guns, Muzzle Velocity 2600 f/s.—This was submitted direct to the Board by Major Clifford Jones, C. A. C.

(1) Referring to Figure 1, it will be seen that the device consists of two identical scales, one on the base (B) and the other on the slide (S), and a sliding index with reading wire (I). The scales are constructed so that the distance between any two successive 1000 yards graduations is inversely proportional to the abscissa of the ± 150 foot velocity curve on the range chart for the 6" gun, measured at a point midway between the ranges being considered.

(2) The board is operated by applying the flat correction given at any range by moving the slide until the corresponding corrected range on the slide is opposite the uncorrected range on the base and thereafter reading corrected ranges from the slide opposite the uncorrected ranges on the base without further movement of the slide until additional corrections are applied. This insures a flat correction applied at one range being increased or decreased practically the same amount that would have resulted from applying the correction through the velocity curve on a range correction board.

(3) The Coast Artillery Board findings were:

(a) The range correction ruler gives a quick, and practical means for converting flat corrections into velocity corrections for 6-inch gun batteries not supplied with range boards.

(b) That drawings adapting this device to all rapid fire guns, not provided with range boards, can be made.

(c) That the accuracy is deemed sufficient, the deviations from range table values varying from zero to a maximum of 15 yards.

(d) That the needs of the service are met by a publication of a description of this device in the COAST ARTILLERY JOURNAL, and the supply of proper blueprints by the Coast Artillery Board to battery commanders on request.

(e) That a device for applying corrections as a percentage of the range is more readily constructed than the device submitted by Major Jones. The range correction board velocity curves and the percentage curves are very similar. Corrections applied through either will give approximately the same result. The Coast Artillery Board believes that for rapid fire batteries not supplied with range boards, the method of applying corrections as a percentage of the range is satisfactory. (In this connection see paragraph 7, Section 7, C. A. Memorandum No. 4, Revised, dated January 15, 1923.)

(4) The Coast Artillery Board recommended:

(a) Drawings for the scales be prepared, blueprints of which are to be made available for distribution to the service on application to the Coast Artillery Board.

(b) That a description and sketch of the device be published in the *Coast Artillery Board Notes* of the COAST ARTILLERY JOURNAL.

(5) The above recommendations were approved by the Chief of Coast Artillery.

7. The Board has under consideration a fire control project for a battery of four 16-inch Howitzers emplaced at intervals of 350 yards, the distance from No. 1 to No. 4 guns being therefore about 1000 yards. The howitzers have all-around fire and use Case III only. Five base end observing stations are to be supplied at present. This number will be increased later to 16.

Inasmuch as the distance between flank guns is about 1000 yards, each gun must be furnished a separate range and azimuth, and the ballistic data for each gun therefore will be different. The use of two Cloke Plotting and Relocating Boards in the Central Plotting room and one at each gun will permit rapid change of base lines, changing target, or changing from a four gun battery to two or one gun batteries.

The system of fire control recommended by the Board provided for the following methods of firing the battery:

1st Method, Battery as a Unit

Data from any two base end stations will be used to operate in the central plotting room one of two Cloke Plotting and Relocating Boards from which basic data referred to a convenient directing point will be transmitted to the guns. At each gun these data will be relocated on a Cloke Plotting and Relocating Board, the prediction made, ballistic and fire corrections applied and the corrected data then set on the guns.

A second Cloke Board in the central plotting room, using a different base line, is manned and tracks the next target. When the first target is destroyed or passes out of range the second plotting board immediately sends out data for the new target.

In this case deviations may be determined on a spotting board in the central plotting room.

2nd Method, Battery as Two Units

Plotting board No. 1 in the central plotting room furnishes basic data for guns No. 1 and No. 2 and plotting board No. 2 furnishes basic data for guns No. 3 and No. 4, or vice versa. Deviations may be determined in the central plotting room as two spotting boards are provided therein, or spotting data can be routed direct to gun plotting rooms.

3rd Method, Battery as Four Units

Each gun using an appropriate base line fires as a complete battery.

4th Method, Battery as Two Units

Two base lines are used for the battery, one base line being routed through to No. 1 and No. 2 gun plotting rooms, which operate in parallel while the other base line is routed through to No. 3 and No. 4 in parallel. Deviations are determined in each gun plotting room.

Other Methods

Any gun plotting room acts as a central plotting room for any or all of the remaining guns, or combinations of this with methods 1, 2, 3, and 4, are used.

Control of the Battery

The control of the battery may be exercised from the switchboard room, adjacent to the plotting room, which is equipped as the command post of the battery commander. This station should be directly in charge of an officer who should exercise the routine control of the battery. The battery commander will be free to go where needed.

Station B₂ being centrally located with respect to the field of fire and observing

stations, should be commanded by an officer. Arrangement has been made so that control of the battery may be exercised from this station.

Each gun should be commanded by an officer assisted by a fire control officer and an emplacement officer.

An officer should be in charge of the power plants, power and communications of the battery. This officer should be in charge of the maintenance and operation of these elements and should have no other tactical assignment.

Each base end station should be manned by an observer, a spotter, and a reader.

Further details of organization should be worked out after personnel has been assigned to the battery.

Plotting Room Equipment

Complete set of plotting room equipment will be required in each gun plotting room. This is necessary since the battery is dispersed over a front of 1000 yards rendering it impracticable to use the same firing data for all guns.

If an attempt is made to determine data separately for each gun in the central plotting room with a single set of fire control apparatus it would be necessary to relocate on the same board for at least three guns (an operation involving a net loss of time of at least 15 seconds) and also to apply different ballistic correction to each set of relocated data, which would result in an indeterminate loss of time (as the ballistic correction devices for these guns have not yet been manufactured.)

If four sets of ballistic correction devices were installed in the central plotting room and four separate sets of data are transmitted, enormous confusion would result.

Other methods such as the use of a device to correct for gun difference and the application of a separate ballistic correction for each gun at the same time, have been considered and thought unsuitable.

The equipment for each relocating room should include the following:

- 1 Range Correction Board.
- 1 Deflection Board.
- 1 Fire Adjustment Board.
- 1 Set of Prediction Devices.
- 1 Wind Component Indicator.
- 1 Spotting Board.
- 1 Atmosphere and Velocity Slide Rule.
- 1 Cloke Plotting Board.

The equipment of the central plotting room should include the following items:

- 2 Cloke Plotting and Relocating Boards.
- 2 Spotting Boards.
- 2 Fire Adjustment Boards.

Changes from Standard System of Fire Control

The system of fire control outlined herein differs from the system which has for many years been standard in the Coast Artillery only in the following respects:

Provision is actually made for the use of several base lines, and for the formation of these lines out of any two observing stations attached to the battery.

This provision has heretofore been made to a somewhat indefinite extent and has always been considered a standard of perfection. Its adoption as a positive affair is made necessary in the case of these guns by the fact that the field of fire is too great in range and azimuth to be covered by a single base line, and by the fact that these guns can only fire Case III.

A central plotting room is provided from which data may be furnished to gun plotting rooms. This change is made necessary by the adopted scheme in

the case of this battery of security by dispersion and concealment if we are to fire the battery as a unit.

Provision is made whereby base lines or basic data may be furnished to railroad batteries that may be emplaced on the flanks.

This change is necessitated by the existence of such batteries, and is a matter of economy of observation stations and personnel. It does not and should not preclude the establishment by such railroad batteries in their normal way of their own field type of base lines under their own control.

8. Project No. 81. The following discussion of the effects of the earth's rotation on the deviation of projectiles has been approved by the Chief of Coast Artillery for publication in the COAST ARTILLERY JOURNAL.

The necessity for writing this paper became apparent when the instructors in the Coast Artillery School found that the results obtained based on the discussion in gunnery for Heavy Artillery, Part I, Chapter IV, did not agree with tabulated values in the Firing Tables for 8-inch Seacoast Gun, Model of 1888 MI. In Chapter IV of Gunnery for Heavy Artillery but one of the two principal effects is discussed.

Range and Deflection Effects Due to the Earth's Rotation

In considering the range and deflection effects which result from the earth's rotation, it must be borne in mind that the trajectory is calculated for standard conditions and is constructed with reference to fixed axes. This course is followed so that corrections may be applied at the battery, whatever the geographical position of the battery may be, or whatever atmospheric conditions may obtain at the time of fire. In other words, when a range table is to be constructed from a certain set of firings, the observed data are stripped of all effects due to non-standard conditions, which non-standard conditions include rotation of the earth. A condition of no rotation is assumed in order to render the corrections for rotation at any location as simple as practicable.

The effects of the earth's rotation were first included in our range tables during the World War. These effects were taken into consideration due to the increase in range of cannon in use and due to the need of greater accuracy in the determination of firing data.

The divergences in the travel of a projectile due to rotation of the earth are not observed when range table firings are conducted but are determined by mathematical considerations. It is assumed that the translation of the earth produces no divergence in the travel of projectiles, consequently only the motion of rotation is considered.

There are two principal effects of rotation on the trajectory of a projectile which are considered in computing range table data. These are, first, "lag," resulting from the increase of radius of rotation due to the height of the projectile above the surface of the earth, and second, the inclining of the base of the trajectory with reference to the fixed axes upon which the trajectory was computed resulting in an increased or decreased time of flight. This change in time of flight will, of course, in the general case, result in a divergence of the projectile.

The effects of rotation on the range and deflection of a projectile will now be considered. The instant before a gun (at rest with reference to the earth) is fired, the gun, projectile, earth's surface and atmosphere (wind neglected) have the same linear velocity. The projectile leaving a cannon has impressed upon it both the velocity due to the propellant and the velocity of the cannon through space. The linear velocity of the cannon through space, if we neglect the motion of translation of the earth, is due to the rotation of the earth about its axis and will vary as the cosine of the latitude of the cannon.

Consider a projectile fired due West in the plane of the equator. During its

flight, it is at a varying distance from the surface of the earth and hence from the center of the earth. These latter distances are all greater than the radius of the earth at the origin of the trajectory and point of fall of the projectile. Therefore, the projectile will lose in angular velocity due to its increased distance from the earth's axis of rotation, i.e., the earth with its greater angular velocity will turn from under the projectile, the projectile will lag and tend to fall farther to the westward than it would have done if the earth had no motion of rotation. In the case of a projectile fired to the East in the plane of the equator the projectile will lag and tend to fall to the westward of the point at which it would have struck provided there had been no rotation of the earth during the time of flight. In the case of a projectile fired to the North or to the South from the equator, the projectile will likewise lag and will fall West of the North and South line through the gun. Also in the case of a projectile fired vertically, the angular velocity of the gun on the earth's surface being greater than the angular velocity of the projectile at all points in its trajectory, the projectile will lag and strike at some point to the West of the gun from which it was fired. These examples illustrate the first or the "lag" effect of rotation.

The second effect, that is, the effect due to the inclination of the base of the trajectory, may be visualized as follows: Considering no rotation of the earth during the time of flight, the base of the trajectory would be in a plane perpendicular to the plane of fire, which perpendicular plane includes the point where the axis of the bore intersects the plane of the muzzle of the gun and the point at which the center of gravity of the projectile again reaches the same elevation, i.e., the same distance from the center of the earth. Or, expressed more simply, the base of the trajectory may be considered as a line joining the muzzle of the piece and the point of fall, which line is contained in a plane perpendicular to the plane of fire. Now if drift be disregarded this line may be considered straight and will serve as the X axis used in constructing the range table trajectory. But since rotation does occur during the time of flight at a constant angular rate toward the East, the line, which we have considered as the base of the trajectory of a projectile fired on a still earth, will also rotate, the eastern end tipping down and the western end tipping up, consequently a projectile fired on the rotating earth, to the East in the plane of the equator will travel a longer time to reach the datum plane containing the point of fall, or the base of the trajectory, than would the same projectile have travelled had it been fired on the earth without rotation. For a projectile fired to the West in the plane of the equator, considering the earth to have a motion of rotation, the time of flight will be shorter than for the same projectile fired on the still earth due to the tipping up of the datum plane. This effect is shown graphically in Figure 1 (a).

In this figure two trajectories are shown. Trajectory "A," shows the path of a projectile fired at a moderate angle of elevation; trajectory "B" shows the path of a projectile fired at a high angle of elevation. The axes OX and OY may be considered as fixed in which case the trajectories will be range table trajectories (assume standard conditions existed at time of firing.) If we now consider that the earth rotates through the angle α during the time of flight and assume that the gun was pointed due west, the position of the axes will be OX_1 and OY_1 . In considering this figure it should be borne in mind that the gun, atmosphere, and earth's surface move together. When the projectile has cleared the muzzle blast, the only forces acting on it are the force of gravity and resistance of the atmosphere. An inspection of the figure shows the effect of rotation on the coordinates of the trajectory. The effects are greatly magnified due to the large rotational angle assumed. It will be noted that the maximum ordinate in each trajectory is reduced. Since gravity is the force that causes the projectile to fall again to the earth after it has reached the maximum ordinate, it will be

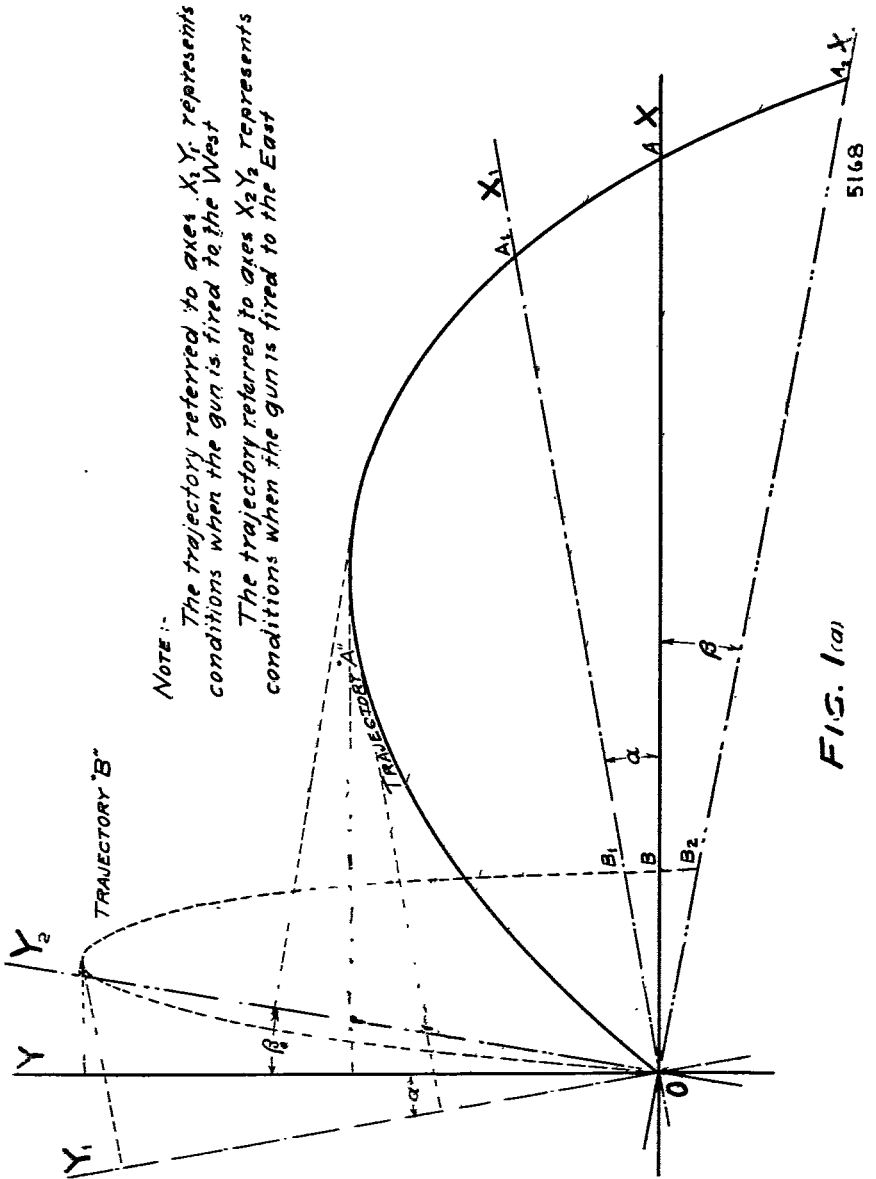

NOTE:-
 The trajectory referred to axes $X_1 Y_1$ represents conditions when the gun is fired to the West
 The trajectory referred to axes $X_2 Y_2$ represents conditions when the gun is fired to the East

FIG. 1(a)

seen that the gravity will have to act for a shorter length of time to bring the projectile to the datum point (point of fall) when the axes have been revolved through the angle α than would have been the case had there been no rotation.

In trajectory "A" this shortening of the time of flight results in a reduced range, OA_1 being shorter than OA , while in trajectory "B" the shortening of the time of flight results in an increase in range, OB_1 being longer than OB .

By referring the trajectories "A" and "B" to the axes OX_2 and OY_2 the effects of a rotation of the earth during the time of flight equal to the angle β on the flight of projectiles can likewise be shown geometrically. This will serve to illustrate the conditions when the projectile is fired to the East. In this case the maximum ordinate and the range are increased for both the trajectories shown.

The relative values of the deviations due to "lag" and that due to inclination of the base of the trajectory may be visualized by plotting the horizontal and vertical components of the velocity of the projectile as a function of time. In figure 1 (b) the horizontal and vertical components of an actual trajectory are plotted but the corrections applied are to a multiplied scale, that is, a rotation faster than that of the earth is assumed.

The time of flight is that time which corresponds to a zero area under the vertical velocity curve. In other words the time of flight is the elapsed time between the departure of the projectile from the muzzle and the return of the projectile to a point at the same distance from the center of the earth as the muzzle of the piece (point of fall.) The projectile whose velocity components are plotted in the figure will reach a zero elevation when the area under the positive portion of the vertical component curve is equal to the area under the negative portion of this curve. This is equivalent to saying that the projectile will be at zero elevation when it has fallen as far as it went up. The horizontal range is the area under the horizontal component curve to the point in the X axis equal to the time of flight.

The corrections applied to the horizontal component (the lag correction) will depend upon the height of the projectile above the surface of the earth and will be for any position, Y , (the ordinate) multiplied by the rotational factor. The corrections to be applied to the vertical component of velocity due to rotation of the earth at any point in the trajectory will depend upon the distance of that point from O on the X axis in Figure 1 (a) (the abscissa) and will be X multiplied by the rotational factor. Now since the ordinate at the origin of the trajectory and at the point of fall is zero, the correction for rotation applied to the horizontal component will increase from zero at the origin to the maximum ordinate, where the correction will decrease from this maximum to zero at the point of fall. Since the range or abscissa increases throughout the trajectory the corrections to be applied to the vertical component of the velocity will increase from the origin to the point of fall. The area shown double crosshatched between the curve "horizontal components of velocity, no rotation," and the curve "horizontal components of velocity corrected for rotation" is the effect due to lag. The single crosshatched area shown under the horizontal component of velocity curves, no rotation, is the effect due to the rotation of the base of the trajectory (X axis) and the consequent reduction in time of flight (the gun having been fired to the West). The latter effect is greater than that due to lag.

Taking the case of the 8-inch seacoast gun at an angle of elevation of 20 degrees where the table gives a net effect of 57 yards, the effect due to the rotation of the X axis is 58 yards, and that due to lag (rotation of the Y axis) 1 yard, but with opposite sign. For angles sufficiently high the X axis effect will become less and the lag effect more so that the net effect will even change sign. This change in sign will occur at about 60° elevation.

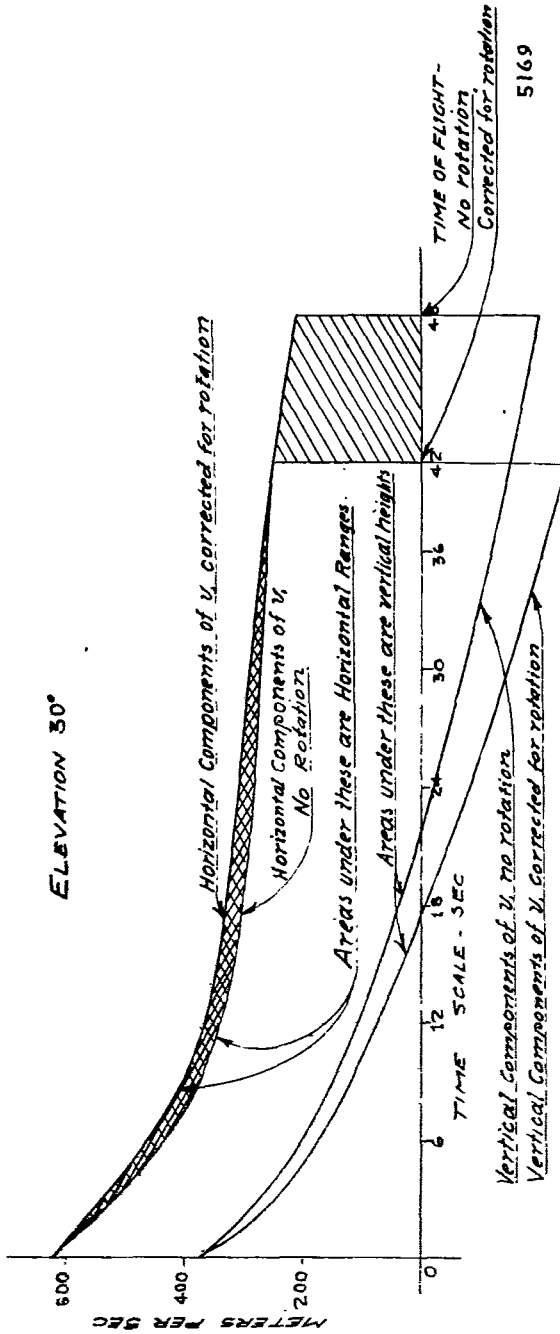

FIG. 1(b)

EFFECTS ON RANGE DUE TO ROTATION OF THE EARTH

ELEVATION 45°

NOTE: Coordinates are from a trajectory of a 12" mortar fired westward on the Equator ω assumed as 0.01 Rad/Sec.

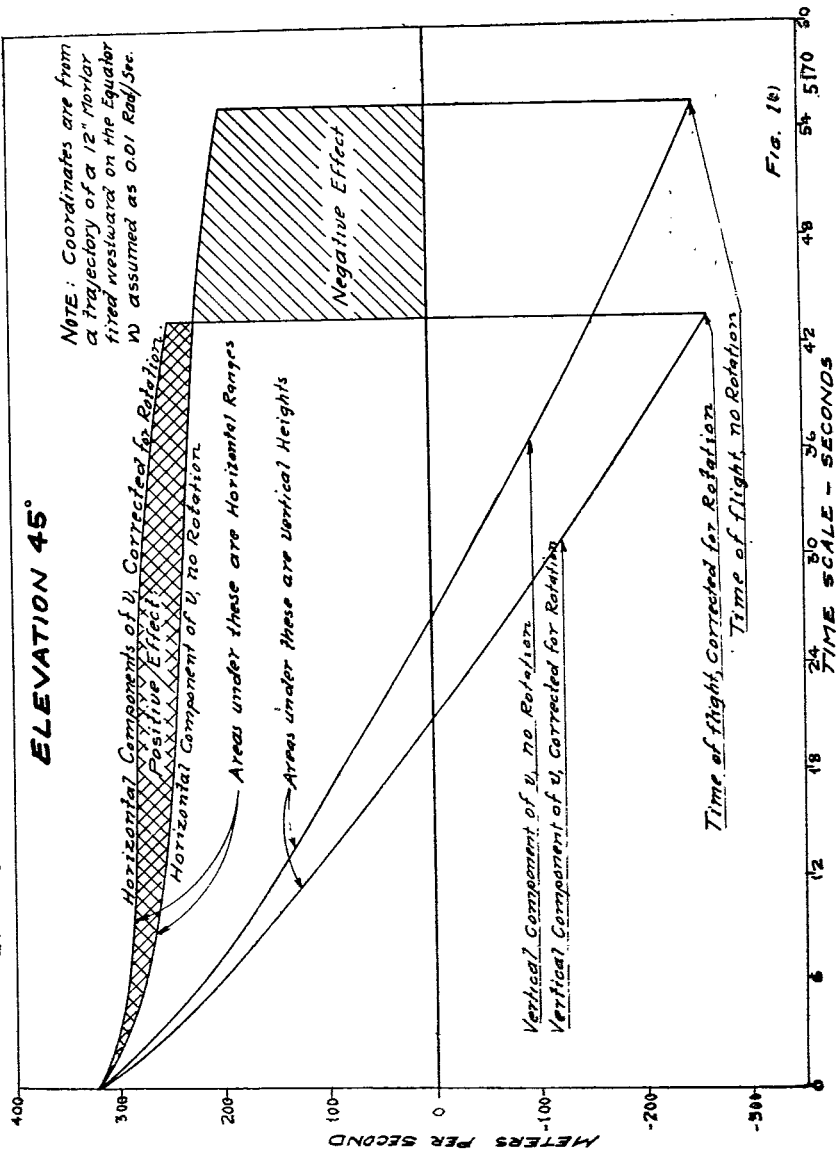
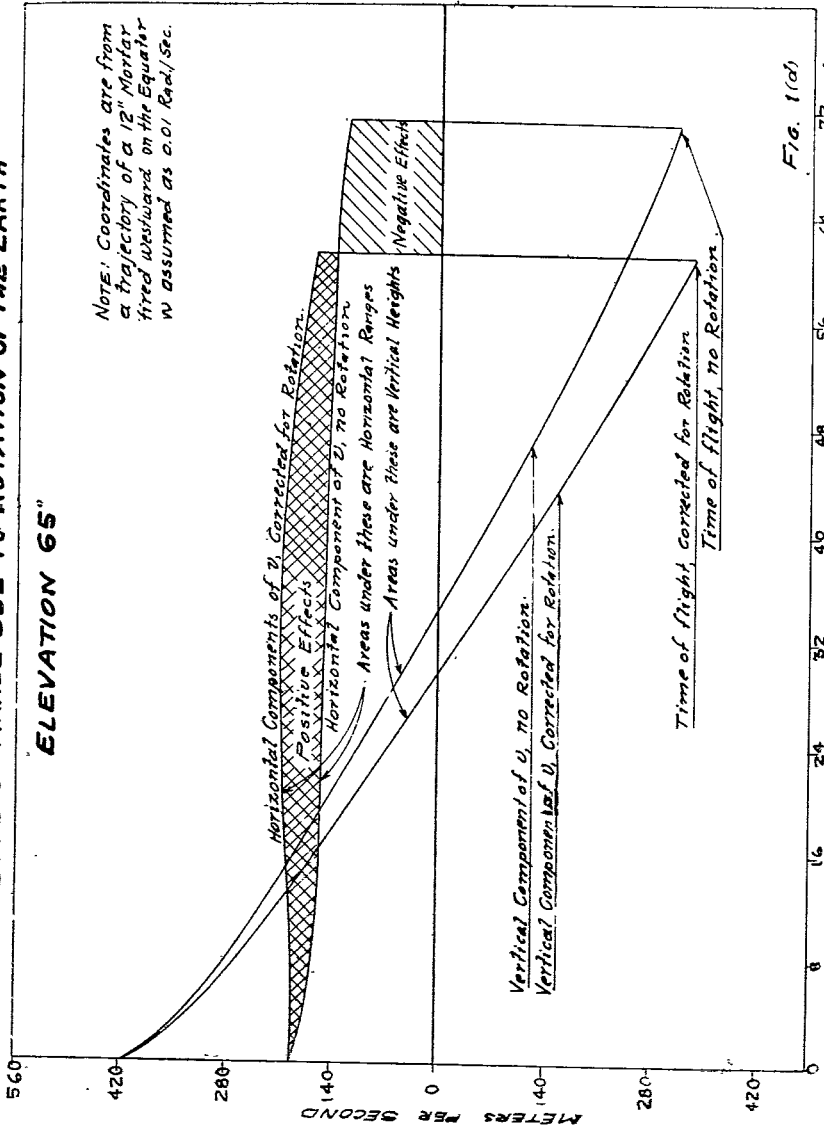

Fig. 1(c)

EFFECTS ON RANGE DUE TO ROTATION OF THE EARTH

ELEVATION 65°

NOTE: Coordinates are from a trajectory of a 12" Mortar fired westward on the Equator W assumed as 0.01 Rad./sec.



Horizontal Components of V , Corrected for Rotation.
Positive Effects
Horizontal Component of V , No Rotation

Areas under these are Horizontal Ranges
Areas under these are Vertical Heights

Negative Effects

Vertical Component of V , No Rotation.
Vertical Component of V , Corrected for Rotation.

Time of flight, corrected for Rotation.
Time of flight, no Rotation.

Fig. 1(d)

Figure 1 (c) shows the range effects due to rotation of the earth in the case of the 12-inch mortar fired with the 700 lb. projectile and 1500 f/s muzzle velocity at an angle of elevation of 45 degrees, assuming that the mortar is fired westward at the equator and that the earth is rotated at the rate of .01 radian per second, or much faster than its actual rate. This faster rate is assumed in order that the effects may be plotted to a relative scale and still show in the figure. Figure 1 (d) shows the range effects of rotation of the earth when the same piece is fired under the same conditions as stated above except that the elevation angle is increased from 45° to 65°. In comparing the two figures it will be seen that the total range effects are of different sign, the total effect at 45° elevation is negative while at 65° elevation the total effect is positive.

In addition to the effects discussed above, the range tables may take into consideration the effect caused by the change in air resistance due to rotation. The air, of course, rotates with the rotating X and Y axes, see Figure 1 (a), so that new velocities with respect to these axes must be considered in entering the resistance function. This secondary effect is hardly noticeable in the 8-inch gun, but is of such magnitude as to require consideration in the case of a gun having a range of 75 miles.

Other minor effects of rotation are neglected in making up the range tables.

The general case of firing a gun at any point on the earth's surface in any direction will now be considered.

If a projectile be fired in a plane perpendicular to a meridian from a point either north or south of the equator, the range effect of the earth's rotation will be of the same nature as though the projectile had been fired in the plane of the equator, but the magnitude of this effect will vary as the cosine of the latitude, since the component of the angular velocity in the plane of fire varies as the cosine of the latitude.

In the case of a projectile fired in the plane of a meridian the effect of the earth's rotation would be to make the projectile fall to the west of meridian. If firing north this will be to the left of the plane of fire, if firing south to the right. Thus the effect will be wholly one of displacement perpendicular to the plane of fire and no range deviation will result.

When firing in planes neither in the plane of the meridian nor perpendicular thereto, deviation both in range and perpendicular to the plane of fire evidently will result. If we measure the azimuth, "A," of the plane of fire from the south point through the west, these deviations will be proportional respectively to $\sin \alpha$ and $\cos \alpha$. Also both of these deviations will depend upon the range, time of flight, shape of the trajectory, effect of air resistance and the velocity of rotation of the earth. We may then express the effects resulting in these cases as $\Delta X = -A \cos l \sin \alpha$, and $\Delta Z = +C \cos l \cos \alpha$, where ΔX is the range effect, ΔZ the deflection effect in linear units, l the latitude of the point and A and C are functions of the factors just given. These effects result no matter what the azimuth of the plane of fire. In the plane of equator $\Delta Z = 0$; in the plane of a meridian $\Delta X = 0$.

There is another deflecting cause that must be taken into account. Let us consider all directions to be expressed in azimuth values; azimuth having the meaning defined above. The origin line for any such direction angle is evidently the tangent to the meridian passing through the cannon. The rotation of the earth causes such a line to generate either a cylinder, a cone or a plane depending upon whether the cannon is on the equator, between the equator and a pole or at a pole. Only when the cannon is on the equator are successive positions of such a line parallel. It is evident therefore that the rotation of the earth actually causes the direction in space of the line joining the cannon and the target to change while the projectile is in the air and thus causes a lateral deviation of the projectile

from the point aimed at, which is equivalent to a deviation from the plane of fire. It can be shown that this change of direction is dependent upon only the latitude and that it is not affected by the azimuth of the plane of fire. The effect in this case is $+B \sin l$ where B is a function of the angular velocity of rotation of the earth, the range and the time of flight.

The complete deflection effect in yards that results is, therefore, $\Delta Z = +B \sin l + C \cos l \cos a$.

The expression $+C \cos l \cos a$, reduces to zero when firing in a plane perpendicular to the meridian, is negative when firing north of such a plane in both the northern and southern hemisphere and positive when firing south of such a plane. The expression $(+B \sin l)$ is always positive in the northern hemisphere and negative in the southern. It is an effect which results from the projectile deviating to the right of the plane of fire in the northern hemisphere and to the left in the southern.

The term $\Delta Z = +B \sin \varphi + C \cos \varphi \cos a$ applies only when the direction angles of the plane of fire are measured as here assumed, i.e., clockwise from the south point of the true meridian. These effects are thus directly applicable to the azimuth used in pointing our fixed cannon. When Y-azimuths are used, i.e., azimuths measured from a North point on the Y-line, the expression for the deflection effect becomes $+B \sin l - C \cos l \cos a'$, a' being the Y-azimuth of the plane of fire. The correction of a' for the inclination of the Y-line to the true meridian will seldom, or never, be necessary. A negative effect indicates that the azimuth (or Y-azimuth) must be increased and a positive effect that the azimuth (or Y-azimuth) must be decreased.

The range effect term $\Delta X = -A \cos l \sin a$ is, except for very high elevations negative when firing west of the meridian in the northern hemisphere and positive when firing east of the meridian. The same is true in the southern hemisphere. Like the deflection effect term, this effect is directly applicable only when azimuths are measured from the south point of the true meridian. When Y-azimuths are used the expression becomes $\Delta X = -A \cos l \sin a'$, where a' is the Y-azimuth of the plane of fire.

The factors B and C are always positive. The factor A is positive for small angles of elevation and may be negative for extremely high angles of elevation. The elevation at which A changes sign varies with different cannon. These factors will be listed in the range tables for those cannon whose ranges are such as to demand that corrections be made for the deviating effects of the earth's rotation.

The term "range table" has been used in the revision of this chapter in place of the accepted term "firing table" in order that the terminology used throughout the text will be uniform.

Attention is invited to the use of "effects" instead of "corrections" in this discussion. It is now the established custom to tabulate effects instead of corrections in firing tables. The signs of the terms of the equations would be reversed were "corrections" considered.





Employment of Heavy Artillery—Problem No. 10—A Solution

1st Requirement:

On receipt of FO No. 7, Maj A first works out his firing schedule. From the nature of the targets assigned and the times at which they are to be engaged, he concludes that the batteries are to be neutralized, the strong points destroyed, and the RJ interdicted. In order if possible to gain surprise effect on the hostile battery personnel before they can take cover, he arranges to open on each battery with a rapid burst of fire. Then as his fire will have to be unobserved until daylight, he reduces the rate so as to conserve ammunition until daylight, then increasing the rate of fire in the hope of effecting destruction as well as neutralization. In engaging the strong points, Maj A decides to use half the ammunition allowance in an attempt at destruction, reserving the remainder for harassing fire over the rest of the assigned period. To handle the interdiction of Target XXV with the assigned allowance, one mortar is told off to engage it with 11 rounds per hour, varying the rate of fire so that the enemy cannot predict the time of arrivals.

FIRING SCHEDULE No. 10 1ST BN 901ST ART

<i>Battery</i>	<i>Target</i>	<i>Rate of Fire</i> <i>rd's per gun</i> <i>per hr.</i>	<i>From -</i>	<i>To</i>	<i>Remarks</i>
B (1 plat)	XII	10	H-6	H-1	Max. rate for 1st 4 shots each gun, with superquick fuses, there- after use short delay fuses.
		15	H-1	H+1	
B (1 plat)	XIV	10	H-6	H-1	superquick fuses, there- after use short delay fuses.
		15	H-1	H+1	
A	XVI	5	H-6	H	Short delay fuses.
		10	H	H+1	
B	XXII	15	H+1	H+2:20	Short delay fuses.
		3	H+2:20	H+8	
A (3 guns)	XXIV	20	H+1	+2:20	Short delay fuses.
		4	H+2:20	H+8	
A (1 gun)	XXV	11	H+1	H+8	Superquick fuses. Fire at irregular inter- vals.

Maj A then takes his Executive, Adjutant, Orienteur, Plans and Training Officer, Signal Officer and Battery Commanders, for a careful reconnaissance of the trackage at the GRANITE HILL siding, and along the main line between the old and new positions. Finding that but 7 mortars can be accommodated, even with crowding, on the new siding, he decides to leave one mortar of Btry B at its present position, reporting his decision in due time to Gp Hq. The mortar to be left behind is the most *westerly* one in Btry B's present position, as in picking up the others with the ammunition cars, to make up the firing train, the locomotive will thus be able to handle the train from behind.

In assigning positions, Btry A, now on the main line, will go in ahead, followed by 3 guns of Btry B. Each Btry train will be made up with a tool car before and behind, and with an ammunition car following each mortar.

Already having a Bn OP on GRANITE HILL, connected by wire to the old Bn CP, Maj A decides to retain this one OP for the Bn and batteries, and directs the Signal Officer to establish switchboard at GULDENS, and after the forward displacement to salvage the lines between the 3 present OP's, and from each Btry OP back to its Btry CP, as well as the lines from old Bn CP to old Btry CP's. Communication to Gp C Hq by present field lines through NEW OXFORD central.

Maj A designates new CP's as follows: Bn at GULDENS, Btry A at CR517, Btry B at GRANITE HILL STA.

Bn Radio and Aid Stations at GULDENS, Rear Echelon at present Btry B position, changes to be effected when ordered by Maj A.

After having noted repairs to trackage which will have to be made, Maj A directs the Btry Commanders to arrange the necessary details from Btry personnel, under the Btry Executives, to repair the track at the new positions, these details to be sent up by truck each night before D day, if necessary, and on D day as soon as March Order has been executed at the old positions. Maj A also directs the Plans and Training Officer to arrange with the Engineers, through Hq Gp C AA, for the repair of the main line trackage, to secure permission from Gp C Hq for the use of siding at GULDENS for fire control and ammunition cars, and to secure the necessary camouflage and track materials for the preparation of the new position.

Maj A directs the Orienteur to lay out the orienting line for the new positions, and the Adjutant to arrange for the establishment of the new Bn CP and the subsequent closing of the old. He arranges a patrol of the Scouts and Agents to patrol the trackage on D day so as to keep him informed as to any damage that might occur through hostile shell fire.

2nd Requirement:

Having been informed by his track patrol that the main line is clear and passable, Maj A commands March Order for Btry A and directs by phone to the Rear Echelon that the switch engine proceed at once to make up Btry A train and push it to the new position. The Btry Exec and his detail proceed to the position by truck as far as the road permits.

Maj A sends the Adj and P and T officer forward with the personnel to open the new Bn CP.

As soon as Btry A train leaves, Maj A directs Btry B to cease firing and march order with the 3 guns which are to move.

When the new Bn CP reports ready to open, Maj A orders the old CP to close; reports by phone to Gp C Hq the change of CP's, requests new firing orders, and goes ahead to the new positions. As soon as he sees that their organization is proceeding satisfactorily, he leaves the Bn Executive at the new CP in charge of the Bn, and starts forward, by motor and on foot, with the Signal Officer and 1st party to find a new advanced OP ahead of the old front line.

Employment of Heavy Artillery—Problem No. 11

References. Maps, Gettysburg 1-inch, and Gettysburg 3-inch, Bonneauville, Gettysburg, Arendstville and Knoxlyn Sheets, also Gettysburg General Map.

General Situation:

In continuation of Problems 1, 3, 5, 7 and 9.

The attack of 7 May carried the entire hostile front lines. On 8 May HERR RIDGE and OAK RIDGE were carried and the enemy were driven back to the line (SUGAR LOAF HILL—CARR HILL—SEVEN STARS—TABLE ROCK—HEIDLERSBURG.)

This line was attacked on 9 May and a heavy repulse was sustained by the Blue Army but no ground was lost. On the evening of the same day a message was received from the Air Service that enemy troops were crossing Susquehanna at MT. WOLF and WRIGHTSVILLE.

On 11 May report was received from the Cavalry covering the right of our Army that they were falling back from YORK before superior hostile forces. Reports of prisoners indicated the presence of at least 3 Red Corps.

The cavalry was withdrawing on HANOVER JUNCTION.

Special Situation (Blue):

The 1st Bn 701st Artillery had gone in position in vicinity of KATALYSINE SPRING (347.5-750.5) from which position it had supported attacks of 9th of May. Its rear echelon was at LUTH. T. SEMINARY. The following is extracted from an order from Brigade Headquarters received by Maj A at 11:00 AM, 11 May:

Field Order } No. 16	301st FA Brig BOYD S H 11 May 8:00 AM
-------------------------	---

Map: GETTYSBURG 3-inch or 1-inch reduced from 12-inch War Game Map.

1. All attempts of enemy to regain ground lost by him on 8th and 9th have been decisively beaten back. The enemy's 2d Army has crossed the SUSQUEHANNA and is now about YORK. Our 3d Army has arrived at WESTMINSTER. The III Corps withdraws to a line of principal resistance LITTLES RUN—TWO TAVERNS—ASH GROVE S H—TOLL GATE pursuant to the orders of 1st Army as part of a strategic refusal of our right wing to make contact with our 3d Army.
2. The withdrawal of the III Corps to the new position will be completed by 6:00 AM, 12th May, except for the 8th Division, which will cover the withdrawal of the Corps and which will hold the present position of principal resistance until 6:00 AM, 12th May.
3.
 - a.
 - b.
 - c.
 - d.
 - e. The 1st Bn 701st Artillery will withdraw immediately to new positions in vicinity of CONOVER FARM, center of its field of fire, BONNEAUVILLE. It will clear present position and be south of HAGERSTOWN ROAD by 2:30 PM.
 - x. CHAMBERSBURG ROAD and the BALTIMORE TURNPIKE are reserved for Infantry troops and trains. Heavy artillery will not pass through or to the north of GETTYSBURG, but may use the extreme west and south streets in clearing this area. All heavy artillery will be east of WILLOUGHBY RUN by 3:00 PM.

* * *

New positions will be prepared for defense.

* * * *

2 Days of fire will be dumped at battery positions, using Bn Comb Tns.

*

Evacuation of sick and wounded by heavy artillery organizations direct to TANEYTOWN

5. BHQ closes here at 7:00 PM this date and opens at KINGSDALE same hour.

* * * *

Assume that the following motor vehicles are at the Rear Echelon: all pertaining to Bn Hq and Hq Btry; Bn Comb Tn; Bn Sect Serv Btry; Med Det; and all pertaining to Btry A and Btry B except 1 tractor and 1 motorcycle per btry, the AA trailers, kitchen trailers and water trailers.

1st Requirement:

Maj A's choice of route to the new position, with discussion of reasons therefor.

2nd Requirement

Maj A's detailed plans and orders for the withdrawal, march and occupation of new position.

THE COAST ARTILLERY?

YES!

NOW—AND ALWAYS

THE ARM OF POWER

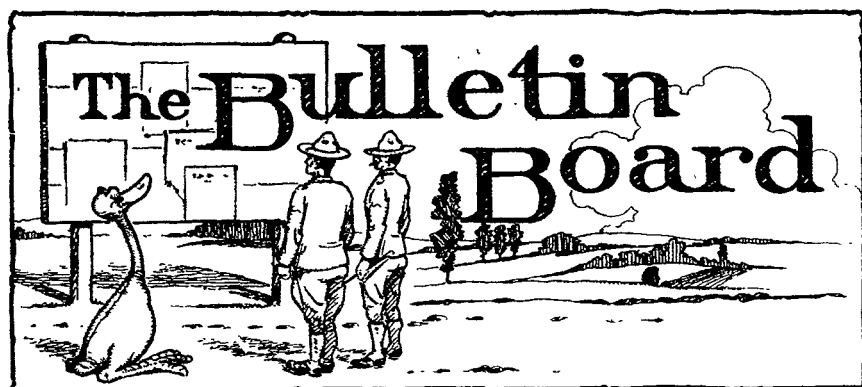

Reunion of 67th Artillery, C. A. C.

Former Officers and Enlisted Men of the 67th Artillery, C. A. C., U. S. Army, which was commanded in France by Colonel Joe Wheeler, Jr., gathered at a luncheon in San Francisco on March 28th, 1923, and formed an Association. The following temporary officers were elected. Chairman, Colonel R. E. Mittelstaedt, Secretary, Captain A. T. Emerson, Executive Committee, Captain A. P. Conklin, Captain B. B. Brown, and Warrant Officer Harry C. Payson.

It is intended to hold a reunion dinner in the near future at which time a permanent organization will be perfected. All former members are requested to communicate with Captain Emerson at the State Armory, San Francisco, giving their addresses.

The C. A. Unit at the University of California

The youngest Coast Artillery Unit among the various Colleges and Universities, is at the University of California and judging from the reports we receive, it is rapidly making a place for itself among the other units at the U. of C. and in the regard of the student body.

The California Engineer says:

One of the new features of Engineer's Day will be the Coast Artillery Unit's *Open House*. At the beginning of last semester the unit was formed at the University under the command of Captain C. D. Y. Ostrom, C. A. C. All men in the College of Mining and Civil Engineering were assigned to it. So interested in the work have these men become they have decided on an exhibition of some phases of it for the benefit of the University public.

Many will be surprised to learn that where the "Joint" used to be in the old North Hall, the Coast Artillery Unit has established a 15,000 yard range for fire control drill. A telephone system has been installed and everything connected with a large battery is duplicated. In these quarters the "Coast Artillerymen" will receive their friends

Much credit is due Captain Ostrom for the work he has done in getting the equipment for the unit. As a result of his efforts it has received a complete set of fire control instruments and accessories This equipment will be shown and explained during the afternoon in the North Hall."

The significant thing in this news item is the fact that Coast Artillery *esprit* has been aroused in this group of college men to the extent that they are willing to put in voluntary effort to boost the Coast Artillery game. A real measure of success in R. O. T. C. work is the degree of spontaneous loyalty to the Coast Artillery which may be inspired in the undergraduate enrollment.

BOOK REVIEWS

Map Reading and Military Sketching. By Lieut. Col. P. S. Bond, C. of E. The American Army and Navy Journal, Inc. New York. 1922. 6" x 9". 104 pp. Cloth. Price, \$1.25.

This book presents the important subjects of map reading and sketching in a most pleasing and comprehensive manner. The text is arranged as a series of lessons of suitable length, progressing logically from the simple fundamentals to the complete procedure of making a finished sketch. There are four lessons in map reading and twelve lessons in military sketching and throughout the book there are some fifty drawings which greatly aid the student.

There are many books on this important subject but this is the latest and most up-to-date work that has come to our attention.

Infantry Drill Regulations. By Major E. B. Garey, Infantry, and O. O. Ellis (formerly) Major of Infantry. The American Army and Navy Journal, Inc. New York, 1922. 6" x 9". 157 pages. Cloth. Price, \$1.25.

The purpose of this volume is best stated by the authors: "To make each movement of the Infantry Drill Regulations perfectly clear and simple to the beginner, by explanation, picture, and diagram; and to point out common mistakes to be avoided * * * and to explain for the benefit of the instructor, the method of training used by successful drill inspectors."

The authors have accomplished their purpose, and have prepared an excellent contribution to the military library of any officer or enlisted man. From the school of the soldier through the school of the regiment, the reader is conducted in a manner which is pleasing as well as instructive.

The text like the others in the set, is arranged in lessons, and is plentifully illustrated with drawings and diagrams.

Scouting, Patrolling and Musketry. By Lieut. Col. P. S. Bond, C. of E., and 1st Lieut. E. H. Crouch, Infantry. The American Army and Navy Journal, Inc. New York. 1922. 6" x 9". 287 pages. Cloth. Price, \$1.50.

This volume is the only one of the set which is primarily an Infantryman's guide. However from the standpoint of broadening one's horizon, this text, which is a thoroughly practical course, containing forty-five figures and diagrams, a questionnaire for each lesson, and thirty-two practical exercises and problems, is the latest work on a most important subject, and well worth owning.

Tactics, The Practical Art of Leading Troops in War. by Lt. Col. P. S. Bond, C. E., and 1st Lieut. E. H. Crouch, Inf. New York. The American Army and Navy Journal, Inc. 1922. 6" x 9 1/4". 486 pp. Price, \$2.75.

The purpose of this volume, as stated in the preface is to set forth in a practical and comprehensible manner the simple, definite and standardized doctrine of tactics, especially infantry tactics, which has been recently developed by the U. S. Army as a result of our experiences in all wars. Realizing that the brunt of the actual attack and the shock of battle will be met by the enlisted man and the younger officer, the authors have very wisely and very ably prepared this text with the realization that clarity and simplicity are of paramount importance.

The book is arranged in lessons of which there are thirty-eight in number, and in addition there are one hundred pages of practical exercises and seventy-four pages of appendices. Every problem in minor tactics of Infantry which could possibly confront the junior commander is carefully presented and as carefully worked out. Many diagrams, "march graphics" and plates add to the ease of comprehension of the book and to its general value. It is a book of real value to any student of the art of commanding troops in combat.

Field Engineering. By Lieut. Col. P. S. Bond, C. of E. The American Army and Navy Journal, Inc. New York. 1922. 6" x 9". 161 pp. Cloth. Price, \$1.50.

A great many books have been written on Field Engineering and many different people have had a lot to say on the subject with the natural result that there was much room for standardization. The subject was needlessly complicated by a variety of terms and symbols which were inconsistently used.

The recent war has greatly altered the opinions of everybody as to the need for field engineering and the use of the various types of entrenching tools, and how to make the most of a bad situation. Colonel Bond in his text takes the student through all of the intricacies of all the phases of field engineering in fifteen lessons. The text is carefully and logically arranged with some sixty-eight illustrations and plates to make easier the way of the student. This book is a splendid addition to any officer's library.

The Giants of the Marne. A Story of McAlexander and His Regiment. By Major Jesse W. Wooldridge, 38th Inf. The Seagull Press, Salt Lake City. 1923. 6¼" x 9¼". 120 pp. Ill. Flexible Cloth. Price, \$1.50.

This little book is a devoted and enthusiastic account of the share of the 38th United States Infantry in repelling the attempt of the Germans to cross the Marne beginning July 15, 1918. The heroic exploit of this Regiment has already become widely known as an outstanding classic in American military annals. The author, who commanded Company G of the 38th Infantry during the German attack, makes the claim that the achievement of this Regiment is clearly the most notable accomplishment of any American unit. Even making all due allowances for his enthusiasm and for his loyalty to his Regiment and his Colonel, it may well be that his contention will be supported as the verdict of history.

The 38th Infantry was the right Regiment of the Third Division, with the 30th Infantry on its left and with the French 131st Regiment on its right. The Germans threw nine regiments across the Marne in front of the 38th Infantry, and due to the fact that both the 30th Infantry and the French 131st Regiment fell back, the 38th withstood alone and unsupported this concentrated attack for more than three days, fighting to the front and on both flanks. The indomitable spirit which was instilled into the officers and men by Colonel (now General) McAlexander, the wisdom of the preliminary disposition of the Regimental Commander, and the remarkable tenacity and heroism of all ranks, are clearly brought out in the detailed account of Major Wooldridge.

While his preliminary chapter purporting to set forth the condition of the Allies at the date of this attack will not stand historical analysis in view of the historical material which is already at the disposal of the military student, yet the significance of the performance of the 38th Infantry is not at all minimized by this fact, and it is fair to believe that the detailed story of the operations of the 38th Infantry itself is accurate and to be relied upon.

A particular interest attaches itself to this book and its story so far as the reviewer is concerned by reason of the fact that he is a friend and classmate at Norwich University of Major Guy I. Rowe, who commanded the forward Battalion of the Regiment, and whose conduct of his share of the defense won him the Distinguished Service Cross and the admiration of every officer who has had an opportunity to become conversant with the facts. The heroism and cool judgment of Major Rowe have reflected an undying lustre not only on his own name, but on Norwich University and the little state of Vermont from which he came.

In the few days covered by this book, the 38th Infantry lost 2917 officers and men, a fact which in itself should commend the book to every American

who needs to have his confidence confirmed in the valor and steadfastness of the American soldier.

The Official History of the Great War. (Military Operation—France and Belgium.) Compiled by Brig. General J. E. Edmonds, C.B., C.M.G. (Retired) p.s.c. Macmillan and Company Limited. London. 1922. 5½" x 8½". 543 pages. Cloth. Price, \$8.00.

This history, as the author states in his prefatory remarks, was compiled for the specific purpose of providing an authoritative account of the events from the time of mobilization up to the middle of October, 1914, a period of two and one-half months, in such a form as to be suitable for the general reader and for students at the service schools. It is based upon official British records to which the author had access during its compilation.

Bearing in mind what a tremendous amount of official, semi-official and private documents must have been written during those frenzied times, the reader is impressed with the realization that the author has not only accomplished his purpose, but in so doing has prepared a lasting and accurate chronicle of the first few weeks of the great war which will be of inestimable value to the student of military history as well as the casual reader.

This volume has been wisely prepared with an eye for "ready reference" after the initial reading. Appropriate map references together with dates of events narrated on each page, appear in the margins. German formations and units are italicized, to distinguish them clearly from the Allies. Cross references are frequent and appear as foot-notes. Two and even four color charts of defensive areas add greatly to the understanding of the text.

General Edmonds has obviously sifted the wheat from the chaff in extracting the personal element which is bound to creep into a report of experiences or impressions, so much so that the reader is conscious of a constant endeavor to avoid the superlative which is at times a little aggravating, but a sure sign of a true Britisher. The most tense episodes are narrated in a very matter of fact way which is undeniably becoming to a great soldier, but exasperating nevertheless. Such a criticism is very trivial however, and in no way decreases the exceptional value of the book. It is a splendid contribution to the long line of military histories of the world.

The Easy Course in Home Radio. 7 Pamphlets. Edited and approved by Major General George O. Squier, Chief Signal Officer, U. S. Army. Review of Reviews Co. New York. 1922. 4¾" x 6¾".

A set of seven pamphlets with the following titles: 1. A guide for listeners in. 2. Radio simply explained. 3. Tuning and what it means. 4. The Aladdin's lamp of radio. 5. Bringing the music to the ear. 6. How to make your own parts. 7. Installing the home set. This collection, as the titles show, is intended for the beginner. It contains very few diagrams, but many photographs, illustrating sets from the "Finger-ring" receiver to the largest cabinet sets.

Some of the points worthy of mention are the many portraits and brief biographies of prominent radio men, clear instructions on how to build practically every part for simple receiving sets and for the installation of home receiving sets, antenna, grounds, lightning arresters, etc. This set of books will be of considerable value to the beginner, but the lack of any index to the set would be rather a hindrance to the more advanced student of radio, who might wish to refer quickly to information on some special question.