



APPLICATION OF RELIABILITY AND LINEAR REGRESSION TO
ENTERPRISE ARCHITECTURE IN SUPPORT OF THE US AIR FORCE'S
CAPABILITY REVIEW AND RISK ASSESSMENT

THESIS

Peter Mastro
Capt, USAF

Richard Orcutt
Capt, USAF

AFIT/GSE/ENV/09-M05

DEPARTMENT OF THE AIR FORCE
AIR UNIVERSITY

AIR FORCE INSTITUTE OF TECHNOLOGY

Wright-Patterson Air Force Base, Ohio

APPROVED FOR PUBLIC RELEASE; DISTRIBUTION UNLIMITED

The views expressed in this thesis are those of the author and do not reflect the official policy or position of the United States Air Force, Department of Defense, or the United States Government.

AFIT/GSE/ENV/09-M05

APPLICATION OF RELIABILITY AND LINEAR REGRESSION TO ENTERPRISE
ARCHITECTURE IN SUPPORT OF THE US AIR FORCE'S CAPABILITY REVIEW
AND RISK ASSESSMENT

THESIS

Presented to the Faculty

Department of Engineering and Engineering Management

Graduate School of Engineering and Management

Air Force Institute of Technology

Air University

Air Education and Training Command

In Partial Fulfillment of the Requirements for the
Degree of Master of Science in Systems Engineering

Peter Mastro, Captain, USAF

Richard Orcutt, Captain, USAF

March 2009

APPROVED FOR PUBLIC RELEASE; DISTRIBUTION UNLIMITED

APPLICATION OF RELIABILITY AND LINEAR REGRESSION TO ENTERPRISE
ARCHITECTURE IN SUPPORT OF THE US AIR FORCE'S CAPABILITY REVIEW
AND RISK ASSESSMENT

Peter Mastro, Captain, USAF

Richard Orcutt, Captain, USAF

Approved:



David Jacques, PhD (Chairman)

13 MAR 09
date

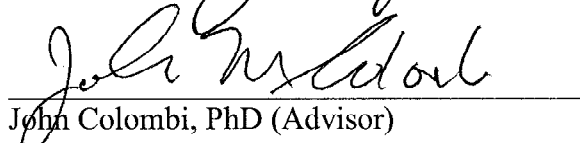

John Colombi, PhD (Advisor)

13 Mar 09
date

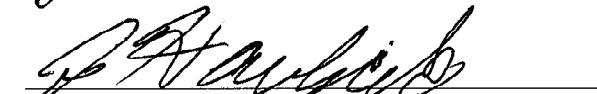

Major Jeffrey Havlicek, (Reader)

13 MAR 09
date

Abstract

This research explored the use of modeling and enterprise architecture in the analysis of Air Force Capabilities. The Air Force accomplishes this through the Capability Review and Risk Assessment (CRRA). The CRRA is currently performed by building architectures which contain Process Sequence Models (PSMs). PSMs are scored by Subject Matter Experts to determine the probability of successfully completing the mission they model and ultimately to determine the risk associated to Air Force capabilities. Two findings were identified. The first is that creating additional architectural viewpoints, some of which are currently being proposed for version 2.0 of the DoD Architecture Framework, can benefit CRRA development. The second is PSMs have fundamental limitations associated with the inability to capture dependencies among activities as well as the inability to get beyond binary success criteria to address issues of capability sufficiency. To remedy these limitations a model called Extended Sequence Models (ESMs) was developed. ESMs extend PSMs by using reliability modeling techniques combined with linear regression to show dependencies between components. This model also allows the effects of capability sufficiency to be captured and related to mission success.

AFIT/GSE/ENV/09-M05

Dedication

To our wives

Acknowledgments

We would like to acknowledge our research advisors, Dr. David Jacques and Dr. John Colombi. Their insight and direction were essential to the completion of this research project. It was their guidance and support throughout this effort that made this project meaningful. We would also like to acknowledge Major Jeffrey Havlicek for his dedication to this subject. This work benefited from his constructive feedback.

We are also appreciative to the staff at AF/A4, AF/A5, AF/A9, AFMC/A5C, Booz Allen Hamilton and our sponsor from SAF/XC, Ms. Deb Dewitt. Their candid feedback and willingness to devote their time to assist us ensured this research project was an insightful endeavor.

Special thanks to Lynn Curtis for all her help and administrative support which was crucial to putting all the pieces of the research together.

Last, we would like to say thank you to our wives. Without their support and understanding, this project would not have been possible.

Table of Contents

	Page
Abstract.....	iv
Dedication.....	v
Acknowledgments.....	vi
Table of Contents.....	vii
List of Figures.....	ix
1. Introduction.....	1
1.1 Research Questions.....	3
1.2 Implications.....	3
1.3 Thesis Overview.....	4
2. Background.....	5
2.1 Implementing JCIDS with the CRRA.....	8
2.2 CRRA Analysis using PSMs.....	10
2.3 Process Sequence Models.....	14
2.4 PSM Assumptions.....	22
2.5 Consequence Values.....	27
2.6 Architecture.....	31
2.7 Architecture Frameworks.....	32
2.8 Conclusion.....	38
3. Methodology.....	40
3.1 Overview.....	40
3.2 Summary.....	42
4. Analysis and Results.....	43
4.1 Introduction.....	43
4.2 Architecture Framework Analysis.....	43
4.3 Modeling capabilities using ESMs.....	52
4.4 ESM Assumptions.....	68
4.5 Verification of the Model.....	69
5. Conclusion.....	80
5.1 Overview.....	80
5.2 Recommendations for Future Research.....	84
Appendix A. Icon Taxonomy.....	86
Appendix B. MATLAB Code.....	87

Appendix C. Example Data Input.....	104
Appendix D. Acronyms	107
Bibliography	110

List of Figures

Figure	Page
Figure 2.1 Capability-Based approach (Jacques, 2006:4)	7
Figure 2.2 Example PSM, extracted from Agile Combat Support	12
Figure 2.3 PSM Excerpt.....	15
Figure 2.4 PSM Parallel Process.....	16
Figure 2.5 Example PSM Description	16
Figure 2.6 Triangular pdf of probabilities.....	17
Figure 2.7 PSM Computational Equivalentents	19
Figure 2.8 PSM Redundant Nodes.....	19
Figure 2.9 PSM Decision Node	20
Figure 2.10 Example Reliability Block Diagram	26
Figure 2.11 Consequence Value Ranges	28
Figure 2.12 COCOM Consequence Curve	30
Figure 2.13 DoDAF and MODAF Views.....	37
Figure 2.14 DoDAF Evolution	38
Figure 4.1 Capability Viewpoint (CV-1).....	47
Figure 4.2 ESM Implementation.....	52
Figure 4.3: Example of a Function Node.....	55
Figure 4.4 ESM Example.....	57
Figure 4.5 Most likely Probability value dependence on two controlling nodes.....	58
Figure 4.6 ESM Generic Example.....	66
Figure 4.7 Model Verification of a segment of ACS ESM.....	71

Figure 4.8 Required Surge Distribution.....	73
Figure 4.9 Ready Reserve Distribution.....	74
Figure 4.10 Retired Reserve Distribution	74
Figure 4.11 Percent of Surge Filled	75
Figure 4.12 Overall Probability of Success Distribution	78
Figure 4.13 Sensitivity Analysis Results	79

List of Tables

Table.....	Page
Table 2.1 Example of Consequence Description.....	29
Table 2.2 Consequence Scoring.....	30
Table 2.3 Zachman Framework.....	34
Table 4.1 Systems Measures Matrix (SV-7).....	50
Table 4.2 SME questions and responses.....	72
Table 4.3 SME dependency questions and responses.....	76

APPLICATION OF RELIABILITY AND LINEAR REGRESSION TO ENTERPRISE
ARCHITECTURE IN SUPPORT OF THE US AIR FORCE'S CAPABILITY REVIEW
AND RISK ASSESSMENT

1. Introduction

In 2003 the Department of Defense (DoD) changed the method it uses to define operational needs by transitioning from the Requirements Generation System to the Joint Capabilities Integration and Development System (JCIDS). This change was captured in the Chairman of the Joint Chief of Staff Instruction (CJCSI) 3170.01 series. The DoD Joint Staff described this change as one from a service-focused, threat-based analysis to one that is Joint-focused and Capability-based (JCS, 2005:6). Capability, as used in this research, is “the ability to achieve a desired effect under specified standards and conditions through combinations of means and ways to perform a set of tasks” as defined in the CJCSI 3170.01F (JCIDS). JCIDS is a key supporting process to the DoD Acquisition, Programming, and Budgeting processes. JCIDS includes three main analyses: identify the capabilities needed to perform required missions (Functional Area Analysis, or FAA), evaluate the current force’s ability to meet those capabilities (Functional Needs Analysis, or FNA), and identify possible solutions to eliminate any capability shortfalls (Functional Solutions Analysis, or FSA). In the language often used within the DoD, the purpose of this process is to “fill the capability gap” (CJCS, 2007:A5). The Air Force accomplishes these analyses for the capabilities it is expected

to deliver to the joint force with Called Capability Based Planning (CBP) as described in Air Force Instructions (AFI) 10-601 *Capability Based Requirement Development* and AFI 10-604 *Capability Based Planning*. Within this larger planning method, the Air Force uses a sub-process to identify its needed capabilities and determine its ability to deliver those capabilities, the first two analyses of the JCIDS process. The Air Force accomplishes this through a risk analysis method called the Capabilities Review and Risk Assessment (CRRA) (DAF, 2006: 6). Additionally, the analytic models used to accomplish the CRRA are Process Sequence Models (PSMs).

Years before the DoD made its transition to capability based planning, many in the federal government recognized a need to better document the architecture of the systems that were developed and used. In this use, architecture is “the structure of components, their relationships, and the principles and guidelines governing their design and evolution over time” (DoD, 2007: ES-1). This realization rose from the information technology community’s efforts to ensure system interoperability. Benefits of building system architectures were deemed important enough that statutory requirements were developed to mandate their construction in various situations. A few examples of these requirements are the Clinger-Cohen Act of 1996, Office of Management and Budget Circular A-130, the E-Government Act of 2002 (DoD, 2007: 3-2); and even JCIDS. Over the course of the last 15 years, there has been a growing appreciation for the benefits of documenting the architecture of various types of systems such as manufacturing systems, social systems, and political systems to name a few (Maier and Rechtin, 2002).

1.1 Research Questions

This research answers several questions. The first is, ‘How is architecture currently being used to support the CRRA?’ Included is an examination of PSMs to include their assumptions and limitations. The second question is, ‘How can the current architectural models be extended to make them more appropriate and useful?’ The third question is, ‘What other architectural models can be built and analyzed that would assist the CRRA?’

Since the CRRA is a sub-process of the larger CBP process the boundaries between the two can be somewhat ambiguous. This study considers the CRRA to encompass the activities needed to identify Air Force capability shortfalls, gaps, and trade space as described in AFI 10-604. For the purpose of this study it does not include the supporting processes of developing and writing Air Force Concept of Operations (CONOPS) which are covered in Air Force Policy Document (AFPD) 10-28, the development of the Master Capability Library (MCL) or Joint Capability Areas (JCAs), or the follow-on process of determining appropriate solutions to fill the capability gaps (DAF, 2005:5). A further discussion of the CRRA is presented in Chapter 2.

1.2 Implications

Developing architecture models to evaluate a complex system can lead to a better understanding of the system and its behavior. However, not all models are equally useful or even appropriate. This research aims to equip the CRRA practitioner with techniques to improve the CRRA methodology. Identifying ways the current modeling techniques can be extended while suggesting other architectural models not currently used will lead to a more complete picture of Air Force capability performance. It will result in a more

accurate analysis of current capabilities while at the same time making the method more defensible to those questioning its results. As the method improves, the Air Force will increase its ability to ensure it is equipped, organized, and trained to deliver the necessary capabilities to the Joint force.

1.3 Thesis Overview

With the research questions framed, the next chapter will provide a more detailed background of the CRRA, architecture, and the PSMs currently used to support the CRRA. Chapter 3 will explain the methodology that was used to answer the research questions. Chapter 4 will present and explain the results of the study. Finally, the conclusions and recommendations will be presented along with areas for further research in Chapter 5.

2. Background

In the 2001 Quadrennial Defense Review, a new strategy was presented to determine requirements for future military systems or organizational changes using a Capabilities-Based Assessment (CBA) approach (DoD, 2001:17). Shortly thereafter, Secretary of Defense Donald Rumsfeld, who himself had grown dissatisfied with the DoD's Requirements Generation System, sent the below memo to General Peter Pace, who was dual-hatted as Vice Chairman of the Joint Chiefs of Staff and Chairman of the Joint Requirements Oversight Council (JROC) (JCS, 2006:5).

March 18, 2002 7:17 AM

TO: Gen. Pace
CC: Paul Wolfowitz
Gen. Myers
Steve Cambone
FROM: Donald Rumsfeld
SUBJECT: Requirements System

As Chairman of the JROC, please think through what we all need to do, individually or collectively, to get the requirements system fixed.

It is pretty clear it is broken, and it is so powerful and inexorable that it invariably continues to require things that ought not to be required, and does not require things that need to be required.

Please screw your head into that, and let's have four or five of us meet and talk about it.

Thanks.

This memo led to an extensive redesign of the methods the DoD uses to determine future capabilities. In fact, it was decided the word 'requirements' would not even be used, in favor of the word 'capability'. It was out of this work that the Joint Capabilities Integration and Development System (JCIDS) was born and began implementation by the following summer of 2003 (JCS, 2006:5). The JCIDS process was created to support the

JROC requirement to validate and prioritize joint warfighting requirements (CJCS, 2007:2). By implementing a Capability-Based approach the JCIDS process has integrated joint concepts and integrated architecture into the Doctrine, Organization, Training, Material, Leadership and Education, Personnel, and Facilities (DOTMLPF) analysis methodology (CJCS, 2007:A-1). It attempts to achieve this by leveraging the experience of many agencies to identify improvements to existing capabilities as well as introduce new capabilities.

Another reason for the development of a Capabilities-Based approach was the acknowledgement that the United States could no longer know what nation, group of nations or non-state actor would pose a threat to the United States, its interests or allies. From this point forward, the United States was forced to try to anticipate adversarial capabilities and prepare an adequate response to those threats. In contrast to a Requirements Generation System, a Capabilities-Based model focuses on how a range of adversaries might fight while looking at various contingency locations as opposed to one static threat. It relies on determining what capabilities the armed forces need, to either deter or defeat its adversaries (DoD, 2001:IV).

The following simplified illustration displays the change in concept from the old Requirements Generation System to the revised Capability-Based approach (Figure 2.1). On the left side of the picture is the old “stove-piped” version, where services individually generated their system requirements from scenarios they envisioned as service-focused missions, rarely assuming any capability integration with the other services. It wasn’t until the end of the process that an attempt was made to integrate multi-force capabilities, taking a massive amount of effort from the joint community.

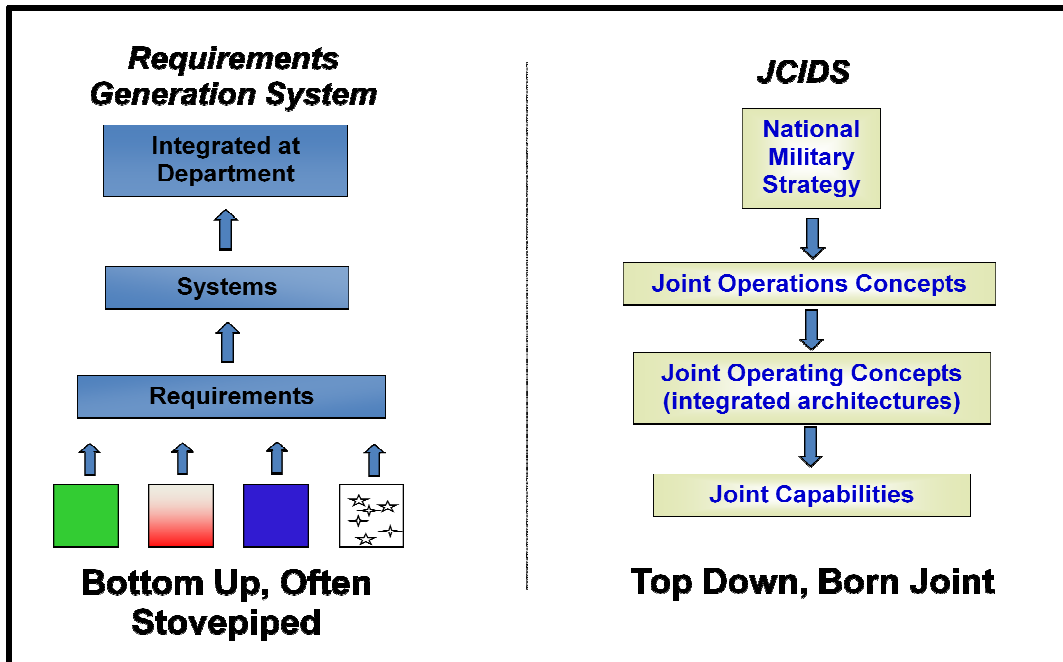

Figure 2.1 Capability-Based approach (Jacques, 2006:4)

This differs dramatically from the right side of the illustration where capabilities are conceptualized in a “born joint” top-down approach. Here, needed capabilities are identified from scenarios derived from missions based on joint operational concepts. From concept down through the analysis, the assumption is that all operations will be joint operations. In his paper, Bob Larsen commented that “The resulting warfighting capabilities have jointness built in; they start that way and they finish that way” (Larsen, 2004:7). During the analysis, capability needs are derived to determine what obligations must be fulfilled to complete the mission. This does not mean that the individual services no longer have to determine their own requirements; in contrast, “service participation is critical to developing joint perspectives throughout the process” (Larsen, 2004:7).

Capability Based Assessments are not unique to the military; many commercial businesses also take advantage of this concept. One instance of this, often pointed out as a success, is Wal-Mart Corporation. In a paper by Col Stephen Walker on Capabilities-

Based planning, the differences in methodology between Wal-Mart and K-Mart are discussed, ultimately leading to the conclusion that a Capabilities-Based approach is a factor (at least in part) to Wal-Mart's rise from an unknown entity in the late 1970s to a world marketing leader at the present time (Walker, 2005:5).

2.1 Implementing JCIDS with the CRRA

To implement JCIDS, the Air Force created their own Capabilities-Based Planning (CBP) process. The Air Force CBA is based on an existing Joint Operating Concept (JOC), Joint Integrating Concept (JIC) or Concept of Operations (CONOPS). Its purpose is to identify the capabilities required to execute missions, the shortfalls in existing weapon systems, and possible "trade space" where resources can be taken from areas where capabilities are comfortably being met and applied to areas with capability deficiencies. The CBA is scoped by six elements: Capabilities desired, Scenarios considered, Functions considered, Types of solutions considered, Resource limits, and Planning horizon (JCS, 2006:22). A sub-process to CBP is the Capability Review and Risk Assessment (CRRA). The CRRA was initiated by the Chief of Staff of the United States Air Force (CSAF) to facilitate the development of an operationally focused Capabilities analysis. During the 2002 Commander's Conference, the CSAF outlined his sight picture:

The bottom-line goal for the CRRA is to give senior USAF leadership an operational, capabilities-based focus for acquisition program decision-making....To accomplish this requires reviewing acquisition programs and discussing disconnects and prioritization in relation to how the programs support CONOPS capabilities. The focus shifts from program review to a review of how our programs contribute to the warfighting capability. The CRRA will seek to evaluate the health and risk of required CONOPS capabilities over the next 20 years. (HQ USAF, 2007:2)

Originally developed in 2003, and published biennially thereafter, the CRRA's purpose is to analyze the capabilities within each of the seven Air Force CONOPS which are:

- Global Strike
- Homeland Security
- Global Mobility
- Global Persistent Attack
- Nuclear Response
- Space & C4ISR
- Agile Combat Support

The CRRA has become more robust with each iteration. It is used to analyze capabilities against specifically developed joint scenarios, thus assuring current and future capabilities requirements and shortfalls are addressed with respect to scenarios of interest to the joint force. The CRRA is accomplished with respect to three timeframes to evaluate current capability performance as well as expected future capability performance (HQ USAF, 2008a: 24). The CONOPS Champions at Headquarters Air Force's office for Capability Based Planning, Operational Planning, Policy and Strategy (AF/A5X-C), ensure the results from these analyses are represented in the Air Force Planning, Programming, Budgeting, and Execution (PPBE), Strategic Planning, and Joint Capabilities Integration and Development System (JCIDS) process from the operational risk perspective (FAT, 2008).

In preparation for the CRRA, many Air Force and Joint strategic guidance documents are reviewed, including the Joint concepts, Combatant Commander (COCOM) Integrated Priority Lists (IPL), the Air Force Master Capabilities Library (MCL), Joint Capability Areas (JCA), lessons learned from recent military operations

(both wartime and contingency) and the shortfalls from the previous CRRA. From this detailed review, broad lists of mission areas are identified; AF/A5X-C focuses on the mission areas where success is deemed most crucial. During the CRRA analysis, two essential questions are addressed: “1) what is the Air Force’s overall probability of success in accomplishing each task, and 2) what is the consequence to the warfighting COCOM due to a particular mission’s probability of success?” Together the answers to these questions determine the risk related to the capability. (FAT, 2008)

2.2 CRRA Analysis using PSMs

The CRRA is intended to be an analytically supported assessment approach that provides the flexibility and adaptability required to meet the ever changing requirements of the Air Force. It was developed to be compatible with the Air Force Modeling and Simulation efforts, and to be relevant across the entire range of joint operations (HQ USAF, 2007:6).

Beginning with the 2007 CRRA, a method called Process Sequence Modeling (PSM) was developed and employed to help determine the most efficient and effective use of limited Air Force resources. It did this by identifying where the greatest shortfalls and highest consequences were located within the outlined scenarios (Bonafede, 2006).

PSMs are the primary analytical tool for the CRRA analysis and the continuing Capabilities-Based Assessment Methodology (CBAM). PSMs are architecture-based activity models, consisting of a series of activities or tasks, each represented in the model as a “node” (Bonafede, 2006:1). The degree that PSMs are based on larger enterprise architectures varies between the CONOPS. Within the Agile Combat Support CONOPS, an enterprise architecture based on DoDAF version 1.5 has been created. This

architecture currently contains an All Views (AV)-1, AV-2, Operational View (OV)-1, OV-2, OV-5, and OV-6c with future releases of other various views planned (ACS Architecture team, 2008:11-12). The two views that have supported the development of PSMs most directly are the OV-5 Node Tree and the OV-6c Operational Event/Trace Description. It is from the operational activities listed in the OV-5 and their arrangement in sequences in the OV-6c that PSMs are developed (Janus, 2008). In addition to using the OV-5 and sequencing information, it has been shown the production of an OV-2 Operational Node Connectivity Description can provide a means to graphically show the information exchange requirements within the CONOPS. This can provide information about the interconnectivity and interdependence of the capabilities and operations under examination (Eller, 2008: 26). Eller et al. also developed an OV-5 to PSM traceability matrix to verify PSM construction and completeness. Developing enterprise architecture as the basis for PSMs ensures they are traceable to strategic guidance, allows for reuse from one CRRA to the next, and ensures a more thorough examination of the capability.

The ability to accomplish the activities in a PSM for the purpose of achieving a specific effect demonstrates an Air Force capability. Therefore, each PSM models an Air Force capability. Each activity is a step, and each step is required to successfully complete in order to demonstrate a specified capability. Additionally, the ability to accomplish each of the tasks and activities in the PSM represents sub-capabilities that enable the overall PSM capability. In the 2007 CRRA, these nodes were linked to capabilities within the Master Capability Library. This changed for the 2009 CRRA PSMs, where most PSMs link nodes to the Joint Capability Areas (JCAs). An example of a PSM is presented in Figure 2.2. The goal of PSMs is to bring responsive, repeatable

and defensible analytical results to a previously haphazard and inefficient capabilities analysis (HQ USAF, 2006).

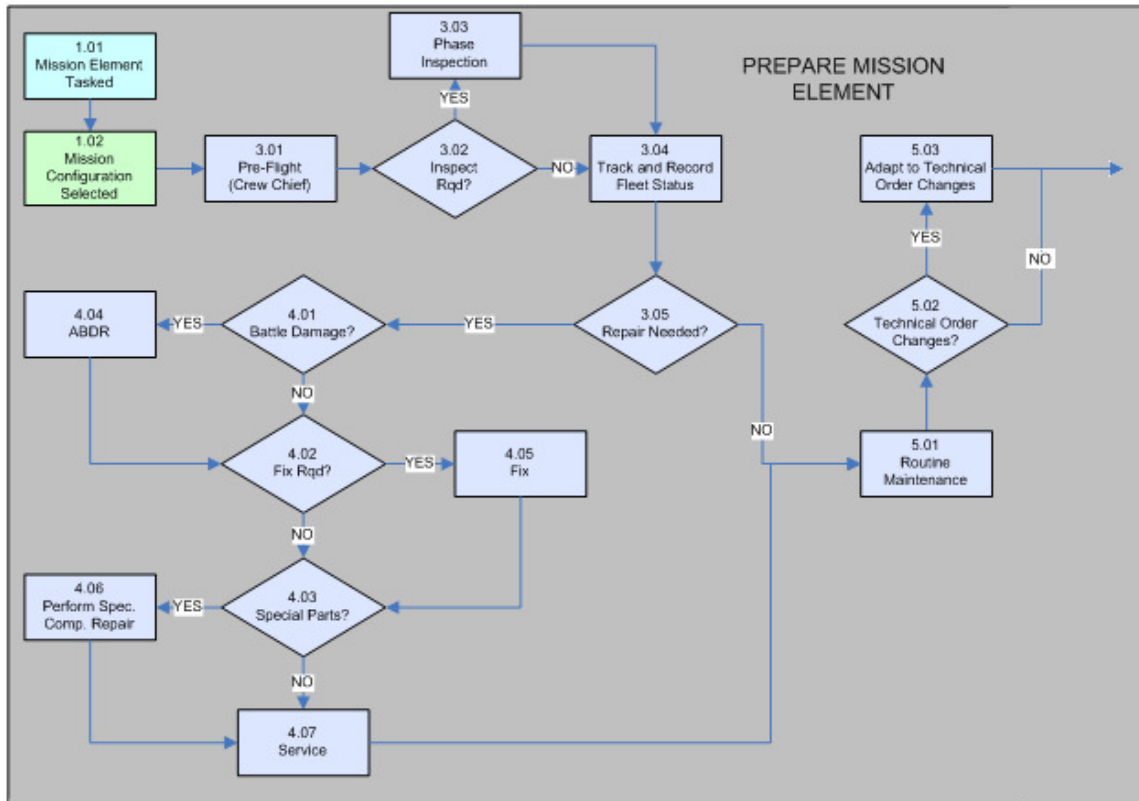

Figure 2.2 Example PSM, extracted from Agile Combat Support

PSMs are similar to Functional Flow Block Diagrams (FFBDs), long used in systems engineering, although there are symbolic, semantic, and syntax differences. A thorough explanation of functional analysis and FFBDs is provided in Appendix A of *Systems Engineering and Analysis* by Blanchard and Fabrycky (Blanchard, 2006:716). Within the Unified Modeling Language (UML) PSMs are similar to Activity Diagrams. Examples of Activity Diagrams can be found in *Applying UML and Patterns* by Craig Larman (Larman, 2002:607). Each node in a PSM is assigned Probability of Success (P(S)) scores by Subject Matter Experts (SMEs) from Air Staff, MAJCOMs, Combatant

Commander (COCOM), direct reporting agencies, and other services in conjunction with AF/A5X-C. SMEs must have operational experience as well as an in-depth understanding of training and procedures (HQ USAF, 2008a:22). One CRRA practitioner described the knowledge and experience required by the SMEs by stating “we don’t need Subject Matter PARTICPANTS, we need Subject Matter EXPERTS, the “E” is what is important” (FAT, 2008). Whenever possible, SME P(S) are backed up by supporting documentation, modeling & simulation, lessons learned and previous experience (FAT, 2008). After a PSM node is scored, the overall probability of success for the PSM is found along with the impact each node has on the overall PSM (HQ USAF, 2008a:26-32). A more thorough explanation of how the probability of success is determined is presented in the following section. While the overall probability of completion is important to understand, the more meaningful result of the PSMs is to determine the specific areas or tasks that are potential risk drivers for the completion of the selected mission. To uncover these tasks sensitivity analyses are accomplished on the PSM (HQ USAF, 2007:17). SMEs also determine which of the DOTMLPF fundamentals influence the successful completion of the node to help determine the root cause of the problem as well as assist with the later step of determining a solution to close the capability gap, if one exists (HQ USAF, 2008a: 22-23).

Another important concept developed for the CRRA is the determination of Potential Areas to Accept Risk (PAAR). PAARs are mission areas that are performing better than required and therefore offer an opportunity to shift resources from PAARs to areas with deficiencies. Upon discovery of a PAAR, primary assessments are done to determine subsequent order effects from accepting additional risk. PAARs are not

considered solutions, but suggested areas of additional research where “trade space” might be available if needed. Where PAARs are identified, it is recommended that further analysis be done prior to accepting any risk (FAT, 2008).

PSMs were first developed to support the CRRA (Bonafede, 2006). However, they have been successfully used to assess risk for other purposes. For example, while the CRRA’s purpose is to evaluate current and future capability performance PSMs can also be used to demonstrate the risk associated with various future force constructs. Used in this way, they can assist with selecting the appropriate types and quantities of systems to fill the capability gaps identified by the CRRA (Eller, 2008).

2.3 Process Sequence Models

This research studied the methods used to develop and analyze PSMs. The assumptions made through the construction and evaluation of PSMs are addressed, and the applicability of those assumptions is questioned. Based on the mission they are trying to model, conclusions are made as to the strengths and weaknesses of the current approach.

A PSM is a basic flow block diagram of the tasks or steps, which need to be completed to successfully accomplish the overall mission. An excerpt of a simple PSM is presented in Figure 2.3 (HQ USAF, 2008a: 18).

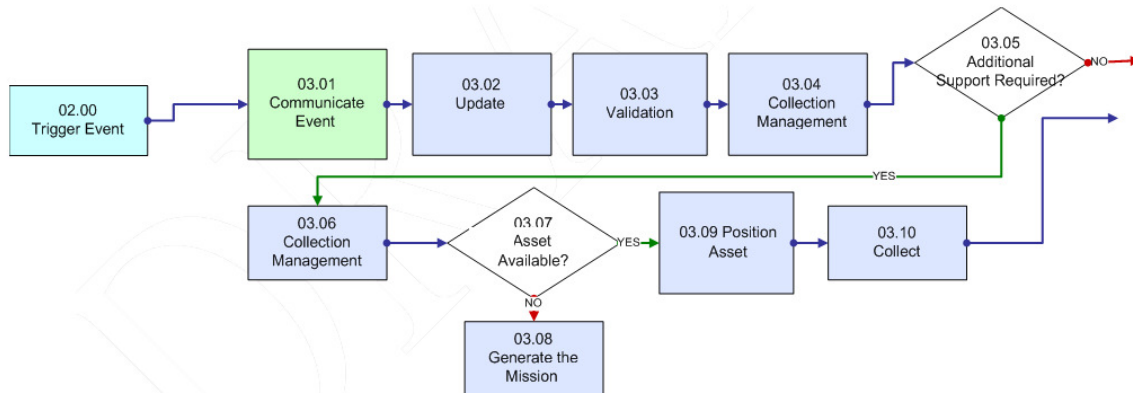

Figure 2.3 PSM Excerpt

The mission tasks are represented as rectangles while the arrows between the rectangles show the sequenced flow of the process (Bonafede, 2006:3). The arrow also communicates that the task at the head of the arrow cannot start until the task at the tail of the arrow is complete. Diamond nodes included in the PSMs are decision nodes. These nodes direct the flow through the model based on whether the condition in the decision node is satisfied. Another important feature of a PSM is a parallel process that allows steps within the parallel process to occur at the same time. The start of any one node does not require the completion of any of the other nodes in the parallel process. However, the process cannot move beyond the parallel process until all nodes are complete. An example of a PSM parallel process is presented in Figure 2.4 (HQ USAF, 2008a: 17-20).

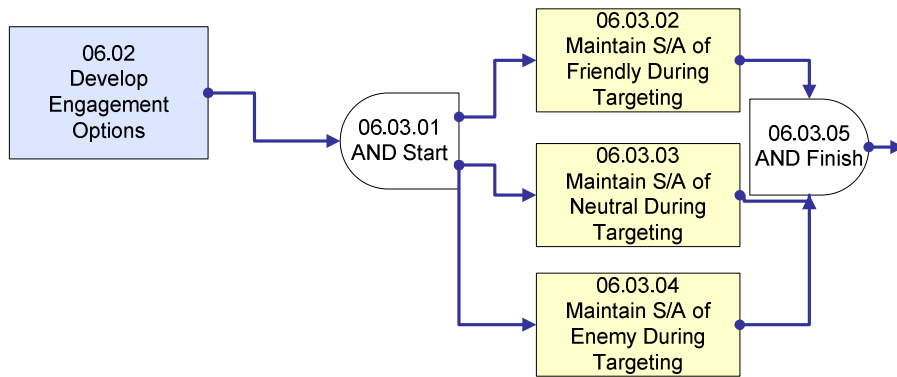

Figure 2.4 PSM Parallel Process

To analyze these models each node is “scored” by a team of SMEs. The score is the probability the node will be successful to the level that it will allow success for the entire PSM (HQ USAF, 2006: 13). The SMEs are presented a scenario and a description of the node they are to score. Included in the description are assumptions that can be made and factors to consider while determining the probability of success. An example of the description the SMEs are provided to assist them with scoring is presented in Figure 2.5. This description is from a node in the Agile Combat Support PSM that examines the Air Force’s ability to identify the surge in personnel (AF/A4LX, 2008:11).

3.01. Identify Surge Requirements: Scored. The probability of success of accurately assessing and quantifying need for increased manpower during an increase in operation tempo (rate of effort) to meet required mission dates well enough and within the timeframe needed to be able to successfully complete this PSM, in as much as it depends on this node. Includes capability to differentiate and prioritize between AD/ARC/civilian/contractor personnel. (MCL 5.6.4.1)

Figure 2.5 Example PSM Description

Studying the description shown in Figure 2.5 leads to some questions about how the SMEs determine the score they provide. Mainly, the score is described as “the probability of success of *accurately* assessing and quantifying...”. This leads to the

question ‘what accuracy is required?’ Currently, the answer to that question is, ‘The accuracy that allows for the successful completion of the PSM’ and is left up to the SMEs to decide. Therefore, SMEs are answering two questions. The first is ‘what accuracy is required for success?’ while the second is ‘what is the probability of reaching that level?’ If two different SMEs determine success differently, the probability of reaching that success is likely to be different as well. Additionally, this leads to the question of how succeeding at different levels of success effects the outcome of a PSM. These issues are addressed in Chapter 4.

For the purpose of focusing on only one node at a time, SMEs are told to score the node as if all previous nodes were successful (HQ USAF, 2008a:40). Because of this, the probability of success SMEs assign to the node is actually a conditional probability. The score is the probability of success *given* the previous nodes were all successful.

The SMEs actually input three probabilities to each node. The minimum expected score (worst day), the most likely score, and the maximum expected score (best day). This creates a triangular probability density function (pdf) where the independent variable is probability of success as shown in Figure 2.6 (Bonafede, 2006:7).

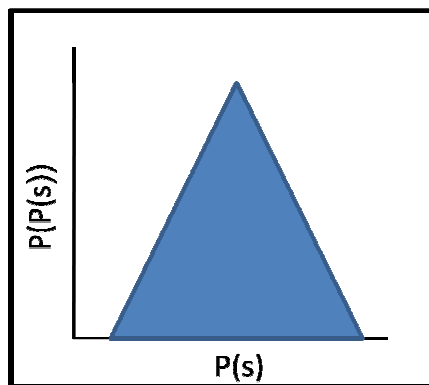

Figure 2.6 Triangular pdf of probabilities

Each of the decision nodes is provided a percentage. The percentage represents the expected portion of occurrences that will meet the condition in the decision node. The decision node does not adjust or get affected by any events that precede it. It has no knowledge of events that occurred before it and simply serves to provide a weighting to the nodes that come after it based on the percentage of occurrence of each path. In this way they are similar to an *uncertain event*, sometimes called a *chance node*, in decision trees (Holloway, 1979:32). Once the nodes are populated, a Monte Carlo analysis is performed on the PSM. A Monte Carlo analysis selects a probability for each of the nodes based on the triangular distribution entered. It then analyzes the model to determine an overall probability of success for the entire PSM (Bonafede, 2006: 4). The simulation is then run again, this time with different selected values for each of the nodes. This simulation is run approximately 2,000 times to find the most likely overall PSM probability of success values (FAT, 2008).

The computations required to find the overall PSM probability of success depends on the configuration of the model. In the PSMs currently used for the CRRA, every node needs to complete successfully for the PSM to complete successfully. Therefore, the method used to calculate the total probability of success is simply the product of all of the probabilities that were assigned to each node. Additionally, even if tasks are accomplished in parallel with each other, the process still requires each to be accomplished; therefore the calculation for the total probability remains the same. As an example, the overall probability of success for the two processes in Figure 2.7 is identical and is calculated by (HQ USAF, 2007: 22):

$$P(S)_{Total} = P_A(S)P_B(S)P_C(S) \quad (1)$$

where $P(S)_A$, $P(S)_B$, $P(S)_C$ are the probabilities assigned to each node (Ebeling, 1997: 84).

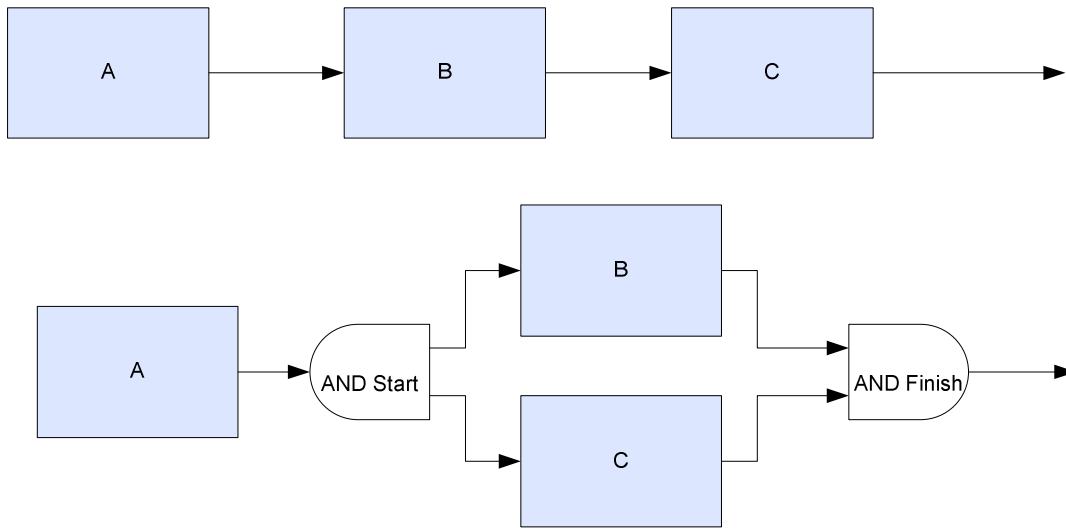

Figure 2.7 PSM Computational Equivalents

Although it isn't seen on any current PSM reviewed for this research, there is nothing to preclude a model from having redundant tasks (Bonafede, 2009). A redundant task doesn't necessarily need to be accomplished for the successful completion of the process. Since every task does not need to be completed, the algebra describing the total probability of success changes to equation 2. An example of redundant task PSM is presented in Figure 2.8.

$$P(S)_{Total} = P_A(S)[P_B(S) + P_C(S) - P_B(S)P_C(S)] \quad (2)$$

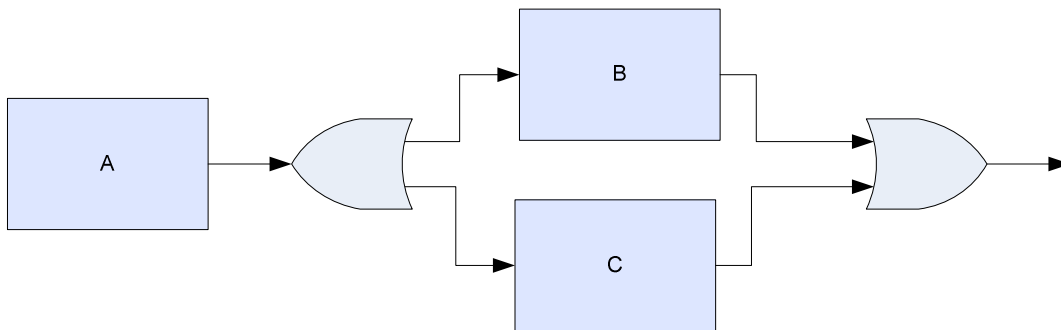

Figure 2.8 PSM Redundant Nodes

For situations where more than two nodes are redundant the total probability can be represented with the expression (Ebeling, 1997: 86):

$$P(S)_{Total} = (1 - \prod_{i=1}^n (1 - P(S)_i)) \quad (3)$$

To calculate PSMs with decision nodes, the equation has to account for the change in analyzed nodes depending on the path the process follows. For example, given the process model in Figure 2.9., if 60% of the occurrences result in a YES decision while 40% of the occurrences result in a NO decision, then the closed form equation for the PSM would be (FAT, 2008):

$$P(S)_{Total} = P_A(S)[(.6)P_B(S)P_C(S) + (.4)P_D(S)P_E(S)] \quad (4)$$

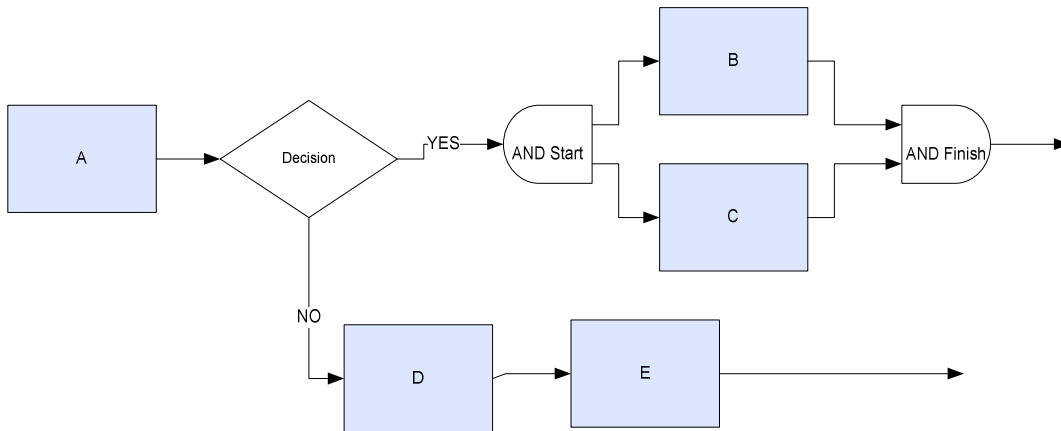

Figure 2.9 PSM Decision Node

The equations for the overall probability of success for the PSM presented here assume the individual steps or activities are independent from each other (Ebeling, 1997: 84). This is an important assumption of PSMs that will be addressed in Chapter 4.

As mentioned above, in addition to the calculation of the total probability of success, a sensitivity analysis is conducted to determine the node that has the highest impact on the overall probability and ultimately the consequence. Two different

sensitivity analyses are conducted, availability and incremental. Originally the incremental technique was referred to as the marginal sensitivity measure (Bonafede, 2006: 6). For the availability method the probability of success for the node being examined is changed by half of the difference between the most-likely probability and a probability of 1.0 while all other nodes remain at their most likely value. For example, if the node was scored with a 0.8, the node probability would be changed to 0.9 whereas if the node was scored 0.9 the score would be changed to 0.95. Once the score, or probability of success, is changed for one node the total PSM probability is found and related to operational consequence. That node is then returned to its original value, the next node in the process is changed and the total probability is again calculated. The node that has the largest impact on the probability of success, and thus the consequence score, will be listed as the main driver. A list of nodes could then be generated in order of decreasing impact on the PSM probability of success. Two factors determine how much impact any particular node will have. The first is the node's orientation in the PSM. If the node is accomplished every time the PSM is evaluated it will have more impact than a node positioned after a decision node that is accomplished only 20% of the time. The second factor is the value of the node's original most likely score. All other factors being equal, a node originally scored 0.2 is going to be a larger driver than a node scored 0.8. This is because during the sensitivity analysis the node that is 0.2 will triple its value to 0.6 whereas the node scored 0.8 will only change to 0.9. This method was decided upon by the CRRA practitioners to highlight the nodes that have a lower probability of success (FAT, 2008).

To accomplish the incremental sensitivity analysis the first partial derivative of the closed form PSM equation is computed with respect to each node. The node that results in the greatest partial derivative will be the highest risk driver. Again, a list can be computed to order the tasks (or nodes) in decreasing order of sensitivity. It should be noted that this method also places greater weight on the nodes that have the lowest probability of success. To see why this is, examine a PSM with three nodes-- A, B, C. The total probability is $P(S)_{Total} = P(S)_A P(S)_B P(S)_C$. The partial derivatives with respect to each node are:

$$\frac{\partial P_{total}}{\partial P(S)_A} = (P(S)_B)(P(S)_C) \quad \frac{\partial P_{total}}{\partial P(S)_B} = (P(S)_A)(P(S)_C) \quad \frac{\partial P_{total}}{\partial P(S)_C} = (P(S)_A)(P(S)_B)$$

If $P_A = 0.8$, $P_B = 0.2$ and $P_C = 0.7$ then the total value of the first derivatives would be:

$$\frac{\partial P_{total}}{\partial P(S)_A} = .14, \quad \frac{\partial P_{total}}{\partial P(S)_B} = .56, \quad \frac{\partial P_{total}}{\partial P(S)_C} = .16$$

Node B would be listed as the driver because it has the highest partial derivative. It had the highest partial derivative because it had the lowest probability of success (FAT, 2008).

2.4 PSM Assumptions

Constructing models of a process and calculating the probability of success using this method makes certain assumptions about the system or process it is modeling. These assumptions are appropriate if the real-world system meets certain criteria. These criteria are:

- Each activity or task represented by the nodes has only two relevant states; either success or failure. Another way to describe this is the task is a boolean event whose possible states are mutually exclusive.

- If an activity does have degrees of success, the degree by which it succeeds does not impact the chance of success for the entire PSM or for any other node, thus the degrees of success are not relevant.
- The success of each activity can only be dependent on whether the activities that occur before it were successful and are independent in all other ways. The score the SME's give each node is the probability of success *given* the previous nodes were all successful. The fact that nodes can only be dependent on the nodes that occur before them implies they cannot be dependent on nodes that occur in parallel with them. For the bottom process in Figure 2.7 node B could not depend on node C or vice versa. Additionally, the score for one activity will not affect the score on another activity; therefore the scores are independent from each other.
- The node represents an activity or task that is a discrete event that has a beginning and end. Without a specific end the process could not continue to the next node.
- The nodes, which are discrete events, represent a task or activity in the appropriate timeframe relative to other tasks or activities. For example, a three node PSM consisting of a node representing the recruiting of new personnel, a node representing the training of the personnel, and a node representing the personnel performing aircraft maintenance activities is to be evaluated. If the question to answer is 'what is the probability the airplane can be adequately maintained during a 30-day period of high tempo?', the probability of success entered for the recruitment of new personnel shouldn't be the probability to recruit during this period of high tempo because those recruits are not the ones

performing the maintenance. The recruits performing the maintenance are those who joined the workforce some time in the past. Therefore, to answer the question of ability to maintain airplanes during the 30-day window, the probability that recruitment was done successfully in the past would have to be evaluated.

When examining the situations that are currently modeled with PSMs to determine if they meet the above criteria, what should be remembered is that all models are wrong; some are useful (Kurkowski, 2007). Any model needs to find the correct balance between being complex enough to represent reality, while remaining simple enough to construct and analyze. A simpler model is more practical to build, but might not be as realistic. In other words, an attempt to make the model "correct" could make the model less useful to practitioners. However, committing the error in the other direction can be even more dangerous. Making assumptions about the modeled system for the purpose of simplifying the model can result in a model that has no bearing on reality if those assumptions are not valid. The model could reveal supposed insights that do not correlate to reality and force decisions to be made that only later prove to be poor. Constructing models that either require too much information or ones that are too simplistic will result in wasted resources, frustration among users, and can lead to a situation where the Air Force is not able to provide a capability when called upon. With those warnings in mind, an evaluation of the current use of PSMs is presented.

While reviewing the PSMs used for the 2007 CRRA, as well as a sample of PSMs for the 2009 CRRA, some questions concerning the assumptions were noted. For

example, assuming each node can be modeled as having only two states, success or failure, significantly constrains the information that can be learned from the analysis and might not be appropriate. While this assumption seems appropriate for some nodes, other nodes seem to be better served if they are allowed to undertake other various states. Nodes that appear to meet these assumptions well are those that represent activities that are clearly discrete actions in time and either result, or do not result, in an outcome. An example of this is a node that represents the task *Deploy Weapon*. It is reasonable to assume the only cases that matter, or need to be examined, are if the weapon deploys or doesn't deploy, while any case in between can be correctly placed in the category of not deploying successfully. However, there are other activities, many of them residing within combat support, for which the degree a task is accomplished is important. Examples of nodes that seem to fall squarely into this category are ones dealing with training or the assignment of personnel to a particular task, where quantities are important. There are many other areas this applies to as well. This also touches on a desire heard from CRRA practitioners to not only model the Air Force's ability to deliver a particular capability but to capture what level of quality or sufficiency that capability can be delivered (FAT, 2008). A model that allows certain activities of interest to take on an independent variable other than probability of success, and to allow that variable to have multiple levels, would be beneficial to the CRRA process.

The hypothesis that the degree to which a task is accomplished matters to the outcome of the PSM implies that the degree somehow affects the results of other nodes, and consequently the whole PSM. This challenges another assumption already listed, that each node's score is independent from other nodes' scores. This also relates to the

desire heard during the course of the research, especially among the Agile Combat Support community, to show how the accomplishment of their tasks directly contributes to the outcome of Operational CONOPs PSMs (FAT, 2008). To accomplish this, a model which allows individual tasks or activities to map to and influence the likelihood of accomplishing other individual tasks, some of which reside across many different PSMs, or CONOPs, would be beneficial.

The assumption that each node is a discrete event that must end prior to the next one beginning requires a more nuanced examination to determine its validity, or even if the assumption is actually being made in the current technique. This resides in the apparent confusion over whether or not these models are in fact models of processes, as their name would suggest, or whether they are more akin to reliability block diagrams. If it is a true process model then the order of the nodes **does** matter and ensuring the nodes represent activities that have a completion is important to moving to the next activity in the process. However, if these are reliability block diagrams, it is valid to have a series of activities all occurring at the same time that will only complete at the end of the examination period. A simple reliability block diagram is presented in Figure 2.10 for an example of the reliability a tire will stay on a car (Blanchard and Fabrycky, 2006:379-380). One “activity” or possibly more appropriate “success condition” is that the lug nuts will stay on, another is that the tire stays on the rim. These both need to continuously happen at the same time for the success of the tire staying on the car.



Figure 2.10 Example Reliability Block Diagram

These two success conditions are not discrete activities. They are conditions that must be maintained simultaneously during the entire period of examination.

There are tasks within PSMs that would suggest the model is meant to be a reliability block diagram; however, if that were the case there would be no need to include AND paths that attempt to show mandatory tasks that occur at the same time while others do not. Additionally, there does not appear to be a consensus among CRRA practitioners as to the answer of this question. The reason there is not a consensus is this does not matter if you maintain the assumptions listed above, mainly that the tasks are independent from each other. The mathematical model to represent total probability of success for the PSM is the same either way. As described in the sections above, it would be the multiplication of the probability of success for each of the nodes. However, when relaxing the assumption of independence it becomes necessary to understand which nodes represent activities performed in a process and which nodes represent activities that are ongoing aspects of the environment within which the process is being run. The timing of activities also need to be considered when dependence is added to the model to ensure that prior to the execution of a node, all nodes it is dependent upon have executed. This leads to the final caution that the nodes are both modeled and evaluated by SMEs in the appropriate time frame relative to each other.

2.5 Consequence Values

The second part of the CRRA process is determining the consequence associated with the output of the PSM. The PSM probability of success is linked to operational consequences through a methodology and excel spreadsheet tool developed at AF/A5X-C. To accomplish this, members of AF/A5X-C meet with the Combatant Commands to

determine how the performance of the PSMs affect their ability to complete operational missions.

The first step is to elicit from the COCOMs what are the *Good Enough Value* (GE) and the *Limited Military Value* (LMV) PSM probabilities (Bonafede, 2006: 2). GE is defined as “The probability of success for a particular mission, above which the warfighter has enough/excess capability to successfully complete mission objectives within acceptable levels of consequence”. The LMV is defined as “The probability of success for a particular mission, below which is negligible military value to the warfighter”. These regions are placed onto a graph as shown in Figure 2.11 (FAT, 2008).

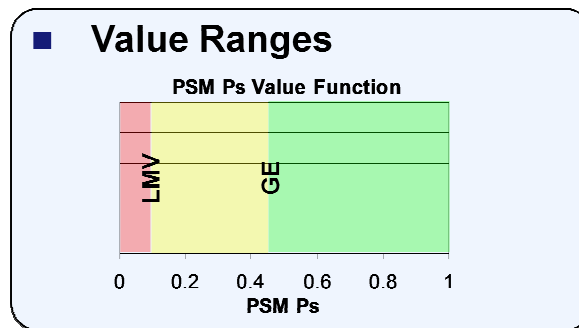

Figure 2.11 Consequence Value Ranges

Next, COCOMs select severity factors to consider for the particular mission being executed. Severity factors are areas of concern that should be considered to understand the full range of consequences. Examples of severity factors are friendly casualties, public security confidence, loss of friendly infrastructure, and adverse economic impact, to name a few (Bonafede, 2006: 5). AF/A5X-C has developed 16 severity factors, from which COCOMs select 2-5 they feel are most relevant to the mission under examination. Each severity factor is then divided into 6 consequence values pertaining to catastrophic, extensive, major, substantial, modest, and minor outcomes. Descriptions of each

consequence value are provided in a word picture to adequately provide examples of what would constitute that value. *The Loss of Friendly Infrastructure* description is shown in Table 2.1.

Table 2.1 Example of Consequence Description

Severity Factors >	Loss of Friendly Infrastructure
Catastrophic (6)	Friendly centers of gravity damaged or destroyed. Widespread damage/loss of critical infrastructure. Nationwide electrical power outages for indeterminate amount of time; nationwide water, food, and medicine supply shortages affect most citizens.
Extensive (5)	Large regional electrical power outages for indeterminate amount of time; nationwide water, food, and medicine supply shortages.
Major(4)	Friendly centers of gravity attacked. Local damage/ loss of critical infrastructure. Regional infrastructure affected. National transportation system damage (such as widespread airport shut downs) for indeterminate amount of time, large regional extende
Substantial (3)	Critical infrastructure sustains local damage. No regional damage or loss. Nat'l transportation system temporarily ceases, regional extended electrical power outages, nationwide Internet operation temporarily incapacitated, National/international banking
Modest (2)	Local/ limited damage to infrastructure. No regional damage or loss. National transportation system significantly slowed down, widespread Internet operation significantly slowed, National/international banking and/or monetary systems significantly slowed
Minor (1)	No loss of critical infrastructure. Nat'l transportation system has temporary slow downs or slow downs only limited to regional activity, Internet operation has regional slow downs, regional banking and/or monetary systems significantly slowed, regional s

Following the selection of the severity factors, the COCOMs determine what the worst case, most likely, and best case consequence values are for each of the three probability regions identified in the first step (below LMV, between LMV and GE, and above GE) as shown in Table 2.2.

Table 2.2. Consequence Scoring

Severity Factors	Score	Loss of Friendly Infrastructure								
Factor Weights		0.624								
Data Points		Low	Best Est.	High	Low	Best Est.	High	Low	Best Est.	High
Catastrophic	6									
Extensive	5			X						
Major	4		X				X			
Substantial	3					X				X
Modest	2	X			X				X	
Minor	1							X		
Manual Override										

From the information gathered and a relative weight to each of the severity factors selected, a graph is generated shown in Figure 2.12.

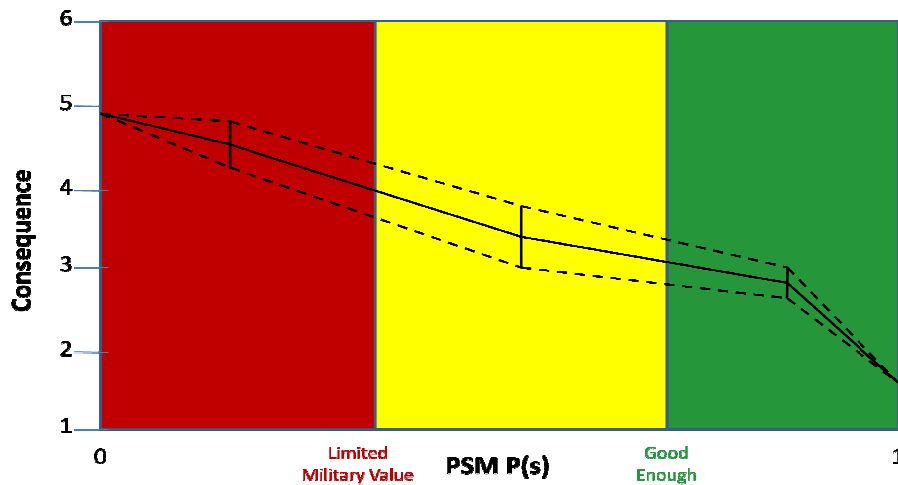

Figure 2.12 COCOM Consequence Curve

This graph relates the overall probability of success for a PSM, shown on the horizontal axis, to consequence values, shown on the vertical axis. For each run of the PSM a P(S) is generated that relates to a consequence value through the chart above. As stated earlier, this is run approximately 2,000 times to find the consequence of the PSM. Additionally, during the sensitivity analysis the node that creates the greatest change in consequence score is determined to be the driving node (HQ USAF, 2008b) (FAT, 2008).

This analysis completes the analytic portion of the CRRA evaluation process, evaluating both the capability gaps as well as the consequences to the warfighter if a capability gap goes unfilled.

The score calculated by the analytic method described above is only part of the assessment. There is also supplementary information elicited from the SMEs in the form of a rationale to justify the P(S) they assigned. During interviews with several SMEs and stakeholders it was purported that the rationale given was actually more important than the probability scores. The rationale, it was reasoned, was the basis of the capabilities' performance and any underlying gaps that could be associated with a probability of failure. However, during a SME scoring conference, there seemed to be significant confusion concerning what constituted node failure instead of a somewhat ambiguous idea of milder capability degradation. This question was pondered by many in attendance, but was not addressed in the conference, with hopes that future iterations of CRRA analysis could extend to a level where varied levels of success can be considered.

2.6 Architecture

While architecture in its classical form as the art and science of designing and erecting buildings has been a discipline for thousands of years, the idea of general systems architecture and enterprise architecture are much more recent (Architecture, 2000). As a tool, architecting becomes useful when trying to define, describe, and understand complex and unprecedented systems. As a system grows, the number of interrelationships grows at a much faster pace than the number of components; this requires tools and techniques to understand the various aspects of the system (Maier and

Rechtin, 2002:5). In a book on Service Oriented Architecture, the authors describe the evolution and need for architecture in this way:

“In the beginning, there were programs, and programs were good, and programs didn’t need no stinking architectures. And then there was business and the businesses grew, and the programs grew, and chaos was on the face of the business. And so, in an effort to create order, programmers adopted systematic structures to organize the programs and help the business. And any structure, be it a strip mall or the Taj Mahal, or even Noah’s Ark, has some underlying design, however haphazard, know as an architecture.” (Hurwitz, 2006)

Through this somewhat humorous explanation of why architecture is important, it becomes obvious that as projects become bigger, architecture can help maintain order, focus, and direction. This same phenomenon occurred during the creation of classical architecting. Thousands of years ago the Greeks and the Romans built cities, aqueducts, road systems, and defenses. The increasing complexity of the systems they created led to the formulation of new tools to understand them (Rechtin, 1991:xiii). The current practices in systems architecting have their root in the mid-1980’s (GAO, 2003:1). During this time there was another increase in the complexity of systems under design, this time in the form of information technology (Rechtin, 1991:xiv).

2.7 Architecture Frameworks

With the maturation of system architectures, various architectural frameworks have been developed. A framework is a standard by which architectures are described and is analogous to blueprint standards (Maier and Rechtin, 2002:221). Current frameworks can be traced to the late 1980s. It was at that time that John Zachman wrote an article published in IBM Systems Journal titled “A Framework for Information Systems Architecture”. This paper laid the foundation for what became known as the Zachman framework which, according to the federal government’s Chief Information

Officer's Council, "has received worldwide acceptance as an integrated framework for managing change in enterprises and the systems that support them" (CIO Council, 1999:19). In his seminal work, Zachman examined classical architecture to uncover a descriptive framework that could be used to describe information systems (Zachman, 1987). He described two architectural "observations" that became the basis for his framework and subsequent frameworks. The first is that the architecture has different representations. These were called "fundamental architectural representations" while contemporary frameworks have called these representations *views* or *viewpoints*. He explained there are three representations based on the perspective of the owner, designer, and builder of the system. An important distinction made by Zachman was that the three views are not merely descriptions of the system at varying levels of detail but are actually different in nature and content showing the same system from a different point of view. Level of detail is an independent variable and can exist at any desired level within each of the representations. The second observation was that within each representation there are different descriptions that answer the six interrogatives, who, what, where, why, when, and how. Even though each of these descriptions addresses the same system, they are independent from each other and provide different information about the system. The combination of the representations (or views) and descriptions into a matrix forms the foundation of the Zachman framework (Zachman, 1987:282). A more recent example of the Zachman Framework that incorporates more than three views is presented in Table 2.3.

Table 2.3. Zachman Framework (Ambler, 2004)

	What (Data)	How (Function)	Where (Locations)	Who (People)	When (Time)	Why (Motivation)
Scope {contextual} Planner	List of things important to the business	List of processes that the business performs	List of locations in which the business operates	List of organizations important to the business	List of events/cycles important to the business	List of business goals/strategies
Enterprise Model {conceptual} Business Owner	e.g. Semantic Model	e.g. Business Process Model	e.g. Business Logistics System	e.g. Workflow Model	e.g. Master Schedule	e.g. Business Plan
System Model {logical} Designer	e.g. Logical Data Model	e.g. Application Architecture	e.g. Distributed System Architecture	e.g. Human Interface Architecture	e.g. Process Structure	e.g. Business Rule Model
Technology Model {physical} Implementer	e.g. Physical Data Model	e.g. System Design	e.g. Technology Architecture	e.g. Presentation Architecture	e.g. Control Structure	e.g. Rule Design
Detailed Representation {out-of-context} Subcontractor	e.g. Data Definition	e.g. Program	e.g. Network Architecture	e.g. Security Architecture	e.g. Timing Definition	e.g. Rule Definition
Functioning System	e.g. Data	e.g. Function	e.g. Network	e.g. Organization	e.g. Schedule	e.g. Strategy

Several other frameworks have been developed since Zachman proposed his in 1987 to include frameworks by the Institute of Electrical and Electronics Engineers (IEEE), the International Standards Organization (ISO) and the DoD (Maier and Rechtin, 2002:222). The DoD released its first framework in 1996 in response to passage of the Information Technology Management Reform Act of 1996, later designated the Clinger-Cohen Act (CCA) of 1996 (DoD, 2007:3-2). The CCA mandates “An integrated DoD architecture with operational, system, and technical views shall be developed, maintained and applied...” (DoD CIO, 2006:168). As the original name of the act suggests, this applied to information technology management. In June 1996 the DoD released the Command, Control, Communication, Computer, Intelligence, Surveillance and

Reconnaissance (C4ISR) Architecture Framework version 1.0. That Framework was updated and released as C4ISR Architecture Framework version 2.0 in December of 1997. Two months later the DoD mandated the framework be used for all C4ISR architecture descriptions (DoD, 2007:ES-3). The framework continued to expand and in 2003 was renamed to the DoD Architecture Framework (DoDAF) to capture the intent to use this framework for not just IT systems but for all DoD systems to included enterprise architecting.

The Open Group Architecture Framework (TOGAF) defines architecture framework as:

“a tool which can be used for developing a broad range of different architectures. It should describe a method for designing an information system in terms of a set of building blocks, and for showing how the building blocks fit together. It should contain a set of tools and provide a common vocabulary. It should also include a list of recommended standards and compliant products that can be used to implement the building blocks.”
(TOGAF, 2008)

To that end, the research focused on three of what was understood to be the most relevant architectural frameworks for this project. The DoDAF Version 1.5, the Ministry of Defense Architectural Framework (MODAF) and the Draft DoDAF Version 2.0 were analyzed in detail. As previously mentioned, there are several other types of architecture frameworks available, however this research was focused toward these particular frameworks due to the intended audience.

DoDAF, which has been the standard DoD guidance since it was initially approved in 2003 as Version 1.0, later upgraded in 2007 to Version 1.5, describes 29 architectural models that provide guidance to consistently represent different aspects of a system depending on the information needed to be displayed.

The MODAF, used by the United Kingdom, adopted the DoDAF v 1.5 views. The All View (AV), Operational View (OV), Systems and Services View (SV), and the Technical Standards View (TV), were upgraded by adding Strategic Views (StVs), Service Oriented Views (SOVs), and Acquisition Views (AcVs).

In comparison, the Draft DoDAF v 2.0 that was reviewed for this research has a total of 49 different models to display the various representations. These are now called “Viewpoints” rather than “Views”. It incorporated, among other things, similar views to those found in the MODAF. For example, the Capability Viewpoint (CV) can be directly compared with MODAFs StV, where “The viewpoints within the CV are high-level and describe capabilities using terminology which is easily understood by decision makers and used for communicating a strategic vision regarding capability evolution” (DoD, 2008a:25). Similarly, the updated Services Viewpoint can be related to the MODAF SOV, which supports the operational and capability functions. Furthermore, the Project Viewpoint was developed using feedback from the Acquisition community and can be compared to the MODAF AcV. For ease of reference, the following pictorial representations have been provided so the reader may compare between the Draft DoDAF v 2.0 and the MODAF.

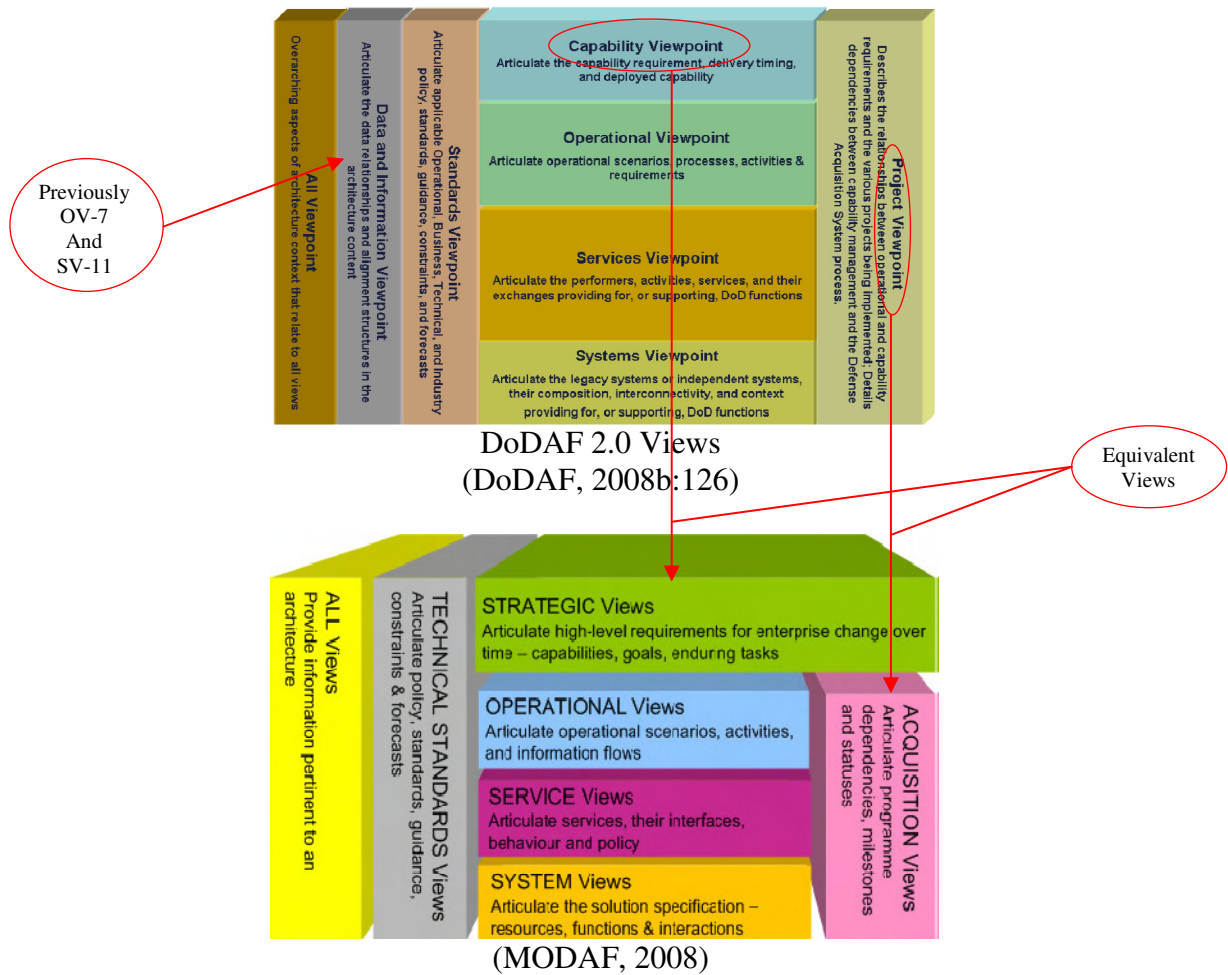
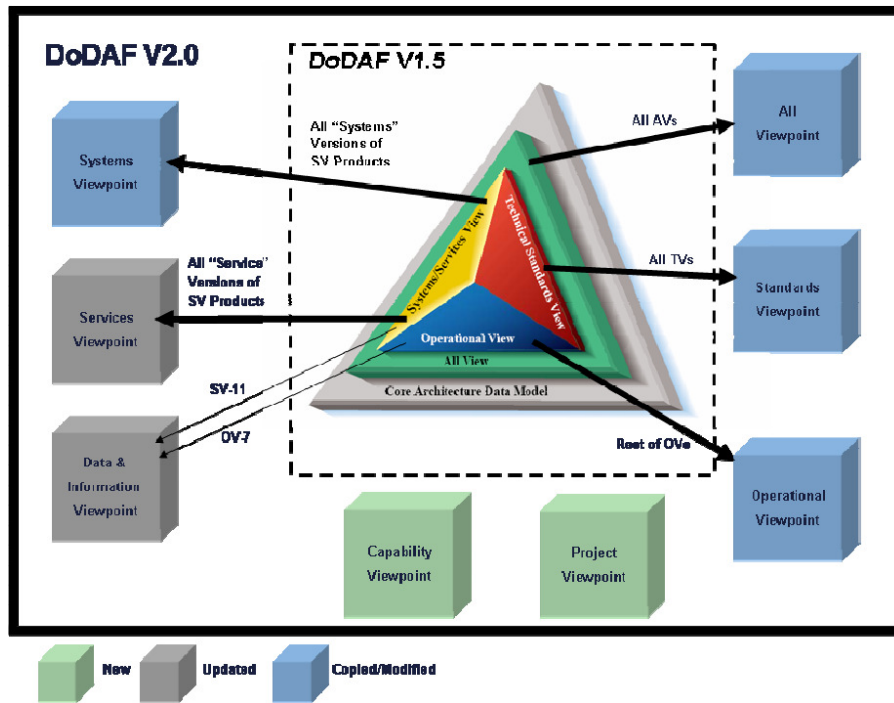

Figure 2.13 DoDAF and MODAF Views

Additional viewpoints were added or updated to enhance the capabilities of the DoDAF architecture. For example, in the DoDAF v 1.5, Services and Systems Views were linked together, whereas in the Draft DoDAF v 2.0 they are separated into distinct Viewpoints. Furthermore, a Data and Information Viewpoint was created using OV-7 and SV-11 views of DoDAF v 1.5. Figure 2.17 provides a pictorial overview of how the updated Draft DoDAF v 2.0 compares with the older DoDAF v 1.5.



DoDAF V1.5 Evolution to DoDAF V2.0
(DoDAF, 2008b:127)

Figure 2.14 DoDAF Evolution

Since the creation of the DoDAF in 2003 there has been effort to transition from a product-centric framework to one that is data-centric. For example, as opposed to focusing on the viewpoint and description of a particular architecture product, the emphasis would be on creating a common database of architectural information from which various products can be built. By changing the focus, the creation of architectures that share common data descriptions across several viewpoints becomes easier to construct, a result referred to as an integrated architecture. Additionally, models can be generated that don't necessarily fit into one of the viewpoints described within DoDAF.

2.8 Conclusion

This chapter provided background to the Air Force's Capability Based Assessment, specifically the CRRAs, introduced Process Sequence Models, and explained

how the probability of success is related to mission outcomes and consequences. This chapter also provided background to Enterprise and Systems Architecture and Architecture Frameworks. Additionally, changes to the DoDAF in the draft version 2.0 that were deemed important to this research were presented. An understanding of the basics of these topics greatly assists in understanding the analysis and suggestions presented in Chapter 4 and the conclusions presented in Chapter 5. Next, the methodology that was used to answer the research questions and develop research conclusions is presented in Chapter 3.

3. Methodology

3.1 Overview

To answer the first research question listed in Chapter 1, “How is architecture currently being used to support the CRRA?”, Process Sequence Models (PSMs) as they are currently performed have been explained along with the assumptions they make about the system they model. It was found PSM assumptions force limitations on the model that would be beneficial to remove. Additionally, those assumptions might not even be appropriate for some situations currently modeled by PSMs. This chapter introduces a methodology to relax those assumptions. Following this chapter, Chapter 4 provides more details on the new methodology and demonstrates its application.

When answering the second research question, “How can the current architectural models be extended to make them more appropriate and useful?”, it was an aim of this research to keep any proposed architectural models based on the current techniques of PSMs. This is to prevent the CRRA practitioners from having to start from scratch if they choose to adopt the conclusions of this research. Consequentially, it allows the CRRA practitioner to make incremental improvements to their modeling techniques and therefore increase the chance the suggestions are considered and implemented. The other reason the research aimed to extend PSMs as opposed to completely deviating from them is that PSMs do have value that has been proven in actual use for years. Any critique of the current technique should not be construed to mean the research has determined PSMs have not been useful to the purpose they have been applied.

The improved model suggested by this research, called Extended Sequence Models (ESMs), will continue to result in an overall probability of success score that can

be attributed to an operational consequence level identical to the current PSM method. The probability of success will be determined by listing all activities necessary for the demonstration of a capability, also identical to the PSM technique. ESMs will continue to require Subject Matter Expert's (SMEs) knowledge and judgment to predict the performance of activities within an overall scenario and those performances will be captured in probability density functions (pdf). Identical sensitivity analysis, availability and incremental, can be performed on the ESM as performed on the PSMs. Additionally, the SMEs will still provide rationale for the scores they provide, which is one of the most important steps in the current PSM technique.

To the maximum extent possible, the only difference between PSMs and ESMs are those portions specifically improved. The first improvement allows activities to take on metrics other than success or failure, such as metrics of quality or sufficiency. The second improvement allows an activity's pdf to adjust based on the outcome of other nodes which it depends. This relationship is approximated using the techniques of linear regression to find the least squares fit for the data provided by the SMEs. These dependencies are completely determined by the SMEs and the CRRA practitioners to focus on areas they feel are most important. Third, ESMs improve PSMs by explicitly acknowledging that not all nodes represent specific activities to be accomplished, rather some represent environmental factors that are dictated by the scenario and change the ability to perform certain activities. ESMs are explained fully in the next chapter by presenting the technique in a step by step process.

To answer the third research question, "What other architectural models can be built and analyzed that would assist the CRRA?", an understanding of the current method

was acquired through reading CRRA documentation, interviewing CRRA stakeholders, and attending a PSM scoring session. From there, three architectural models were decided upon that would allow the SMEs to provide more accurate scores to ESM nodes while at the same time making the scores they provide more defensible. The creation of these architectural models is “Step 0” of the ESM construction technique. They are developed for the purpose of providing the SMEs and CRRA practitioners the most detailed and accurate information possible to increase the reliability and defensibility of the CRRA.

3.2 Summary

With an overview of the methods used to answer the research questions presented, the next chapter explains in detail the outcome of the method and provides examples of their implementation. Finally, Chapter 5 presents conclusions, recommendations, and areas for further research.

4. Analysis and Results

4.1 Introduction

This chapter begins with an explanation of architectural models that can be developed at the commencement of the Capability Review and Risk Assessment (CRRA) to improve Extended Sequence Model (ESM) construction, scoring, and execution. Following this explanation, the ESM technique is presented. To conclude the chapter, the ESM technique is tested by applying it to a portion of an Agile Combat Support (ACS) Process Sequence Model (PSM) currently in use to support the 2009 CRRA.

4.2 Architecture Framework Analysis

While there are exceptions, most DoD processes do not require the use of any specific architectural view or product. Even though they are not always required, the use of a variety of views and products can streamline product deployment and reduce confusion. There are various examples, such as DoD Directive 5000.02 and CJCSI 3170.01F Joint Capabilities Integration and Development System (JCIDS), which signify the importance of providing architecture information by requiring specific views for different development stages of a system. By using a well developed and thoroughly planned architecture, the CRRA analysis can be more understandable, more readily accepted, and more defensible under scrutiny.

A significant concern of many individuals and teams alike is that building architecture is both time consuming and ineffective. This is partially due to the mistaken belief that architecture views are built for their own sake and that they are an end product instead of an analysis tool to help the user. Volume I of the Draft DoDAF v 2.0 stresses this concept by stating

“Architecture views (formerly ‘products’) are no longer the end goal, but are described solely to facilitate useful access to information in the architecture database. All views are tailorable. The requirements for data completeness and self-consistency within the data schema are more critical than the view chosen at any particular time by a particular user. Analytics, properly conducted, represent a powerful tool for the decision-maker, ensuring that the most appropriate and current, as well as valid data is used for decision-making”

(DoD, 2008a:82).

It also takes this idea further by asserting “Architectures well designed, and consistent with the purpose for which they were created, are well suited to the analytic process” (DoD, 2008a:83). A complete list of suggested architectural views and their representations may be found in volume 2 of the Draft DoDAF v 2.0.

As part of this research, many of the CRRA stakeholders were interviewed concerning their knowledge and opinion of the architecture that surrounds the CRRA, and more specifically, the PSM analysis. Some had the mistaken belief that architecture was simply limited to DoDAF views, while others believed that using DoDAF or any other formal architecture framework would be a hindrance to the PSM analysis as they considered the architecture too “inflexible” to be useful. One stakeholder even went so far as to state how they had to “divorce themselves from the architecture” to develop a useful analysis tool. However, others believed that architecture would be highly beneficial to the CRRA analysis and were especially interested in developing architectures that could show relationships as well as redundancy. These practitioners theorized that showing relationships between required capabilities and the capabilities provided by Air Force systems and services could expose redundancies and gaps (FAT, 2008).

Chapter 2 presented how architectural products are used to assist with the construction of PSMs, namely the use of an OV-5 and OV-6c, as well as an OV-5 to

PSM traceability matrix (Eller 2008:190). Chapter 2 also presented previous work that showed the development of an OV-2 can be used in conjunction with the OV-5 to provide information about the interconnectivity and interdependence of the capabilities under examination (Eller, 2008: 26). The creation of these models is still essential to the ESM process as they tie the activities under examination to the Air Force Concept of Operations (CONOPs) and ultimately to higher level DoD guidance. However, by using the different viewpoints associated with the Draft DoDAF 2.0, a better representation of the vital information can be developed, ultimately leading to a better analysis of the capabilities. A specific example of this is the new Capability Viewpoint, which offers the ability to help the CRRA stakeholders understand the strategic and political emphasis placed on a requirement. Given there are many different capabilities available to the decision makers that potentially offer a similar end result, having the strategic guidance available will enable the CRRA practitioners to perform the best possible analysis by only considering the capabilities relevant to the scenario. For example, if the end goal is to eliminate the opposing force's early warning system, there may be multiple ways to accomplish the mission; however, knowing any political or strategic limitations may reduce the available options, thereby enabling the SMEs to only focus on mission areas and systems relevant to the scenario. A capability gap may be emphasized if previously unknown limitations (such as troop strength, number and type of aircraft, or political limitations) are divulged to PSM developers and the SMEs responsible for scoring the PSMs. For these reasons it is important to provide the SMEs with more scenario specific information.

Based on what this research was able to uncover, the scoring guidance, to include scenario assumptions and limitations, are provided to SMEs in text paragraph form. The SMEs have the daunting task of reading, interpolating, and understanding the ramifications any action or inaction would have on probability of success while putting the scenario in context with the current and future world climates. Furthermore, the text appeared to lack specific explanations of what resources would be at the disposal of the Air Force in the scenario. For example, a probability of success provided under the assumption of adequate manpower or correct configuration of airframes may not be an accurate depiction of the true probability of success. While the CRRA scenarios contain the strategic goals of that scenario, it is unclear if the strategic guidance set forth in the scenarios approved by the Office of the Secretary of Defense (OSD) is adequately explained to, or understood by, the CRRA practitioners or SMEs. Such information should be considered during the PSM construction, scoring and analysis processes.

The Capability Viewpoint (CV), can communicate various types of data, though normally they are used to relate high-level strategic information and guidance. A well-developed CV can directly state overall strategic goals, political considerations, budgetary, time or material constraints and possibly other considerations that may be applicable to the given scenario. By incorporating Capability Viewpoints into the design and development of the PSMs or ESMs, Stakeholders can ensure that strategic guidance is not lost between the approved scenarios and the PSM or ESM scoring. By presenting the developed Capability Viewpoints to the SMEs during the scoring session, SMEs may help uncover any hidden capability gaps brought out by the strategic guidance. The

research suggests a simplified strategic guidance using a CV-1, as described in the Draft DoDAF v 2.0. An example is provided in Figure 4.1.

Vision (CV-1): Imaginary Country Scenario
<p>Scenario: Imaginary Country has internal political opposition from the flourishing Authoritarian Red Party to the current ruling power (Blue Party). The United States, a strong ally of Imaginary Country and the Blue Party leadership, has a vested interest in retaining strong economic and political ties to Imaginary Country. Provide military and diplomatic assistance to the current ruling party in an effort to thwart advances of the Red Party. Due to security measures, use of in-country facilities are not optimal, nearest bed down is Another Country, 807 nautical miles due south of Capitol City, Imaginary Country.</p> <p>Objectives:</p> <ol style="list-style-type: none"> 1. Retain diplomatic and economic ties to Blue Party 2. Ensure populace not harassed into submission by Red Party 3. Retain good will and support with Imaginary Country population 4. Limit damage of current infrastructure, reducing threat to population and cost to rebuild 5. Retain diplomatic standing with current and future allies 6. Limit neighboring country strain on resources by influx of refugees from Imaginary Country 7. Limit increase in operations tempo to 125% of current operations tempo <p>Authorizations: 36,000 military personnel (8,000 Air Force, Specific AFSCs & Numbers can be listed here) 25 Aircraft [A-10 (10); B-1B (3); B-2 (2); B-52 (1); F-16 (8); KC-135 (1)]</p> <p>Limitations:</p> <ol style="list-style-type: none"> 1. Budgetary constraints 2. Manpower shortages (330,000 members - # currently deployed/scheduled for deployment) 3. Time constraints <ol style="list-style-type: none"> a. Mobilization time (Limited time to react – short notice ≈ 96 hours) b. Imaginary Country political stabilization time (≈ 24 months after height of conflict) c. Timeline for withdrawal (≈ 4 years) 4. American political climate (Military conflict unpopular) 5. World standing <p>Other Considerations:</p> <ol style="list-style-type: none"> 1. Effect on American Trade 2. Public Support for another contingency

Figure 4.1 Capability Viewpoint (CV-1)

As with any scenario, certain capabilities are required for mission success.

During the research it was discovered that, while the SMEs were asked to provide P(S) for many nodes given an identified scenario, they were not given adequate information. For example, node 23.04 in the ACS Homestation Sustainment PSM, asked SMEs to give a P(S) for “Maintain Law and Order”. No base was identified, the identified base was simply identified as “base X”, instead the SMEs were given suggested bases upon which

they should model their score and rationale. These representative bases were identified by name, but no statistics were detailed. Of course they are different in location, local populace, base population, strength, land mass and security requirements, but during the scoring it is assumed that any P(S) for base security would be the same. In the ACS Smartbook, the SMEs were instructed to consider between 60% and 75% of the base population was deployed and another 10% to 14% could not deploy or perform normally (AF/A4LX, 2008:4-7). Given that the SMEs were not informed of the initial base population, or the remaining quantity or quality (skill level) of forces, it would be almost impossible for a SME to adequately determine the level of ability to protect a military installation. This cannot be sufficiently accomplished without knowledge of personnel strength and an in-depth knowledge of base-specific security requirements. The assumptions made by the CRRA practitioners, concerning the undefined supply of the appropriate systems, personnel and facilities were seen as questionable.

If a CV-1 is adequately prepared and used to populate Systems Views (SV), the CRRA practitioners as well as SMEs can use these architectures to rationalize realistic P(S) scores. The current CRRA process literature obtained from AF/A5X-C includes mapping systems to the operational activities in the PSMs (AF/A5X-C, 2007). The completion of this step would satisfy the input requirements for generating a SV-5b. By developing SV-5 (either a or b), it is possible to see where there are system redundancies. An SV-5a has three intended functions “tracing functional system requirements to user requirements, tracing solution options to requirements, and identification of overlaps” (DoD, 2008b:249). Whereas SV-5b “maps systems requirements to user requirements, traces solution options to requirements and identifies overlaps” (DoD, 2008b:250). As

the research mentioned earlier, it was desired among the CRRA stakeholders to show redundancies. Any redundancies could be thoroughly evaluated to decide if they were necessary or unnecessary. Unnecessary redundancies could then be offered as trade space, while any gaps identified through this process could be analyzed to reveal the extent of any deficiencies. Additionally, this could be used as part of the ongoing CRRA Potential Areas to Accept Risk (PAAR) analysis discussed in Chapter 2. Furthermore, any operational activities that do not have a system mapped to it can be examined to determine by what means that activity is accomplished, potentially uncovering a capability gap.

From a well developed SV-5 that lists all the systems used to accomplish the operational activities, the CRRA practitioners should develop a SV-7 (Systems Measures Matrix) that defines performance characteristics and measures for the systems in use. By developing a SV-7, CRRA practitioners as well as SMEs can use their expert knowledge to understand what systems the scenario contains, and the associated performance metrics of those systems. Using the advanced scenario data provided will enhance the accuracy of any P(S) given by the SME while also giving the SME defensible rationale for the scores they provide. Additionally, the CRRA practitioners can see and understand functional redundancies as well associated gaps between the systems. The following SV-7 in Table 4.1 was populated with both type and number of aircraft, along with the performance measures of the aircraft, for operation in the Imaginary Country scenario. Aircraft and their capabilities are presented here as an example; however, this can be adapted to describe any type of system or service and the performance characteristics they provide or contribute. Using this viewpoint, numbers, types and configurations of

aircraft (for example) can be modified to provide the best combinations using the least amount of resources.

Table 4.1. Systems Measures Matrix (SV-7)

Systems Measures Matrix (SV-7): Imaginary Country Scenario							
Number of Aircraft:	10	3	2	1	8	0	1
Type of Aircraft:	A-10	B-1B	B-2	B-52	F-16	F-22A	KC-135
Range	695 nm	6,478 nm	6,000 nm	7,652 nm	1,740 nm	1,600 nm	1,500 nm
Cannon	30 mm				20 mm	20 mm	
Ground Support	Yes				Yes	Yes	
Nuclear Weapons		No ¹	Yes	Yes			
Mixed Ordnance	16,000 lbs	75,000 lbs	50,000 lbs	70,000 lbs	20,450 lbs	Unknown lbs	
Naval Support (mines)		Yes		Yes			
Missiles				Yes	Yes ²	Yes	
Rockets	Yes					Yes	
Transferable fuel load:							200,000 lbs

¹ START Treaty Requirement

(Air Force Fact Sheet, 2008)

² Air-to-air, Air to ground, Anti-Ship

Items in Red, may not meet minimum capability requirements as defined in CV-1

As with any form of communication, care must be taken to not overload these viewpoints with superfluous information. These viewpoints are meant to be a simplified reference so decision makers can base their scores on set parameters that may differ between scenarios.

These suggestions are not intended to indicate an exhaustive list, or lead the reader to the conclusion that these are the only applicable views useful for CRRA

analysis; a detailed evaluation of the draft DoDAF v 2.0 and its associated viewpoints would be beneficial to the CRRA process.

A common complaint among many of the CRRA practitioners concerned the lack of centralized software that was core to the development, planning and scoring of the CRRA process. Currently, there is no single software that holds the entire architecture utilized by the CRRA. A combination of many types of software is used to accomplish different parts of the CRRA process. Software products such as ProVision, Word, Excel, Visio and Power Point, to name a few, are used to input, manipulate, store and produce the desired output. Integration of DoDAF v 2.0 compliant architecture is important to adequately develop and score the CRRA. DoDAF v 2.0 compliant software should be purchased or developed to provide a central repository for AF architecture used by the CRRA, to include the scoring and analysis portions. By having a central repository, development, manipulation and analysis of the architecture could be readily accessed and further analyzed iteratively and continuously.

There are two types of architectural analysis, static and dynamic. Static analysis is based on data which has been extracted from the architecture, such as historical data used to develop future trends. This usually uses simpler tools such as visual comparisons. Conversely, Dynamic analysis is “running” a version of architecture which has been developed as an executable model to evaluate performance or run multiple variables in different situations (DoD, 2008a:83). The viewpoints suggested have been static architecture. ESMs, which are discussed in the next section, are a type of executable dynamic architecture that has been specifically developed to analyze the CRRA.

4.3 Modeling capabilities using ESMs

This section will present a technique called Extended Sequence Models (ESM) that allows the CRRA practitioners to uncover and examine the dependencies of activities within the modeled system. Additionally, the technique can account for sufficiency of capability or quantity of assets to examine how it affects operational risk while more formally identifying what nodes represent activities that are part of a process and what nodes represent environmental conditions of the scenario. Current PSMs cannot account for any of these conditions. While this research aims to suggest methods that are useable, the usability of the ESM techniques will have to be determined by the CRRA practitioners.

This section is presented as a methodology the CRRA practitioner can follow to successfully perform the technique. Figure 4.2 gives an overview of the method that will be described.

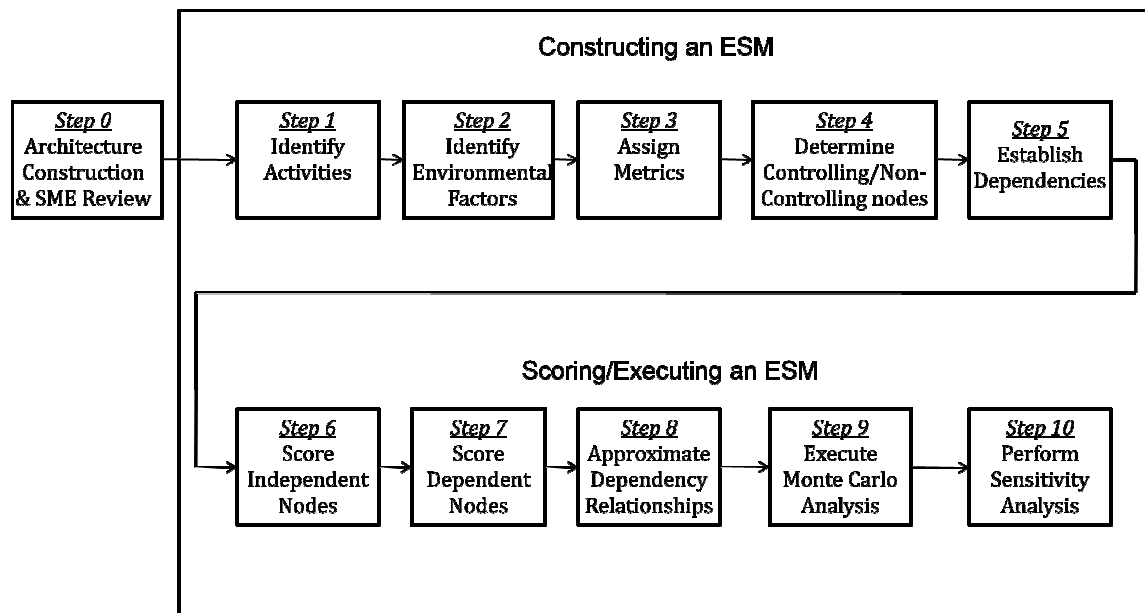

Figure 4.2 ESM Implementation

Step 0 of this process has already been described in the previous section. The creation of architectural products to adequately prepare the SMEs to provide the most accurate input possible is a critical preparatory step. The ESM methodology continues to the construction of the model framework. This can be accomplished by a separate group of SMEs from the scoring SMEs or it could be the same group of experts if the CRRA practitioners so decide.

Step 1: The first step to creating the framework is to identify all activities that must be accomplished for the successful completion of the mission under examination or the successful demonstration of the capability. This step is accomplished in the current method and is supported by an adequate architecture's OV-5 and OV-6c.

Step 2: Environmental factors are then identified. Environmental factors are different from activities in that they are not performed. They are conditions of the environment the activities are being performed in. Examples of environmental factors might be the security environment measured by attacks per day or weather conditions such as visibility in miles.

Step 3: Each activity and environmental condition should be evaluated to determine the metric that will be used to describe it. Currently, every activity is measured by probability of success. That might remain the dominant metric, however, tasks that don't clearly fit the success or failure assumption can be assigned another metric. For example, a training activity can have the measurement *Number of Airmen Trained* or a supply activity could measure *Number of Parts Ordered*. The metric doesn't even have to be one of quantity; it could be one of quality. For example, an activity titled *Establish communication link* can have a metric *Percent of time*

communication link available. The metric should be chosen based on two criteria. The first is whether it will likely affect the successful completion of the mission or capability. The second is whether the CRRA practitioners determine examining that metric is valuable.

Step 4: Once all activities and environmental factors are identified and assigned a measurement variable, they are divided into two categories. The first group contains those nodes that have an outcome that other activities depend on; this group will be called the ‘controlling’ nodes. Controlling nodes can have any type of measurement variable. The outcomes of the controlling nodes contribute to the overall probability of success of the mission only indirectly through their affect on other nodes. The second group contains those nodes that have an outcome that doesn’t affect other nodes; the outcomes of these nodes directly affect the successful completion of the overall mission. This group will be called ‘non-controlling’ nodes and can only contain nodes whose measurement variable is probability of success. This is obviously a subjective process. With some careful thought, almost every activity can result in performance differences in other activities. The goal is to find the balance that allows more dependencies to be uncovered than the current method allows, while keeping the technique usable and accessible to the CRRA community. The increase of represented dependencies greatly increases the number of scores SMEs are required to provide, as will become apparent in the following paragraphs.

Step 5: The controlling nodes need to be linked to the nodes they influence. The graphical way to represent this link is to draw a dotted arrow from the controlling node to the node that is depending on it. This is consistent with the Unified Modeling Language

(UML) technique to show a dependency relationship (Larman, 2002:295). Controlling nodes can be linked to other controlling nodes creating chains of controlling nodes; however, eventually they need to link to a non-controlling node whose metric is probability of success. The controlling nodes that are intermediary nodes in the chain can have any type of metric just like any other controlling node. Additionally, it is acceptable to have non-controlling nodes that have no dependencies.

The construction of the model might require controlling node variables to be combined in a way other than through dependency relationships. To handle this situation a Function Node can be inserted with the appropriate logic assigned to it. The Function Node transforms input variables, provided by controlling nodes (graphically shown by solid arrows), through a function to an output required by other nodes, an example of a function node is presented in Figure 4.3. A complete list of model components, their symbols, and definitions is presented in Appendix A.

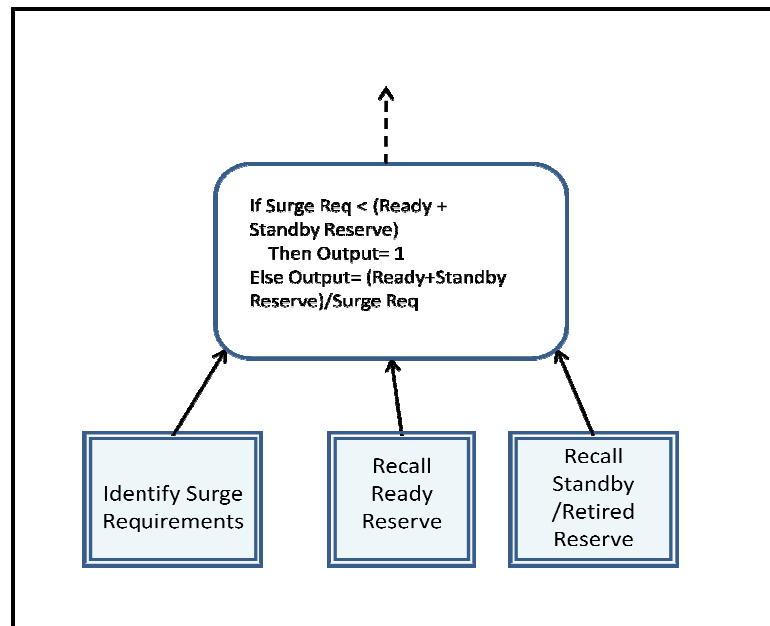

Figure 4.3: Example of a Function Node

Step 6: At this point the model's framework has been constructed. The next step is populating the nodes with probability density functions provided by the scoring SMEs. The SMEs will start with activities that are not dependent on any other activity; these are the independent nodes. If the activity's measurement variable is probability of success, the SME will "score" the node identical to the current method by providing a most likely, worst case, and best case value. Activities that have measurement variables other than probability of success will be handled very similarly. The SME's will determine the most likely value of that variable, the greatest value the variable would attain, and the lowest value that the variable would likely attain, given the scenario.

Step 7: Following the scoring of the independent nodes SME's attention turns to the dependent nodes. Dependent nodes are those nodes whose probability density functions depend on the outcome of one or more controlling nodes. The SMEs provide scores for the dependent node based on the value of the controlling nodes. For example, SMEs decide the probability of successfully on-loading cargo and passengers to an airlift mission in the time required depends on the amount of passengers and cargo to be loaded. Based on the scenario and the airframe in question SMEs determine, in step 6, the range of passengers could be between 0 and 92 while the range of cargo is likely to be in the range of 10 to 20 tons with some most likely value for passengers and cargo as shown in Figure 4.4.

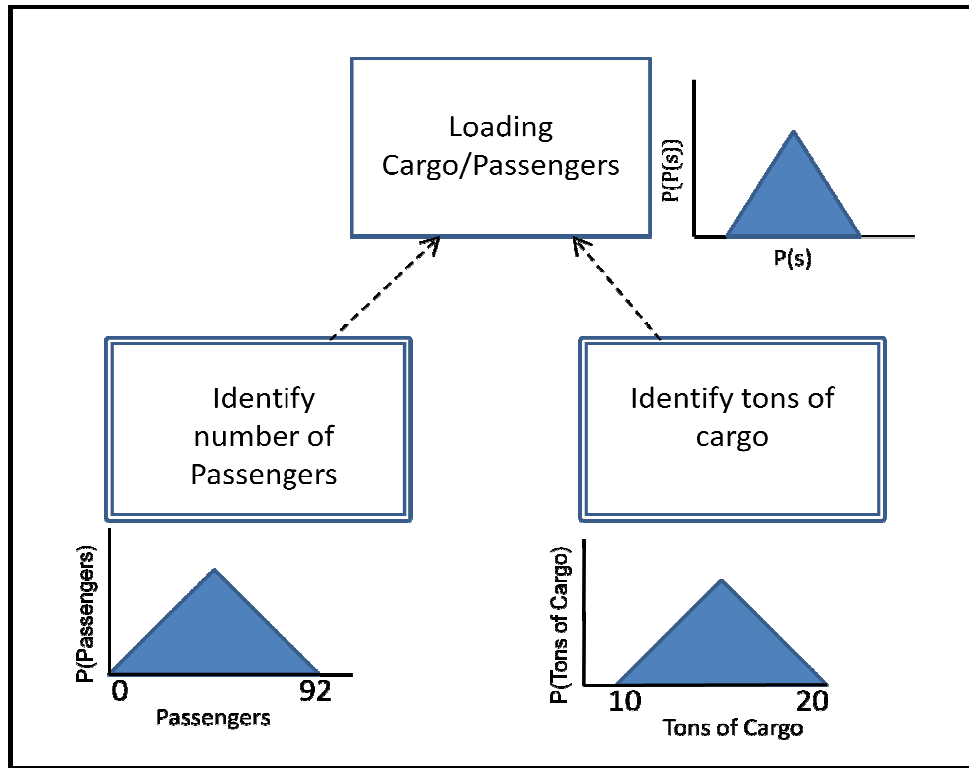

Figure 4.4 ESM Example

SME's then provide the probability of successfully on-loading cargo and passengers based on the extremes of the controlling nodes. If a dependent node is dependent on n controlling nodes the SMEs need to provide at least $(n+1)$ scores to fully describe what the response will be to the dependent node. Each of the scores should correspond to a unique combination of values for the controlling nodes. For the example in Figure 4.4, the dependent node *loading Cargo/Passengers* is dependent on two nodes, therefore the SMEs have to provide **at least** three probabilities. For this example, the SMEs determine the most likely probability of success for loading the cargo and passengers is 0.97 given there are 0 passengers and 10 tons of cargo. Similarly, the SMEs determine the most likely probability of success is 0.90 given there are 92 passengers and 20 tons of cargo and they provide a most likely probability of success of 0.93 given 0 passengers and 20

tons of cargo. The SMEs also provide an upper and lower bound around the score they provide. This creates the triangular pdf and represents the uncertainty they have in the score they provided. These SME responses are depicted in Figure 4.5.

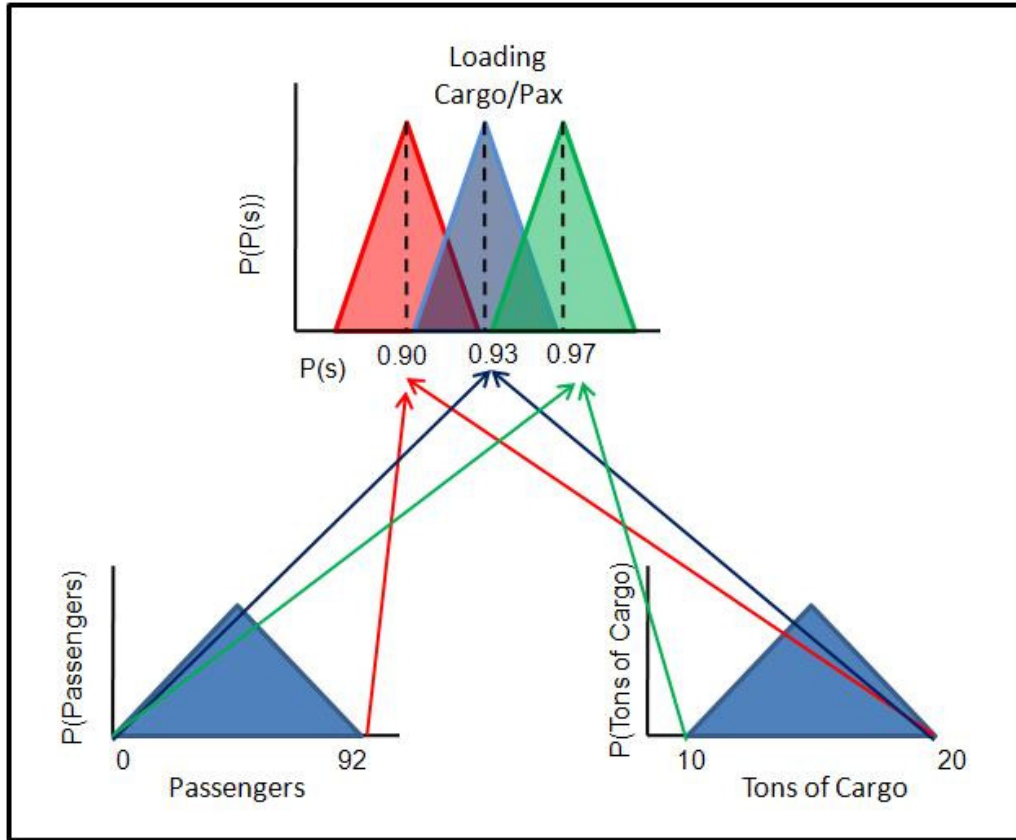

Figure 4.5 Most likely Probability value dependence on two controlling nodes

The technique presented above results in the minimum data collection needed to complete the model. More specifically, it requires $(n+1)$ scores from the SMEs for each node where n is the number of controlling nodes. By mandating that the probabilities provided by the SMEs are based on the extremes of the possible variable ranges of the controlling nodes, this model guarantees linear independence of the controlling node samples and prevents an underdetermined situation that would not result in a dependency equation. However, the technique can be expanded to accept an increase in data points.

Instead of only looking at the extremes of the controlling node variables, SMEs can provide probabilities of success for points somewhere between the extremes of the independent variable range. Additionally, for the same input variables multiple SMEs could provide differing probability of success that will all be taken into consideration when approximating the relationship in step 8.

While obtaining more data points, care must still be taken to ensure the minimum requirements are met as to not create an underdetermined situation. This can be accomplished by the scoring facilitator choosing the values of the controlling nodes that the SMEs will use to determine the score they assign. Any scores within the range of possible values of the controlling nodes can be selected. The scoring facilitator needs only ensure the rank of the input variable matrix \mathbf{X} , is equal to or greater than $(n+1)$ where n is the number of controlling nodes. The minimal method presented earlier ensured the rank equaled $(n+1)$ by selecting the lowest value for all the variables, the highest value for all the variables, then a mix of highest and lowest until the minimum number of scores had been collected from the SMEs. One way to guarantee the rank is great enough is to follow the minimal method presented above by selecting the extremes of the variable ranges. Only after that method is accomplished the scoring facilitator can start choosing values for the controlling nodes that are somewhere in between the extremes. This ensures the problem is over determined and a least squares fit can be accomplished to find the linear regression (Johnson, 1993: 207).

Step 8: The relationship between the controlling nodes and the nodes they control is then approximated based on the input provided by the SMEs in step 7. For the general case we are trying to find a linear approximation to the relationship that takes the form:

$$P_i(s) = \beta_{i,0} + \beta_{i,1}X_1 + \beta_{i,2}X_2 + \cdots + \beta_{i,n}X_n$$

Where, $P_i(s)$, is the probability of success for node i , X_1 , is the value of the first controlling node, X_2 is the value of the second controlling node, and X_n is the value of the n^{th} controlling node. The β values are the equation parameters that control the weight or strength each controlling node has on the final probability where $\beta_{i,n}$ is the n^{th} parameter for the i^{th} node.

For the example shown in Figure 4.5, the relationship between probability of successfully on-loading cargo and passengers based on the quantities of passengers and cargo to be loaded is described by the equation:

$$P_1(s) = \beta_{1,0} + \beta_{1,1}X_1 + \beta_{1,2}X_2 \quad (7)$$

Where X_1 and X_2 are the values of the controlling nodes (X_1 = Number of passengers, X_2 =tons of cargo).

SME's are asked to provide probability of success scores based on various values of the controlling nodes. This yields a system of linear equations:

$$\begin{aligned} P_{i,1}(s) &= \beta_{i,0} + \beta_{i,1}X_{1,1} + \beta_{i,2}X_{2,1} + \cdots + \beta_{i,n}X_{n,1} \\ P_{i,2}(s) &= \beta_{i,0} + \beta_{i,1}X_{1,2} + \beta_{i,2}X_{2,2} + \cdots + \beta_{i,n}X_{n,2} \\ P_{i,3}(s) &= \beta_{i,0} + \beta_{i,1}X_{1,3} + \beta_{i,2}X_{2,3} + \cdots + \beta_{i,n}X_{n,3} \\ &\vdots \\ P_{i,m}(s) &= \beta_{i,0} + \beta_{i,1}X_{1,m} + \beta_{1,2}X_{2,m} + \cdots + \beta_{i,n}X_{n,m} \end{aligned}$$

Where $P_{i,m}(s)$ is the i^{th} node's score for the m^{th} trial while $X_{n,m}$ is the n^{th} controlling node's value for the m^{th} trial.

For the case where exactly $(n+1)$ scores have been provided by the SMEs to define a relationship between a dependent node and n controlling nodes with n

dependent relationships, the SME responses yield a system of $(n+1)$ linear equations.

The equations for the example in Figure 4.5 are:

$$0.97 = \beta_{1,0} + \beta_{1,1}(0) + \beta_{1,2}(10)$$

$$0.90 = \beta_{1,0} + \beta_{1,1}(92) + \beta_{1,2}(20)$$

$$0.93 = \beta_{1,0} + \beta_{1,1}(0) + \beta_{1,2}(20)$$

The values of $\beta_{1,0}$, $\beta_{1,1}$ and $\beta_{1,2}$ that satisfy the equations need to be found. A simple way to find these values is by using matrices where (Neter, 1996:227)

$$\mathbf{Y} = \begin{bmatrix} 0.97 \\ 0.90 \\ 0.93 \end{bmatrix}$$

$$\mathbf{X} = \begin{bmatrix} 1 & 0 & 10 \\ 1 & 92 & 20 \\ 1 & 0 & 20 \end{bmatrix}$$

$$\boldsymbol{\beta} = \begin{bmatrix} \beta_0 \\ \beta_1 \\ \beta_2 \end{bmatrix}$$

$$\text{Then: } \mathbf{Y} = \mathbf{X}\boldsymbol{\beta}$$

$$\boldsymbol{\beta} = \mathbf{X}^{-1}\mathbf{Y} \quad (8)$$

The technique used to find the values of \mathbf{X} and \mathbf{Y} guarantees \mathbf{X} will be a square matrix with linearly independent rows in \mathbf{X} . This allows us to perform equation 8 without concern whether \mathbf{X} is invertible or that \mathbf{X} and \mathbf{Y} matrices will not multiply (Johnson, 1993: 54,96).

The example would produce:

$$\begin{bmatrix} \beta_0 \\ \beta_1 \\ \beta_2 \end{bmatrix} = \left(\begin{bmatrix} 1 & 0 & 10 \\ 1 & 92 & 20 \\ 1 & 0 & 20 \end{bmatrix} \right)^{-1} \begin{bmatrix} 0.97 \\ 0.90 \\ 0.93 \end{bmatrix} = \begin{bmatrix} 1.01 \\ -0.0003 \\ -0.004 \end{bmatrix}$$

We can now update Equation 7 for this node with:

$$\text{Probability of Success} = 1.01 + (-0.0003)X_1 + (-0.004)X_2$$

This is scalable to any number of controlling nodes; however each new controlling node requires the SMEs provide another probability of success relationship.

To handle the situation where the SMEs provide some number of scores greater than $(n+1)$, a linear regression is computed using the same least squares technique above however using the generalized equation. Once the matrices of \mathbf{Y} and \mathbf{X} are developed, the equation parameters, $\boldsymbol{\beta}$ must be found such that $\|\mathbf{Y} - \mathbf{X}\boldsymbol{\beta}\|$ is minimized. Equation 8, which is presented again below, was used in the minimal data point method to find the equation parameters, $\boldsymbol{\beta}$. This equation cannot be used for the over-constrained case with greater data points because we cannot guarantee that \mathbf{X} is square or invertible. This causes equation 8 to be undefined. Therefore, the pseudo inverse is used to find the generalized equation for $\boldsymbol{\beta}$ presented as equation 9 (Neter, 1996:227).

$$\begin{aligned}\boldsymbol{\beta} &= \mathbf{X}^{-1}\mathbf{Y} \\ \boldsymbol{\beta} &= (\mathbf{X}'\mathbf{X})^{-1}(\mathbf{X}'\mathbf{Y})\end{aligned}\tag{9}$$

As mentioned above, because the expanded data collection method allows for a large number of SME scores, the CRRA practitioner can also decide to have multiple SMEs determine their own scores. Different SMEs will undoubtedly provide slightly different probability scores given the same group of input. This method creates a best fit relationship thus aggregating their inputs to arrive at a single linear model.

It might be decided in future iterations of the CRRA that obtaining multiple data points from many SMEs is more desirable than the current method of getting consensus on one score. This could prevent a group think mentality where an inaccurate score is presented based on the dynamics and pressures within the group. Another benefit to

using this expanded method is it can be less time consuming than getting agreement on a minimal set of scores from many people. Additionally, more data points could be acquired from individuals who are not able to attend the scoring session in person. It is possible that tens or even hundreds of individuals across the Air Force, from Airmen working on the flight line to Wing Commanders, could provide their perspective on a node they have experience with to provide a more complete understanding of the dependency relationships.

The example above shown in Figure 4.5, was used to find the ‘most likely’ or mode of the pdf for on-loading the passengers and cargo. To complete the triangular pdf, an upper and lower bound must be determined. The technique of approximating a linear relationship could be repeated two additional times to find the response on the highest and lowest bounds based on controlling node values. This would allow the width of the triangular distribution to change based on the controlling variables; however, this would also require additional input from SMEs and additional calculations to execute the model which requires additional resources to complete the analysis. Therefore, assuming the bounds of the probability density function respond identical to the ‘most likely’ value is appropriate. The SMEs would determine an upper and lower bound around the highest possible value for the mode. The width of that range would stay constant as the most likely value shifts. In the example of Figure 4.5, the SMEs determined 0 passengers and 10 tons of cargo would result in a most likely probability of success of 0.97. The SMEs would then provide an upper and lower bound. If the SMEs determined the bounds were 0.95 and 0.99, then as other combinations of input variables creates different most likely probability distributions the upper and lower bounds would remain 0.02 above and below

the mode. For example, if there were 45 passengers and 13 tons of cargo the model would produce a most likely probability of 0.945. The lower bound would be 0.965 and the upper bound would be 0.925.

Step 9: Similar to the current PSM approach, a Monte Carlo analysis is performed. It starts by selecting a value for all independent nodes from the triangular distributions provided. In the generic model presented in Figure 4.6, values are selected for nodes 3, 5, and 6. Once the values are selected the probability distributions are defined for nodes influence by those outcomes. The probability density function for node 2 and node 4 would be found based on the outcome of nodes 5 and 6 respectively. At that point, the simulation selects values for those nodes whose probability distribution has been calculated (nodes 2 and 4 below).

This continues to roll up until all non-controlling nodes (nodes 1, 2, and 3) have a value selected. Non-controlling nodes must have a measurement variable of probability of success; therefore, the overall probability of success for the mission is found by evaluating the probabilities of the non-controlling nodes. If the nodes are presented in a series, all nodes must be successful for the entire mission to complete successfully. To find the total probability, the probabilities of the nodes are simply multiplied to find the total system probability; however, it is also possible to include redundant nodes. In this case, the total probability would be calculated using equation 2 and equation 3. Shown again here:

$$P(S)_{Total} = P_A(S)[P_B(S) + P_C(S) - P_B(S)P_C(S)]$$

$$P(S)_{Total} = (1 - \prod_{i=1}^n (1 - P(S)_i)) \quad (10)$$

Non-controlling nodes in an ESM don't necessarily have to be arranged as a process. This is because each of the non-controlling nodes could represent an activity that is ongoing throughout the course of the evaluation period. Either solid lines or branched lines are drawn between the non-controlling nodes to represent whether the total reliability is calculated using the series approach of multiplying all the probabilities or calculated as redundant nodes using equation 10. Both types of non-controlling node connectors can be seen in Appendix A. The example in Figure 4.6 shows a series configuration.

Additionally, the diamond shaped decision nodes are handled in the same way as the current PSM method as explained in equation 4, although in this method they are not called decision nodes. For use in PSMs, as well as ESMs, the decision nodes rarely represent decisions; they more often represent the percent of time various nodes are involved or not based on the conditions of the scenario. The diamond shaped nodes determine how often a node is active. Therefore, they have been renamed Activating nodes as they activate other nodes some fraction of the time. The final probability equation for Figure 4.6 is:

$$P(S)_{Total} = P_1(S)[A(No)P_2(S) + A(Yes)P_3(S)] \quad (11)$$

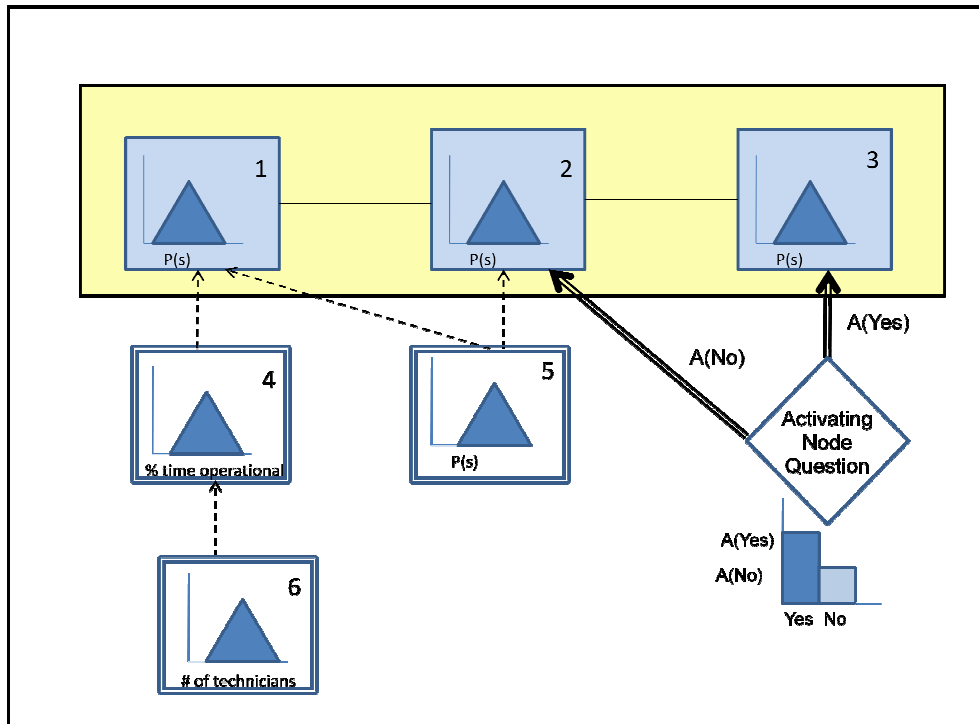

Figure 4.6 ESM Generic Example

Step 10: Section 2.3 described the sensitivity analyses that are performed on PSMs to determine which activities' outcomes have the greatest impact on the overall mission probability, and ultimately the mission consequence and risk. This is a crucial step, possibly more important than finding overall mission probability, because it assists with deciding what areas need additional resources in the future. The current method accomplishes this sensitivity analysis using two methods, availability and incremental. ESMs accomplish these two analyses in the same way.

To accomplish the availability method, all nodes are kept at their most likely value except for the node under examination. If the node has a measurement variable of probability of success its score is increased by half the difference between its most likely value and 1.0. This is identical to the current technique (FAT, 2008). If the

measurement variable is not probability of success, the measurement variable is evaluated at its least value and its greatest value to determine the difference in overall risk.

The incremental technique is accomplished identically to the current technique. The equation that describes the probability of success for the entire mission is identified, and partial derivatives of that equation with respect to individual nodes, are used to determine which node has the greatest associated sensitivity. It was presented in equation 11 above that the overall probability of the model in Figure 4.6 is:

$$P(S)_{Total} = P_1(S)[A(No)P_2(S) + A(Yes)P_3(S)]$$

We can further expand this equation by recognizing that

$$P_1(S) = \beta_{1,0} + \beta_{1,4}P_4(S) + \beta_{1,5}P_5(S)$$

$$P_4(S) = \beta_{4,0} + \beta_{4,6}P_6(S)$$

$$P_2(S) = \beta_{2,0} + \beta_{2,5}P_5(S)$$

Where α and ζ represent the equation parameters for the other two nodes.

Inserting all of these into equation 11 results in:

$$P(S)_{Total} = (\beta_{1,0} + \beta_{1,4}(\beta_{4,0} + \beta_{4,6}P_6(S)) + \beta_{1,5}P_5(S))(A(No)(\beta_{2,0} + \beta_{2,5}P_5(S)) + A(Yes)P_3(S))$$

This equation shows the relationship of the total probability of success based on the outcome of the lowest level nodes. Each partial derivative may be found with respect to each node. The node whose partial derivative has the greatest magnitude is the driving node. While this example shows the sensitivity analysis done at the lowest level it could be accomplished at any level. For example, the sensitivity analysis could have been accomplished at the top level represented by the equation 11 to determine which of the top level nodes have the greatest influence on the outcome.

4.4 ESM Assumptions

In addition to assuming a linear relationship between controlling and non-controlling nodes, the ESM method also assumes that the only dependencies between nodes are the ones presented in the model; the nodes are independent from each other in all other ways. The current method assumes *all* nodes are independent from each other. As explained earlier, with some careful thought dependencies can be found between many nodes; this new method allows the CRRA practitioner to identify the dependencies that could be important to the analysis and examine them while continuing to assume independence with other nodes.

ESMs assume that the dependency relationships can be modeled as linear. In reality, the relationship between two variables might not be linear. By making this assumption, ESMs attempt to identify a first order approximation and builds on the current PSMs that don't allow any dependencies.

It is important to recognize this model does not explicitly show a process, even if the activities in the ESM are accomplished within a process. It shows the activities that must be completed to successfully complete the mission as well as factors dependent on those activities. Some or all of these activities might occur simultaneously or they might not. The ordering of some activities can be inferred when the performance of an activity is dependent on the outcome of another discrete activity. This is a byproduct of showing dependencies. Therefore, in missions where there are discrete activities accomplished in a process and timing information is of importance to the CRRA practitioner, it would be important to construct the ESM to show the ordered accomplishment of activities while also showing the dependency relationships activities have on each other. Even in such a

case the probability of success of activities can still be related to environmental factors using the techniques described in this new method without any change to the technique described.

Another assumption is that the only effect controlling nodes have on the overall probability of success is indirectly through their influence on the non-controlling nodes. This assumption is valid because in the case a controlling node does directly impact the probability of success of the overall mission, a new non-controlling node can be added that is dependent on the controlling node in question and captures the direct influence that was identified. In the example of Figure 4.4, the tonnage of cargo impacted the probability of successfully loading the cargo and passengers in a timely manner. If it is decided that the tonnage of cargo also has a direct affect on the overall probability of success of the mission, e.g. the lower the tonnage the less likely the mission will succeed, then a new non-controlling node could be added called *Enough cargo to complete the mission*, and its probability of success can be linked to the *tonnage of cargo* controlling node. This way, while the tonnage drops and increases the probability of loading the cargo and passengers, it decreases the probability of having enough cargo to complete the mission.

4.5 Verification of the Model

For the purpose of gaining a better understanding of how this model and its supporting method would be implemented, a test of the model was conducted. A small portion of the 2009 ACS Homestation Readiness PSM was selected for the test. A review of this PSM resulted in the identification of several nodes that lent themselves to the exploration of how sufficiency or quantity can be captured and dependencies shown.

The nodes selected were *Identifying Surge Requirements* (3.01), *Recall Selected/Ready Reserve* (3.03), and *Recall Standby/Retired Reserve/IRR* (3.05). It was decided that determining how many Airmen are needed and how many Airmen are obtained through the reserves could shed more light on the probability of completing the mission than simply identifying the likelihood of successfully identifying the number of Airmen required and the likelihood of successfully filling that number.

The logic of the current PSM method broke down when applied to the *Recall Standby/Retired Reserve*. The current method calls for each node to be scored as if all previous nodes were successful. If that is the case, then there would be no need to Recall Standby/Retired Reserve because the previous node *Recall Selected/Ready Reserve* would have already provided all required Airmen. Obviously there are important dependencies between these nodes that are not captured in the current PSM models. Additionally, the percent of the required surge that gets filled can affect the successful completion of nodes that require the use of those reservists. For all of these reasons, these nodes lent themselves to being evaluated with the proposed ESMs. Nodes were selected to show how the quantity of Airmen recalled will affect the overall probability of success. The nodes selected for this were from the Flying Training Block, *Generate Training Mission* (8.02), *Undergraduate Flying Training* (8.03), *Graduate Flying Training* (8.04), *Mission Flying Training* (8.05), and *Flying Deployment Training* (8.06). Next, it was decided that showing the use of the activation node would be beneficial. Therefore, *Acquire Material?* (5.05) and the node it activates *Obtain Material* (5.06) were included in the model. Lastly, ESMs can take into consideration environmental factors that might have an impact on the overall probability of success; this allows the

CRRA practitioner to evaluate the importance of those environmental factors. To provide an example of this new feature, the *Force Protection Condition* (FPCON) is included. The resulting model is shown in Figure 4.7.

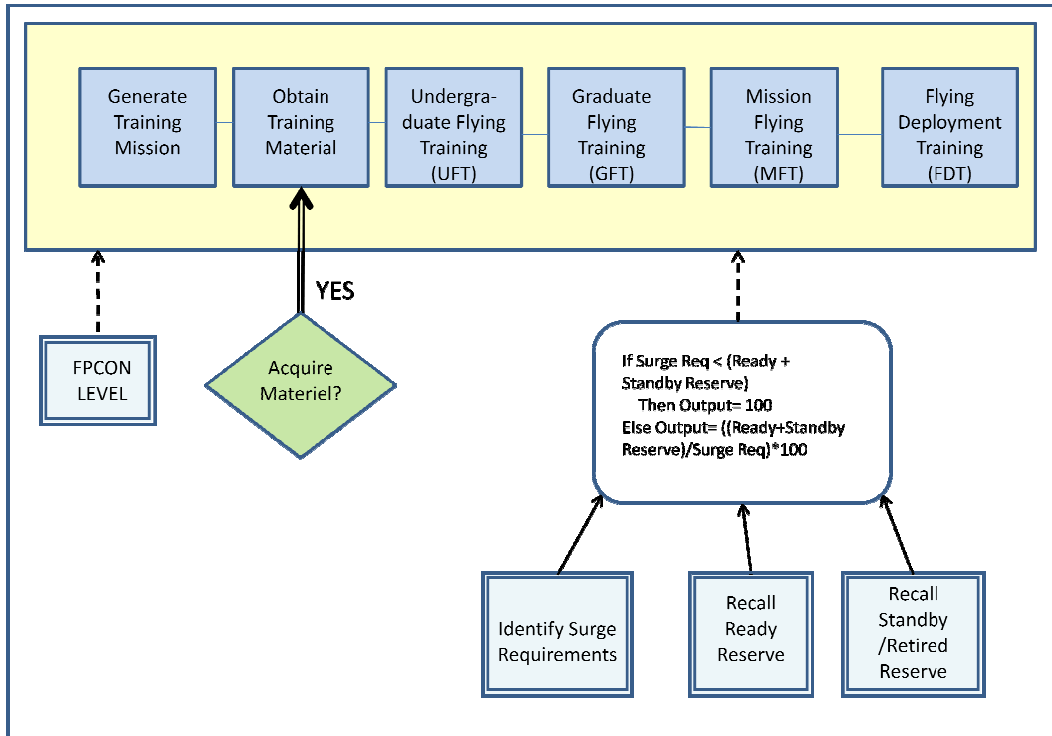

Figure 4.7 Model Verification of a segment of ACS ESM

A function node was used to handle the relationships between surge requirements and reserves recalled. The non-controlling nodes are dependent on the percent of the surge requirement filled. If the surge requirement is less than the number of people that can be obtained through both forms of reserves, the percentage is 100% filled. If the surge requirement is greater than the number of people that can be supplied from the reserves, the percent filled is calculated and used to control the probability of success of all non-controlling nodes.

With the model framework established, two mock SMEs were selected to score the nodes. It should be emphasized these SMEs were not actually experts in the areas

they scored. The scores presented are notional and in no way should be considered indicative of actual Air Force capability or deficiency. A scenario was presented to the SMEs and a series of questions were asked to obtain scores for the model. Their answers were then input to a computer program developed in MATLAB® during this research to generate the overall probability of successfully completing all of the non-controlling nodes and the sensitivity each node has on the overall probability of success. The MATLAB® code is presented in Appendix B. The complete lists of questions asked of the SMEs and the answers they provided are presented in Appendix C. A sample of the questions and answers is presented below.

Table 4.2. SME questions and responses

Identify Surge Requirements (reported in numbers of people)	
Given the scenario, what is the lowest likely number of surge personnel required?	20
Given the scenario, what is the most likely number of surge personnel required?	60
Given the scenario, what is the largest likely number of surge personnel required?	80
Recall Ready Reserve (reported in numbers of people)	
Given the scenario, what is the lower limit on the expected number of Ready Reserve that can be recalled?	0
Given the scenario, what is the expected number of Ready Reserve that can be recalled?	30
Given the scenario, what is the upper limit on the expected number of Ready Reserve that can be recalled?	40
Recall Standby/Retired Reserve (reported in numbers of people)	
Given the scenario, what is the lower limit on the expected number of Standby/Retired Reserve that can be recalled?	0
Given the scenario, what is the expected number of Standby/Retired Reserve that can be recalled?	2
Given the scenario, what is the upper limit on the expected number of Standby/Retired Reserve that can be recalled?	5

Based on the input from the SMEs, triangular probability density functions (pdfs) were established and 10,000 samples were taken from each. 10,000 samples were taken to consistently provided samples across the entire range of possible inputs. For example, because of the low probability of obtaining samples of 20 or 80 in the *Required Surge Distribution* presented in Table 4.2, less than 10,000 runs would consistently produce sample sets that never include 20 or 80. The number of runs will have to change for future applications of this method to ensure the full range of possible inputs is represented. Histograms of the values of each of the samples are presented in Figures 4.8, 4.9, and 4.10.

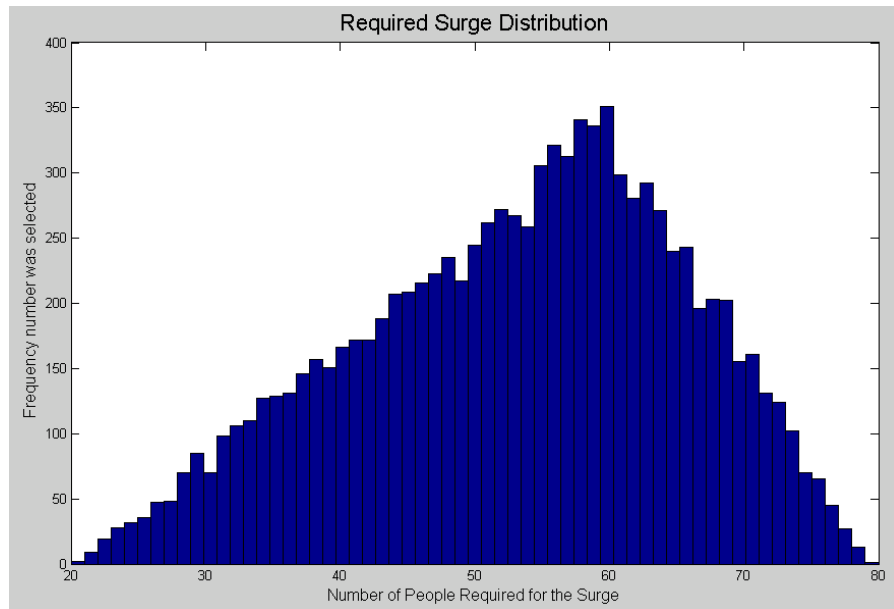

Figure 4.8 Required Surge Distribution

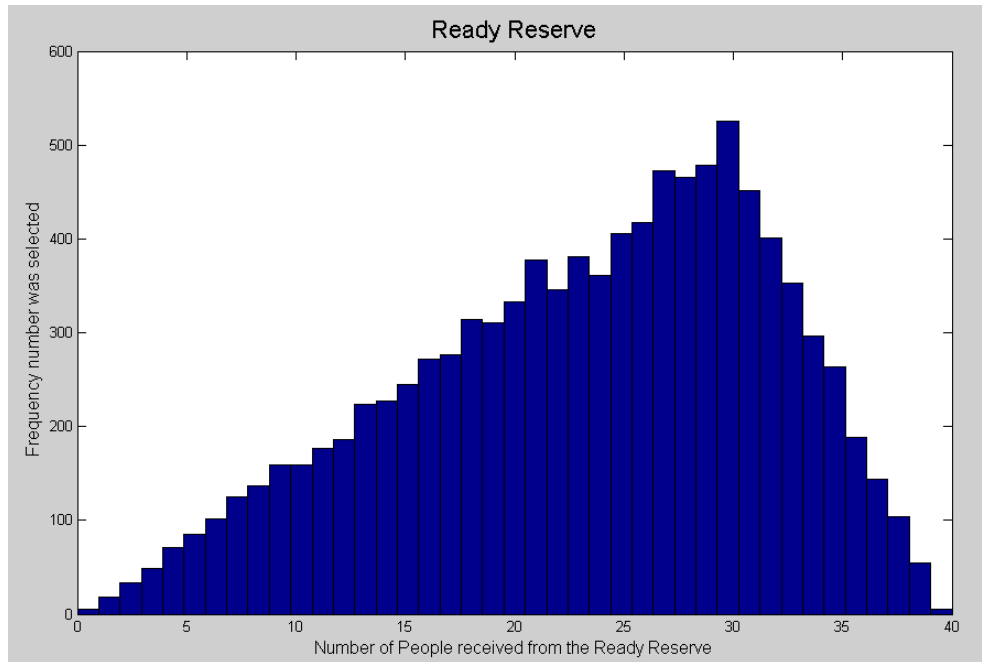

Figure 4.9 Ready Reserve Distribution

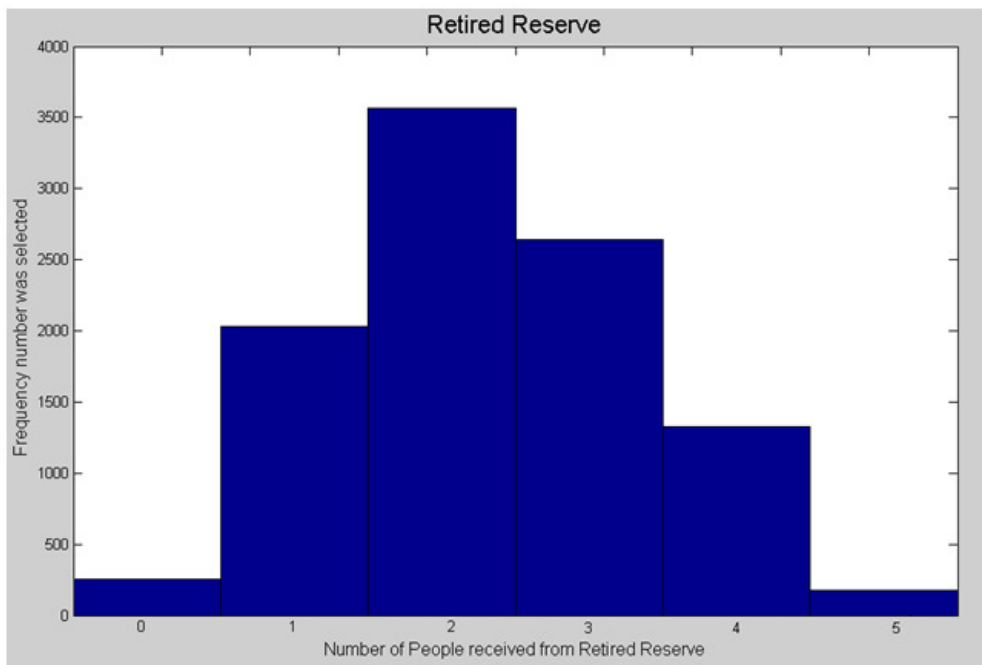

Figure 4.10 Retired Reserve Distribution

The sample values presented above were used to find the percent of the requirement filled for each sample group. The result is presented in Figure 4.11.

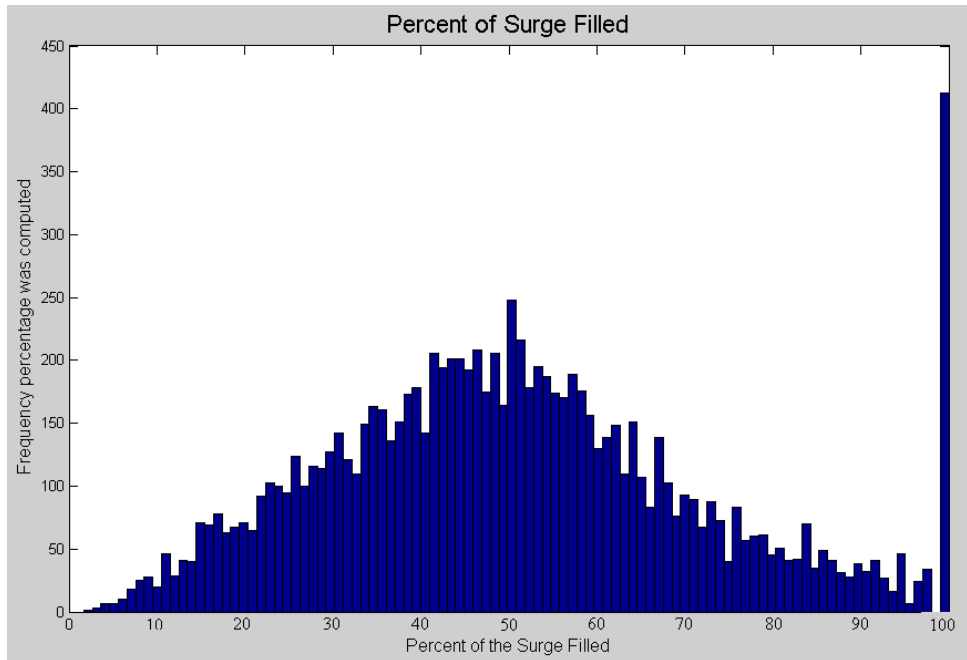

Figure 4.11 Percent of Surge Filled

Figure 4.11 shows that the vast majority of runs (approximately 9,600 of the 10,000 runs) produced less than 100% of the required surge. This is true even though more runs equaled 100% than any other single percentage. This can be seen by the large bar located at 100 in Figure 4.11. The reason so many more runs resulted in 100% is that for all situations where the number of people required for the surge was less than the number of reservists that could be recalled the percentage was assigned 100%. Without this rule, Figure 4.11 would have values that extend beyond the 100% mark. Being able to recall more than what is required is not important to the effects on the dependent nodes because it was assumed only the number of reservists required would actually be recalled. Therefore, the ability to recall more than the number required represents 100% of the required number recalled.

The relationships between each of the non-controlling nodes and the percent of surge filled and FPCON were found by asking the SMEs to score each non-controlling node based on the different values of the controlling nodes. The SMEs also provided the bounded range on the pdf for each non-controlling node. The bounded range presents the SMEs uncertainty of the P(S) they provided. A sample of the questions asked and the SME answers are presented in Table 4.3. The complete questions and answers are presented in Appendix C.

Table 4.3 SME dependency questions and responses

Generate Training Mission			
What is the probability of Successfully completing 'Generate Training Mission' based on the FPCON and % surge filled provided?			
FPCON	% surge filled	P(Success)	"+/-"
ALPHA(1)	100	0.96	0.03
ALPHA(1)	0	0.65	
DELTA(4)	0	0.7	

Undergraduate Flying Training			
What is the probability of Successfully completing 'Undergraduate Flying Training' based on the FPCON and % surge filled provided?			
FPCON	% surge filled	P(Success)	"+/-"
ALPHA(1)	100	0.98	0.03
ALPHA(1)	0	0.6	
DELTA(4)	0	0.5	

Mission Flying Training			
What is the probability of Successfully completing 'Mission Flying Training' based on the FPCON and % surge filled provided?			
FPCON	% surge filled	P(Success)	"+/-"
ALPHA(1)	100	0.99	0.03
ALPHA(1)	0	0.7	
DELTA(4)	0	0.6	

The inputs listed in the table 4.3 were used to approximate linear dependency relationships between all of the non-controlling and controlling nodes. The equations describing each of those relationships are presented below.

$$\text{Generate Training Mission} = 0.6333 + 0.0167(\text{FPCON}) + 0.31(\text{Percent Surge Filled})$$

$$\text{Obtain Training Material} = 0.9333 - 0.0833(\text{FPCON}) + 0.15(\text{Percent Surge Filled})$$

$$\text{UFT} = 0.633 - 0.0333(\text{FPCON}) + 0.38(\text{Percent Surge Filled})$$

$$\text{GFT} = 0.633 - 0.0333(\text{FPCON}) + 0.38(\text{Percent Surge Filled})$$

$$\text{MFT} = 0.733 - 0.0333(\text{FPCON}) + 0.29(\text{Percent Surge Filled})$$

$$\text{FDT} = 0.7833 - 0.0333(\text{FPCON}) + 0.24(\text{Percent Surge Filled})$$

The percent of the surge filled values computed above were combined with the FPCON levels to find the overall probability of success for the entire model. For this example, the equation to find the overall probability of success is the product of all non-controlling nodes with *Obtain Training Material* weighted to reflect how often it is activated. The resulting distribution reveals the most likely probability of success of the activities in this scenario is approximately 20% as presented in Figure 4.12.

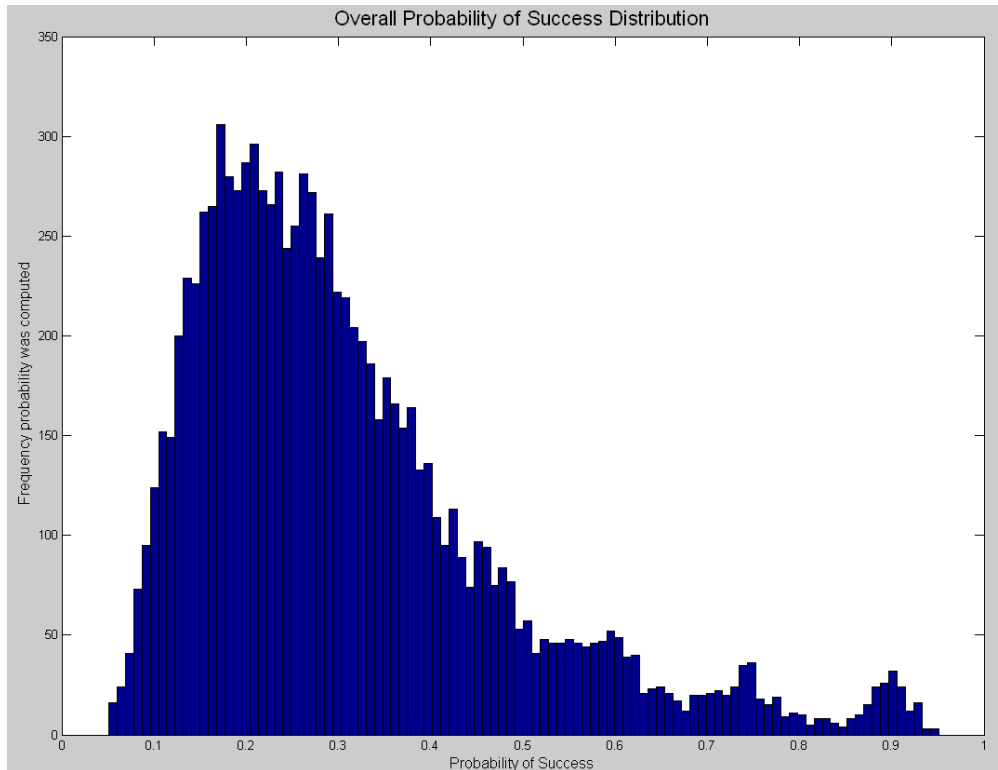

Figure 4.12 Overall Probability of Success Distribution

Next, a sensitivity analysis was conducted to determine the affect each node has on the outcome of the overall probability. The sensitivity analysis used was the availability method explained in Section 4.3. The result of the sensitivity analysis is shown in Figure 4.13. The node that has the most affect on the overall probability is the *Surge Required* Node followed by the *Ready Reserve* Node. For this example the node that was shown to most affect the overall probability turned out to be a node outside of the control of the Air Force. The surge required is largely dictated by the scenario. This does not suggest that it is not important to consider. Understanding what the leading drivers of the system are even when they are outside the control of the system lends itself to solutions that don't rely so strongly on that external factor. For example, if an analysis is conducted that shows the weather conditions are a significant factor in the successful

completion of the mission, it could point toward developing systems that can more reliability work in all weather situations.

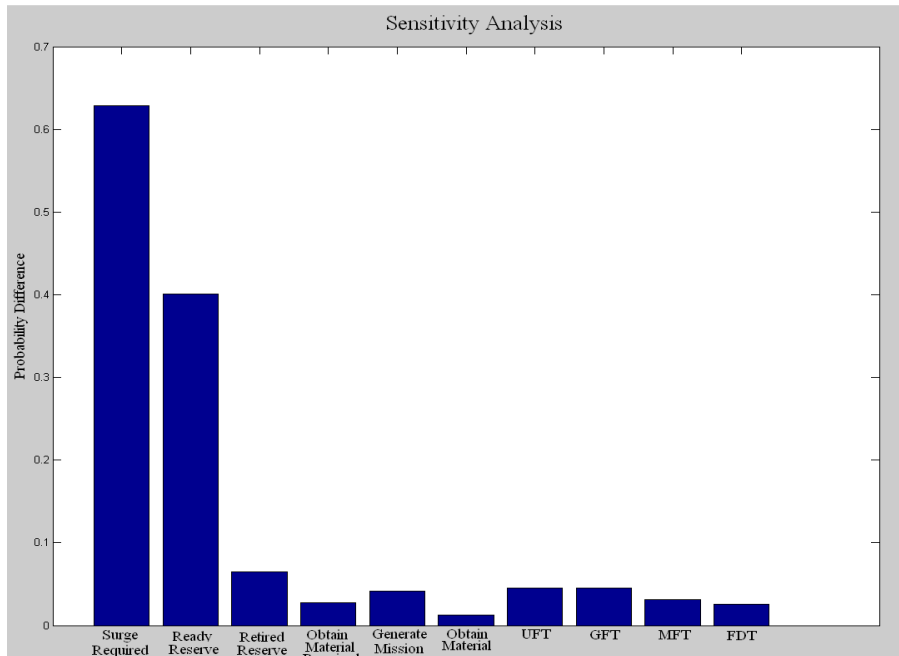

Figure 4.13 Sensitivity Analysis Results

5. Conclusion

5.1 Overview

The Air Force has established an analysis method for evaluating the capabilities it is expected to provide to the Joint-warfighter. It does this by combining the insights of Subject Matter Experts (SMEs) with a framework represented in Process Sequence Models (PSMs) to determine which capabilities cause the Air Force the greatest degree of risk. Ultimately, resource allocation decisions are made based on this evaluation. Over the last six years the Capability Review and Risk Assessment (CRRA) has gone through several iterations. Each iteration brought with it changes that were intended to uncover more information relevant to Air Force performance and increase the validity and repeatability of the process. The current CRRA method has come a long way since its inception but remains constrained by simplifying assumptions on the models that limit its insight into the problem under examination while creating avenues for critics to question the validity of its output. As this research pointed out, the most limiting assumptions made are:

- Each activity in a PSM can have only two states; success or failure.
- The degree by which an activity succeeds or fails has no impact on the overall mission completion.
- Each activity is evaluated assuming all other activities in the PSM were successful, thereby assuming independence in the scores.

Consequences of these assumptions are that the effect of capability quantity or sufficiency is not considered and there is no representation of dependencies or how dependencies can affect mission completion.

The method of Extended Sequence Modeling has been presented that relaxes these assumptions. ESMs allow CRRA practitioners to examine the dependent relationships of the system and discover how changes in dependent activities can ripple through a system to affect the overall outcome. Additionally, Air Force planners can now explore how the quantity of a capability or how well it is accomplished can impact mission success. It does this by empowering the CRRA practitioner with the ability to choose which dependencies are of interest to examine and which capabilities or activities are better modeled using a graduated scale of sufficiency rather than probability of success. It then uses input from SMEs to determine the strength of the dependency each of the dependent nodes have with their controlling nodes. This SME input combined with the techniques of reliability analysis and linear regression establishes linear relationships between the dependent and controlling nodes.

One of the strengths of this new method is it can be added to the existing PSMs. If the CRRA practitioner wishes to keep the current modeling technique intact but is still curious of a node's dependency on a particular controlling variable, the probability density function of that one node can be established using the techniques of ESMs while leaving the rest of the PSM unchanged. Additionally, ESMs can be used to stretch across traditional CONOPS lines. For example, the outcome of Agile Combat Support Activities can be linked to activities within operational CONOPS models. Therefore, when a sensitivity analysis is performed, it could result in evidence for the importance of the supporting functions. As is the case with all models, this new model also makes simplifying assumptions, albeit somewhat less restrictive ones than the current model. The most significant assumptions are that linear relationships exist between dependent

and controlling nodes and that all nodes not specifically shown to be dependent in the model are independent.

While this method was presented to show the minimum amount of information required from the SME, it was also shown that the method can be expanded. By accepting additional information from SMEs it is possible to arrive at a more accurate representation of the dependency relationships. Also, the expanded technique can avoid the potential for group think that can exist when a group of SMEs are forced to come to a consensus. This model formulation can easily fit a linear relationship to large numbers of SMEs, each contributing their own assessments of dependencies.

The Air Force is a large, complicated organization. Modeling its performance entails understanding its various components, how they interact with each other, to include the rules they follow and are constrained by, and how these factors change through time. It is exactly this sort of system that allows the benefits of Enterprise Architecture to be fully appreciated. To get the full benefits from architecture there are a few considerations that must be made. The first is the architecture should be able to contain all information that is relevant to the processes and people who use it. This does more than merely save people the hassle of jumping from one program to another to view all information they need. By having all information in one repository it allows relationships to be discovered and established which creates additional benefits, some of which were described in Chapter 4. Additionally, while architecture with a robust meta model to handle a wide variety of information types is essential, the presentation of that information needs to be adjustable. Many different people use architecture for different purposes. The user needs to be able to generate views, models, or other types of reports

that are in agreement with their purposes. In order to contain all of the required information it is likely the architecture itself would have to be maintained at a classified level. For example, for an Air Force Enterprise Architecture to fully support the CRRA, it would have to capture the scores provided by SMEs. These scores are classified and therefore the architecture would need to be classified.

The Air Force's Office of Warfighting Integration and Chief Information Officer (SAF/XC) has developed guidelines that allow architectures that are built throughout the Air Force to be "Fit for Federation". This means all architectures, whether they are for systems, organizations, or services can be interfaced with higher level architectures. Through these defined interfaces a user can start at a top level architecture and query, search, or explore down into all of the architectures that are federated to it. The power of this technique can be appreciated when viewed in application to the CRRA. Chapter 4 explored using an SV-5 and SV-7 to support the CRRA. Within a federated architecture, the architecture could be queried to produce an SV-5 and SV-7 of all systems or even organizations that provide a designated capability and the performance of that system.

With respect to the model used for the CRRA analysis, benefits of enterprise architecture can be seen in two overarching ways. The first is assisting the construction and scoring of the model to be evaluated. The Air Force architecture can contain information that can be reused for many different purposes including the CRRA. By pulling information from the architecture, models can be constructed that represent the parts of the Air Force to be studied by the CRRA. As already highlighted, the Draft DoDAF 2.0 contains new viewpoints that can be used to assist with the CRRA. The second benefit of enterprise architecture is its ability to capture the model used for the

evaluation and store it in the architecture to be used for future CRRA analysis or for other unforeseen purposes.







5.2 Recommendations for Future Research

The following items are suggested for further study.

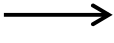
- 1) Once DoDAF version 2.0 becomes final, a thorough analysis should be conducted to understand how its expanded viewpoints and data model can assist the CRRA. Likewise, recommendations to add ESM to future DoDAF versions could begin.
- 2) Investigate a way to accurately assess the PAARs and implement a process to further research areas where additional risk may be accepted.
- 3) The CRRA is performed within each CONOP with limited connection between the CONOPs. Although the effects of a mission area in one CONOP on another CONOP is starting to be examined, there still exists disconnects. Research can be performed to determine how best to align the various missions under scrutiny within the CRRA. A study should be undertaken on how the ESM, and other techniques, can be used to combine the effects of multiple CONOPs. This concept could support the mathematical analysis of an integrated CRRA across CONOPs.
- 4) One concern from a CRRA practitioner was the lack of a technique to determine which shortfalls across the multiple CONOPS should be the highest priority. AF/A5X-C has started to address this issue. It would be beneficial to research a method for assessing shortfall priority across various CONOPs.

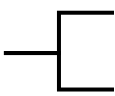
- 5) A study should examine the effects to opening up the CRRA to many more scoring SMEs for the purpose of getting more points of view.
- 6) This ESM approach uses linear relationships. The modeling of ESM dependencies using non-linear relationships could be examined.
- 7) Currently the final PSM result is a probability of success score that is related to a consequence by the combatant commands. It is a natural extension of this research to show how other variables other than probability of success can be linked to consequences. Through this, sufficiency of a capability can be linked to consequence similar to this research's aim to link sufficiency of a capability to probability of success.
- 8) Future work could study the statistical properties of the SME input data when finding the dependency relationships for the ESM method to determine if such information can be of use in the analysis. For example, the standard deviation of their scores might reveal information about the nature of dependent relationships or the uncertainty associated with those relationships.
- 9) Implementation of the ESM method should be demonstrated for distributions other than triangular. The behavior of normal distributions undergoing linear transformations is well understood (they remain normal), but other distributions may be necessary for cases where hard constraints bound possible values.

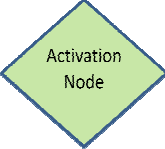
Appendix A. Icon Taxonomy

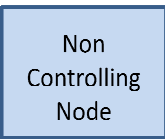
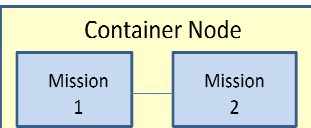
	Dependency Relationship	The pdf for the node at the head of the arrow is linearly dependent on the variable of the node at the tail of the arrow.
	Data Relationship	The value of the variable for the node at the tail of the arrow is input to the node at the head of the arrow – can only feed to a function node.
	Series Node Connector	Connects non-controlling nodes in series.
	Activation Relationship	Tail is always linked to activation node, head is always linked to a non-controlling node. It shows which non-controlling Node is activated by the Activation Node.
	Redundant Node Connector	Displays two or more nodes that are redundant
	Controlling Node	Can represent any activity or environmental factor that has a variable that will affect another node. Can be linked to a non-controlling or other controlling nodes by a Dependency Relationship or to a function by a data relationship. Variable can be P(s) or any other metric. They only affect overall mission P(s) indirectly through non-controlling nodes.
	Activation Node	Contains a percentage that controls the weighted strength of non-controlling nodes. Percentage usually dependent on the scenario.
	Function Node	Has a dependent variable that is determined by the input variable(s) and the function logic. * Must have one or more inputs * Output can be Data Relationship or Dependency Relationship
	Non-Controlling Node	Variable must be P(s). Directly impacts the P(s) of the overall mission.
	Container Node	Groups similar nodes.

Appendix B. MATLAB Code

```
%Written by Peter Mastro 28 January 2009
%Calculates overall probability of success for the sample model
presented
%to our thesis advisors on 27 January 2009, for the purpose of
validating
%the modeling method

clear %clears all variables
runs=10000; %sets the number of samples that will be taken of each
variable
disp('This program will calculate the overall probability of success of
the mission presented to the Advisors on Jan 27')

%The following block receives the bounds for the expected surge
requirement
%, builds the triangular distribution and picks random values from it
lowest_req=input('Enter the lowest expected surge requirement: ');
most_req=input('Enter the most likely surge requirement: ');
highest_req=input('Enter the highest likely surge requirement: ');

a = lowest_req;
b = highest_req;
c = most_req;
u = rand(runs,1); %selects random numbers
lo = (u<=((c-a)/(b-a))); %determines all random numbers that are less
than the mode
req(lo) = a + sqrt(u(lo).*((b-a)*(c-a))); %uses the inversion method
with the random numbers to generate triangular dist.
req(~lo) = b - sqrt((1-u(~lo)).*(b-a)*(b-c));
req=round(req);%rounds to the nearest whole number since we are dealing
with people
hist(req,((b-a)+1))%displays histogram that has the same number of bins
as there are number of different possible amounts
xlabel('Number of People Required for the Surge','FontSize',12)
ylabel('Frequency number was selected','FontSize',12)
title('Required Surge Distribution','FontSize',16)
disp(' ')

%The following block receives the bounds for the expected ready reserve
%, builds the triangular distribution and picks random values from it
lowest_redres=input('Enter the lower limit on expected Ready Reserve to
be recalled: ');
most_redres=input('Enter the most likely number of Ready Reserve to be
recalled: ');
highest_redres=input('Enter the upper limit on expected Ready Reserve
to be recalled: ');

a = lowest_redres;
b = highest_redres;
c = most_redres;
```

```

u = rand(runs,1);%selects random numbers
lo = (u<((c-a)/(b-a)));%determines all random numbers that are less
than the mode
redres(lo) = a + sqrt(u(lo).*((b-a)*(c-a)));%uses the inversion method
with the random numbers to generate triangular dist.
redres(~lo) = b - sqrt((1-u(~lo)).*(b-a)*(b-c));
redres=round(redres);%rounds to the nearest whole number since we are
dealing with people
hist(redres,((b-a)+1))%displays histogram that has the same number of
bins as there are number of different possible amounts
xlabel('Number of People received from the Ready
Reserve','FontSize',12)
ylabel('Frequency number was selected','FontSize',12)
title('Ready Reserve','FontSize',16)
disp(' ')

```

```

%The following block receives the bounds for the expected retired
reserve
%, builds the triangular distribution and picks random values from it
lowest_retres=input('Enter the lower limit on expected Retired Reserve
to be recalled: ');
most_retres=input('Enter the most likely number of Retired Reserve to
be recalled: ');
highest_retres=input('Enter the upper limit on expected Retired Reserve
to be recalled: ');

```

```

a = lowest_retres;
b = highest_retres;
c = most_retres;
u = rand(runs,1);%selects random numbers
lo = (u<((c-a)/(b-a)));%determines all random numbers that are less
than the mode
retres(lo) = a + sqrt(u(lo).*((b-a)*(c-a)));%uses the inversion method
with the random numbers to generate triangular dist.
retres(~lo) = b - sqrt((1-u(~lo)).*(b-a)*(b-c));
retres=round(retres);%rounds to the nearest whole number since we are
dealing with people
hist(retres,((b-a)+1))%displays histogram that has the same number of
bins as there are number of different possible amounts
xlabel('Number of People received from Retired Reserve','FontSize',12)
ylabel('Frequency number was selected','FontSize',12)
title('Retired Reserve','FontSize',16)
disp(' ')
result=input('press return when ready');

```

```

%The following block takes the random numbers previously generated and
%calculates the percent of the required surge that is met by the ready
and
%retired reserves, then displays a histogram of the information.
for n=1:runs
if (req(n)<=(redres(n)+retres(n)))
    percent_fill(n)=1; %if there are more people than required it
reports 100%
else

```

```

    percent_fill(n)= ((redres(n)+retres(n))/req(n));% if there are less
people than required this finds the percent filled
end
end
hist(percent_fill,100)% displays histogram
xlabel('Percent of the Surge Filled','FontSize',12) %label for
histogram
ylabel('Frequency percentage was computed','FontSize',12) %label for
histogram
title('Percent of Surge Filled','FontSize',16) %title for histogram
disp(' ')

%This receives the FPCON information then develops an array with the
same number of
%each level as inputted by the percentage inputted by the user
FPCON_Alpha=input('What is the probability the base will be at FPCON
Alpha? ');
FPCON_Bravo=input('What is the probability the base will be at FPCON
Bravo? ');
FPCON_Charlie=input('What is the probability the base will be at FPCON
Charlie? ');
FPCON_Delta=input('What is the probability the base will be at FPCON
Delta? ');

c=1;
for n=1:round(runs*FPCON_Alpha)
FPCON(c)=1; %fills an array to the appropriate percentage with 1 which
stands for Alpha
c=c+1;
end
for n=1:round(runs*FPCON_Bravo)
    c=c+1;
    FPCON(c)=2;%fills an array to the appropriate percentage with 2
which stands for Bravo
end
for n=1:round(runs*FPCON_Charlie)
    c=c+1;
    FPCON(c)=3;%fills an array to the appropriate percentage with 3
which stands for Charle
end
for n=1:round(runs*FPCON_Delta)
    c=c+1;
    FPCON(c)=4;%fills an array to the appropriate percentage with 4
which stands for Delta
end
hist(FPCON,100)% shows the histogram of the FPCONS
xlabel('FPCON levels','FontSize',12)%label for histogram
ylabel('Frequency level was selected','FontSize',12)%label for
histogram
title('FPCON level distribution','FontSize',16)
disp(' ')

%gets the probability obtain materials will be calculated in the final
%calculation

```

```

Acquire_mat=input('What is the probability additional training
materials will be required? ');

%The next block gets the probability of success for the non-controlling
%nodes from the user
if (lowest_req<(highest_redres+highest_retres))
greatest_percent_filled=1;
else

greatest_percent_filled=((highest_redres+highest_retres)/lowest_req);
end

if (highest_req<(lowest_redres+lowest_retres))
lowest_percent_filled=1;
else
lowest_percent_filled=((lowest_redres+lowest_retres)/highest_req);
end
disp(' ')
disp('For Generate Training Mission: ')
disp('If the FPCON is Alpha and the % surge filled is')
disp(greatest_percent_filled*100)
Gen_Miss(1)=input('what is the probability of success? ');
disp(' ')
disp('If the FPCON is Alpha and the % surge filled is')
disp(lowest_percent_filled*100)
Gen_Miss(2)=input('what is the probability of success? ');
disp(' ')
disp('If the FPCON is Delta and the % surge filled is')
disp(lowest_percent_filled*100)
Gen_Miss(3)=input('what is the probability of success? ');
GenMissRange=input('What is the "+/-" of the probability range? ');
%%%%%%%%%%%%%%%%%%%%%%%%%%%%%%%%%%%%%%%%%%%%%%%%%%%%%%%%%%%%%%%%%%%%%%%%
disp(' ')
disp('For Obtain Training Material: ')
disp('If the FPCON is Alpha and the % surge filled is')
disp(greatest_percent_filled*100)
ob_Mat(1)=input('what is the probability of success? ');
disp(' ')
disp('If the FPCON is Alpha and the % surge filled is')
disp(lowest_percent_filled*100)
ob_Mat(2)=input('what is the probability of success? ');
disp(' ')
disp('If the FPCON is Delta and the % surge filled is')
disp(lowest_percent_filled*100)
ob_Mat(3)=input('what is the probability of success? ');
obMatRange=input('What is the "+/-" of the probability range? ');
%%%%%%%%%%%%%%%%%%%%%%%%%%%%%%%%%%%%%%%%%%%%%%%%%%%%%%%%%%%%%%%%%%%%%%%%
disp(' ')
disp('For Undergraduate Flying Training: ')
disp('If the FPCON is Alpha and the % surge filled is')
disp(greatest_percent_filled*100)
UFT(1)=input('what is the probability of success? ');
disp(' ')
disp('If the FPCON is Alpha and the % surge filled is')
disp(lowest_percent_filled*100)

```

```

UFT(2)=input('what is the probability of success? ');
disp(' ')
disp('If the FPCON is Delta and the % surge filled is')
disp(lowest_percent_filled*100)
UFT(3)=input('what is the probability of success? ');
UFTRange=input('What is the "+/-" of the probability range? ');
%%%%%%%%%%%%%%%%%%%%%%%%%%%%%%%%%%%%%%%%%%%%%%%%%%%%%%%%%%%%%%%%%%%%%%%%
disp(' ')
disp('For Graduate Flying Training: ')
disp('If the FPCON is Alpha and the % surge filled is')
disp(greatest_percent_filled*100)
GFT(1)=input('what is the probability of success? ');

disp('If the FPCON is Alpha and the % surge filled is')
disp(lowest_percent_filled*100)
GFT(2)=input('what is the probability of success? ');

disp('If the FPCON is Delta and the % surge filled is')
disp(lowest_percent_filled*100)
GFT(3)=input('what is the probability of success? ');
GFTRange=input('What is the "+/-" of the probability range? ');
%%%%%%%%%%%%%%%%%%%%%%%%%%%%%%%%%%%%%%%%%%%%%%%%%%%%%%%%%%%%%%%%%%%%%%%%
disp(' ')
disp('For Mission Flying Training: ')
disp('If the FPCON is Alpha and the % surge filled is' )
disp(greatest_percent_filled*100)
MFT(1)=input('what is the probability of success? ');
disp(' ')
disp('If the FPCON is Alpha and the % surge filled is' )
disp(lowest_percent_filled*100)
MFT(2)=input('what is the probability of success? ');
disp(' ')
disp('If the FPCON is Delta and the % surge filled is' )
disp(lowest_percent_filled*100)
MFT(3)=input('what is the probability of success? ');
MFTRange=input('What is the "+/-" of the probability range? ');
%%%%%%%%%%%%%%%%%%%%%%%%%%%%%%%%%%%%%%%%%%%%%%%%%%%%%%%%%%%%%%%%%%%%%%%%
disp(' ')
disp('For Flying Deployment Training: ')
disp('If the FPCON is Alpha and the % surge filled is')
disp(greatest_percent_filled*100)
FDT(1)=input('what is the probability of success? ');
disp(' ')
disp('If the FPCON is Alpha and the % surge filled is')
disp(lowest_percent_filled*100)
FDT(2)=input('what is the probability of success? ');
disp(' ')
disp('If the FPCON is Delta and the % surge filled is')
disp(lowest_percent_filled*100)
FDT(3)=input('what is the probability of success? ');
FDTRange=input('What is the "+/-" of the probability range? ');
%%%%%%%%%%%%%%%%%%%%%%%%%%%%%%%%%%%%%%%%%%%%%%%%%%%%%%%%%%%%%%%%%%%%%%%%

%The next block finds the parameters of the dependency equation for
each of

```

```

%the non-controlling nodes
x=[1,1,greatest_percent_filled;1,1,lowest_percent_filled;1,4,lowest_per
cent_filled];%builds the input variable matrix

y=Gen_Miss';
GenMissB=((x'*x)^-1)*(x'*y);

y=ob_Mat';
ob_MatB=((x'*x)^-1)*(x'*y);

y=UFT';
UFTB=((x'*x)^-1)*(x'*y);

y=GFT';
GFTB=((x'*x)^-1)*(x'*y);

y=MFT';
MFTB=((x'*x)^-1)*(x'*y);

y=FDT';
FDTB=((x'*x)^-1)*(x'*y);

%This finds the mode of the pdf for each of the runs for each of
%the non-controlling nodes
for n=1:runs
GenMissProbmode(n)=GenMissB(1)+GenMissB(2)*FPCON(n)+GenMissB(3)*percent
_fill(n);
end

for n=1:runs
obMatProbmode(n)=ob_MatB(1)+ob_MatB(2)*FPCON(n)+ob_MatB(3)*percent_fill
(n);
end

for n=1:runs
UFTProbmode(n)=UFTB(1)+UFTB(2)*FPCON(n)+UFTB(3)*percent_fill(n);
end

for n=1:runs
GFTProbmode(n)=GFTB(1)+GFTB(2)*FPCON(n)+GFTB(3)*percent_fill(n);
end

for n=1:runs
MFTProbmode(n)=MFTB(1)+MFTB(2)*FPCON(n)+MFTB(3)*percent_fill(n);
end

for n=1:runs
FDTProbmode(n)=FDTB(1)+FDTB(2)*FPCON(n)+FDTB(3)*percent_fill(n);
end

```



```

%The next block generates triangular distributions based on the modes
generated above then picks a random number from the
%distribution
a = GenMissProbmode-GenMissRange;
b = GenMissProbmode+GenMissRange;
c = GenMissProbmode;
u = rand(runs,1); %selects random number
for n=1:runs
if (u(n)<((c(n)-a(n))/(b(n)-a(n))));
GenMissProb(n)= a(n) + sqrt(u(n)*((b(n)-a(n))*(c(n)-a(n))));
if GenMissProb(n)>1
GenMissProb(n)=1; %if because of the Range the probability is
greater than 1 it is assigned 1
end
if GenMissProb(n)<0
GenMissProb(n)=0; %if because of the Range the probability is less
than 0 it is assigned 0
end
else
GenMissProb(n) = b(n) - sqrt((1-u(n))*(b(n)-a(n))*(b(n)-c(n)));
if GenMissProb(n)>1
GenMissProb(n)=1;%if because of the Range the probability is
greater than 1 it is assigned 1
end
if GenMissProb(n)<0
GenMissProb(n)=0;%if because of the Range the probability is less
than 0 it is assigned 0
end
end
end
%%%%%%%%%%%%%%%%%%%%%%%%%%%%%%%%%%%%%%%%%%%%%%%%%%%%%%%%%%%%%%%%%%%%%%%%
a = obMatProbmode-obMatRange;
b = obMatProbmode+obMatRange;
c = obMatProbmode;
u = rand(runs,1);%selects random numbers
for n=1:runs
if (u(n)<((c(n)-a(n))/(b(n)-a(n))));
obMatProb(n)= a(n) + sqrt(u(n)*((b(n)-a(n))*(c(n)-a(n))));
if obMatProb(n)>1
obMatProb(n)=1;%if because of the Range the probability is greater
than 1 it is assigned 1
end
if obMatProb(n)<0
obMatProb(n)=0;%if because of the Range the probability is less
than 0 it is assigned 0
end
else
obMatProb(n) = b(n) - sqrt((1-u(n))*(b(n)-a(n))*(b(n)-c(n)));
if obMatProb(n)>1
obMatProb(n)=1;%if because of the Range the probability is greater
than 1 it is assigned 1
end
if obMatProb(n)<0
obMatProb(n)=0;%if because of the Range the probability is less
than 0 it is assigned 0

```

```

end
end
end
%%%%%%%%%%%%%%%%%%%%%%%%%%%%%%%%%%%%%%%%%%%%%%%%%%%%%%%%%%%%%%%%%%%%%%%%
a = UFTProbmode-UFTRange;
b = UFTProbmode+UFTRange;
c = UFTProbmode;
u = rand(runs,1);%selects random numbers
for n=1:runs
if (u(n)<((c(n)-a(n))/(b(n)-a(n))));
UFTProb(n)= a(n) + sqrt(u(n)*((b(n)-a(n))*(c(n)-a(n))));
if UFTProb(n)>1
    UFTProb(n)=1;%if because of the Range the probability is greater
than 1 it is assigned 1
end
if UFTProb(n)<0
    UFTProb(n)=0;%if because of the Range the probability is less than
0 it is assigned 0
end
else
UFTProb(n) = b(n) - sqrt((1-u(n))*(b(n)-a(n))*(b(n)-c(n)));
if UFTProb(n)>1
    UFTProb(n)=1;%if because of the Range the probability is greater
than 1 it is assigned 1
end
if UFTProb(n)<0
    UFTProb(n)=0;%if because of the Range teh probability is less than
0 it is assigned 0
end
end
end
%%%%%%%%%%%%%%%%%%%%%%%%%%%%%%%%%%%%%%%%%%%%%%%%%%%%%%%%%%%%%%%%%%%%%%%%
a = GFTProbmode-GFTRange;
b = GFTProbmode+GFTRange;
c = GFTProbmode;
u = rand(runs,1);%selects random numbers
for n=1:runs
if (u(n)<((c(n)-a(n))/(b(n)-a(n))));
GFTProb(n)= a(n) + sqrt(u(n)*((b(n)-a(n))*(c(n)-a(n))));
if GFTProb(n)>1
    GFTProb(n)=1;%if because of the Range the probability is greater
than 1 it is assigned 1
end
if GFTProb(n)<0
    GFTProb(n)=0;%if because of the Range the probability is less than
0 it is assigned 0
end
else
GFTProb(n) = b(n) - sqrt((1-u(n))*(b(n)-a(n))*(b(n)-c(n)));
if GFTProb(n)>1
    GFTProb(n)=1;%if because of the Range the probability is greater
than 1 it is assigned 1
end
if GFTProb(n)<0

```

```

    GFTProb(n)=0;%if because of the Range the probability is less than
0 it is assigned 0
end
end
end
%%%%%%%%%%%%%%%%%%%%%%%%%%%%%%%%%%%%%%%%%%%%%%%%%%%%%%%%%%%%%%%%%%%%%%%%
a = MFTProbmode-MFTRange;
b = MFTProbmode+MFTRange;
c = MFTProbmode;
u = rand(runs,1);%selects random numbers
for n=1:runs
if (u(n)<((c(n)-a(n))/(b(n)-a(n))));
MFTProb(n)= a(n) + sqrt(u(n)*((b(n)-a(n))*(c(n)-a(n))));
if MFTProb(n)>1
    MFTProb(n)=1;%if because of the Range the probability is greater
than 1 it is assigned 1
end
if MFTProb(n)<0
    MFTProb(n)=0;%if because of the Range the probability is less than
0 it is assigned 0
end
else
MFTProb(n) = b(n) - sqrt((1-u(n))*(b(n)-a(n))*(b(n)-c(n)));
if MFTProb(n)>1
    MFTProb(n)=1;%if because of the Range the probability is greater
than 1 it is assigned 1
end
if MFTProb(n)<0
    MFTProb(n)=0;%if because of the Range the probability is less than
0 it is assigned 0
end
end
end
%%%%%%%%%%%%%%%%%%%%%%%%%%%%%%%%%%%%%%%%%%%%%%%%%%%%%%%%%%%%%%%%%%%%%%%%
a = FDTProbmode-FDTRange;
b = FDTProbmode+FDTRange;
c = FDTProbmode;
u = rand(runs,1);%selects random numbers
for n=1:runs
if (u(n)<((c(n)-a(n))/(b(n)-a(n))));
FDTProb(n)= a(n) + sqrt(u(n)*((b(n)-a(n))*(c(n)-a(n))));
if FDTProb(n)>1
    FDTProb(n)=1;%if because of the Range the probability is greater
than 1 it is assigned 1
end
if FDTProb(n)<0
    FDTProb(n)=0;%if because of the Range the probability is less than
0 it is assigned 0
end
else
FDTProb(n) = b(n) - sqrt((1-u(n))*(b(n)-a(n))*(b(n)-c(n)));
if FDTProb(n)>1
    FDTProb(n)=1;%if because of the Range the probability is greater
than 1 it is assigned 1
end
end

```

```

if FDTProb(n)<0
    FDTProb(n)=0;%if because of the Range the probability is less than
0 it is assigned 0
end
end
end

%This next block takes all of the probabilities found in the last
section
%and multiplies them to find the overall probability
for n=1:runs
    totalprob(n)=GenMissProb(n)*((obMatProb(n)*Acquire_mat)+(1-
Acquire_mat))*UFTProb(n)*GFTProb(n)*MFTProb(n)*FDTProb(n);
end
hist(totalprob,100)%displays the final probability
xlabel('Probability of Success','FontSize',12)%label for histogram
ylabel('Frequency probability was computed','FontSize',12)%label for
histogram
title('Overall Probability of Success
Distribution','FontSize',16)%title for histogram
%Written by Peter Mastro 30 January 2009
%This program finds the sensitivity of the overall probability to
changes
%in each of the nodes
SurgReq=lowest_req; %sets the surge required to the lowest value it can
take on
ReadyRes=most_redres;
RetiredRes=most_retres;

%Finds the percent surge filled
if (SurgReq<=(ReadyRes+RetiredRes))
    filled=1;
else
    filled=(ReadyRes+RetiredRes)/SurgReq;
end

ForceProt=1;

GenMissionSens=GenMissB(1)+GenMissB(2)*ForceProt+GenMissB(3)*filled;
ObtainMatSens=ob_MatB(1)+ob_MatB(2)*ForceProt+ob_MatB(3)*filled;
UFTSens=UFTB(1)+UFTB(2)*ForceProt+UFTB(3)*filled;
GFTSens=GFTB(1)+GFTB(2)*ForceProt+GFTB(3)*filled;
MFTSens=MFTB(1)+MFTB(2)*ForceProt+MFTB(3)*filled;
FDTsens=FDTB(1)+FDTB(2)*ForceProt+FDTB(3)*filled;
SurgeLowtotal=GenMissionSens*((Acquire_mat*ObtainMatSens)+(1-
Acquire_mat))*UFTSens*GFTSens*MFTSens*FDTsens; %Finds the overall
probability based on the lowest surge required
disp('The overall probability of success when the Surge is at its
lowest is')
disp(SurgeLowtotal)

%%%%%%%%%%%%%%

SurgReq=highest_req;%sets surge required to the most it can be

```

```

ReadyRes=most_redres;
RetiredRes=most_retres;

%calculates percent surge filled
if (SurgReq<=(ReadyRes+RetiredRes))
    filled=1;
else
    filled=(ReadyRes+RetiredRes)/SurgReq;
end

ForceProt=1;

GenMissionSens=GenMissB(1)+GenMissB(2)*ForceProt+GenMissB(3)*filled;
ObtainMatSens=ob_MatB(1)+ob_MatB(2)*ForceProt+ob_MatB(3)*filled;
UFTSens=UFTB(1)+UFTB(2)*ForceProt+UFTB(3)*filled;
GFTSens=GFTB(1)+GFTB(2)*ForceProt+GFTB(3)*filled;
MFTSens=MFTB(1)+MFTB(2)*ForceProt+MFTB(3)*filled;
FDTsens=FDTB(1)+FDTB(2)*ForceProt+FDTB(3)*filled;
SurgeHighttotal=GenMissionSens*((Acquire_mat*ObtainMatSens)+(1-
Acquire_mat))*UFTSens*GFTSens*MFTSens*FDTsens; %finds overall
probability based on the highest surge value
disp('The overall probability of success when the Surge is at its
highest is')
disp(SurgeHighttotal)
SurgeSensdiff=abs(SurgeHighttotal-SurgeLowtotal);%computes the
difference between the two extremes of the surge
disp('The probability difference is')
disp(SurgeSensdiff)
%%%%%%%%%%%%%%

SurgReq=most_req;
ReadyRes=lowest_redres; %sets the Ready Reserve to the lowest value it
can attain
RetiredRes=most_retres;

%Finds the percent surge filled
if (SurgReq<=(ReadyRes+RetiredRes))
    filled=1;
else
    filled=(ReadyRes+RetiredRes)/SurgReq;
end

ForceProt=1;

GenMissionSens=GenMissB(1)+GenMissB(2)*ForceProt+GenMissB(3)*filled;
ObtainMatSens=ob_MatB(1)+ob_MatB(2)*ForceProt+ob_MatB(3)*filled;
UFTSens=UFTB(1)+UFTB(2)*ForceProt+UFTB(3)*filled;
GFTSens=GFTB(1)+GFTB(2)*ForceProt+GFTB(3)*filled;
MFTSens=MFTB(1)+MFTB(2)*ForceProt+MFTB(3)*filled;
FDTsens=FDTB(1)+FDTB(2)*ForceProt+FDTB(3)*filled;
ReadyLowtotal=GenMissionSens*((Acquire_mat*ObtainMatSens)+(1-
Acquire_mat))*UFTSens*GFTSens*MFTSens*FDTsens; %calculates the overall
probability based on the low Ready Reserve number

```

```

disp('The overall probability of success when the Ready Reserve is at
its lowest is')
disp(ReadyLowtotal)

%%%%%%%%%%

SurgReq=most_req;
ReadyRes=highest_redres;
RetiredRes=most_retres;

%Finds the percent surge filled
if (SurgReq<=(ReadyRes+RetiredRes))
    filled=1;
else
    filled=(ReadyRes+RetiredRes)/SurgReq;
end

ForceProt=1;

GenMissionSens=GenMissB(1)+GenMissB(2)*ForceProt+GenMissB(3)*filled;
ObtainMatSens=ob_MatB(1)+ob_MatB(2)*ForceProt+ob_MatB(3)*filled;
UFTSens=UFTB(1)+UFTB(2)*ForceProt+UFTB(3)*filled;
GFTSens=GFTB(1)+GFTB(2)*ForceProt+GFTB(3)*filled;
MFTSens=MFTB(1)+MFTB(2)*ForceProt+MFTB(3)*filled;
FDTsens=FDTB(1)+FDTB(2)*ForceProt+FDTB(3)*filled;
ReadyHighttotal=GenMissionSens*((Acquire_mat*ObtainMatSens)+(1-
Acquire_mat))*UFTSens*GFTSens*MFTSens*FDTsens;%calculates the overall
probability based on the high Ready Reserve number
disp('The overall probability of success when the Ready Reserve is at
its highest is')
disp(ReadyHighttotal)
ReadySensdiff=abs(ReadyHighttotal-ReadyLowtotal);%computes the
difference between the two extremes of the Ready Reserve
disp('The probability difference is')
disp(ReadySensdiff)
%%%%%%%%%%

SurgReq=most_req;
ReadyRes=most_redres;
RetiredRes=lowest_retres;%Sets the Retired Reserve to the lowest it
can attain

%Finds the percent surge filled
if (SurgReq<=(ReadyRes+RetiredRes))
    filled=1;
else
    filled=(ReadyRes+RetiredRes)/SurgReq;
end

ForceProt=1;

GenMissionSens=GenMissB(1)+GenMissB(2)*ForceProt+GenMissB(3)*filled;
ObtainMatSens=ob_MatB(1)+ob_MatB(2)*ForceProt+ob_MatB(3)*filled;

```

```

UFTSens=UFTB(1)+UFTB(2)*ForceProt+UFTB(3)*filled;
GFTSens=GFTB(1)+GFTB(2)*ForceProt+GFTB(3)*filled;
MFTSens=MFTB(1)+MFTB(2)*ForceProt+MFTB(3)*filled;
FDTsens=FDTB(1)+FDTB(2)*ForceProt+FDTB(3)*filled;
RetiredLowtotal=GenMissionSens*((Acquire_mat*ObtainMatSens)+(1-
Acquire_mat))*UFTSens*GFTSens*MFTSens*FDTsens;
disp('The overall probability of success when the Retired Reserve is at
its lowest is')
disp(RetiredLowtotal)

```

```

%%%%%%%%%%%%%%%%%%%%%%%%%%%%%%%%%%%%%%%%%%%%%%%%%%%%%%%%%%%%%%%%%%%%%%%%

```

```

SurgReq=most_req;
ReadyRes=most_redres;
RetiredRes=highest_retres;%sets the Retired Reserve to the highest it
can attain

```

```

%Finds the percent surge filled
if (SurgReq<=(ReadyRes+RetiredRes))
    filled=1;
else
    filled=(ReadyRes+RetiredRes)/SurgReq;
end

```

```

ForceProt=1;

```

```

GenMissionSens=GenMissB(1)+GenMissB(2)*ForceProt+GenMissB(3)*filled;
ObtainMatSens=ob_MatB(1)+ob_MatB(2)*ForceProt+ob_MatB(3)*filled;
UFTSens=UFTB(1)+UFTB(2)*ForceProt+UFTB(3)*filled;
GFTSens=GFTB(1)+GFTB(2)*ForceProt+GFTB(3)*filled;
MFTSens=MFTB(1)+MFTB(2)*ForceProt+MFTB(3)*filled;
FDTsens=FDTB(1)+FDTB(2)*ForceProt+FDTB(3)*filled;
RetiredHighttotal=GenMissionSens*((Acquire_mat*ObtainMatSens)+(1-
Acquire_mat))*UFTSens*GFTSens*MFTSens*FDTsens;
disp('The overall probability of success when the Retired Reserve is at
its highest is')
disp(RetiredHighttotal)

```

```

RetiredSensdiff=abs(RetiredHighttotal-RetiredLowtotal);%computes the
difference between the two extremes of the Retired Reserve

```

```

disp('The probability difference is')

```

```

disp(RetiredSensdiff)

```

```

%%%%%%%%%%%%%%%%%%%%%%%%%%%%%%%%%%%%%%%%%%%%%%%%%%%%%%%%%%%%%%%%%%%%%%%%

```

```

%These next blocks determine the effect that the Force Protection has
SurgReq=most_req;
ReadyRes=most_redres;
RetiredRes=most_retres;

```

```

%Finds the percent surge filled
if (SurgReq<=(ReadyRes+RetiredRes))
    filled=1;
else
    filled=(ReadyRes+RetiredRes)/SurgReq;
end

```

```

ForceProt=1;

GenMissionSens=GenMissB(1)+GenMissB(2)*ForceProt+GenMissB(3)*filled;
ObtainMatSens=ob_MatB(1)+ob_MatB(2)*ForceProt+ob_MatB(3)*filled;
UFTSens=UFTB(1)+UFTB(2)*ForceProt+UFTB(3)*filled;
GFTSens=GFTB(1)+GFTB(2)*ForceProt+GFTB(3)*filled;
MFTSens=MFTB(1)+MFTB(2)*ForceProt+MFTB(3)*filled;
FDTsens=FDTB(1)+FDTB(2)*ForceProt+FDTB(3)*filled;
FPCONLow=GenMissionSens*((Acquire_mat*ObtainMatSens)+(1-
Acquire_mat))*UFTSens*GFTSens*MFTSens*FDTsens; %Finds the overall
probability based on FPCON Alpha
disp('The overall probability of success when the FPCON is Alpha is')
disp(FPCONLow)

%%%%%%%%%%%%

SurgReq=most_req;%sets surge required to the most it can be
ReadyRes=most_redres;
RetiredRes=most_retres;

%calculates percent surge filled
if (SurgReq<=(ReadyRes+RetiredRes))
    filled=1;
else
    filled=(ReadyRes+RetiredRes)/SurgReq;
end

ForceProt=4;

GenMissionSens=GenMissB(1)+GenMissB(2)*ForceProt+GenMissB(3)*filled;
ObtainMatSens=ob_MatB(1)+ob_MatB(2)*ForceProt+ob_MatB(3)*filled;
UFTSens=UFTB(1)+UFTB(2)*ForceProt+UFTB(3)*filled;
GFTSens=GFTB(1)+GFTB(2)*ForceProt+GFTB(3)*filled;
MFTSens=MFTB(1)+MFTB(2)*ForceProt+MFTB(3)*filled;
FDTsens=FDTB(1)+FDTB(2)*ForceProt+FDTB(3)*filled;
FPCONHigh=GenMissionSens*((Acquire_mat*ObtainMatSens)+(1-
Acquire_mat))*UFTSens*GFTSens*MFTSens*FDTsens; %finds overall
probability based on the highest surge value
disp('The overall probability of success when the FPCON is Delta is')
disp(FPCONHigh)
FPCONdiff=abs(FPCONLow-FPCONHigh);%computes the difference between the
two extremes of the FPCON
disp('The probability difference is')
disp(FPCONdiff)
%%%%%%%%%%%%
%The next two blocks turn "on" and "off" the obtain Material node to
determine
%the effect of having it on and off
SurgReq=most_req;
ReadyRes=most_redres;
RetiredRes=most_retres;

%Finds the percent surge filled
if (SurgReq<=(ReadyRes+RetiredRes))

```



```

        filled=1;
else
    filled=(ReadyRes+RetiredRes)/SurgReq;
end

ForceProt=1;

GenMissionSens=GenMissB(1)+GenMissB(2)*ForceProt+GenMissB(3)*filled;
ObtainMatSens=ob_MatB(1)+ob_MatB(2)*ForceProt+ob_MatB(3)*filled;
UFTSens=UFTB(1)+UFTB(2)*ForceProt+UFTB(3)*filled;
GFTSens=GFTB(1)+GFTB(2)*ForceProt+GFTB(3)*filled;
MFTSens=MFTB(1)+MFTB(2)*ForceProt+MFTB(3)*filled;
FDTsens=FDTB(1)+FDTB(2)*ForceProt+FDTB(3)*filled;
AcqMatttotal=GenMissionSens*ObtainMatSens*UFTSens*GFTSens*MFTSens*FDTsens;%finds overall probability based on needing to accomplish the obtain
Material node
disp('The overall probability of success when it is required to Acquire
Material is')
disp(AcqMatttotal)

%%%%%%%%%%%%%%%%%%%%%%%%%%%%%%%%%%%%%%%%%%%%%%%%%%%%%%%%%%%%%%%%%%%%%%%%

SurgReq=most_req;
ReadyRes=most_redres;
RetiredRes=most_retres;

%Finds the percent surge filled
if (SurgReq<=(ReadyRes+RetiredRes))
    filled=1;
else
    filled=(ReadyRes+RetiredRes)/SurgReq;
end

ForceProt=1;

GenMissionSens=GenMissB(1)+GenMissB(2)*ForceProt+GenMissB(3)*filled;
ObtainMatSens=ob_MatB(1)+ob_MatB(2)*ForceProt+ob_MatB(3)*filled;
UFTSens=UFTB(1)+UFTB(2)*ForceProt+UFTB(3)*filled;
GFTSens=GFTB(1)+GFTB(2)*ForceProt+GFTB(3)*filled;
MFTSens=MFTB(1)+MFTB(2)*ForceProt+MFTB(3)*filled;
FDTsens=FDTB(1)+FDTB(2)*ForceProt+FDTB(3)*filled;
NotAcqMatttotal=GenMissionSens*UFTSens*GFTSens*MFTSens*FDTsens;%finds
overall probability based on not needing to accomplish the obtain
Material node
disp('The overall probability of success when not required to Acquire
Material is')
disp(NotAcqMatttotal)
AcqMatsensdiff=abs(NotAcqMatttotal-AcqMatttotal);%computes the difference
between needing to obtain materials and not needing to
disp('The probability difference is')
disp(AcqMatsensdiff)
%%%%%%%%%%%%%%%%%%%%%%%%%%%%%%%%%%%%%%%%%%%%%%%%%%%%%%%%%%%%%%%%%%%%%%%%

```

```

%%%%%%%%%%%%%%%%%%%%%%%%%%%%%%%%%%%%%%%%%%%%%%%%%%%%%%%%%%%%%%%%%%%%%%%%
SurgReq=most_req;
ReadyRes=most_redres;
RetiredRes=most_retres;

%Finds the percent surge filled
if (SurgReq<=(ReadyRes+RetiredRes))
    filled=1;
else
    filled=(ReadyRes+RetiredRes)/SurgReq;
end

ForceProt=1;

%The following block finds the overall probability of success when each
node takes
%on its mode value and the overall probability of success when each
node takes on
%the value half way between its mode and 1. Only one node is moved at
a
%time to see its affect on the overall probability of success.
GenMissionSens=GenMissB(1)+GenMissB(2)*ForceProt+GenMissB(3)*filled;
GenMissionSensHigh=(1-GenMissionSens)/2+GenMissionSens;
ObtainMatSens=ob_MatB(1)+ob_MatB(2)*ForceProt+ob_MatB(3)*filled;
ObtainMatSensHigh=(1-ObtainMatSens)/2+ObtainMatSens;
UFTSens=UFTB(1)+UFTB(2)*ForceProt+UFTB(3)*filled;
UFTSensHigh=(1-UFTSens)/2+UFTSens;
GFTSens=GFTB(1)+GFTB(2)*ForceProt+GFTB(3)*filled;
GFTSensHigh=(1-GFTSens)/2+GFTSens;
MFTSens=MFTB(1)+MFTB(2)*ForceProt+MFTB(3)*filled;
MFTSensHigh=(1-MFTSens)/2+MFTSens;
FDTsSens=FDTB(1)+FDTB(2)*ForceProt+FDTB(3)*filled;
FDTsSensHigh=(1-FDTsSens)/2+FDTsSens;

%This block finds the difference between the two probability of success
found for each node above to determine the impact each node has on
%the overall probability of success.
GenMissiondiff=((Acquire_mat*ObtainMatSens)+(1-
Acquire_mat))*UFTSens*GFTSens*MFTSens*FDTsSens*(GenMissionSensHigh-
GenMissionSens);
ObtainMatdiff=GenMissionSens*UFTSens*GFTSens*MFTSens*FDTsSens*((Acquire_
mat*ObtainMatSensHigh+(1-Acquire_mat))-(Acquire_mat*ObtainMatSens+(1-
Acquire_mat)));
UFTdiff=((Acquire_mat*ObtainMatSens)+(1-
Acquire_mat))*GFTSens*MFTSens*FDTsSens*GenMissionSens*(UFTSensHigh-
UFTSens);
GFTdiff=((Acquire_mat*ObtainMatSens)+(1-
Acquire_mat))*MFTSens*FDTsSens*GenMissionSens*UFTSens*(GFTSensHigh-
GFTSens);
MFTdiff=((Acquire_mat*ObtainMatSens)+(1-
Acquire_mat))*FDTsSens*GenMissionSens*UFTSens*GFTSens*(MFTSensHigh-
MFTSens);

```

```

FDTdiff=((Acquire_mat*ObtainMatSens)+(1-
Acquire_mat))*GenMissionSens*UFTSens*GFTSens*MFTSens*(FDTSENSHigh-
FDTSENS);

disp('The probability difference for Generate the Mission is')
disp(GenMissiondiff)
disp('The probability difference for Obtain Materials is')
disp(ObtainMatdiff)
disp('The probability difference for Undergraduate Flying Training is')
disp(UFTdiff)
disp('The probability difference for Graduate Flying Training is')
disp(GFTdiff)
disp('The probability difference for Mission Flying Training is')
disp(MFTdiff)
disp('The probability difference for Flying Deployment Training is')
disp(FDTdiff)

%Displays the results to a bar graph so the user can see which node is
most
%controlling.
sensmatrix=[SurgeSensdiff,ReadySensdiff,RetiredSensdiff,FPCONdiff,AcqMa
tsensdiff,GenMissiondiff,ObtainMatdiff,UFTdiff,GFTdiff,MFTdiff,FDTdiff]
;
x=[1,2,3,4,5,6,7,8,9,10,11];
bar(x,sensmatrix)

```

Appendix C. Example Data Input

Identify Surge Requirements	
Given the scenario what is the lowest likely number of surge personnel required?	20
Given the scenario what is the most likely number of surge personnel required?	60
Given the scenario what is the largest likely number of surge personnel required?	80

Recall Ready Reserve	
Given the scenario, what is the lower limit on the expected number of Ready Reserve the can be recalled?	0
Given the scenario, what is the expected number of Ready Reserve the can be recalled?	30
Given the scenario, what is the upper limit on the expected number of Ready Reserve the can be recalled?	40

Recall Standby/Retired Reserve	
Given the scenario, what is the lower limit on the expected number of Standby/Retired Reserve the can be recalled?	0
Given the scenario, what is the expected number of Standby/Retired Reserve the can be recalled?	2
Given the scenario, what is the upper limit on the expected number of Standby/Retired Reserve the can be recalled?	5

Force Protection Condition	
Given the scenario what is the probability the base is at FPCON ALPHA(1)?	0.40
Given the scenario what is the probability the base is at FPCON BRAVO(2)?	0.30

Given the scenario what is the probability the base is at FPCON CHARLIE(3)?	0.20
Given the scenario what is the probability the base is at FPCON DELTA(4)?	0.10
Sum must equal 1.00:	1.00

Acquire Materiel?	
Given the scenario, how likely is it that additional training materials will be required?	0.90

Generate Training Mission			
What is the probability of Successfully completing 'Generate Training Mission' based on the FPCON and % surge filled provided?			
FPCON	% surge filled	P(Success)	" +/- "
ALPHA(1)	100	0.96	0.03
ALPHA(1)	0	0.65	
DELTA(4)	0	0.7	

Obtain Training Material			
What is the probability of Successfully completing 'Obtain Training Material' based on the FPCON and % surge filled provided?			
FPCON	% surge filled	P(Success)	" +/- "
ALPHA(1)	100	1	0.03
ALPHA(1)	0	0.85	
DELTA(4)	0	0.6	

Undergraduate Flying Training			
What is the probability of Successfully completing 'Undergraduate Flying Training' based on the FPCON and % surge filled provided?			
FPCON	% surge filled	P(Success)	" +/- "
ALPHA(1)	100	0.98	0.03
ALPHA(1)	0	0.6	
DELTA(4)	0	0.5	

Graduate Flying Training			
What is the probability of Successfully completing 'Graduate Flying Training' based on the FPCON and % surge filled provided?			
FPCON	% surge filled	P(Success)	"+/-"
ALPHA(1)	100	0.98	0.03
ALPHA(1)	0	0.6	
DELTA(4)	0	0.5	

Mission Flying Training			
What is the probability of Successfully completing 'Mission Flying Training' based on the FPCON and % surge filled provided?			
FPCON	% surge filled	P(Success)	"+/-"
ALPHA(1)	100	0.99	0.03
ALPHA(1)	0	0.7	
DELTA(4)	0	0.6	

Flying Deployment Training			
What is the probability of Successfully completing 'Flying Deployment Training' based on the FPCON and % surge filled provided?			
FPCON	% surge filled	P(Success)	"+/-"
ALPHA(1)	100	0.99	0.03
ALPHA(1)	0	0.75	
DELTA(4)	0	0.65	

Appendix D. Acronyms

ACS Agile Combat Support

AcV Acquisition Viewpoint

AD Active Duty

AF Air Force

AFI Air Force Instruction

AFPD Air Force Policy Directive

ARC Air Reserve Component

AV All View(point)

C4ISR Command, Control, Communication, Computers, Intelligence, Surveillance,
Reconnaissance

CADM Core Architecture Data Model

CBA Capability Based Assessment

CBAM Capability Based Assessment Methodology

CBP Capability Based Planning

CCA Clinger-Cohen Act

CJCS Chairman of the Joint Chiefs of Staff

COCOM Combatant Commander

CONOPS Concept of Operations

CRRA Capability Review and Risk Assessment

CSAF Chief of Staff of the U.S. Air Force

CV Capability Viewpoint

DIV Data and Information Viewpoint

DM2 DoDAF Meta-Model

DoD Department of Defense

DoDAF Department of Defense Architecture Framework

DOTMLPF Doctrine, Organization, Training, Materiel, Leadership and Education,
Personnel, and Facilities

FAA Functional Area Analysis

FDT Flying Deployment Training

FFBD Functional Flow Block Diagram

FNA Functional Needs Analysis

FSA Functional Solutions Analysis

GE Good Enough Value

GFT Graduate Flying Training

ICOM Input Control Output Mechanism

IEEE Institute of Electrical and Electronics Engineers

IPL Integrated Priority List

ISO International Standards Organization

JCA Joint Capability Area

JCIDS Joint Capabilities Integration and Development System

JIC Joint Integrating Concept

JOC Joint Operating Concept

JROC Joint Requirements Oversight Council

LMV Limited Military Value

MAJCOM Major Command

MCL Master Capability Library

MFT Mission Flying Training

MODAF Ministry of Defense Architecture Framework

OSD Office of the Secretary of Defense

OV Operational View(point)

PAAR Potential Area to Accept Risk

POM Program Objective Memorandum

PPBE Planning Programming Budgeting and Execution

PSM Process Sequence Model

PV Project Viewpoint

RGS Requirements Generation System

SME Subject Matter Expert

SMP Strategic Master Plan

SOV Service Oriented Viewpoint

StdV Standards Viewpoint

StV Strategic Viewpoint

SvcV Service Viewpoint

SV Systems View(point)

TOGAF The Open Group Architecture Framework

TV Technical View

UFT Undergraduate Flying Training

UML Unified Modeling Language

Bibliography

- Air Force Directorate of Logistics (AF/A4LX). "United States Air Force Agile Combat Support CONOPS 2009 Capabilities Review and Risk Assessment (CRRA) Smartbook". 2008
- Air Force Link. "Air Force Fact Sheets". <http://www.af.mil/factsheets/>, April 2008
- Air Force office for Capability Based Planning, Operational Planning, Policy and Strategy (AF/A5X-C) Contractor Support team. "CRRA 2007 Development and Change Management Framework", version 1.0, 2007.
- Ambler, Scott. "Extending the RUP with the Zachman Framework." Figure from unpublished article.
<http://www.enterpriseunifiedprocess.com/essays/zachmanFramework.html>, 2004.
- Architecture. (2000). *The American Heritage Dictionary of the English Language* (p.94, 4th ed.). Boston: Houghton Mifflin Company.
- Blanchard, Benjamin S. and Wolter J. Fabrycky. *Systems Engineering and Analysis*. 4th ed. Upper Saddle River, New Jersey: Pearson Prentice Hall, 2006.
- Bonafede, Joseph A. and others. "The Risk Assessment for the HQ USAF's Capability Review and Risk Assessment (CRRA)," *24th International System Safety Conference*. Albuquerque, New Mexico, 31 July - 4 August 2006.
- Bonafede, Joseph A. and William F. Carrico, ARES Government Services. Personal Interview. 9 March 2009.
- Chairman Joint Chiefs of Staff. *Joint Capabilities Integration and Development System*. CJCS Instruction 3170.01F. Washington: CJCS, 1 May 2007.
- Chief Information Officers Council. *Federal Enterprise Architecture Framework*. Version 1.1. Washington: CIO, 4 August 1999.
- Department of the Air Force. *Air Force Concept of Operations Development*. AFI 10-2801. Washington: HQ USAF, 24 October 2005.
- . *Capabilities-Based Requirements Development*. AFI 10-601. Washington: HQ USAF, 31 July 2006.
- Department of Defense. *Department of Defense Architecture Framework version 1.5*, Vol 1. Washington: DoD, 23 April 2007.

- . *Department of Defense Architecture Framework version 2.0, Vol 1 DRAFT*. Washington: DoD, 10 December 2008a.
- . *Department of Defense Architecture Framework version 2.0, Vol 2 DRAFT*. Washington: DoD, 10 December 2008b.
- . *Quadrennial Defense Review Report*. Washington: DoD, 30 September 2001.
- Department of Defense Chief Information Officer. *Department of Defense Chief Information Officer Desk Reference*. Vol 1 Foundational documents. Washinton:DoD, August 2006.
- Ebeling, Charles E. *An Introduction To Reliability and Maintainability Engineering*. New York: The McGraw-Hill Companys, Inc.,1997.
- Eller, John, Brian Hazel, and Brendan Rooney. *Global Persistent Attack: A Systems Architecutre, Process Modeling, and Risk Analysis Approach*. MS Group Research Project, AFIT/ISE/ENV/08-J04. School of Engineering and Management, Air Force Institute of Technology (AU), Wright-Patterson AFB OH, June 2008.
- Functional Assessment Team (FAT) Meeting, Personal Interviews with AF CONOPS Champions, AF/A4, AF/A5, AF/A9, SAF/XC, and Booz Allen Hamilton, 18 – 21 November 2008.
- General Accounting Office. *A Framework for Assessing and Improving Enterprise Architecture Management*. Washington: GAO, April 2003.
- Holloway, Charles A. *Decision Making Under Uncertainty: Models and Choices*. Englewood Cliffs, NJ: Prentice-Hall Inc, 1979.
- Hurwitz, Judith and others. *Service Oriented Architecture for Dummies*. Hoboken, NJ: For Dummies, 2006.
- HQ USAF. “10 Step Brief.” Briefing Slides. 15 September 2006.
- . “A5X-C Capability Based Assessment Methodology.” Briefing Slides. 8 October 2007 .
- . “ACS SME Training Agenda.” Briefing Slides, 15-16 October 2008a.
- . “Consequence Value Function Training.” Briefing Slides. 7 November 2008b.
- . “CRRA PSM Node Tutorial.” Briefing Slides, 19 October 2007.

- Jacques, David R., Class Lecture Slides, SENG 520, Joint Capabilities Integration and Development System (JCIDS). Graduate School of Engineering and Management, Air Force Institute of Technology, Wright-Patterson AFB OH, September, 2006.
- Janus, Glen AFMC/A5CA Capability Requirements Division, ACS Flight Lead office. Personal Interview. 23 Oct 2008.
- Johnson, Lee W., and others. *Introduction to Linear Algebra*. 3rd ed. Reading, Mass: Addison-Wesley Publishing Co, 1993.
- Joint Chiefs of Staff/J-8 Capabilities and Acquisition Division. *JCIDS Overview*. 30 November, 2005.
- Joint Chiefs of Staff/J-8 Force Structure, Resources, and Assessment Directorate. *Capabilities-Based Assessment User's Guide (Version 2)*. Washington: JCS, December, 2006.
- Kurkowski, Stuart H. Class Lecture, CSCE 590, Engineering Software Intensive Systems. School of Engineering and Management, Air Force Institute of Technology, Wright-Patterson AFB OH, 2007.
- Larman, Craig. *Applying UML and Patterns*. 2nd ed. Upper Saddle River, NJ: Prentice Hall PTR, 2002.
- Larsen, Bob. "Evolution of the JROC Warfighting Capability-Based Assessments," *Phalanx*, Vol. 37 No. 4:2-12 (December 2004).
- Maier, Mark W. and Eberhardt Rehtin. *The Art of Systems Architecting* (2nd Edition). Boca Raton FL: CRC Press, 2002.
- MODAF Handbook, version 1.2.003, Crown Copyright 2004-2008, *The MOD Architecture Framework Version 1.2*, 22 September 2008
- Neter, John and Others. *Applied Linear Statistical Models*. 4th ed. Boston: WCB McGraw-Hill, 1996.
- Rehtin, Eberhardt. *Systems Architecting: Creating & Building Complex Systems*. Upper Saddle River NJ: Prentice Hall, 1991.
- The Open Group Architecture Framework (TOGAF). "Introduction." Excerpt from unpublished article. n. pag. <http://www.opengroup.org/architecture/togaf8-doc/arch/>. 2008
- Walker, Stephen K. *Capabilities-Based Planning – How it is intended to work and challenges to its successful implementation*. MS Thesis, US Army War College

Strategy Research Project. US Army War College, Carlisle Barracks, Carlisle PA,
18 March 2005.

Zachman, J. A. "A Framework for Information Systems Architecture," *IBM Systems Journal*, Vol 26, No 3:276-292 (1987).

REPORT DOCUMENTATION PAGE

Form Approved
OMB No. 074-0188

The public reporting burden for this collection of information is estimated to average 1 hour per response, including the time for reviewing instructions, searching existing data sources, gathering and maintaining the data needed, and completing and reviewing the collection of information. Send comments regarding this burden estimate or any other aspect of the collection of information, including suggestions for reducing this burden to Department of Defense, Washington Headquarters Services, Directorate for Information Operations and Reports (0704-0188), 1215 Jefferson Davis Highway, Suite 1204, Arlington, VA 22202-4302. Respondents should be aware that notwithstanding any other provision of law, no person shall be subject to a penalty for failing to comply with a collection of information if it does not display a currently valid OMB control number.
PLEASE DO NOT RETURN YOUR FORM TO THE ABOVE ADDRESS.

1. REPORT DATE (DD-MM-YYYY) 26-03-2009		2. REPORT TYPE Master's Thesis		3. DATES COVERED (From - To) Jun 2008 - Mar 2009		
4. TITLE AND SUBTITLE Application of reliability and linear regression to enterprise architecture in support of the US Air Force's Capability Review and Risk Assessment				5a. CONTRACT NUMBER		
				5b. GRANT NUMBER		
				5c. PROGRAM ELEMENT NUMBER		
6. AUTHOR(S) Mastro, Peter C., Capt, USAF Orcutt, Richard L., Capt, USAF				5d. PROJECT NUMBER		
				5e. TASK NUMBER		
				5f. WORK UNIT NUMBER		
7. PERFORMING ORGANIZATION NAMES(S) AND ADDRESS(S) Air Force Institute of Technology Graduate School of Engineering and Management (AFIT/EN) 2950 Hobson Way WPAFB OH 45433-7765				8. PERFORMING ORGANIZATION REPORT NUMBER AFIT/GSE/ENV/09-M05		
9. SPONSORING/MONITORING AGENCY NAME(S) AND ADDRESS(ES) Alice Maddox SAF/XCPA 1401 Wilson Blvd., Suite 600 Arlington VA 22209				10. SPONSOR/MONITOR'S ACRONYM(S)		
12. DISTRIBUTION/AVAILABILITY STATEMENT APPROVED FOR PUBLIC RELEASE; DISTRIBUTION UNLIMITED				11. SPONSOR/MONITOR'S REPORT NUMBER(S)		
13. SUPPLEMENTARY NOTES This material is declared a work of the U.S. Government and is not subject to copyright protection in the United States.						
14. ABSTRACT This research explored the use of modeling and enterprise architecture in the analysis of Air Force Capabilities. The Air Force accomplishes this through the Capability Review and Risk Assessment (CRRA). The CRRA is currently performed by building architectures which contain Process Sequence Models (PSMs). PSMs are scored by Subject Matter Experts to determine the probability of successfully completing the mission they model and ultimately to determine the risk associated to Air Force capabilities. Two findings were identified. The first is that creating additional architectural viewpoints, some of which are currently being proposed for version 2.0 of the DoD Architecture Framework, can benefit CRRA development. The second is PSMs have fundamental limitations associated with the inability to capture dependencies among activities as well as the inability to get beyond binary success criteria to address issues of capability sufficiency. To remedy these limitations a model called Extended Sequence Models (ESMs) was developed. ESMs extend PSMs by using reliability modeling techniques combined with linear regression to show dependencies between components. This model also allows the effects of capability sufficiency to be captured and related to mission success.						
15. SUBJECT TERMS Capability Review and Risk Assessment (CRRA), Process Sequence Modeling (PSM), decision analysis, architecture						
16. SECURITY CLASSIFICATION OF:			17. LIMITATION OF ABSTRACT	18. NUMBER OF PAGES	19a. NAME OF RESPONSIBLE PERSON	
a. REPORT	b. ABSTRACT	c. THIS PAGE	U	126	Dr. David R. Jacques, AFIT/ENV	
U	U	U			19b. TELEPHONE NUMBER (Include area code) 937-255-3355 x 3329 David.Jacques@afit.edu	

Standard Form 298 (Rev. 8-98)
Prescribed by ANSI Std. Z39-18