

ESTCP Cost and Performance Report

(ER-9917)



Portable SERS Instrument for Explosives Monitoring

January 2008



ENVIRONMENTAL SECURITY
TECHNOLOGY CERTIFICATION PROGRAM

U.S. Department of Defense

Report Documentation Page

*Form Approved
OMB No. 0704-0188*

Public reporting burden for the collection of information is estimated to average 1 hour per response, including the time for reviewing instructions, searching existing data sources, gathering and maintaining the data needed, and completing and reviewing the collection of information. Send comments regarding this burden estimate or any other aspect of this collection of information, including suggestions for reducing this burden, to Washington Headquarters Services, Directorate for Information Operations and Reports, 1215 Jefferson Davis Highway, Suite 1204, Arlington VA 22202-4302. Respondents should be aware that notwithstanding any other provision of law, no person shall be subject to a penalty for failing to comply with a collection of information if it does not display a currently valid OMB control number.

1. REPORT DATE 01 JAN 2008	2. REPORT TYPE N/A	3. DATES COVERED -	
4. TITLE AND SUBTITLE Portable SERS Instrument for Explosives Monitoring		5a. CONTRACT NUMBER	
		5b. GRANT NUMBER	
		5c. PROGRAM ELEMENT NUMBER	
6. AUTHOR(S)		5d. PROJECT NUMBER	
		5e. TASK NUMBER	
		5f. WORK UNIT NUMBER	
7. PERFORMING ORGANIZATION NAME(S) AND ADDRESS(ES) ESTCP Program Office 901 North Stuart Street, Suite 303 Arlington, VA 22203		8. PERFORMING ORGANIZATION REPORT NUMBER	
9. SPONSORING/MONITORING AGENCY NAME(S) AND ADDRESS(ES)		10. SPONSOR/MONITOR'S ACRONYM(S)	
		11. SPONSOR/MONITOR'S REPORT NUMBER(S)	
12. DISTRIBUTION/AVAILABILITY STATEMENT Approved for public release, distribution unlimited			
13. SUPPLEMENTARY NOTES The original document contains color images.			
14. ABSTRACT			
15. SUBJECT TERMS			
16. SECURITY CLASSIFICATION OF:			17. LIMITATION OF ABSTRACT
a. REPORT unclassified	b. ABSTRACT unclassified	c. THIS PAGE unclassified	UU
			18. NUMBER OF PAGES 41
			19a. NAME OF RESPONSIBLE PERSON

COST & PERFORMANCE REPORT

Project: ER-9917

TABLE OF CONTENTS

	Page
1.0 EXECUTIVE SUMMARY	1
1.1 BACKGROUND	1
1.2 OBJECTIVES OF THE DEMONSTRATIONS	1
1.3 REGULATORY DRIVERS	2
1.4 DEMONSTRATION RESULTS.....	2
1.5 STAKEHOLDER/END-USER ISSUES	2
2.0 TECHNOLOGY DESCRIPTION	5
2.1 TECHNOLOGY DEVELOPMENT AND APPLICATION.....	5
2.2 PROCESS DESCRIPTION	6
2.3 ADVANTAGES AND LIMITATIONS OF THE TECHNOLOGY.....	7
3.0 DEMONSTRATION DESIGN	11
3.1 PERFORMANCE OBJECTIVES	11
3.2 SELECTION OF TEST SITES	11
3.3 TEST SITES/FACILITY HISTORIES/CHARACTERISTICS.....	12
3.4 PHYSICAL SETUP AND OPERATION	13
3.5 SAMPLING/MONITORING PROCEDURES	13
3.6 ANALYTICAL PROCEDURES.....	14
4.0 PERFORMANCE ASSESSMENT	17
4.1 PERFORMANCE DATA.....	17
4.1.1 Basic Analytical Performance.....	17
4.1.2 Statistical Analysis.....	18
4.2 PERFORMANCE CRITERIA	19
4.3 DATA ASSESSMENT.....	19
4.4 TECHNOLOGY COMPARISON.....	19
5.0 COST ASSESSMENT.....	21
5.1 COST REPORTING AND ANALYSIS	21
5.2 COST COMPARISON.....	22
6.0 IMPLEMENTATION ISSUES	25
6.1 COST OBSERVATIONS.....	25
6.2 PERFORMANCE OBSERVATIONS.....	25
6.3 SCALE-UP	25
6.4 OTHER SIGNIFICANT OBSERVATIONS.....	26
6.5 LESSONS LEARNED.....	26
6.6 END-USER ISSUES	26

TABLE OF CONTENTS (continued)

	Page
6.7 APPROACH TO REGULATORY COMPLIANCE AND ACCEPTANCE.	26
7.0 REFERENCES	29
APPENDIX A POINTS OF CONTACT.....	A-1

LIST OF FIGURES

	Page
Figure 1.	Schematic Representation of the Portable Raman Instrument..... 5
Figure 2.	Photograph of the Portable Raman Instrument in the Trunk of a Rental Car at the ALAAP. 6
Figure 3.	SERS Spectrum of a Mixture of RDX, HMX, TNT, and TNB in UMCD Groundwater. 9
Figure 4.	Experimental Flow Chart for Analysis of Split Water Samples. 15

LIST OF TABLES

	Page
Table 1.	SERS Performance..... 7
Table 2.	Performance Objectives..... 11
Table 3.	Method Detection Limits 17
Table 4.	Accuracy and Precision of Analytical Methods..... 18
Table 5.	SERS Performance Summary..... 19
Table 6.	SERS Cost Tracking. 21
Table 7.	Comparison of Method Costs. 23

ACRONYMS AND ABBREVIATIONS

ALAAP	Alabama Army Ammunition Plant
ARA	Applied Research Associates
CCD	charge-coupled device
CPT	cone penetrometer
CRREL	Cold Regions Research Environmental Laboratory
DI	deionized (water)
2,4-DNT	2,4-Dinitrotoluene
2,6-DNT	2,6-Dinitrotoluene
DoD	Department of Defense
EPA	Environmental Protection Agency
GAC	granular activated carbon
HMX	Octahydro-1,3,5,7-tetranitro-1,3,5,7-tetrazocine
HPLC	high performance liquid chromatography
MDL	method detection limit
OSHA	Occupational Safety and Health Administration
OSW	Office of Solid Waste
RDX	Hexahydro-1,3,5-trinitro-1,3,5-triazine
RPD	relative percent difference
RSD	relative standard deviation
SDI	Silt Density Index
SERS	surface-enhanced Raman spectroscopy
SW	solid waste
TNB	2,4,6-Trinitrobenzene
TNT	2,4,6-Trinitrotoluene
UMCD	Umatilla Chemical Depot
USACE	U.S. Army Corps of Engineers
VAAP	Volunteer Army Ammunition Plant

This page left blank intentionally.

ACKNOWLEDGEMENTS

The authors gratefully thank Doug Webb and Andrejs Dimbirs of the U.S. Army Corps of Engineers, Connie Samson and Max Wilkinson of SAIC, and Mark Varljen of SCS Engineers for their generous field demonstration support. We also thank Steve Farrington of ARA and Tiny Grant of the University of New Hampshire for their statistical support to the project.

Technical material contained in this report has been approved for public release.

This page left blank intentionally.

1.0 EXECUTIVE SUMMARY

1.1 BACKGROUND

The costs for initial characterization, remediation monitoring, and long-term, post-remediation monitoring of groundwater contaminated with explosives are increasing as live firing ranges, ammunition depots, ordnance test facilities, and other Department of Defense (DoD) sites come under ever closer scrutiny. Major elements of the expense for characterization and monitoring are collection, packaging, shipping, and laboratory analysis of samples. The reference laboratory procedure for explosives is EPA solid waste (SW)-846 Method 8330. However, as pointed out by Jenkins and his colleagues, most samples test blank, wasting time and monetary resources on the laboratory procedure (Walsh et al., 1993; Jenkins et al., 1994; and Crockett et al., 1998). Those samples that do test positive can be characterized by analyzing for just a few explosives, most notably 2,4,6-Trinitrotoluene (TNT), 2,4-Dinitrotoluene (2,4-DNT) and Hexahydro-1,3,5-trinitro-1,3,5-triazine (RDX), obviating the need for a complete Method 8330 analysis. Furthermore, the conventional approach is not well suited for monitoring active remediation processes such as pump-and-treat systems because turnaround times for laboratory results are too slow for process control.

Colorimetric and immunoassay field methods have been developed as faster, cheaper, more portable alternatives to the lab method (Jenkins et al., 1994; Crockett et al., 1998; Keuchel et al., 1992; Keuchel and Niessner, 1994; Teaney et al., 1995; Jenkins et al., 1995; and Craig et al., 1996). However, these techniques have limitations—most notably their inability to detect more than a single analyte or class of analytes per test—such that the development and implementation of new approaches is warranted. In this project, a new method based on surface-enhanced Raman spectroscopy (SERS) has been developed. Raman is a vibrational spectroscopic method that produces a unique “fingerprint” spectrum for each analyte, allowing the components of a mixture to be discriminated in a single test. Normally a weak phenomenon, the Raman signal is enhanced up to 10⁶ by adsorbing analytes onto a noble metal surface (colloidal gold, in this case), rendering it suitable for trace analysis. This project was designed to field and demonstrate the potential of SERS to reduce (versus lab and field methods) the time, cost, and waste generated per analysis while providing discriminate quantification of multiple analytes (even those within a chemical class) in a single measurement.

1.2 OBJECTIVES OF THE DEMONSTRATIONS

This project entailed three demonstrations at two Army facilities, Alabama Army Ammunition Plant (ALAAP) and Umatilla Chemical Depot (UMCD). The demonstration objectives were to:

- (1) Demonstrate the general fieldability and ease of use of the SERS instrument
- (2) Demonstrate capability for quantifying multiple explosives (TNT, 2,4-DNT, 2,4,6-Trinitrobenzene (TNB), RDX, and Octahydro-1,3,5,7-tetranitro-1,3,5,7-tetrazocine [HMX]) in a single measurement
- (3) Demonstrate capability for at-line remediation process monitoring using the SERS method

- (4) Demonstrate capability for in situ and ex situ groundwater monitoring from a cone penetrometer (CPT) platform
- (5) Demonstrate improved capability for discriminating explosives versus colorimetry
- (6) Demonstrate the cost benefit of the SERS technology.

As will be described in the remainder of this report, all six cost and performance objectives of this project have been met.

1.3 REGULATORY DRIVERS

The Environmental Protection Agency (EPA) has not established health standards for explosives such as TNT and RDX in water; however, health advisories have been issued (U.S. EPA, 2004). At virtually all DoD sites where groundwater has been found to be contaminated with explosives at $\mu\text{g/L}$ to mg/L concentrations, regulators require groundwater well sampling and analysis as a major component of cleanup programs. During the remediation and post-remediation phases of cleanup, which can last up to decades, monitoring is required for process control, performance measurement, and compliance. The extended duration and expense of required monitoring programs create the need for faster, better performing, and lower cost monitoring technologies such as SERS, as proven in this project.

1.4 DEMONSTRATION RESULTS

Sections 3-5 of this report describe in detail the demonstration results, including SERS method performance. In summary, this demonstration has proven some of the most important advantages of SERS, namely:

- Reliable quantification of important individual explosives in water samples at concentrations of regulatory relevance
- Faster results and lower cost than laboratory Method 8330
- Comparable speed, lower cost, simpler procedures, less matrix interference, and better discrimination of individual explosives compared to colorimetry
- Applicability to virtually any environmental water monitoring application such as groundwater well monitoring, expedited site characterization (CPT), and remediation process monitoring

1.5 STAKEHOLDER/END-USER ISSUES

At ALAAP and UMCD, immunoassay and colorimetric field methods have been used in the past but were discontinued because of cross reactivity, background interference, and the inability to quantify individual species in samples containing multiple analytes. U. S. Army Corps of Engineers (USACE) engineers in both districts, as well as contractors performing the analytical work at both sites, have expressed interest in using new methodologies if they are sensitive to the low $\mu\text{g/L}$ concentration range and can discriminate between the major explosives present (TNT, 2,4-DNT, RDX, 2,6-Dinitrotoluene (2,6-DNT), and HMX). Following the successful

demonstration, one contractor is considering the purchase of a Raman (SERS) instrument for use in their explosives groundwater monitoring effort; another is seeking funding to further apply the SERS technology for remote, unattended, multipoint process monitoring. The SERS method is ready for implementation at DoD installations and other sites. EPA's recent acceptance of performance-based standards should allow many sites to deploy the technology, using the results of this demonstration to support the use of the method.

This page left blank intentionally.

2.0 TECHNOLOGY DESCRIPTION

2.1 TECHNOLOGY DEVELOPMENT AND APPLICATION

Raman spectroscopy is a high-resolution, vibrational spectroscopic technique where each molecule produces a unique spectral “fingerprint” that can be used to identify and differentiate it from other sample components (see Figure 3 in Section 2.3 for an example). Recent advances in lasers, detectors, and optical filter technologies have enabled considerable downsizing of Raman instrumentation such that field deployment is now feasible. SERS is a variation of conventional Raman spectroscopy whereby analytes are adsorbed onto a noble metal surface prior to analysis. Through a combination of chemical and electromagnetic effects, the Raman signal intensity is “enhanced” by as much as 10⁶ in SERS. Water exhibits little or no surface enhancement effect and does not interfere. Thus, the method is intended for field analysis of a broad range of explosives (including TNT, DNT, and RDX) in groundwater and remediation process water samples. These samples are generated as part of initial site characterization, remediation monitoring, and long-term, post-remediation monitoring activities at live firing ranges, ammunition depots, ordnance test facilities, and other DoD sites.

We assembled the portable Raman system depicted in Figure 1 to perform SERS analysis. The major instrument components are a diode laser and compact spectrograph equipped with an air-cooled, multichannel charge-coupled device (CCD) detector interfaced to a portable computer for data collection and processing. Both the laser and spectrograph are of shoebox size and are coupled to a duplex fiber optic Raman probe, as depicted in Figure 1 and photographed in Figure 2. One optical fiber guides laser light to the sample; the second optical fiber delivers backscattered Raman light to the spectrograph for detection. For ex situ ground or process water monitoring, the fiber optic probe is relatively short (3 m fiber length) and terminates in a sampling chamber into which water samples are introduced in small cuvettes. The sample chamber holds the Raman probe in proper alignment to the sample and blocks ambient light from reaching the probe during the measurement. A sliding cover allows samples to be quickly swapped in and out of the chamber. The system operates with 120V AC power, often supplied from a car battery using an inverter.

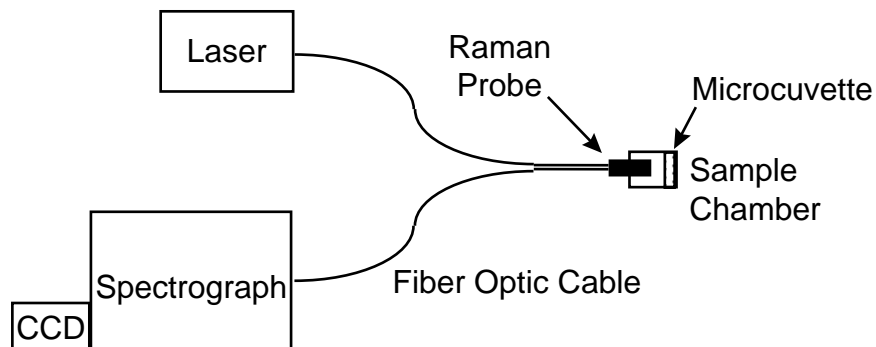

Figure 1. Schematic Representation of the Portable Raman Instrument.



Figure 2. Photograph of the Portable Raman Instrument in the Trunk of a Rental Car at the ALAAP. (The laser (blue) is sitting on top of the spectrograph (white) with a multichannel CCD detector (light blue) attached. In the foreground is the fiber optic Raman probe inserted in the sample chamber. Reagents for the SERS method are in the muffin tin.)

Although a diversity of metal surfaces has been successfully implemented for SERS, we have developed a simple “cocktail” using aggregated, commercially available colloidal gold particles for Raman enhancement. Sample preparation is straightforward, involving just a mixing of 0.5 mL of colloidal gold formulation with 0.5 mL filtered (0.45 μ m) water sample, waiting 1 min, and then performing Raman analysis for 5 min. Prior to mixing with the gold, the sample pH is checked and adjusted with acid or base if outside the range 3-12. The colloid formulation is buffered to ensure that aggregation of the gold particles is consistent and the responses are therefore reproducible. Greater sensitivity can be achieved by preconcentrating explosives on solid phase extraction media using standard procedures developed for colorimetric water assays (Jenkins et al., 1994; Craig et al., 1996).

2.2 PROCESS DESCRIPTION

The SERS instrument and method do not have extensive mobilization, installation, and operational requirements—all can be accomplished by one person. Mobilization is easily accomplished in the trunk of a car, as shown in Figure 2. Setup and preparation for analysis on site requires less than an hour on a small work area (approximately half the size of a desk). The analysis procedures described in the previous subsection can be performed by a trained individual in under 15 min. The level of expertise needed to perform the analysis is comparable to that required for colorimetric field methods. This level of expertise is often understated; in reality, a technician with chemical handling skills is required to perform the method accurately, reproducibly, and safely. Special Occupational Safety and Health Administration (OSHA) training is not required but is recommended for non-chemists and may be required at many field sites. An operator can be trained to proficiency in a day.

There is no routine maintenance required for the SERS instrument, which should provide years of service. Raman instrumentation is best returned to the factory for repair. If the end of the fiber optic probe becomes dirty, as indicated by a loss of optical power (weak response), it can be simply cleaned with alcohol on lens tissue. Sampling equipment requires periodic cleaning.

The general performance of the SERS method is summarized in Table 1.

Table 1. SERS Performance.

Type of Performance Objective	Primary Performance Criteria	Performance
Qualitative	1. Fieldability	Fielded five times without any problems
	2. Ease of use	Three new users found SERS facile
	3. Matrix effects	No statistical bias in SERS results
Quantitative	1. Analytical performance	MDL* 2.6 to 5.1 µg/L for five major explosives; linear range to 500 µg/L
	2. Spectral Resolution	Resolved four—RDX, HMX, TNT, and TNB
	3. Speed	7-12 min/sample
	4. Waste generated	1-3 mL/sample

*MDL = method detection limit

2.3 ADVANTAGES AND LIMITATIONS OF THE TECHNOLOGY

For the intended applications of the SERS technology, the major elements of the expense for conventional characterization and monitoring are collection, packaging, shipping, and laboratory analysis of samples. The reference laboratory procedure for explosives is EPA SW-846 Method 8330, a high performance liquid chromatography (HPLC) method for analyzing 14 explosives and co-contaminants. Method 8330 is generally suitable for the analysis of water samples collected from groundwater wells. However, as pointed out by Jenkins and his colleagues most samples test blank, wasting time and monetary resources on the laboratory procedure (Walsh et al., 1993; Jenkins et al., 1994; and Crockett et al., 1998). Those samples that do test positive can be characterized by analyzing for just a few explosives, most notably TNT, 2,4-DNT and RDX, obviating the need for a complete Method 8330 analysis. Furthermore, the conventional approach of sampling and laboratory analysis is not well suited for monitoring active remediation processes such as pump-and-treat systems because turnaround times for laboratory results are too slow for process control.

The principal advantages of SERS over the reference HPLC analytical Method 8330 are speed, cost, and waste generated. By eliminating sample packaging, shipping to a contract laboratory, storage, preparation, and a lengthy laboratory analytical procedure, the field SERS method can significantly reduce the cost per sample and reduce the turnaround time for reporting results from days or weeks to about 10 min. A further advantage of SERS is that samples of about 1 mL volume are analyzed, saving on expensive disposal costs. This efficiency contrasts markedly with the reference HPLC method, which generates 100-fold or more waste volume per sample compared to the SERS method. The SERS method also generates less waste than colorimetric and immunoassay methods, discussed below, although the reductions are not as significant (near 10-fold). Working with small samples also saves on reagent costs.

Analytical performance is the primary limitation of SERS versus Method 8330. Without sample preconcentration, SERS detection limits are higher than the HPLC method, especially for the nitramines. As measured by percent relative standard deviation (RSD), the precision of Method 8330 is also nearly an order or magnitude better than SERS. The accuracy of Method 8330 is slightly better than SERS. However, sampling error is normally much larger than analytical error, so the performance advantages of the reference method may not be realized.

An alternative to the current Method 8330 approach is to use faster, less expensive, and more portable methods to perform measurements on water samples collected in the field. Indeed, field methods based on colorimetric and immunoassay techniques have been developed. There are, however, limitations to both techniques that warrant the development and implementation of new approaches. For example, the time required for colorimetric analysis is quite long (approaching one hour), and a preconcentration step is required. Even the immunoassay time of 15 min per sample is not ideal for process control, especially when multipoint monitoring is desired. Although the costs for both methods are lower than for a laboratory Method 8330 HPLC analysis, faster methods offer to reduce costs even further.

A major limitation of both colorimetric and immunoassay methods is the range of applicability. The best immunoassay kits detect a single analyte and are available only for TNT and RDX. This limits their overall applicability to sites with these explosives. The colorimetric methods have broader applicability than immunoassay techniques, with each colorimetric procedure responding to a class of chemicals such as nitroaromatics or nitramines. While this makes colorimetry more generally applicable at explosive sites, it also limits the ability to quantitate specific analytes when multiple compounds in the same chemical class are present in a sample. With the colorimetric method, the potential for chemical and spectral interference is also higher than for immunoassay, although sample matrix effects and cross-reactivity of the immunoassay technique can be significant and vary nonlinearly with concentration.

The wider applicability of SERS is a distinct advantage—multiple analytes can be resolved and quantified in a single analysis. An example is shown in Figure 3 for a groundwater sample that contains detectable quantities of four explosives (TNT, TNB, RDX, and HMX), all of which can be spectrally resolved and quantified.

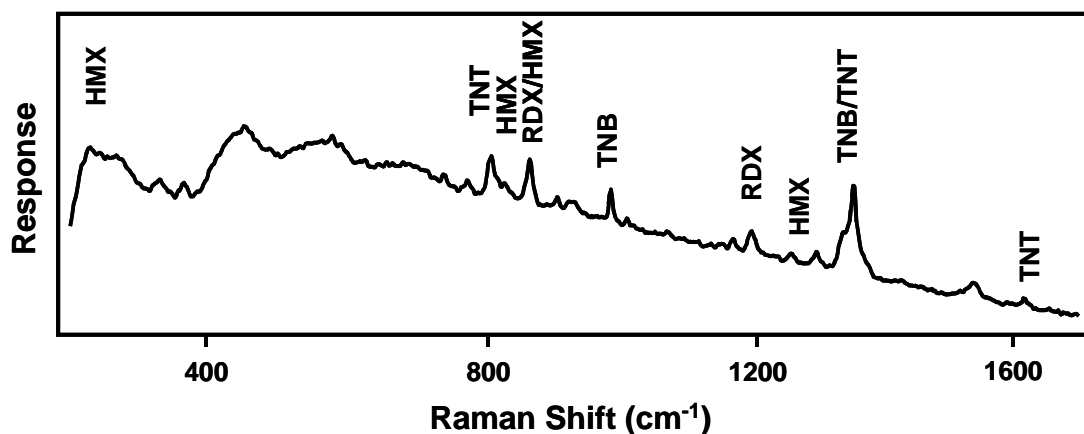

Figure 3. SERS Spectrum of a Mixture of RDX, HMX, TNT, and TNB in UMCD Groundwater.

Other metrics of analytical performance (detection limits, accuracy, precision, etc.) are comparable or favor SERS over colorimetry and immunoassay. Depending on the specifics of a site, additional potential advantages of SERS over colorimetry and immunoassay methods include speed, cost, and reduced sample matrix effects. For sites with a single analyte and a “clean” water matrix, the speed and cost of the field methods are similar.

This page left blank intentionally.

3.0 DEMONSTRATION DESIGN

3.1 PERFORMANCE OBJECTIVES

The performance objectives for the SERS demonstrations are summarized in Table 2 and formed the basis for evaluating the cost and performance of the SERS technology. As shown in the table, all the qualitative and quantitative objectives of the demonstrations have been met. Our cost goal was \$75 or less to quantify up to three analytes per sample, which is similar to single analyte immunoassay and colorimetry (undifferentiated analytes) costs and much less than the reference, two-column HPLC laboratory method (about \$250 for one analyte and \$25 for each additional analyte) with 30-day data turnaround. Laboratory costs vary widely for rapid turnaround samples but can be as high as \$1,000 per sample.

Table 2. Performance Objectives.

Type of Performance Objective	Primary Performance Criteria	Expected Performance (Metric)	Actual Performance
Qualitative	1. Fieldability	Successful fielding of the instrument	Fielded five times without any problems
	2. Ease of use	Potential operator acceptance	Three new users found SERS facile
	3. Matrix effects	Results not significantly affected by water parameters	No statistical bias in SERS results
Quantitative	1. Analytical performance (MDL, range)	Low $\mu\text{g/L}$ to $>100 \mu\text{g/L}$	MDL 2.6 to 5.1 $\mu\text{g/L}$ for five major explosives; linear range to 500 $\mu\text{g/L}$
	2. Spectral resolution	Three or more analytes	Resolved four—RDX, HMX, TNT, and TNB
	4. Speed	$<15 \text{ min/sample}$	7-12 min/sample
	5. Waste generated	$< 5 \text{ mL/sample}$	1-3 mL/sample

3.2 SELECTION OF TEST SITES

ALAAP was selected as the first test site because it had (1) significant quantities of multiple explosive analytes in the groundwater, (2) over three dozen groundwater wells, (3) difficulties with conventional field screening and Method 8330 analyses that indicated potential challenges to SERS and the other methods, (4) an ongoing groundwater monitoring program with a significant body of historical data, and (5) a receptive on-site contractor (SAIC). An alternate site, the Volunteer Army Ammunition Plant (VAAP), had similar characteristics but had a discontinuous groundwater sampling program which was not active at the time of the demonstration.

The UMCD facility was selected for the second test site because it satisfied the need for two demonstration sites—a groundwater remediation process and a subsurface plume of contamination. More specifically, the Explosives Washout Lagoons at UMCD had (1) a known history of mixed explosive analytes in the groundwater and (2) an ongoing groundwater monitoring program with historical data and a current groundwater model. The groundwater remediation system is an actively operating pump-and-treat (granular activated carbon [GAC])

system with sampling points in place. The UMCD facility was also readily accessible to Applied Research Associates' (ARA) Richland, Washington, based CPT rig, which has enhanced access (drilling) capabilities. The USACE in Seattle, Washington, also maintained considerable interest and provided valuable infrastructural support to the UMCD demonstrations.

3.3 TEST SITES/FACILITY HISTORIES/CHARACTERISTICS

ALAAP is located near Childersburg, Alabama. Smokeless powder, nitrocellulose and nitroaromatic explosives were manufactured at the site until 1988 when the plant was officially closed. Military activity is nonexistent. Originally over 13,000 acres in size, much of the site has been sold to private concerns with about 2,200 acres remaining under USACE-Mobile District oversight. ALAAP is unoccupied, and a single small building that supports the ongoing groundwater and surface water monitoring programs remains on the site. Historically, the primary groundwater contaminants identified at the site have been TNT, 2,4-DNT, and 2,6-DNT, although 2,6-DNT was not detected during the demonstration. Previous manufacturing practices suggest that tetryl could also be found in groundwater but has not yet been detected. Groundwater pH is neutral and generally flows in the direction of Talladega Creek, which is fortunately away from local municipal drinking water wells. From about 2000-2002 a series of over two dozen wells were developed at ALAAP. Additional wells have recently been constructed at locations near and outside the perimeter of the Alabama plant. Water sampling and analysis has not followed a regular quarterly schedule at the site but has been conducted at least twice a year. The schedule is impacted by local rainfall conditions, because analyte concentrations have typically been highest following periods of heavy rainfall. Thus, spring and fall sampling is normally conducted as soon as possible after heavy rainfall events so that conservative estimates of groundwater contamination can be made.

UMCD is located in northeastern Oregon in Morrow and Umatilla Counties, approximately 5 miles west of Hermiston, Oregon. The installation covers about 19,700 acres of land. UMCD was established as an Army ordnance depot in 1941 for the purpose of storing and handling munitions. From the 1950s until 1965, UMCD operated an explosives washout plant on site. Munitions were opened and washed with hot water to remove and recover explosives. The plant was cleaned weekly, and the washwater was disposed in two nearby lagoons where it percolated into the soil. The lagoons received an estimated total of 85 million gallons of washwater during plant operations. Although lagoon sludges were removed regularly during operation, explosives contained in the washwater migrated into the soil and groundwater 47 ft beneath the lagoons. There is a pronounced west-to-east gradient in depth to groundwater at the site, reaching 100-120 ft on the eastern edge of the plume. Because of the soil and groundwater contamination (RDX, TNT, HMX, and TNB), the lagoons were placed on EPA's National Priorities List in 1987. The pH of groundwater in the lagoons has historically been neutral.

As the first step to remediation of the site, the contaminated soil in the lagoons was removed in September 1994 and subjected to bio-treatment. The pump-and-treat (GAC) remediation system was installed later to treat explosives-contaminated groundwater and has been in operation since January 15, 1997. Based on pump-and-treat influent monitoring data and quarterly groundwater well monitoring, the RDX plume has been reduced slightly in size and concentrations have been reduced more than an order of magnitude in the center of the plume. However, in the northeast portion of the plume, concentrations have not declined during pump-and-treat operations.

Therefore, the Army Corps desires to better characterize the magnitude and extent of contamination in that area with the additional objective of placing a series of sentinel wells outside the minimum zone of contamination (2.1 µg/L).

Pump-and-treat remediation of the groundwater in the UMCD Explosives Washout Lagoons continues in full-scale operation today with oversight by the USACE-Seattle District. Regular groundwater remedial action monitoring is an integral part of the ongoing remediation program. Monitoring is accomplished using conventional sampling and contract laboratory colorimetric analysis with occasional (about annual) Method 8330 HPLC analysis. As discussed earlier in this report, the Army Corps has identified a need to better characterize the RDX plume in the northeast region of the site where concentrations have not been reduced by pump-and-treat operations. There is a potential concern that contaminants may be migrating in that direction, beyond the outermost monitoring wells. Thus, it is desirable to better define the plume boundary in that area and place sentinel wells to provide early detection of future contaminant migration.

3.4 PHYSICAL SETUP AND OPERATION

Fieldwork at ALAAP was conducted the third week of May 2002 in conjunction with routine water sample collection at the site. Both the SERS and colorimetry equipment are portable and were shipped as airline baggage and transported to the site in a rental car. In about an hour, the equipment was unpacked and set up on a desktop in the sample processing building on site. SERS analyses were also performed in the back of the rental car at three well heads (see Figure 2). In general, performing measurements at wells is not efficient because sample collection takes far longer than the analysis. Instead, it is more cost effective to first collect the samples over a several day period and then perform the analyses in a single day (or less). We used this approach at ALAAP where about half the samples were collected over a 4-day period and preserved on ice prior to our arrival at the site.

On the three visits to the UMCD GAC plant (September 2003, November 2003, and January 2004), the SERS and colorimetry equipment was set up on a portable folding table in the same manner as at ALAAP. Daily instrument calibration and response checks revealed no changes (damage) to the equipment during cross country shipment (Vermont to Washington), rental car transport to the site from Richland, Washington, or during the fieldwork periods. Each visit required a single day to mobilize to the site, set up, analyze the four process samples (influent, two intermediate, and effluent), and demobilize back to Richland. The visits were coordinated with regular sampling being conducted by SCS Engineers.

For the 2-week CPT demonstration at UMCD in mid-November 2003, the sampling and analytical equipment was installed in the back of the CPT truck.

3.5 SAMPLING/MONITORING PROCEDURES

Collection of groundwater from wells at ALAAP and process water samples at the UMCD GAC plant was coordinated with ongoing remedial investigation activities at the sites and was in accordance with the sampling plan contained in the demonstration plan. Sampling was conducted by on-site contractors (SAIC and SCS Engineers) who are experts in this area and followed approved procedures for the sites delineated in their remedial investigation plans. CPT

water samples were collected by trained ARA personnel using a commercial pneumatic bladder pump. The pump and tubing were cleaned with deionized (DI) water between samples. Receiving vessels were amber glass bottles with Teflon-lined caps. To avoid the high variability (uncertainty) of sampling, field “splits” were obtained.

The aforementioned on-site contractor sampling experts also handled the labeling, chain of custody, preservation, packing and shipping of samples to ARA/Cold Regions Research Environmental Laboratory (CRREL) and the independent reference laboratories in accordance with procedures prescribed under Method 8330. All analyses were performed within 48 hrs of sample shipment from ALAAP, resulting in a maximum holding time of 5 days, which was within the 7 days allowed under Method 8330. A trip DI blank was included with each shipment. Additionally, reagent blanks were run at the beginning of each day for each field or laboratory method and also tested clean in all cases.

A total of 56 water samples was collected during the demonstrations—32 groundwater well samples at ALAAP, 18 GAC plant samples at UMCD, and 6 CPT groundwater samples at UMCD.

3.6 ANALYTICAL PROCEDURES

Analytical procedures followed those prescribed in the Demonstration Plan. Split samples of groundwater were analyzed by SERS, colorimetry (using the procedures described in Jenkins et al., 1994 and Strategic Diagnostics, Inc.), and EPA SW-846 Method 8330. The split-sample approach is commonly used to validate on-site methods and avoids the considerable uncertainties of sample-to-sample variation. Because water samples are inherently homogenized, subsampling errors common in soil analysis are also avoided.

Figure 4 is a flow chart summarizing the experiments performed on each water sample in the ALAAP demonstration. The samples were split and analyzed in the field using SERS and colorimetric procedures. Each procedure was performed using duplicate aliquots carried through the entire procedure, and triplicate when explosives were detected. SAIC also sent splits of the samples to an independent certified contract laboratory (IT Corp.) for Method 8330 analysis as prescribed in the site remedial investigation plan. The remainder of each sample was sent to ARA/CRREL for further split analysis by SERS, colorimetry, and HPLC.

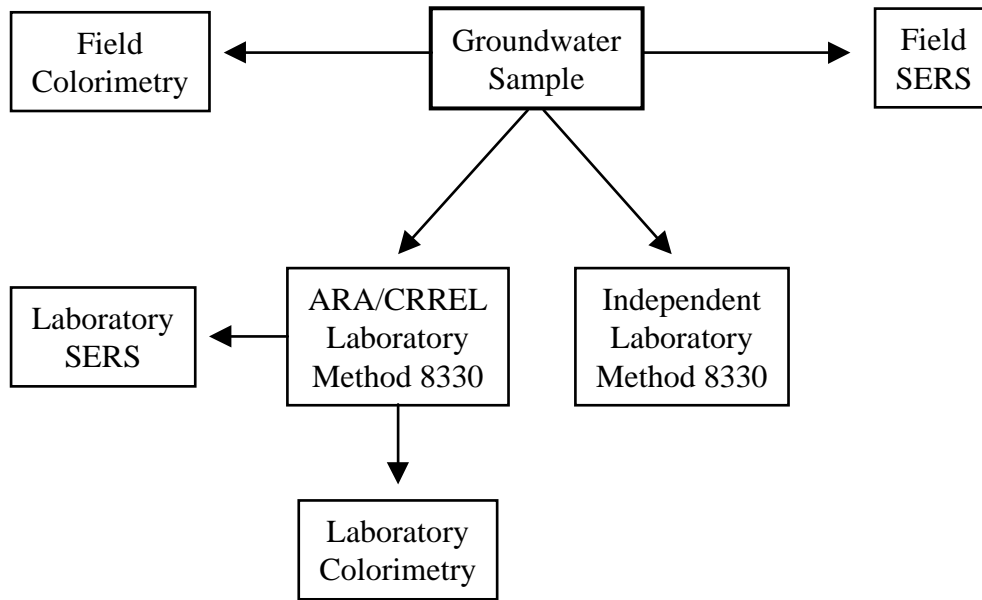

Figure 4. Experimental Flow Chart for Analysis of Split Water Samples.

A flow chart similar to Figure 4 applied to the GAC plant process water samples except that the independent laboratory method specified by the site process monitoring plan was colorimetry for all three sampling events except the last, when the independent laboratory also performed Method 8330 analysis. For the CPT demonstration, the independent laboratory performed colorimetry and there was an additional analysis (in situ SERS) performed on each of the six groundwater samples.

The split sample approach described above minimized the effects of sampling and potential holding time variances, allowing actual method performances to be more reliably compared.

Quality assurance and control were consistent with the procedures outlined in Method 8330 for laboratory HPLC analysis and recommended for colorimetric field screening (Crockett et al., 1998; Strategic Diagnostics, Inc.). In both the field and laboratory, the SERS response calibration was checked three times daily with an intermediate concentration standard (150 µg/L prepared daily from a refrigerated stock solution) containing all relevant analytes. In all cases, the responses were within +/- 15% of the expected value, obviating the need for recalibration of the SERS instrument. Wavelength calibration of the SERS instrument was performed with naphthalene upon arrival at each demonstration and thereafter checked at the beginning and midpoint of each day. There was no change in calibration (within one detector pixel, or 1.8 cm⁻¹) observed throughout the project. Indeed, the initial calibration at each site was not required as there was no change from the laboratory calibration. Following recommended procedures (Strategic Diagnostics), colorimetry response calibration was checked at the beginning of each day with TNT and/or RDX control standards (2 mg/L). Again, all responses were within +/- 15% of expected values and therefore did not require a change in calibration factor. HPLC quality followed Method 8330. More specifically, calibration verifications were performed at

the beginning of each day with an intermediate concentration standard (150 µg/L) mixture of all analytes. In the course of this project, all HPLC calibrations verified to within +/- 15% of the expected values. Retention time windows for each analyte were established at the beginning of each day and every 10 samples thereafter.

Statistical Methods and Hypothesis Testing

Statistical methods and hypothesis testing was performed in accordance with the Quality Assurance Project Plan. Statistical methods included measures of precision and accuracy to compare the analytical performance of the SERS method against the colorimetric and reference HPLC methods.

In addition, data pairs were generated for each sample (e.g., SERS and Method 8330). As such, this allowed paired statistical tests such as t-tests to be performed to compare methods. A useful framework for using paired tests to compare analytical methods is null hypothesis testing, whereby the claim that there is no statistically significant difference between the new (e.g., SERS) methodology and the reference (e.g., Method 8330) methodology is tested. More specifically, the null hypothesis (H_0) can be stated as “the mean of the population of differences between the two analytical methods is zero ($\mu=0$).” The null hypothesis can be evaluated against the alternative hypothesis ($H_0:\mu \neq 0$), that the mean difference is greater than or less than zero. On the basis of the random sample from the population, one decides whether to accept or reject the null hypothesis.

Both parametric (e.g., the Student test) and non-parametric (e.g., the Wilcoxon Signed Rank Test) hypothesis tests were performed, depending on the distribution of the population, as inferred from the distribution of the random sample obtained.

The analytical results included non-detects. When using the parametric t-test, pairs of two non-detects were dropped from the sample, reducing N accordingly. For paired results containing one non-detect, it was replaced by half the analytical detection limit. For the non-parametric Wilcoxon Signed Rank test, pairs of two non-detects were dropped from the sample, again reducing N accordingly. Pairs containing one non-detect were ranked according to the difference between the quantified result and half the detection limit for the Wilcoxon Signed Rank test.

Crockett et al. (1998), assert that when the concentrations of explosives cover a large range of values, regression methods for assessing precision and accuracy become appropriate. This is because as the variability in the sample concentration increases, the capability for the paired tests described above to detect differences in precision or bias decreases. Regression analysis is useful because it allows characterization of non-constant precision and bias effects and is normally performed with the reference analytical method (e.g., Method 8330) result as the independent variable. The concentrations measured at ALAAP and UMCD covered a wide range of values (low µg/L to mg/L); therefore, we applied regression analysis to the data.

4.0 PERFORMANCE ASSESSMENT

4.1 PERFORMANCE DATA

Complete data and a discussion of performance data can be found in the Final Report.

4.1.1 Basic Analytical Performance

Fundamental performance parameters established for the SERS method were the MDL, linear dynamic range, accuracy (measured as percent recovery of spiked samples), and precision (measured as percent RSD for replicate measurements). The linear dynamic range for SERS analysis of explosives is from the lower detection limit (~5 µg/L) to approximately 500 µg/L. The upper limit of the linear range exceeded our performance goal of 100 µg/L.

MDLs were determined with a set of eight replicate samples for the five explosives detected in the demonstrations at ALAAP and UMCD. Samples spiked at 15 µg/L in clean, filtered ALAAP groundwater matrix were used for the MDL test—15 µg/L was three times the estimated MDL of 5 µg/L. The SERS MDLs are presented in Table 3 along with MDLs for the HPLC and colorimetric methods. Our SERS performance goal of low µg/L MDLs was met; the MDLs are low enough to screen at all drinking water health advisory levels except Lifetime levels of 2 µg/L for RDX and TNT (U.S. EPA, 2004). In the case of the nitramines, a 10-fold sample preconcentration using established solid phase extraction procedures (Jenkins et al., 1994; Craig et al., 1996) was required to achieve the desired sensitivity. However, for colorimetry to reach a comparable MDL, a nearly 300-fold preconcentration (2 L water sample) was required. Without preconcentration, HPLC Method 8330 was consistently most sensitive. Because capability for preconcentration was not part of our CPT SERS probe, the MDL for RDX was well above groundwater concentrations, thereby obviating the effectiveness of in situ SERS at the site.

Table 3. Method Detection Limits (µg/L).

Analyte	SERS	HPLC	Colorimetry
2,4-DNT	3.8	2.0	0.7*
TNT	4.3	1.0	
TNB	5.7	0.5	
RDX	2.6*	1.0	2.8*
HMX	5.1*	1.0	

* With sample preconcentration

Table 4 summarizes the accuracy and precision of SERS versus HPLC and colorimetry. For nitroaromatics, SERS and HPLC had comparable accuracies. The accuracy of HPLC was superior for nitramines for which the SERS method is not as sensitive. The accuracies of the two colorimetric methods were lower than SERS and HPLC, especially for TNT, which was reported to exhibit a low recovery of 79.4% (Jenkins et al., 1994). HPLC Method 8330 precision was consistently better than SERS and colorimetry. However, the single-laboratory precision of SERS was better than multilaboratory HPLC precision reported in Method 8330. SERS precision was better for nitroaromatics than nitramines. This is not surprising considering the

additional error introduced by the preconcentration step used with the nitramines. Further optimization of the preconcentration step could potentially improve the precision for nitramines by 1-2% RSD. The preconcentration step may also account for the lower SERS recovery of HMX. Once again, the reported precision for colorimetry was not as favorable as the other methods, especially for nitramines (RDX, 26.8% RSD).

Table 4. Accuracy and Precision of Analytical Methods.

Analyte	Accuracy			Precision			
	SERS % Recovery	HPLC* % Recovery	Color** % Recovery	SERS % RSD	HPLC*** % RSD	Color** % RSD	HPLC Multilab* % RSD
2,4-DNT	96.7	98.6	---	3.4	0.6	---	7.2
TNT	94.7	94.4	79.4	3.8	0.4	7.3	10.4
TNB	91.9	---	---	4.7	1.6	---	---
RDX	93.3	99.6	91.2	5.0	0.9	26.8	7.6
HMX	89.3	95.5	---	5.8	2.1	---	7.3

*From SW-846 Method 8330 (Appendix A)

**Jenkins et al., 1994

***Jenkins et al., 1995

Overall, basic analytical SERS performance met the objectives of this project and was not far from the performance of the reference laboratory method. In general, SERS performance exceeded the colorimetric methods for nitramine and nitroaromatic explosives.

4.1.2 Statistical Analysis

Linear regression analysis, relative percent differences, and hypothesis testing using paired statistics formed the basis of our statistical comparison of SERS analytical performance versus the other two methods. The goals of this effort were to answer the following questions:

- Is field SERS an analytically acceptable alternative to HPLC or colorimetry for the analysis of explosives in water?
- Is the performance of SERS in the field comparable to laboratory SERS?
- Are there any significant performance differences for different explosive analytes?

These goals were met and the data support the following conclusions:

- Field SERS is an analytically acceptable alternative to HPLC or colorimetry for the analysis of explosives in water.
- The performance of SERS in the field is comparable to laboratory SERS.
- There is no consistent difference in SERS performance for different individual explosive analytes versus the reference Method 8330.
- There is no significant bias in the SERS method (i.e., matrix effects).

- SERS precision is better than interlaboratory reference method results but considerably poorer (~5-fold higher percent RSD and large relative percent difference [RPDs]) than the single laboratory HPLC method for all analytes

4.2 PERFORMANCE CRITERIA

The expected and actual performances of the SERS method are summarized in Table 5. The performance confirmation methods identified in the table, as well as the data analysis, interpretation, and evaluation were executed in accordance with the Demonstration Experimental Design and Sampling Plans as well as the Quality Assurance Project Plan. This ensured that reliable data was collected and a valid comparison of methods could be performed. The data quality parameters comparability and representativeness were ensured by the use of split samples throughout the project. Sufficient data was collected to evaluate SERS performance using the criteria listed in Table 5. Our data completeness goal for the project was 90%, with a minimum of 30 total valid samples. This goal was met with over 50 samples collected, all of which were valid.

4.3 DATA ASSESSMENT

The demonstration data support the conclusions in Section 4.1 as well as the actual performance summarized in Table 5. Overall, the data support the conclusion that all the claimed performance capabilities for the SERS technology have been met and demonstrated.

4.4 TECHNOLOGY COMPARISON

The SERS technology compared favorably with the reference HPLC Method 8330 and colorimetric methods. Refer to Section 4.1 for a comparison of methods.

Table 5. SERS Performance Summary.

Performance Criteria	Expected Performance Metric	Performance Confirmation Method	Actual
<i>Primary Criteria – Qualitative</i>			
Fieldability	Instrument can be used in the field	Experience from demo operations	Five fieldings without problems
Ease of use	Comparable to colorimetry	Experience from demo operations	Sample preparation simpler than colorimetry; instrumentation slightly more complex
<i>Primary Criteria – Quantitative</i>			
Analytical performance (MDL, range)	Low µg/L to >100 µg/L	EPA Method 8330 (see Appendix A of the Final Report)	MDL 2.6 to 5.1 µg/L; linear range to 500 µg/L
Spectral resolution	3 analytes or more	EPA Method 8330	Resolved four analytes in real-world samples
Speed	<15 min/sample	Observation/timing	7-12 min/sample
Process waste	<5 mL/sample	Observation/volumetric measurement	1-3 mL/sample

Table 5. SERS Performance Summary (continued).

Performance Criteria	Expected Performance Metric	Performance Confirmation Method	Actual
<i>Secondary Criteria</i>			
Factors affecting performance	pH no effect outside the range pH 3-12; turbidity no effect with filtering	Measure pH and filter samples; EPA Method 8330	All samples within 0.5 pH units of neutral (pH 7)
Safety	Gloves and eye protection	Experience from demo operations	No safety issues—gloves and eye protection used when handling samples or reagents
Versatility	Useful at other sites	Experience from demo operations	General utility for groundwater and process water monitoring demonstrated
Maintenance	None	Experience from demo operations	No maintenance required
Scalability constraints	None	Experience from demo operations	No interferences or matrix effects observed

5.0 COST ASSESSMENT

5.1 COST REPORTING AND ANALYSIS

Our goal in this project was to achieve an SERS analysis cost of less than \$75 per sample for “standard” water samples (i.e., using an analyst). We believe a similar cost target is reasonable for at-line process monitoring because the additional capital equipment costs for process monitoring equipment (sampling and control hardware as well as software) will be offset by lower operator labor costs. For example, at the UMCD GAC plant, annual monitoring costs are approximately \$100,000, most of which is labor related. With 20 years or more remediation monitoring expected, there is considerable opportunity for capital expenditure to reduce total costs. In the case of CPT-based analysis, the bulk of the cost is driven by the CPT costs (approximately \$4,000 per day) and thus analysis costs are of lesser significance. Nevertheless, CPT-based analysis costs are expected to be approximately the same as “standard” SERS analysis costs because the cost of sampling equipment is comparable to other commercial sampling systems and all other cost elements are the same as for “standard” SERS. In situ CPT SERS is somewhat more expensive due to additional equipment costs for specialized down-hole equipment and longer fiber optic cables that are expected to be replaced on an annual basis (refer to ancillary equipment in Table 6).

In order to assess the cost per sample as accurately as possible, we tracked the equipment, materials and labor costs during the course of the demonstration. Table 6 summarizes the major cost elements that were tracked. Other cost elements associated with site characterization, such as sampling, mobilization/demobilization, and environmental safety training, vary by site and are the same for both SERS and baseline technologies. Therefore, those elements do not significantly impact per sample costs and do not need to be considered in the cost comparison.

Table 6. SERS Cost Tracking.

Cost Category	Subcategory	Cost No Preconcentration	Cost Preconcentration	Cost In Situ CPT
Capital costs	Capital equipment purchase	\$52,000	\$52,000	\$52,000
	Ancillary equipment purchase	\$0	\$0	\$10,000/yr
Operating costs	Operator labor/sample (\$60/hr)	\$15	\$20	\$15
	Operator training (1 day)	\$480	\$480	\$480
	Consumables, supplies/sample	\$5	\$14	\$5
	Residual waste handling and disposal	negligible	negligible	negligible

Table 6 considers the difference in productivity and costs between samples requiring preconcentration (e.g., low µg/L detection of nitramines) and those that do not. Normally a \$60/hr (loaded cost) technician can analyze approximately four water samples an hour. Productivity is reduced to three samples an hour if preconcentration is required. For in situ CPT-

SERS, costs of the basic capital SERS equipment, consumables, and labor/sample are approximately the same as for “standard” SERS; however, it is assumed that the down-hole SERS module (\$6,000) and fiber optic cable (\$4,000) will have to be replaced annually due to wear or damage. SERS capital equipment is based on study purchase prices, which are as follows:

- Spectrograph \$15,000
- Detector \$15,000
- Raman probe \$5,000
- Laser \$12,000
- Computer \$2,000
- Software \$3,000

Raman equipment is currently considered specialty instrumentation and is not widely used outside laboratories. Thus, Raman equipment is not available for rental as an alternative to purchase.

The costs for reference laboratory Method 8330 and colorimetry analyses were obtained from SAIC and SCS Engineers. HPLC costs can vary widely (up to several thousand dollars per sample), depending on sample turnaround time, number of analytes reported, etc. To facilitate comparison with SERS and colorimetry, we obtained the costs for routine HPLC analysis reporting just two analytes. Both laboratories reported a lowest cost of \$150 per sample. The laboratory performing colorimetric analysis charged \$80 per sample for two tests—nitramines and nitroaromatics. The cost is \$50 for a single colorimetry test.

5.2 COST COMPARISON

The cost of the SERS technology is compared against colorimetry and Method 8330 in Table 7 using the major SERS cost drivers. The colorimetry cost estimate of \$42 agrees well with commercial prices of \$50 for a single test and previous reports comparing field method costs (Craig et al., 1996; Crockett et al., 1999). The HPLC cost was derived as discussed in Section 5.1. The waste generated by the SERS method is small and contributes negligibly to per-sample costs. HPLC generates considerably more waste per sample, contributing to the higher HPLC costs of \$150 per sample.

Considering only labor and consumables, the basic SERS method costs less than half a single colorimetric test and is well within our targeted price goal of \$75/test. However, if both nitramines and nitroaromatics are tested (at a total cost of about \$80), basic SERS costs (no preconcentration) drop to just 25% of colorimetry and 15% of HPLC costs. With preconcentration, SERS costs are still less than half the expense of colorimetry for two tests and about 25% of HPLC costs.

Table 7. Comparison of Method Costs.

SERS			Colorimetry		HPLC
Consumables	No Preconstruction	Preconstruction	Consumables		
Colloidal gold	\$1	\$3	Test kit silt density index (SDI)	\$25	
Filter	\$1	\$1	Alumina cartridge	\$2	
Vial, pipettes, etc.	\$2	\$3			
Solid phase cartridge	n/a	\$6			
Standards	\$1	\$1			
Subtotal	\$5	\$14	Subtotal	\$27	
Labor			Labor		
Technician (\$60/hr)	\$15	\$20	Technician (\$60/hr)	\$15	
Total	\$20	\$34	Total	\$42	\$150
Equipment			Equipment		
Raman spectrometer	\$52,000	\$52,000	Spectrophotometer	\$2,000	
Waste generated	1 mL	3 mL	Waste generated	25 mL	>> 25 mL

SERS life-cycle costs are dominated by capital equipment expenses that can be reasonably amortized over a 5-year period. A useful means to compare the costs of different methods that include capital equipment is to calculate the break-even point. For “standard” SERS, the break-even point (i.e., the number of samples that must be analyzed to pay off the equipment and immediately realize the lower per-sample costs identified in Table 6) against Method 8330 is 400 samples without preconcentration and 450 samples with preconcentration. Assuming both nitramines and nitroaromatics are analyzed in each sample, the break-even point against colorimetry is about 850 samples without preconcentration and about 1,100 samples with preconcentration. These numbers are small when considered over a 5-year period (only 100-200 or so samples per year). Viewed another way, the least favorable break-even point (against colorimetry with SERS preconcentration) is reached in a total cost of \$89,000, which is less than one year’s monitoring cost at the UMCD GAC plant. Clearly, SERS is a potentially cost-saving alternative to both HPLC and colorimetry.

In situ CPT SERS break-even points (without preconcentration only) are approximately double the “standard” SERS break-even points due to annual down-hole equipment replacement costs. Costs can be recouped faster, however, because a premium of up to \$500-\$1,000/day can be charged for specialized CPT work. However, most CPT SERS work is expected to be performed entirely up-hole (i.e., ex situ) because of the advantages of lower cost, less complexity, and greater opportunity for sample preparation (e.g., preconcentration).

This page left blank intentionally.

6.0 IMPLEMENTATION ISSUES

6.1 COST OBSERVATIONS

As discussed in Section 5, the cost of SERS is already highly competitive with other field methods, thereby offering the same cost advantages over conventional approaches. There is little opportunity for significant cost reductions in the near term.

The major per-sample cost drivers are labor and equipment costs. Equipment cost reductions could be realized in the future as technology breakthroughs are achieved in spectrographs, detectors, and lasers. Detector and laser costs are already dropping as other larger markets drive competitive pricing. The performance of both is also improving at the same time as prices drop. The specialized nature of high performance spectrographs will not likely see much price reduction, although technology breakthroughs in grating materials and processing, or entirely new approaches, could reduce prices.

Labor costs could be reduced through automation, such that a less educated/skilled person could perform analyses. Samples could simply be “injected” into a preparation unit, with all analytical procedures (filtering, pH reading/adjusting, mixing reagents, etc.) executed autonomously. Although the method is quite simple, automating all operations would prove difficult and costly to develop—raising up-front capital equipment costs even more. The addition of a sample preparation unit would also lead to higher maintenance issues that would likely require a person at the current skill level to resolve. Furthermore, skilled field technicians are normally already involved in the sampling process and will typically also be executing the field screening methods. Except on very large jobs, the cost of bringing in an additional, lower cost individual to run an automated analyzer would be prohibitive. The use of underskilled and/or undertrained personnel in performing field analysis is risky and highly discouraged. Costs rise dramatically when procedures are not followed properly and results are invalidated.

6.2 PERFORMANCE OBSERVATIONS

The observed performance of SERS met all goals, both primary and secondary, as summarized in Table 5. The data support the conclusion that the SERS instrument and methods are readily fieldable, durable (low maintenance), simple to set up and use, and very safe. Analytical performance is better than the other field methods but could be improved to meet or exceed that of the reference method. SERS MDL/precision, spectral resolution, and speed could potentially be enhanced through further developments in the enhancing surface/formulation, mathematical deconvolution algorithms, and higher power lasers/more sensitive detectors, respectively.

6.3 SCALE-UP

The SERS method is already “scaled up” for normal operations, although it is notable that a dedicated SERS instrument for explosives is not commercially available. Users must select and purchase the Raman instrument themselves. Furthermore, the spectral deconvolution routines are not automated for this application, and thus require some analyst skill in identifying analytes.

For large projects, where many samples are to be analyzed, labor economies could be realized by processing and analyzing samples in parallel. For example, filtering and sample preconcentration on solid phase adsorbents can be conducted by one analyst using commercial vacuum manifold systems that handle a dozen samples at a time. Parallel analysis would require multiple Raman instruments. The project would need to be very large to carry the capital expense (\$52,000) associated with each additional instrument. However, a single operator could perform approximately four analyses in parallel, saving further on labor costs per sample.

6.4 OTHER SIGNIFICANT OBSERVATIONS

SERS performance has been established for a limited subset of explosives and can therefore be implemented at most contaminated sites. However, the method should also be validated for other explosive analytes to expand its applicability. As the number of validated analytes expands, the need for skilled spectral interpretation or automated deconvolution routines will also increase.

6.5 LESSONS LEARNED

For those interested in implementing the SERS method, an important lesson learned in this project is that a high performance Raman system should be procured from a firm with strong customer support. Lower quality systems are available at commensurately lower expense; however, they will not provide the resolution and sensitivity required and can lead to missing or misidentifying analytes. They are also more prone to malfunction and are generally not field repairable, leading to operator frustration, lost productivity, and increased expense.

Strong customer support will help nonspectroscopists with the technical questions that inevitably arise in the use of the equipment and review of data. Having operators with a background in analytical chemistry/spectroscopy is of distinct advantage. At a minimum, the importance of employing an analyst, skilled in chemical sample handling and preparation, and comfortable with modern analytical instrumentation, cannot be overemphasized given the current state of the art.

6.6 END-USER ISSUES

End users for the SERS technology are on-site environmental services companies currently performing sample collection and field analyses. Discussions with SAIC, IT, and SCS Engineers contractor personnel, as well as USACE oversight personnel, indicate a ready willingness to implement new field screening technologies that overcome the interference problems of existing field methods as long as low $\mu\text{g/L}$ -level sensitivity is available and costs are comparable to or less than colorimetric, immunoassay, and other field techniques. The contractors are ultimately interested in purchasing equipment and supplies and in being trained to perform the analyses, or contracting for SERS analytical services. We have already used the method at former explosive manufacturing plants in the United States and Canada.

6.7 APPROACH TO REGULATORY COMPLIANCE AND ACCEPTANCE.

We have disseminated information to EPA regulators in EPA regions 1, 3, 4, and 10 as well as EPA Headquarters (Office of Solid Waste [OSW]). The SERS method should also be suitable as a Tier 1 single laboratory, single-matrix EPA method as described in the agency's Guide to

Method Flexibility and Approval of EPA Water Methods (Office of Water) and/or as an approved OSW method. Round-robin, interlaboratory validation of the method will be required for approval.

The SERS technology is largely transparent to the public, except to the extent that it lowers monitoring costs, which the citizenry strongly supports. There is no call for direct public participation in the technology.

EPA's recent acceptance of performance-based standards should allow many sites to deploy the technology, using the results of this demonstration to support the use of the method.

This page left blank intentionally.

7.0 REFERENCES

Craig, H., G. Ferguson, A. Markos, A. Kusterbeck, L. Shriver-Lake, T. Jenkins, and P. Thorne. 1996. Field demonstration of on-site analytical methods for TNT and RDX in groundwater. Proceedings, Great Plains Rocky Mountain Hazardous Substance Research Center/Waste Management Education and Research Center Joint Conference on the Environment, pp. 204-219.

Crockett, A.B., T.F. Jenkins, H.D. Craig, and W.E. Sisk. 1998. Overview of on-site analytical methods for explosives in soil. U.S. Army Cold Regions Research and Engineering Laboratory, Special Report 98-4, February 1998.

Crockett, A.B., H.D. Craig, and T. F. Jenkins. 1999. Field sampling and selecting on-site analytical methods for explosives in water. U.S. Environmental Protection Agency, Office of Research and Development, Office of Solid Waste and Emergency Response Report EPA/600/S-99/002.

Jenkins, T.F., P.G. Thorne, and M.E. Walsh. 1994. Field screening method for TNT and RDX in groundwater. U.S. Army Cold Regions Research and Engineering Laboratory, Special Report 94-14, May 1994.

Jenkins, T.F., M.E. Walsh, P.W. Schumacher, and P.G. Thorne. 1995. Development of colorimetric field screening methods for munitions compounds in soil. Proceedings of the Environmental Monitoring and Hazardous Waste Site Remediation Conference, SPIE Vol 2504, pp. 324-333.

Jenkins, T.F., P.G. Thorne, E.A. McCormick, and K.F. Myers. 1995. Preservation of water samples containing nitroaromatics and nitramines. U.S. Army Cold Regions Research and Engineering Laboratory, Special Report 95-16, May 1995.

Keuchel, C., L. Weil, and R. Niessner. 1992. Enzyme linked immunoassay for the determination of 2,4,6-trinitrotoluene and related nitroaromatic compounds. *Analytical Sciences*, 8, pp. 9-12.

Keuchel, C. and R. Niessner. 1994. Rapid field screening test for the determination of 2,4,6-trinitrotoluene in water and soil with immunofiltration. *Fresenius Journal of Analytical Chemistry*, 350, pp. 538-543.

Strategic Diagnostics Inc., Newark, Delaware. RDX and TNT EnSys Soil Test Kits.

Teaney, G.B., R.T. Hudak, and J.M. Melby. 1995. On-site soil and water analysis using D TECH immunoassays for RDX and TNT. Fourth International Symposium on Field Screening Methods for Hazardous Wastes and Toxic Chemicals, p. 965.

U.S. EPA. 2004. Drinking water standards and health advisories. Office of Water Special Publication EPA 822-R-04-005.

Walsh, M.E., T. F. Jenkins, P.S. Schnitker, J.W. Elwell, and M.H. Stutz. 1993. Evaluation of analytical requirements associated with sites potentially contaminated with residues of high explosives. U.S. Army Cold Regions Research and Engineering Laboratory, Special Report 93-5, February 1993.

APPENDIX A

POINTS OF CONTACT

Point of Contact	Organization	Phone Fax E-Mail	Role
Dr. John Haas	ARA 415 Waterman Road South Royalton, VT 05068	(802) 763-8348 (802) 763-8283 Fax jhaas@ara.com	Industrial PI
Dr. Tom Jenkins	CRREL 72 Lyme Road Hanover, NH 03755	(603) 646-4385 (603) 646-4640 Fax tjenkins@crrel.usace.army.mil	Government Lead
R. Doug Webb	USACE 109 St. Josephs Street Mobile, AL 36602	(334) 690-3476 (334) 690-2030 ronald.d.webb@sam.usace.army.mil	ALAAP Government Demo Host
Andrejs Dimbirs, P.G.	USACE P.O. Box 3755 Seattle, WA 98124	(206) 764-6921 (206) 764-3706 Fax andrejs.p.dimbirs@usace.army.mil	UMCD Government Demo Host



ESTCP Program Office

901 North Stuart Street
Suite 303
Arlington, Virginia 22203
(703) 696-2117 (Phone)
(703) 696-2114 (Fax)
e-mail: estcp@estcp.org
www.estcp.org