



**NAVAL
POSTGRADUATE
SCHOOL**

MONTEREY, CALIFORNIA

THESIS

**SPACELIFT RANGE INCREMENTAL MODERNIZATION:
MOVING FROM A STRATEGY OF BACKWARD
COMPATIBILITY**

by

Paul T. Driessen

September 2008

Thesis Co-Advisors:

John S. Osmundson

Thomas V. Huynh

Second Reader:

Jeffrey J. Hargreaves

Approved for public release; distribution is unlimited

THIS PAGE INTENTIONALLY LEFT BLANK

REPORT DOCUMENTATION PAGE			<i>Form Approved OMB No. 0704-0188</i>	
Public reporting burden for this collection of information is estimated to average 1 hour per response, including the time for reviewing instruction, searching existing data sources, gathering and maintaining the data needed, and completing and reviewing the collection of information. Send comments regarding this burden estimate or any other aspect of this collection of information, including suggestions for reducing this burden, to Washington headquarters Services, Directorate for Information Operations and Reports, 1215 Jefferson Davis Highway, Suite 1204, Arlington, VA 22202-4302, and to the Office of Management and Budget, Paperwork Reduction Project (0704-0188) Washington DC 20503.				
1. AGENCY USE ONLY (Leave blank)		2. REPORT DATE September 2008	3. REPORT TYPE AND DATES COVERED Master's Thesis	
4. TITLE AND SUBTITLE Spacelift Range Incremental Modernization: Moving From a Strategy of Backward Compatibility			5. FUNDING NUMBERS	
6. AUTHOR(S) Paul T. Driessen				
7. PERFORMING ORGANIZATION NAME(S) AND ADDRESS(ES) Naval Postgraduate School Monterey, CA 93943-5000			8. PERFORMING ORGANIZATION REPORT NUMBER	
9. SPONSORING /MONITORING AGENCY NAME(S) AND ADDRESS(ES) N/A			10. SPONSORING/MONITORING AGENCY REPORT NUMBER	
11. SUPPLEMENTARY NOTES: The views expressed in this thesis are those of the author and do not reflect the official policy or position of the Department of Defense or the U.S. Government.				
12a. DISTRIBUTION / AVAILABILITY STATEMENT Approved for public release; distribution is unlimited			12b. DISTRIBUTION CODE A	
13. ABSTRACT (maximum 200 words) The intent of this thesis is to gain insight into launch and test range requirements in order to determine transitional architectures by using a systems engineering methodology developed at the Naval Postgraduate School. The range is a weapon system that has many characteristics of an automated information system with each function having its own timing and bandwidth requirements. The sensors considered are those left after the range begins using GPS metric tracking for all launch vehicles. The analysis focuses on comparing the use of current data formats to an Internet Protocol version 6 (IPv6) standard by considering data availability and timeliness as design parameters. Sensors should be compatible with the data network rather than with legacy formats since data is not transported in the legacy formats. Devices requiring a legacy format need a converter to consume data from the network. The analysis was an accounting of throughput required at various nodes on the data network, and estimates of data latency along critical data links. The conclusion is that the current range architecture is able to support GPS metric tracking and that an IPv6 network is a viable option that moves the range toward compliance with the Operational Requirements Document.				
14. SUBJECT TERMS Spacelift Range, System of Systems Engineering, Systems Engineering			15. NUMBER OF PAGES 83	
			16. PRICE CODE	
17. SECURITY CLASSIFICATION OF REPORT Unclassified	18. SECURITY CLASSIFICATION OF THIS PAGE Unclassified	19. SECURITY CLASSIFICATION OF ABSTRACT Unclassified	20. LIMITATION OF ABSTRACT UU	

THIS PAGE INTENTIONALLY LEFT BLANK

Approved for public release; distribution is unlimited

**SPACELIFT RANGE INCREMENTAL MODERNIZATION:
MOVING FROM A STRATEGY OF BACKWARD COMPATIBILITY**

Paul T. Driessen
Lieutenant Colonel, United States Air Force
M.S. Mechanical Engineering, New Mexico State University, 1994

Submitted in partial fulfillment of the
requirements for the degree of

MASTER OF SCIENCE IN SYSTEMS ENGINEERING

from the

NAVAL POSTGRADUATE SCHOOL
September 2008

Author: Paul T. Driessen

Approved by: John S. Osmundson
Thesis Co-Advisor

Thomas V. Huynh
Thesis Co-Advisor

Jeffrey J. Hargreaves
Second Reader

David H. Olwell
Chairman, Department of Systems Engineering

THIS PAGE INTENTIONALLY LEFT BLANK

ABSTRACT

The intent of this thesis is to gain insight into launch and test range requirements in order to determine transitional architectures by using a systems engineering methodology developed at the Naval Postgraduate School. The range is a weapon system that has many characteristics of an automated information system with each function having its own timing and bandwidth requirements. The sensors considered are those left after the range begins using GPS metric tracking for all launch vehicles. The analysis focuses on comparing the use of current data formats to an Internet Protocol version 6 (IPv6) standard by considering data availability and timeliness as design parameters. Sensors should be compatible with the data network rather than with legacy formats since data is not transported in the legacy formats. Devices requiring a legacy format need a converter to consume data from the network. The analysis is an accounting of throughput required at various nodes on the data network and estimates of data latency along critical data links. The conclusion is that the current range architecture is able to support GPS metric tracking and that an IPv6 network is a viable option that moves the range toward compliance with the Operational Requirements Document.

THIS PAGE INTENTIONALLY LEFT BLANK

TABLE OF CONTENTS

I.	INTRODUCTION.....	1
	A. BACKGROUND	1
	1. Eastern Range	1
	2. Western Range	2
	3. Future Range Architectural Planning	4
	B. PURPOSE.....	4
	C. RESEARCH QUESTIONS.....	5
	D. BENEFITS OF STUDY.....	5
	E. SCOPE AND METHODOLOGY	5
	F. ORGANIZATION AND SUMMARY OF STUDY	6
	1. Background Information.....	6
	2. Analysis and Results	6
	3. Conclusions and Recommendations.....	7
II.	RESEARCH	9
	A. INTRODUCTION.....	9
	B. METHODOLOGY	9
	C. RESEARCH	9
	1. Systems Engineering.....	9
	2. Range Requirements.....	10
	3. Range Architecture.....	10
	<i>a. Range Sensors</i>	<i>12</i>
	<i>b. Range Network.....</i>	<i>15</i>
	<i>c. Range Safety Systems.....</i>	<i>17</i>
	4. Eastern Range Operational Configurations.....	21
	5. Communications Networking	21
	<i>a. Publish/Subscribe Systems</i>	<i>21</i>
	<i>b. Data Distribution Service for Real-time Systems</i>	<i>23</i>
	D. SUMMARY	23
III.	ANALYSIS AND RESULTS	25
	A. INTRODUCTION.....	25
	B. ANALYSIS	25
	1. Development of System of Systems Scenarios and Operational Architectures	25
	<i>a. Conceptual Architectures</i>	<i>26</i>
	<i>b. Operational Scenario</i>	<i>28</i>
	<i>c. Range Network.....</i>	<i>29</i>
	<i>d. Alternative 1: Legacy Network Model Architecture</i>	<i>30</i>
	<i>e. Alternative 2: Modernized Network Model Architecture</i>	<i>31</i>
	2. Identification of System Threads.....	31
	3. Representation of Operational Architectures in a Unified Modeling Language (UML)-Like Format	33

4.	Identification of System of Systems Design Parameters and Factor Levels	40
<i>a.</i>	<i>Timeliness</i>	40
<i>b.</i>	<i>Reliability</i>	40
<i>c.</i>	<i>Availability</i>	41
5.	Transformation of UML-like Format Representation into Executable Models	42
<i>a.</i>	<i>Availability</i>	42
<i>b.</i>	<i>Timeliness</i>	45
<i>c.</i>	<i>Timelines: Backward Compatibility</i>	49
6.	Application of Design of Experiments.....	49
7.	Modeling and Analysis of Results.....	50
<i>a.</i>	<i>Availability</i>	52
<i>b.</i>	<i>Timeliness</i>	54
C.	RESULTS	56
D.	SUMMARY	57
IV.	CONCLUSIONS AND RECOMMENDATIONS.....	59
A.	CONCLUSIONS	59
B.	RECOMMENDATIONS.....	60
C.	AREAS OF FURTHER RESEARCH.....	60
	LIST OF REFERENCES	63
	INITIAL DISTRIBUTION LIST	65

LIST OF FIGURES

Figure 1.	Eastern Range (Headquarters Air Force Space Command, 2007).....	2
Figure 2.	Western Range (Headquarters Air Force Space Command, 2007)	3
Figure 3.	Eastern Range Core Network (Fig. 1-1 in Computer Sciences Raytheon, 2008)	16
Figure 4.	Conceptual View of Range Architecture (Slide 13, Shappell, 2008)	27
Figure 5.	Conceptual Architecture	27
Figure 6.	Hub and Spoke Sensor Network	29
Figure 7.	Model Architecture	31
Figure 8.	Non-nominal Launch Event Timing	35
Figure 9.	Representation of Operational Scenario	36
Figure 10.	Model Representation of Range Network.....	43
Figure 11.	Basic Data Flow Model	44
Figure 12.	Basic Flow Model	45
Figure 13.	Landline Path Model.....	47
Figure 14.	Microwave Path Model.....	48
Figure 15.	Core Node Connected to CTPS	53
Figure 16.	Data Timeliness Model Using Commercial Landlines from JDMTA to the Core Network.....	55
Figure 17.	Data Timeliness Model Using the Microwave Radio System from JDMTA to the Core Network.....	56

THIS PAGE INTENTIONALLY LEFT BLANK

LIST OF TABLES

Table 1.	Eastern Range Assets Under Various Plans.....	12
Table 2.	Connection Speeds (Table 3.1-1 in Computer Sciences Raytheon, 2008)	16
Table 3.	FOV1 Data Inputs	19
Table 4.	Time Span (in seconds) of Missile Visibility from Various Sights	30
Table 5.	Edge Device Delay Times from Interfacing with Various Circuit Types	46
Table 6.	Network Traffic that Passes Through the Network Nodes	51
Table 7.	Comparison of Bandwidth Consumed Under Different Data Structures.....	52
Table 8.	Network Traffic Put On or Removed from the Core Through Various Nodes (Note that the capacity to add and remove data is 622 Mbps).....	54

THIS PAGE INTENTIONALLY LEFT BLANK

ACRONYMS AND ABBREVIATIONS

30 SW	30th Space Wing
45 SW	45th Space Wing
ADP	Acquisition Data Processor
AFSPC	Air Force Space Command
AFTS	Autonomous Flight Termination Systems
AIS	Automated Information System
AIS	Automated Information System
ATM	Asynchronous Transfer Mode
C3T	Command, Control, Communication and Timing
C4ISR	Command, Control, Communications, Computer, Intelligence, Surveillance, and Reconnaissance
CCAFS	Cape Canaveral Air Force Station
CTPS	Centralized Telemetry Processing System
DoD	Department of Defense
DoDAF	Department of Defense Architecture Framework
DRSD	Distributed Range Safety Display
DSSS	Designate Source Select Switch
ER	Eastern Range
FOV1	Flight Operations Version 1
FRAT	Future Range Architecture Team
GIG	Global Information Grid
GPS	Global Positioning System
HDD	High Density Data
IGS	Inertial Guidance System
IIP	Instantaneous Impact Point
IMUX	Inverse Multiplexers
IP	Internet Protocol
IPv6	Internet Protocol version 6
JDMTA	Jonathan Dickinson Missile Tracking Annex
KSC	Kennedy Space Center
LET	Launch Enterprise Team
LO	Liftoff
LTRS	Launch and Test Range System
LV	Launch vehicle
MCD	Mission Continuation Display
MDA	Missile Defense Agency
MFCO	Missile Flight Control Officer
MIPIR	Missile Precision Instrumentation Radars
MIT-LL	Massachusetts Institute of Technology Lincoln Laboratory
MOTR	Multiple Object Tracking Radar
MRTFB	Major Range and Test Facility Base
NASA	National Aeronautics and Space Administration

NOAA	National Oceanic and Atmospheric Administration
ORD	Operational Requirements Document
PAFB	Patrick Air Force Base
QoS	Quality of Service
RASCAD	Range Safety Control and Display
ROCC	Range Operations Control Center
ROSA	Radar Open Systems Architecture
SMC	Space Missile Systems Center
SPOF	Single-point-of-failure
SSN	Space Surveillance Network
SV	Space vehicle
SWTB	Southwest Terminal Building
TDM	Time Division Multiplexing
TGRS	Translated GPS Receiver System
UML	Unified Modeling Language
UML	Unified Modeling Language
VAFB	Vandenberg Air Force Base
WANIU	Wide Area Network Interface Units
WCOOA	West Coast Offshore Operating Area
WR	Western Range

ACKNOWLEDGMENTS

The author wishes to acknowledge the insights the Future Range Architecture Team (FRAT) offered that stand regardless of the range footprint. Besides what they offered the range, members of the FRAT have been very generous with their time and insights. Thank you Mike Gorlick, George Thomas, Brian Laird, and Richard Lamb.

The range is far better off for having the Massachusetts Institute of Technology Lincoln Laboratory (MIT-LL) involved with the radar subsystem. There are a number of other areas that would benefit from their involvement. This thesis certainly benefited from the involvement of Jeffery Hargreaves from MIT-LL.

The author also wishes to acknowledge the role of the engineers, operators and everyone else involved in making the range work. Many of them have been very generous with their time and insights. Among them are Cheryl Lee Emard, Joe Gillis, Maria Soto-Yodonis, Lee Smith, Harry Morton, David Bryant, Mike Russick, and Jeff Richards.

One more acknowledgment is in order. That would be for the support and encouragement from the author's fellow students of PD21 cohort 7.

Thank you all.

THIS PAGE INTENTIONALLY LEFT BLANK

I. INTRODUCTION

A. BACKGROUND

The United States Air Force is responsible for operating and sustaining the nation's Spacelift Ranges. They are the Eastern Range (ER) in Florida with launch complexes at Cape Canaveral and Kennedy Space Center, and the Western Range (WR) with launch complexes at Vandenberg Air Force Base. Together, the ER and WR comprise the current Launch and Test Range System (LTRS).

The Eastern Range is operated by the Air Force's 45th Space Wing (45 SW), and the 30th Space Wing (30 SW) operates the Western Range. Space Missile Systems Center (SMC) is responsible for both sustainment and new acquisitions. These responsibilities have been assigned to the Launch and Ranges Range Group under the Launch and Range Systems Wing.

The primary mission of the LTRS is to support both routine and responsive spacelift for DoD, other US government agencies (NASA, NOAA and intelligence community) and commercial interests. The secondary and tertiary missions are Test and Evaluation, and supporting the Space Surveillance Network (SSN) respectively.

1. Eastern Range

The 45th Space Wing, headquartered at Patrick Air Force Base (PAFB), conducts spacelift and missile test operations at the ER on the central east coast of Florida (see Figure 1).

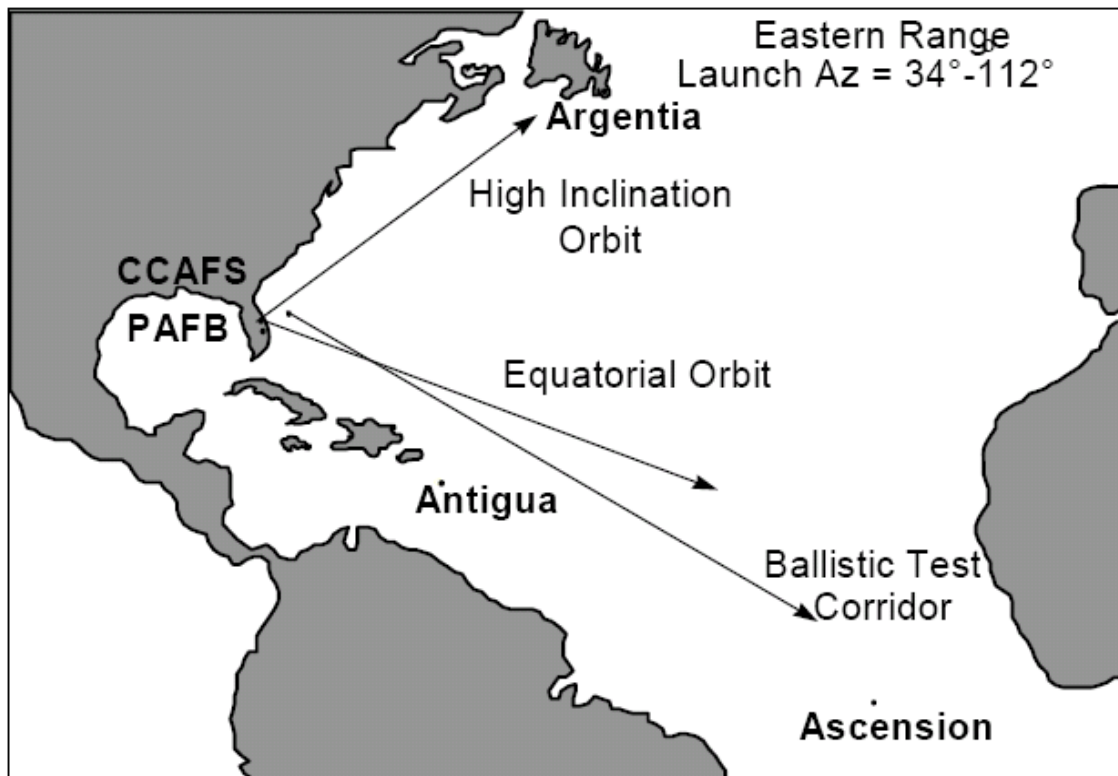

Figure 1. Eastern Range (Headquarters Air Force Space Command, 2007)

ER instrumentation sites are located at NASA’s Kennedy Space Center (KSC), Cape Canaveral Air Force Station (CCAFS), PAFB, Melbourne Beach Optical Tracking Annex, Malabar Annex, Jonathan Dickinson Missile Tracking Annex (JDMTA), Antigua Air Station in the eastern Caribbean Sea, and Ascension Auxiliary Airfield in the South Atlantic Ocean. For North Easterly space launches, the ER extends north to New Hampshire Tracking Station and Argentia in Newfoundland, Canada, and includes a midpoint location at Wallops Islands, Virginia (NASA facility). Launch sites on KSC and CCAFS are capable of supporting most launch azimuths from 34° to 112 ° with some excluded for safety restrictions.

2. Western Range

Headquartered at Vandenberg Air Force Base (VAFB), the 30th Space Wing conducts spacelift and missile test launches at the WR on the central coast of California (Figure 2).

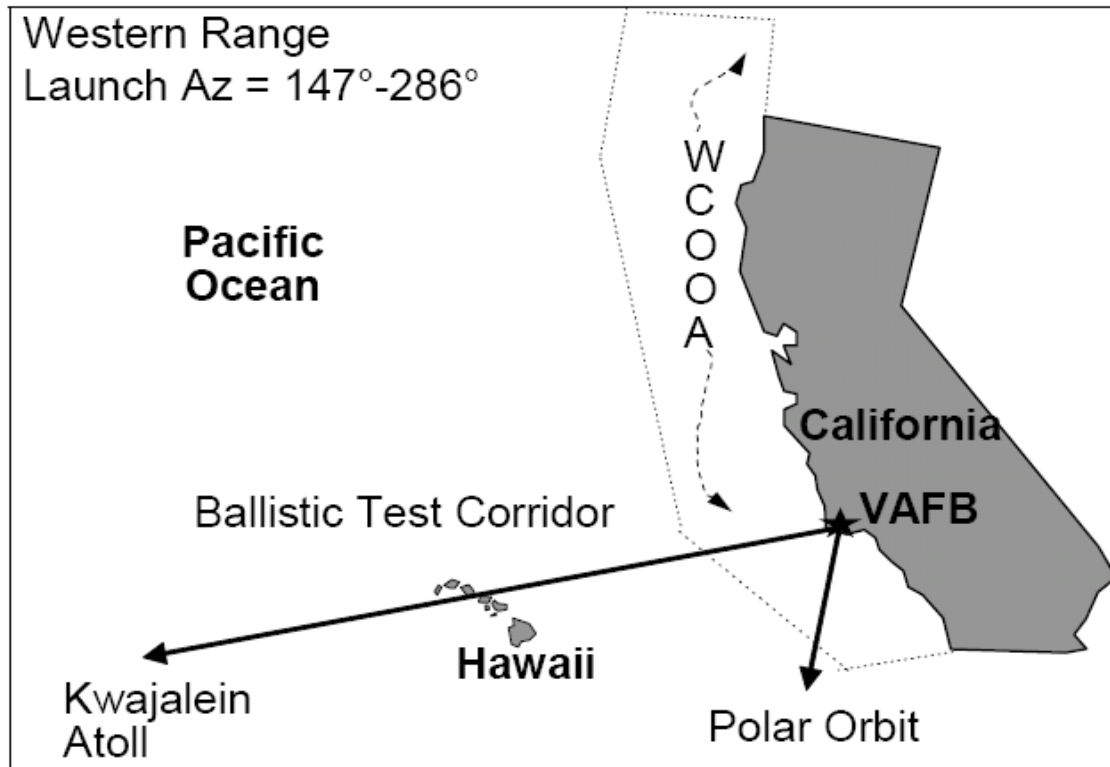

Figure 2. Western Range (Headquarters Air Force Space Command, 2007)

WR instrumentation sites are located along the Pacific coast at Pillar Point Air Force Station, VAFB, Anderson Peak, Santa Ynez Peak, Laguna Peak, and Point Mugu. The WR supports southern trajectory space launches capable of achieving polar orbits. Launch sites on VAFB are capable of supporting launch azimuths from 147° to 286°. In conjunction with other Major Range and Test Facility Base (MRTFB) activities, the WR provides continuous instrumentation coverage for ballistic missile test launches into target areas in the Pacific Ocean. Additionally, the WR provides operational support for the West Coast Offshore Operating Area (WCOOA), creating an aeronautical, and guided and unguided missile test corridor along the Pacific coast from the Mexican to the Canadian borders. The WR supports satellite launches into polar orbits, intercontinental ballistic missile tests, Missile Defense Agency (MDA) activities, and aeronautical tests.

3. Future Range Architectural Planning

The Future Range Architecture Team (FRAT) was assembled to provide a range roadmap that moves from the current range architecture to a vision for 2020. The team included representatives from Headquarters Air Force Space Command (operations and requirements directorates), Launch and Ranges Systems Wing, 30th Space Wing, 45th Space Wing, Aerospace Corporation, and ENSCO.

The lynchpin of the FRAT's proposed architecture is a net-ready infrastructure built on the Internet Protocol version 6 (IPv6) standard, which is interoperable with the DoD information sharing environment known as the Global Information Grid (GIG). This would replace the current Cellworx® core with a modern and sustainable communications network.

Since the time the FRAT developed their proposal, considerable budget cuts were projected. The commander of Air Force Space Command charged the Launch Enterprise Team (LET) with finding potential savings in the launch enterprise. Since then, the vision of the range architecture has been the subject of vigorous debate.

B. PURPOSE

The intent of this thesis is to gain insight into LTRS requirements for determining reasonable transitional architectures.

Currently the Spacelift Ranges use a strategy of acquiring modern instrumentation and making it backward compatible to the current range infrastructure. This approach was a driver in the cost and complexity of employing the Massachusetts Institute of Technology Lincoln Laboratory (MIT-LL) developed radar known by the acronym ROSA, which stands for Radar Open Systems Architecture. Bringing ROSA to the Spacelift Ranges required elaborate interfacing to slow the data and conform to the legacy data frames in order to interface with the current range infrastructure. Other instrumentation modernization efforts are underway and they will likely have a number of backward compatibility requirements. Determining how to break out of the backward compatibility mode gives rise to the research questions posed in this thesis.

Since the range needs to continue to support operations during the transition, there may be interim hybrid configurations used during the evolution. Perhaps a hybrid range consisting of various sub-networks of net-ready sensors made backward compatible as a group is more effective. Perhaps a modernized range will be built alongside the legacy range with sensors feeding both the legacy and modern networks. After a series of dual mode operations the legacy network can be turned off.

C. RESEARCH QUESTIONS

Question 1: Should the Spacelift Ranges migrate their data networks to an IPv6 standard as proposed by the Future Range Architecture Team?

Question 2: In modernizing the range data network, is it more advantageous to make legacy components forward compatible or to make modern components backward compatible?

D. BENEFITS OF STUDY

This study proposes criteria and methodology to evaluate different range network configurations and data flow schemes. The criteria are data availability, which is whether the network has the capacity to transport the required data, and timeliness, which is whether the data transport is done within the allowable time. The method for evaluating availability is to determine the required volume of data and compare it to the capacity of the network switches and data links. The methodology for evaluating timeliness is to determine the latency of various data links by adding the latency of each step of the data transport process. The intended benefit is to give decision makers a framework for considering the merits of projects that evolve the range to the planned future architecture.

E. SCOPE AND METHODOLOGY

This thesis proposes interim configurations that the Eastern Range might assume during its evolution. The candidate interim configurations are consistent with the visions of the LET in that the range footprint reflects its plan with different networking schemes.

The candidate configurations are retaining the current network or upgrading it according to the FRAT plan. Operational scenarios are identified and the candidate configurations are evaluated in terms of system design parameters.

F. ORGANIZATION AND SUMMARY OF STUDY

1. Background Information

This thesis begins with a discussion of the strategy for gathering background information for the analysis. Broad topic areas are identified along with a discussion of potential sources of information. The basic topic areas are 1) systems engineering methodology, 2) range requirements, 3) Eastern Range architecture, 4) Eastern Range operational configurations, and 5) communications networks. The strategy discussion is followed by a summary of the information gathered. The information is grouped in the same topic areas.

2. Analysis and Results

The analysis of the candidate configurations and the results are organized as a discussion of how each step of the system engineering methodology is applied to studying the Eastern Range. The analysis focuses on comparing the current network structure to a proposed network based on an IPv6 standard. The design parameters are availability and timeliness. Both of these are judged from a range safety perspective.

Availability is considered in terms of the network capacity to move all of the required data. A throughput model is used to determine how much bandwidth is required. Timeliness requirements are established to meet the range safety requirements. Timeliness is evaluated by considering the data latency introduced as the data flows through the network. The results of this analysis are considered in terms of how range systems are made to be interoperable with the network and how that interoperability might be achieved.

3. Conclusions and Recommendations

The range is generally considered a weapon system sensor network and is often viewed as a hub and spokes topology with an operations center at the hub and the sensors on the spokes. Another point of view useful for determining range functional requirements is one that considers the range as an Automated Information System (AIS) where data comes on to a network and consumers access it. This viewpoint focuses on the core network, which would be the hub from the sensor net point of view. Both viewpoints reflect functions the range needs to perform. Each function has its own timing and availability (bandwidth) requirements that converge on the core network; the data network thus needs to be the focus of architectural decisions. In particular, the sensor interfaces need to be defined for compatibility with the data network rather than with legacy data formats, which are incompatible with the data network.

The current range network has the bandwidth for the network traffic required to function as a sensor network and as an Automated Information System. The limiting factor for the network is the data link to JDMTA. This link is especially important because all GPS metric tracking data is processed at JDMTA. The GPS data is contained in the telemetry stream. At this point, the telemetry stream needs to be divided, so only the portion carrying the GPS data is sent for processing at JDMTA. The commercial leased lines do not have the capacity to handle the entire telemetry stream. Another network traffic flow that is worth considering is the data link to the telemetry site TEL IV. TEL IV is where the telemetry streams are evaluated to determine which stream to provide to the range customer. Both the current network and an IPv6 based network can meet the timeliness requirements for range safety. The biggest source of data latency comes from packaging data into cells for transport on the network. The IPv6 network would require data to be sent in IP packets. The time needed for either operation is dependent on the rate data flows into the device that packages it because the cells (or packets) cannot be assembled until the entire data frame is received. This makes adherence to legacy data standards (240-bit data frames transported at 2.4 or 4.8 Kbps) a significant source of latency.

Sensors should be built to be compatible with the data network rather than with the data rate and format of the device consuming the data. Since data is not transported on the network in the legacy data formats, any device that requires a legacy data format must have a converter to consume data from the network. Requiring new sensors to output a legacy data format means that output has to be converted to a cell (or packet) for it to be sent on the data network. If the sensor could have output data in a form compatible with the network, the steps required to produce the legacy format add unnecessary complexity and latency.

The current range architecture seems able to support a move to GPS metric tracking. Additionally, this analysis concludes that an IPv6 based range data network is a viable option that moves the range toward compliance with the Operational Requirements Document (ORD). However, supportability and interoperability are significant factors in choosing an architecture. Consideration of those factors is beyond the scope of this thesis.

II. RESEARCH

A. INTRODUCTION

Learning about the Spacelift Ranges proved to require a great deal of research. Studying a few documents led to asking people questions, which in turn generated referrals to various experts. The experts often recommended studying other documents, drawing, and handbooks, which lead to more questions and so on.

Creating a system of systems out of the range assets is largely a matter of networking. The range network is the focus of this analysis.

B. METHODOLOGY

The research methodology is to review published work that describes and discusses application of a systems engineering methodology developed at the Naval Postgraduate School (Osmundson & Huynh, 2005). The next area of investigation is the range requirements. Since the range is an Air Force acquisitions program, requirements are formally documented. Interviews with range engineers and operators give additional insight into the requirements. These sources and range operational capability documents provide information on the current range architectures. Current thinking on the future of the range architecture is revealed in presentations given by various groups working in Air Force Space Command. Interviews are another valuable source of information.

Another research objective is to gain an understanding of information networks. This is done by reviewing journal articles, range operator training materials, industry standards, and through conducting interviews.

C. RESEARCH

1. Systems Engineering

A practical method of analyzing a system of systems is espoused in (Osmundson & Huynh, 2005). This method applies effectively to the Spacelift Ranges since it is

concerned with systems that have been developed and still function as standalone systems. It is well suited to systems such as the Spacelift Ranges whose success is dependent on process timeliness. The method involves a sequence of analyses, modeling, and simulations. The seven steps of the method are as follows:

- Development of system of systems scenarios and operational architectures
- Identification of system of systems threads
- Representation of operational architectures in a unified modeling language (UML)-like format
- Identification of systems of systems design parameters and factor levels
- Transformation of UML-like format representation into executable models
- Application of design of experiments
- Simulation runs and analysis of results

2. Range Requirements

The range requirements are captured in the Operational Requirements Document (ORD) (Headquarters Air Force Space Command, DRDS, 2003). Particular attention is given to interoperability as discussed in Section 1.4.3 Command, Control, Communications, Computer, Intelligence, Surveillance, and Reconnaissance (C4ISR) Operational Concept. The ORD offers an operational view 1 (OV-1) of the LTRS listing the wide variety of agencies and supporting ranges that need to interface with the Spacelift Ranges and the connections that join the range subsystems together to create a system of systems. The ORD, again from Section 1.4.3.3, specifies that the LTRS must have interfaces for connectivity to digital and analog information links, satellite and voice communications circuits. Additionally, the LTRS must operate within the DoD information sharing environment known as the Global Information Grid (GIG).

3. Range Architecture

Deliberations on the range architecture seem to center on the number and placement of what this analysis called the end items, which are the sensors necessary to perform the range tracking functions. The evolution of the range architecture is also discussed in terms of two maturing concepts that may change the way range functionality is achieved.

Starting with a review of the range function, the FRAT (FRAT, 2007) identifies the required functionality as:

- **Flight Control** (command destruct, flight operations, flight analysis, vehicle control)
- **Space vehicle (SV)/launch vehicle (LV) health and status** (performance, telemetry)
- **Tracking** (debris, launch vehicle position, staging events)
- **Imaging** (documentary—media, public affairs, engineering analysis, event reconstruction)
- **Command, Control, Communication and Timing-C3T** (voice, data, video, timing, range operations management)
- **Data Handling** (data products, planning and scheduling)
- **Area Surveillance** (detection & assessment of air, sea, and rail encroachments)
- **Weather** (observation, analysis, forecasting)

The functions whose evolution will most impact the range footprint (end item assets) are Tracking and Flight Control, particularly the command destruct part of Flight Control.

In the near future, GPS metric tracking will be utilized on a number of launch vehicles. Currently the GPS data is received on a telemetry stream, and so is the Inertial Guidance System (IGS) data. They fulfill the requirement of having two independent sources of metric tracking data. Radar and optics (on the Eastern Range at least) are also viable sources of metric track data. As GPS tracking is fully implemented, radar and optics will no longer be considered range safety mandatory and will instead provide imaging data and back up tracking data, as well as debris tracking.

Another concept that will shape the range is the evolution of Autonomous Flight Termination Systems (AFTS). Flight termination is currently done with a person in the loop. The tracking data is displayed for a person to consider in determining whether to command the vehicle to destruct. The commands are sent using ground based

antennas at a variety of points along the range. When AFTS are used on every rocket launched, the range can divest the ground based command systems and possibly the systems that generate metric tracking data.

a. Range Sensors

The number and the placement of range sensors are often the focus of discussion about the range architecture. A list of the current range assets is shown in Table 1, which depicts a distinction between enabling equipment necessary for end items (sensors) to operate as part of the range system. For example, the radars and telemetry sites are end items that directly result in range capability to cover a particular mission. The communications infrastructure and items like voice communications are all necessary, irrespective of the number of end items because they enable the subsystems to be joined into the range system. Table 1 shows the FRAT and LET assets considered necessary while working under the assumption that GPS metric tracking would replace radar as a range safety metric tracking source. The LET went on to develop preliminary planning concepts for a range using AFTS.

In Table 1 ‘X’ indicates equipment (rows) used in the given plan (columns) and ‘D’ denotes assets to be divested. Enabling equipment lines are grey.

Table 1. Eastern Range Assets Under Various Plans

		Current		FRA T block 1 End Item	LET Pre GPS	LET GPS	AFTS used End Item
		Enabler	End Item				
	ADD GPS metric tracking			X		X	X
CCAFS/KSC/PAFB/PDL	1.16		X	D	X	D	
	19.39 (MOTR)		X	X	D	D	
	19.17		X	D	X	D	
	19.14		X	X	D	D	
	0.14		X	X	X	X	
	SPARC	X					
	FCA Control	X					
	FCA Van #1,2	X					
	TAA-3c		X	X	X	X	X

		Current		FRA T block 1 End Item	LET Pre GPS	LET GPS	AFTS used End Item
		Enabler	End Item	End Item	Pre GPS	GPS	End Item
	TAA-24A		X	X	X	X	X
	AFSCN Data Distribution	X					
	Data Acquisition and Processing	X					
	Display	X					
	Record	X					
	Separation	X					
	CTPS	X					
	TRG	X					
	9M-1,2	X					
	4.3M	X					
	ACME	X					
	CAPE 1B		X	X	X	X	D
	CAPE 1A		X	X	X	X	D
	CCRS	X					
	Analog Voice	X					
	Cable Plant and Conditioning	X					
	Commercial Leased Lines	X					
	Digital Voice-XY	X					
	NASCOM	X					
	Wideband	X					
	CORE	X					
	Data Transmission	X					
	Digital Voice	X					
	Intelsat SATCOM	X					
	M365 INMARSAT	X					
	Microwave	X					
	TMS	X					
	AMP S-A,B	X					
	MSC	X					
	DBS	X					
	DRSD	X					
	FOV1-A,B	X					
	RSAS	X					
	Count, Timing, and Control	X					
Optics	ATOTS 1,2		X	X	X	X	X
	MIGOR		X	X	X	X	X
	CINE 401-403		X	D	X	D	D
	CINE 404-407		X	D	D	D	D
	Playalinda DOAMS		X	X	X	X	X
	PAFB DOAMS		X	X	X	X	X
JDT MA	28.14		X	Elimi nate	D	D	D
	TAA-50-1		X		X	X	moved

		Current		FRA T block 1 End Item	LET Pre GPS	LET GPS	AFTS used End Item
		Enabler	End Item				
							CCAFS
	TAA-50-2		X		X	X	moved CCAFS
	TAA-50-3		X		X	X	Eliminate
	TAA-50-4		X		X	X	
	ACME	X					
	COMMAND		X		X	X	
	Cable Plant and Conditioning	X					
	CORE	X					
	Data Transmission	X					
	Microwave	X					
	TMS	X					
	TGRS (GPS tracking)			X		X	X
Count and Timing	X						
Antigua/St. Thomas	91.14		X	D	D	D	D
	91.134		X	D	D	D	D
	TAA-3C		X	X	X	X	X
	TAA-8A		X	X	X	X	X
	ACME	X					
	COMMAND		X	X	D	D	D
	Cable Plant and Conditioning	X					
	CORE	X					
	Data Transmission	X					
	Digital Voice	X					
	Intelsat SATCOM	X					
	TMS	X					
Count and Timing	X						
Argentina	53.17		X	Support with mobiles	Support with mobiles	Support with mobiles	Eliminate
	ACME	X					
	COMMAND		X				
	Data Transmission	X					
	Cable Plant and Conditioning	X					
	TMS	X					
Station Count and Timing	X						
ASC	12.18		X	D	D	D	D
	12.15		X	X	X	X	X
	TAA-3C-1		X	D	D	D	D
	TAA-3C-2		X	D	D	D	D
	Station Count and Timing	X					

b. Range Network

The FRAT plan for the range architecture looks beyond the end item assets to focus on the data network. It proposes an architecture built on an IPv6 network ring that would allow the range to be DoD GIG compliant. GIG compliance is an ORD requirement found in Section 1.4.3.3. The FRAT presents GIG compliance as one of the pillars of their Block 1 architecture. The five pillars are: 1) comply with the DoD Joint Technical Architecture by using IPv6, 2) become compatible with the GIG, 3) use cluster computing, 4) have massive storage for high bandwidth digital imaging, and 5) provide new software based telemetry receivers and recorders (Slide 20, FRAT, 2007).

The legacy communications network is largely based on Cellworx® switches which are designed for use in an asynchronous transfer mode (ATM); however, the network is setup for Time Division Multiplexing (TDM) (Bryant, 2008) using circuits that are static during a launch operation. The Eastern Range network uses a ring topology connecting four primary facilities. The facilities are the Range Operations Control Center (ROCC), XY Facility, Southwest Terminal Building (SWTB), and the East Terminal Building (ETB).

The core itself is shown as Ring 1 and Ring 2 in the CCAFS CORE – Data Flow illustration that is presented in the Eastern Range Instrumentation Handbook (Computer Sciences Raytheon, 2008), shown in Figure 3. Table 2 explains the path speeds (Computer Sciences Raytheon, 2008).

CCAFS CORE – Data Flow

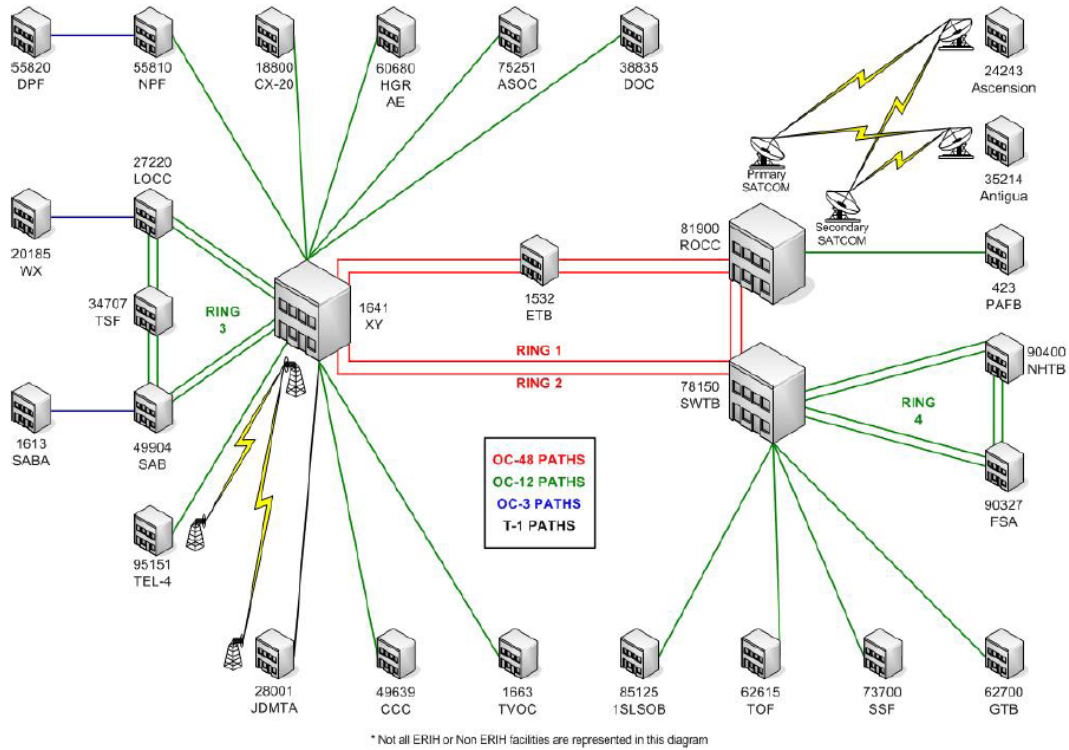

Figure 3. Eastern Range Core Network (Fig. 1-1 in Computer Sciences Raytheon, 2008)

Table 2. Connection Speeds (Table 3.1-1 in Computer Sciences Raytheon, 2008)

SIGNAL LEVEL	DATA RATE (Mbps)	COMMENT
DS-0	0.064	Standard voice channel
DS-1 or T-1	1.544	24 Standard voice channels
DS-3	44.736	28 DS-1s
STS-1 (OC-1)	51.84	DS-3 with ATM/SONET overhead
OC-3	155	3 OC-1s
OC-12	622	12 OC-1s
OC-48	2488	48 OC-1s

The core consists of five subsystems: 1) ATM Core, 2) Core Access Concentrators 3) Core Data Subsystem, 4) Core Video Subsystem, and 5) Inverse Multiplexers (IMUX) (Computer Sciences Raytheon, 2008).

The core rings are designed to be fault tolerant in that they react to a node failure by routing the network traffic around the ring in the opposite directions. The only capability lost is the ability to add or remove data from the core via the failed node. The Core Access Concentrators are located at each of the nodes to adapt a variety of non-ATM traffic to an ATM format for transfer onto the core rings. The Core Data subsystem serves as an interface for handling telemetry data. The Core Video subsystem is capable of digitizing and managing videos using the core for transport to end users. The IMUX subsystem provides the interface between the ROCC Wide Area Network Interface Units (WANIU) and the JDMTA WANIU.

The Eastern Range Instrumentation Handbook includes a section on limitations of the core. One limitation is that the data latency for the 2.4 Kbps synchronous circuit is approximately 60 milliseconds. Its impact is that the ATM core cannot be used to directly transport this data, so it must be aggregated into cells compatible with T-1 circuits for transport. There is also significant latency in the video system. For the 5 MHz bandwidth rate the latency is 1244 milliseconds, for 10 MHz it is 827 milliseconds, and at 15 MHz the latency is 717 milliseconds (Computer Sciences Raytheon, 2008).

c. Range Safety Systems

The range safety systems include the system that processes and displays metric tracking and telemetry borne vehicle performance data. They also provide target acquisition data to the command, telemetry and radar systems. The system that provides for termination of an errant vehicle is also a range safety system.

Flight Operations Version 1 (FOV1) is the primary system that processes trajectory source data. Two independent FOV1 systems, designated FOV1-A and FOV1-B, are used. A tertiary processor, the Distributed Range Safety Display (DRSD) system is included to mitigate the risk of a latent software defect in FOV1-A and FOV1-B, which

run the same software. These systems generate flight path, predicted Instantaneous Impact Point (IIP) displays, and other displays that are needed to determine the risk of violating pre-defined mission rules.

The FOV1-A system also has an additional Mission Continuation Display (MCD) to monitor vehicle performance and provide an independent, telemetry only IIP display. The MCD design and programming language is completely different from the two FOV1 systems as a safe guard against software Single Points of Failure (SPOF).

The FOV1-A, FOV1-B, and DRSD systems provide designate data on the High Density Data (HDD) lines to instrumentation sites via the Data Buffer System. The Designate Source Select Switch (DSSS) is used to assign which system's HDD output to the remote sites. That decision is made by the Acquisition Data Processor (ADP) operator.

Data frames are synchronized before entering FOV1 by buffering them in 100-millisecond intervals (Thomas, 2008). Radar and optics data can be up to one second old and telemetry data can be up to 1.2 seconds old (Richards, 2008). Radar and optics data frames include a data bit known as the "track-bit." Additionally a quality-bit, known as a "Q bit," is available to indicate that the track is considered to be of good quality. FOV1 can use data from a source irrespective of the Q-bit, but generally will not use data if the Q-bit is not set. Telemetry data quality is judged with frame synchronization indicators. The FOV1 display operator has the option of rejecting a data source. This might be done if the data seems to be "noisy" or if the sensor is under test and evaluation (Thomas, 2008).

FOV1 inputs are tabulated in Table 3. Different sensors use different coordinate systems. Optic trackers only measure angles, so several trackers are needed to generate a position solution by triangulating. The site IDs give the FOV1 reference points for coordinate transformations.

Table 3. FOV1 Data Inputs

FOV1 Data Inputs	
Radar	E, F, G, E', F', G', time, site ID, Q-bit, Track-bit
Optics	Azimuth, elevation, time, site ID, Q-bit, Track-bit
Inertial Guidance System (IGS)	X, Y, Z, X', Y', Z', time, site ID, Command receiver status
GPS by Telemetry	E, F, G, E', F', G', time

The EFG means Earth Fixed Geodetic, which uses a Cartesian coordinate system with its origin at the center of the earth. The axes are labeled E, F, and G and the velocity component in the direction of those axes are labeled E', F', and G', respectively. X, Y, Z are the axes of a Cartesian coordinate system whose origin is established as the IGS position on the pad when the gyroscopes are uncaged (Thomas, 2008).

FOV1 can be configured to display a trajectory determined by combining all input sources or a single source. FOV1 also displays the variable flight azimuths and the predicted impact area.

The Flight Termination System, also known as the Command Destruct system, is the means to carry out a decision to terminate a flight that violates the flight safety parameters. The system is a collection of ground based transmitters and antennas, a rocket borne receiver, and vehicle destruct package. The system is dynamic in that the different ground stations transmit their destruct functions based on the missile's position. The active configuration of the command subsystem is controlled by an operator assisted by the Range Safety Control and Display (RASCAD) system, which considers the site's health and status and the missile's actual position along with the predicted trajectory. The health and the status of the vehicles command destruct receiver is monitored prior to liftoff (LO) when the vehicle begins using its internal batteries. At that time, a command signal is sent to the vehicle to saturate the receiver, so that it cannot receive an

uncontrolled signal that might be taken as a destruct command. In addition to the jamming signal, check tones are sent to trigger a response of health and status information from the receiver.

The command system uses dedicated data links to connect Central Command, which is the control segment in the ROCC, to the launch head command sites and the XY building. Cape 1A and Cape 1B are the launch head sites that are connected with dedicated copper lines (Smith, 2008a). All other command sites are considered down range. These sites are Wallops Island, JDMTA, Argentina, and Antigua. Central Command uses dedicated secure copper lines to connect to the XY building where the circuit is switched to the down range data links.

The entire command system includes links besides the ones that transmit the command functions. These include voice communications and timing links as well as designated data for pointing antennas. For these purposes, the command sites are data consumers like other range sites. The dedicated links create a secure connection to the launch head command sites and to the XY building. The XY building is a communications network hub. From there a variety of links are available to the down range sites. The primary requirement is that there is no single point of failure, which is achieved by using two independent paths. This is usually a landline and a satellite connection, or in the case of JDMTA, a microwave radio link. The command functions are sent using the range's High Density Data format which is transmitted at a rate of 2.4 Kbps.

The command system may someday use the common range network. The reasons that led to using a dedicated network need to be considered in any plans to bring the command system on to the core network. The current requirement is to minimize risk (Smith, 2008a). If command were to use the common network, engineering would need to show that the risk remains very low. Different networking architectures and Quality of Service (QoS) provisions are available to ensure the delivery of command messages. In fact the right QoS settings would make the system better able to work if the network were under a denial of service type attack. The properly marked command messages would get through the malicious traffic.

4. Eastern Range Operational Configurations

The typical range configuration varies depending on the launch vehicle and the direction of flight. One succinct source is found in the ER Instrumentation Handbook (Computer Sciences Raytheon, 2008) as a chart titled “Typical Instrumentation Configurations for Eastern Range Launch Vehicles and Flight Azimuths.” This guide is useful in determining which instrumentation sites are assembled to form the range configuration for a given operation. It is interesting to note the dependence on Wallops Island for its telemetry, radar and command assets for North Easterly launches. Wallops Island is not part of the Eastern Range baseline. To use the Wallops Island assets means connecting them to the ER with commercially leased communications lines. When choosing a configuration to model, one should also consider the use of mobile command and telemetry at down range sites. This thesis will model the range configuration used for a North Easterly launch, which includes Wallops Island as a supporting range, and a mobile command and telemetry system at Argentina.

5. Communications Networking

a. Publish/Subscribe Systems

Publish/Subscribe (pub/sub) systems are a key technology for information dissemination. The basic functions of a pub/sub network are naturally publishing and subscribing. Publishing submits a piece of information, known as an event. The action of publishing an event is called a publishing operation. The event is generally structured as a set of attribute-value pairs, where the attribute has a name made up of a simple character string and a type. The type is one of the common primitive data types defined in programming or query languages. A subscription is the user expressing interest in data in terms of a set of constraints. These constraints are used to filter events. An event is said to match a subscription if it satisfies all the declared constraints. The verification of whether an event matches a subscription is called Matching. Subscription models are distinguished by the level of expressiveness they give to the subscriber’s interest. Highly expressive models lead to the possibility of a precise match.

Any module in a pub/sub communications system can take the role of Publisher or Subscriber. That is, the module can produce information (publish) or consume it (subscribe). System clients are not required to communicate directly with one another. The communications occur through systems nodes that coordinate themselves in order to route information from publisher to subscriber. Participant decoupling has advantages such as being able to ignore synchronization issues or direct addressing of subscribers. However, there are some disadvantages. It is very difficult to enforce any end-to-end QoS policy because of the non-deterministic behavior of the system. This non-determinism affects three fundamental aspects of QoS: security (specifically reliable message delivery), timely delivery, and trust relationship. A product discussed as being good is the Java Message Service (Corsaro, Querzoni, Scipioni, Tucci Piergiovanni, & Virgillito, 2006). It has the ability to handle a message-centric publish-subscribe model and it supports a point-to-point mode.

Reliable delivery is affected by the various network hops involved in transmissions over asynchronous Wide Area Network channels or temporary node overloading. The probability of receipt is increased with event persistence (stored in memory) and with retransmitted events.

Timeliness is a primary consideration. Real time applications often utilize a dedicated infrastructure for the strict controls they offer in order to meet timeliness requirements. Even in a completely managed environment the pub/sub system can have unpredictable processing delays at the nodes, or it can have routing anomalies. If timeliness needs to be closely controlled, the system should privilege point-to-point communications. This trades off the benefits of decoupling. Decoupling allows the infrastructure, rather than the publisher, to know all the subscribers. The benefit of that is the ability to scale the network to massive sizes with relative ease.

Security and Trust considerations deal with both the need to access data and assurances that the event is not corrupted in route.

b. Data Distribution Service for Real-time Systems

Many real-time applications require a pure data-centric exchange. Applications requiring selective information exchange are good candidates. Predictable distribution of data with little overhead is the primary goal. This can be controlled with Quality of Service parameters that affect predictability, overhead, and resource utilization. Distributed shared memory is a classic model, but it is difficult to implement efficiently over a network and it is not easily scalable (Object Management Group, 2007).

D. SUMMARY

Several stakeholders are involved in any discussion of the Spacelift Range architecture. The Eastern Range has a number of launch vehicles to accommodate, and they generally fly one of two basic trajectories (North East, or East). An interesting model is based on the most taxing load on the range network and will have as many different assets as practical, spread over a large geographic area. The point in time considered “the future” is the first major step in the range evolution that will be defined by the use of GPS metric tracking for all vehicles. GPS is currently used by some vehicles, and the range is equipped for this concept of operation. The lynchpin to operating the range system of systems is the data network. A viable networking option for the range is the Data-Centric Publish-Subscribe model, which is used in many real time applications.

THIS PAGE INTENTIONALLY LEFT BLANK

III. ANALYSIS AND RESULTS

A. INTRODUCTION

The analysis presentation is organized to follow the seven-step methodology developed by Osmundson and Huynh (2005).

B. ANALYSIS

1. Development of System of Systems Scenarios and Operational Architectures

The Eastern Range Capabilities Documentation (Computer Sciences Raytheon, 2008) includes a chart titled “Typical Instrumentation Configurations for Eastern Range Launch Vehicles and Flight Azimuths” that specifies typical range configurations for a collection of vehicles and trajectories. Instrumentation assets are generally ranked Range Mandatory (meaning they are a “must-have”), Range Required (meaning a launch could proceed without the asset), Available Spare (to achieve reliability through redundancy), or User Required/Mandatory. User Required/Mandatory assets are not necessary for range safety.

Command destruct sites at Cape Canaveral are generally considered launch mandatory. Command destruct sites at Jonathan Dickinson Missile Tracking Annex (JDMTA) are usually mandatory since there are times that the JDMTA sites have a better look angle.

Telemetry at TEL IV (TAA-3c and TAA 50-3), located at KSC, is required for the Space Shuttle and mandatory for Delta and Atlas launches. JDMTA is required for East bound launches. The launches from CCAFS or KSC generally require one of the four JDMTA telemetry assets. The other three are used for Navy Submarine Launched Ballistic Missiles. Space Shuttle launches add two more telemetry sites to the launch head area, one on Merritt Island and the other at Ponce De Leon.

Optics are generally required for all range launches. Many assets are mobile, so their location can be changed depending on the launch complex used.

Radar is currently required at CCAFS/KSC/PAFB. That usually includes several Missile Precision Instrumentation Radars (MIPIR, which uses a parabolic reflector antenna) and a phased array Multiple Object Tracking Radar (MOTR).

All command destruct sites are normally part of the range configuration. Some discussions of the AFTS era envision it in full use around 2018. That may be a reason to keep the command sites on a separate sub-net, as they are now. They generally have very strict reliability requirements, which may be another reason to put them on a separate network. On the other hand, they have a redundancy requirement, and a no single-point-of-failure (SPOF) requirement. A data network that offers multiple routing possibilities may be a good concept to meet that need. The ORD (Headquarters Air Force Space Command, DRSR, 2003) does not specify redundancy directly, but does say in Section 4.1.5.1 that “The ranges must be capable of uplinking commands (i.e. destruct, arm, safe, pilot tones/check channel 4 (WR), or control fuel burn) from launch through powered flight or separation of the last stage designed to accept commands.”

a. Conceptual Architectures

The system of systems concepts being evaluated are likely points in the range evolution toward the LET plan for an Eastern Range that will completely use GPS metric tracking by fiscal year 2011 (Shappell, 2008). A depiction of the LET plan is shown in Figure 4. The strike-throughs indicate assets that are deemed no longer required when GPS metric tracking is used for all vehicles. Divestiture of these assets will be phased, so the graphic makes a distinction between “New Shutdowns” (Radars 19.17 and 1.16 plus 3 mobile optical trackers), and Previous “Shutdowns.”

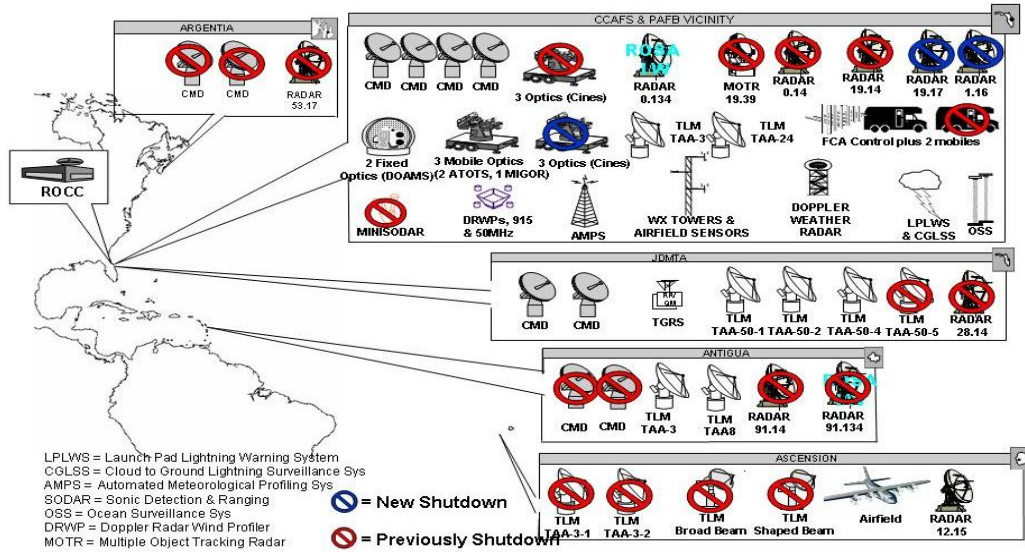

Figure 4. Conceptual View of Range Architecture (Slide 13, Shappell, 2008)

The Eastern Range Capabilities Documentation chart titled “Typical Instrumentation Configurations for Eastern Range Launch Vehicles and Flight Azimuths” shows North Easterly launches using radars at Wallops Island and Argentia (Computer Sciences Raytheon, 2008). Given the current trend, this thesis assumes telemetry will be used instead. The radar 0.134 and the launch head optics will not be included in the range safety metric track. For the flight profile considered, the range configuration (conceptual architecture) shown in Figure 5 would likely be used.

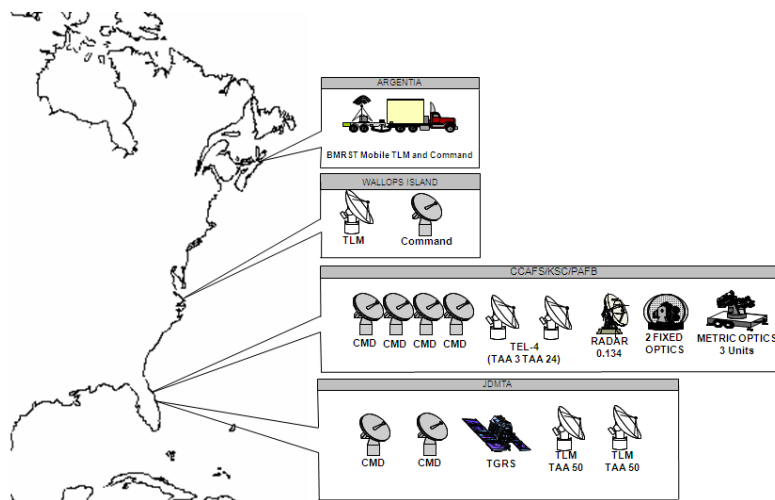

Figure 5. Conceptual Architecture

b. Operational Scenario

The operational scenario considered in this thesis is a North Easterly Launch. The expectation is that North Easterly launches will make use of command and telemetry at Wallops Island and will add mobile command and telemetry assets at Argentia. JDMTA typically supports North Easterly launches with two telemetry antennas and command. Currently the only ER GPS processing equipment, the Translated GPS Receiver System (TGRS) is located at JDMTA. The range allows customers to monitor data during the launch and access recorded data after the launch. There are currently no provisions for customers to attach their own instrumentation, such as telemetry antennas, or optics to the network as either an input source or a consumer of designates data.

Any operation will use voice and video to monitor status and for command and control. The Weather and Area Surveillance subsystems will also contribute to the network traffic. These loads are considered as a steady state level of background traffic. This thesis considers Area Surveillance to be a command and control function that primarily uses voice and video. Weather is currently connected to the range with a single OC-3 connection. For the purposes of this thesis, it is assumed that the required bandwidth is 75% of the available OC-3 capacity (Note: each OC-3 is capable of carrying 155 Mbps; 75% equals 116 Mbps). Similarly, it is assumed that video consumes 75% of the available bandwidth from the five OC-3 lines connecting “TVOC” to the core network (NOTE: five OC-3 lines are capable of 775 Mbps; 75% equals 581 Mbps). Voice is generally given 32 Kbps circuits, as seen in the CSR Technical Training Orientation (Gillis, 2008). Using the FRAT estimate of 600 voice users (FRAT, 2008, slide 111), each using 32Kbps circuits, requires 19.2 Mbps. This would be the case were it not for the ability to multiplex the voice circuits. One T-1 line, moving Extended Superframes at 1.544 Mbps, can handle 576 phone calls (Gillis, 2008). Going from 576 to 600 by linear scaling means 1.608 Mbps are used for voice.

In the modeling of the proposed modernized network, the voice and video are considered to be a constant steady-state level that shares the same communication infrastructure used by the sensors. The level of activity is that assumed by the FRAT. The FRAT network engineers (Gorlick, 2008), assuming the use of voice compression software, estimate each user will require 16 Kbps, which results in a 9.6 Mbps requirement for 600 users. For the video use of bandwidth, the assumption is that there will be 150 live feed cameras producing 1280 x 1024 pixel images (i.e., high definition TV quality) at a rate of 30 frames per second using real-time compression. The resulting load is less than 1 Gbps, (FRAT, 2007, slide 107), so the video load is assumed to be 999 Mbps. The FRAT does not explicitly consider the network loading imposed by the Weather and Area Surveillance subsystems. Again, weather is considered to use 75% of the bandwidth available from the single OC-3 connection and Area Surveillance is part of the voice and video load.

c. Range Network

In this thesis, the range is viewed as a sensor network with a hub and spokes out to the remote sensors. The hub includes the core data network, Centralized Telemetry Processing System (CTPS), FOV1 and the command destruct control system (Figure 6). The core data network receives a lot of attention in the FRAT plan (FRAT, 2007), since this part of the network needs to reliably meet strict timeliness requirements.

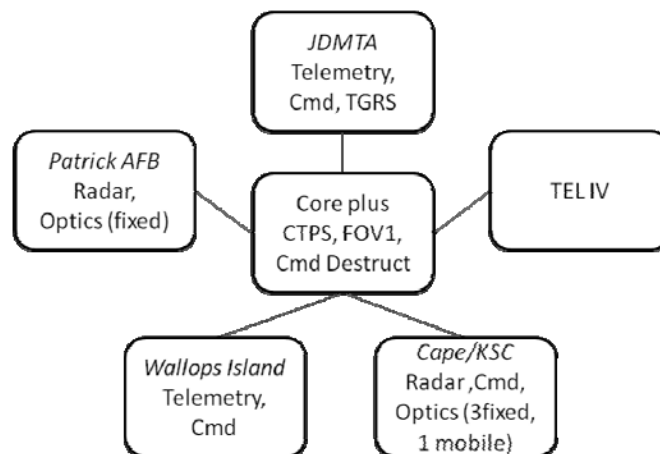

Figure 6. Hub and Spoke Sensor Network

d. Alternative 1: Legacy Network Model Architecture

A review of the Eastern Range Capabilities Documentation chart, “Typical Instrumentation Configurations for Eastern Range Launch Vehicles and Flight Azimuths,” shows that Wallops Island, JDMTA and the Launch Head assets will all be tracking at the same time. The times the missile is visible from JDMTA, the Launch Head, Wallops Island, and Argentina are shown in Table 4 (Computer Sciences Raytheon, 2008). The network model in this thesis considers data loads from Wallops Island, JDMTA and the Launch Head assets simultaneously. JDMTA and the Launch Head will have dropped off by the time Argentina can track the missile.

Table 4. Time Span (in seconds) of Missile Visibility from Various Sights

	JDMTA	Launch Head	Wallops Island	Argentina
Delta II	24-466	0-482	217-617	504-890
Atlas V	Not listed	0-483	217-617	549-793
Shuttle	49-450	0-425	196-683	Not listed

This model architecture uses the command destruct system and the sensors left by the LET plan after the range begins using GPS metric tracking for all launch vehicles. The metric tracking data, both GPS and IGS, will come through the telemetry systems. This configuration removes the radars and the optics from the range safety solution, so there will be no data flow from them, but they will receive designate data from FOV1. The communications infrastructure will be the equipment currently in use. Early in the launch, the assets contributing to the range safety solution are included among those seen in Figure 7. The model is based on these assets. The focus is the capability of the network to meet the bandwidth demands and meet the timeliness requirements.

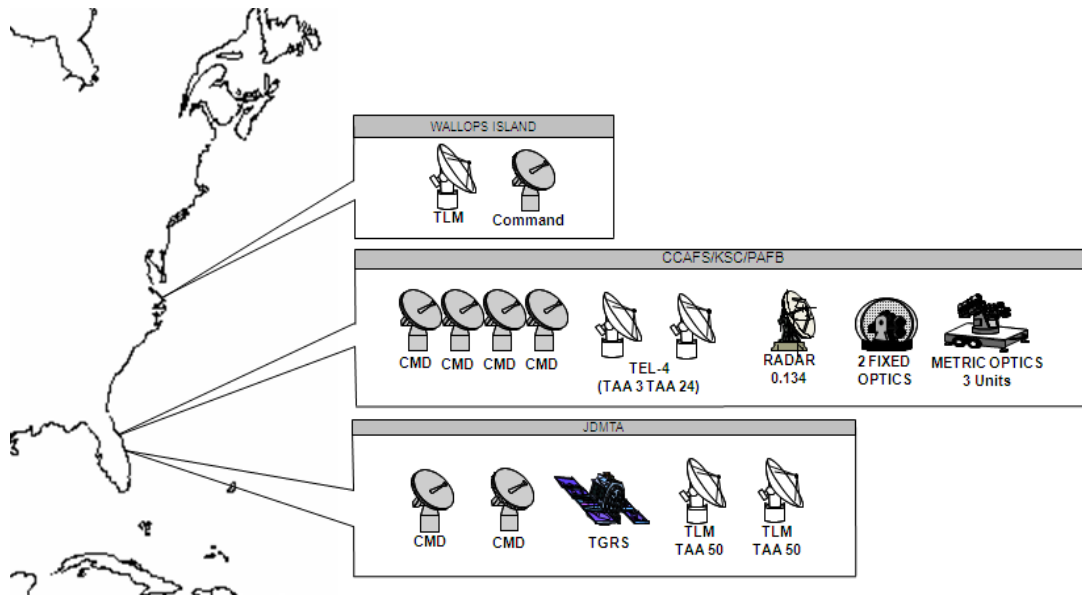

Figure 7. Model Architecture

e. Alternative 2: Modernized Network Model Architecture

This model architecture uses the same range systems as alternative 1, but the data network will use IP data packets rather than the current ATM cells.

2. Identification of System Threads

This thesis, following a thread from the OV-5 (Space Lift Range System Contractor, 2007a) focuses on the range’s ability to conduct launch operations. Thread 3, “Execute launch and test range operations,” has one top-level guard condition for reacting to a non-nominal flight when the missile violates flight safety parameters. It would involve a decision as to whether or not to destroy the rocket or otherwise interrupt powered flight.

The “Launch and Test Range Operations” thread is decomposed into:

- 3.1. Monitoring health and status of range instrumentation
- 3.2. Monitor space and launch vehicle preparation
- 3.3. Determine launch Go/No-Go status
- 3.4. Manage real-time flight operations
- 3.5. Track objects
- 3.6. Perform post launch activities

Thread 3.4, “Manage real-time flight operations,” covers the contingency for non-nominal flights that calls for sending a flight termination function.

As for the end of the thread, consideration is given to how OV-5 decomposes Item 3.4, “Manage real-time flight operations,” shown below. Items after 3.4.4.1 are shown in italics. The timeliness requirement will change considerably after all the debris tracking is complete. For that reason, Item 3.4.4.1 will be the end point of the thread.

3.4.1. Monitor best source metric data

3.4.1.1. Receive and send raw telemetry data

3.4.1.2. Receive and send radar metric data

3.4.1.3. Distribute time critical range safety telemetry information

3.4.1.4. Receive best source metric data

3.4.1.5. Monitor and select sources to ensure accurate display of metric and discrete indicators

3.4.1.6. Select and transmit best source metric data

3.4.1.7. Receive best source designate/acquisition data

3.4.2. Confirm Vehicle performance with respect to predicted vehicle performance

3.4.2.1. Detect missile liftoff

3.4.2.2. Receive missile liftoff indication

3.4.2.3. Report visual vehicle in-flight behavior

3.4.2.4. Evaluate vehicle in-flight telemetry measurements

3.4.2.5. Control mission flight control display

3.4.2.6. Monitor airborne range safety system health and status

3.4.2.7. Monitor vehicle performance with respect to predicted performance

3.4.3. Terminate non-nominal vehicle flight

3.4.3.1. Decide to terminate non-nominal flight with respect to violations of mission rule criteria

- 3.4.3.2. Declare vehicle flight non-nominal
- 3.4.3.3 Send flight termination function
- 3.4.3.4. Send back-up flight Termination Functions
- 3.4.3.5. Transmit termination functions
- 3.4.3.6. Verify vehicle destruction
- 3.4.4. Perform debris and toxin dispersion analysis based on catastrophic abort
 - 3.4.4.1. Determine debris impact area
 - 3.4.4.2. *Generate post-destruct data*
 - 3.4.4.3 *Receive and report post destruct data*
 - 3.4.4.4. *Determine refined instantaneous impact point data and debris impact area*
 - 3.4.4.5. *Determine updated toxin release times based on catastrophic abort*
 - 3.4.4.6. *Receive and report updated toxin release times*
 - 3.4.4.7. *Monitor updated toxin release times*
 - 3.4.4.8. *Release assets when clearance toxic times expire*
- 3.4.5. *Perform mission data lock down*
 - 3.4.5.1. *Ensure all launch related records and data is secured*
 - 3.4.5.2. *Direct data control and disposition actions*
 - 3.4.5.3. *Conduct data collection and disposition actions*
 - 3.4.5.4. *Gather, preserve and protect evidence*

3. Representation of Operational Architectures in a Unified Modeling Language (UML)-Like Format

This step corresponds to the OV-6c Diagram of the Department of Defense Architecture Framework (DoDAF). It provides an examination of the time-ordered exchange of information between the scenario actors. This view (Figure 9) helps define the interactions making up the operational thread and can help ensure each actor has the

necessary information when it is needed to perform the assigned operational activities. The range uses a hybrid view called an OV-6x. This analysis will draw excerpts from the OV-6x for non-nominal flights. The timing requirements in this view are driven by range safety considerations.

The Missile Flight Control Officer (MFCO) monitors the missile's flight to determine whether it is violating flight safety rules. The OV-6 will focus on the MFCO who is stationed in the ROCC. The MFCO is part of a team that includes the Range Control Officer, and Flight Safety Officer, as well as assistants to monitor the command destruct system and control displays. For this OV-6, this team will be considered a single entity referred to as the MFCO. The basic information flow is from the remote sites to FOV1, where it is processed and displayed in a form useful to the MFCO. FOV1 also sends target acquisition data (designate data) to the remote sites. The MFCO initiates the destruction sequence if deemed necessary.

The telemetry stream carries both GPS and Inertial Guidance System (IGS) metric tracking data. IGS data is transmitted to the ROCC where it is processed through CTPS. CTPS separates the data and outputs X, Y, Z, X', Y', Z', time, and site ID to FOV1. CTPS also processes the vehicle health and status information for display to the MFCO. GPS metric tracking data processing is done on the ground at the JDMTA telemetry site by a system called the Translated GPS Receiver System (TGRS). TGRS determines the missiles state vector and sends it to FOV1.

Optics and radar are still actors in the launch scenario even though their data will not be used to determine the missile state vector. Optics will supply visual data to the ROCC throughout the operation. Optics and radar will both track debris and they will both receive designate data from FOV1.

The event sequence (Figure 8) does not change as the missile flies down range, but the timeliness requirements do. For the launch area, the timing is 400 milliseconds for a sensor to get the data frame to FOV1, and then FOV1 has 100 milliseconds to process the data and produce a display. The MFCO needs to interpret the display, determine that a vehicle needs to be destroyed and then initiate the destruct sequence.

The time allotted to the MFCO is 1500 milliseconds. The command destruct system then has 55 milliseconds from the time the destruct sequence is initiated to the time the leading edge of the pulse carrying the command function leaves the antenna. For down range sites, the sensors have 1500 milliseconds to get a data frame to FOV1, and the command system has 55 milliseconds plus the data link latency which varies depending on the specific site (Smith, 2008b) to start sending the destruct signal.

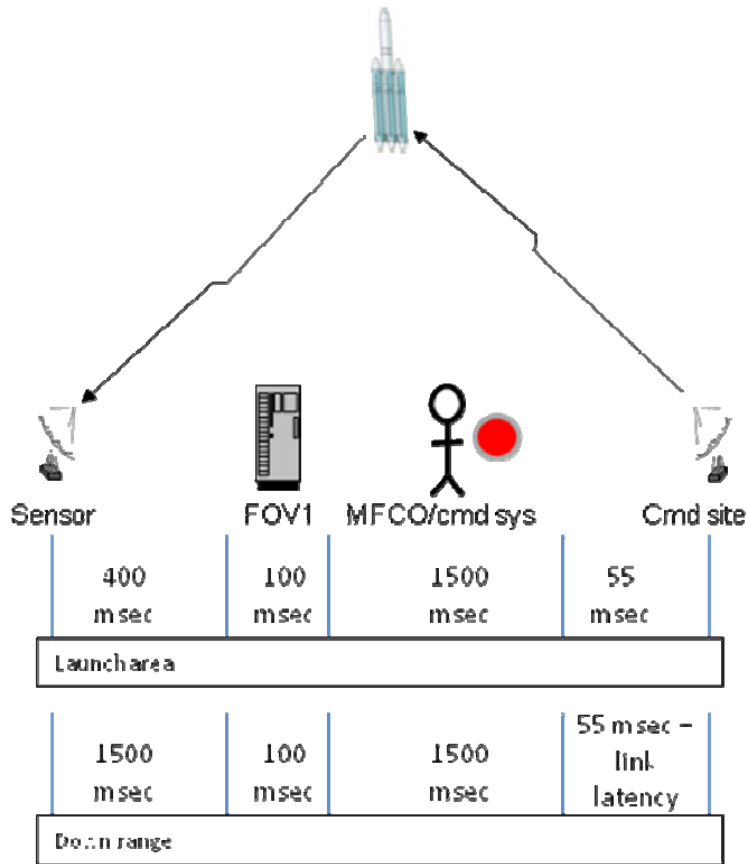

Figure 8. Non-nominal Launch Event Timing

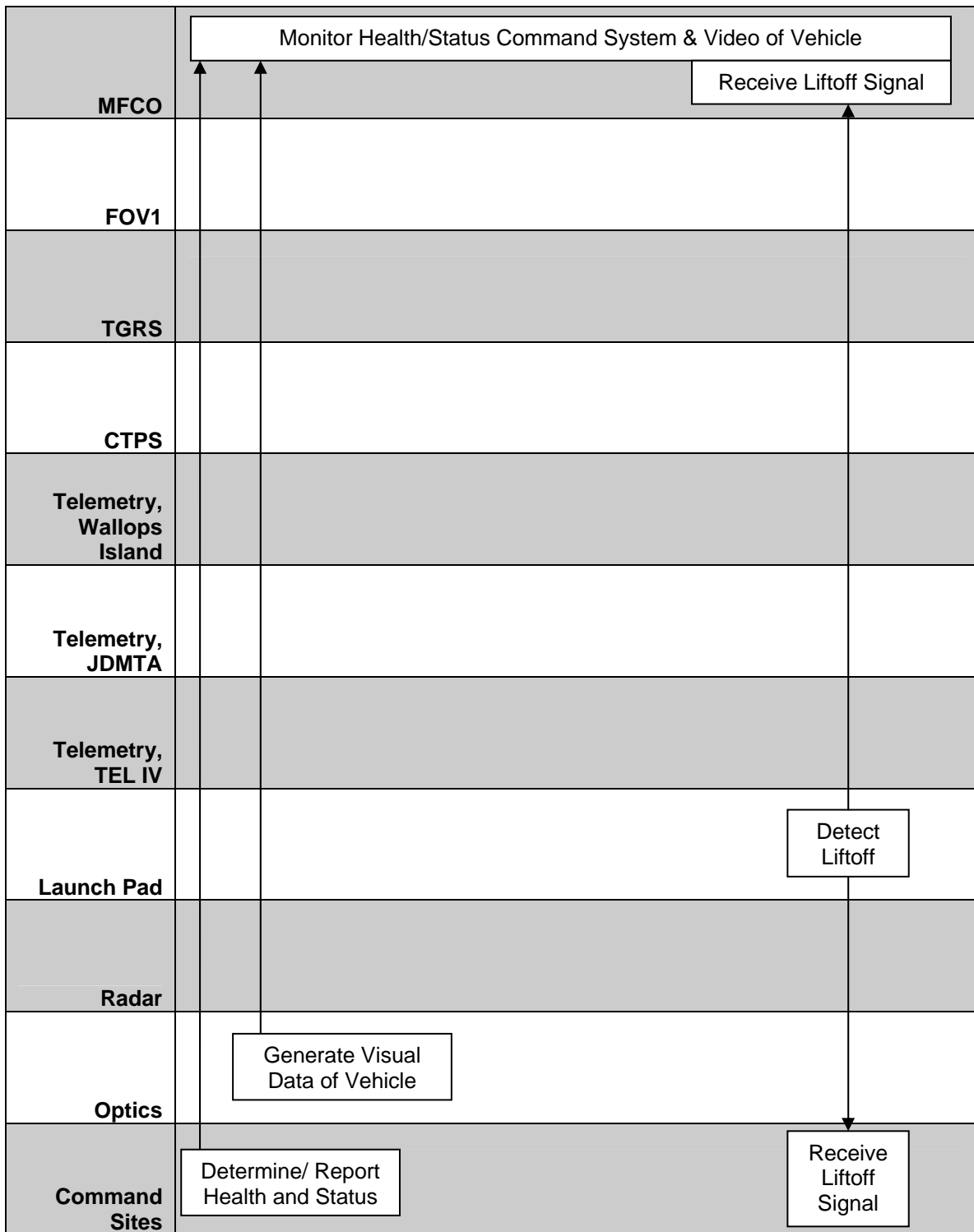
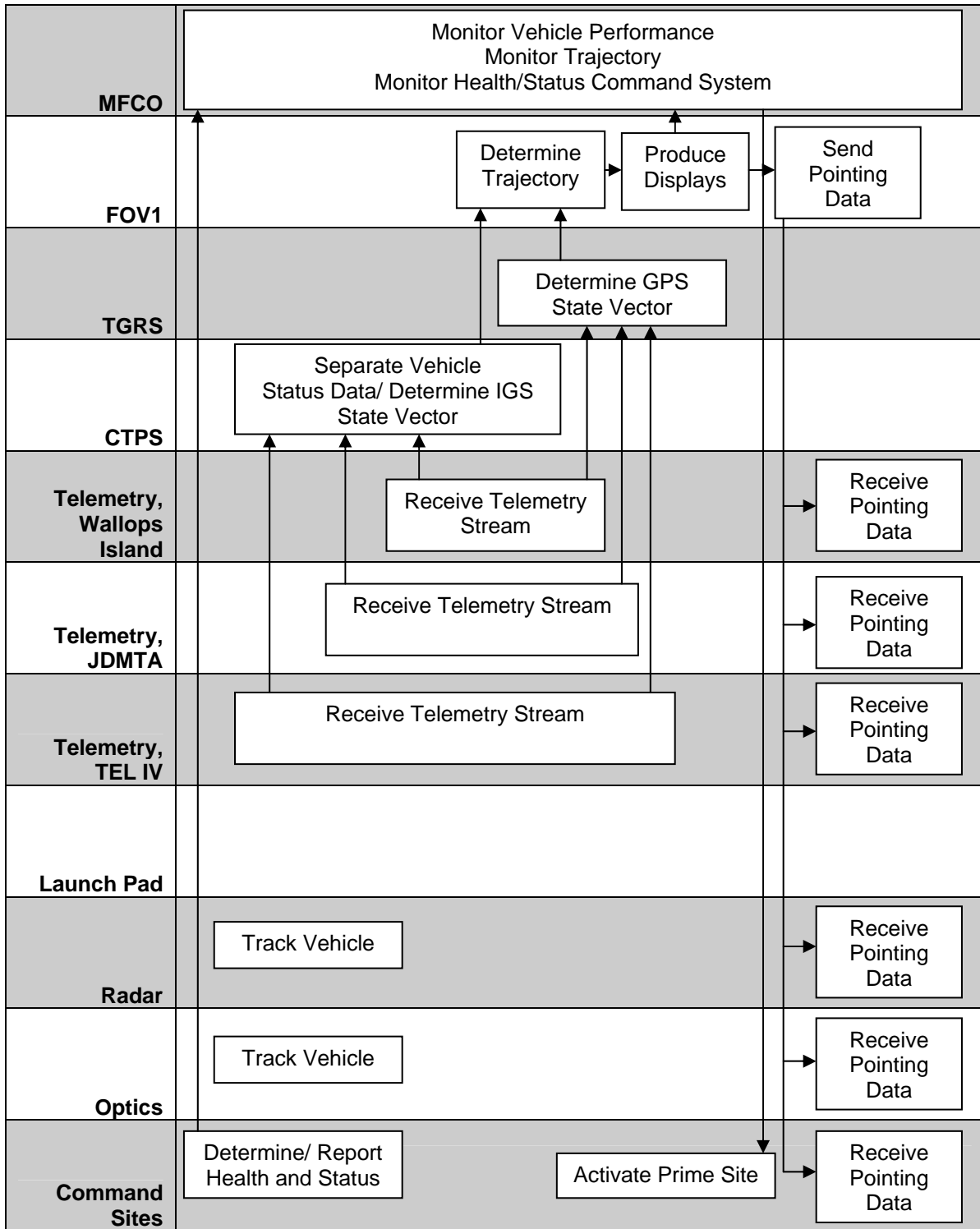
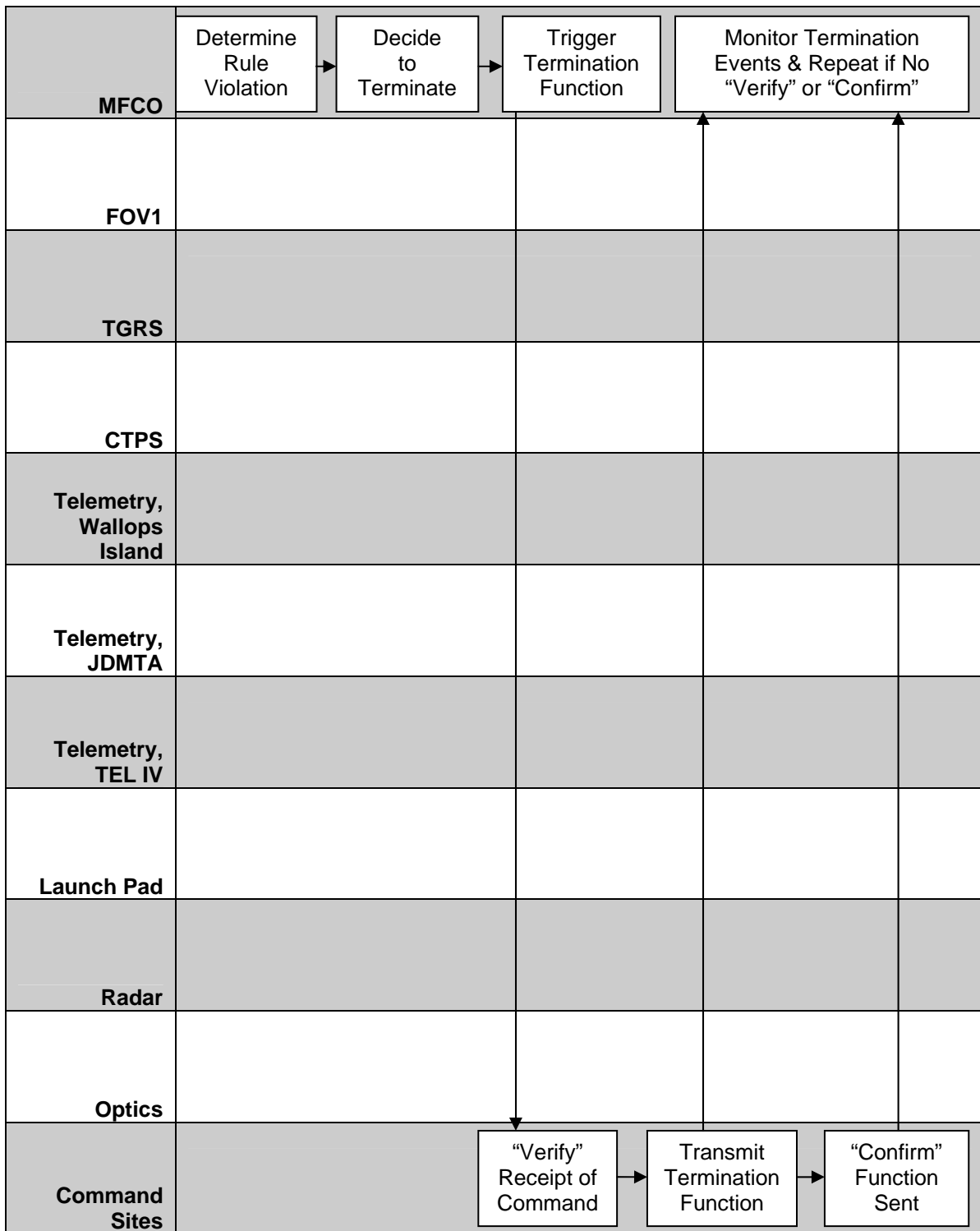

Figure 9. Representation of Operational Scenario



Representation of Operational Scenario (continued)



Representation of Operational Scenario (continued)

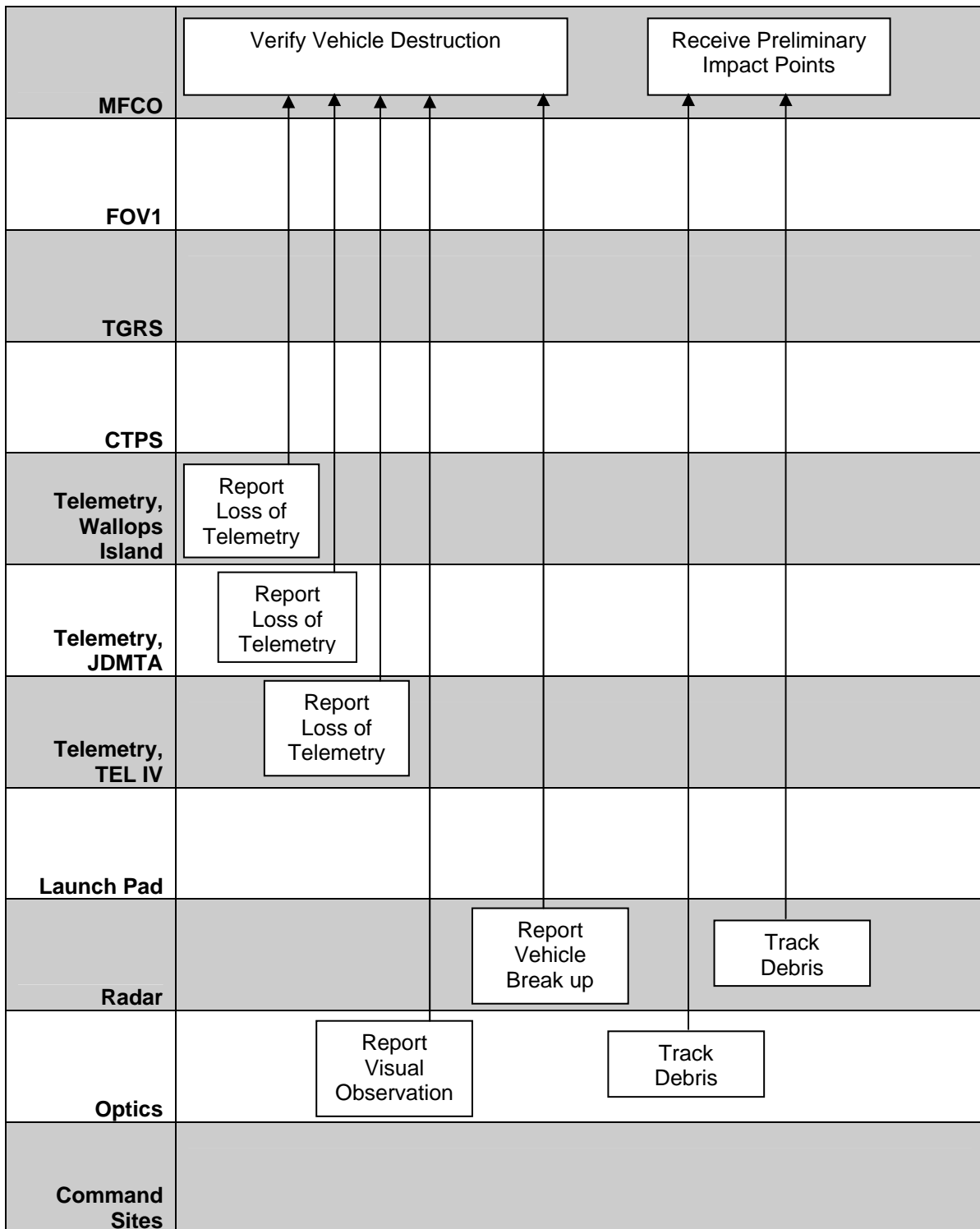

Representation of Operational Scenario (continued)

4. Identification of System of Systems Design Parameters and Factor Levels

Network system performance is driven by the way the various range systems are joined to create the system of systems. A popular approach is the use of Publish/Subscribe Middleware. Quality of Service measures that lend themselves to becoming design parameters for this analysis are 1) timeliness 2) reliability and 3) availability (Corsaro, Querzoni, Scipioni, Tucci Piergiovanni, & Virgillito, 2006). For this application, availability addresses sizing the network to ensure data can flow to the required location by the time it is needed. The availability parameter is evaluated using a throughput analysis and does not consider availability in the sense of equipment failure.

a. Timeliness

The principal driver for sensor data timeliness is the FOVI synchronization scheme that groups 400-millisecond old data frames. This is one element in an overall range timeliness requirement. The overall range timeliness requirement is driven by the need to protect the public from the hazards potentially resulting from a missile that violates flight safety rules.

b. Reliability

In the legacy network configuration, reliability is addressed by requiring two independent paths for range safety critical data for reliably through redundancy. For the parts of the range network that consist of leased commercial lines, the reliability guaranties need to be considered because how the reliability is achieved is beyond the range's control. Decisions to migrate to a new range network configuration will need to consider network reliability and examine the fault tolerance and robustness of the network. Simply mandating two paths may not be the best solution. Other network topologies with the ability to route traffic to meet the QoS requirements might prove to be the best solution. Corsaro et al (2006) suggest that factors affecting reliability include persistence of events and event retransmission. In considering a move toward an IP-based network, one might consider if there is time or a need to resend lost packets. This

may not be necessary since data packets are set every 100 milliseconds. Additionally, FOV1 is tolerant of an occasional missed data frame. This, combined with data latency limitation, makes retransmission unnecessary.

Corsaro et al (2006) also discuss a “lifespan” parameter that allows control over the time interval for which the data will be valid. The lifespan of the data is set by FOV1. Radar and optics data frames up to one second old will be processed whereas telemetry borne data (IGS and GPS) up to 1.2 seconds is allowable, although a 400-millisecond time span for all data is desirable. The current FOV1 configuration is set up to synchronize inputs so that all 400 millisecond old data frames are processed at the same time. If the data is not used in that time, it should not remain in the network. Additionally, there is no reason to check receipt of a data frame and communicate it back to the provider, because messages are created and sent rapidly (10 per second). If an expected data frame fails to arrive on time, FOV1 will compute the solution using available data.

c. Availability

Ensuring data arrives where it is needed in the allotted time is dependent on having enough bandwidth. There are two basic types of data used during launch operations: range safety data and customer data. The range safety data is necessary to determine a state vector for the missile and for monitoring health and status of the command receiver. The customer data can be subdivided into two groups: the data that need be processed in real time and the data that can be recorded and processed after the mission. Basic vehicle health and status data is sent real time. There is a dividing line between the data that can wait based on customer wants. In some cases, the entire telemetry stream needs to be sent to the ROCC, since the safety data may not be put on a dedicated channel.

Ideally, one would not have to wait for data, but certain data, such as engineering analysis optics data, would require huge amounts of bandwidth. Since analysis can be done after the launch, the data can be stored and transmitted later. Radar imaging or tracks made with very high sample rates could potentially create large

amounts of data that could be used for later analysis of debris metrics and discrimination. Clearly some data needs extensive analysis that cannot be done in the time span of a launch operation, so transporting it can happen after the operation.

With a view of the range as a sensor network, the throughput requirements for the legacy sensors are very small. Radar and optics are designed for a 2.4-Kbps data stream, and Telemetry is set up for a 4.8-Kbps data stream. These rates are actually a bigger problem for timeliness than for throughput, because it takes a significant amount of time to build a data frame. A 240-bit frame built at 2.4-Kbps and 4.8-Kbps rates takes, respectively 100 and 50 milliseconds to complete. Additionally, there is a 60 millisecond delay when transporting these sub-rate data frames onto the range network (Gillis, 2008).

The telemetry capacity requirement needs to be evaluated as new Spacelift vehicles are developed. The Telemetry Subsystem Specification is calling for 10 Mbps. Early indications are that the NASA Aries program will have telemetry streams as large as 30 Mbps. One approach to handling this load is for the telemetry stream to have a spare channel to allow a small portion of the stream to be separated for use for range safety data, and the rest recorded. Another approach may be to have an IP-based telemetry signal that the site processes at the routing level (Gorlick, 2008).

5. Transformation of UML-like Format Representation into Executable Models

The design parameters consist of availability (throughput) and timeliness.

a. Availability

The availability model analyzes required data flow by focusing on the nodes connecting remote site data links to the core data network. The model sums the volume of data that flows in and out of the core network through various nodes and compares the result to the rated capacity of 622 Mbps. Similarly, the individual throughputs are summed and compared to the node throughput capacity of 2088 Mbps.

The core has eight switches on the outer ring and seven on the inner ring. This analysis models the core as six switches with four on the outer ring and two on the inner ring (Figure 10). The primary focus is on the range safety information and the need to process it at the ROCC and present it for consideration to the MFCO. In addition to the flow of range safety data to FOV1, and the target acquisition data going back to the remote sites, the analysis assumes steady state network traffic that includes video, voice, and weather.

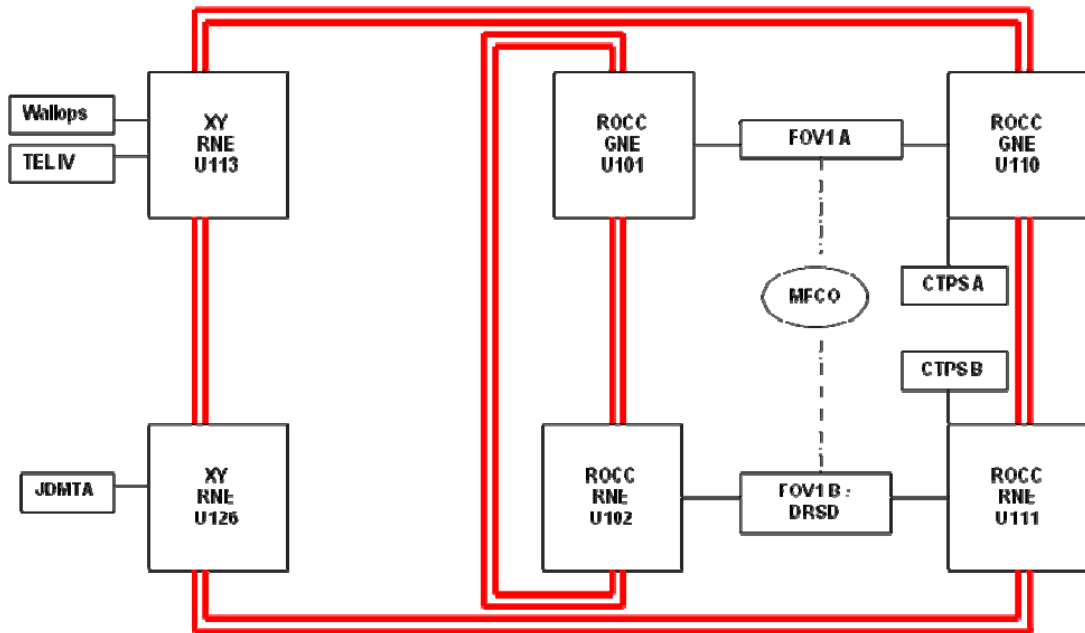

Figure 10. Model Representation of Range Network

With a focus on getting sensor information to FOV1/DRSD, the paths being modeled are 1) Telemetry data to get on the core for transport to CTPS, then to FOV1, and 2) Telemetry data to get on the core for transport to TGRS, then to FOV1 (Figure 11).

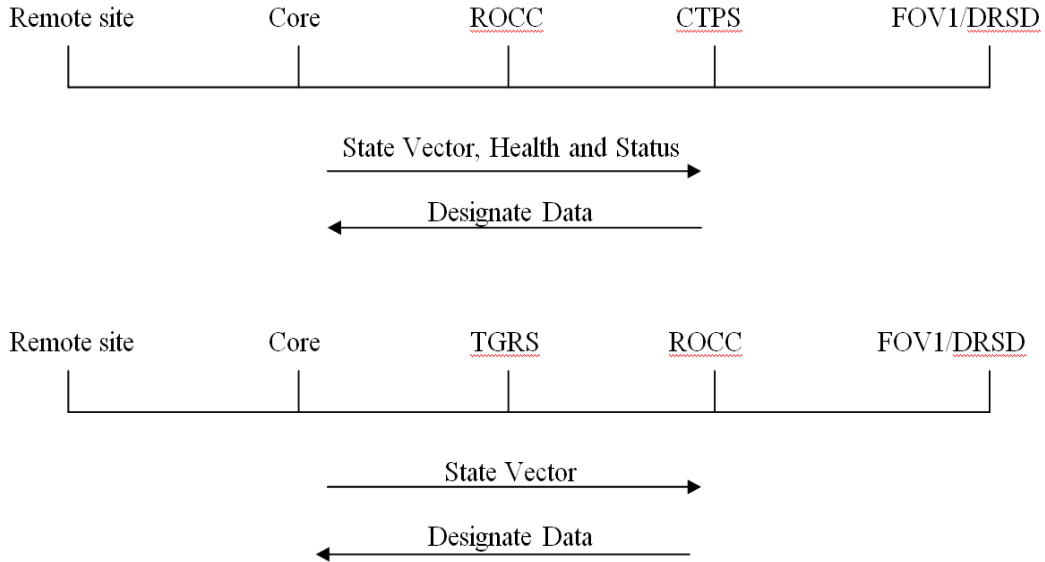

Figure 11. Basic Data Flow Model

During a launch operation, the circuits, or data paths, are predetermined. The only variation comes from routing on the core. The core rings are designed to be fault tolerant in that they react to a node failure by routing the network traffic around the ring in the opposite direction. The only capability lost is the ability to add or remove data from the core via the failed node. The input and output nodes for the circuits stay static. The reliability issue is addressed by setting up redundant paths that carry the same data. The basic node-by-node analysis of throughput is done for the current network and for the FRAT proposed network that is based on IP packets. The current network uses ATM cells. The type of data flowing on the network will be the same, but the volume will differ slightly. The node model used is shown as Figure 12.

Core Node for subsystem

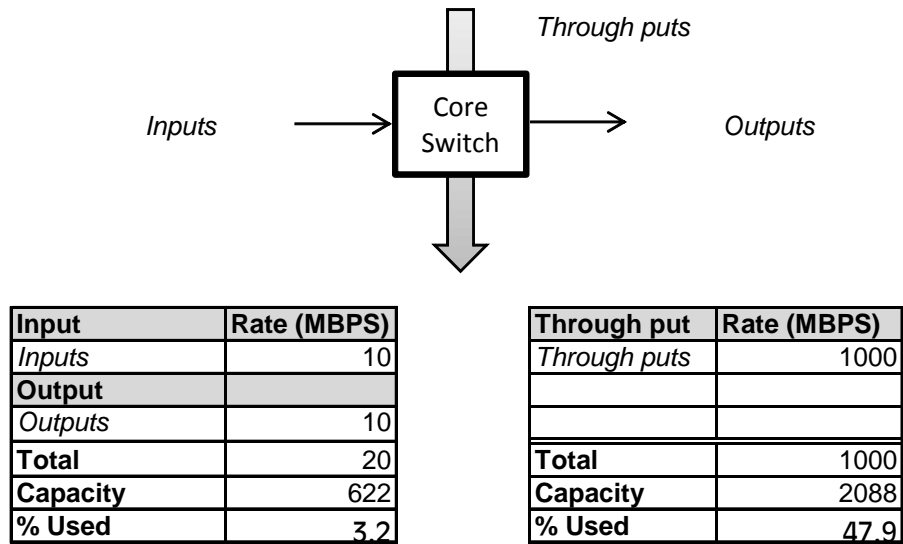

Figure 12. Basic Flow Model

The sum of the inputs and outputs is compared to the capacity of the data link connecting to the node to determine if the link has the required bandwidth.

b. Timeliness

The timeliness model analyzes the latency of the data flow from remote sensors to FOV1. The focus is on the network— both the legacy and FRAT proposed network. The analysis is done by summing the data latency caused by the various processes performed to create the data links. The data link latency is added to the TGRS or CTPS processing time and compared to the 400 millisecond allocated for getting data to FOV1. The CTPS processing time is assumed to be the difference in the time budgets for telemetry and radar, which is an extra 200 milliseconds. The TGRS processing time is assumed to be the same as CTPSs.

The difference in data latencies is most pronounced at the edge devices that transition data on or off the core network. The data latency in the legacy network caused by the edge devices is tabulated in Table 5 (Morton, 2008).

Table 5.

Table 6. Edge Device Delay Times from Interfacing with Various Circuit Types

OC-48 transitioned to/from	Delay (milliseconds)
Low speed synchronous serial (2.4 Kbps)	60
Individual DS0 (56 Kbps) channel in DS-1	37
DS-1 circuit	3

An IP packet-based network will also introduce a data latency at the edge devices. The latency is estimated to be 5-10 milliseconds (Bryant, 2008). Since the legacy network meets the latency requirements and since the proposed IP network is faster, the IP network will meet the need.

Review of the data link latency of a range configured to use GPS metric tracking for range safety now follows. The timeliness analysis focuses on the circuit path that is the worst case in terms of time budgets. The tightest time requirement is for the launch head sensors. They have to have data to FOV1 in no more than 400 milliseconds. TEL IV (telemetry) will be the only launch head sensors left after the range begins using GPS metric tracking for all launches. The analysis focuses on the data links that take TEL IV (launch head) data to JDMTA (down range) to be processed through TGRS and then carries the TGRS computed state vector to FOV1.

TEL IV data is routed through the XY building as it is transmitted to JDMTA. The time needed to get data from TEL IV to the XY building is 5 milliseconds. This value is based on a measured time of 10 milliseconds for telemetry data to pass from the TEL IV WANIU through the CTPS WANIU (Space Lift Range System Contractor, 2004). Because the latency for traveling along the fiber optic data link is negligible, this analysis assumes a 10-millisecond latency is attributable to processing by two WANIUs, each taking 5 milliseconds. This assumption is used for both the microwave path and the landline path. Data also has both a microwave path and a landline path from the XY building to JDMTA.

The landline trip from the XY building to JDMTA begins at switch XY_RNE_U15 and travels via commercially leased lines consisting of a 56-KB multiplexed data lines, four T-1 lines, and two 64-KB control lines (Computer Sciences Raytheon, 2008). The data latency of the leased lines is estimated because the exact routing is not known. To estimate the data latency, this analysis assumes the data is aggregated on to an OC-48 line for a section of the trip, but the section is too short to realize any advantage over using the T-1 lines. The result is added latency for the conversion process. Additionally, the analysis assumes that the path length is twice the shortest route distance. The trip from switch XY_RNE_U126 to JDMTA and back will be modeled as shown in Figure 13.

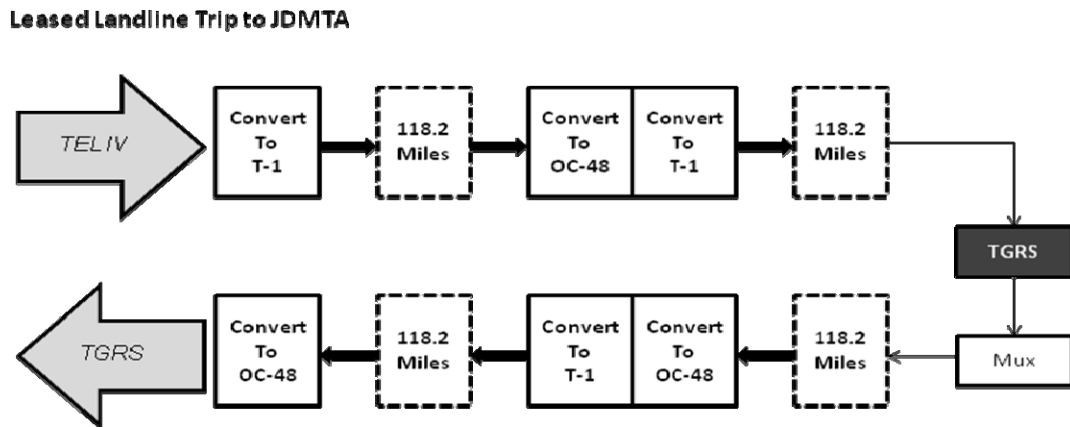

Figure 13. Landline Path Model

Analyzing the microwave path begins with the assumption that the data that travels from TEL IV via microwave to the XY building will stay on the microwave path and will be relayed to JDMTA. The alternative is to put the TEL IV data onto the core through the OC-48 fiber from switches XY_RNE_U113 to XY_RNE_U126. Doing so would involve processing the data through the SONET multiplexer to put the data on the core, and back through another SONET multiplexer to get back on the microwave link.

The microwave path from TEL IV to JDMTA goes through 5 repeater stations and travel 118.2 miles. When the data gets to JDMTA it goes through a WANIU before it is processed by TGRS. On the return trip, the TGRS output data is multiplexed

and aggregated into a 53-Byte data frame that can be put onto the network, which will take approximately 25 milliseconds. Figure 14 illustrates this path. The processing time used in this analysis for multiplexing and de-multiplexing is derived from latency measurements for telemetry data coming from the remote sites. The measurements were reported in a characterization of the Post-Detect Telemetry Subsystem WANIU (Space Lift Range System Contractor, 2004). The measurement is taken from the time data entered the WANIU at the remote site until it is processed through the WANIU that feeds into CTPS. To determine the time attributable to multiplexing and de-multiplexing, the portion of that time attributable to data traveling the physical distance from remote site to the ROCC is subtracted from the measured time. The resulting time is divided by two since there is a WANIU at both ends. After the return trip via the microwave system, the data goes through another Alcatel radio and is multiplexed in order to input into switch XY_RNE_126.

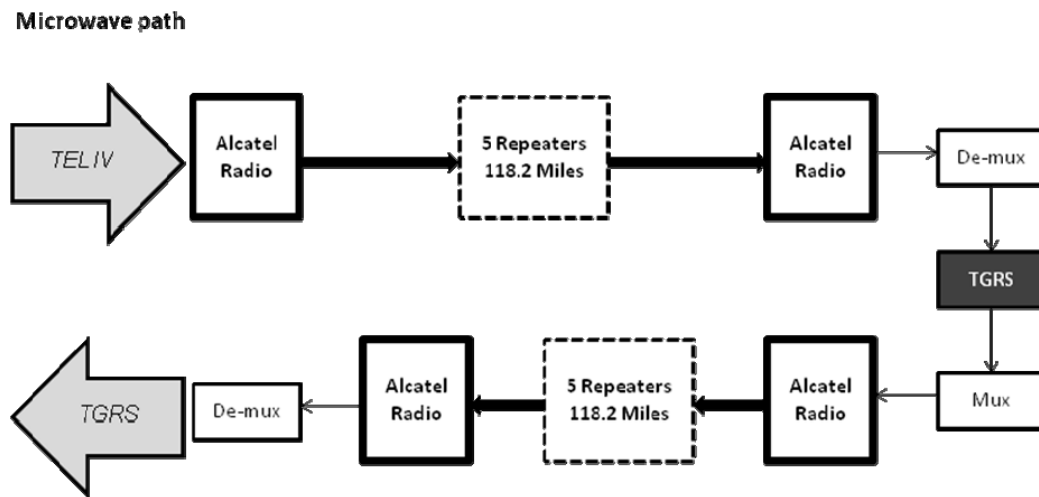

Figure 14. Microwave Path Model

The delay from converting the data to an analog radio transmission is assumed to be the same as the repeater time delay since both operations are processed through an Alcatel 4308S radio. Some insight into the time delay comes from a study (Allen, 1994) that characterizes the delay in the repeaters used in an Alcatel Network Systems microwave network. The study reports the worst-case delay of 577 microseconds.

The time required for TGRS data to reach the core is the same as the time necessary to reach FOV1 because the core is so fast that the latency from the XY building to FOV1 is negligible (Morton, 2008). Therefore, the total latency for getting a GPS state vector from telemetry data collected at TEL IV data is the sum of the time needed to get telemetry data from TEL IV to the XY building, the time to get the data to JDMTA and back, and the TGRS processing time.

c. Timelines: Backward Compatibility

The effect of making modern sensors adhere to the legacy communications standards is evaluated by considering the range radar re-capitalization projects. Legacy radar produces data in 240-bit frames. The re-capitalized radars using MIT-LL ROSA are required to produce such data, however the 240-bit data frame is not amenable to transport on the data network, which transfers T-1 size data frames. The process time for converting 240-bit data frames to T-1 frames is 60 milliseconds (Computer Sciences Raytheon, 2008). In addition to the 60-millisecond conversion latency, there is an additional 100 milliseconds needed to receive the 240 bit data frame at the 2.4-Kbps rate resulting in 160 milliseconds for the conversion process. This latency and the system complexity that come with this conversion could have been avoided because the ROSA data is readily available in the T-1 format. The requirement for the new radars to output a legacy format should be changed so the output is compatible with the data network.

6. Application of Design of Experiments

This thesis compares two architectures rather than comparing a variety of solutions that were generated by varying several parameters. This course of action was shaped by a Headquarters Air Force Space Command (AFSPC) decision regarding the evolution of the range. This thesis is concerned with evaluating the range readiness to achieve the AFSPC commander's vision and considers the feasibility of adopting the FRAT. The problem is bounded by considering only the minimum and maximum data load on the range network. The minimum load is associated with the currently network

and the maximum load would correspond to the FRAT plan network. Design of experiments is not used since only two configurations are considered.

7. Modeling and Analysis of Results

Two models are used, one to assess availability and the other to evaluate timeliness. The availability model analyzes required data flow by summing the volume of data that flows in and out of the core network through various nodes and compares the result to the rated capacity of 622 Mbps. Similarly, the individual throughputs are summed and compared to the node throughput capacity of 2088 Mbps. The timeliness model analyzes the latency of the data flow from remote sensors to FOV1. The focus is on the network— both the legacy and FRAT proposed network. The analysis is done by summing the data latency caused by the various processes performed to create the data links.

A large set of the data that flows through the network is modeled as steady-state network traffic, consisting of video, voice, and weather data. Additional throughput includes 20 Mbps of telemetry data (10 Mbps on both the primary and secondary paths) from each of three sites, two sets of TGRS data, and two sets of designated data returning to the remote sites. The node throughput analysis is summarized in Table 6.

Table 7. Network Traffic that Passes Through the Network Nodes

	Legacy Network (Mbps)	FRAT IP Based Network (Mbps)
Video	581	999
Voice	1.608	9.6
Weather	116	116
Telemetry	60	60
TGRS	0.074	0.082
Target Acquisition Data	0.008	0.010
SUM	758.7	1184.6
Capacity	2088	2088
% Used	36	57

One major difference between the legacy network and the FRAT proposed network is that the FRAT plan calls for using high definition quality video and voice over IP. Another difference is that the legacy network uses 53-Byte cells compared to the 64-Byte IP packets. This difference will have a small impact on the bandwidth consumed by the legacy data. In order to reduce latency, low rate data frames are put in cells (or packets) that are sent before they are full, because it takes too long to fill the cells with the low rate input. In the current range network, 424-bit cells are sent with the legacy 240-bit frame and 184 filler bits, which use 1.77 times more bandwidth than cells completely filled with data. Similarly, a 64-Byte packet consumes 2.13 times more bandwidth. This bandwidth penalty is applied to the legacy data coming from TGRS and CTPS, as well as the Health/Status data and the designated data. A comparison of the bandwidth consumed under different data structuring options is summarized in Table 7.

Table 8. Comparison of Bandwidth Consumed Under Different Data Structures

	Raw Data (Mbps)	Data in Cells (Mbps)	Data in IP Packets (Mbps)
TGRS	0.019	0.034	0.041
CTPS	0.014	0.025	0.029
Health/Status	0.064	0.113	0.136

Note that the terms input and output are from the point of view of the core. When a process needs data, it is an output from the core. The results from running the process are inputs to the core. For example, processing TRGS at JDMTA requires that the TEL IV and Wallops telemetry streams be taken as output from the network core. JDMTA will process data with TGRS and input the data on to the core. JDMTA will also input its own telemetry stream so it can be processed at TEL IV and by CTPS.

a. Availability

The nodes that bring Telemetry data to CTPS are the ATM switches designated as ROCC_GNE_U110, which handles CTPS A, and ROCC_RNE_U111, which handles CTPS B. The throughput model for ROCC_GNE_U110 is shown in Figure 15 below. The results for all the nodes are summarized in Table 8.

Core Node for CTPS

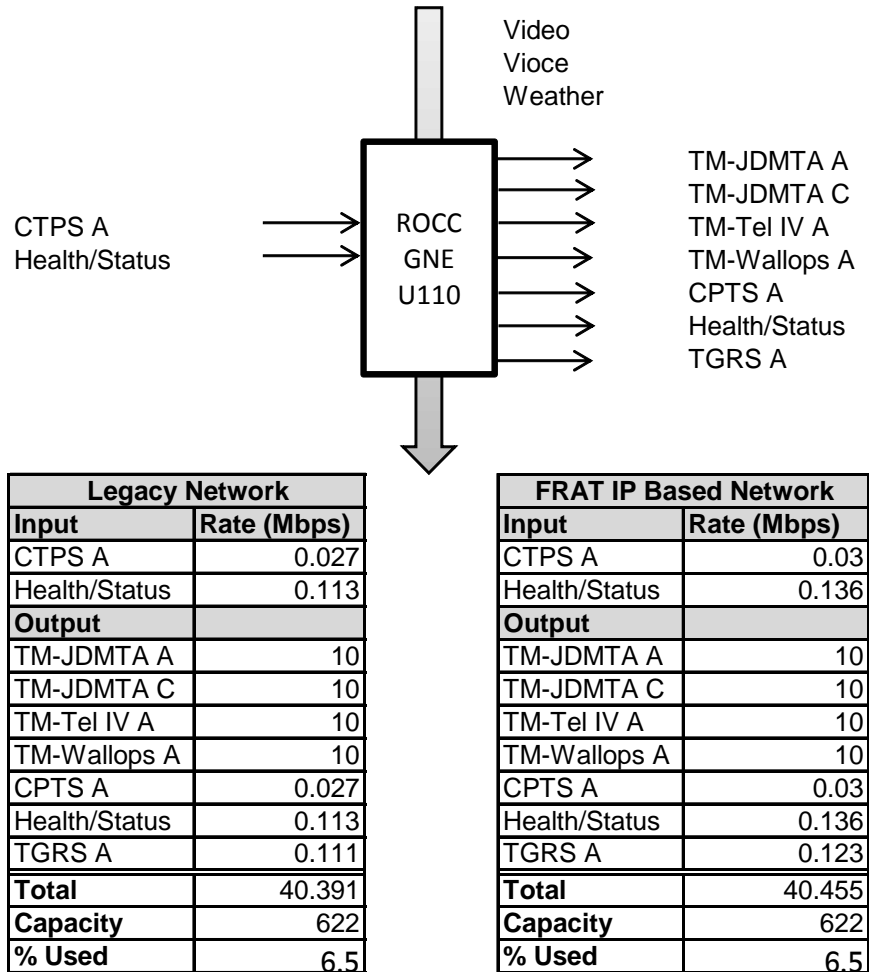

Figure 15. Core Node Connected to CTPS

Another important set of nodes for range safety are the nodes that send Telemetry data to JDMTA where it is processed through TGRS. JDMTA is connected to the XY building by commercial communication links and by an Alcatel microwave radio system. The microwave link has the capacity of an OC-3 line and the commercial link uses four T-1 lines (Space Lift Range System Contractor, 2007). All JDMTA data comes through a single Cellworx® switch designated as XY_RNE_U126. The range generally uses redundant data links but this switch is a single point of failure because both links use the switch. If this single point of failure is a problem, a potential solution is to switch microwave receiver connections between JDMTA and TEL IV, which is connected to switch XY_RNE_U113, also in the XY building.

The connection between the core and JDMTA needs further consideration. The commercial link, using four T-1 lines, is only capable of carrying 6.176 Mbps. If entire telemetry streams do need to be sent for TGRS processing, the requirement would be 40 Mbps. Either the volume of telemetry data needs to be reduced or the link capacity increased.

After the data is processed through CPTS and TGRS, it needs to be processed by FOV1 and DRSD and displayed for the MFCO. FOV1 B and DRSD can receive inputs through switches ROCC_RNE_U102 and ROCC_RNE_U111. FOV1 A receives its data from ROCC_GNE_U101 and ROCC_RNE_U110.

Table 9. Network Traffic Put On or Removed from the Core Through Various Nodes
(Note that the capacity to add and remove data is 622 Mbps)

	Legacy		FRAT IP Based	
	Total	% Used	Total	% Used
ROCC_GNE_U110	40.32	6.5	40.38	6.5
ROCC_RNE_U111	40.32	6.5	40.38	6.5
XY_RNE_126	80.07	12.9	80.07	12.9
XY_RNE_113	40.07	6.4	40.09	6.4
ROCC_GNE_U101	0.238	0	0.262	0
ROCC_RNE_U102	0.238	0	0.262	0

b. Timeliness

The commercial landline model sums the time required for each leg of the path from the XY building until the TGRS data is put on the core through switch XY_RNE_U126. The results are shown in Figure 16.

Leased Landline Trip to JDMTA

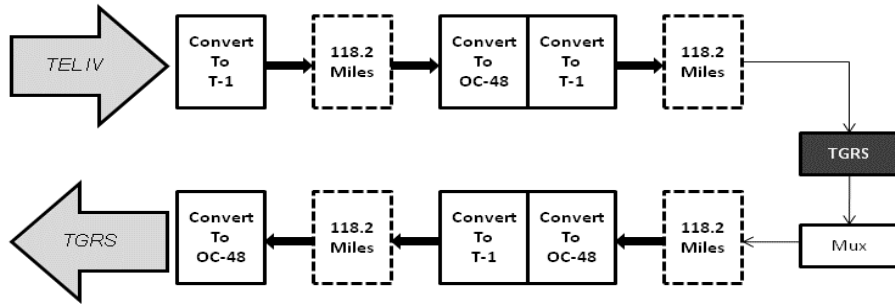

Element	Delay (msec)
Convert to T-1	3
Travel 118.2 miles	0.63
Convert to OC-48	3
Convert to T-1	3
Travel 118.2 miles	0.63
Multiplex	24.7
Travel 118.2 miles	0.63
Convert to OC-48	3
Convert to T-1	3
Travel 118.2 miles	0.63
Convert to OC-48	3
Total	45.22

Figure 16. Data Timeliness Model Using Commercial Landlines from JDMTA to the Core Network

The total data latency is determined by adding the latency for data travel from TEL IV to the core, the TGRS processing time, and the time needed to get data to JDMTA and back. The result is an overall time of 250 milliseconds, which is within the 400-millisecond time budget.

The microwave link model sums the time required for each leg of the path from the XY building until the TGRS data is put on the core through switch XY_RNE_U126. The results are shown in Figure 17.

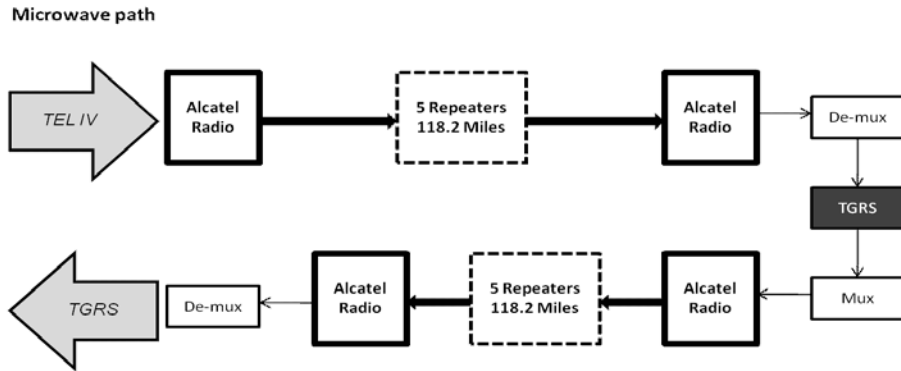

Element	Delay (msec)
Alcatel Radio	0.58
5 Repeaters	2.89
Travel 118.2 miles	0.63
Alcatel Radio	0.58
De-multiplex	24.7
Multiplex (plus framing)	24.7
Alcatel Radio	0.58
5 Repeaters	2.89
Travel 118.2 miles	0.63
Alcatel Radio	0.58
De-multiplex (to DS-1)	3
Total	61.74

Figure 17. Data Timeliness Model Using the Microwave Radio System from JDMTA to the Core Network

The total data latency is determined to be 267 milliseconds, which accounts for traveling from TEL IV to the core network, the TGRS processing time, and the time needed for data to travel to JDMTA and back. This latency is within the 400-millisecond time budget.

C. RESULTS

Regarding the availability requirements, the total load on the data network is estimated to be 36% of the capacity using the legacy systems and 57% if various modernized systems (e.g. voice over IP, IP based video) are used. Range safety data is less than 8% of the total load. As for the ability to add and remove data from the core, range safety uses at most 13% of the available capacity, which is driven by large volumes of telemetry data.

The commercial leased lines to JDMTA are a potential area for a data bottleneck. The data link, using four T-1 lines, is capable of carrying 6.176 Mbps. The capacity required to send all the telemetry data is 40 Mbps. The problem of the bandwidth demand exceeding the available capacity can be addressed by either increasing capacity, or decreasing demand. The demand can be decreased if the portion of the telemetry stream carrying the GPS data can be separated so that only a subset of the data is sent to JDMTA. If the GPS data were carried on a separate telemetry channel, the required capacity would likely be close to 40 Kbps.

With regard to timeliness, sending telemetry data from TEL IV down range to JDMTA so it can be processed through TGRS is the most challenging because TEL IV must meet the timeliness requirements of a launch head sensor. The data latency of the GPS state vectors received by TEL IV is estimated to be 250 milliseconds for the landline data link and 267 milliseconds using the microwave system. The launch head timeliness requirement of 400 milliseconds is thus met.

The backward compatibility requirement needs to be viewed from a network perspective. Interfaces are currently defined by the legacy serial data format rather than by the actual communications network. Addressing these legacy interface requirements was done at the project level by the radar team, rather than with a re-look at the range system, resulting in an extra 260 milliseconds of data latency. With the growing dependence on telemetry, and the importance of data timeliness, the interfaces need to be considered carefully.

D. SUMMARY

This thesis takes the range as a weapon system point-of-view and focuses on data availability and timeliness to meet the range safety requirements, which are derived from the basic need to protect the public and range personnel. The range is also required to perform many Automated Information Systems functions which demand far more bandwidth than the range safety functions, whose timeliness is less critical.

From a network perspective there is ample bandwidth to meet the range requirements. Moving to an IPv6 based network will not have a significant impact on the available bandwidth, assuming the existing cables and fibers are used. The most significant bandwidth limitation is the commercially leased data link from the core to JDMTA. The link cannot carry the entire stream of telemetry data, so the portion carrying the GPS data needs to be separated. After the change to using GPS for all vehicles, data timeliness requirements can be met with the current network or an IPv6 based network. Data timeliness needs to be considered carefully in so far as it is affected by the location of the TGRS. Additionally, there exists the potential to improve timeliness by examining the need to maintain legacy communication standards.

IV. CONCLUSIONS AND RECOMMENDATIONS

A. CONCLUSIONS

Answering research question 1 (Question 1: Should the Spacelift Ranges migrate their data networks to an IPv6 standard as proposed by the Future Range Architecture Team?): Both the current range network and an IPv6 based network would satisfy the data availability and timeliness requirements for range safety after the change to using GPS metric tracking for all vehicles.

From an availability point of view, range safety data is less than 8% of the network data load. The factors treated as steady-state background traffic place a much greater demand on the data network capacity. This background traffic is estimated to be 36% of the available network capacity using the legacy systems and 57% if various modernized systems (e.g., voice over IP, IP based video) are used. As for capacity to add and remove data from the core, range safety uses at most 13% of the available capacity, which is driven by large volumes of telemetry data. Again there is ample bandwidth available for systems like voice over IP and IP based video.

There are reasons beyond meeting the range safety requirements that make the migration to an IPv6 standard a reasonable course of action. The network is important to interoperability and the ease with which modernized sensors can be accepted on to the range. With the wide acceptance of the IP packetized data, it is likely that modernized components would favor the IP standard. The ROSA radar, voice over IP, and IP based video are examples. Additionally, compliance with DoD Joint Technical Architecture calls for using IPv6 (FRAT, 2007). Besides the interoperability requirements, there is a need to address the sustainability of the legacy network, which is considered to be unsupportable (Laird, 2008).

Answering research question 2 (Question 2: In modernizing the range data network, is it more advantageous to make legacy components forward compatible or to make modern components backward compatible?): Currently, the range uses both

approaches suggested in question 2. Legacy components employ middleware for use with the relatively new data network and modern components are backward compatible to legacy data formats (e.g., ROSA radars). Since current practices have demonstrated the feasibility of making legacy sensors forward compatible, the range should move toward a strategy of making modern systems compatible with a modern network infrastructure rather than forcing compatibility to legacy formats. Legacy formats, like the 240-bit data frame are not amenable to transport on the current data network, which transfers T-1 size data frames. Defining system interfaces that produce data in a form that can be transported by the network, irrespective of how it evolves, is an important step in modernizing the range.

B. RECOMMENDATIONS

The backward compatibility strategy should be reviewed with a systems perspective starting with the interface control documents. Particular attention should be paid to data input and output rates and formats. If a device requires input in a legacy data format, it needs to be used with middleware to convert data from the format used by the core network, because the legacy formats cannot be used directly on the network. Making a system that is inherently compatible with the range network convert its output to a legacy format is unnecessary because that data is reformatted for transport on the network. If the requirement for the legacy data standards is driven by other ranges that need to interface with the launch ranges, the issue may need to be brought to the Range Commanders' Council. Emphasis should be on putting the middleware at the device that consumes legacy formatted data rather than at the device that produces it.

C. AREAS OF FURTHER RESEARCH

The range has a significant network bandwidth demand for video that far exceeds the network bandwidth demands of the range safety requirements (Gillis, 2008). The range also records telemetry data for later analysis and archives other data. Arguably the range is basically an Automated Information System, which probably led to the ORD requirement for the range to be DoD GIG compliant. (Headquarters Air Force Space

Command, DRSR, 2003, Section 1.4.3.3). The range is also a real time sensor network with strict range safety timing requirements. Can these functions both be optimized on the same network? Does the AIS need for accessibility create vulnerabilities to the sensor net side? The current practice of using a dedicated command destruct circuit seems to be a reaction to such concerns.

Another consideration is the extent to which some data, like telemetry data, is both range safety and customer data. For some operations the entire telemetry stream needs to be handled by the range safety systems to extract the data they need. This is the same telemetry data the customer wants. The Publish/Subscribe model appears to be able to handle a variety of subscriptions with a hierarchy of priority. This may allow both functions to work well together on the same network, especially if the telemetry data comes from the vehicle formatted in IP packets. The correct Quality of Service parameters could address the reliability requirements for range safety and the large network sized for AIS functions would have ample performance.

There appears to be room for improving timeliness by examining the need to maintain legacy communications standards. The emphasis should be on interoperability with the network, rather than between the devices that produce data and the ones that consume it. Getting data from one to the other demands network compatibility, so the interface requirements need to reflect that. Further study along these lines should be done within the launch range and among all the ranges that need to interoperate.

THIS PAGE INTENTIONALLY LEFT BLANK

LIST OF REFERENCES

- Allen, E.W. (1994). Measured time delay and re-synchronization time in digital microwave radio systems. *IEEE transactions on power delivery* ISSN 0885-8977 CODEN ITPDE5. Institute of Electrical and Electronics Engineers, New York, NY. Retrieved July 14, 2008, from <http://cat.inist.fr>
- Blanchard, B. S. & Fabrycky, W. J., (2005). *Systems engineering and analysis*, 4th edition. Prentice-Hall International Series in Industrial and Systems.
- Bryant, D. (2008, June 25). Private communication.
- Computer Sciences Raytheon [CSR]. (2008). Eastern Range Capabilities Documentation Retrieved July 7, 2008, from https://imis.rc.patrick.af.mil/imis3/Cap_doc/MAIN_1024.htm
- Corsaro, A., Querzoni, L., Scipioni, S., Tucci Piergiovanni, S., & Virgillito, A. (2006). Quality of service in publish/subscribe middleware. *Global Data Management*, IOS Press. Retrieved December 19, 2007, from Washington University in St. Louis, School of Engineering, <http://www.cse.wustl.edu>
- Davis, B. (Space Lift Range System Contractor). (2008, May 15). OV-06x Lvl 3 MFCC, DoL – Non-nominal (OV-06x Activity Sequence (ISS)) [Engineering Drawing].
- Department of Defense. (2007, April 23). *DoD architecture framework Ver. 1.5, Vol. II: Product Descriptions*. Retrieved May 28, 2008, from Online Journal, hosted on the DoD Architecture Registry System (DARS) website <https://dars1.army.mil>
- Future Range Architecture Team. (2007, September 5). *Detailed Presentation to: AFSPC* [where AFSPC is Air Force Space Command, Department of the Air Force] *Staff, 5 Sep 07* [Slides].
- Gillis, J., & Orlando, W., (2007, May). *CSR Technical Training Orientation: Eastern Range Communications Systems* [Slides].
- Gillis, J. (2008, July 14). Private communications.
- Gorlick, M. (2008, June 30). Private communications.
- Headquarters Air Force Space Command, A3RS [Department of the Air Force]. (2007). *Enabling Concepts for Launch and Test Ranges*.
- Headquarters Air Force Space Command, DRSR [Department of the Air Force]. (2003, April 10). Operational Requirements Document for AFSPC 022-91-I/II/III-B Launch and Test Range System (LTRS) Modernization, Milestone C, ACAT Level II.

- Laird, B. (2008, July 21). Private communications.
- Morton, H. (2008, July 15). Private communications.
- Object Management Group. (2007, January 1). *Data distribution for real-time systems Ver. 1.2. OMG [Object Management Group] Available Specification formal/07-01-01*. Retrieved April 3, 2008, from OMG main web page: <http://www.omg.org>
- Osmundson, J.S., & Huynh, T.V. (2005). A systems engineering methodology for analyzing systems of systems. 1st Annual System of Systems Engineering Conference Proceedings, Johnstown, PA, June 13-14, 2005. Retrieved December 19, 2007, from System of Systems Engineering Center of Excellence <http://www.sosece.org>
- Richards, J. (2008, July 27). Private communications.
- Shappell, A, Colonel U.S. Air Force AFSPC/A3R [Department of the Air Force]. (2008, April 8). *Spacelift Range Roadmap* [Slides].
- Smith, L. (2008, July 10). Private communications.
- Smith, L. (2008, August 8). Private communications.
- Space Lift Range System Contractor. (2004, August 16). Post-detect telemetry subsystem (PDTs) WANIU Time data correlation and latency performance characterization. NON-CDRL N119, Document No. 04-10648, Spacelift Range System Contract Number F04701-01-C-0001.
- Space Lift Range System Contractor. (2005, April 7). Draft configuration item product specification for the radar controller (RDC). CDRL A021, Document No. 04-09716, Spacelift Range System Contract Number F04701-01-C-0001.
- Space Lift Range System Contractor. (2007, January 25). PDF formatted drawing excerpt from Space Lift Range OV-5 DRAFT [Engineering Drawing]. Spacelift Range System Contract Number F04701-01-C-0001
- Space Lift Range System Contractor. (2007, May 2). 5/02/07 Circuit Layout CKT# CORE-AGG. VSD Spacelift Range System Contract Number F04701-01-C-0001.
- Spacelift Range Group of the Launch and Ranges Systems Wing, Space and Missile Systems Center [Department of the Air Force] (2008, March 8). *Spacelift Range Roadmap* [Slides].
- Thomas, G. (2008, June 24). Private communications.

INITIAL DISTRIBUTION LIST

1. Defense Technical Information Center
Ft. Belvoir, Virginia
2. Dudley Knox Library
Naval Postgraduate School
Monterey, California
3. SMC/EA
Space and Missile Systems Center
Los Angeles AFB, California
4. SLG/LRL
Space Logistics Group, Spacelift Ranges Division
Peterson AFB, Colorado