

Implementing a multiplexed system of detectors for higher photon counting rates

Valentina Schettini, Sergey V. Polyakov, Ivo Pietro Degiovanni, Giorgio Brida, Stefania Castelletto, and Alan Migdall

Abstract—Photon counting applications are typically limited by detector deadtime to operate at count rates of a few MHz, at best, and often at significantly lower levels. This limitation is becoming more critical with the advance of photon counting applications such as photon-based quantum information. We present a first experimental proof of principle and review the theoretical foundation of a multiplexed detection scheme that allows photons to be counted at higher rates than is possible with individual detectors or simple detector trees. In addition to this deadtime improvement, we discuss the impact of this scheme on other relevant characteristics such as afterpulsing and dark count rates.

Index Terms—photon counting, multiplexing, InGaAs single photon avalanche detector, parametric down-conversion, fast fiber switch.

I. INTRODUCTION

QUANTUM communication and quantum computation applications place difficult design requirements on the manipulation and processing of single photons [1], [2]. Quantum cryptography [3] would particularly benefit from improved detectors, as that application in the form of Quantum Key Distribution (QKD), is often constrained by detector characteristics such as detection efficiency (DE), dark count rate, timing jitter, and deadtime [4]. Because of demands for higher-rate secret key production, the quantum information community is presently engaged in efforts aimed at improving QKD, including reducing detector deadtime [5]. Moreover, with the exponential growth in multimode parametric down-conversion (PDC) photon pair production rates [6] that are now in the range of $2 \cdot 10^6 \text{ s}^{-1}$ and the more recent development of $\chi^{(3)}$ single-mode fiber-based sources with pair rates [7], [8] up to 10^7 s^{-1} , the need is clear for faster photon-counting detection. In typical single photon detectors presently available, either commercial or prototype, the deadtimes range from $\approx 50 \text{ ns}$ for actively quenched single photon avalanche detectors (SPADs), to $\approx 10 \mu\text{s}$ for passively quenched SPADs, although even actively quenched SPADs sometimes employ μs deadtimes to avoid excessive afterpulsing rates. In addition to the absolute limits imposed by these effects, in practice

detectors are often limited to small fractions of these rates to $\approx 1 \text{ MHz}$ or much less to avoid undesirable systematic effects associated with high deadtime fractions. This is particularly the case for infrared SPADs, which are especially prone to high afterpulsing. Additional motivation for improved photon counters are traditional low light detection applications such as medical diagnosis, and bioluminescence, chemical, and material analyses, where high speed and time resolution are also required [9], [10], [11], [12].

We have previously introduced a scheme to improve detection rate limits by taking a pool of photon-counting detectors and operating them as a unit [13]. We now implement a simple prototype system. The general scheme consists of a 1-by- N optical switch that takes a single input stream of photons and distributes them to members of an array of N detectors. A switch controller monitors which detectors have fired recently and are thus dead, and then routes subsequent incoming pulses to a detector that is ready. We have previously shown that this scheme allows a system of N detectors to be operated at a significantly higher detection rate than N times the detection rate of an individual detector, while maintaining the same Dead Time Fraction (DTF).

The system's switching operation could be sequential with each detector firing in order, or it could be set up to direct the input to any live detector. Ultimately the scheme could be implemented to allow for optimum use of an array of detectors where each detector may have a different deadtime, dark count rate, and/or afterpulsing probability. In addition, optical switch loss and switching time may also be included in the optimization. For example, a system using a switch with a significant latency time (perhaps due to long processing times to determine if a detector has fired) might benefit from operation in a mode where, for a pulsed source, the input is switched to another live detector regardless of whether the previous detector fired. This would reduce the effect of the long latency as long as there is a high likelihood of there being at least one available live detector.

Our original analysis quantified the advantage of the scheme for the ideal case of a multiplexed system with zero switch transition time [13]. Our subsequent effort [14] including the effect of a nonzero switch time, showed that for switch times as high as 10% of the individual detector deadtimes, there was still significant advantage to be gained with this scheme. (We also note that the finite switch time model coincides with our previous calculations in the limit of switching time negligible compared to the single detector deadtime, as it should.)

The main focus of this paper is an experimental verification

Giorgio Brida, Stefania Castelletto, Ivo Pietro Degiovanni, and Valentina Schettini are with Istituto Nazionale di Ricerca Metrologica, Strada delle Cacce 91, 10135 Torino Italy

Alan Migdall and Sergey V. Polyakov are with the Optical Technology Division, National Institute of Standards and Technology, Gaithersburg, Maryland 20899-8441, USA and Joint Quantum Institute, University of Maryland, College Park, MD, 20742, USA

Send correspondence to Alan Migdall, E-mail: migdall@nist.gov, Telephone: 001 301 975 2331

Manuscript received May 16, 2007; revised June 6, 2007.

Report Documentation Page

Form Approved
OMB No. 0704-0188

Public reporting burden for the collection of information is estimated to average 1 hour per response, including the time for reviewing instructions, searching existing data sources, gathering and maintaining the data needed, and completing and reviewing the collection of information. Send comments regarding this burden estimate or any other aspect of this collection of information, including suggestions for reducing this burden, to Washington Headquarters Services, Directorate for Information Operations and Reports, 1215 Jefferson Davis Highway, Suite 1204, Arlington VA 22202-4302. Respondents should be aware that notwithstanding any other provision of law, no person shall be subject to a penalty for failing to comply with a collection of information if it does not display a currently valid OMB control number.

1. REPORT DATE 2007	2. REPORT TYPE	3. DATES COVERED 00-00-2007 to 00-00-2007	
4. TITLE AND SUBTITLE Implementing a Multiplexed System of Detectors for Higher Photon Counting Rates		5a. CONTRACT NUMBER	
		5b. GRANT NUMBER	
		5c. PROGRAM ELEMENT NUMBER	
6. AUTHOR(S)		5d. PROJECT NUMBER	
		5e. TASK NUMBER	
		5f. WORK UNIT NUMBER	
7. PERFORMING ORGANIZATION NAME(S) AND ADDRESS(ES) NIST,100 Bureau Dr., STOP 8441,Gaithersburg,MD,20899		8. PERFORMING ORGANIZATION REPORT NUMBER ; 45116.115-PH-MUR	
9. SPONSORING/MONITORING AGENCY NAME(S) AND ADDRESS(ES) U.S. Army Research Office, P.O. Box 12211, Research Triangle Park, NC, 27709-2211		10. SPONSOR/MONITOR'S ACRONYM(S)	
		11. SPONSOR/MONITOR'S REPORT NUMBER(S) 45116.115-PH-MUR	
12. DISTRIBUTION/AVAILABILITY STATEMENT Approved for public release; distribution unlimited			
13. SUPPLEMENTARY NOTES Federal Purpose Rights			
14. ABSTRACT			
15. SUBJECT TERMS			
16. SECURITY CLASSIFICATION OF:			17. LIMITATION OF ABSTRACT
a. REPORT unclassified	b. ABSTRACT unclassified	c. THIS PAGE unclassified	Same as Report (SAR)
			18. NUMBER OF PAGES 6
			19a. NAME OF RESPONSIBLE PERSON

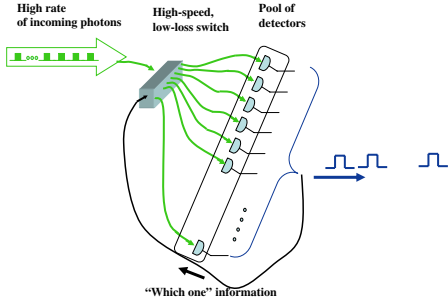

Fig. 1. A pool of detectors and a fast optical switch are used to register a high rate of incoming photons. Incoming photons are switched to a ready detector. If it fires, the detector is switched out of the ready pool until recovery. If it does not fire, that detector remains ready.

of a theoretical finding that the controlled arrangement of multiple detectors yields a significant improvement of DTF, and other characteristics of a photon counting apparatus. We present the experimental comparative study of performance of various detector arrangements with one or two detectors. We show experimentally that the most advantageous scheme to reduce DTF and increase photon count rates, along with the added bonus of improving the signal to background ratio and reducing afterpulsing, is the active switching arrangement that uses an external logic control circuit that remembers the order in which the detectors fired.

II. THEORY

A. Analytical modeling

Our analytical calculations have been previously presented, so here we only briefly describe key definitions and results [13], [14]. The DTF of a generic photon counting detector is defined as the ratio of the lost count rate over the total count rate in the absence of deadtime:

$$\text{DTF} = \frac{\lambda - \lambda_{\text{registered}}}{\lambda} = 1 - \frac{1}{1 + \lambda T_d}, \quad (1)$$

where $\lambda_{\text{registered}}$ is the count rate registered by a real detector, λ is the count rate of an idealized detector with no deadtime (assuming Poissonian count statistics), T_d is the individual detector deadtime, and $T \gg T_d$ is the measurement time.

To generalize this definition to a system of N detectors, we introduce an overall or "effective" deadtime $\mathcal{T}_{d(N)}$ with the DTF of the system being:

$$\text{DTF} = 1 - \frac{1}{1 + \lambda \mathcal{T}_{d(N)}}. \quad (2)$$

To simply highlight the advantage of an N -detector system, we compare its DTF to what could be achieved by a single detector with a deadtime reduced by a factor of $1/N$. For such an improved single detector, $\text{DTF} = 1 - 1/(1 + \lambda T_d/N)$. This is the same result that would be obtained by an array of N detectors with deadtime T_d and random switching such as may be implemented with a tree arrangement of beam splitters [15], [16], [17].

We now calculate $\mathcal{T}_{d(N)}$. Because in the scheme here the optical switch only switches photons to a new detector after a registered count, the effective deadtime can be given by statistically combining the effects of switching time, T_s and the single detector deadtime, T_d , governed by two cases- either a) N events are counted in a time interval bigger than $T_d - T_s$ (i.e. one event for each detector), or b) they occur in a time interval less than $T_d - T_s$. In the second case, the photon is switched to a dead detector adding an additional delay to the optical switching time. Following our previous work [13], we write the effective deadtime for N detectors as

$$\mathcal{T}_{d(N)} = p_{a,N}(\mathcal{T}_{d(N)})T_s + p_{b,N}(\mathcal{T}_{d(N)})(T_d - E_{b,N}(\mathcal{T}_{d(N)})), \quad (3)$$

where

$$p_{a,N}(\mathcal{T}_{d(N)}) = \int_{T_d - T_s}^{+\infty} f_N(\Delta t, \mathcal{T}_{d(N)}) d\Delta t, \quad (4)$$

and

$$p_{b,N}(\mathcal{T}_{d(N)}) = \int_0^{T_d - T_s} f_N(\Delta t, \mathcal{T}_{d(N)}) d\Delta t, \quad (5)$$

are the probabilities that case (a) or (b) occurs for $f_N(\Delta t, \mathcal{T}_{d(N)})$, the probability density distribution of the time interval Δt , between a count and the $(N - 1)^{\text{th}}$ preceding one. We indicate the dependence of the above probabilities on $\mathcal{T}_{d(N)}$, with

$$E_{b,N}(\mathcal{T}_{d(N)}) = \frac{\int_0^{T_d - T_s} \Delta t f_N(\Delta t, \mathcal{T}_{d(N)}) d\Delta t}{\int_0^{T_d - T_s} f_N(\Delta t, \mathcal{T}_{d(N)}) d\Delta t}, \quad (6)$$

which is the mean time interval between a count and the $(N - 1)^{\text{th}}$ preceding one when case (b) occurs. For a poissonian process where events are counted with an overall deadtime of fixed length $\mathcal{T}_{d(N)}$, $f_N(\Delta t, \mathcal{T}_{d(N)})$ is given by [18]

$$f_N(\Delta t, \mathcal{T}_{d(N)}) = \frac{\lambda^{N-1} [\Delta t - (N - 1)\mathcal{T}_{d(N)}]^{N-2}}{(N - 2)!} \times e^{-\lambda[\Delta t - (N-1)\mathcal{T}_{d(N)}]} \theta[\Delta t - (N - 1)\mathcal{T}_{d(N)}], \quad (7)$$

which is a modified Gamma function, and θ is the Heaviside step function with $\theta(x) = 1$ for $x > 0$ and 0 otherwise. In our previous work [13] where the switching time was neglected, an explicit formula for the effective deadtime was possible. Due to added complexities related to the non-negligible switching times, an analytical formula exists only for $N = 2$ detectors:

$$\mathcal{T}_{d(2)} = \frac{T_d}{2} - \frac{1 + 2 W\left[\frac{(2T_s - T_d)\lambda - 1}{2}\right]}{2\lambda}, \quad (8)$$

where W is the principal value of the Lambert W -function [19]. For more detectors we must use numerical methods. This theoretical approach is also in excellent agreement with Monte-Carlo simulation results [14].

B. Modeling results

The analysis above allows a comparison of multiple detector arrangements with realistic deadtimes and switching times (Fig. 2). We have assumed $T_d = 10 \mu\text{s}$, which is implemented

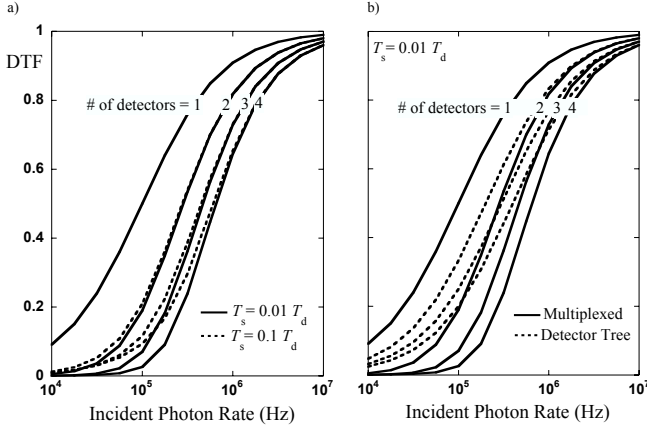

Fig. 2. DTF of multiplexed SPAD systems (a) DTF as a function of incident photon rate for actively switched systems with up to 4 detectors for $T_s = 0.01T_d$ and $0.1T_d$; (b) comparing actively switched assemblies with $T_s = 0.01T_d$ to detector trees shows higher photon rates can be reached at a given DTF.

in the experiment. It is clear from Fig. 2(a) that the smaller the fraction of time needed to switch the detectors, the lower the DTF achievable at the same rate of incident photons. In particular, we compare the case when the characteristic switching time $T_s = 0.01T_d$ (which is readily achievable with fast, albeit lossy, available commercial optical switches) to a more modest switching time of $T_s = 0.1T_d$ that allows for slower switches that can have significantly lower loss. Clearly, longer switching time results in lower incident photon rates for a given DTF value, and this effect becomes more evident when more detectors are used in the assembly [14].

Theory predicts that an actively multiplexed arrangement compares favorably to a detector tree configuration, for realistic ratios between deadtime and switching time, Fig. 2(b). We see that a multiplexed SPAD arrangement dramatically lowers DTF and that improvement increases with the number of detectors used.

While the model here only deals with the DTF improvement, it is important to note other advantages of active multiplexing. The most significant advantage is reduction in afterpulse counts, because the SPAD is switched off immediately after it detects a photon, and is not switched on until all other detectors detect one photon each. Therefore, the probability of a set of N detectors to register an afterpulse is much less than that of one detector. At the same time, the rate of dark counts is expected to be equal to a mean of dark count rates of all detectors used rather than the sum of the rates, because at all times only the output of the one active detector is recorded.

C. Modeling the experimental system

For our heralded photon test system the experimental value of DTF is calculated as $\text{DTF} = 1 - \lambda_{\text{gate}}/\lambda_{\text{heralding}}$, where $\lambda_{\text{heralding}}$ is the rate of heralding counts, and λ_{gate} is the rate of those heralding counts that are accepted by our multiplexed detection system and result in a gate pulse. DTF is calculated

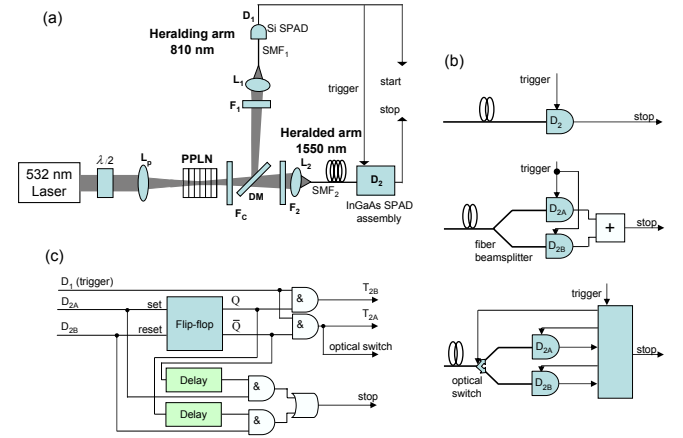

Fig. 3. (a) Setup for testing different arrangements of InGaAs SPAD assemblies; (b) three different InGaAs SPAD assemblies; (c) schematic of electronic logic to actively control InGaAs assemblies and photon routing.

this way because λ_{gate} is a readily available measure of heralding counts accepted by the detector system (the gate counts sent to our detection system). We have assumed Poissonian behavior of our heralded single-photon source.

These experimental data are compared to theoretical values. In general, the theoretical formula used for the estimation of the DTF is

$$\text{DTF} = \lambda_{\text{registered}}T_d + (\lambda_{\text{gate}} - \lambda_{\text{registered}})T_0, \quad (9)$$

where $\lambda_{\text{registered}}$ is now the overall rate of counts registered by our specific detection system and T_0 is the time interval during which our detection system is busy after a gate pulse is received. (Note: it is important to distinguish the two rates, $\lambda_{\text{registered}}$ and λ_{gate} , because not all the pulses produced by the detector used for gating yield a herald pulse, as the electronic logic circuit may be busy. Note also that as opposed to T_d , which is the deadtime of the detector after it registers a count, T_0 is the deadtime of the detector electronics when it does not register a count.) We estimated $T_0 \simeq 220$ ns. The first term of the formula corresponds to our original theoretical model, while the second term accounts for the previously unconsidered effect of T_0 . When our detection system is just one detector $T_d = T_d$ (5 or 10 μs), while for the detector tree $T_d = T_d/2$. For the system where the SPADs are controlled by the external logic circuit, we evaluate T_d numerically using Eq. (8), where $T_s \simeq 130$ ns, and λ , the count rate in the absence of deadtime, is evaluated as $\lambda_{\text{registered}}/(1 - \lambda_{\text{registered}}T_d)$.

III. EXPERIMENT

A. Experimental Setup

We chose to test the deadtime reduction scheme with an InGaAs detector which typically requires long deadtimes after firing to avoid excessive afterpulsing. The long deadtimes (≈ 10 μs) ease the engineering involved in switching the optical channel in a time short relative to the deadtime. For these tests we produced correlated photons at 810 nm and 1550 nm (Fig. 3a) by pumping a 5 mm long periodically poled MgO-doped lithium niobate (PPLN) crystal with a continuous

wave laser at 532 nm [20]. The visible photons are used to herald the IR photon's arrival at the InGaAs detector. We used noncritical phase-matching (90° phase-matching angle) with a $7.36 \mu\text{m}$ poling period to satisfy phase matching conditions for photon pairs at external angles of 1° (for 810 nm photons) and 2° (for 1550 nm photons). We fine tuned the phasematching angles by adjusting the crystal temperature near 131°C . Lens L_p focused the pump beam in the PPLN crystal; cutoff filter F_C blocked the pump laser; and dichroic mirror DM separated the 810 nm (beam 1) and 1550 nm (beam 2) photons. An extra interference filter (F_1) at 810 nm with a full width half-maximum (FWHM) of 10 nm further suppressed fluorescence from the PPLN crystal reducing background heralding counts. $L_{1,2}$ were aspheric coupling lenses with 8 mm focal lengths, antireflection-coated for 810 nm and 1550 nm. The single-mode fiber (SMF) collection geometry (with the crystal to L_1 distance of 27 cm) restricted the heralding bandwidth to ≈ 2 nm FWHM [20]. The distance between the crystal and L_2 was 20 cm, with a spectral filter F_2 with a 30 nm pass band FWHM installed in the path. The heralding arm was routed to a SMF and then to D_1 , a Si SPAD, while the heralded arm also coupled to a SMF, was sent to an InGaAs SPAD assembly. The InGaAs assemblies were operated in gated mode with gate pulses provided by photodetection events of D_1 . Both optical and electronic delays of the heralded arm were adjusted with appropriate length SMF and electronic cables.

The following InGaAs SPAD assemblies were tested (Fig. 3b): (i) a single InGaAs SPAD (ii) a pair of InGaAs detectors in a tree configuration, connected to the PDC source via a fiber beam splitter (FBS), and (iii) a pair of InGaAs detectors actively controlled by external logic [13]. The logic block was designed to trigger only one of the two detectors at a time and to change which detector is triggered once the first one registered a count. This algorithm not only decreases the deadtime fraction, but also improves the signal to noise ratio, and dramatically reduces afterpulsing. The same logic block can operate a fast optical switch to route a photon to an active detector. The schematic of the logic block is shown in Fig. 3c. The main logic element is an asynchronous set-reset flip-flop. Its state represents which detector fired most recently. Therefore, trigger pulses from a Si SPAD are only routed to the detector which has had more time to recover. A fast optical switch with a sub-ns response time is controlled in a similar manner. The actual switching time is determined by the switching time of electronics, which was equal to 1 ns. Because the switch's resistance is 40Ω and requires ≈ 5 V to switch the output, one needs to limit the duration of the voltage applied to avoid thermal effects. Therefore, we gated the switch control voltage synchronously with the Si SPAD trigger pulse. The electronic delays, together with logic primitives, are arranged so that the active detector can register one count and only one count, with the output(s) of the other detector(s) being blocked.

B. Experimental Results

Our experiment compares the DTF as a function of the trigger detector rate (proportional to the incident photon rate)

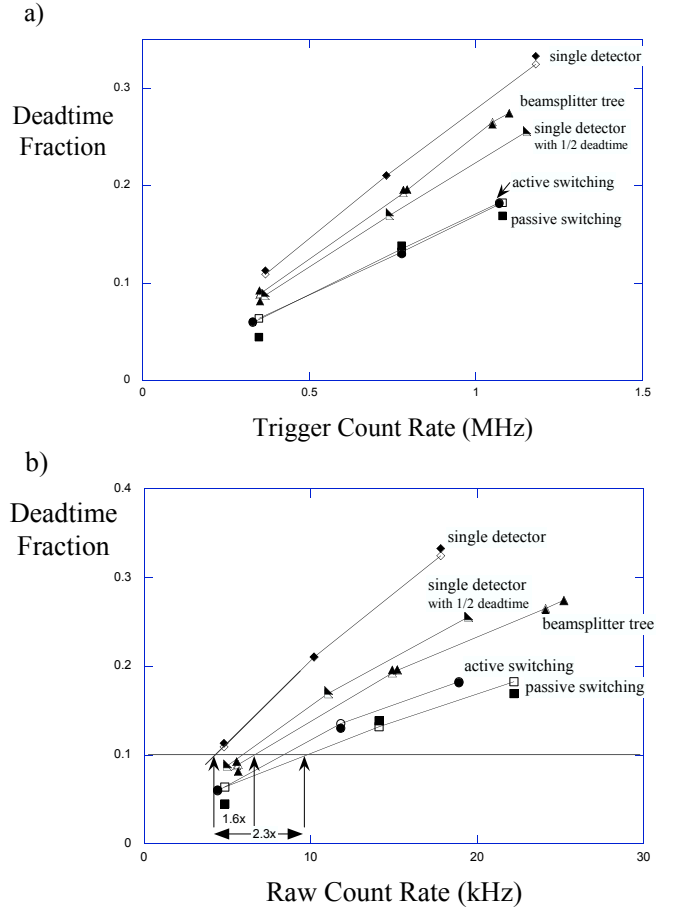

Fig. 4. (a) DTF as a function of trigger detector count rate ($\lambda_{\text{heralding}}$) for each detector system configuration. Measured (solid points) and calculated (open points connected by lines to guide the eye) deadtime fractions are shown. All configurations used $10 \mu\text{s}$ deadtime detectors except the one indicated with deadtime reduced by half. (b) same as in (a), except plotted versus the count rate of InGaAs arrangements.

for the three detector configurations just discussed. To clearly illustrate the effects of these different configurations on the DTF, the deadtimes of the individual InGaAs detectors were kept constant at $10 \mu\text{s}$. Further, for comparison purposes, overall detection efficiencies of all the InGaAs arrangements were kept equal (to within 7% relative variation) by introducing appropriate attenuation to the heralded arm's fiber channel. Because of limitations of our PDC photon source, we could not experimentally measure the DTF for trigger photon rates of $> 10^6$ Hz. However, based on the theoretical treatment above, the most dramatic difference between the curves is expected at trigger rates $< 10^6$ Hz. Experimental results and the corresponding theoretical values are presented in Fig. 4. Note that the calculated DTFs, based on Eqs. (8, 9), used only experimentally determined parameters (i.e. no free fit parameters were used). We see that a single InGaAs detector exhibits the largest DTF, and it increases with trigger detector rate, in agreement with the theoretical predictions. We see that the DTF achieved by the tree consisting of two InGaAs detectors is lower than the DTF of a single InGaAs

detector with the same deadtime. While we might expect that the DTF of the tree would be equal to the DTF of a single detector with *half* the deadtime, in practice the tree performance is slightly worse. This is because the two InGaAs detectors differ in their detection efficiencies and afterpulsing probabilities. In addition, for the tree arrangement the system dark count and afterpulse rates are the sum of the individual rates. This suggests that in arrangements with $N > 2$ detectors, the controlled triggering arrangement offers opportunities for additional advantages over the simple tree arrangement, with respect to detection efficiency, afterpulse probability, and dark count rates. Finally, the arrangement with a pair of detectors controlled by external logic has the lowest DTF, because only the output of the detector which has the best chance to be “alive” is recorded. To highlight the advantage of the multiplexed scheme two experimental data sets are presented. One with a beamsplitter acting as passive switch (and introducing 50% loss) and one with an active optical switch. Note that the optical loss in the previous arrangements was matched to the passive switched arrangement so the passive switch DTF results are directly comparable to a single detector and a detector tree. In a separate experiment, we showed that active routing of a photon to the detector that is expected to be alive increases the overall DE, while keeping the DTF low.

To demonstrate the advantage and the feasibility of active routing of photons, we made a series of DE measurements at different trigger detector rates using the logic module with a beam splitter versus an active switch and observed a $(28 \pm 3)\%$ increase in DE, while ideal lossless active photon routing would have resulted in a 100% increase. This rather moderate DE increase is due to relatively high insertion loss of our switch (≈ 2 dB) rather than any other switch or control circuit nonidealities. Obviously, the DE of the system can be improved by using less lossy fast switches. The DTF for the active switching case is also shown in Fig. 4a. We see that the DTF for an active switching scheme changes insignificantly, compared to a “passive switch” case. However, strictly speaking, it can not be compared directly to any other configurations shown in Fig. 4a, because its DE is different from all the other InGaAs arrangements.

We note that using the logic circuit to activate only one detector improves the signal to background ratio as compared to the detector tree arrangement or even compared to a single detector with half the deadtime. We gauged the signal to background improvement relative to the detector tree for cases of passive and active switching. The passive scheme improvement was 1.83 ± 0.05 , while the active scheme improvement was 2.0 ± 0.1 . We also gauged the improvement of our switching schemes to a single detector with a deadtime reduced by half and found improvement factors of 1.3 ± 0.1 and 1.4 ± 0.2 , for the two cases respectively. It is also evident from our experiments that the afterpulsing peak is significantly reduced with the controlled switch system, because in most cases after registering a count the detectors remain off for much longer times than their individual deadtime.

Fig. 4b shows that the observed decrease in DTF at a fixed trigger count rate allows operation at higher registered count rates, while maintaining the same value of DTF. Indeed, we

see that the registered count rate of the single detector with $10\mu\text{s}$ deadtime is 4.2 kHz for a DTF of 0.1. A detector tree yields a 6.7 kHz count rate at this DTF. Finally, with the controlled switch configuration, the registered count rate can be increased to 9.9 kHz for the same DTF value. As discussed, this comparison is made for the detector arrangements after equalizing their DEs to ensure equivalent conditions. Note that in this case (Fig. 4b) the DTF values for a tree arrangement fall lower than the DTF values for a single detector with half the deadtime, when plotted against the registered count rate, while the situation is reversed when plotted against the trigger count rate (Fig. 4a). The reason for this effect is that in our experiment we recorded the sum of the two detectors outputs in a tree configuration, i.e. both detectors could fire during the same trigger cycle, and both detections would be recorded by our electronics, thus this increase of the raw count rate for the same DTF is only due to an increase in background counts which consist of real photon detections (due to multiple photons emitted with a detector gate time), as well as dark counts, after pulses, etc.. This behavior is evident at higher rates, when the rate of raw counts for a tree arrangement is significantly higher than that for all the other arrangements, while the trigger count rate was kept approximately equal for all arrangements tested.

IV. CONCLUSION

We have presented a proof of principle experiment showing that a pool of N detectors with controlled switching exhibits lower DTF as compared to passive arrangements, and therefore can be operated at much higher incident photon rates than is otherwise possible, either with an array of detectors with a passive switch system such as might be implemented with by a tree of beamsplitters or a single detector with much reduced deadtime. We see that in addition to higher count rates, characteristics important for detection of single-photons such as signal to background ratio and afterpulsing favor actively controllable switch systems. We conclude that because parameters such as DE, dark count rate, and afterpulse probability can vary from one detector to the next, it may be possible to design the active switching to minimize the overall noise and maximize the overall signal by using the worst detectors as rarely as possible. Overall this optimization can be a complicated procedure involving not just the numerous characteristics of the numerous detectors, but also the optical switch characteristics, as well as the requirements of the particular photon counting application. This effort, while beyond the scope of this paper, should be pursued in developing this technique.

ACKNOWLEDGMENT

This work was supported in part by the Disruptive Technology Office and the Army Research Office.

REFERENCES

- [1] A. Migdall and J. Dowling, Editors, “Introduction for JMO Special Issue on Single Photon: Detectors, Applications, and Measurements Method,” *Special Issue on Single Photon Detectors to J. Mod. Opt.*, vol. 51, pp. 1265-1266, 2004.

- [2] P. Kumar, P. Kwiat, A. Migdall, S. Nam, J. Vuckovic, and F. N. C. Wong, "Photonic Technologies for Quantum Information Processing," *Quantum Inf. Processing*, vol. 3, pp. 215-231, 2004.
- [3] C. H. Bennett and G. Brassard, "Quantum cryptography: Public key distribution and coin tossing," *Proceedings of IEEE International Conference on Computers, Systems, and Signal Processing, Bangalore, India*, pp. 175-179, 1984.
- [4] N. Gisin, G. Ribordy, W. Tittel and H. Zbinden, "Quantum Cryptography," *Rev. Mod. Phys.*, vol. 74, pp. 145-195, 2002.
- [5] A. Rochas, P. Besse, and R. Popovic, "Actively recharged single photon counting avalanche CMOS photodiode in an industrial CMOS process," *Sens. actuators, A Phys.*, vol. 110, pp. 124-129, 2004.
- [6] P. G. Kwiat, J. B. Altepeter, J. T. Berreiro, M. E. Goggin, E. Jeffrey, N. A. Peters, A. VanDevender, "The Conversion revolution: Down, Up and Sideways," *Quantum Communication, Measurement and Computing, AIP Conference Proceedings*, vol. 734, pp. 337-341, 2004.
- [7] J. Fulconis, O. Alibart, W. J. Wadsworth, P. St. J. Russell and J. G. Rarity, "High brightness single mode source of correlated photon pairs using Photonic crystal fiber," *Opt. Exp.*, vol. 13, pp. 7572-7582, 2005.
- [8] J. Fan, A. Migdall, "Generation of cross polarized photon pairs in a microstructure fiber with frequency-conjugate laser pump pulses," *Opt. Exp.*, vol. 13, pp. 5777-5782, 2005.
- [9] P. Finocchiaro *et al.*, "A new generation of low-voltage single photon micro-sensors with timing capability," *Nuclear Inst. and Methods in Physics Research, A*, vol. 567, pp. 83-88, 2006 and "SPAD Arrays and Micro-Optics: Towards a Real Single Photon Spectrometer," *J. Mod. Opt.*, vol. 54, pp. 199-212, 2007.
- [10] A. Restelli, I. Rech; P. Maccagnani, M. Ghioni; S. Cova, "Monolithic Matrix of 50 μ m Silicon SPAD Detectors," *J. Mod. Opt.*, vol. 54, pp. 213-223, 2007.
- [11] B. Aull, A. Loomis, D. Young, R. Heinrichs, B. Felton, P. Daniels, and D. Landers, "Geiger-Mode Avalanche Photodiodes for Three- Dimensional Imaging," *Lincoln Lab. J.*, vol. 13, pp. 335-350, 2002.
- [12] S. Tudisco *et al.*, "SINPHOS- SINGLE PHOTON spectrometer for biomedical applications," *Nucl. Phys. B-Proc. suppl.*, vol. 150, pp. 317-320, 2006.
- [13] S. A. Castelletto, I. P. Degiovanni, V. Schettini, and A. L. Migdall, "Reduced Deadtime and Higher Rate Photon-Counting Detection using a Multiplexed Detector Array," *J. Mod. Opt.*, vol. 54, pp. 337-352, 2007.
- [14] S. Castelletto, I. P. Degiovanni, A. Migdall, S. Polyakov, and V. Schettini, "Achieving higher photon counting rates using multiplexed detectors," *SPIE Quantum Communications and Quantum Imaging IV*, vol. 6305, 63050R, 2006.
- [15] P. Kok, and S. Braunstein, "Detection devices in entanglement-based optical state preparation," *Phys. Rev. A*, vol. 63, 033812, 2001.
- [16] J. Rehacek, Z. Hradil, O. Haderka, J. Perina, and M. Hamar, "Multiple-photon resolving fiber-loop detector," *Phys. Rev. A*, vol. 67, 061801, 2003.
- [17] H. Paul, P. Trma, T. Kiss, and I. Jex, "Photon chopping: New way to measure the quantum state of light," *Phys. Rev. Lett.*, vol. 76, pp. 2464-2467, 1996.
- [18] S. Castelletto, I. P. Degiovanni, and M. L. Rastello, "Theoretical aspects of photon number measurement," *Metrologia*, vol. 37, pp. 613-616, 2000.
- [19] <http://mathworld.wolfram.com/LambertW-Function.html>
- [20] S. Castelletto, I. P. Degiovanni, V. Schettini, and A. L. Migdall, "Optimizing single-photon-source heralding efficiency and detection efficiency metrology at 1550 nm using periodically poled lithium niobate," *Metrologia*, vol. 43, pp. S56-S60, 2006.

Valentina Schettini received her master degree in Physics at the University La Sapienza of Rome in 2003. In 2004 and 2005 she had a research fellowship with INRIM and she worked as a guest researcher in NIST laboratories. From January 2006 she is a PhD student in Physics at Polytechnic of Turin while continuously involved in experimental research at INRIM laboratories. Her research interests are in the field of Optical Quantum Information aiming to the realization of single photon technologies at telecom wavelengths.

Sergey V. Polyakov received his PhD in Optics from College of Optics and Photonics, CREOL, University of Central Florida, and MS in Physics (Cum Laude) from Lomonosov Moscow State University. As a post-doctoral scholar, he continued his research in the field of quantum information and atomic physics at California Institute of Technology, where he demonstrated the feasibility of an ensemble of neutral atoms to produce and store single photons and qubits. Currently, he is a member of research faculty of Joint Quantum Institute of University of Maryland and a guest researcher at NIST, Gaithersburg. His main research interest is generation, storage and detection of non-classical states of light. He authored more than 40 peer-reviewed papers and contributed to more than 50 conference presentations, including over 10 invited.

Ivo Pietro Degiovanni is a permanent researcher at INRIM from December 2005. He was awarded his PhD in Metrology at the Polytechnic of Turin in 2002. His main research interests are quantum radiometry (single-photon detector calibration), quantum information (quantum key distribution and secure quantum communication) and foundations of quantum mechanics.

Giorgio Brida Giorgio Brida was born in Aosta, Italy, in 1965. He received the Dr.Ing. degree in electronic engineering and the Ph.D. degree in metrology from Politecnico di Torino, Torino, Italy, in 1991 and 1995, respectively. Since 1995, he has been with Istituto Nazionale di Ricerca Metrologica (formerly Istituto Elettrotecnico Nazionale Galileo Ferraris), Torino, where he is involved in absolute cryogenic radiometry and quantum optics experiments. His research interests include low-noise and precision electronics.

Stefania Castelletto received her master degree in applied Physics Cum Laude in November 1992 from the University of Turin, and in 1998 she graduated with a PhD in Metrology at the Polytechnic of Turin. From 1998 she holds a position of a permanent researcher at INRIM. Her research interests are in precise optical measurement at the single photon level (single photon source and detectors) quantum information processing (quantum cryptography and communication), quantum and classical imaging. Her experience covers experimental quantum optics, parametric down-conversion based single photon sources, quantum and conventional radiometry in the visible, quantum and classical imaging.

Alan Migdall received his PhD in physics from MIT and BS in mathematics and physics from U. of Maryland. He is a member of the Optical Technology Division at NIST, where he is involved in projects that use two-photon light sources and their entanglement for absolute metrology and quantum information applications. He is also working on advancing single photon technology for these applications. Previous work included the laser cooling of atoms, which resulted in the first trapping of a neutral atom. As a means of encouraging single photon technology, Migdall has organized a number of workshops, symposiums, and special issues on the topic.