

CLOCK REQUIREMENTS AND TRADE-OFF FOR SATELLITE- BASED NAVIGATION SYSTEMS

E. Detoma¹, A. Godone², F. Levi², and P. Tavella²

¹ Alenia Spazio – Corso Marche, 41 - 10146 Torino, Italy

² Istituto Elettrotecnico Nazionale “G. Ferraris”
Strada delle Cacce, 91 - 10135, Torino, Italy

Abstract

Satellite-based navigation systems, such as GPS, Glonass, and the planned Galileo European system rely on stable atomic clocks for their operation. Space-borne and ground-based clocks provide the time frame allowing the users to perform passive ranging measurements and quickly locate their position [13].

From the operational point of view, timing stability enters the overall accuracy budget together with orbit estimation and operational constraints. User ranging accuracy is a complex function of many factors, and optimum selection of the clocks requirements is of paramount importance to optimize the overall system. Ideally, user range accuracy is affected by both timing and orbit estimation accuracy. In turn, both timing and orbit estimation are affected by the oscillator intrinsic accuracy and stability. Stability plays a role first in determining the optimum time interval over which the estimation is carried on and, secondly, in determining the maximum length of the time interval over which the computed estimates can be propagated and still be within the navigation system specifications.

Operational constraints, such as the maximum uploading rate for civilian systems, and the maximum unattended system operation vs. degraded performance for military systems, interact with purely technical considerations to define the “best” clock for a given application. To all this, we should add the requirements placed on the ground clocks which play a significant role in determining the overall system performance especially in systems (such as GPS or the planned Galileo) relying on the one-way passive ranging technique for orbit and clocks maintenance.

In the paper, we will discuss the requirements forced on the clocks by the specific application, as well as the consequent tradeoff dictated by the stability of the orbit and operational constraints. The clock constraints dictated by the simultaneous requirement to produce and disseminate timing information related to UTC (or TAI) will not be discussed, as we will limit our discussion to the aspects related to the navigation services only. In this frame, we would like also to present the rationale for the engineering development of a novel frequency standard (a Rb passive maser) being developed by the IEN and Alenia Spazio under an ASI (Agenzia Spaziale Italiana) contract specifically for possible applications in future navigation systems.

The opinions expressed in the papers are of the authors and do not imply necessarily the endorsement of the respective organizations.

Report Documentation Page

*Form Approved
OMB No. 0704-0188*

Public reporting burden for the collection of information is estimated to average 1 hour per response, including the time for reviewing instructions, searching existing data sources, gathering and maintaining the data needed, and completing and reviewing the collection of information. Send comments regarding this burden estimate or any other aspect of this collection of information, including suggestions for reducing this burden, to Washington Headquarters Services, Directorate for Information Operations and Reports, 1215 Jefferson Davis Highway, Suite 1204, Arlington VA 22202-4302. Respondents should be aware that notwithstanding any other provision of law, no person shall be subject to a penalty for failing to comply with a collection of information if it does not display a currently valid OMB control number.

1. REPORT DATE NOV 2001	2. REPORT TYPE	3. DATES COVERED 00-00-2001 to 00-00-2001			
4. TITLE AND SUBTITLE Clock Requirements and Trade-Off for Satellite-Based Navigation Systems		5a. CONTRACT NUMBER			
		5b. GRANT NUMBER			
		5c. PROGRAM ELEMENT NUMBER			
6. AUTHOR(S)		5d. PROJECT NUMBER			
		5e. TASK NUMBER			
		5f. WORK UNIT NUMBER			
7. PERFORMING ORGANIZATION NAME(S) AND ADDRESS(ES) Alenia Spazio - Corso Marche,41 - 10146 Torino, Italy,		8. PERFORMING ORGANIZATION REPORT NUMBER			
9. SPONSORING/MONITORING AGENCY NAME(S) AND ADDRESS(ES)		10. SPONSOR/MONITOR'S ACRONYM(S)			
		11. SPONSOR/MONITOR'S REPORT NUMBER(S)			
12. DISTRIBUTION/AVAILABILITY STATEMENT Approved for public release; distribution unlimited					
13. SUPPLEMENTARY NOTES See also ADM001482. 33rd Annual Precise Time and Time Interval (PTTI) Systems and Applications Meeting, 27-29 Nov 2001, Long Beach, CA					
14. ABSTRACT see report					
15. SUBJECT TERMS					
16. SECURITY CLASSIFICATION OF:			17. LIMITATION OF ABSTRACT Same as Report (SAR)	18. NUMBER OF PAGES 13	19a. NAME OF RESPONSIBLE PERSON
a. REPORT unclassified	b. ABSTRACT unclassified	c. THIS PAGE unclassified			

SYSTEM MAINTENANCE

Satellite-based navigation systems use one-way ranging measurements for system orbit estimation and time-keeping. The operational advantage of one-way ranging versus two-way ranging is obvious when one considers the complexity of the ground monitoring stations in the two approaches. One-way requires a simple omni-directional antenna to track all the satellites in view, is completely passive (non-transmitting) and the station can be deployed or re-deployed with minimum effort, requiring only a surveyed location, making it ideal for a military system. On the contrary, a two-way ranging station requires a complex transmitting equipment, a large directional antenna and, as a consequence, will not be able to simultaneously track multiple satellites, and it is expensive to deploy.

One-way ranging measurements are termed “pseudo-ranges,” since they contain the system clocks contributions, namely the space vehicle (SV) clock and the monitor station (MS) clock in addition to the propagation delay caused by finite propagation velocity v_p over the range:

$$(1) \quad \tilde{\rho} = v_p \cdot (\Delta t_{prop(SV-MS)} + \Delta t_{MS-SV}) = v_p \cdot [\Delta t_{prop(SV-MS)} + (\Delta t_{SV} + \Delta t_{MS})]$$

where in the last term we have expressed the contribution Δt_{MS-SV} to the pseudo-range measurement as the sum of the offsets of the individual clocks with respect to the system time which, for a composite clock solution¹, must satisfy, in principle, the relationship:

$$(2) \quad \sum_i w_i \cdot \Delta t_{SV,i} + \sum_j w_j \cdot \Delta t_{MS,j} = 0$$

and the sums are carried on over all SVs and MSs clocks in the system, each properly weighted with weights w_i and w_j .

The fundamental assumption of the one-way ranging technique is the capability to separate the three contributions to the pseudorange measurements, given a sufficient number of measurements. This will yield range observables, used to update the estimate of the orbit, and time offsets observables, to estimate the clock offsets and derive from the latter the clock parameters (phase and frequency offsets and drift) subject to condition (2).

However, a sufficient number of *independent measurements* are required to solve the system unknowns, but additional constraints apply for the term separation to be effective, namely that a sufficient number of *simultaneous independent measurements* be available. Simultaneity of observations from the same monitor stations of a large number of satellites, as well as simultaneous visibility of multiple stations by an individual satellite, is the key to an effective separation in the solution of the clock contributions from the pseudo-ranges.

Single and double-differencing techniques, widely used for data reduction in the geodetic community, will be of help in understanding the underlying physical rationale. When two satellites are simultaneously observed by a single monitor station (Figure 1), the first difference of the two pseudoranges drops the common MS clock term from the observable.

¹ If a Master Clock solution is chosen, all time offsets will be referenced to this single clock (or ensemble).

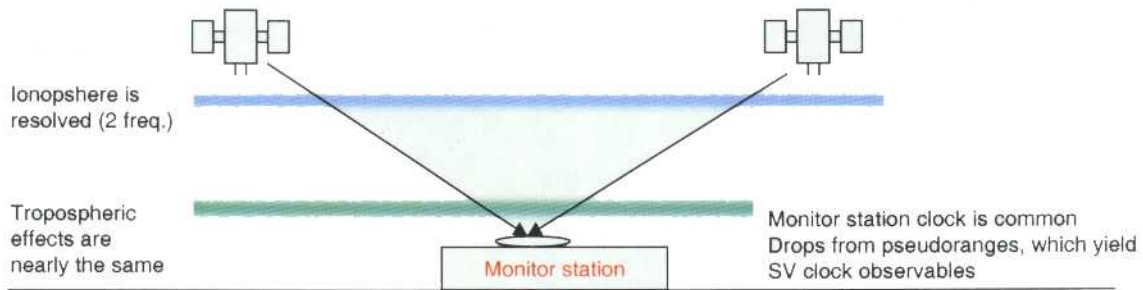

Figure 1 – Simultaneous observations from a single monitor station

Notice that we assume that the ionospheric propagation effects are completely removed by the use of the dual-frequency technique and tropospheric effects are common to the two measurements², so they cancel out too. This yields a nice observable for the SV clocks. When a single satellite is simultaneous in view of two ground stations, the situation depicted in Figure 2 applies.

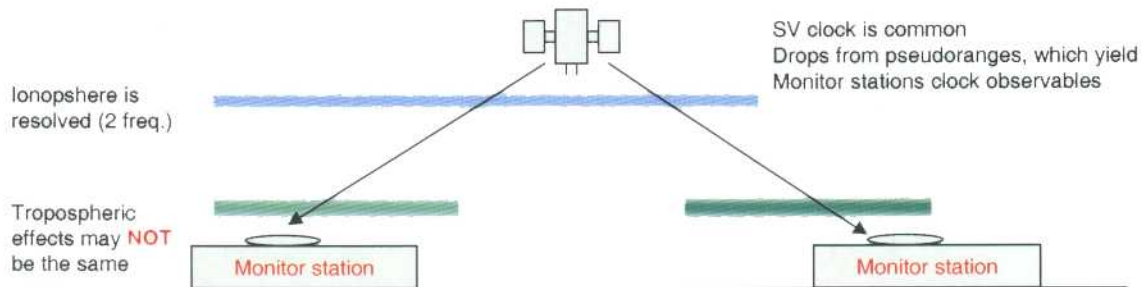

Figure 2 – Single satellite in simultaneous view of two monitor stations

Again, the first difference drops the SV clock and yields an observable which contains only the MS clock's contribution. However, while the same considerations for the ionospheric propagation still applies as before, now the tropospheric delay is not "common mode" and will affect the final estimation of the range and MS clock estimation.

Monitor stations clocks estimation (prediction) is affected by "local" propagation delays which are not correlated. Hence, errors propagate to orbit determination and indirectly affect the final user positioning/timing accuracy.

Since a second difference of a number of simultaneous observations having in common the SVs and the MSs will yield the orbit estimation free of clock terms, it is intuitive that the tropospheric effects are the

² This may not be always the case, since local perturbations to the atmospheric component of water vapor and temperature along the line of sight tend to be unequal when looking in different directions. In this respect, there are contrasting opinions on the requirements for additional measurements along the line of sight or concerning the magnitude of the effect with respect to modeling; but certainly the change in the index of refraction of the troposphere can be major when considering geographically separated sites.

major source of error left in the MS clocks state estimate and, as a consequence, of the MS clock states error projection on the orbit estimate.

Therefore, use and improvement of meteorological data and tropospheric propagation models is of importance in the overall system error budget. In parallel, an independent monitoring capability of the MS clock behavior (by two-way time transfer, for instance, as it has been proposed in several occasions in the past [14]) may help in highlighting possible mismodeling effects in the troposphere, as well as improving the capability to verify³ the MS clock's state estimate and its final contribution toward the orbit estimation errors⁴.

Looking at the overall system data flow, some considerations are readily apparent (Figure 3): measurements errors (pseudoranges) contains SV and MS clocks terms, as well as range (orbit-dependent) terms. The measurement errors are mainly radial and the OD&TS⁵ process projects these errors into the various components of the system state vector to yield estimates of SV clocks, MS clocks, and orbit elements, all of which are affected by the projections on the various states of the essentially radial measurement errors.

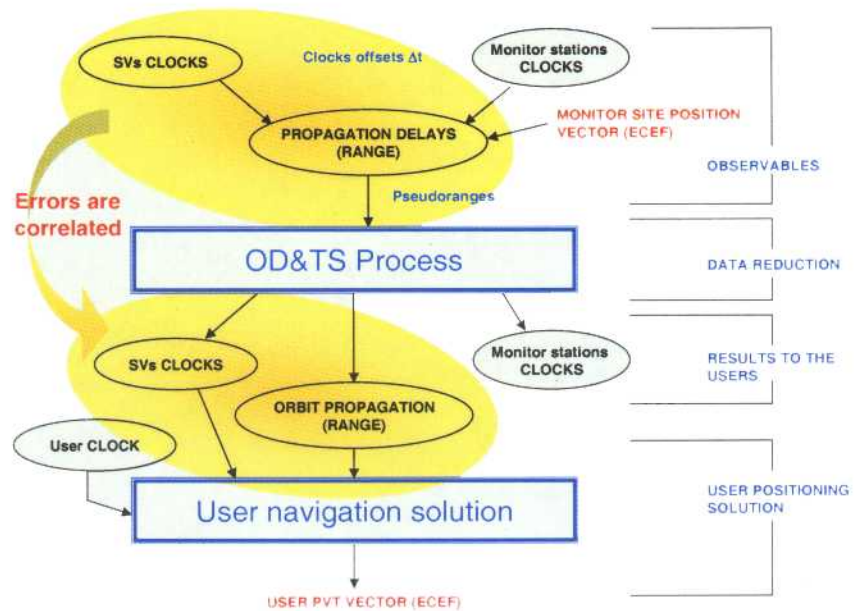

Figure 3 - Overall navigation system data flow

The navigation solution in the user set recombines SV clocks and range estimates based on system state prediction, where all errors recombine again in the radial direction. Since the user clock behavior can be neglected when solving for the PVT (position, velocity, and time) user vector, the strong correlation of SV and orbit estimation errors in the radial direction is beneficial for the user. However, MS state estimate

³ As an experimental device, a very useful technique involves the use of LASER ranging to a retroreflector array placed on the satellite. Besides the obvious result of verification of the ranging measurements, it is to be recalled that the troposphere is a dispersive medium at optical frequencies, so that a two-color ranging system may yield information about the troposphere refraction properties. The resulting data can be utilized also to correct the radio frequency measurements along the line-of-sight to the SV. The final addition of a two-color LASSO-type detector onboard, which is adding very little in terms of additional weight and power consumption, will allow the full separation of all the relevant terms involved in Eq. (1) with higher accuracy than available from the current operational measurement techniques.

⁴ As a possible alternative, two-way data may contribute to the frequency offset and drift estimation of the MS clocks, leaving the time offset determination to the ODT&TS function alone (to satisfy Eqs. (1) and (2) simultaneously).

⁵ OD&TS – Orbit Determination and Time Synchronization function.

errors do not enter the user solution; therefore, their effect on the estimation of the SVs clocks and orbit will affect the final user prediction embedded in the PVT solution.

The previous considerations lead to the use of stable oscillators in the ground monitor stations, where stability is to be emphasized in the double areas of:

- short- to medium-term stability, not to degrade the measurements over the time period used for orbit updating, as well as
- long-term stability to allow a clean separation of the clocks states, with the aim of improving the navigation system time stability and, overall, its orbital estimation accuracy.

ORBIT MAINTENANCE

To maintain the navigation accuracy of the system, orbit and time parameters need to be periodically updated, since both tend to drift with time and to increase the related errors. The periodical maintenance is based on frequent updates of the navigation parameters and less frequent tuning of system parameters or hardware calibration or replacement.

To insure that system accuracy will stay within the requirements⁶, the updates of the navigation parameters (orbit elements and clocks) must occur within the allowed limits of the degradation of the parameters themselves. These, in turn, are related to the intrinsic orbit stability (this takes into account gravitational field asymmetries, luni-solar perturbations, planetary perturbations, solar pressure effects, etc.) and to the clock stability. An example of orbit and clock degradation as they appear to the user is shown in Table 1 and in Figure 6 (from [4]). Since the overall accuracy is the sum of these two causes of degradation (orbit perturbations plus clock stability), a stable clock will help to maximize the update period for a given requirement. During each update interval, measurements are collected to generate a new set of parameters to be uploaded at the end of the data collection and processing sequence. The parameters degradation rate allows the setting of a maximum allowable update time interval between updates. Two approaches can be selected.

To maintain the navigation accuracy of the system, orbit and time parameters need to be periodically updated, since both tend to drift with time and to increase the related errors. The periodical maintenance is based on frequent updates of the navigation parameters and less frequent tuning of system parameters or hardware calibration or replacement.

In principle, as far as the clocks are concerned, the basic and simpler approach will be to select an update time interval such that the clock contribution to the total system error will be within specified limits and, therefore, negligible. This approach has the advantage that modeling of the clock is not necessary. Enough measurements are taken during each measurement interval (less or equal to the interval between updates) to solve completely for the orbit parameters and clock offsets. The latter are considered constant over the measurement and prediction intervals, since the clock stability guarantees that the contribution of the clock drift and instability will be negligible (only the frequency offset needs to be estimated).

⁶ Requirements here and in the following are intended for the “normal” operation of the system; survivability considerations when normal operations are disrupted will pose additional burdens on clocks long-term stability, but the relevant considerations are limited to military systems in particular phases of their operational life.

Error-- m	3-Hr AoD
Clock Prediction: (RMS over AoD)	
Filter estimate (Ao)	0.6
Freq Std Instability	0.44 (spec), 0.35 (Cs), 0.15 (Rb)
A1, A2 errors propagated	0.05
Ephemeris Prediction: (RMS over AoD)	
Filter estimate: Radial	0.5
Horizontal	1.8
Propagation: Radial	0.1
Horizontal	1.4
Total System	0.78 (Rb) to 0.95 (Spec)

Table 1 - Projected Block IIF Performance in Crosslink Navigation Update Mode (Age of Data of 3 hours); from [4].

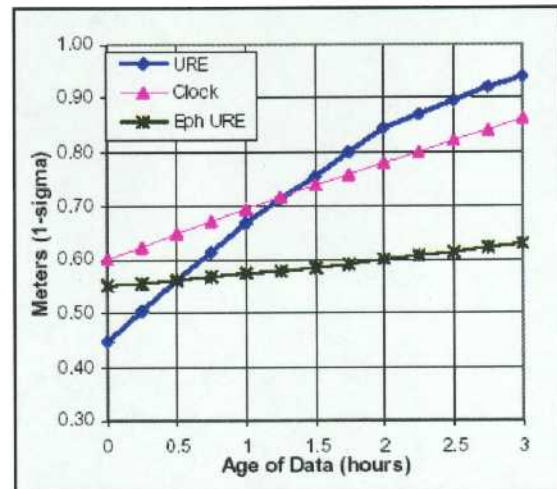

Figure 4 - Predicted Block IIF PPS URE vs. Age of Data in Crosslink Navigation Update Mode [4]

The possible drawback of this method follows from the consideration that measurements taken in successive update intervals are independent except for the orbit, which is propagated. Therefore, residual errors may accumulate in the clocks terms without bounds. This may result in a long-term orbit prediction which is very uniform but not very accurate, since any drift in the orbital parameters may simply accumulate in the clock terms, which are considered independent from one measurement period to the successive one.

Given the fact that atomic clocks are quite stable [5] and their behavior can be predicted over long time spans, the observations during one measurement period may be complemented by the prediction of the clock behavior over the past. The result is that the overall system errors are now bound by the clock stability over long time intervals, observations are supplemented by predictions which add additional information and help to detect clock malfunctions in the system. The maintenance operation now reverts to a classic predictor-corrector process, where the prediction is provided to the users for navigation purposes, but is also used by the system for the correction of the orbit and clock parameters. In the new situation, the clock estimates must be extended beyond the update interval, where the clock contribution to the total error was considered negligible. Then, a careful modeling of the clock(s) behavior is mandatory, to bound the errors to the measurements uncertainties alone and not to introduce additional errors due to the modeling and estimation process. Luckily, the systematic and stochastic behavior of stable oscillators has been intensively studied in the past 40 years, so current models are at least as good as the clocks themselves.

CLOCK ERROR MODEL

A good clock error model is of paramount importance in the design and operational maintenance phases of a satellite-based navigation system. For our purposes, a clock is a numerical integrator of the periodic signal produced by a stable oscillator; therefore, the timekeeping function is implemented by counting cycles, i.e., by numerically integrating the output frequency of the oscillator.

Frequency accuracy is of paramount importance for an accurate clock, while stability insures that accuracy is maintained over time, thereby insuring the uniformity and reproducibility of the time scale.

Stable atomic clocks are affected by systematic and stochastic errors that must be accurately modeled and characterized to insure optimum performance in the use of the device [1]. Generally, the basic model for a stable clock includes three parameters:

- 1) an initial time offset, $a_0 = \Delta t(t_0)$, which represents the inaccuracy in the setting of the initial time at t_0 ;
- 2) an initial frequency offset, a_1 , which represents the inaccuracy in setting the frequency of the clock at the time t_0 ; this parameter is customarily represented as normalized with respect to the nominal frequency of the oscillator f_0 , and in this case it is referred to as the initial fractional frequency offset of the oscillator, $\Delta f(t_0)/f_0$;
- 3) a frequency drift a_2 (a parameter referred to as ageing in crystal oscillators), which represents the change in time of the frequency offset. This parameter is generally assumed constant (or slowly varying with time) for all practical purposes.

Considering the clock as a numerical integrator, the above three terms can be regarded as the integration constants for the cascaded integrations that made up the oscillators and the clock: these are schematically shown in Figure 5.

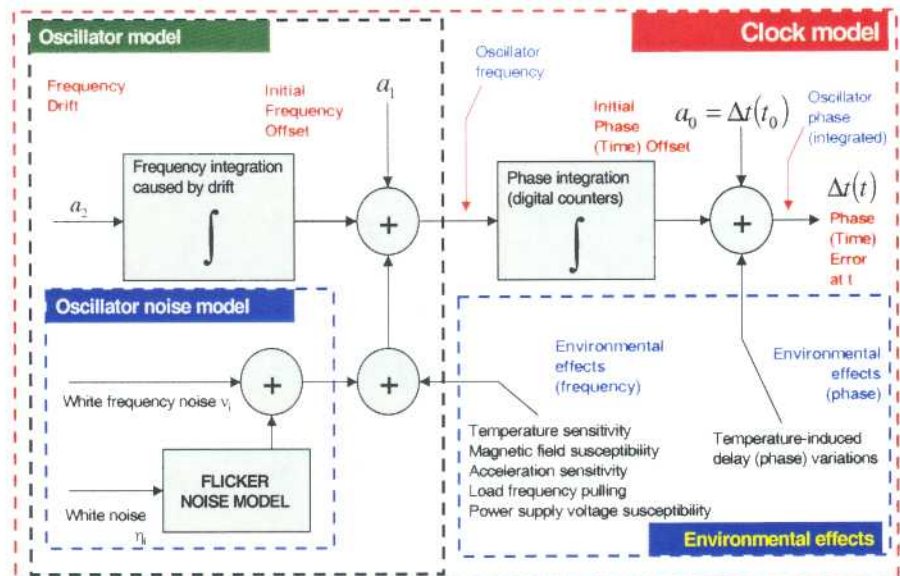

Figure 5 - Clock systematics model, including environmental and random effects

Here we have separated the oscillator model and the clock model, each with its own integrators. The accumulated time error $\Delta t(t)$ at the time t is a function of the above parameters and the integration functions, and can be expressed by the well-known formula:

$$(3) \quad \Delta t(t) = a_0 + \int_{t_0}^t a_1 + \int_{t_0}^t \left(\int_{t_0}^{t'} a_2 \cdot dt' \right) \cdot dt'' = a_0 + a_1 \cdot (t - t_0) + \frac{1}{2} \cdot a_2 \cdot (t - t_0)^2$$

This model, so far, includes only the systematic terms intrinsic to the oscillator and clock, but not external systematic effects that affect any additional departure from the nominal frequency and phase settings. These environmental effects affect the frequency of the oscillator, through temperature dependence,

acceleration, and magnetic field sensitivity, or voltage and load frequency pulling effects. Moreover, the clock integration may be affected too, for instance by delay changes in the electronics induced by temperature effects. Adding these additional environmental effects, the resulting model⁷ is graphically shown in the block diagram (Figure 5).

The noise processes affecting the output frequency of the oscillator dominate the stochastic behavior of the clock. These processes have been intensively studied during the past 40 years, and are characterized by a measurement of frequency instability expressed as spectral density of the phase noise (in the frequency domain) and Allan variance (in the time domain)[6]. Since for a clock we are usually interested in the time domain aspects of frequency instabilities, equation (3) is completed to account for stochastic effects as follows (including environmental effects):

$$(4) \quad \Delta t(t) = a_0 + a_1 \cdot (t - t_0) + \frac{1}{2} \cdot a_2 \cdot (t - t_0)^2 + \\ + \int_{t_0}^t [v(t') + \eta(t')] \cdot dt' + \sum_k \frac{\Delta f_k(p_k)}{f} \cdot (t - t_0) + \Delta t_{temp}$$

where the upper line in (4) accounts for the systematics, the first term of the second line accounts⁸ for the nonstationary noise processes of the oscillator⁹, the second term for the environmental effects affecting the frequency (the k parameters include temperature sensitivity, magnetic sensitivity, load-pulling effects, relativity, etc.), and the last term the delay (phase) fluctuations induced by temperature in the clock (counter's) electronics. More details on the clock model can be found in [3,6-10].

In practice, two steps are required to maintain a timing system when the data are acquired in batches and the clock state vector is estimated at regular intervals (as in the case of navigation systems):

1. *characterization* of the clocks behavior, i.e., estimation via measurements of the relevant parameters entering Eq. (4), namely:
 - time offset a_0 at some (initial) time t_0 – for all purposes; t_0 can be selected as completely arbitrary;
 - fractional frequency offset a_1 at t_0 ;
 - frequency drift a_2 , assuming that this term is constant to avoid a further integration in the model¹⁰;
 - frequency stability, expressed as the Allan variance $\sigma_y^2(\tau)$ over the time interval of interest (in this case the time required to carry on the measurements used to characterize the device)
 - sensitivity parameters p_k of the clock to the various environmental factors.
2. *prediction* of the clock behavior, i.e. forecasting of the clock error $\overline{\Delta t}(t)$ in time over some time

⁷ We have not considered random-walk noise processes, since they generally affect the oscillator at longer integration times than those considered for updating in the normal operations of a navigation system. These can be added to the model if required for simulation purposes.

⁸ This is not a very precise model of the time deviation of the clock due to the frequency stability effects, and better predictors can be used when the various noise processes contributions are taken into account separately.

⁹ $v(\tau)$ and $\eta(\tau)$ are the contributions due to the white frequency and flicker frequency noise processes respectively.

¹⁰ One-way pseudorange measurements may be supplemented by two-way data for the estimation of a_1 (and a_2 when needed) for the MS clocks – see note 4 above.

interval in the future, based again on the clock model expressed by (4), where now the relevant parameters are based on the estimate (1) above.

By considering that the stochastic components are given by gaussian noise with zero average, the prediction of the clock error $\overline{\Delta t}(t)$ comes straightforward from Eq. (4) above. The uncertainty of the prediction has to take into account the uncertainty in the estimation of the systematic parameters, as well as the possible covariances between estimates, and also the fact that the estimation of the stochastic components is influenced and influences the estimation of the systematic elements. The optimal estimation of these components is at the core of the current debate [9,10]. Let's concentrate at the moment only on the prediction of the stochastic components. The most common clock noises are gaussian and the uncertainty in the clock error $\overline{\Delta t}(t)$ prediction may be related to the Allan deviation by appropriate relationships [6,7,8]. In case of white and flicker FM, for example, the uncertainty of the $\overline{\Delta t}(t)$, here named $u_{\Delta t(t)}$, by assuming $t_0=0$, may be written as:

$$(5) \quad u_{\Delta t(t)} = \sigma_y^{WFM}(t) \cdot t + \frac{\sigma_y^{FFM}(t)}{\sqrt{\ln 2}} \cdot t$$

where $\sigma_y^{WFM}(t)$ stands for the Allan deviation of the white FM at time t , while $\sigma_y^{FFM}(t)$ stands for the flicker FM. The use of these relationships will help in the following section, where the prediction uncertainty of different clocks and the synchronization update rate will be discussed.

The estimation and prediction phases will generally overlap, since the clock error is propagated during the acquisition of the batch of measurements required to characterize the clock and enable the time error estimation over the next prediction interval. At the epoch in which a new estimate is generated, the clock error at the same epoch can be compared with the clock error previously estimated and the inaccuracy of the characterization/prediction process can be assessed, to validate both the measurement process and the state model.

Estimation/prediction methods generally fall in three main classes:

1. ARMA (Auto-Regressive Moving Average) /ARIMA (Auto-Regressive Integrated Moving Average) methods [2]
2. (Fixed) filters methods, based on some kind of functional fitting, generally polynomial [2,12]
3. (Adaptive) filters methods, based on Kalman filters.

Irrespective of the method, the process requires a data collection interval, where measurements are collected as a time-ordered series, to generate a set of prediction parameters that constitute the system state description over the next prediction interval.

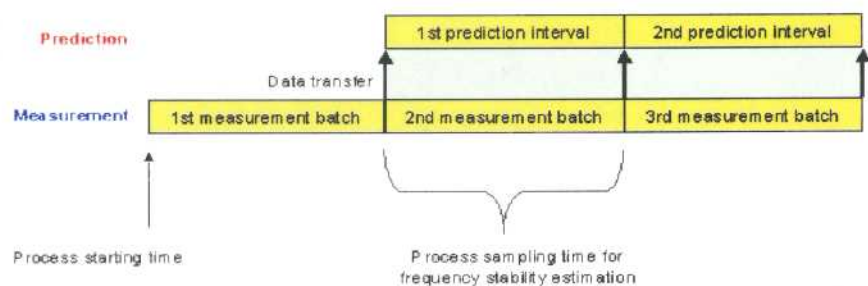

The frequency stability of the oscillator plays a key role not only in the prediction of the clock behavior, but also in the estimation of the systematic parameters at the end of each measurement interval. As a matter of fact, the frequency stability limits the estimation of the systematic parameters of the clock, and

the result is that the predicted $\overline{\Delta t} \neq 0$ at the beginning of the prediction interval. Since the aim is to minimize $\overline{\Delta t}$ at the end of the prediction interval, when a new batch of data has been acquired and a new clock state estimates is available, two constraints should be met to minimize $\overline{\Delta t}$:

- the length of the measurements/prediction periods should be made as short as possible, taking into account all operational constraints, since during the prediction the error increases with time
- the length of the measurements/prediction periods should be made long enough to allow the estimation of the clock parameters with sufficient accuracy.

NEW OSCILLATORS

Clearly, a tradeoff of the above conditions will highlight the necessity to reach the flicker frequency floor of the oscillator as soon as possible, to allow a precise characterization of the clock systematic parameters in the shortest possible time, again assuming that operational constraints will not pose further limitations.

Further, for shorter measurement/prediction intervals, the clock model can be simplified by dropping terms that have negligible effects over the measurement/prediction interval.

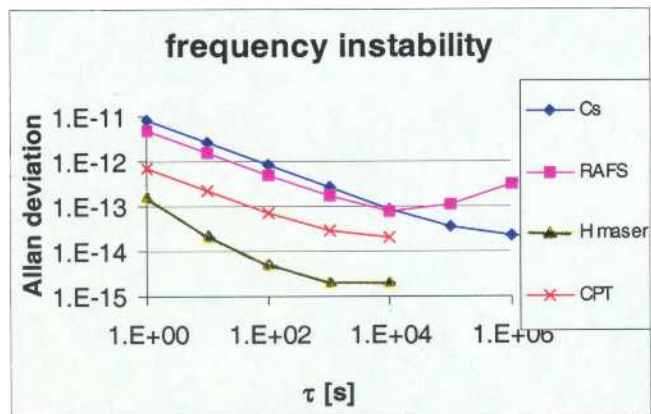

Figure 6 - Frequency instability for various atomic oscillators, including the proposed CPT Rb maser

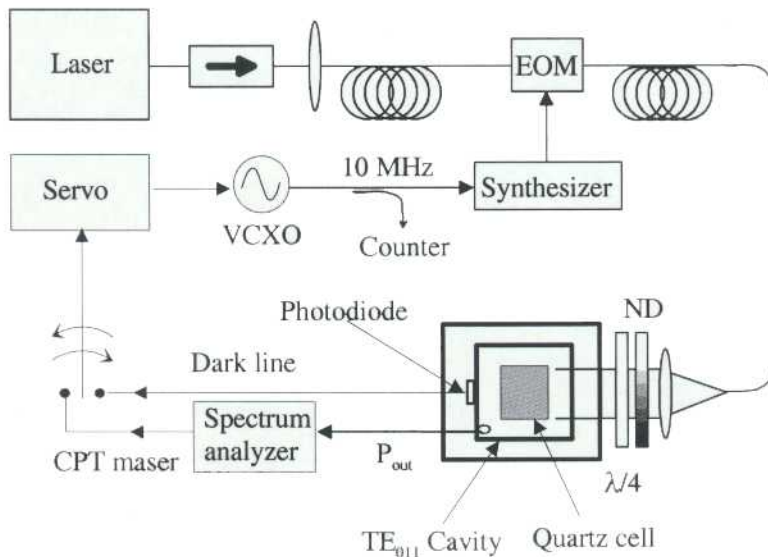

Figure 7 - Rb CPT experimental setup

However, the possibility that, for whatever operational reason, the prediction interval may be extended during contingency situations, may require careful considerations in the definition of a simplified model (and also in the choice of oscillators with no performance margin).

H-masers, both of the active and passive types, are characterized by an exceptional short- to medium-term frequency stability, and are considered in the baseline for spaceborne oscillators in new systems, like Galileo (Figure 6).

However, they are complex devices and require vacuum pumps and hydrogen reservoirs that may limit long-term reliability, even if outstanding results have been presented in recent times. An interesting device has been recently proposed: the coherent population trapping (CPT) maser [11]. To maintain the navigation accuracy of the system, orbit and time parameters need to be periodically updated, since both tend to drift with time and to increase the related errors. The periodical maintenance is based on frequent updates of the navigation parameters and less frequent tuning of system parameters or hardware calibration or replacement. This oscillator is based on a low density vapor of Cs or Rb contained in a cell with buffer gas and coupled to a microwave cavity tuned to the atomic ground state hyperfine frequency.

The atomic sample is excited by two laser fields that couple the two ground state hyperfine levels to the excited $P_{1/2}$ or $P_{3/2}$ states.

This Λ scheme excitation process leads to the presence of a dark line in the fluorescence spectrum and to an oscillating magnetization responsible for a coherent microwave emission at the hyperfine frequency. Both signals may be used as atomic reference as shown in the experimental setup shown in Figure 7. The laser carrier is phase-modulated by an electro-optic modulator and the two first sidebands provide the radiation fields required for the excitation of the atomic ensemble.

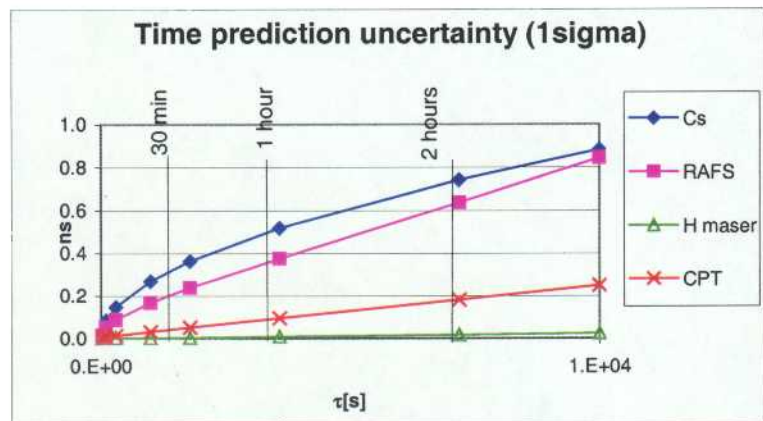

Figure 8 - Time prediction uncertainty for various atomic oscillators, including the proposed CPT Rb maser.

The high degree of symmetry of this excitation scheme strongly reduces the light-shift effect that is considered the main source of frequency instability for the optically pumped passive standards in the short-to-medium term.

Moreover, the microwave signal is observed without any background and allows a strong reduction of the laser amplitude fluctuations transferred on the output signal. The timing performance of this device, resulting from the projected frequency stability (Figure 6), stand midway between the classic optically pumped Rb passive cell and the passive H-maser, providing a reasonable option for future spaceborne clocks.

REFERENCES

- [1] G. L. Mealy and D. R. Van der Stoep, 1975, "Time standard error modeling with applications to satellite navigation," in Proceedings of the 29th Annual Symposium on Frequency Control, 28-30 May 1975, Fort Monmouth, New Jersey, USA, pp. 417-424.

- [2] D. B. Percival, 1977, "*Prediction error analysis of atomic frequency standards,*" in Proceedings of the 31st Annual Symposium on Frequency Control, 1-3 June 1977, Fort Monmouth, New Jersey, USA, pp. 319-326.
- [3] A. Albanese, G. Graglia, and P. Tavella, 2001, "*Clock error modeling and frequency prediction in the Galileo GNSS2 System,*" in Proceedings of the 2001 GNSS Symposium, 8-11 May 2001, Seville, Spain.
- [4] K. Ghassemi and S.C. Fisher, 1997, "*Performance Projections of GPS II,*" in Proceedings of the 10th International Technical Meeting of the Satellite Division of the Institute of Navigation, ION GPS 1997 Meeting, 16-19 September 1997, Kansas City, Missouri, USA, pp. 407-415.
- [5] P. Rochat and F. Droz, 2001, "*Presentation on Rb oscillators development for Galileo,*" ESA 2001 Workshop on European Clocks for Galileo, 4 September 2001, Noordwijk, the Netherlands.
- [6] D. W. Allan, 1987, "*Time and Frequency (Time-Domain) Characterization, Estimation and Prediction of Precise Clocks and Oscillators,*" **IEEE Transactions on Ultrasonics, Ferroelectrics, and Frequency Control**, UFFC-34, 647-654.
- [7] J. W. Chaffee, 1987, "*Relating the Allan Variance to the Diffusion Coefficients of a Linear Stochastic Differential Equation Model for Precision Oscillators,*" **IEEE Transactions on Ultrasonics, Ferroelectrics, and Frequency Control**, UFFC-34, 655-658.
- [8] P. Tavella and M. Gotta, 2000, "*Uncertainty and prediction of clock errors in space and ground applications,*" in Proceedings of the 14th European Frequency and Time Forum (EFTF), 14-16 March 2000, Torino, Italy, pp. 77-81.
- [9] J. Delporte, et al., 2001, "*Modelisation and extrapolation of time deviation: application to the estimation of the datation stability of a navigation payload,*" in Proceedings of the 15th European Frequency and Time (EFTF) Forum, 6-8 March 2001, Neuchâtel, Switzerland, pp. 123-128.
- [10] G. Busca, 2001, "*Impact of clock behavior on SISA,*" ESA 2001 Workshop on European Clocks for Galileo, 4 September 2001, Noordwijk, the Netherlands.
- [11] A. Godone, F. Levi, S. Micalizio, and J. Vanier, 2001, "*The coherent population trapping maser,*" in Proceedings of the 6th Symposium on Frequency Standards and Metrology, 9-14 September 2001, St. Andrews, Scotland.
- [12] E. Detoma, A. Clinton, W. Hanrahan, P. Kushmeider, R. Price, and P. Dachel, 1988, "*Timing data reduction and processing for the NASA Goddard Laser Tracking Network (GLTN),*" in Proceedings of the 2nd European Frequency and Time Forum (EFTF), 16-18 March 1988, Neuchâtel, Switzerland, pp. 275-292.
- [13] A. J. Van Dierendonck and M. Birnbaum, 1976, "*Time Requirements in the Navstar Global Positioning System (GPS),*" in Proceedings of the 30th Annual Symposium on Frequency Control, 2-4 June 1976, Fort Monmouth, New Jersey, USA, pp. 375-383.

- [14] I. J. Galysh, D.M. Craig, W.G. Reid, and J. Buisson, 1996, "*Performance analysis of the GPS monitor station timing subsystem enhancement program at the Naval Research Laboratory,*" in Proceedings of the 28th Annual Precise Time and Time Interval (PTTI) Applications and Planning Meeting, 3-5 December 1996, Reston, Virginia, USA (U.S. Naval Observatory, Washington, DC), pp. 417-428.