

# Micro-Air Vehicle (MAV) - Demonstrated Backpackable Autonomous VTOL UAV Providing Hover and Stare RSTA to the Small Military Unit

Mr. Daniel Newman  
Program Manager  
Defense Advanced Research Projects Agency  
Tactical Technology Office  
Arlington, Virginia 22003

## ABSTRACT

The objective of the Micro Air Vehicle (MAV) Advanced Concept Technology Demonstration (ACTD) is to demonstrate an affordable, responsive, easy-to-operate, backpackable reconnaissance and surveillance system. The MAV system provides the small unit with militarily useful real-time combat information about difficult-to-observe or distant areas and objects in urban and complex terrain.

The paper will review the MAV program, outline several of the ongoing studies of other military applications of MAV, and provide a description of the ongoing Military Utility Assessment (MUA) being conducted by the U.S. Army.

## 1. INTRODUCTION

The Defense Advanced Research Projects Agency (DARPA) MAV program is an ACTD that is working to determine the value of backpackable ducted fan unmanned aerial vehicles employed at the small infantry unit level. The ACTD is a program jointly sponsored and managed by DARPA, United States Pacific Command, the U.S. Army and the office of the Deputy Under Secretary of Defense for Advanced Systems and Concepts. The specific military unit involved in the development and testing of this prototype system is the 25th Infantry Division as part of the United States Army Pacific (USARPAC). The products of the MAV ACTD are a military utility assessment (MUA) and residual unmanned aerial vehicle (UAV) systems that will remain with the 25th Infantry Division (ID) for extended user evaluations over a two year period. MAV ducted fan technology has already transitioned to the U.S. Army Future Combat System (FCS) program. The MAV is the basis for the FCS Class 1 vehicle which is now in the System Development and Demonstration (SDD) phase.

### 1.1 Program Motivation

DARPA's technical focus on development and experimentation with the micro air vehicles was to validate the effectiveness of ducted fan small UAVs for use with small military units. Small fixed wing UAVs

have now proliferated within the U.S. military. While time-on-station performance will always favor a fixed-wing air vehicles, small UAVs capable of vertical take off and landing fill a critical need to provide a highly controllable persistent sensor orientation and field of regard for military areas of interest.

Small ducted fan systems offer a safe vertical takeoff and landing (VTOL) UAV solution with the ability to hover in very close proximity to buildings, which may be very useful in urban combat. Figure 1 shows a depiction of MAV in urban operations. Soldier safety was a key driver for pursuing this technical approach in lieu of an open rotor approach.



*Figure 1: Artist Depiction of MAV in Urban Operations*

### 1.2 Program Description

The MAV ACTD has employed a two-phased spiral development approach to incrementally develop and demonstrate desired MAV capabilities. In FY04, the program conducted Phase 1 system requirements analysis and detailed design of an air vehicle with a COTS engine. One of the system requirements for the objective Phase II system was that use of a heavy fuel engine (HFE) capable of running on JP-8. Because a HFE did not exist in this size, a parallel HFE development effort was conducted in

# Report Documentation Page

*Form Approved  
OMB No. 0704-0188*

Public reporting burden for the collection of information is estimated to average 1 hour per response, including the time for reviewing instructions, searching existing data sources, gathering and maintaining the data needed, and completing and reviewing the collection of information. Send comments regarding this burden estimate or any other aspect of this collection of information, including suggestions for reducing this burden, to Washington Headquarters Services, Directorate for Information Operations and Reports, 1215 Jefferson Davis Highway, Suite 1204, Arlington VA 22202-4302. Respondents should be aware that notwithstanding any other provision of law, no person shall be subject to a penalty for failing to comply with a collection of information if it does not display a currently valid OMB control number.

1. REPORT DATE <b>01 NOV 2006</b>	2. REPORT TYPE <b>N/A</b>	3. DATES COVERED <b>-</b>	
4. TITLE AND SUBTITLE <b>Micro-Air Vehicle (MAV) - Demonstrated Backpackable Autonomous VTOL UAV Providing Hover and Stare RSTA to the Small Military Unit</b>		5a. CONTRACT NUMBER	
		5b. GRANT NUMBER	
		5c. PROGRAM ELEMENT NUMBER	
6. AUTHOR(S)		5d. PROJECT NUMBER	
		5e. TASK NUMBER	
		5f. WORK UNIT NUMBER	
7. PERFORMING ORGANIZATION NAME(S) AND ADDRESS(ES) <b>Defense Advanced Research Projects Agency Tactical Technology Office Arlington, Virginia 22003</b>		8. PERFORMING ORGANIZATION REPORT NUMBER	
9. SPONSORING/MONITORING AGENCY NAME(S) AND ADDRESS(ES)		10. SPONSOR/MONITOR'S ACRONYM(S)	
		11. SPONSOR/MONITOR'S REPORT NUMBER(S)	
12. DISTRIBUTION/AVAILABILITY STATEMENT <b>Approved for public release, distribution unlimited</b>			
13. SUPPLEMENTARY NOTES <b>See also ADM002075., The original document contains color images.</b>			
14. ABSTRACT			
15. SUBJECT TERMS			
16. SECURITY CLASSIFICATION OF:			17. LIMITATION OF ABSTRACT
a. REPORT <b>unclassified</b>	b. ABSTRACT <b>unclassified</b>	c. THIS PAGE <b>unclassified</b>	<b>UU</b>
			18. NUMBER OF PAGES <b>23</b>
			19a. NAME OF RESPONSIBLE PERSON

Phase I. The program plan called for integrating the HFE into the system in the second spiral in Phase II. In FY05, the program completed development of the Phase I vehicle and conducted field evaluations of the Phase I system. In FY06, the program integrated feedback from Phase 1 field evaluations into the Phase 2 MAV system. Because the HFE engines developed in Phase I were not yet mature enough for integration, the ACTD management team decided to continue HFE development while moving forward with a gasoline engine for the Phase II system. The Phase II activity culminates with 25 MAV systems undergoing a military utility assessment (MUA). After the MUA is complete, the residual systems will be used by the 25th ID for additional experimentation.

The MAV program recently completed government acceptance testing of the Phase II system. This was followed by a functional assessment of the system conducted by the U.S. Army Soldier Battle Lab and training of the platoon leader and noncommissioned officers (NCOs) from a Stryker scout platoon. Currently, these platoon leader and NCOs trained six soldiers from their platoon and are conducting an MUA at Schofield Barracks, Oahu, Hawaii.

To date over 500 successful flights have been conducted with the MAV. The vehicle has demonstrated the ability to fly up to 50 knots of forward flight, fly in rain, hover in winds up to 20 knots, fly at high density altitudes, fly at up to 500 feet AGL, execute 8 km single waypoint and multiple shorter waypoint segments, demonstrate day/night forward and down-looking video sensor imagery, sensor frame capture and storage, and close proximity flight with buildings.

### 3. MAV SYSTEM DESCRIPTION

The MAV system is a unique small UAV due to its ability to “hover and stare” in urban and complex environments. The vehicle operates from a stationary hover through forward flight at relatively low altitudes above ground level (AGLs). MAV typically flies within 100 feet to 500 feet AGL. It provides forward and down-looking video and still imagery under day or night (infrared) conditions. It also operates at density altitudes up to 11,000 feet where tactical military units typically operate. The vehicle can launch and operate in adverse weather conditions such as rain and wind.

A MAV system is currently defined as two air vehicles and the associated support equipment – fuel, batteries, observer/controller unit (OCU), fuel pump, vehicle starters (1 per vehicle) and carrying cases. The vehicles currently weigh around 18 pound. The vehicle weight is driven by the ~2 lb fuel load, the weight of the sensors and the requirement for adequate thrust/weight

ratio for robust control margin in adverse weather and high density altitude conditions.

#### 3.1 MAV Vehicle

The MAV vehicle is shown in Figure 2. The vehicle consists of a ducted fan center body and 2 removable side pods. The avionics pod (shown on the left) houses a battery, avionics card stack and navigation sensors. The sensor pod (shown on the right) houses communication radios, a GPS receiver, a forward looking imaging sensor and a down-looking imaging sensor. Two sensor pod configurations exist - one with two visible sensors and one with two infrared sensors.

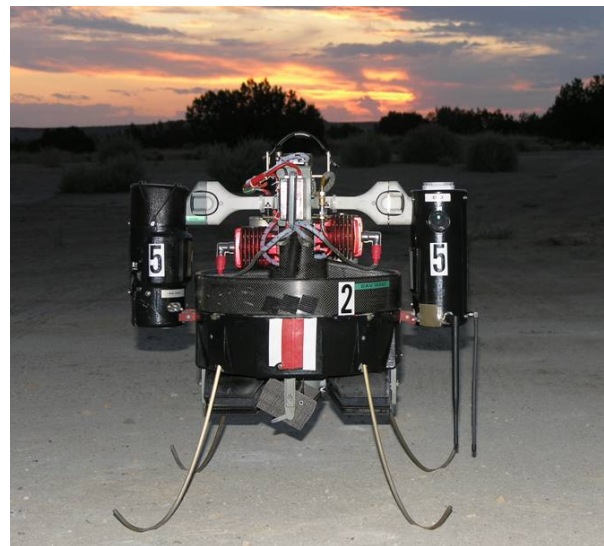

Figure 2. MAV Vehicle

The vehicle is powered by an off-the-shelf gasoline engine in the 4 horsepower class. It is controlled by means of an autonomous flight stabilization and control system that uses inputs from an inertial measurement unit and a global positioning system (GPS) receiver to formulate control surface commands. The control surfaces consist of four box control vanes that operate independently.

#### 3.2 MAV Ground Control Station

The Ground Control System (GCS) is shown in Figure 3. It consists of a rugged tablet PC known as the Operator Control Unit (OCU, shown at the bottom) and a Ground Data Terminal (GDT, green box at the top). The OCU uses a stylus for a point and click user interface. The GDT houses a GPS receiver, battery and communications radios and antennas. The GDT connects to the OCU through a USB port.



The OCU runs software for mission planning and high level control of the system. The system requires no piloting skills to operate. The MAV can be programmed with up to 100 waypoints for an autonomous flight plan. All waypoints are established directly at the ground control station through a simple touch screen interface. Up to 10 pre-planned flight plans can be stored on the ground station and can be dynamically loaded into the vehicle in flight. The flight planning software provides multiple pre-programmed loiter patterns which can be used in developing flight plans.



Figure 3. MAV Ground Control System

### 3.3 System Operation

The takeoff, landing and handling procedures and features for this vehicle were developed with soldier safety and support in mind. Once the landing legs are snapped on and the two side pods connected, the vehicle is put in place on the ground and started by a pull cord. A mission plan is uploaded to the vehicle from the GCS and executed. From then on, the vehicle can be completely “hands off” until the mission is completed and the engine has autonomously shut down. Fueling is currently done with a manual syringe pump and can be done day or night.

The MAV is designed to be fully autonomous from the take off command, and yet it is also capable of operator intervention to control the sensor fields of regards, or to allow in-flight mission reprogramming. The operators never actually “fly the vehicle” in the teleoperation sense. The vehicle is programmed to

execute a series of waypoints and/or flight pattern characteristics, with waypoint durations or holds included. After launch the OCU can be ignored with the exception of monitoring imagery or vehicle status. At any point during a mission the operator can suspend the flight plan and provide high level commands to effect the sensor orientation. The operator is able to manually direct the sensor in a particular direction (up, down, left, right, fore and aft, and clockwise or counterclockwise) and the vehicle responds to the sensor commands appropriately so that the soldier can observe the desired forward or down-looking sensor imagery in the OCU video display. At present, the OCU and system is capable of providing very accurate target coordinates as a result of its navigation system, sensor frame capture and sensor to vehicle integration. The system is also able to remotely start and launch with the vehicle geographically separate from the OCU, and then once the vehicle reaches a preset altitude, a soldier with the OCU in a different location can take over via uplink commands, upload a flight mission plan, and command the MAV to execute the desired mission.

Figure 4 shows soldier emplacing and preparing to launch the vehicle.



Figure 4. MAV Operation by Soldiers During Phase I Experimentation

The system operators currently require less than 24 total hours of training time and are then able to start flying the vehicle for proficiency development. No special military occupation specialty (MOS) is required to operate this system, as evidenced by 25th ID use of infantrymen and scouts in the conduct of experimentation. A critical assessment from the military to date is that no special additional military training is required for operation of the vehicle or exploitation of the data and imagery. Initial training and flights can be done at the military units "home station." MAV is a tool organic to the small military unit.

#### 4. EXPERIMENTATION AND DESIGN ITERATION

During October 2005, the Phase I MAVs were flown in military experimentation with a dismounted platoon from the 25th Infantry Division. Figure 5 shows the MAV in operation at the Schofield Barracks MOU site. The platoon conducted a series of instrumented missions with and without the MAVs in order to conduct initial assessment of military utility and to provide recommended modifications to the air vehicle and support systems as part of second and final phase of the program. Tactical missions such as route reconnaissance, area reconnaissance, convoy escort and assault an objective were done. The platoon and opposing force (OPFOR) provided assessments of the "value-added" or hindrance in executing the missions. Missions were repeated if possible in order to allow the OPFOR to evolve tactics and to allow the military platoon to improve their use of the MAV. Assessments were provided and documented and the units were instrumented with the Operational Test - Tactical Engagement System (OT-TES, a recent generation of MILES) in order to provide quantitative data of the units mission performance. The OPFOR clearly forced the unit to alter their traditional tactics – and in particular forced them to quickly abandon the "high ground" or any line-of-sight exposed position.

The military unit examined flight performance such as altitude, range, winds and takeoff and landing approaches. They examined the vehicle fueling approaches, the packing of the vehicles and systems, and techniques to share the carriage of unit equipment since they are required to backpack the vehicles as part of their dismounted missions. They assessed performance of down-looking and forward-looking sensors for day and night missions. In addition the platoon carefully evaluated the data links, the OCU and its graphical user interface (GUI), and the utility of the remote video terminal to provide intelligence and operational value. The platoon was invaluable in providing operational lessons-learned as well as information on the intelligence value of MAVs in preparation for infantry missions.



*Figure 5. MAV in operation at Schofield*

The initial Phase I assessment of the vehicle was very positive, and the unit provided a number of insightful recommendations for improvement, such as better starting approaches, needed navigation modifications, GUI modifications, the need for extra flight-time, and lessons in organizational staffing to support field operations. The platoon leader and noncommissioned officers also provided valuable insights into CONOPS (concepts of operation) development and how military leaders will and will not operate these vehicles in direct support of small military unit operations.

At the beginning of Phase II, numerous design improvements were implemented. The most significant of these are the doubling of fuel volume for a 2X improvement in endurance and replacement of all imaging sensors. These major design changes required a redesign of the center body structure. And sensor pod structures.

The Phase II experimentation is currently under way with the new vehicle design, and will result in a substantially greater number of vehicles delivered to the 25<sup>th</sup> ID. A rigorous evaluation of the MAV system is being performed over a 30 day period and will result in detailed a detailed MUA report in March of 2007.

The Phase II MUA exercises are being conducted by a scout platoon from a Stryker Brigade. Both dismounted and mounted operations are included in the MUA. Sample missions being conducted in the Phase II

exercises are: MOUT Recon and Clear a Building (dismounted), Route Recon, Area Recon, and a Screen.

## **5. OTHER MILITARY APPLICATIONS AND ENHANCEMENTS**

DARPA is currently performing studies on other military applications and system enhancements for MAV. These include use of MAV by the Navy for littoral and riverine operations; enhancement of MAV to allow ground moving target indicator (GMTI) sensor operations of a small area for improve situational awareness; and implementation of a common GCS to allow interoperability with other small UAVs such as Raven and Dragon Eye.





*25<sup>th</sup> Army Science Conference*  
*EO-05*

# Micro-Air Vehicle (MAV)

## Demonstrated Backpackable Autonomous VTOL UAV Providing Hover and Stare RSTA to the Small Military Unit



**Dan Newman**

**Tactical Technology Office  
Defense Advanced Research Projects Agency**

**30 November, 2006**

Approved for Public Release, Distribution Unlimited

Reference DARPA Cases 5805, 7030, 7778, 7970, 8131



# Micro Air Vehicle Topics



- **Small Units Needs in Current Conflicts**
- **UAVs Impact on Modern Military Operations**
- **Micro Air Vehicle (MAV)  
Advanced Concept Technology Demonstration (ACTD)**
- **MAV System**
- **MAV Operations**
- **Summary**

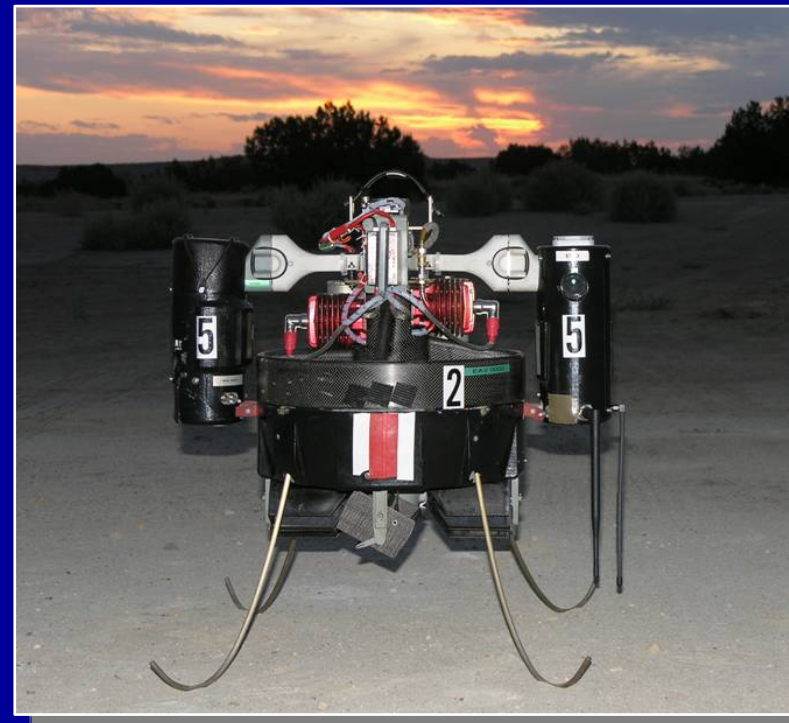





# Micro Air Vehicle

## Current Conflicts are Unconventional



- **Complex scenarios on modern battlefield**
- **Soldiers must execute Military Operations Other Than War (MOOTW)**
- **“Three Block War” concept** (*Gen. Charles Krulak*)  
*Across 3 contiguous city blocks may encounter*
  - *high-intensity combat*
  - *peacekeeping operations*
  - *humanitarian missions**often in dense urban settings*
- **Must ensure safety of non-combatants & friendly forces**
- **Very high fidelity situational awareness required**
- **Rules of engagement typically demand “eyes-on-target”**
- **Generally precludes beyond line-of-sight missions**





# Micro Air Vehicle

## UAVs Changing Modern Military Operations



- **Unmanned systems enable forward observer presence without placing soldiers at risk**
- **Limited support to small units from fielded UAVs**
  - Fixed-wing CTOL (Conventional Takeoff & Landing) Launch & Recovery
  - Organized/assigned far above small units
  - Significant technical support required
  - Sensor location / orientation constrained by minimum airspeed
  - Operations remote from complex terrain
- **Need to gather & transmit battlefield information in small unit operations**
- **DARPA Micro Air Vehicle (MAV): developed to demonstrate organic airborne RSTA to small combat units**

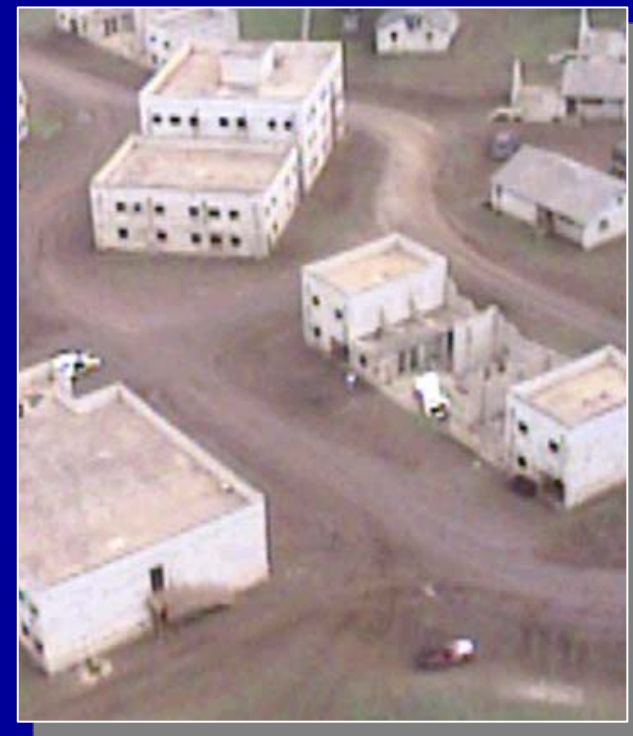



# Military Need



*Small military units need a reconnaissance and surveillance (R&S) system with the following capability:*

- **Hover and Stare**
- **Vertically launched and landed**
- **Operate in urban terrain and the mountains of Afghanistan**
  - **Between buildings**
  - **10,500 Ft**
- **Simple to learn and use**
- **Capable of autonomous take off, flight and landing**
- **Provide situational understanding and targeting information**
  - **ID man size targets**
    - **At distance of 250 meters daytime**
    - **At distance of 125 meters at night**
  - **Target location error of less than 80 meters**
- **Backpackable**





# Micro Air Vehicle

## Advanced Concept Technology Demonstration (ACTD)



### Objective:

*Demonstrate affordable, responsive, easy-to-operate, backpackable reconnaissance and surveillance system*

**OSD ACTD: Executive Agent - DARPA**

**ACTD User Sponsor: USPACOM**

- *USARPAC, G2/DCSINT as user representative*

### ACTD Managers

- **Technical Manager: DARPA**

*Program Management & delivery of MAV system*

- **Transition Manager: US Army PM-UAS**

*Transition of MAV system into current and/or future force*

- **Operational Manager: US Army Pacific Command, G2/DCSINT**

*Develop requirements, plan & execute experimentation, conduct Military Utility assessment*

### Key ACTD Participant: 25th Infantry Division

- *Operational expertise*
- *Operate MAV System*
- *CONOPS, TTP development*
- *Demonstration and Evaluation at Schofield Barracks, Military Utility Assessment*





# MAV ACTD

## Significant Development Milestones



- **Sep 2003**      **Launch Development under DARPA contract**
- **Nov 2003**      **Detailed Requirements Review**
- **Mar 2004**      **Preliminary Design Review**
- **Nov 2004**      **Critical Design Review**
- **Dec 2004**      **1st Tethered Flight**
- **Mar 2005**      **1st official off-tethered flight**
- **July 2005**      **Govt Acceptance Testing & Safety Release**
- **Aug 2005**      **Operational Tests, Fort Benning, GA**
- **Oct 2005**      **Operational Tests, Schofield Barracks, HI**
- *May 2006*      *Selected Future Combat Systems Class 1 UAV*
- *Sep 2006*      *EOD Award to Combat IED*
- **Oct 2006**      **Military Utility Assessment, Schofield Barracks, HI**
- **Mar 2007**      **MUA Report Released**



# Micro Air Vehicle System Description



- **Platoon-level RSTA, ISR/SA/day-night "hover & stare" capability**
- **Man-packable, Fully Autonomous Hover and Stare**
  - **Two air vehicles**
  - **Operator Control Unit**  
*(observer/controller and remote video)*
  - **Ground Data Terminal**
  - **Operating and Maintenance Equipment**  
*(fuel, batteries, starter)*
  - **MOLLE pack for transport**
- **Developed by Honeywell under DARPA contract**
- **Supports Army Future Combat Systems (FCS) Class 1 UAV (organic to platoon)**

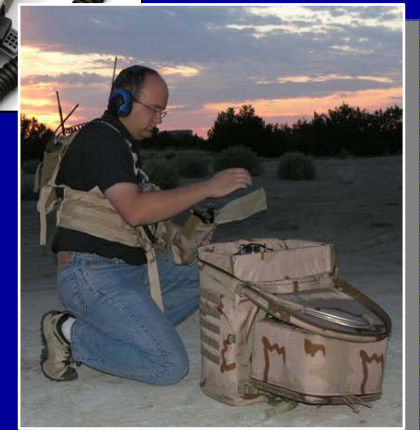
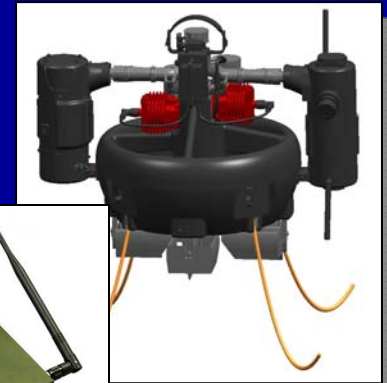





# Micro Air Vehicle

## Micro Air Vehicle



- **Vertical Take Off and Landing (VTOL)**

*simplifies launch & recovery, esp. in confined/complex terrain (mountain, jungle, urban)*

- **Ducted Fan Air Vehicle**

- **Enclosed fan protects from impact (trees, buildings)**
- **Quicker to deploy and safer to handle**

- **COTS gas engine** (*heavy fuel engine in development*)

- **Performance**

- *Service ceiling 10,500 feet*
- *Endurance > 44 minutes at 5,500 feet*
- *Climb rate of 24 feet/sec*
- *Airspeed 50 knots in favorable conditions*

- **Robust Operating Environment**

- *Capable of operation in rain, salt, fog, sand, dust*
- *Stable flight in 20 knot winds*
- *Take-off and land in 15 knot winds*
- *Temperature Range 0°F - 115°F, 100% humidity, 0.5 inch/hour rain*





# Micro Air Vehicle Payload/Sensor



- **Two Interchangeable Sensor Pods**
  - Infrared or Electro-optical with zoom
  - **Dual Sensors**
    - Forward Looking
    - Downward Looking
  - Sensor payloads
  - Communication
  - GPS
- **Real-time viewing at ground station & on-board recording (NLOS objectives)**
- **Accurately detects & recognizes man-sized targets ...**
  - at 250m distance with EO sensor
  - at 125m distance with IR sensor

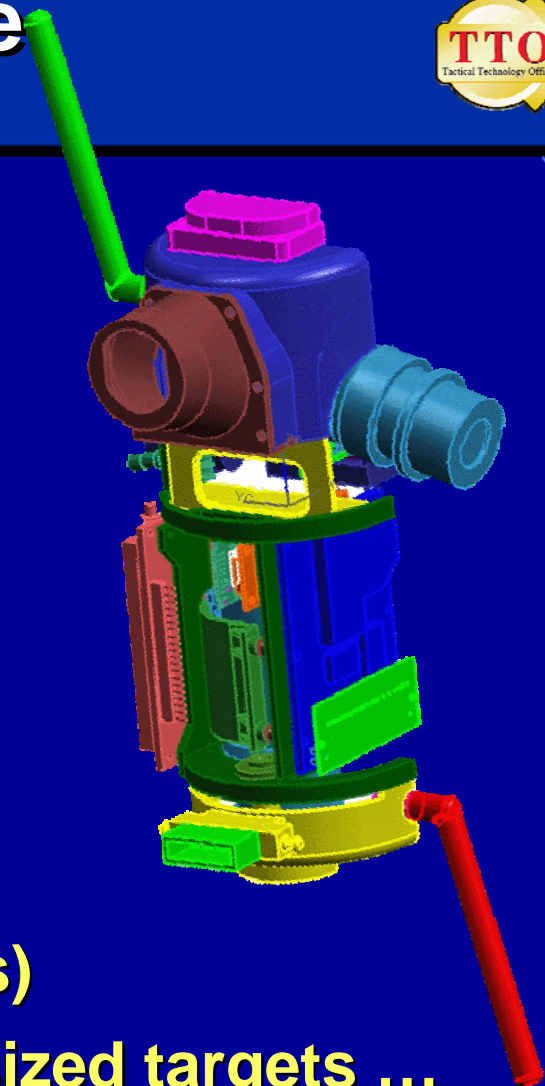
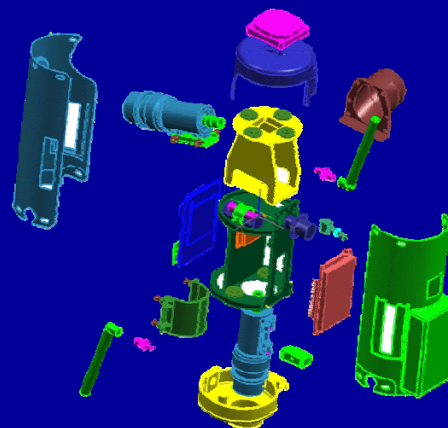



# Micro Air Vehicle

## Avionics / Communications / Navigation



- **Avionics Pod**

- **Micro Electro Mechanical Systems (MEMS)**  
Inertial Measurement System
- **Global Positioning System (GPS) receiver**
- **Flight Management Unit Processor**
- **Inertial Measurement Unit/Flight Mgt Unit (IMU/FMU)**  
*integrated commercial microprocessors with gyroscopes, magnetometer, air data sensors*
- **Power Source**
- **Inertial Measurement Unit**
- **Ground Proximity Sensor**

- **Communications**

- **Command and control**
- **Video down-feed**
- **10 Km communications range**

- **Navigation**

- **10m horizontal position accuracy - 4m pressure altitude accuracy**
- **Honeywell AHRS for GPS-denied/degraded environments**

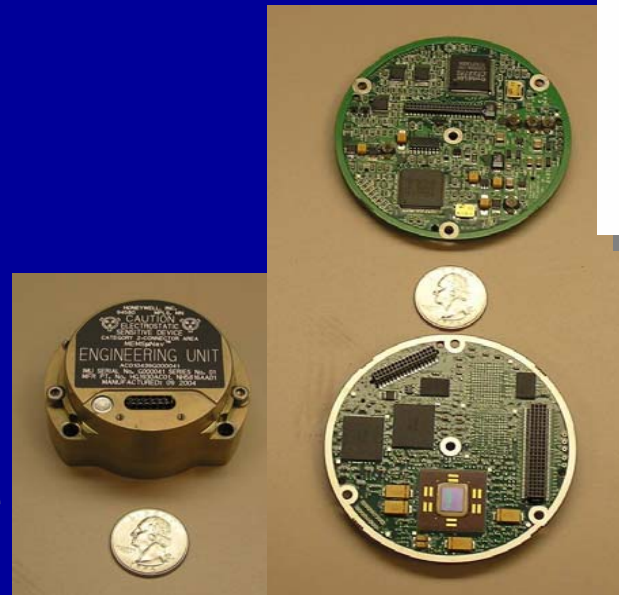
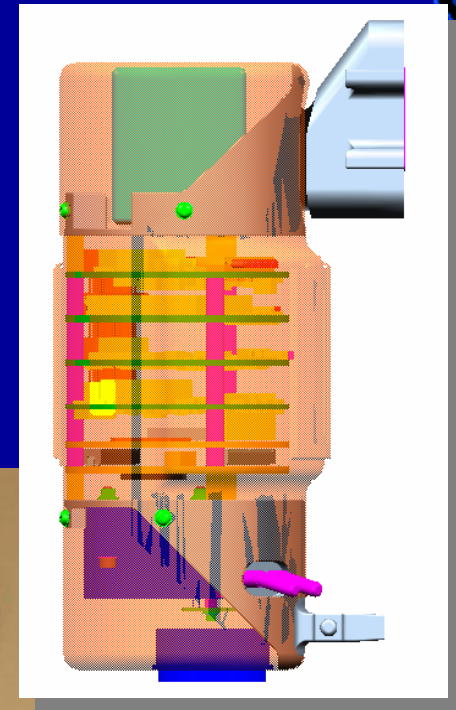





# Micro Air Vehicle Flight Modes & Flight Planning



- **Multiple Flight Modes**
  - Fully autonomous stable “hands-off”
  - Dynamically re-tasked flight from the ground station
  - Manual flight from the ground station
  - Hover-and-stare and perch-and-stare operation
  - Remote launch
- **Flight Planning**
  - Touch screen interface
  - Up to 100 waypoints per plan
  - 10 pre-planned flight plans
  - Multiple pre-programmed loiter patterns





# Micro Air Vehicle MAV Operation



- **No specialized military training (MOS) to fly or exploit imagery**
  - *Training to Operate in 24 hours*
- **Demonstrated System Maturity**
  - **Over 500 off-tether flights to date**
  - **Close quarters (below building-top) in MOUT operations in all weather, day/night conditions**
- **Demonstrated Capability**
  - **Validated as robust, portable, high endurance ISR platform**
  - **Provides platoon leader with “eyes on” NLOS “area of interest”**
  - **Deployed forward & obtained hovering EO / IR reconnaissance with no troops in harms way**
- **Continued Experimentation**
  - **Developing Techniques, Tactics, and Procedures (TTPs)**





# Military Utility Assessment



- Final experiment with CAV platoon from 2<sup>nd</sup> Bde, 25 ID in October 06
- 7 gMAV systems delivered for Unit Training
- Soldier Battle Lab managed experiment
  - Day-to-day operations
  - Data collection, review and compilation
  - Write experiment report
- ACTD OM (USARPAC G2) to write MUA report

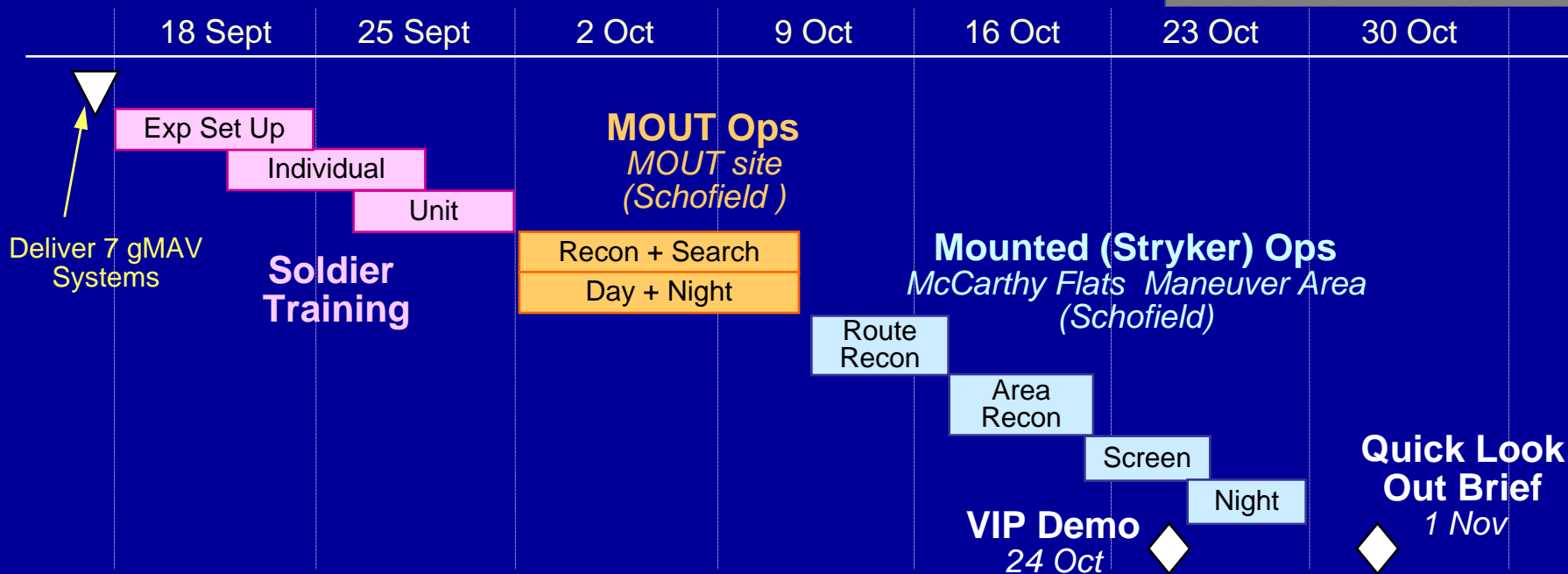





# Military Utility Assessment Operations at MOUT site, Schofield Barracks





# Micro Air Vehicle Videos

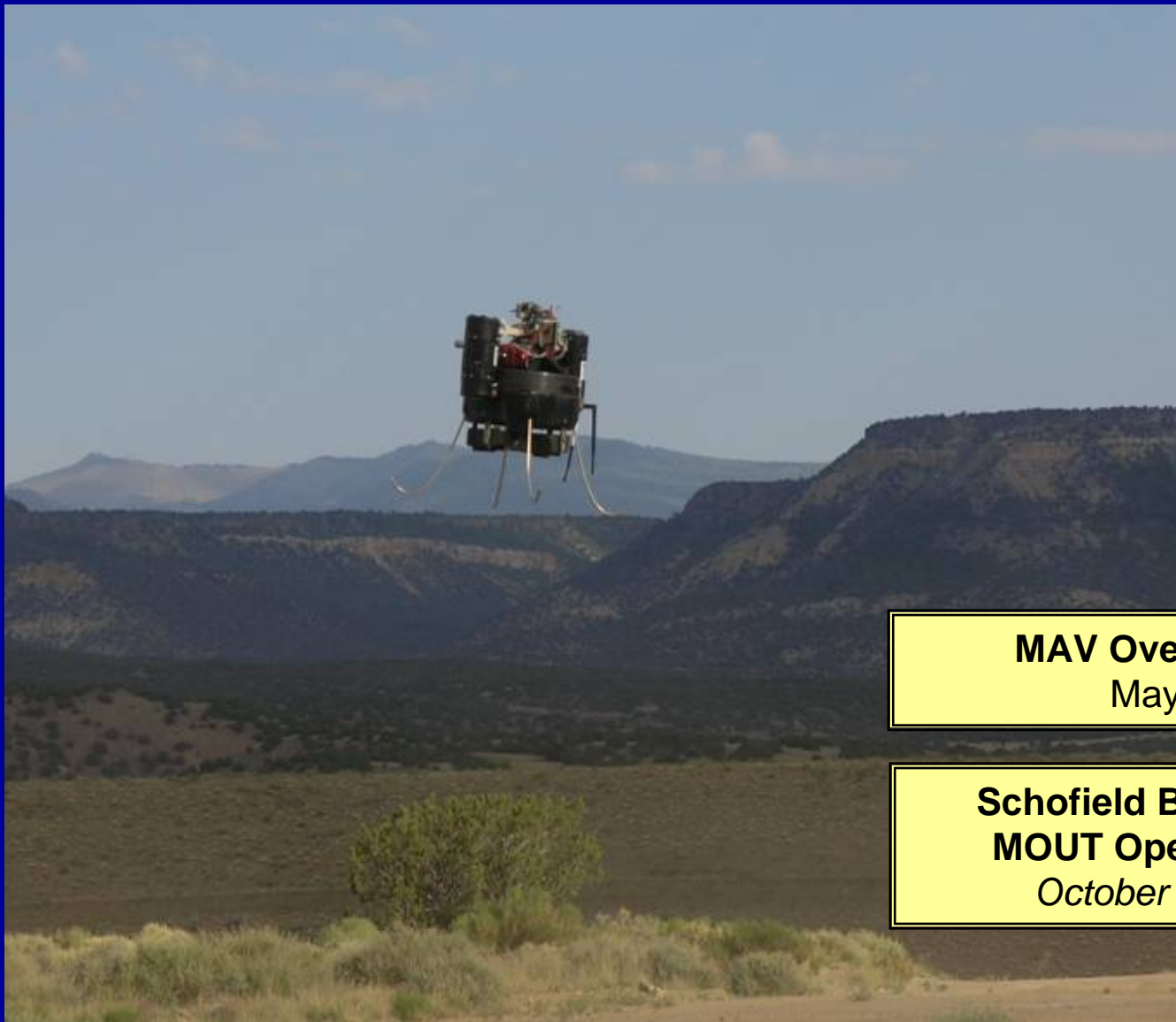

**MAV Overview**  
May

**Schofield Barracks  
MOUT Operations**  
*October 2005*



# Micro Air Vehicle Summary



- **Ducted VTOL sensor platform offers tremendous intelligence, surveillance, & reconnaissance capabilities to the modern soldier**
  - Airborne imaging while hovering and flying
  - Airborne target tracking
  - Navigation through rolling, complex, and urban terrain
  - Safe operations near soldiers, civilians and obstacles
- **Autonomous Unmanned Systems at the Platoon Level Provide High Degree of Organic Situational Awareness**
  - Rapid Response
  - Negligible operator exposure
  - Operable without Specialized Military Training (MOS)
  - Real-time maneuver to identify / confirm target as hostile military or civilian / UN / NGO
- **MAV System Offers Significant Organic Capability for Valuable Situational Awareness Provides at Platoon Level**



# Airborne Hover and Stare RSTA Technology: Civil War vs. Today

A central image showing a blue sky with a hot air balloon at the bottom and a small drone or aircraft at the top. The hot air balloon has a black envelope with colorful vertical stripes in red, yellow, and blue. The drone is a small, multi-rotor aircraft with a camera mounted underneath.

Questions?