

**APPLIED RESEARCH LABORATORY**  
The Pennsylvania State University  
Post Office Box 30  
State College, Pennsylvania 16804

Summary of Recent Hybrid Torpedo  
Powerplant Studies

by

Jonathan A. Peters

Technical Report No. 07-004  
December 2007

Supported by:  
Office of Naval Research

E. G. Liszka, Director  
Applied Research Laboratory

**20080428193**

APPROVED FOR PUBLIC RELEASE, DISTRIBUTION UNLIMITED

**REPORT DOCUMENTATION PAGE**

*Form Approved*  
OMB No. 0704-0188

The public reporting burden for this collection of information is estimated to average 1 hour per response, including the time for reviewing instructions, searching existing data sources, gathering and maintaining the data needed, and completing and reviewing the collection of information. Send comments regarding this burden estimate or any other aspect of this collection of information, including suggestions for reducing the burden, to Department of Defense, Washington Headquarters Services, Directorate for Information Operations and Reports (0704-0188), 1215 Jefferson Davis Highway, Suite 1204, Arlington, VA 22202-4302. Respondents should be aware that notwithstanding any other provision of law, no person shall be subject to any penalty for failing to comply with a collection of information if it does not display a currently valid OMB control number.  
**PLEASE DO NOT RETURN YOUR FORM TO THE ABOVE ADDRESS.**

1. REPORT DATE (DD-MM-YYYY) 11/30/2007		2. REPORT TYPE Technical Report		3. DATES COVERED (From - To)	
4. TITLE AND SUBTITLE Summary of Recent Hybrid Torpedo Powerplant Studies				5a. CONTRACT NUMBER N00014-05-G-0106	
				5b. GRANT NUMBER	
				5c. PROGRAM ELEMENT NUMBER	
6. AUTHOR(S) Jonathan A. Peters				5d. PROJECT NUMBER	
				5e. TASK NUMBER	
				5f. WORK UNIT NUMBER	
7. PERFORMING ORGANIZATION NAME(S) AND ADDRESS(ES) The Pennsylvania State University Applied Research Laboratory P. O. Box 30 State College, PA 16804-0030				8. PERFORMING ORGANIZATION REPORT NUMBER TR-07-004	
9. SPONSORING/MONITORING AGENCY NAME(S) AND ADDRESS(ES) Dr. Kam W. Ng Program Officer Office of Naval Research 875 North Randolph Street, Suite 1425, Code 333 Arlington, 22203-1995				10. SPONSOR/MONITOR'S ACRONYM(S)	
				11. SPONSOR/MONITOR'S REPORT NUMBER(S)	
12. DISTRIBUTION/AVAILABILITY STATEMENT Approved for public release, distribution unlimited.					
13. SUPPLEMENTARY NOTES					
14. ABSTRACT Hybrid torpedoes incorporate multiple propulsion subsystems, optimized for different power levels. This allows these weapons to operate more efficiently over a wide range of speeds, which may give tactical advantages in certain engagement scenarios. After a brief general discussion of the hybrid torpedo concept, a parametric analysis comparing hybrid and conventional torpedo ranges is presented. The distinctions between hybrid torpedoes and weaponized Unmanned Undersea Vehicles (UUVs) are enumerated. Powerplant component models, including the THERMHYB tool, are discussed. A trade study, performed to identify key enabling technologies for hybrid weapons, is presented. Ongoing and future efforts are described.					
15. SUBJECT TERMS					
16. SECURITY CLASSIFICATION OF:			17. LIMITATION OF ABSTRACT None	18. NUMBER OF PAGES	19a. NAME OF RESPONSIBLE PERSON
a. REPORT Unclassified	b. ABSTRACT Unclassified	c. THIS PAGE Unclassified			19b. TELEPHONE NUMBER (Include area code)

## ABSTRACT

Hybrid torpedoes incorporate multiple propulsion subsystems, optimized for different power levels. This allows these weapons to operate more efficiently over a wide range of speeds, which may give tactical advantages in certain engagement scenarios. After a brief general discussion of the hybrid torpedo concept, a parametric analysis comparing hybrid and conventional torpedo ranges is presented. The distinctions between hybrid torpedoes and weaponized Unmanned Undersea Vehicles (UUVs) are enumerated. Powerplant component models, including the THERMHYB tool, are discussed. A trade study, performed to identify key enabling technologies for hybrid weapons, is presented. Ongoing and future efforts are described.

## ACKNOWLEDGEMENTS

This report summarizes the results of a number of programs performed under the sponsorship of the Office of Naval Research. In each case, Dr. Kam Ng served as the program manager. Contracts / Deliver Orders include N00014-00-G-0058/0026, N00014-00-G-0058/0053, N00014-00-G-0058/0066, N00014-00-G-0058/0080, N00014-05-G-0106/0017, N00014-05-G-0106/0046 and N00014-05-M-0182.

The hydrodynamic work described in Section 6 was performed by Mr. Steven Willits of ARL, who supplied the text and figures found in this section. The preliminary battery evaluation study was performed by Mr. Sekou Wilson of ARL.

## TABLE OF CONTENTS

ABSTRACT.....	1
ACKNOWLEDGEMENTS.....	1
TABLE OF CONTENTS.....	2
LIST OF FIGURES.....	4
LIST OF TABLES.....	4
1. INTRODUCTION.....	5
1.1 Potential Hybrid Torpedo Missions.....	7
1.2 Hybrid Torpedoes and Weaponized UUVs.....	8
2. HYBRID TORPEDO PERFORMANCE MODELING.....	10
2.1 Dimensionless Analysis.....	10
2.2 Comparing Hybrid and Conventional Weapons.....	13
3. COMPONENT MODEL DEVELOPMENT.....	15
3.1 THERMHYB Program.....	15
3.2 Battery Systems.....	16
4. DETAILED HYBRID TORPEDO TRADE STUDY.....	19
4.1 Overview of Study Parameters.....	19
4.2 Summary of Trade Study Conclusions.....	20
5. BUOYANCY CONSIDERATIONS.....	20
6. HYDRODYNAMIC STUDIES.....	22
7. SUMMARY.....	25
8. FUTURE PLANS.....	25
REFERENCES.....	26
APPENDIX A: DETAILED DESCRIPTION OF HYBRID TORPEDO TRADE STUDY.....	A1
A.1 INTRODUCTION.....	A1
A.2 HYBRID SYSTEM COMPONENTS AND COMPONENT MODELS FOR SBD TRADE STUDIES.....	A1
A.2.1 Overall Vehicle.....	A1
A.2.2 Fuels.....	A2
A.2.3 Oxidizers.....	A3
A.2.3.1 3000 PSI Gaseous Oxygen (GOX).....	A4
A.2.3.2 Liquid Oxygen (LOX).....	A6
A.2.3.3 Chemical Oxygen Storage.....	A7
A.2.3.4 Oxidant and Fuel Storage Subsystems.....	A9
A.3 HIGH POWER ENERGY CONVERSION SYSTEMS.....	A9
A.3.1 Open Cycle Engine (OC).....	A10
A.3.2 Semi Closed Cycle Rankine (CCR).....	A10
A.3.3 Open Combustor Closed Cycle Rankine.....	A10
A.4 LOW POWER ENERGY CONVERSION SYSTEMS.....	A11
A.4.1 Mini Turbine.....	A11
A.4.2 PEM Fuel Cell.....	A12
A.4.3 Solid Oxide Fuel Cell.....	A12
A.5 SUBCOMPONENT MODELS.....	A13
A.6 BUOYANCY CONCERNS.....	A13

A.6.1 Neutrally Buoyant Systems.....	A13
A.6.2 "Winged" Systems.....	A13
A.7 CANDIDATE SYSTEMS .....	A14
A.8 TRADE STUDY RESULTS.....	A17
A.8.1 Metric #1: Range at Low Power .....	A17
A.8.2 Metric #2: Range at High Speed.....	A18
A.8.3 Metric #3: Mission of Record.....	A18
A.9 TRADE STUDY CONCLUSIONS.....	A23
REFERENCES: APPENDIX A.....	A25

## LIST OF FIGURES

Figure 1: Conceptual Hybrid HAC System .....	6
Figure 2 Range Multiplier vs. $\beta'(\eta_H/\eta_L)$ .....	12
Figure 3: Hybrid vs. Conventional Torpedo Range Showing Effect of Design High Speed .....	13
Figure 4: Hybrid vs. Conventional Torpedo Range Showing Effect of Design Low Speed .....	14
Figure 5: Open Combustor / Closed Cycle Rankine (OCCCR) System (Herr, 2002).....	16
Figure 6: COTS Batteries Tested.....	17
Figure 7: Fuels, Oxidizers and High / Low Power Conversion Systems Considered for Trade Study.....	19
Figure 8: Buoyancy and Effective Energy Density .....	22
Figure 9: Component Drag Contributions and Net Drag of a Notional "Winged" Torpedo .....	23
Figure 10: Lift-to-Drag Ratio of a Notional "Winged" Torpedo .....	24
Figure 11: Power Required of a Notional "Winged" Torpedo .....	24
Figure A1: Size of Heavyweight Torpedo Assumed for Trade Studies .....	A2
Figure A2: Candidate Oxygen Storage Media.....	A4
Figure A3: Low Speed Range of Neutrally Buoyant GOX-Based Systems.....	A5
Figure A4: Cross Section of Hybrid Torpedo Showing Volume Allocated for Wing...	A14
Figure A5: Component Volumes - Neutrally Buoyant Systems.....	A19
Figure A6: Component Weights - Neutrally Buoyant Systems.....	A19
Figure A7: Component Volumes - "Winged" Systems .....	A20
Figure A8: Component Weights - "Winged" Systems .....	A20
Figure A9: Ranges for Neutrally Buoyant Systems With Oxygen Source Identified (Lack of Arrow Implies 3000 PSI GOX Storage).....	A21
Figure A10: Ranges for "Winged" Systems With Oxygen Source Identified (Lack of Arrow Implies GOX Storage).....	A21

## LIST OF TABLES

Table 1: Hybrid Torpedoes and Weaponized UUVs .....	9
Table 2: Component Models Developed at ARL .....	18
Table A1: Subcomponent Model Assumptions .....	A15
Table A2: System Configuration Matrix .....	A16
Table A3: Impact of Key Technologies.....	A22

## 1. INTRODUCTION

Hybrid propulsion systems offer increased efficiency over a broad range of power levels when compared to conventional systems, which tend to operate with reduced efficiency at off-design conditions. Hybrid automobiles represent the most familiar use of this technology. In a typical hybrid automobile, an electrical subsystem supplements an internal combustion engine, particularly at the demanding high torque / low speed operating regime encountered when starting from a dead stop. Because an electric motor operates quite efficiently at this condition, it is possible to reduce the size of the internal combustion engine, resulting in an overall improvement in fuel economy.

A hybrid torpedo also incorporates multiple powerplants and/or propulsors, with one of these systems optimized for very low speed operation. By improving efficiency at low speeds, it is possible to achieve tremendous increases in overall range while still retaining the ability for a high speed operation (i.e. for attack or high speed transit). These improvements in endurance and operating envelope should allow hybrid torpedoes to perform a wide range of current and future missions. This flexibility may offer increased weapon effectiveness (as measured by such metrics as probability of kill  $P_k$ ), and will allow hybrid torpedoes to more effectively perform missions that take advantage of emerging technologies such as improved sensors, enhanced weapon-platform connectivity and advances in battle space awareness.

Figure 1 shows a schematic for a conceptual hybrid powerplant. This device incorporates a high power system similar to that being developed by the DARPA funded "Hybrid Aluminum Combustor" program. The HAC system burns aluminum powder with seawater to produce a mixture of steam and hydrogen which is then expanded through a turbine to drive a propulsor shaft.

To make a hybrid system from the basic HAC powerplant, low-power conversion system components are added. These additional components are shown in color in Figure 1, with the original HAC system shown in shades of gray. The low-power system utilizes a reactor that consumes aluminum fuel and a hydroreactive oxygen source to produce  $H_2$  and  $O_2$  gases, which are in turn combined in a fuel cell to produce electricity to drive an electric motor.

Because fuel cells and electric motors operate very efficiently, this type of hybrid offers the potential for excellent endurance at low speed. Since the fuel cell, power electronics and motor components would be prohibitively large and heavy if sized for high power, it is also necessary to incorporate the high power HAC system, which includes a combustor, turbine, condenser and ancillary equipment.

Figure 1 illustrates some of the tradeoffs associated with hybrid propulsion systems. The improved efficiency of the hybrid powerplant is offset to some extent by the need to carry two propulsion systems. While a number of components of the HAC-Hybrid system are used by both the high and low power subsystems, the hybrid vehicle still contains more equipment than a conventional torpedo.<sup>1</sup> The added weight and volume of these components reduces the amount of fuel and/or oxidizer that can be carried.

---

<sup>1</sup> Please note that the HAC system is currently being developed for a UUV application. Further work is required to determine if the complexity of the system shown in Figure 1 would make it suitable for torpedo applications.

It should be recognized that hybrid torpedoes perform some of the same type of missions as UUVs (Unmanned Undersea Vehicles) and, in fact, most weaponized UUVs are hybrid systems, albeit ones in which the low speed and high speed mission segments are performed by different vehicles. Many of the performance and design considerations discussed in this report in the context of hybrid torpedoes apply directly to weaponized UUVs as well. The following section discusses the similarities and differences between these two hybrid configurations in more detail.

Whether applied to automotive or torpedo applications, the design of a hybrid system represents a series of compromises between ultimate performance and increased flexibility. Because of this very complex tradeoff, Simulation Based Design / Multidisciplinary Design and Optimization (SBD/MDO) techniques must be applied in order to optimize the selection of hybrid weapons system designs as measured by their impact on naval operations. The work discussed in this report is intended to facilitate this process by providing “domain expertise” on hybrid systems to the SBD/MDO community.

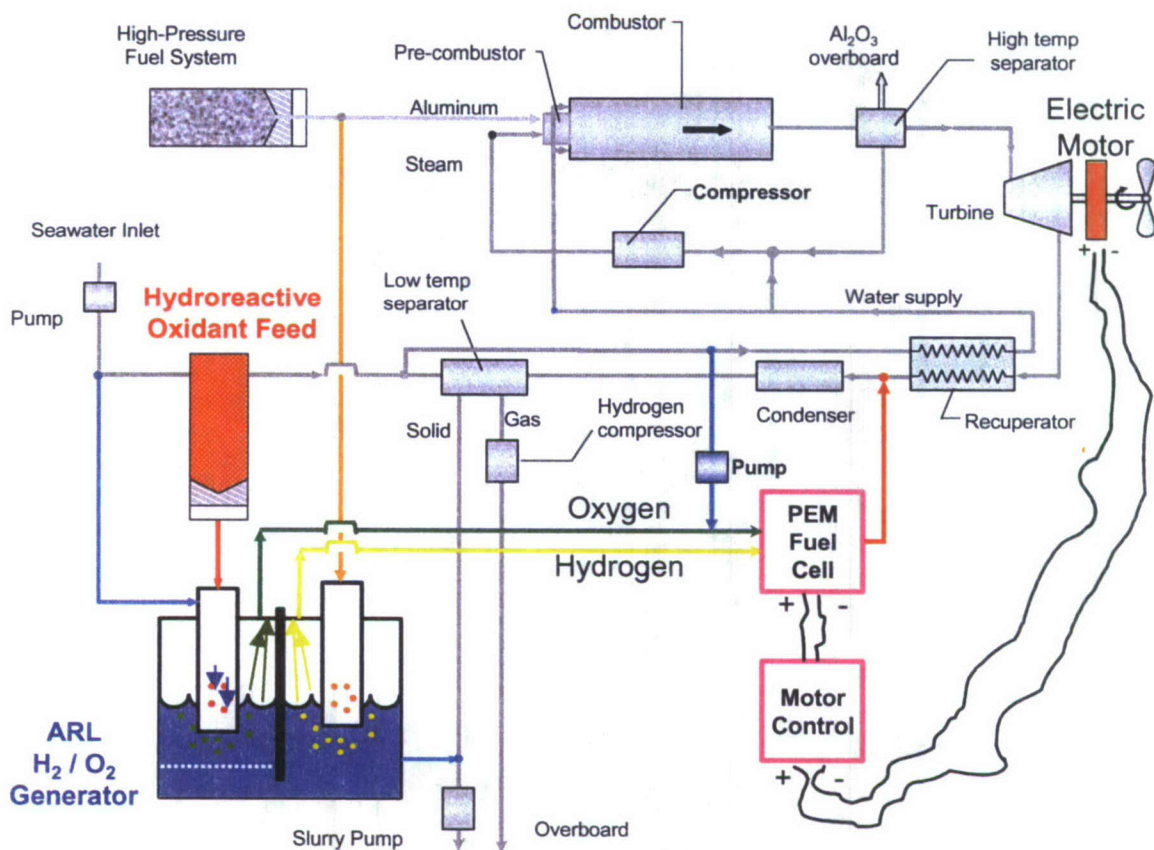

Figure 1: Conceptual Hybrid HAC System



## 1.1 Potential Hybrid Torpedo Missions

The tactical impact of both hybrid torpedoes and weaponized UUVs will probably be felt most strongly in missions that;

- Take advantage of the increased range of these systems to allow the host platform (SSN or SSGN) to operate at some distance from potential threats, particularly in environments that favor SSKs relative to SSNs
- Use the increased endurance of these systems to allow a single SSN or SSGN platform to position weapons over a broad area, effectively multiplying the effectiveness of the host platform.

Some examples of specific mission scenarios include;

- Long duration search at low speed followed by high-speed attack run against selected underwater or surface target.
- Fast transit from safe standoff range, followed by long duration low speed search (i.e. for bottomed SSK).
- Standoff launch and transit to “patrol” area followed by attack or second transit, possibly using third-party targeting and cueing information (i.e. from distributed sensor network or from aircraft monitoring sonobuoys).
- Launch of lightweight torpedo by aircraft standing off from target to minimize SUBSAM threat.
- Traditional ‘Blue Water’ type engagement with a relatively short duration acquisition period followed by a high-speed chase against a fast SSN opponent.

Because they operate efficiently over a wider range of power levels than conventional systems, hybrid undersea weapons (both torpedoes and weaponized UUVs) will be capable of more effectively performing this increasingly diverse mix of missions. This will translate into improved performance, as measured by the  $P_k$  and  $P_{ck}$ . Since hybrids can be adapted to new tasks as the Navy’s mission evolves, they will offer life cycle cost savings relative to “single purpose” conventional weapons.

Hybrid Undersea weapons represent a compromise between traditional performance metrics (i.e. speed, range, maximum operating depth) and the ability to prosecute a wider range of missions. This tradeoff between performance and flexibility means that hybrid system designs must be optimized to maximize  $P_k$  and  $P_{ck}$ . It is therefore essential that domain data for hybrid systems be integrated into evolving SBD/MSDO models.

In order to realize their full potential, hybrid torpedoes and weaponized UUVs will require either a great deal of autonomy or will need to communicate with other assets either acoustically or by surfacing and deploying RF antennae. Either weaponized UUVs or hybrid torpedoes could function as components of a PLUSNET network or through peer-to-peer contact with their launch platform and/or other assets. Regardless of the communication mechanism and protocol used, the

ability to send and receive updated targeting information and, particularly, to receive permission to fire weapons (WUUV) or commence attack mode (hybrid torpedo) is an essential enabler for these systems.

## **1.2 Hybrid Torpedoes and Weaponized UUVs**

Table 1, below summarizes some of the key distinctions between weaponized UUVs and hybrid torpedoes. The major differences in the performance envelopes (and consequently in the types of tactical situations in which they are likely to perform) have to do with scale; a weaponized UUV is likely to be considerably larger than a hybrid torpedo. This increased volume should translate into greater endurance for a given warhead load or a greater warhead load (probably distributed on multiple weapons) for a given range. It is likely that the increased size of a weaponized UUV will allow improved sensor capabilities as well as better communications.

While these factors tend to make weaponized UUVs more capable and flexible than hybrid torpedoes, the latter have the advantages of being compatible with more platforms and therefore easier to integrate into the existing fleet, do not require UUV launch and recovery operations, and can be carried more compactly without compromising existing missions (since a hybrid torpedo is capable of performing most of the conventional missions of the HWT torpedo that it would displace).

In summary, hybrid torpedoes and weaponized UUVs are similar concepts that may offer significant tactical advantages in some situations. Definition of CONOPS and the resulting optimal configurations for both of these systems requires simulations at the tactical (war-game) level.

**Table 1: Hybrid Torpedoes and Weaponized UUVs**

<b>Factor</b>	<b>Hybrid Torpedo</b>	<b>Weaponized UUV</b>	<b>Comment</b>
Overall Size / Launcher	Upper limit on size is current HWT (21") size / configured for current SSN, SSGN, SSBN tubes	Most likely configurations tend to be larger than HWT / probably focus on D5 missile tubes on SSGN platforms. May be applicable to surface ship (LCS) implementation	Hybrid torpedoes can be deployed on more platforms than weaponized UUVs.
Weight	May be heavier than displaced seawater (non-neutrally buoyant)	More likely to be constrained to neutral buoyancy than torpedo	See "low speed"
Fuel / Oxidizer Selection	Premium placed on stable shelf life, energy density  High and low power systems probably share same fuel / oxidizer	Less emphasis on long-term storage, more focus on refueling. Specific energy is more important than energy density  Low power (UUV) and high power (weapon) propulsions systems draw from distinct fuel / oxidizer stores	Hybrid torpedoes inherently have complete flexibility in $F_R$ (fraction of mission performed at high speed). All fuel can be expended in torpedo-like burst. Conversely, the range of the attack phase of a weaponized UUV system is fixed.
Low Speed	Optimized for mission, but likely governed by most efficient search speed. Considerably slower than current HWT torpedoes. Neutral buoyancy may not be necessary or optimal	Likely to be even slower than hybrid torpedo. Stationkeeping, drift or bottoming modes are probably desirable. Neutral buoyancy of overall system is probably required.	Larger size of UUV platform should allow more effective sensors and communications, which may favor very low-speed or drift-mode operations.
High Speed	Slower than current HWT torpedoes but still relatively fast. Governed by likely targets and CONOPS	Highest speed of UUV platform is likely to be relatively slow. Weapon speed depends on configuration but is likely to be comparable to current torpedoes	
Range	Much greater than current torpedoes. Range depends on mission mix ( $F_R$ ) and can vary from full torpedo mode ( $F_R = 1$ ) to full "UUV" mode ( $F_R = 0$ )	Larger size of weaponized UUV should translate into increased overall range compared to hybrid torpedo. Ranges of weapon and UUV are fixed and independent	For a given package size, hybrid torpedoes should have better range than weaponized UUVs. A 21" weaponized UUV is probably not practical as performance penalties associated with carrying separate weapons systems impacts smaller vehicles disproportionately
Sensors	Small size of vehicle probably puts emphasis on active sonar	Larger vehicle size increases available sonar aperture, may improve performance of passive sonar. Use of synthetic aperture sonar or even towed arrays is possible.	Active sonar in hybrid torpedo increases optimal search speed.

## 2. HYBRID TORPEDO PERFORMANCE MODELING

A focus of this multi-year effort has been the development of models to predict the performance of hybrid torpedoes. This task has progressed from a general analysis in which the performance of hybrid weapons is expressed in terms of nondimensional groupings to a more detailed analysis, involving broad assumptions about powerplant volumes, efficiencies, etc., intended to capture the tradeoffs associated with hybrid powerplants. The culmination of this task is a detailed trade study that attempted to capture size and performance data for individual powerplant components to identify the key technologies that have the potential to improve the performance of future hybrid weapons.

### 2.1 Dimensionless Analysis

ARL has used the following expression to define the range of a conventional torpedo system:

$$Range = \frac{(\rho_{EXP} Vol_{EXP} \Delta H_{Reac} - f_L) \eta_C}{C V^{n-1} + \frac{f_A}{V}} \quad [1]$$

Where;

$\rho_{EXP}$	= Density of expendables (i.e. fuel and oxidizer)
$Vol_{EXP}$	= Volume of expendables
$\Delta H_{Reac}$	= Heat of reaction of fuel / oxidizer mixture (mass basis)
$f_L$	= Heat loss
$f_A$	= Auxiliary (hotel) power
$\eta_C$	= Thermal efficiency of conversion system
$V$	= Speed
$CV^{n-1}$	= Expression for power as a function of speed (in most cases $n \cong 3$ )

Note that the term  $(\rho_{EXP} \Delta H_{Reac})$  is defined as the energy density of the reactants.

In a hybrid torpedo<sup>2</sup> the range can be expressed as a function of several dimensionless groups as follows:

---

<sup>2</sup> These analyses assume a hybrid powerplant configured so that both conversion systems draw from the same fuel/oxidizer supply. Under some circumstances, separate energy storage systems will be used for each conversion system. In this case the range is calculated as the sum of the ranges of two conventional systems by applying equation 1 twice.

$$Range = \frac{(\rho_{EXP} Vol_{EXP} \Delta H_{Reac}) \eta_H}{(P_{High} + f_A) / V_H} \cdot \frac{1}{(1 - F_R) \cdot \beta \left( \frac{\eta_H}{\eta_L} \right) + F_R}$$

Where;

[2]

$$\beta = \frac{(P_L + f_A) \cdot V_H}{(P_H + f_A) \cdot V_L}$$

Note that the subscripts "H" and "L" refer to the high and low power conditions, respectively and that:

$F_R$  = Fraction of range prosecuted at high speed (e.g.  $V_H$ )  
 $P_H, P_L$  = High and low power, respectively

The first group of terms in Equation 2 is identical to Equation 1 if the loss term is neglected. The second term is a nondimensional range multiplication factor that is itself a function of the dimensionless groups  $\beta$  and  $\eta_H/\eta_L$  and the mission parameter  $F_R$ .

If hotel power is small relative to  $P_L$  and the power is roughly proportional to the cube of vehicle speed, then:

$$\beta \cong \left[ \frac{V_L}{V_H} \right]^2$$

Note that Equation 2 neglects the energy loss term  $f_L$ . If the loss for each conversion system can be expressed as a steady heat flux ( $Q_L$  and  $Q_H$ , respectively), then the range is represented by:

$$Range = \frac{(\rho_{EXP} Vol_{EXP} \Delta H_{Reac}) \eta_H}{(P_{High} + f_A + Q_H \eta_H) / V_H} \cdot \frac{1}{(1 - F_R) \cdot \beta' \left( \frac{\eta_H}{\eta_L} \right) + F_R}$$

Where;

[3]

$$\beta' = \frac{(P_L + f_A + Q_L \eta_L) \cdot V_H}{(P_H + f_A + Q_H \eta_H) \cdot V_L}$$

Equation 3 reflects the increase in range associated with low-speed operation for both hybrid and conventional torpedo systems. For conventional systems, the off-design efficiency  $\eta_{OD}$  is used in place of  $\eta_L$  (typically  $\eta_{OD} < \eta_H < \eta_L$ ).

Figure 2 shows the range multiplier (the range of a given hybrid system compared to the range if the same system were run at full speed to fuel exhaustion) as a function of  $F_R$  and  $\beta' \eta_H / \eta_L$ . The mission parameter  $F_R$  has a strong influence on the increase in range that can be realized by varying  $\beta' \eta_H / \eta_L$ . If 90% of the mission range is covered at low speed ( $F_R = 0.1$ ), the range can increase by as much as an order of magnitude relative to high-speed operation. If only half of the mission range is covered at low speed ( $F_R = 0.5$ ), the range can increase by at most a factor of two. Lower values of  $\beta' \eta_H / \eta_L$  reflect increased low speed efficiency  $\eta_L$  and/or reduced low-speed power  $P_L$ , which can be achieved with a hybrid configuration.

The net result is that the potential increase in range resulting from improvements in low speed performance depends on the missions that future torpedoes will be called upon to perform. If the tactics that develop as a response to future threat scenarios result in relatively low values of  $F_R$ , the development of hybrid torpedo propulsion systems may have a very large range payoff.

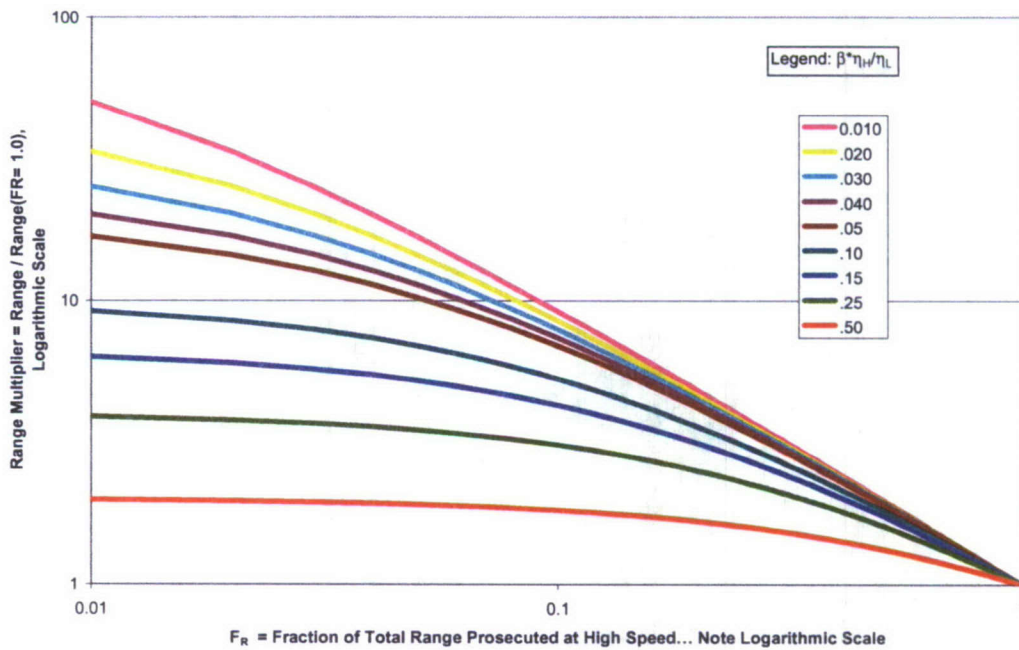

Figure 2: Range Multiplier vs.  $\beta'(\eta_H/\eta_L)$

## 2.2 Comparing Hybrid and Conventional Weapons

While hybrid torpedoes offer potential improvements in range, the benefit of including a second conversion system must be weighed against the weight and volume penalties associated with these additional components, which reduce the amount of expendables that can be carried. A spreadsheet application was developed to compare the ranges of volume-limited hybrid and conventional torpedo propulsion systems.

Although this model can be adapted to any combination of propulsion system components, the analyses discussed below assume a 33% efficient regenerated Rankine cycle for high-speed operation, with a 55% efficient PEM-type fuel cell for low speed operation. The tool implements Equation 3 to predict both hybrid and conventional system ranges. Although this is a fairly simple equation, there are a large number of parameters that can be varied independently to affect range. The HYBRANGE Excel add-in program was developed to facilitate the process of comparing hybrid and conventional systems by automatically generating plots of dependent variables such as range against various combinations of independent variables.

A sensitivity analysis was performed to evaluate the effects of the parameters that appear as independent variables in Equation 3. For most values of  $F_R$ , hybrid range can be affected most dramatically by differential changes in  $f_A$ ,  $Q_L$  and  $V_L$ , while conventional torpedo range is most sensitive to  $f_A$ ,  $\eta_H$  and  $V_H$ . Figures 3 and 4 are HYBRANGE plots showing the effects of  $V_H$  and  $V_L$ , respectively.

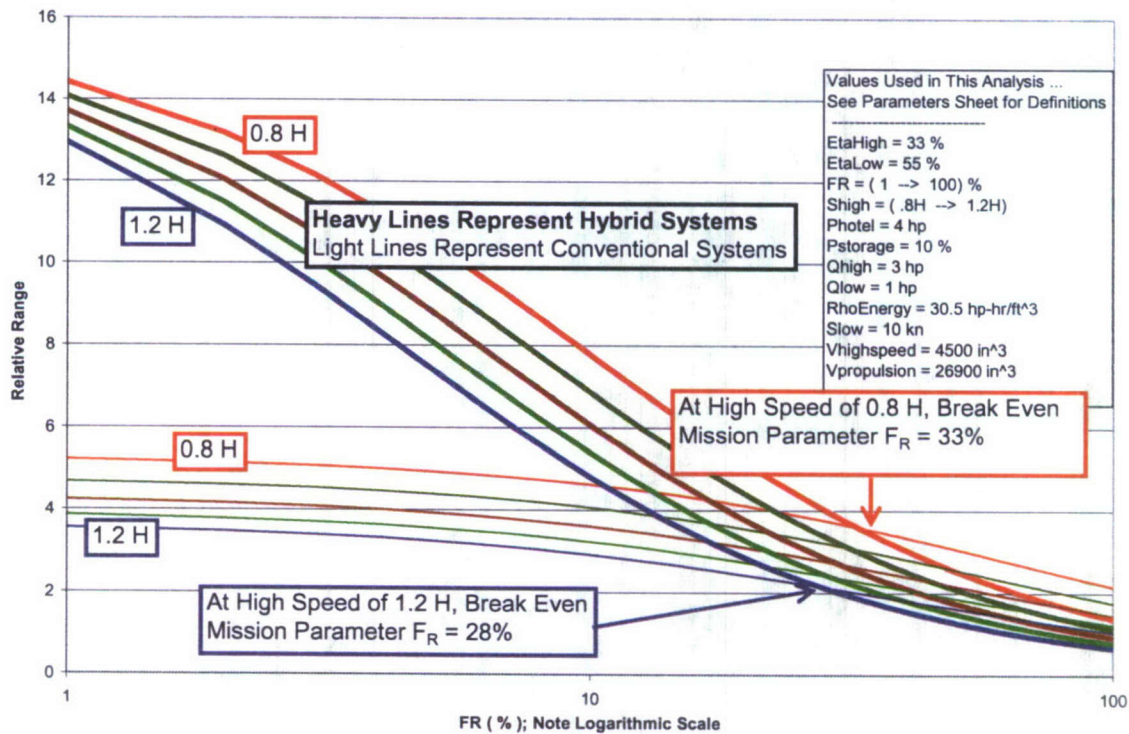
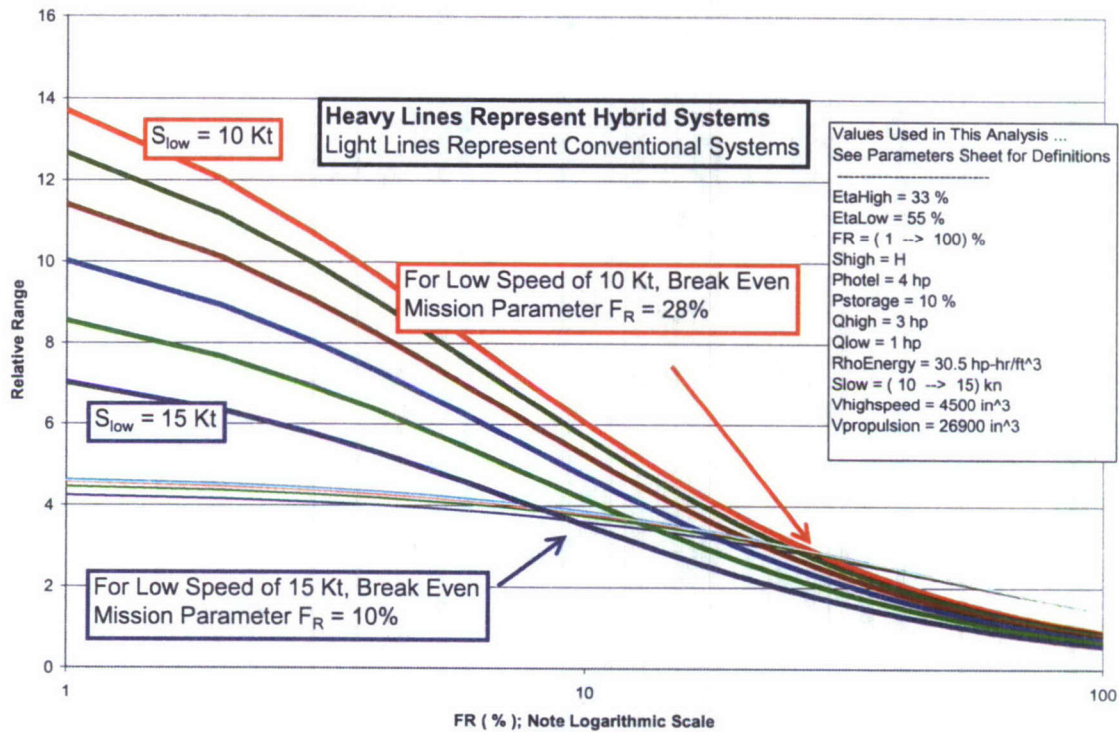

Figure 3: Hybrid vs. Conventional Torpedo Range Showing Effect of Design High Speed



**Figure 4: Hybrid vs. Conventional Torpedo Range Showing Effect of Design Low Speed**

For every condition plotted in these figures there is a break-even point at which the range curves for the hybrid and conventional systems intersect. For example, Figure 3 compares the range as a function of high speed ( $V_H$ ). The break-even point ranges from  $F_R = 28\%$  (for  $V_H = 1.2H$ ) to  $33\%$  ( $V_H = 0.8H$ ). For the assumptions made in this study, therefore, conventional torpedoes will outperform hybrids on a range basis if more than a third of the mission range is prosecuted at high speed and the design low speed is 10 knots for more.

As torpedo missions evolve, it is possible that metrics other than range will be more important bases for comparison between hybrid and conventional systems. For example, a mission against a bottomed SSK in the littoral environment might benefit more from increased search time than improved range. Because of their low fuel consumption, hybrids typically outperform conventional torpedoes in terms of search time or time on station, although their low speed may result in reduced swept volume.

Ultimately, performance characteristics such as range and search time are subordinate to kill probability ( $P_k$ ) in terms of predicting the performance of hybrid or conventional torpedoes in an actual conflict. It is possible that the torpedo with the highest  $P_k$  over the mix of future torpedo missions will be one that is optimized for neither range nor speed but has features that allow it to adequately address the largest variety of threats.



### 3. COMPONENT MODEL DEVELOPMENT

Over the course of this multi-year investigation, analyses of hybrid torpedo performance have progressed from the nondimensional formulation described in a previous section to parametric studies, such as the one summarized in Figures 3 and 4, that incorporate broad assumptions about powerplant scaling.

These studies have identified the need for improved modeling to adequately capture the effects of various operating parameters on hybrid (and conventional) torpedo performance. As an example, the data shown in Figures 3 and 4 assumes constant volumes for the high and low power energy conversion systems, while in reality these would almost certainly scale as functions of design power. To address these issues, a major component of this multi-year effort has been the collection of simulation tools for components and subsystems of hybrid torpedo powerplants with the goal of enabling the development of system level models that can capture the effects of a wide range of operating parameters such as power, depth, etc.

Both NUWC-NPT (Roberts, 2006) and ARL have contributed to this effort, with NUWC tending to focus on batteries and electric motors and ARL on thermal conversion system components. ARL's contributions to this component model collection are summarized in Table 2, below.

#### 3.1 THERMHYB Program

A major thrust of ARL's effort has been the development of a software tool that incorporates a database of thermodynamic and physical data for hundreds of chemical species of interest as fuels or oxidizers (or monopropellants) in underwater powerplants.

This THERMHYB package is described more fully in an unpublished Internal Memorandum (Peters, 2003).<sup>3</sup> It predicts heat of reaction values (the parameter  $\Delta H_{\text{Reac}}$  of Equation 3) for chemical reactions involving the approximately 1800 species in the JANAF Thermochemical Tables (Chase, et. al., 1986). A subsidiary database contains relevant physical property data for approximately 150 species of interest for underwater propulsion applications. For reactions involving species in this smaller database, the program can predict the specific energy and energy density (energy released per unit mass of reactants and energy released per unit volume of reactants, respectively).

Finally, THERMHYB contains subroutines that perform thermodynamic cycle analyses of several important engines including a Rankine cycle engine (such as the one used in SCEPS), a generic open-cycle expander engine that operates on a mixture of combustion products, a Brayton cycle engine and an open combustor / closed cycle Rankine engine such as the one shown schematically in Figure 5, below. These analyses predict energy density and specific energy values on the basis of shaft work, i.e. the product of the respective values and the engine efficiency.

Recent enhancements to this package include the ability to specify the use of cooled products as a combustor diluent (as in the cycle shown in Figure 5), the ability to predict off-design performance for steam turbine engines, and the ability to solve for reactant compositions needed to achieve a specified temperature.

---

<sup>3</sup> Since this document does not address recent enhancements, it is anticipated that an updated IM will be developed in the current fiscal year, with a publicly-releasable Technical Report version to follow.

The THERMHYB package has been used successfully to support a number of powerplant development efforts for various underwater vehicles. Because the subsidiary database is designed to easily accommodate additional species, and because the software is set up in a modular fashion that allows additional conversion system subroutines to be added, it is anticipated that this package will continue to be a useful tool as future underwater powerplant designs evolve.

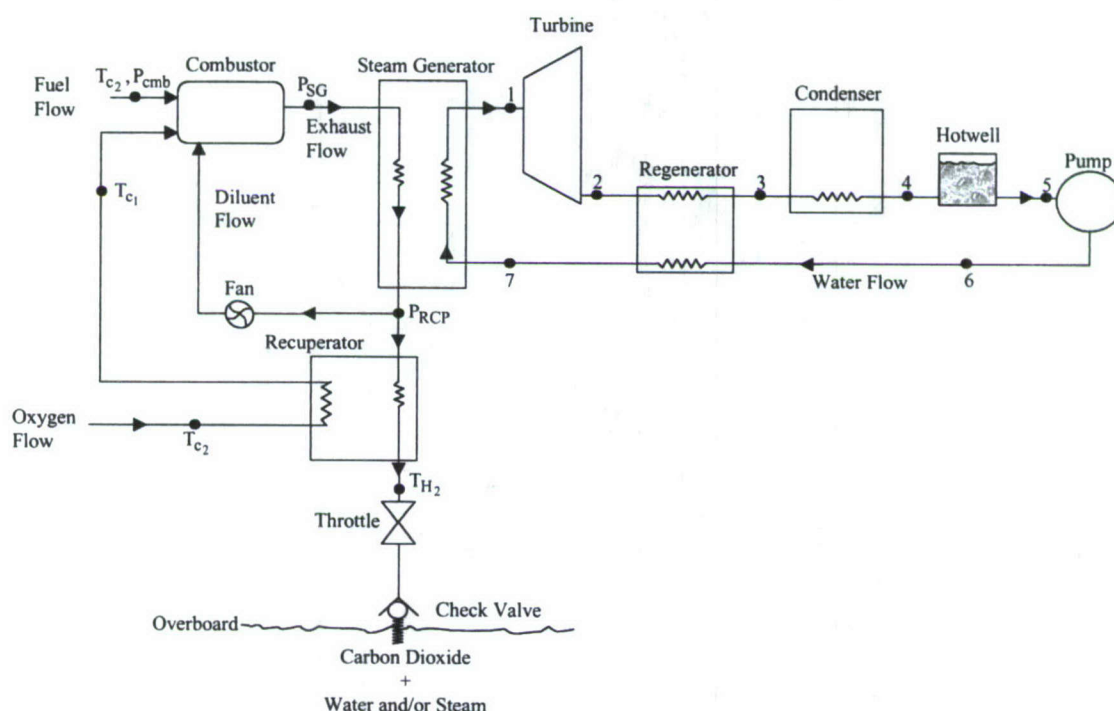

Figure 5: Open Combustor / Closed Cycle Rankine (OCCCR) System (Herr, 2002)

### 3.2 Battery Systems

Electrochemical energy storage / conversion equipment may play an important role in future hybrid torpedoes or weaponized UUVs. Even vehicles configured to include only thermal components for propulsion power are likely to incorporate batteries to facilitate startup, provide power for extended periods of dormancy, serve as a buffers for load leveling during periods of active sonar operation, etc.

For this reason, a study was undertaken to evaluate COTS secondary batteries to determine how closely they adhere to their performance specifications and how their energy density is affected by load. Mr. Sekou Wilson, then an Engineering Intern at the Applied Research Laboratory, performed this study. The FY '2006 Hybrid System Concept Development program (contract / delivery order number N00014-05-G-0106/0017) provided support for this effort through the purchase of batteries, chargers and incidental test hardware.

Batteries tested in this effort included "AA" and "D" size NiMH and "AA" size Li-Ion cells. At the end of the year, this effort transitioned into testing very large (60 AH) Li-Ion cells. Figure 6 shows the range of cells evaluated in this effort.

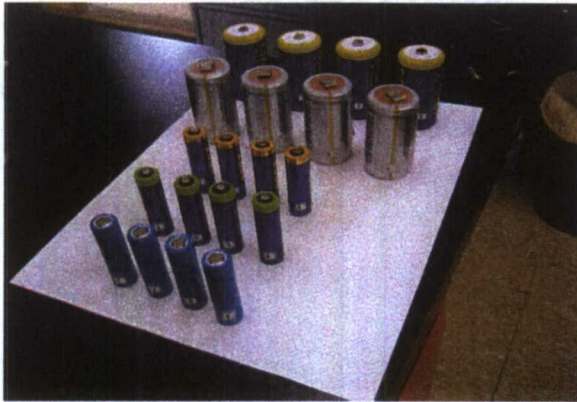

**Figure 6: COTS Batteries Tested.**

**Left, from top to bottom: 11000mAh NiMH batteries, 9000mAh NiMH batteries, 2600mAh NiMH batteries, 1800mAh NiMH batteries, and 750mAh LiIon batteries.  
Right: 60Ah LiIon batteries**

Evaluation of the larger batteries is continuing as part of a separate program. Preliminary results show that energy density values are relatively unaffected by discharge rate over a significant range of discharge currents, essentially validating the manufacturer's specifications.

**Table 2: Component Models Developed at ARL**

<b>Component / Subcomponent</b>	<b>Basis</b>	<b>Comments</b>
Complete Turbine Engine (Turbine + Housing + Regenerator + Gearbox)	Specific power and power density functions based on curvefits of data from four existing engines over a broad power range	When extrapolated, shape of trendlines mirrors proprietary data from Barber-Nichols, Inc. although ARL data appears quite conservative. BNI data may not include some components that are part of ARL package (Lowe, 2005).
Turbine Wheel	Tool developed to plot specific speed / specific diameter on nondimensional $Ns / Ds$ chart to predict efficiencies.	
Turbine + Housing Gearbox Regenerator	Power density functions based on curvefits of data for specific components, with volumes taken from prints.	
PEM Fuel Cell Systems Cell Stacks	Literature review and analysis of published data (Klanchar, 2004).	
Combustor Systems	Performed CFD analysis on modular combustor design and verified performance over a wide range of power levels, with various fuel / oxidizer combinations (Cor, 2004, Cor, 2005).	By demonstrating that a "generic" combustor is capable of operating over a range of powers likely to be encountered in hybrid torpedo operation, we can use a single compact combustor design for a wide range of preliminary system sizing analyses. Systems requiring additional power can be assembled from multiple combustor cans operating in parallel.
Tankage for High Pressure Gases	Adapted commercial design tool for systems consisting of cylindrical pressure vessels with semi-elliptical heads. Curvefits to COTS component data	Likely to be somewhat conservative.
Electric Motors Motor Controllers		
Fuel and seawater pumps	Typically, size and weight of existing components or current COTS articles are scaled in proportion to power.	
Heat Exchangers Gas – Gas	Compact recuperator design tool developed at ARL run for a range of cases.	
Gas – Liquid	Use recuperator scaling rules or fit to COTS data.	

#### 4. DETAILED HYBRID TORPEDO TRADE STUDY

A separately funded Phase I STTR program involved the creation of a framework in which a large number of alternative hybrid torpedo powerplants were compared. The results of this Phase I study are presented in more detail in the final report (Barber-Nichols, Inc., 2006). Most of the subcomponent models used in this STTR trade study were developed under ONR funding under the ongoing "Hybrid Torpedo Concept Development" program.

The STTR trade study was modified slightly, with several improved subcomponent models and more detail added in certain areas. The relationship between the STTR and the "Hybrid Torpedo Concept Development" programs was therefore completely synergistic in that much of the work performed for the STTR study was leveraged for the study discussed below.

Appendix A of this document is based on portions of the Phase I STTR final report and contains much more detail about the assumptions used in assembling the trade study model.

##### 4.1 Overview of Study Parameters

A hybrid torpedo consists of a fuel / oxidizer combination (or, potentially, a monopropellant) along with both low and high power conversion systems. Figure 7, below, shows the various subcomponents considered for this study.

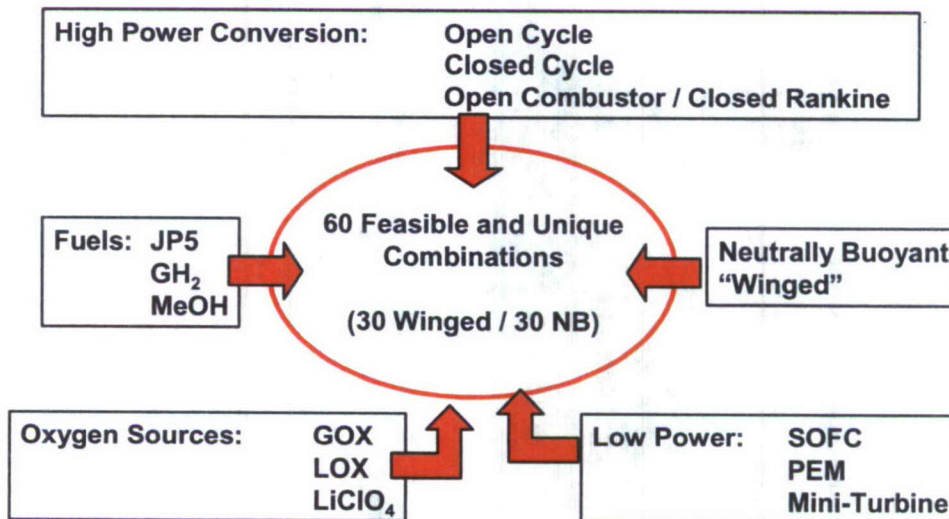

Figure 7: Fuels, Oxidizers and High / Low Power Conversion Systems Considered for Trade Study

As discussed in more detail in Appendix A, two buoyancy criteria were applied. For the first set of analyses, the vehicle was constrained to be neutrally buoyant. A second set of calculations was performed with the assumption that some lift-generating mechanism would be provided, allowing a negatively buoyant vehicle to fly at very low speeds. Although referred to generically as "winged" vehicles, this latter class of hybrid torpedoes might incorporate autogyro rotors, vectored thrusters, an inflatable buoyancy bladder or some other mechanism of producing lift at low speed.

As shown in Figure 7, various combinations of three candidate fuels, three oxidizers, three low-power conversion systems and three high power conversion systems add up to 30 viable systems for each of the buoyancy criteria, for a total of 60 candidates. This total reflects the fact that non-viable combinations (such as a PEM fuel cell with JP-5 fuel) were eliminated from the list. Each viable combination of fuels, oxidizers and conversion system was assigned a number from 1 to 30, with calculations performed for both neutrally buoyant and "winged" configurations considered for each.

#### 4.2 Summary of Trade Study Conclusions

A detailed analysis of the results of the trade study is presented in Appendix A. In summary, the trade study identified three key enabling technologies that govern the endurance of a hybrid torpedo. First, a dense oxygen source is critical. Since the amount of oxidizer that needs to be carried generally has a volume many times that of the fuel, increased oxygen storage density has a disproportionate effect on torpedo performance.

Second, if solid oxide fuel cells live up to their promised efficiency the savings in fuel and oxidant more than compensate for the increased size and complexity of this system relative to other alternatives such as miniturbines.

Finally, the use of buoyancy enhancing features such as wings, inflatable or morphing bladders, autogyro rotors etc. has a strong potential influence on the range of a hybrid torpedo. The increase in range associated with the extra fuel and oxidant that can be carried more than offsets the weight, volume and added drag associated with these features. This is particularly true if a dense but heavy oxidant source such as lithium perchlorate is used.

### 5. BUOYANCY CONSIDERATIONS

As discussed above, one of the conclusions of the trade study was that a mechanism to allowing a negatively buoyant vehicle to fly through the water at low speed would have a significant impact on range. This effect is illustrated for a number of fuel/oxidizer pairs (as well as representative battery systems and the monopropellant Otto II) in Figure 8, below.

Figure 8 is a specific energy / energy density chart for a range of energy sources. The values plotted on this chart represent shaft work specific energies / energy densities, i.e., the efficiencies of the engine or other energy conversion system are taken into account. For each fuel / oxidizer pair (or other energy source) both "low" and "high" pairs are plotted, indicating different assumptions for energy conversion. For example, the "high" value for JP5-O<sub>2</sub> represents an open combustor / closed cycle Rankine system such as the one shown in Figure 5, with a 70% efficient turbine. The "low" value is an open cycle system operating at a backpressure of 250 psi, with a less efficient turbine. For batteries, the "high" point is a cell with an energy density of 1000 watt-hr/liter and a physical density of 2.5 gm/cm<sup>3</sup> and the "low" battery reflects an 80 watt-hr/kg NiMH system with a similar physical density, both assumed to drive a 90% efficient motor/controller pair.

The ratio of the specific energy to the energy density of a given fuel / oxidizer combination is its specific volume (the inverse of the specific gravity). Several lines of constant specific gravity are shown on the plot, including the one corresponding to seawater (assumed to have a density of

1.03 gm/cm<sup>3</sup>). Note that the “high” and “low” points for any given fuel/oxidizer combination lie along a line that corresponds to the appropriate specific gravity of the chemical constituents.

In order to achieve an overall neutrally buoyant system it is necessary to provide buoyancy volume elsewhere in the system to accommodate fuel/oxidizer pairs that are denser than seawater (i.e. that lie below the red line of Figure 8). In practice, it is necessary to account for the weight and volume of every component of the system. For example, in the trade study discussed above and in Appendix A, the volume associated with inefficient packing of propulsion system components provided some buoyancy to offset the mass of fuel and oxidizer.

A dramatic oversimplification is realized by assuming that everything in the vehicle except the expendable materials is neutrally buoyant. This is a reasonably good assumption in many cases, and becomes less crucial as the fraction of vehicle volume allocated to reactant storage becomes dominant, which is the case for UUVs.

In the limit, the maximum energy density achievable by a given fuel/oxidizer pair is that which corresponds to the location along the neutral buoyancy line with the appropriate specific energy. This is illustrated in Figure 8 for the “JP5-Chemical Oxygen Storage” and “Batteries” cases. Both of these systems are penalized significantly by the need to provide additional buoyancy to compensate for their high densities, although the batteries suffer to a proportionally greater extent.

Therefore, the need for a mechanism to allow a negatively buoyant vehicle to operate at extremely slow speeds is crucial in order to take advantage of systems with physically dense reactants. This includes battery systems as well as thermal powerplants that rely on dense chemical oxygen sources.

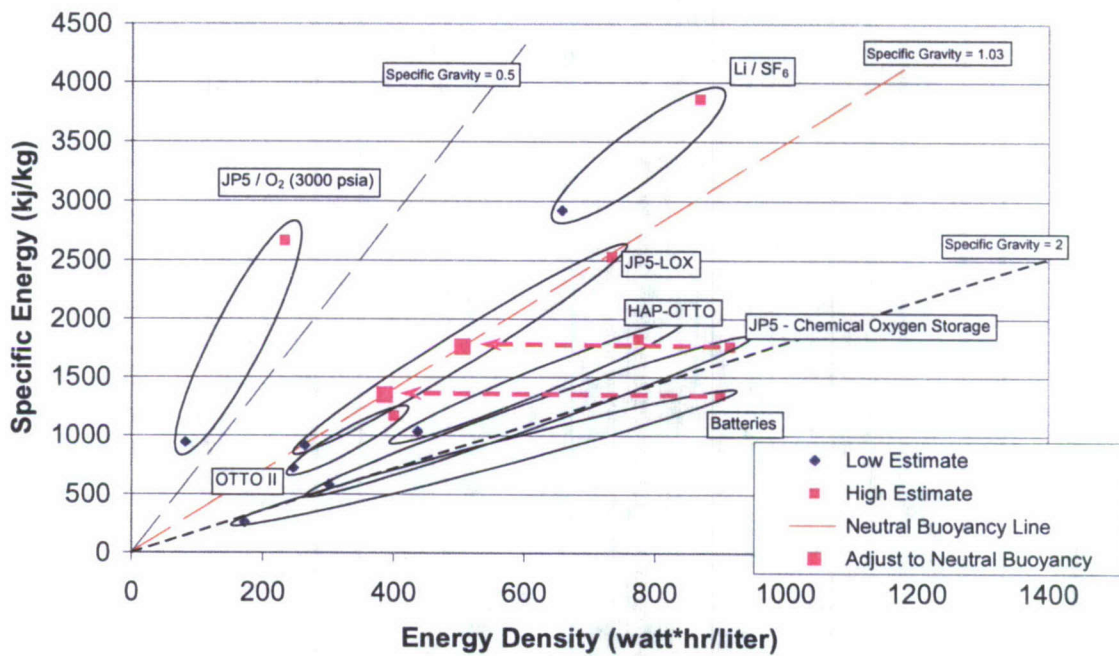

Figure 8: Buoyancy and Effective Energy Density

## 6. HYDRODYNAMIC STUDIES

As discussed above, the trade study conducted as part of the FY'06 Hybrid Concept Development program focused largely on the impact of various energy systems on vehicle range. A very simplistic hydrodynamic performance assumption, i.e. a constant lift to drag ratio, was applied for this study. This is not a rigorously valid assumption due to the significant effect of Reynolds number on skin friction drag over the speed range.

Since this simplified model identified the use of a wing (or other mechanism for enabling non-neutrally buoyant flight at very low speeds) as a key enabling technology for implementation of hybrid-powered underwater weapons and vehicles, a more detailed hydrodynamic study was undertaken near the end of FY '06. This study was performed by Mr. Steven Willits, and continued into FY '07. A forthcoming memorandum will discuss the FY '07 work.

For energy systems that produced a negatively buoyant vehicle, the concept of a large main wing on the vehicle was analyzed. A main wing concept was chosen because it is usually an efficient means of generating lift to offset the negative buoyancy of the vehicle such that level flight can be achieved. The penalty for using a wing to generate lift is the added drag (i.e. added power required) to maintain flight at a given speed.

Figure 9 shows the main component drag contributions for a notional "winged" torpedo and Figure 10 shows the net lift-to-drag ratio of the vehicle. At very low speed, the wing must



operate at relatively high lift coefficients ( $C_L = 1.6$  in this case) and the primary contribution to drag will be the induced drag from the wing. In this example, at 5 knots, the wing drag is about five times (5X) the drag on the rest of the vehicle. At some higher speed, 7 knots, the required wing lift coefficient drops ( $C_L = 0.8$  in this case), and the wing drag contribution also drops to a level equal to the contribution from the rest of the vehicle. The result is such that the net drag is a global minimum relative to the entire speed range (see Figure 9) and the lift-to-drag ratio for the vehicle is a global maximum (see Figure 10). Figure 11 shows the equivalent horsepower (EHP) required to maintain a given speed, with minimum power being achieved at a speed of 5 knots. The maximum lift-to-drag speed (7 knots) and the minimum power speed (5 knots) have significant meaning. Maximum range (distance traveled) is achieved at maximum lift-to-drag (7 knots), while maximum endurance (loiter time) is achieved at minimum power (5 knots). At speeds above maximum lift-to-drag, the viscous forces begin to dominate the overall drag on the vehicle and both range and endurance will be reduced accordingly. It is clear from Figures 9 and 11 that the viscous drag produced by the wing at high speed nearly doubles the power required to maintain a constant speed and depth. Thus, although a main wing system on a torpedo is an efficient way to generate the lift required to maintain constant-depth flight of highly negatively buoyant vehicles, the wing drag produced at high speeds becomes relatively large.

The methods used for the hydrodynamic analysis results presented herein are more complete, and realistic, than the simple assumptions made in previous energy-system studies. For future studies, we will use the current analysis methods and build upon them to include additional considerations.

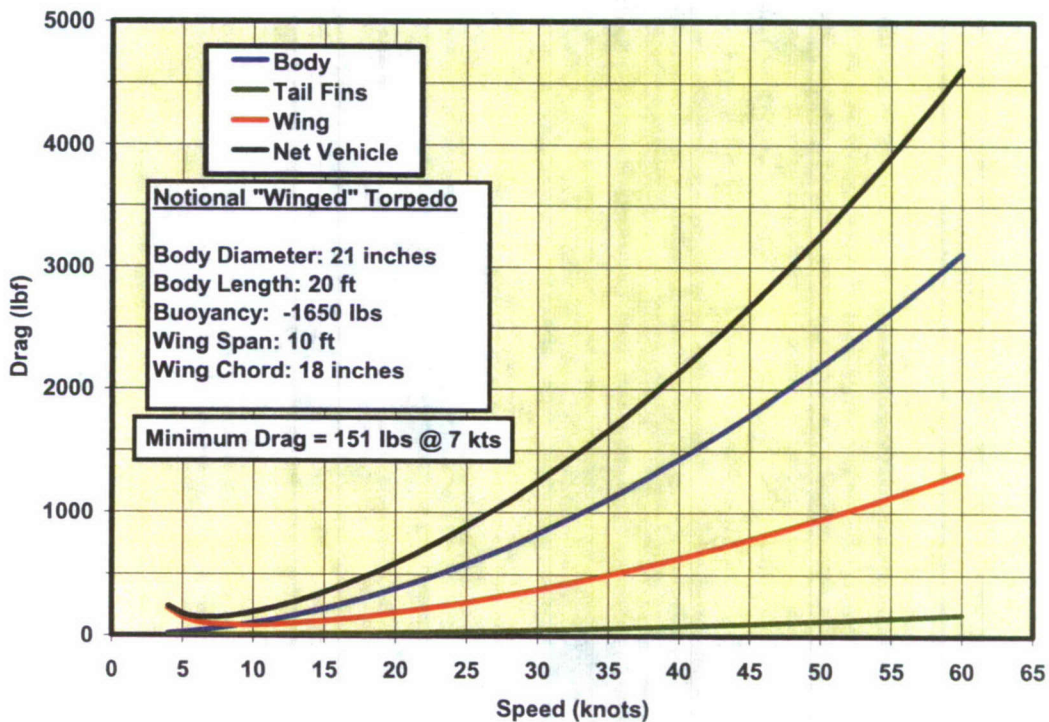

Figure 9: Component Drag Contributions and Net Drag of a Notional "Winged" Torpedo

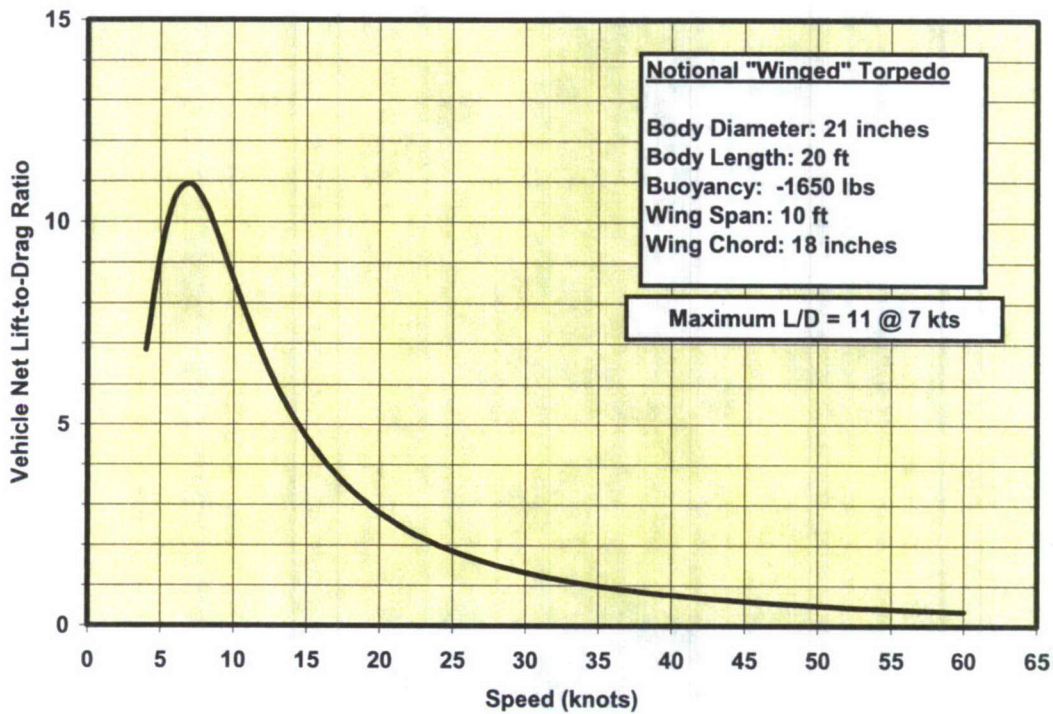

Figure 10: Lift-to-Drag Ratio of a Notional "Winged" Torpedo

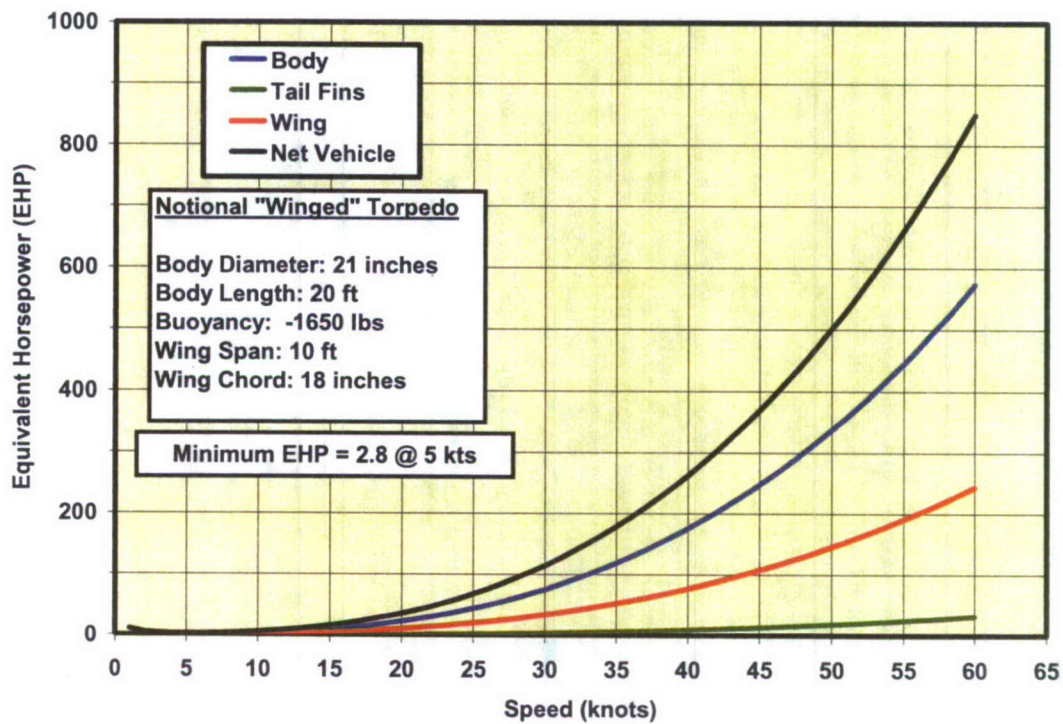

Figure 11: Power Required of a Notional "Winged" Torpedo

## 7. SUMMARY

As outlined above, this multi-year effort began as a first-principles analysis, with the mission parameters that affect hybrid torpedo performance cast in non-dimensional forms. As the program progressed, thermodynamic data was collected to predict the performance of various fuel / oxidizer combinations (or monopropellants), and eventually component models to predict the performance, size and weight of various energy conversion systems were developed.

This data allowed specific hybrid torpedo configurations to be evaluated in a trade study, outlined in detail in Appendix A, which built on work originally performed as part of a Phase I STTR program. The most important conclusion of this trade study, which is also discussed in more detail in Section 5, above, is that a means of propelling a non-neutrally buoyant vehicle (torpedo or weaponized UUV) at very low speeds is crucial to obtaining the large increase in range that go along with energy dense energy sources and power dense conversion systems such as advanced batteries, fuel cells, and chemical oxygen generators.

As with essentially all electromechanical systems, the performance of a weapon is highly dependent on the mission it is called upon to perform. One of the advantages of hybrid systems (either hybrid torpedoes or weaponized UUVs) is that they can be optimized to perform a range of missions more effectively than conventional weapons, but it is still necessary to consider the way in which a weapon is likely to be employed in order to arrive at an optimal design. The impact of operational parameters on hybrid torpedoes can be seen in both the nondimensional analyses (Figures 3 and 4) and in the results of the trade study (Appendix A).

## 8. FUTURE PLANS

In the near term, the hydrodynamic study outlined in Section 6 will be extended to more specifically address various aspects of hydrodynamic performance, including thrust production, steering and maneuvering, and the use of lift-producing devices for negatively buoyant vehicle concepts. Novel concepts for lift producing devices will be evaluated.

A new trade study will be conducted, building on the one outlined above. Updated component models will be considered as will alternative energy storage and energy conversion technologies. The results of the hydrodynamic study (Item 1) will be used to provide a more realistic estimate of the effects of "winged" flight of a non-neutrally buoyant torpedo.

The THERMHYB program has been significantly expanded since it was originally created in FY '03. A TM describing the operation of this tool will be drafted.

As discussed above, development of an optimal hybrid torpedo or weaponized UUV design requires insight into the mix of missions that the hybrid weapon will be called upon to perform. In the future it is hoped that this ongoing analysis will become more tightly integrated into CONOPS studies so that the impact of hybrid torpedoes / weaponized UUVs can be more accurately assessed.

## REFERENCES

Barber Nichols, Inc., "Hybrid Propulsion Systems for Undersea Weapons," Phase I STTR Final Report, Topic N05-T024, Contract Number: N00014-05-M-0182. February 6, 2006

Chase, M. W. et. al., JANAF Thermochemical Tables, Third ed., (Washington, U. S. Department of Commerce), 1986.

Cor, Joseph J., Summary of FY04 Modeling of Hybrid Combustor System, (ARL Internal Memorandum IM04-096), 1 Nov 2004.

Cor, Joseph J., "Summary of Task 1 Hybrid Combustor Modeling Effort," (Appendix A of final report, contract N00014-00-G-00580080).

Herr, John J., "Comparison of Open vs. Closed Rankine Cycle Underwater Power systems that Combust a Hydrocarbon Fuel with Oxygen" (Unpublished ARL / PSU Interoffice Correspondence), February 28, 2002.

Lowe, David, (Barber-Nichols, Inc.), Personal communication with author, 2005.

Peters, J. A., THERMHYB Computer Program (ARL / PSU Internal Memorandum 03-058), April 30, 2003.

Roberts, R. W., (NUWC-NPT), Personal communications with author throughout 2006.

## **APPENDIX A: DETAILED DESCRIPTION OF HYBRID TORPEDO TRADE STUDY**

### **A.1 INTRODUCTION**

As discussed in the body of this report the Applied Research Laboratory participated in a Phase I STTR program (contract number N00014-05-M-0182) that included a detailed study of hypothetical hybrid torpedo configurations. This study leveraged the tools developed under previous ONR funding.

At the conclusion of the STTR program, the model used for this study was updated to incorporate additional data including an updated motor sizing model provided by NUWC-NPT (Roberts, 2006), as well as several other improved component models. This Appendix presents the results of this expanded trade study and contains a detailed description of the alternative configurations evaluated in this effort, as well as results and conclusions.

This updated modeling work was performed as part of the FY '06 "Hybrid Torpedo Concept Development" program. The program was sponsored by the Office of Naval Research (contract N00014-05-G-0106/0017), Kam Ng., program manager.

### **A.2 HYBRID SYSTEM COMPONENTS AND COMPONENT MODELS FOR SBD TRADE STUDIES**

A hybrid torpedo consists of a collection of subsystems, including the warhead, propulsor, guidance and control system, etc. this effort specifically focused on the analysis of hybrid propulsion systems, which can be generically categorized as a combination of a fuel, an oxidizer, and high power and low power energy conversion subsystems.

The following sections describe a model developed at ARL to evaluate a range of candidate hybrid torpedo propulsion system configurations. Later sections discuss the results of trade studies performed with this model and give suggestions for future research based on the results of these analyses.

#### **A.2.1 Overall Vehicle**

For the purpose of this study, the weapon was assumed to be the size of an existing heavyweight torpedo, as shown in Figure A1 which approximates the dimensions of typical weapons. It was assumed that the entire fuel tank section and 70% of the tailcone section would be available for propulsion system components and fuel / oxidizer storage. The remainder of the tailcone volume is assumed to be devoted to propulsor bearings, fin actuators, etc.

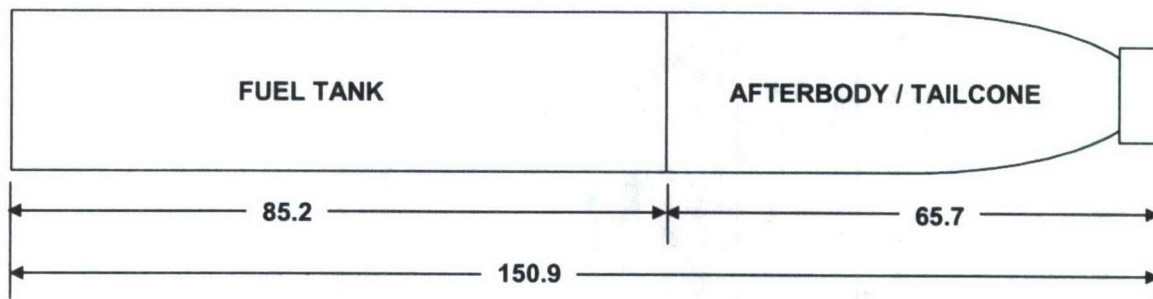

**Figure A1: Size of Heavyweight Torpedo Assumed for Trade Studies**

Data on the internal and external contours of the Mk. 48 torpedo were obtained from ARL's water tunnel. From this information, an available internal volume of 39,950 cubic inches was calculated. A displacement of 1650 pounds of seawater was estimated from the external volume of the corresponding section of the torpedo. For neutrally buoyant systems, this represents the maximum weight of the fuel, oxidizer, propulsion system components and shell.

A shell section weight of approximately 430 pounds was estimated by multiplying the difference between the external and internal volumes of the vehicle by the density of a typical aluminum alloy.

For this study, the sponsor selected a low speed of 5 kt (2.57 m/sec or 5.75 statute miles/hour) and a high speed of 60 kt (30.9 m/sec or 69.0 statute miles/hour). Estimates of propulsion energy requirements were made after consulting ARL and NUWC (Roberts, 2006) metrics.

A hotel power of 6 hp (4.47 kW) was selected, also based on experience with existing systems.

Mechanical components, including the high and low power conversion systems, were assumed to pack with 2/3 efficiency. In other words, a pump that has an overall volume of 100 cubic inches is assumed to impose a 150 cubic inch penalty on the volume of the system. Fuels and oxidizers were assumed to pack with perfect efficiency, although appropriate space and weight allocations for the fuel and oxidant tanks and /or chemical oxygen generator systems were applied.

### **A.2.2 Fuels**

For this study, three candidate fuels (JP-5, compressed hydrogen gas, and liquid methanol) were evaluated.

JP-5 was used because it is fairly representative of a range of liquid hydrocarbon fuels that are available through the current Navy logistics chain. JP-5 is used as a propulsion fuel for Navy aircraft as well as gas turbine powered ships (DDGs, FFGs, etc.).

It should be recognized that for the purpose of this study, JP-5 is a proxy for a wide range of fuels including Diesel Fuel Marine, low-sulfur diesel fuel, JP-8, Jet-A, etc. All of these fuels have roughly the same specific energy and specific gravity, so selection of one over another would have relatively minor effects on the overall performance of a hybrid torpedo system. The choice of fuel does impact significantly on some components, particularly fuel processors for use with

solid oxide fuel cells. A fuel processor designed to reform JP-5 might look very different from one to handle pure kerosene, but these differences would have minor impacts on the overall performance of the hybrid weapon.

Compressed hydrogen gas (designated GH2 in sections that follow) was chosen as a candidate fuel for this study because it uniquely allows the use of PEM fuel cells for low power and "Closed Cycle Rankine" systems for high power operation. These conversion systems will be discussed in later sections of this document.

Finally, methanol (MeOH) was chosen because it was originally planned for Fuel Cell Energy to evaluate a methanol-based fuel cell system. It was anticipated that the lower specific energy associated with methanol might, in some cases, be offset by a reduction in the complexity of the fuel cell system. Although no MeOH fuel cell model was produced in time for inclusion in this analysis, this fuel was left in the study. As will be discussed below, methanol was shown (counterintuitively) to outperform JP-5 in some cases.

### A.2.3 Oxidizers

With the exception of monopropellant formulations such as Otto Fuel II (which was not included in this study), all fuels require an oxidizer to burn.

For torpedo applications, the selection of an oxidizer is crucial because the volume of the oxidizer can be many times that of the fuel. Recall that the combustion of the logistics fuel JP-5 and oxygen gas which can be approximated by the chemical equation:



If the oxygen is carried as a compressed gas at 3000 psi pressure, over ten times as much volume must be devoted to oxygen storage as to fuel.

Most commercial uses of pure oxygen rely on storage as a moderate pressure (i.e. 2400 psi) gas or as a cryogenic liquid. Figure A2 illustrates the relative oxygen density of various chemical and physical storage mechanisms.

## Chemical Oxygen Source Storage Densities

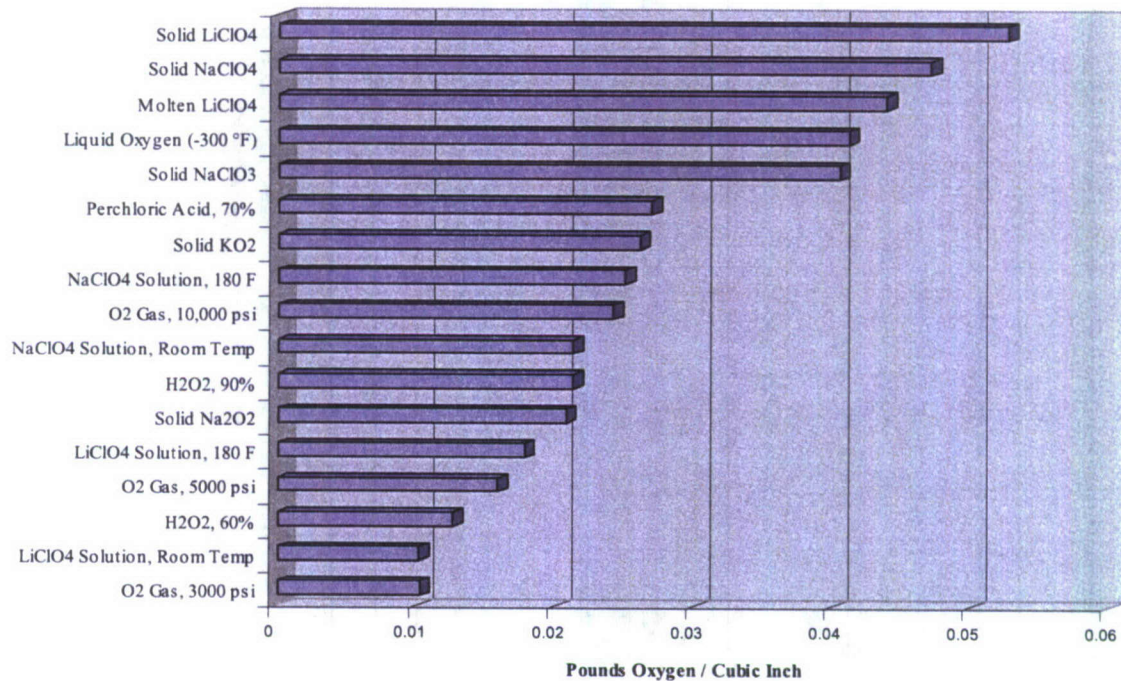

**Figure A2: Candidate Oxygen Storage Media**

### A.2.3.1 3000 PSI Gaseous Oxygen (GOX)

Because its use is so widespread, gaseous oxygen storage (GOX) was selected as one candidate oxidizer for this hybrid torpedo trade study. As shown in Figure A.2, the choice of storage pressure affects the density of GOX storage. Since oxygen behaves approximately as an ideal gas under most conditions, doubling the storage pressure from 3000 psi to 6000 psi essentially doubles its density.

The use of very high pressure oxygen imposes significant safety concerns. Normal industrial safeguards designed for safe operation of systems containing widely available 2400 psi oxygen do not adequately address the safety issues associated with oxygen gas stored at significantly higher pressures.

While the storage density of oxygen gas increases with increasing pressure, the range of a hybrid torpedo that uses this oxidizer does not necessarily increase in proportion. The increased weight and volume of the oxygen tank required to withstand higher pressures can significantly reduce the amount of fuel that can be carried, particularly for neutrally buoyant systems. Figure A3, below, shows results taken from the trade study that will be discussed in more detail in a later section. This figure shows the low-speed ranges of neutrally buoyant hybrid torpedo systems that utilize compressed O<sub>2</sub> (GOX) storage as functions of oxygen storage pressure.



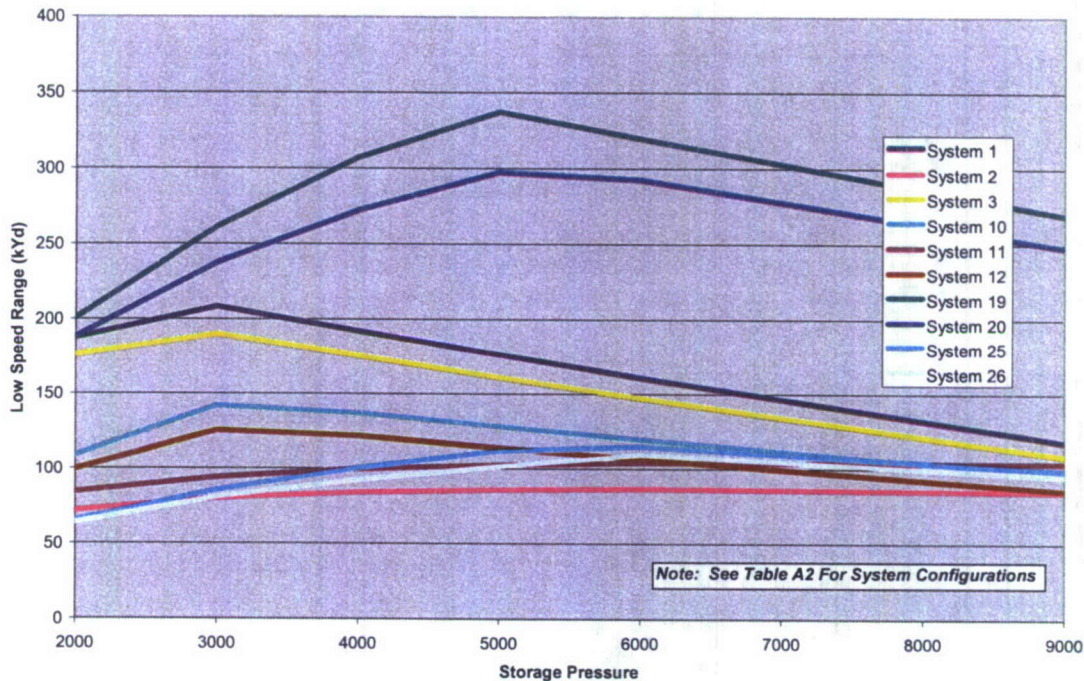

**Figure A3: Low Speed Range of Neutrally Buoyant GOX-Based Systems**

Each candidate system has an optimal storage pressure, ranging from 3000 psi to 6000 psi. In all cases, the impact of increased oxygen pressure is relatively small. For example, the most dramatic effect of increased oxygen pressure is seen in the range of system #19 (which uses JP-5 fuel and consists of a solid oxide fuel cell for low power and an open cycle combustor for high power). In this case, increasing the oxygen storage pressure from 3000 to 5000 psi only increases the range by 29%.

In light of the relatively limited effect of increased pressure and because of the safety concerns outlined above, only 3000 psi GOX was considered for the trade study. Since (as will be shown in the later discussion) the performance of the GOX based systems is considerably lower than that of other alternatives, the use of higher oxygen storage pressures would not improve their performance enough to affect the overall conclusions of this study.

A significant concern that was not addressed in this study is the fact that only a fraction of the oxygen gas stored in a tank is available if it is to be consumed in a conversion system that operates at high pressures. For example, a 3000 psi oxygen tank feeding a 1000 psi combustor can only deliver oxygen until its pressure falls to match that of the combustor. Since oxygen is essentially an ideal gas, its density is proportional to pressure, so in this case only 2/3 of the oxygen could actually be utilized unless a compressor were used to raise the pressure of the remaining gas. Use of a compressor would be an energy, volume and weight intensive proposition.

While it is easy to predict this effect, it is difficult to adequately account for it when comparing different propulsion system configuration, because it is possible for the high and low power conversion systems to require different oxygen pressures. For example, a PEM cell may operate with very low oxygen pressures, so nearly all of the oxygen would be available for low-power operation even if only 2/3 could be used to burn fuel and drive a turbine at high power. The situation is complicated by the fact that after a period of operation, this weapon could have tens or hundreds of kiloyards of range left at low speed yet be unable to execute even a very short high speed burst. For systems in which the operating pressure of the combustor or fuel cell varies with depth, it becomes even more complicated to compare the performance of alternative systems.

As discussed above, the behavior of GOX-based systems is generally relatively poor compared to other alternatives even if conversion system pressure effects are ignored. For this reason, no attempt was made to account for this degradation in performance for the purpose of this study.

The same concern and conclusion applies to the gaseous H<sub>2</sub> fuel.

#### A.2.3.2 Liquid Oxygen (LOX)

Liquid oxygen is used widely in commercial and medical applications. As shown in Figure A32, it has a very respectable oxygen storage density; about four times as much oxygen is available from a given volume of LOX than the equivalent volume of 3000 psi GOX.

LOX is a cryogenic liquid and must be handled with extreme care, but established safety protocols allow its use throughout many industries. It is not clear whether LOX is currently used in any deployed weapons systems, or if the special safety and handling requirements of weapons would prohibit its use. Liquid oxygen is present on certain Navy fleet units such as hospital ships. In addition, some air independent diesel propulsion systems in use by foreign navies use liquid oxygen.

LOX systems typically operate at low pressure so it might be necessary to pump it to combustor inlet conditions. There are a number of LOX pumps that are commercially available, unfortunately most require that a portion of the cryogenic liquid be allowed to vaporize in order to maintain pump temperatures. It is not clear whether this could be achieved in the torpedo application. It is also possible to configure a LOX tank to withstand any desired oxygen delivery pressure, although this would result in a heavier system.

For the purpose of this study, the LOX tank is assumed to operate at low pressures, and no space or weight is allocated to a LOX pump. These optimistic assumptions imply that a suitable pump could be found and that its impact on system performance would be relatively small.

The biggest drawback of LOX from a weapons standpoint is its limited shelf life. At normal atmospheric pressure, LOX boils at a temperature of 90 K (-297 °F). For this reason, LOX tanks must be vented to allow gas to boil off or else some means of topping off and/or continuously cooling the oxygen tank must be provided. From a hybrid torpedo standpoint, this means that the performance of the weapon will gradually diminish over time unless measures are taken to actively cool or add LOX to each weapon. The shipboard and shipyard infrastructure necessary for this task is significant and may represent an absolute barrier to the use of LOX in weapons.

LOX may be a better choice for UUVs, and there have been some studies of the use of LOX in heavyweight torpedo-sized vehicles (Haberbusch, et. al., 2002). For this reason, LOX was included in this study despite its potential drawbacks.

### A.2.3.3 Chemical Oxygen Storage

As shown in Figure A.2, there are a wide range of oxygen containing chemicals that could potentially be used to produce oxygen on demand.

Hydrogen Peroxide, or  $H_2O_2$ , has been used as a torpedo oxidant in the past, but it has some of the same safety, shelf life and handling issues as LOX. Recently, the sinking of the Russian submarine Kursk appears to be the result of a failure of a peroxide based weapon. Since  $H_2O_2$  has a lower oxygen storage density than LOX, it was not considered for this study. Potassium superoxide ( $KO_2$ ) and sodium peroxide ( $Na_2O_2$ ) produce oxygen through simple reactions with water, but this technology has not been demonstrated at any significant power level. These oxidizers do not have a particularly high oxygen storage density, so they were not considered in this study.

Most of ARL's chemical oxygen generator efforts have focused on the use of lithium perchlorate, for several reasons;

1. As shown in Figure A32,  $LiClO_4$  has the highest oxygen storage density of any known chemical oxygen source.
2.  $LiClO_4$  is unique among chlorates and perchlorates in that it has a relatively stable liquid phase. This allows the material to be handled in a molten state, potentially allowing solid blocks to be cast in any required shape for insertion into a weapon or UUV during refueling.

ARL has developed a "Steady Flow Oxygen Generator" in which molten  $LiClO_4$  is controllably decomposed to form lithium chloride and oxygen via the reaction;



In the existing design, the entire mass of lithium perchlorate is melted at the beginning of the mission and pumped (usually hydrostatically) from a relatively cool (600 °F) storage vessel to a hotter (1200 °F) reaction vessel where it decomposes essentially instantaneously. By varying the flow rate of molten perchlorate, the rate of oxygen production can be controlled.

This technology is not directly applicable to hybrid torpedo (or, by extension UUV) missions for several reasons;

1. While 600 °F molten perchlorate is relatively stable, over time it begins to decompose. Since the decomposition reaction is catalyzed by the chloride product, the rate of decomposition increases over time, eventually becoming violent. For this reason, long duration missions are not feasible.
2. The hot storage vessel and reaction vessel components lose heat to their surroundings over time, so energy must be added to the system. Since the storage vessel can be very

massive, this heat loss represents a significant drain on the overall efficiency of the propulsion system. This concern is less for a reaction vessel, which is typically smaller and far less massive.

3. In developmental configurations, the reaction vessel component is sized to contain the entire load of LiCl product. While this was acceptable for the high power / short duration mission for which the molten perchlorate generator was developed, it is not practical for a long duration mission in that the reaction vessel would become very large.

Attempts to remove the chloride from the reaction vessel during operation have been hampered by the tendency of this material to freeze and solidify as it is withdrawn from the reactor.

A previous Phase I STTR program performed by Barber Nichols, Inc. and ARL (ONR STTR Topic N01-T005) attempted to address some of these issues through catalytic enhancement of the decomposition process. While this earlier program was partially successful, it did not address some of the more significant issues surrounding the use of LiClO<sub>4</sub> in a long-duration low power system such as a hybrid torpedo or a UUV.

Note that this discussion assumes that pure oxygen gas is a desired intermediate product in a hybrid propulsion system. For fuel cell based systems, pure O<sub>2</sub> is certainly required. In some cases, however, it may be more effective to combine the LiClO<sub>4</sub> directly with fuel in a specialized combustor.

A previous study at ARL investigated the use of LiClO<sub>4</sub> in aqueous solution. In a weapon, a block of perchlorate would be gradually dissolved in seawater and sprayed into a combustor to react with fuel. Some limited testing was performed to demonstrate the temperature and pressure dependence of the formation of oxygen from aqueous solution. As discussed in the body of this report, CFD studies have shown that a combustor could be configured to accept an aqueous perchlorate solution as an oxidizer with minimal volume penalties.

An alternative approach would be to use a powder feed system of some kind to feed pure solid or molten perchlorate directly into a combustor, where it would dissociate and react with the fuel.

In either approach, it would be necessary to separate the chloride product from the high temperature gas stream, and to configure the combustor to avoid plugging with lithium chloride "slag." This problem is similar to that being addressed in ARL's DARPA-funded Hybrid Aluminum Combustor program. Many of the analytical tools and technologies used to prevent alumina from choking this combustor could be applied to develop a system that would allow perchlorate to be consumed directly in a combustor without the need for intermediate oxygen production.

For hybrid torpedoes that use combustion-based low power systems (i.e. the Mini Turbine systems discussed below), this type of combustor could serve both the high and low power conversion systems. For weapons that incorporate fuel cells, it would be necessary to provide a chemical oxygen generator to operate at low rates even if a direct perchlorate fed combustor were used at high power.

A lithium perchlorate oxygen source was included in the current system trade study. Assumptions regarding the weight and volume of the oxygen generator component are discussed below.

#### A.2.3.4 Oxidant and Fuel Storage Subsystems

For the liquid fuels (methanol and JP-5) a 10% volume and weight penalty was imposed to account for the tank, including internal baffling and mounting hardware.

For high pressure hydrogen and oxygen storage, a cylindrical pressure vessel with flanged and dished heads was assumed. The outside diameter of this vessel is assumed to correspond to that of the torpedo, so the pressure vessel forms a section of the weapon's shell.

For this model, these tanks were assumed to be made from aluminum with an allowable design stress of 45,000 psi and a density of 0.1 pounds/cubic inch. A head design spreadsheet (Pressure Vessel Engineers, Inc., 2005) was used to generate a lookup table of head weights, internal head volume and head length as a function of internal pressure. Interpolation between the data on this table allowed sizing of H<sub>2</sub> and GOX tanks. The stress in the cylindrical wall sections of the tanks was assumed to be purely tangential, a slight approximation that is appropriate given the very reasonable design stress level used in this analysis.

Allowance was made for the volume of a 2" OD hollow tie-rod, which can be used to pass electrical signals and power, fuel lines, etc. through the GOX and GH<sub>2</sub> tanks. Although this tie rod would be a structural member in an optimized design, for this analysis it was not assumed to contribute to the strength of the pressure vessel.

There is no current lithium perchlorate based oxygen generator design that can be used in a hybrid torpedo application. For this study, rough approximations to this system's constituent weights and volumes were made to arrive at an estimated system weight of 313 pounds and a volume of 4916 cubic inches. As with other mechanical components (i.e. the conversion systems) a volume penalty of 150% was applied to account for packaging. It is assumed that this volume and weight would be representative of both types of perchlorate-based systems discussed above (i.e. direct feed of LiClO<sub>4</sub> to combustion systems or intermediate production of oxygen gas for use with fuel cells).

The selection of a representative size for a chemical oxygen generator is one of the most uncertain aspects of this study. To evaluate the effects of this uncertainty, a series of analyses were made in which the basic oxygen generator size and weight discussed above was varied. While the volume and weight of the generator was found to have a very significant effect on overall system range, the conclusions of this study regarding the relative benefits of a chemical oxygen source (see discussion in a later section) were unchanged even if the weights and volumes of the generator were doubled.

### A.3 HIGH POWER ENERGY CONVERSION SYSTEMS

This section describes the three high power propulsion systems investigated for this effort. In each case, the engine is made up of a number of subcomponent models which are discussed in more detail in a later section.

### **A.3.1 Open Cycle Engine (OC)**

The open cycle engine operates in a manner similar to the current Torpedo Mk. 48 propulsion system, in that fuel and oxidizer are burned in a high pressure combustion chamber, with the resulting products passing through an expander engine before being exhausted to the surroundings.

Because the expander engine exhaust pressure varies with depth, this type of system is less efficient at greater depths.

For the purpose of this analysis, it was assumed that the expander engine used in this application is a turbine and gearbox, rather than a swashplate piston engine as in the current Torpedo Mk. 48. This results in a somewhat more compact and lighter energy conversion system.

The THERMHYB mixed gas expander module was used to predict energy conversion efficiency. An expander engine isentropic efficiency of 47% was applied. While this is somewhat lower than the efficiency one would expect from a turbine engine it recognizes the fact that it is difficult to produce an efficient engine that operates at a high backpressure. This particular value was chosen because it was used in a study of various bipropellant combinations that was reported by P. Dunn of NUWC (date unknown) which was in turn used to validate the THERMHYB expander module. Also in keeping with Dunn's data, an engine inlet temperature of 2400 °F and pressure of 5000 psi was assumed.

At a 1000' operating depth, the resulting overall thermodynamic efficiency of this energy conversion system was found to range from 14 to 16% (the actual value is dependent on the fuel / oxidizer combination, as the composition of the products affects the energy that can be extracted from the exhaust gas stream).

### **A.3.2 Semi Closed Cycle Rankine (CCR)**

This system uses a combustor to burn hydrogen gas with oxygen. A spray of liquid water is used as a diluent to reduce peak temperatures. The resulting steam passes through a turbine, is cooled and condensed before being pumped back through the combustor. Because excess water is produced as the H<sub>2</sub> and O<sub>2</sub> are consumed, it is necessary to pump a small amount of liquid overboard. The THERMHYB steam turbine module accounts for the small amount of energy required for this operation. A turbine efficiency of 65% was assumed for this system.

Because of the high peak temperatures, the thermodynamic efficiency of this system (relative to the lower heating value of the fuel / oxidant combinations) is relatively high, ranging from 30 – 36%.

### **A.3.3 Open Combustor Closed Cycle Rankine**

A third high power energy conversion system investigated for this study is shown schematically in Figure 5 in the body of this report. This was taken from an earlier unpublished study performed by J. D. Herr of ARL. Herr showed that under some circumstances, this propulsion system outperformed open cycle engines by a significant margin, potentially offsetting its increased complexity.

In this device, fuel and oxidant are burned in a combustor. The hot products are passed through a steam generator then dumped overboard. The steam produced in the steam generator drives a conventional regenerated Rankine cycle.

The THERMHYB program was again used to predict the performance of this system for various fuel and oxidizer combinations. Overall thermodynamic efficiencies on the order of 25% were predicted.

#### **A.4 LOW POWER ENERGY CONVERSION SYSTEMS**

Three low power energy conversion systems were included in this trade study. They are discussed individually, below.

##### **A.4.1 Mini Turbine**

As with many energy conversion systems, turbine engines are quite efficient when operating at their design speeds but suffer significant performance degradation at lower, off-design, power levels. By incorporating a second turbine, optimized for the low-power condition, the relatively high efficiency and high power density of this device can be realized at both high and low power conditions.

Several mini turbine systems have been evaluated at ARL for the purpose of spinning alternators to produce electrical energy. For propulsion applications, this system would be coupled to an electric motor. When the weights and volumes of the alternator, its ancillary equipment, the motor controller electronics and the motor itself are included, the overall size and weight of a low power system based on a mini turbine / alternator combination is predicted to be quite large.

For this reason, this study assumed that a mini turbine system would be configured to drive a propulsor via a shaft, in the same manner as the high power conversion system. The main penalty associated with this approach is the need to develop a method to run the main drive shaft and alternator from either turbine. For this study, it was assumed that a second gearbox would be required and that its volume and weight would be equal to that of the high power gearbox. This is almost certainly a conservative assumption; even if the gearing requirement were doubled and a clutch were added, there would be some commonality in the housing, lubrication system, etc.

One factor that has not been adequately evaluated in ongoing hybrid torpedo analysis efforts is the design of propulsors for both low and high power operation. It may be challenging to design a single turbomachine that is capable of efficient operation over a very broad range of speeds. An alternative is installation of a separate propulsor configured for low-speed operation. This could take the form of a small pumpjet or tunnel thruster, which would be coupled to a mini turbine / mini-gearbox or else driven by an electric motor. The size and weight of this second thruster might prove to be smaller than the gearbox modifications, clutch mechanism, or other transmission machinery that would otherwise be required to couple low and high power propulsion systems to a single propulsor.

Most of the mini turbine systems evaluated at ARL are modified heavyweight or lightweight torpedo wheels and are therefore fairly large. The smallest optimized turbine design that has been tested at ARL is that of the CCAT / CVLWT engine which operates at a power level considerably

higher than that required for low power operation of a hybrid torpedo. The size of this system was therefore used as the basis for a mini turbine... this is certainly a conservative assumption but did not dramatically over penalize mini turbine systems relative to other alternatives as the actual weight and volume of the CCAT / CVLWT engine are very small.

The efficiency of mini turbine systems mirrors that of the larger propulsion systems to which they are paired. For a torpedo incorporating an open cycle high power engine, an open cycle mini turbine would be used, with a correspondingly lower efficiency than a mini turbine installed as a parallel prime mover in a system driven at high power by an Open Combustor Closed Cycle Rankine engine.

#### **A.4.2 PEM Fuel Cell**

A PEM fuel cell was included in this study primarily because these systems are generally considered to be closer to commercialization than solid oxide fuel cells. For this analysis, PEM cell volume and weight were predicted using trends identified by M. Klanchar of ARL on the basis of published data and COTS products.

The PEM cell is assumed to be applicable only to systems that use GH<sub>2</sub> fuel, since the size of a reformer system capable of producing hydrogen of suitable quality from alternative fuels (JP-5, MeOH, etc.) for use in a PEM cell was assumed to be too large for the torpedo application.

A 50% efficiency was assumed for the PEM cells in this study. This is an oft-quoted but probably somewhat optimistic value.

#### **A.4.3 Solid Oxide Fuel Cell**

A solid oxide fuel cell (SOFC) has an advantage over a PEM system in that it is capable of efficiently converting a feed containing carbon dioxide. This means that a relatively simple fuel processor stage can reform JP-5 or other liquid hydrocarbon fuels to a level sufficient for use in a SOFC.

For this study, data from Fuel Cell Energy, Inc., was used to estimate the size, weight and efficiency of the low-power fuel cell system.

The weight of the Fuel Cell Energy (FCE) complete fuel cell system was predicted to be on the same order as that of a PEM system, although the volume was considerably lower and the efficiency was markedly higher.



## **A.5 SUBCOMPONENT MODELS**

Table A1, below describes some of the assumptions made in sizing the individual hardware components that make up the high and low power conversion systems discussed above. Many of these models were developed under the multi-year ONR Sponsored "Hybrid Torpedo Concept Development" program. More details can be found in Table 2 in the body of this report. Note that component models that were modified for this study after the conclusion of the Phase I STTR program are highlighted in Table A1.

## **A.6 BUOYANCY CONCERNS**

A hybrid torpedo must be capable of operation at very low speeds. To accomplish this, the entire system will have to be neutrally buoyant or some mechanism must be provided to allow operation of a negatively buoyant system at very low speeds.

### **A.6.1 Neutrally Buoyant Systems**

For this study, two sets of analyses were performed. For the first set, neutral buoyancy was enforced. The mass of the complete propulsion system (fuel, oxidant, fuel tank, oxygen tank / oxygen generator, low power conversion system, high power conversion system and shell) was constrained to be less than or equal to the weight of seawater displaced by the propulsion section of the torpedo. As discussed above, this value is approximately 1650 pounds.

In some cases, the torpedo becomes positively buoyant over the course of its operation as fuel and oxidizer are consumed. In these systems, volume is allocated for a ballast tank. For configurations that use JP-5 fuel, the fuel tank is assumed to be "compensated" i.e. seawater is allowed to fill the fuel tank as JP-5 is withdrawn, thereby reducing the need for additional ballast tank volume. This is not possible for high pressure hydrogen or for MeOH (which is water soluble).

For this study, the "excess" volume associated with inefficient packaging of conversion system (and oxygen generator) hardware contributed to the buoyancy of the torpedo but was not assumed to be available for ballast tank applications. Empty volume left as the result of weight-limited fuel / oxidant loads contributed to both the initial buoyancy and ballasting requirements.

### **A.6.2 "Winged" Systems**

A second buoyancy option applied in this study assumed incorporation of a mechanism whereby a negatively buoyant weapon could operate at low speeds. Hypothetically, this could take the form of an inflatable bladder, the addition of small thrusters to provide vertical lift, a set of rotating (e.g. autogyro) blades, or a wing.

While the exact configuration of a lift-enhancing system is beyond the scope of this study, it was assumed that it would take the form of a wing that would somehow fold out from the body of the torpedo after launch and either retract or be jettisoned for transition to high speed mode.

The addition of a wing to a hybrid torpedo requires volume, mass and imposes an additional drag (i.e. power) penalty for low speed operation. Figure A4, shows how volume was allocated for a wing in this analysis. The total volume and weight penalties associated with this hypothetical structure are 2660 cubic inches of volume and 135 pounds. The wing was assumed to have a L/D ratio of 7, so for every seven pounds of lift required an additional 1 pound drag was assessed, and the propulsion power of the system was adjusted accordingly.

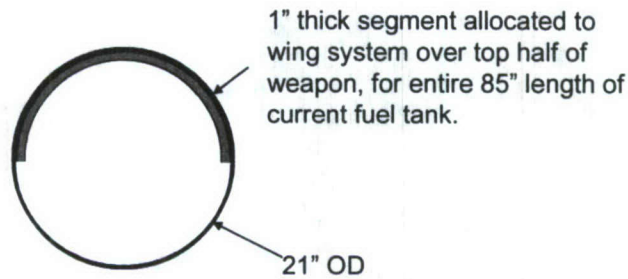

$$\frac{\pi}{4} \frac{(21^2 - 19^2)}{2} \cdot 85 = 2670 \text{ in}^3$$

**Figure A4: Cross Section of Hybrid Torpedo Showing Volume Allocated for Wing**

## A.7 CANDIDATE SYSTEMS

Figure 7, in the body of this report, attempts to show how the various fuel, oxidizer and high and low power conversion system choices can be assembled into a variety of feasible hybrid torpedo systems. Each of these 30 unique combinations was assigned a number, as shown in Table 2.

Note that only "feasible" configurations are included in this matrix. Systems that do not make physical sense, for example a JP-5 fueled PEM cell, were not considered.

Figures A5 and A6 show the volumes and weights, respectively, for the various components of systems 1 through 30 (per Table A2) in the neutrally buoyant configuration. Figures A7 and A8 show the same data for the "Winged" systems.

**Table A. 1: Subcomponent Model Assumptions**

Subsystem	Used In	Assumptions
Overall Vehicle	All	Torpedo Mk. 48 size envelope Internal volume estimated from ARL / Water Tunnel data Fuel tank and 70% of tailcone volume available for powerplant Shell displacement ~ 1650 lb seawater Shell section weight ~ 430 lb Mechanical components pack with 2/3 efficiency
Speed / Power		5 kt low speed (per sponsor) 60 kt high speed (per sponsor) 6 hp (4.47 kW) hotel power
Combustor	OC OCCCR CCR Mini-Turbine	Based on hybrid combustor model developed by J. Cor of ARL. <b>Combustor efficiency calculations added for updated study.</b>
Gearbox	OC OCCCR CCR Mini-Turbine	Gearbox model provided by Nichols, Inc. was used (Lowe, 2005). Metrics developed at ARL based on previous SCEPS systems were used to estimate weights and volumes for comparison... larger (more conservative) weight / volume was selected for trade study.  Use of mini-turbine system was assumed to double the weight and volume of gearbox.
Turbine		Gearbox efficiencies of 95% were assumed. Turbine model provided by Barber-Nichols, Inc. (Lowe, 2005) was used. Metrics developed at ARL based on previous SCEPS systems were used to estimate weights and volumes for comparison... larger (more conservative) weight / volume was selected for trade study.  Mini-turbine (low power) weight / volume was based on CCAT / CVLWT turbine and housing.
Motor	PEM SOFC	<b>Motor and motor-controller sizes and efficiencies for trade study now based on NUWC-NPT (Roberts, 2006) data.</b>
Motor Controller		
Heat Exchanger	OCCCR	<b>Coaxial steam generator model provided by NUWC-NPT (Roberts, 2006) was incorporated in updated trade study.</b>
Hotwell	OCCCR CCR	Sized to hold 20 second supply of working fluid based on high power.
Condenser	OCCCR CCR	No size or weight allocated to the condenser, as it is assumed to be a shell condenser similar to those used in SCEPS systems. The volume and weight penalties of this component are minimal.
Misc. components; Pumps, Regenerator, Etc.	All	Small allowance made for feedwater pumps. Fuel pump assumed to be incorporated in relatively generous fuel storage system weight allowance. Regenerator component is incorporated in ARL turbine / gearbox housing model.

Table A. 2: System Configuration Matrix

System Designation Number	Fuel	Oxidizer	Low-Power Conversion System	High Power Conversion System
1	JP-5	GOX	SOFC (Solid Oxide Fuel Cell)	OCCCR (Open Combustor, Closed Cycle Rankine)
2	GH2	GOX	PEM (Proton Exchange Membrane Fuel Cell)	CCR (Closed Cycle Rankine)
3	MEOH	GOX	SOFC	OCCCR
4	JP-5	LOX	SOFC	OCCCR
5	GH2	LOX	PEM	CCR
6	MEOH	LOX	SOFC	OCCCR
7	JP-5	LiClO <sub>4</sub>	SOFC	OCCCR
8	GH2	LiClO <sub>4</sub>	PEM	CCR
9	MEOH	LiClO <sub>4</sub>	SOFC	OCCCR
10	JP-5	GOX	MINI_TURB	OCCCR
11	GH2	GOX	MINI_TURB	CCR
12	MEOH	GOX	MINI_TURB	OCCCR
13	JP-5	LOX	MINI_TURB	OCCCR
14	GH2	LOX	MINI_TURB	CCR
15	MEOH	LOX	MINI_TURB	OCCCR
16	JP-5	LiClO <sub>4</sub>	MINI_TURB	OCCCR
17	GH2	LiClO <sub>4</sub>	MINI_TURB	CCR
18	MEOH	LiClO <sub>4</sub>	MINI_TURB	OCCCR
19	JP-5	GOX	SOFC	OC (Open Cycle)
20	MEOH	GOX	SOFC	OC
21	JP-5	LOX	SOFC	OC
22	MEOH	LOX	SOFC	OC
23	JP-5	LiClO <sub>4</sub>	SOFC	OC
24	MEOH	LiClO <sub>4</sub>	SOFC	OC
25	JP-5	GOX	MINI_TURB	OC
26	MEOH	GOX	MINI_TURB	OC
27	JP-5	LOX	MINI_TURB	OC
28	MEOH	LOX	MINI_TURB	OC
29	JP-5	LiClO <sub>4</sub>	MINI_TURB	OC
30	MEOH	LiClO <sub>4</sub>	MINI_TURB	OC

## A.8 TRADE STUDY RESULTS

Figures A.9 and A.10 show the ranges of hybrid torpedo systems as predicted by the trade study model discussed in the previous section. Figure A9 shows data for those systems which are configured to be neutrally buoyant, while Figure A10 represents the performance of winged systems. The independent "System Type" variable in each case corresponds to those outlined in Table A.2.

Each range plot includes three sets of bar graphs. The tallest (red) set shows the range if the torpedo were to operate at low speed for the entire duration of the mission. The yellow bars show the range at low-speed if enough fuel and oxidant were reserved to support a 10 NMi (20.3 kYd) "burst" attack, i.e. the baseline mission defined at the beginning of the program by the technical sponsor. The blue bars show the range if the weapon were to operate completely at high speed.

In some cases, the high speed range is less than 20 kYd in which case the baseline mission cannot be performed, and no yellow bar is present. For the neutrally buoyant case, only 5 of the 30 system configurations are theoretically capable of meeting this very challenging mission requirement.

The data shown in Figures A5 through A10 represent the results of the updated trade study performed as part of the current "Hybrid System Concept Development" program. Because the underlying component models and assumptions were changed for this new analysis, the volume / weight breakdown charts and predicted range plots differ significantly from those included in the Phase I STTR report (Barber-Nichols, Inc., 2006). Qualitatively, however, the overall conclusions of the current study are identical to those of the previous analysis.

In summary, the trade study identified three key enabling technologies that govern the endurance of a hybrid torpedo. First, a dense oxygen source is critical. Since the amount of oxidizer that needs to be carried generally has a volume many times that of the fuel, increased oxygen storage density has a disproportionate effect on torpedo performance.

Second, if solid oxide fuel cells live up to their promised efficiency the savings in fuel and oxidant more than compensate for the increased size and complexity of this system relative to other alternatives such as miniturbines.

Finally, the use of buoyancy enhancing features such as wings, inflatable or morphing bladders, autogyro rotors etc. has a strong potential influence on the range of a hybrid torpedo. The increase in range associated with the extra fuel and oxidant that can be carried more than offsets the weight, volume and added drag associated with these features. This is particularly true if a dense but heavy oxidant source such as lithium perchlorate is used.

Of course, the optimal configuration for a hybrid torpedo is governed by the metric by which its performance is judged. The following sections discuss three specific performance metrics and the optimal system configurations for each, assuming both neutral buoyancy and winged configurations.

### A.8.1 Metric #1: Range at Low Power

For both the neutrally buoyant vehicle and the winged vehicle, the highest range at low-power is associated with system #23, which (as shown in Table 2) uses JP-5 as the fuel, a lithium

perchlorate based oxygen generator, a solid oxide fuel cell for low power and an open cycle engine for high power.

This result reflects the fact that the compact open cycle engine allows additional fuel and oxidizer to be carried yet the relative inefficiency of this system does not adversely affect performance, since the entire mission is performed at low-speed. The large size of the low power conversion system (SOFC) is more than offset by its very high efficiency.

This system's high speed range is approximately 17 kYd... less than the high speed reserve specified for the mission of record, so (as with most configurations) this system cannot perform the mission of record.

### **A.8.2 Metric #2: Range at High Speed**

For the neutrally buoyant condition, system #13 has the best high speed range. As shown in Table 2, this configuration consists of JP-5 fuel combined with liquid oxygen, a mini-turbine system for low power operation and an Open Combustor Closed Cycle Rankine (OCCCR) system for high power operation.

In this case, the increased efficiency of the high power conversion system more than offsets its increased volume and weight. The relative inefficiency of the mini-turbine system does not adversely affect system performance because it is not used for a mission that consists entirely of high power operation.

For winged systems, the highest range for a high speed mission is associated with system #16, which uses the same fuel and conversion systems as configuration #13 but a lithium perchlorate based chemical oxygen source. By permitting low-speed operation of this non-neutrally buoyant system, the wing allows the very oxygen dense but heavy chemical oxygen source to be used to full effect

### **A.8.3 Metric #3: Mission of Record**

For the mission of record, in which a reserve of fuel and oxidizer is held for a final 10 NMi (20.3 kYd) burst, system #4 has the highest overall range in the neutrally buoyant condition. This consists of a JP-5 / LOX combination with a SOFC for low power operation and an OCCCR engine for high power. This reflects the fairly high energy density of this fuel / oxidant pair coupled to efficient low and high power conversion systems.

In the winged configuration, the highest overall range for the mission of record is associated with system #7, which differs from system #4 in that  $\text{LiClO}_4$  is substituted for LOX. Again, this shows the effect of the wing which allows the efficient use of this dense but heavy oxygen source.

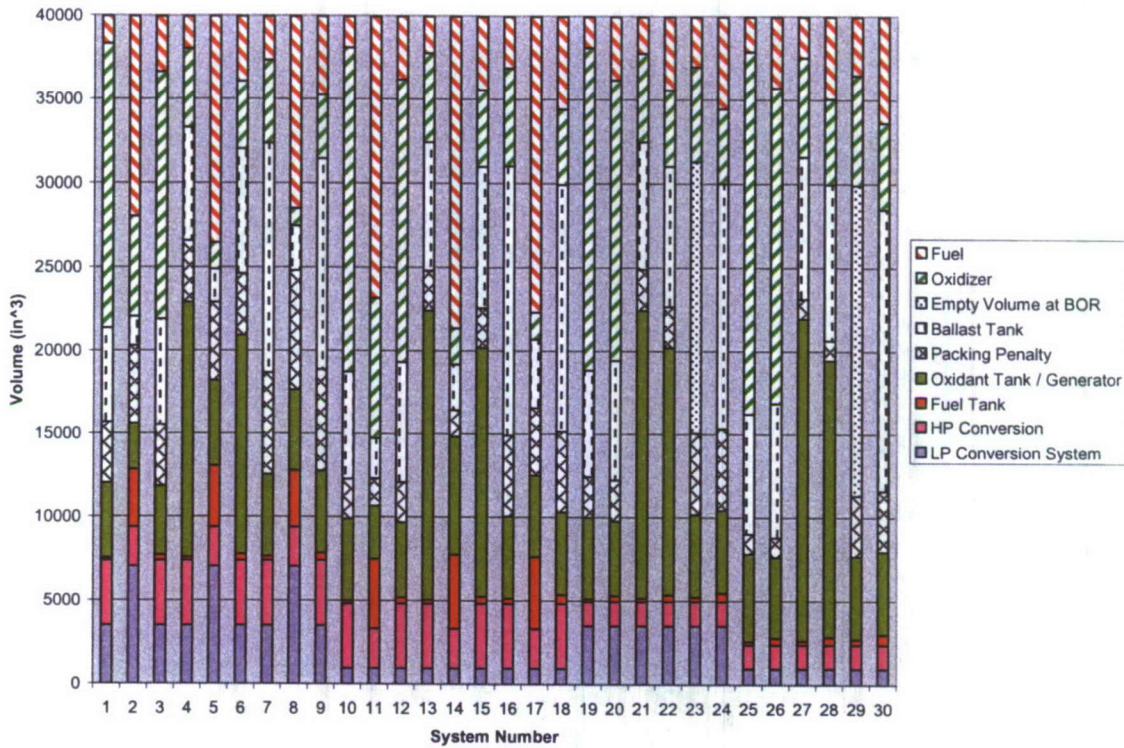

Figure A5: Component Volumes - Neutrally Buoyant Systems

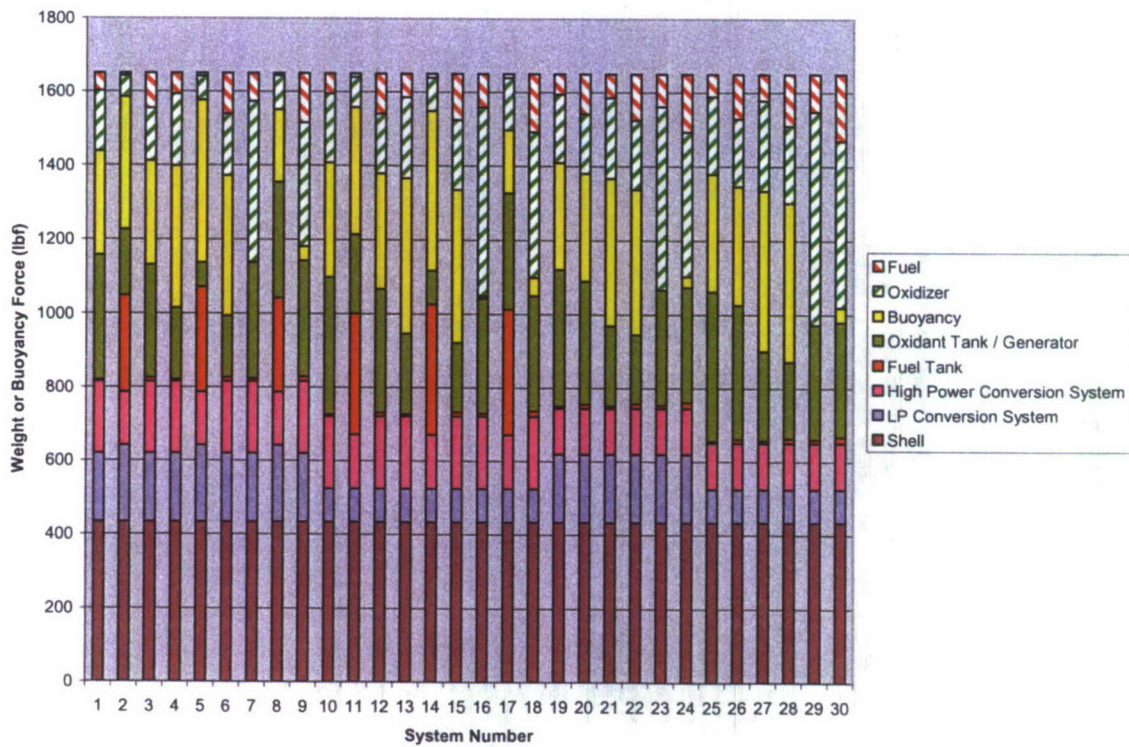

Figure A6: Component Weights - Neutrally Buoyant Systems

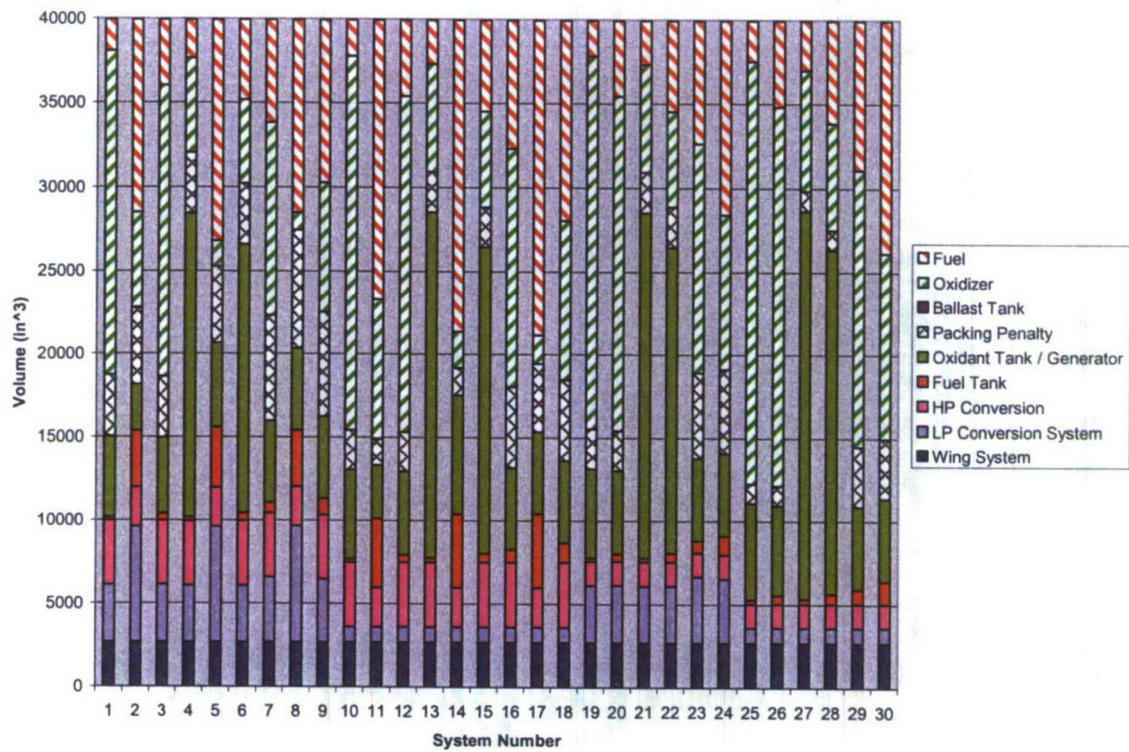

Figure A7: Component Volumes - "Winged" Systems

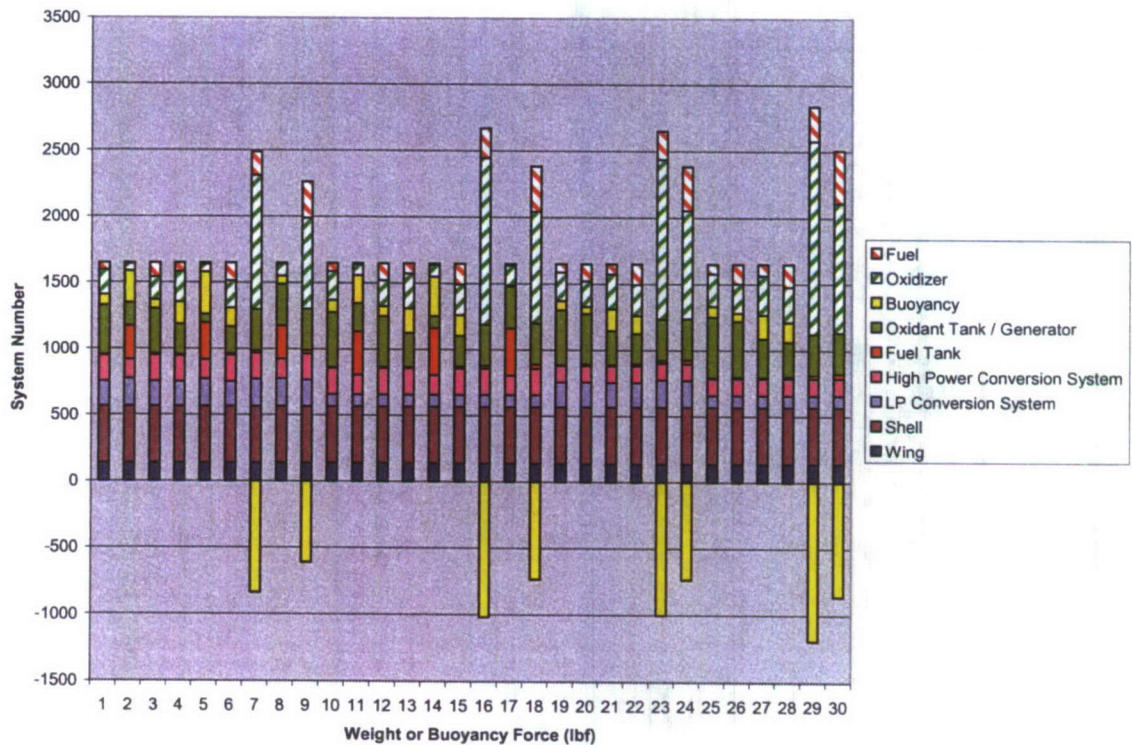

Figure A8: Component Weights - "Winged" Systems



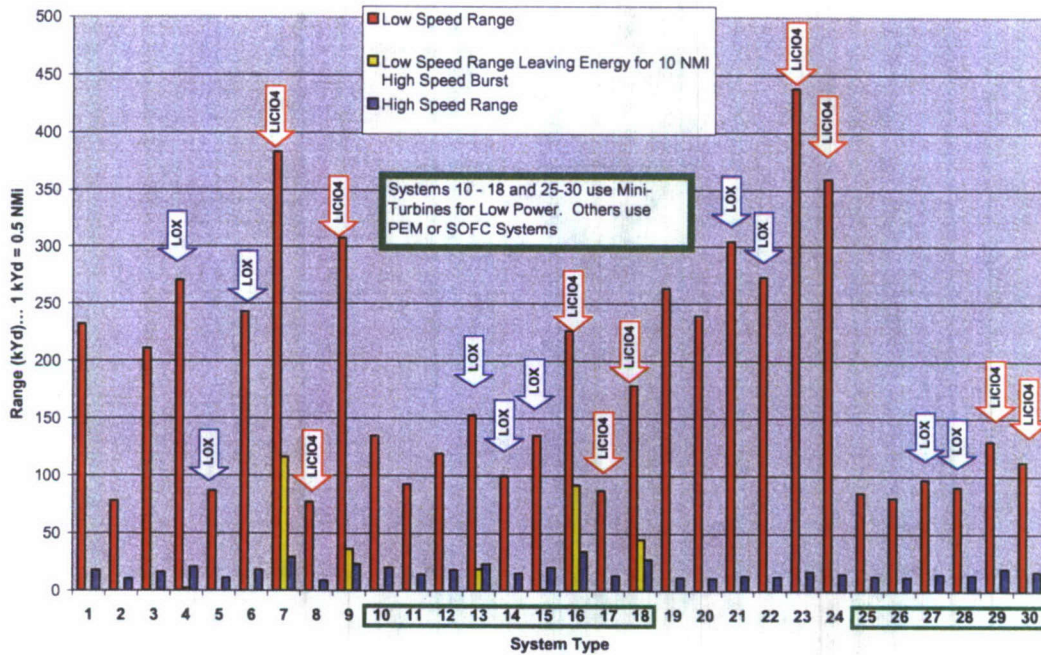

Figure A9: Ranges for Neutrally Buoyant Systems With Oxygen Source Identified (Lack of Arrow implies 3000 PSI GOX Storage)

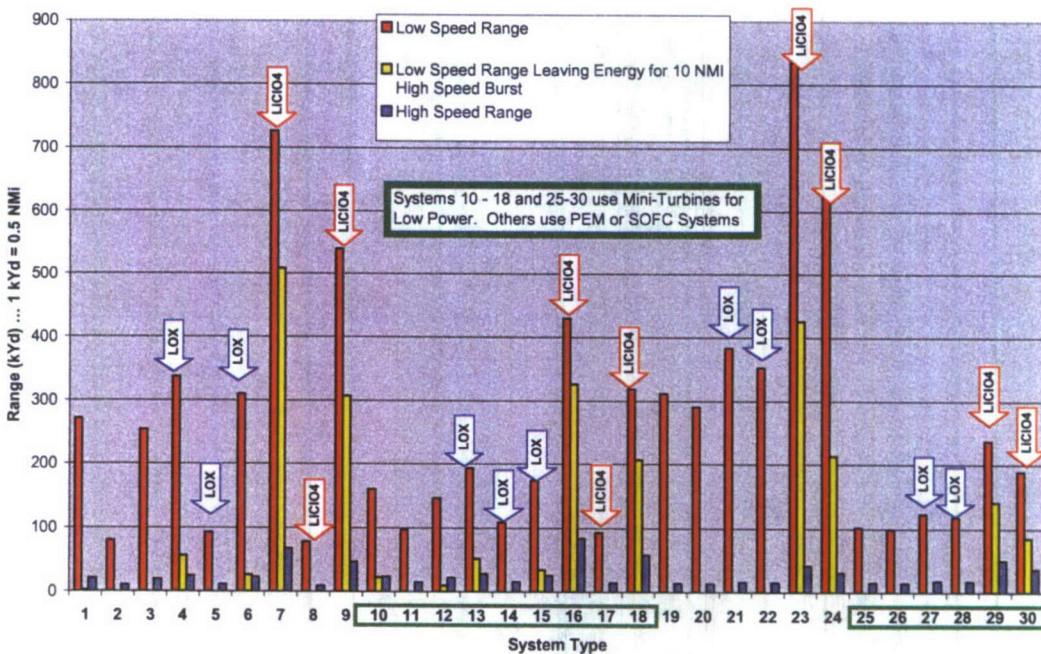

Figure A10: Ranges for "Winged" Systems With Oxygen Source Identified

Table A3, below, is a sensitivity analysis that shows the relative importance of the three key enabling technologies (fuel cell, wing, chemical oxygen source) on the overall range for the three mission profiles shown by the color coded bars in Figures A7 and A8.

For the “hybrid like” mission (which is a run at low-power with enough reserve for a 20 kYd burst at high speed) a fuel cell offers a 34% improvement relative to other options such as miniturbines.

Lack of a buoyancy enhancement system (such as a deployable wing) results in a 74% reduction in range because the amount of fuel and oxidizer than can be carried is significantly curtailed in order to make the vehicle neutrally buoyant.

Lack of a dense chemical oxygen source has an 86% impact on range because other alternatives such as high pressure oxygen or liquid oxygen do not supply anywhere near as much oxygen per unit volume.

Two of these three enabling technologies will be addressed in a planned Phase II STTR program, which includes demonstrations of a lithium perchlorate based chemical oxygen source and a solid oxide fuel cell configured for a hybrid torpedo.

**Table A3: Impact of Key Technologies**

Technologies Missing...		Low Speed Mission	20 kYd Reserve (Mission of Record)	High Speed Mission
None	Designation of Best System	#23	#7	#16
	Range (kYd)	835	528	84
No Fuel Cell	Designation of Best System	#16	16	#16
	Range (kYd)	430	346	84
	<i>Relative Impact</i>	<i>-49%</i>	<i>-34%</i>	<i>-0%</i>
No Wings	Designation of Best System	23	#7	#16
	Range (kYd)	438	136	34
	<i>Relative Impact</i>	<i>-48%</i>	<i>-74%</i>	<i>-60%</i>
No Chemical Oxygen Source	Designation of Best System	#21	#4	#13
	Range (kYd)	383	76	28
	<i>Relative Impact</i>	<i>-54%</i>	<i>-86%</i>	<i>-67%</i>

## A.9 TRADE STUDY CONCLUSIONS

A number of general conclusions can be drawn from the results summarized in Figures A9 and A10 and Table A3.

1. In neutrally buoyant configurations, some LOX-based systems approach or exceed the performance of similar configurations that use  $\text{LiClO}_4$ . This is not surprising... LOX naturally combines with a variety of fuels to produce neutrally buoyant systems. For example, the specific gravity of the LOX / JP-5 pair is about  $1042 \text{ kg/m}^3$ , just above that of seawater.
2. Throughout this discussion, the concerns discussed in a previous section regarding the suitability of LOX as a torpedo fuel should be borne in mind.
3. As discussed above, the wing model used in this effort is relatively crude. However, it is clear that providing a mechanism that permits operation of a non-neutrally buoyant torpedo at very low speeds results in tremendous increases in range.
4. As expected, the effect of wings is particularly pronounced for systems that use the very oxygen dense but heavy  $\text{LiClO}_4$  - based chemical oxygen source. As shown in Figure A10,  $\text{LiClO}_4$ -based systems outperform all others when neutral buoyancy is not a concern.
5. The reduced fuel / oxidizer volume associated with addition of the wing and with the relatively large and heavy oxygen generator system is more than offset by the significantly increased oxygen storage density
6. Fuel cell based systems generally outperform miniturbine systems by a considerable margin. This implies that the most dramatic benefit of a chemical oxygen source is realized if an  $\text{O}_2$  generator is configured to produce pure oxygen.
7. The use of a combustor system to burn fuel with an aqueous solution of perchlorate is a viable but somewhat less effective mechanism for accessing the high oxygen storage density of  $\text{LiClO}_4$ . Systems configured with this type of chemical oxygen source would be limited to the use of a mini-turbine system for low power operation. As shown in Figure A10, these configurations give excellent performance relative to GOX and LOX based systems, but fall short of the range that could be realized through the use of a fuel cell, which requires a source of pure oxygen. Another option would be to incorporate a separate low power pure oxygen generator in addition to a direct perchlorate fed high power combustor.
8. None of the top-ranked propulsion system configurations in either neutrally buoyant or the winged weapons utilizes gaseous oxygen. This reflects the relatively low storage density and fairly heavy tankage requirements of this alternative.
9. Substitution of GOX tanks for  $\text{LiClO}_4$  generators does, however, represent a method of producing a relatively low-cost exercise variant of a hybrid torpedo that can demonstrate all of the operating capabilities of the warshot weapon, albeit at a reduced range.
10. None of the top-ranked propulsion system configurations in either the neutrally buoyant or winged weapons uses gaseous  $\text{H}_2$  storage, reflecting the relatively poor performance of this fuel compared to the liquid hydrocarbons.

11. There are some conditions under which a methanol-fueled vehicle outperforms the corresponding JP-5 fueled configuration, despite the fact that methanol has a lower heat of reaction when burned with oxygen gas. This effect is due to the reduced oxygen demand of these systems. A stoichiometric JP-5/O<sub>2</sub> ratio is 77% oxygen by weight, whereas the corresponding ratio for a MeOH system is 60%. None of the highest ranked systems uses methanol, however.

## REFERENCES: APPENDIX A

Barber-Nichols, Inc., "Hybrid Propulsion Systems for Undersea Weapons" (Phase I STTR Final Report, Topic N05-T024), February 6, 2006

Dunn, P., "Torpedo Bi-Propellant Efforts and Applicability," (NUWC-NPT Presentation for PMO-402), Date Unknown

Haberbusch, M. S. et. al., "Rechargeable Cryogenic Reactant Storage and Delivery System for Fuel Cell Powered Underwater Vehicles," Proceedings of the 2002 Workshop on Autonomous Underwater Vehicles. June, 2002

Lowe, David, (Barber-Nichols, Inc.), Personal communication with author, 2005.

Pressure Vessel Engineering, Inc., *Flanged and Dished Head ver 2.13.xls*, Downloaded from [www.pveng.com](http://www.pveng.com), 2005.

Roberts, R. W., (NUWC-NPT), Personal communications with author throughout 2006.

**Distribution List for Unclassified TR-07-004 by Jonathan A. Peters,  
dated December 2007**

Dr. Kam W. Ng  
Program Officer  
Office of Naval Research  
875 North Randolph Street  
Suite 1425, Code 333  
Arlington, 22203-1995

Director, Naval Research Lab  
Attn: Code 5227  
4555 Overlook Avenue, SE  
Washington, DC 20375-5320

Defense Technical Information Center  
8725 John J. Kingman Road  
STE 0944  
Ft. Belvoir, VA 22060-6218