



Defence Research and
Development Canada

Recherche et développement
pour la défense Canada



Survey of Network Visualization Tools

Adam Gort and James Gort

The scientific or technical validity of this Contract Report is entirely the responsibility of the Contractor and the contents do not necessarily have the approval or endorsement of Defence R&D Canada.

Defence R&D Canada – Ottawa

CONTRACT REPORT
DRDC Ottawa CR 2007-280
December 2007

Canada

Survey of Network Visualization Tools

Adam Gort
James Gort
NRNS Incorporated

Prepared By:
NRNS Incorporated
4043 Carling Avenue, Suite 106
Ottawa, Ontario, K2K 2A3
Contract Project Manager:
CSA: Joanne Treurniet, 613-990-7096

The scientific or technical validity of this Contract Report is entirely the responsibility of the Contractor and the contents do not necessarily have the approval or endorsement of Defence R&D Canada.

Defence R&D Canada – Ottawa

Contract Report
DRDC Ottawa CR 2007-280
December 2007

Scientific Authority

Original signed by J. Treurniet

J. Treurniet

Approved by

Original signed by J. Lefebvre

J. Lefebvre

Head/NIO Section

Approved for release by

Original signed by P. Lavoie

P. Lavoie

Chief Scientist Defence R&D Canada - Ottawa

- © Her Majesty the Queen in Right of Canada, as represented by the Minister of National Defence, 2007
- © Sa Majesté la Reine (en droit du Canada), telle que représentée par le ministre de la Défense nationale, 2007

Abstract

As a first step in determining the way ahead for research and development of network visualisation techniques, a product and literature search of network visualisation technologies was conducted. The contractors developed a taxonomy of network visualisation product attributes and entered products into a MySQL database accessed through a web interface using PHP scripts. A report containing a table for each of the 139 products was delivered in HTML format; each table includes the attributes that could be determined from the product's Internet presence or from sales staff, and screen captures where available. This document contains a re-formatted version of this full report, fitted to letter size paper and with unfilled rows removed from the tables to minimize the document length. The citation information for the 27 documents discovered in the literature search are listed at the end, along with the abstract of each.

Résumé

Comme première étape consistant à déterminer les perspectives de recherche et de développement de techniques permettant la visualisation réseau, une recherche documentaire et de produits portant sur les technologies de visualisation réseau a été menée. Les entrepreneurs ont développé un système de classification des attributs de produits de visualisation réseau, puis ont entré ces produits dans une base de données MySQL accessible par le biais d'une interface Web utilisant des scripts PHP. Un rapport contenant un tableau pour chacun des 139 produits a été transmis en format HTML. Chaque tableau renferme les attributs pouvant être déterminés d'après certaines conditions comme la présence du produit sur Internet ou la disponibilité du personnel de vente et les saisies d'écran, le cas échéant. Ce document renferme également une version du rapport qui a été restructurée de manière à ce qu'il puisse être imprimé sur du papier format commercial; les rangées en blanc ont également été supprimées des tableaux afin de réduire la longueur du document. Les informations de citation reliées aux 27 documents trouvés au cours de la recherche documentaire sont listées à la fin du document, de même que leur résumé respectif.

This page intentionally left blank.

Introduction

As a first step in determining the way ahead for research and development of network visualisation techniques, a product and literature search of network visualisation technologies was conducted.

The product survey required that a taxonomy of product attributes be developed so that each product could be classified according to:

- The context in which the product was intended to be used;
- The network representation, e.g. the layout algorithms provided, the node and link attributes, or any specific type of network for which the product is designed;
- The analysis capabilities provided by the product, specifically network analysis measurements and also general statistical measurements, as well as visual abstractions of the data that cannot be laid out as nodes and links;
- Visual enhancements, such as animation;
- User interaction capabilities of the product;
- Attributes related to the deployment of the product, such as scalability, operating system (OS), interoperability and cost.

The contractors created a MySQL database accessed through a web interface using PHP scripts and entered 139 products into the database. A report containing a table for each of the products was delivered in HTML format; each table includes the attributes that could be determined from the product's Internet presence or from sales staff, and screen captures where available. This document contains a re-formatted version of this full report, fitted to letter size paper and with unfilled rows removed from the tables to minimize the document length.

The final section of this report contains the results of the literature search for network visualisation research. The focus of the literature search was computer networks, and 27 documents were found. The citation information for the documents are listed, along with the abstract of each.

Survey of Network Visualization Tools

- [3DTraceRoute](#)
- [AGD - Algorithms for Graph Drawing](#)
- [AGNA](#)
- [aiSee](#)
- [AlgoCOMs DIAGRAM](#)
- [AlgoCOMs NETWORK](#)
- [Amerigo for HP Openview](#)
- [Analyst's Notebook](#)
- [Animated Exploration of Dynamic Graphs with Radial Layout](#)
- [Ask-Graphview](#)
- [big:eye](#)
- [Blanche](#)
- [BMC Topology Discovery](#)
- [Boost Graph Library](#)
- [CCVisu](#)
- [cheops-ng](#)
- [ConceptDraw NetDiagrammer](#)
- [Coplinc](#)
- [Corgent Diagram for .NET](#)
- [Daisy](#)
- [DyNet](#)
- [Eye of the Storm](#)
- [GDToolkit](#)
- [GeoPlot](#)
- [GINY - Graph INterface librarY](#)
- [GLuskap](#)
- [GMorph](#)
- [GoDiagram](#)

- [GoVisual](#)
- [Graph Magics](#)
- [Graph Visualization Library \(VTK\)](#)
- [GraphAEL](#)
- [Graphlet and GTL](#)
- [graphopt](#)
- [GraphPlot](#)
- [Graphviz](#)
- [Gravisto](#)
- [GRIP/GUIDE](#)
- [GTrace](#)
- [GUESS: The Graph Exploration System](#)
- [GVF - The Graph Visualization Framework](#)
- [H3Viewer](#)
- [HP Openview Network Node Manager](#)
- [HyperGraph](#)
- [Hypertree](#)
- [HyperTree Java Library](#)
- [IBM Tivoli NetView](#)
- [igraph](#)
- [ILOG JViews Diagrammer](#)
- [ILOG Views Graph Layout](#)
- [InFlow](#)
- [InfoVis Toolkit](#)
- [Inxight StarTree](#)
- [IPsonar](#)
- [IronView Network Manager](#)
- [IVC - Information Visualization CyberInfrastructure](#)
- [Java Graph Framework](#)
- [JDigraph](#)
- [JGraph and JGraph Layout Pro](#)
- [JGraphT](#)
- [JUNG](#)
- [Kliquefinder](#)
- [KrackPlot](#)
- [LANsurveyor](#)
- [Large Graph Layout](#)
- [LEDA](#)
- [LibSea](#)
- [Link Analyst](#)
- [LinLogLayout](#)
- [LoriotPro](#)
- [Mapnet](#)
- [Mathematica](#)
- [MatrixExplorer](#)
- [MERL](#)
- [Monarch Graph](#)
- [Nagios](#)
- [Nam: Network Animator](#)
- [Net-Probe](#)
- [NetCool Precision for IP Networks](#)
- [NetCrunch](#)
- [Netlayout](#)
- [NetMap](#)
- [NetMiner](#)
- [NetMiner for Web](#)
- [NetVis](#)
- [netViz Enterprise](#)
- [NetVizor](#)
- [NetworkX](#)
- [Nevron Diagram for .Net](#)
- [NIVA](#)
- [Nomad](#)
- [NV2D](#)
- [OpenNMS](#)
- [Otter](#)
- [P-Graphs](#)
- [P.I.G.A.L.E.](#)
- [Pajek](#)
- [Passive/Active Network Monitoring Tool \(PNMT/ANMT\)](#)
- [Patrol Visualis](#)
- [PingTV](#)
- [PlotPaths](#)
- [PPCGraph](#)
- [prefuse](#)
- [PyGraphvis](#)
- [SemaSpace](#)
- [SHriMP](#)
- [SIMG](#)
- [SNMPc](#)
- [Social Networks Visualiser](#)
- [SoNIA \(Social Network Image Animator\)](#)
- [Sourcefire](#)
- [SpaceTree](#)
- [SpatialFX](#)
- [Starlight](#)

- [Swift3D](#)
- [TeCFlow](#)
- [TGRIP: Temporal Graph dRawing with Intelligent Placement](#)
- [The Dude](#)
- [ThinkMap](#)
- [Tom Sawyer Toolkits](#)
- [TopFish](#)
- [TouchGraph](#)
- [TreePlus](#)
- [Tulip](#)
- [UCINET 6 / NetDraw](#)
- [uDraw](#)
- [VANTED](#)
- [ViAGraph](#)
- [Visone](#)
- [VisuaLinks](#)
- [VisuaLyzer](#)
- [VRMLGraph](#)
- [Walrus](#)
- [Web NMS](#)
- [WhatsUp Professional Premium 2006](#)
- [WilmaScope](#)
- [XGvis](#)
- [yFiles](#)
- [Zest: The Eclipse Visualization Toolkit](#)

Name	3DTraceRoute	
URL	http://www.d3tr.de/index.html	
Description	Brief description: Displays computer traffic in 3D, with multiple graphics options. Detailed description:	
<u>Product Version/Status</u>	PRO: 2.1.8.18 Release date: 2005-08-30 PRO Beta 2.2.16.31 Release date: 2006-02-09	
Context		
<u>Main Functionalities</u>	<ul style="list-style-type: none"> • Graph Viewing • Network Analysis 	Comments:
<u>Domain</u>	<ul style="list-style-type: none"> • Computer Networks 	Comments:
Network Representation		
<u>Dimensionality</u>	<ul style="list-style-type: none"> • 2D • 3D • Geospatial 	Comments:
Analysis		
<u>General Analysis</u>	<ul style="list-style-type: none"> • Statistics:Frequency 	Comments:
<u>Network Analysis</u>	<ul style="list-style-type: none"> • Properties:Network 	Comments:
Deployment		
	<u>Type:</u> <ul style="list-style-type: none"> • Standalone Tool 	<u>OS:</u> <ul style="list-style-type: none"> • Windows
<u>Cost</u>	\$1 - \$100	Comments: Pro Version

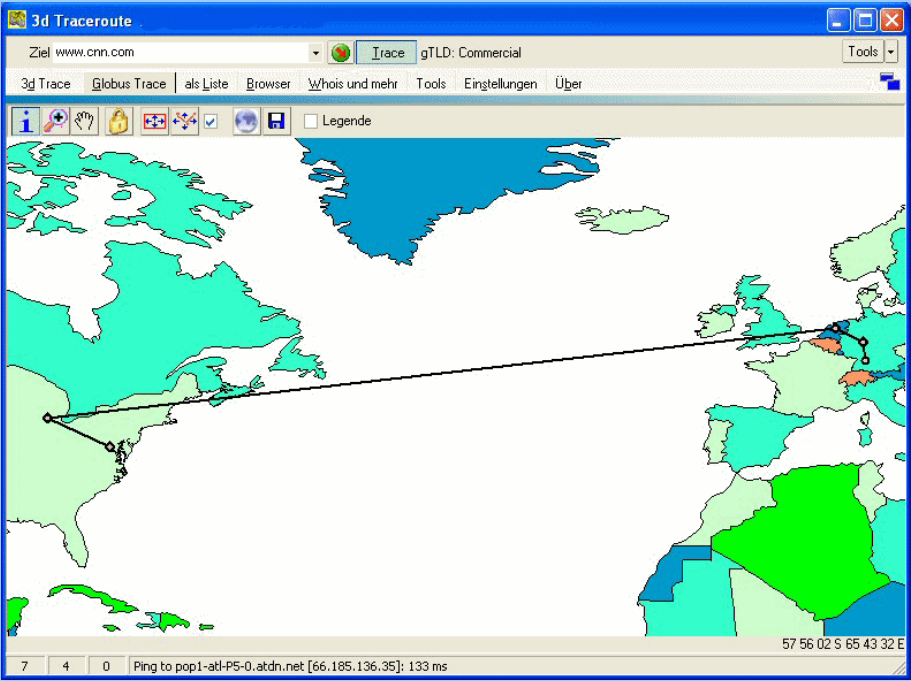
<p>Images</p>	
<p>Last Modified</p>	<p>2006-12-10 16:39:16</p>

<p>Name</p>	<p>AGD - Algorithms for Graph Drawing</p>	
<p>URL</p>	<p>http://www.ads.tuwien.ac.at/AGD/</p>	
<p>Description</p>	<p>Brief description: AGD, a library of Algorithms for Graph Drawing, offers a broad range of existing algorithms for two-dimensional graph drawing and tools for implementing new algorithms.</p> <p>Detailed description:</p>	
<p>Product Version/Status</p>	<p>1.3 (released on 04-Dec-2003)</p>	
<p>Context</p>		
<p>Main Functionalities</p>	<ul style="list-style-type: none"> Automated Layout Graph Viewing 	<p>Comments:</p>
<p>Domain</p>	<ul style="list-style-type: none"> Any 	<p>Comments:</p>
<p>Network Representation</p>		
<p>Layout Algorithms</p>	<ul style="list-style-type: none"> Clustered Grid Hierarchical (Sugiyama) Orthogonal Planar Planar:Convex Planar:FPP 	<p>Comments: http://www.ads.tuwien.ac.at/AGD/MANUAL/Layout_Algorithms_in.html</p>

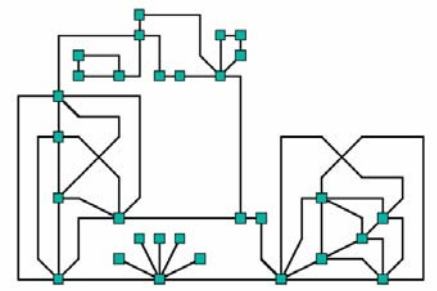
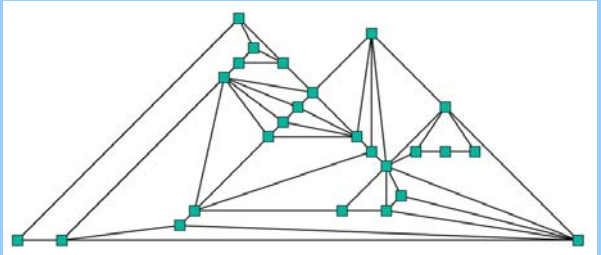
	<ul style="list-style-type: none"> • Planar:Schnyder • Spring (Tutte) • Spring FR • Tree:Walker 	
<u>Dimensionality</u>	<ul style="list-style-type: none"> • 2D 	Comments:
Deployment		
	<u>Type:</u> <ul style="list-style-type: none"> • Components for tool building 	<u>OS:</u>
<u>Extensibility</u>	<ul style="list-style-type: none"> • C++ 	Comments: AGD contains a tool set for implementation of new algorithms.
<u>Interoperability</u>	A Client-Server mechanism allows the use of AGD from within other applications.	
<u>Cost</u>	Free - For noncommercial use	Comments:
Images		
		
Last Modified	2006-12-10 16:39:16	

Name	AGNA
URL	http://www.geocities.com/imbenta/agna/index.htm
Description	<p>Brief description: Agnas is a platform-independent application designed for social network analysis, sociometry and sequential analysis.</p> <p>Detailed description: AGNA (Applied Graph & Network Analysis) is a platform-independent application designed for scientists and researchers who employ specific mathematical methods, such as social network analysis, sociometry and sequential analysis.</p> <p>Specifically, Agna can assist in the study of communication relations in groups, organizational analysis and team building, kinship relations or animal behaviour laws of organization.</p>
Product Version/Status	The most recent version is Agna 2.1.1 (released: 12th December, 2003)

Context		
<u>Domain</u>	<ul style="list-style-type: none"> Social Networks 	Comments:
Network Representation		
<u>Layout Algorithms</u>	<ul style="list-style-type: none"> Circular Random 	Comments:
<u>Dimensionality</u>	<ul style="list-style-type: none"> 2D 	Comments:
Analysis		
<u>Network Analysis</u>	<ul style="list-style-type: none"> Centrality Centrality:Closeness Centrality:Degree Cohesion Cohesion:Average Distance Connection:Distance Connection:Shortest Path 	Comments:
User Interaction		
<u>User Interaction</u>	<ul style="list-style-type: none"> Add/Delete Clone GUI Spreadsheet 	Comments:
Deployment		
	<u>Type:</u> <ul style="list-style-type: none"> Standalone Tool 	<u>OS:</u> <ul style="list-style-type: none"> Multi-Platform (JAVA)
<u>Interoperability</u>	<p>Import/Export file formats are limited to AGNA Data File Format (*.agn), Comma Separated Values (*.csv), and Text tab-separated (*.txt, *.dat, *.text). The Agna Data File Format is an open file format; therefore, other application can be made to import/export *.agn files.</p> <p>At present Agna can export two image file formats: SVG and JPEG</p>	
<u>Scalability</u>	<p>Max Nodes: Unlimited</p> <p>Max Links: Unlimited</p>	Comments: There is no upper limit, but a warning will be sent if the number of nodes exceeds 300. Depending on your system, processing data from large networks may lead to slow operations.
	<u>Hardware:</u>	<u>Users:</u>
		<u>Availability:</u> <ul style="list-style-type: none"> Freeware
<u>Cost</u>	Free	Comments:

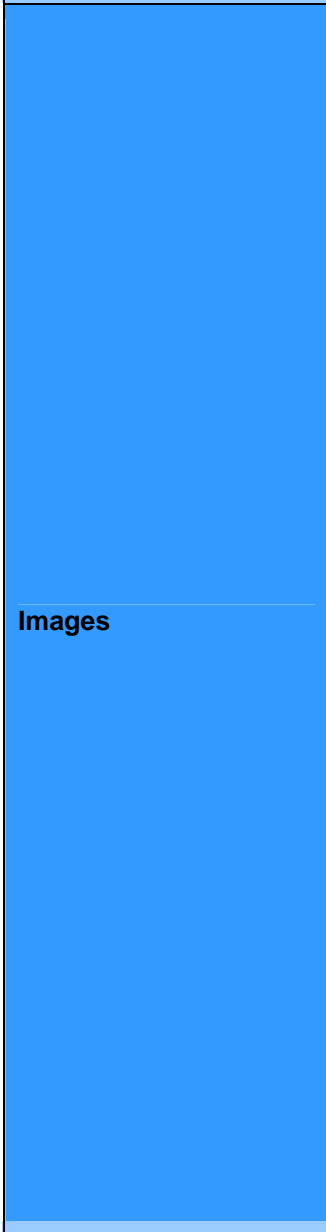

Images

weighted - Agna 2 beta

Andy	0.0	0.0	1.0	0.0	0.0	0.0	0.0	1.0	0.0
Thom	1.0	0.0	0.0	0.0	0.0	0.0	0.0	0.0	0.0
Helen	4.0	0.0	0.0	0.0	0.0	0.0	0.0	0.0	0.0
Rob	0.0	0.0	0.0	0.0	3.0	4.0	0.0	1.0	0.0
Mary	0.0	0.0	0.0	1.0	0.0	0.0	0.0	0.0	0.0
Steph	0.0	0.0	0.0	0.0	0.0	0.0	1.0	0.0	0.0
Carol	0.0	0.0	0.0	0.0	0.0	0.0	0.0	1.0	0.0

Shortest Path(s) from node Thomas to node Andy

- * Thomas Andy

Shortest Path(s) from node Thomas to node Helen

- * Thomas Andy Helen

Shortest Path(s) from node Thomas to node Stephen

- * Thomas Andy Carol Stephen

Shortest Path(s) from node Thomas to node Carol

- * Thomas Andy Carol

Shortest Path(s) from node Helen to node Andy

- * Helen Andy

Shortest Path(s) from node Helen to node Stephen

- * Helen Andy Carol Stephen

Shortest Path(s) from node Helen to node Carol

- * Helen Andy Carol

Shortest Path(s) from node Rob to node Andy

- * Rob Stephen Carol Andy

23 - random - Agna 2 beta

1	1	2	3	4	5	6	7	8
1	0.0	0.0	0.0	0.0	0.0	0.0	0.0	0.0
2	0.0	0.0	2.0	2.0	2.0	0.0	0.0	0.0
3	0.0	2.0	0.0	2.0	2.0	0.0	0.0	0.0
4	0.0	2.0	2.0	0.0	2.0	0.0	0.0	0.0
5	0.0	2.0	2.0	2.0	0.0	0.0	0.0	0.0
6	0.0	0.0	0.0	0.0	0.0	0.0	0.0	0.0
7	0.0	0.0	0.0	0.0	0.0	1.0	0.0	0.0
8	0.0	0.0	0.0	0.0	0.0	0.0	1.0	0.0

Statistics

Minimum	0.045454547
Maximum	1.8636364
Mean	0.99209505
Variance	0.33915293
Standard Deviance	0.5823684
Absolute Entropy	2.94479
Maximum Entropy	3.1354942
Relative Entropy (%)	6.082114

Last Modified

2006-12-18 20:11:33

Name	aiSee
URL	http://www.aisee.com/
Description	<p>Brief description: aiSee is a tool that automatically calculates a customizable layout of graphs specified in GDL (Graph Description Language). This layout is then displayed, and can be printed or interactively explored.</p> <p>Detailed description:</p>

Product Version/Status	2.2.11	
Context		
Main Functionalities	<ul style="list-style-type: none"> Automated Layout Graph Manipulation Graph Viewing 	Comments:
Domain	<ul style="list-style-type: none"> Any 	Comments:
Network Representation		
Links	<ul style="list-style-type: none"> Coloured Labelled Pre-Defined Attributes (see comments) 	Comments: Edge Attributes: anchor arrowcolor, backarrowcolor arrowsize, backarrowsize arrowstyle, backarrowstyle class colour fontname horizontal_order label linestyle priority sourcename targetname textcolor thickness Node Attributes: bordercolor borderstyle borderwidth color focus fontname height horizontal_order iconfile importance info1, info2, info3 label loc scaling shape shrink, stretch textcolor textmode title vertical_order width
Nodes	<ul style="list-style-type: none"> Coloured Labelled Pre-Defined Attributes (see comments) Symbol 	
Layout Algorithms	<ul style="list-style-type: none"> Force-Directed Hierarchical Orthogonal Spring Tree 	Comments: Nested graphs are supported
Dimensionality	<ul style="list-style-type: none"> 2D 	Comments:
Visual Enhancements		
Visual Enhancements	<ul style="list-style-type: none"> Animation/Video Distortion 	Comments: aiSee employs two different animation concepts. First, some internal layout calculations can be animated under the control of some options. Second, the entire aiSee tool can be used as an animation handler which animates a sequence of graph specifications. Cartesian and polar fish-eye views.

User Interaction		
<u>User Interaction</u>	<ul style="list-style-type: none"> • Add/Delete • GUI • Pan • Select • Zoom 	Comments:
Deployment		
	<p>Type:</p> <ul style="list-style-type: none"> • Standalone Tool 	<p>OS:</p> <ul style="list-style-type: none"> • Linux • Mac OS X • Solaris • Windows
<u>Interoperability</u>	<p>File export formats: GDL, SVG, PNG, HTML, and PS.</p> <p>aiSee can be easily integrated into and intercommunicate with other applications. The Windows version communicates over a Dynamic Data Exchange (DDE) channel, the Unix versions use user signals.</p>	
<u>Scalability</u>	<p>Max Nodes: Unlimited</p> <p>Max Links: Unlimited</p>	Comments:
	<p>Hardware:</p>	<p>Users:</p> <ul style="list-style-type: none"> • Single <p>Availability:</p> <ul style="list-style-type: none"> • Commercially Available • Freeware
<u>Cost</u>	Free - For noncommercial use	<p>Comments:</p> <p>Non-commercial users can get a license key that extends the usage period of the trial version until 14 February 2007</p> <p>aiSee Professional: \$621 aiSee Light: \$486 aiSee Academic: \$292</p> <p>see http://www.asee.com/shop/ for other pricing options.</p>

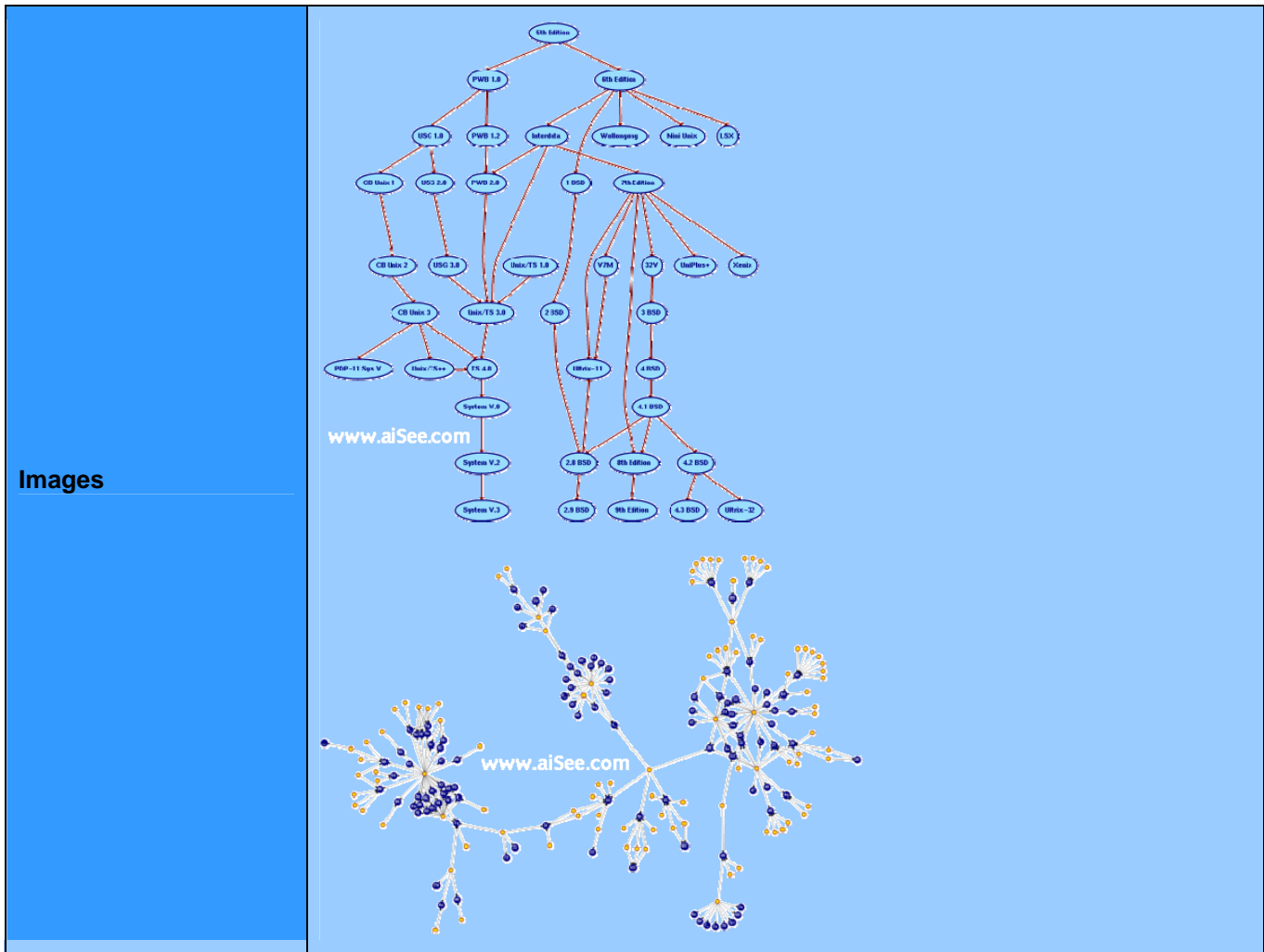

Last Modified 2006-12-18 23:27:54

Name	AlgoCOMs DIAGRAM	
URL	http://www.algorithmic-solutions.com/enalgorithmsdiagram.htm	
Description	<p>Brief description: An AlgoCOMsDiagram object provides access to the layout algorithms of the AGD library. It can be used for drawing planar and non-planar graphs. The algorithms can be accessed from any programming environment which supports COM-technology.</p> <p>Detailed description:</p>	
Context		
Main Functionalities	<ul style="list-style-type: none"> Automated Layout 	Comments:
Domain	<ul style="list-style-type: none"> Any 	Comments:
Network Representation		

<u>Layout Algorithms</u>	<ul style="list-style-type: none"> • Clustered • Grid • Hierarchical (Sugiyama) • Orthogonal • Planar • Planar:Convex • Planar:FPP • Planar:Schnyder • Spring (Tutte) • Spring FR • Tree • Tree:Walker 	Comments:
<u>Dimensionality</u>	<ul style="list-style-type: none"> • 2D 	Comments:
Deployment		
	<p><u>Type:</u></p> <ul style="list-style-type: none"> • Components for tool building 	<p><u>OS:</u></p> <ul style="list-style-type: none"> • Windows • Windows 2000 • Windows 2003 • Windows NT • Windows XP
<u>Extensibility</u>	<ul style="list-style-type: none"> • COM 	<p>Comments: AlgoCOMs Network can be used by programming language such as Java, C #, Delphi and Visual basic. AlgoCOMs Network also supports Visual Basic for Applications (VBA).</p>
	<u>Hardware:</u>	<u>Users:</u>
		<u>Availability:</u> <ul style="list-style-type: none"> • Commercially Available
<u>Cost</u>	\$1001 - \$5000	Comments:
Last Modified		
2006-12-10 16:39:16		

Name	AlgoCOMs NETWORK
URL	http://www.algorithmic-solutions.com/enalgoconsnetwork.htm
Description	<p>Brief description: An AlgoCOMsNetwork object stores a graph and provides access to almost all graph algorithms of the LEDA library, like for example computing shortest paths, flows or matchings. The algorithms can be used from any programming language which supports COM-technology.</p>

	Detailed description:	
Context		
<u>Main Functionalities</u>	<ul style="list-style-type: none"> • Network Analysis 	Comments:
<u>Domain</u>	<ul style="list-style-type: none"> • Any 	Comments:
Analysis		
<u>Network Analysis</u>	<ul style="list-style-type: none"> • Centrality:Graph • Connection:All Pairs Shortest Path • Connection:Connectivity • Connection:Distance • Connection:Flow • Connection:Node Connectivity • Connection:Path • Connection:Shortest Path • Graph Structure • Traversal:Breadth First Search 	Comments:
Deployment		
	<p><u>Type:</u></p> <ul style="list-style-type: none"> • Components for tool building 	<p><u>OS:</u></p> <ul style="list-style-type: none"> • Windows • Windows 2000 • Windows 2003 • Windows NT • Windows XP
<u>Extensibility</u>	<ul style="list-style-type: none"> • COM 	<p>Comments:</p> <p>AlgoCOMs Network can be used by programming language such as Java, C #, Delphi and Visual basic.</p> <p>AlgoCOMs Network also supports Visual Basic for Applications (VBA).</p>
	<u>Hardware:</u>	<p><u>Users:</u></p> <p><u>Availability:</u></p> <ul style="list-style-type: none"> • Commercially Available
<u>Cost</u>	\$101 - \$1000	Comments:
Last Modified		
2006-12-10 16:39:16		

Name	Amerigo for HP Openview	
URL	http://www.tavve.com/dynamic.asp?id=41	
Description	<p>Brief description: Amerigo enables network administrators to build and populate ovw maps based on attributes such as device type, vendor, agent, or location, and then publish these maps to network operators.</p> <p>Detailed description:</p>	
Product Version/Status	2.2 as of 06/10/28 (Released 05/08/10)	
Context		
Main Functionalities	<ul style="list-style-type: none"> Automated Layout 	Comments:
Network Representation		
Dimensionality	<ul style="list-style-type: none"> 2D Geospatial 	Comments:
Deployment		
	<p>Type:</p> <ul style="list-style-type: none"> Standalone Tool 	<p>OS:</p> <ul style="list-style-type: none"> HP-UX Solaris Windows 2000 Windows NT
OS Comments/Dependencies	<p>HP-UX 11 or later Solaris 2.6 or later</p> <p>Dependencies: HP OpenView Network Node Manager 6.1 or later</p>	
	Hardware:	<p>Users:</p> <p>Availability:</p> <ul style="list-style-type: none"> Commercially Available

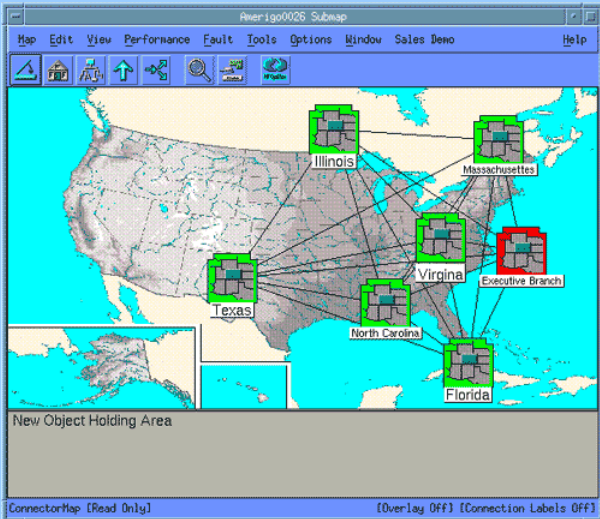
<p>Images</p>	
<p>Last Modified</p>	<p>2006-12-10 16:39:16</p>

<p>Name</p>	<p>Analyst's Notebook</p>	
<p>URL</p>	<p>http://www.i2.co.uk/Products/Analysts_Notebook/default.asp</p>	
<p>Description</p>	<p>Brief description: Analyst's Notebook provides an environment for effective link and timeline analysis. It is used worldwide by over 1500 organizations and is an essential visualisation application.</p> <p>Detailed description: Provides timeline, transaction, and link visual analysis.</p>	
<p>Product Version/Status</p>	<p>Analyst's Notebook 6</p>	
<p>Context</p>		
<p>Main Functionalities</p>	<ul style="list-style-type: none"> Automated Layout Graph Viewing Network Analysis 	<p>Comments:</p>
<p>Domain</p>	<ul style="list-style-type: none"> Any 	<p>Comments:</p>
<p>Network Representation</p>		
<p>Links</p>	<ul style="list-style-type: none"> User Defined 	<p>Comments: Any JAVA data type can be used for link/node attributes</p>
<p>Nodes</p>	<ul style="list-style-type: none"> User Defined 	
<p>Dimensionality</p>	<ul style="list-style-type: none"> 2D Geospatial Temporal 	<p>Comments:</p>
<p>Deployment</p>		

	<p>Type:</p> <ul style="list-style-type: none"> Standalone Tool <p>OS:</p> <ul style="list-style-type: none"> Windows Windows 2000 Windows XP
OS Comments/Dependencies	<p>Windows 2000 Professional SP3 and SP4 Windows XP Professional SP1 and SP2</p> <p>Requires IE6 and Microsoft .NET Framework</p>
Interoperability	<p>i2 Analyst's Notebook Development Kit http://www.i2.co.uk/Products/Analysts_Notebook/ANDK/default.asp</p> <p>Enables developers to:</p> <ul style="list-style-type: none"> -Create separate client applications that integrate with i2 Analyst's Notebook. -Extend the functionality of i2 Analyst's Notebook by writing plug-in software. -Use the i2 Analyst's Notebook component controls to build entirely new applications.
	<p>Hardware:</p> <p>Users:</p> <ul style="list-style-type: none"> Multiple Networked <p>Availability:</p> <ul style="list-style-type: none"> Commercially Available

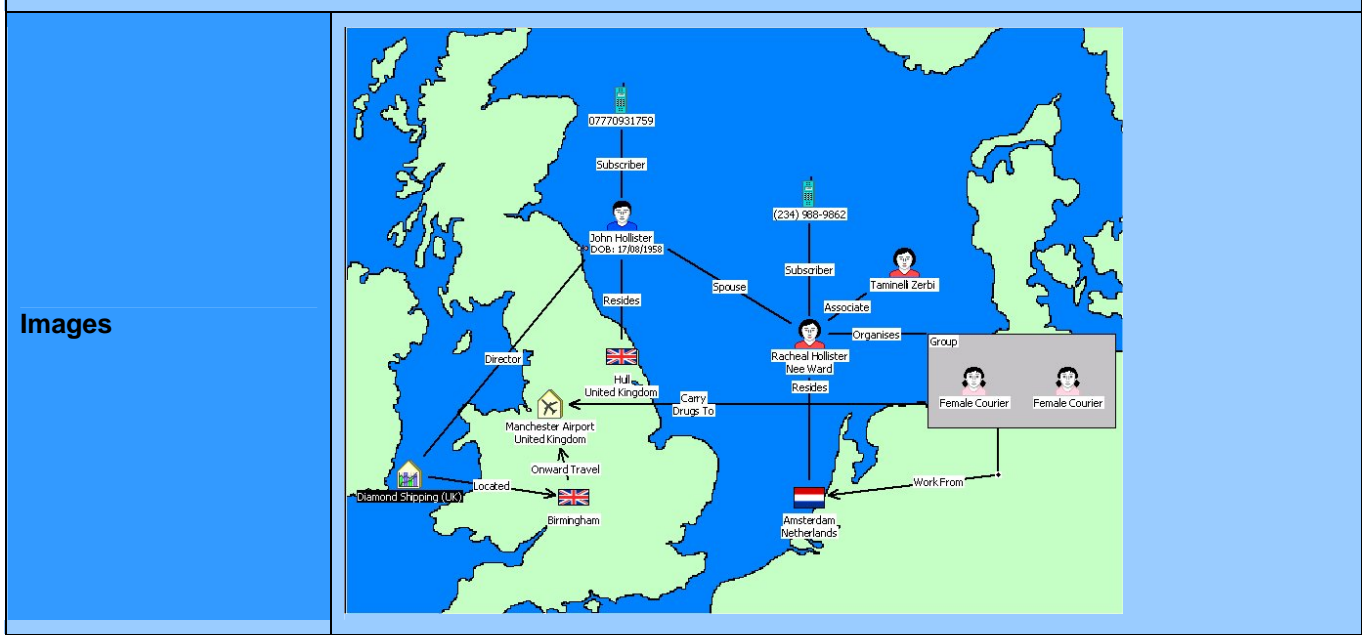

Last Modified	2006-12-18 20:46:50
----------------------	---------------------

Name	Animated Exploration of Dynamic Graphs with Radial Layout
URL	http://bailando.sims.berkeley.edu/papers/infovis01.htm
Description	Brief description:

	<p>A research paper describing an animation technique for interactively exploring graphs.</p> <p>Detailed description: From Abstract: We describe a new animation technique for supporting interactive exploration of a graph. We use the well-known radial tree layout method, in which the view is determined by the selection of a focus node. Our main contribution is a method for animating the transition to a new layout when a new focus node is selected. In order to keep the transition easy to follow, the animation linearly interpolates the polar coordinates of the nodes, while enforcing ordering and orientation constraints. We apply this technique to visualizations of social networks and of the Gnutella file-sharing network, and discuss the results from our informal usability tests.</p>
--	--

Context		
----------------	--	--

<u>Main Functionalities</u>	<ul style="list-style-type: none"> • Automated Layout • Graph Manipulation • Graph Viewing 	Comments:
<u>Domain</u>	<ul style="list-style-type: none"> • Any • Social Networks 	Comments:

Network Representation		
-------------------------------	--	--

<u>Links</u>		Comments:
<u>Nodes</u>	<ul style="list-style-type: none"> • Labelled 	
<u>Layout Algorithms</u>	<ul style="list-style-type: none"> • Radial Tree 	Comments:

Visual Enhancements		
----------------------------	--	--

<u>Visual Enhancements</u>	<ul style="list-style-type: none"> • Animation/Video 	Comments:
----------------------------	---	------------------

Deployment		
-------------------	--	--

<u>Scalability</u>	<p>Max Nodes: 101-1000</p> <p>Max Links: 101-1000</p>	Comments:
--------------------	---	------------------

--	--	--

Images

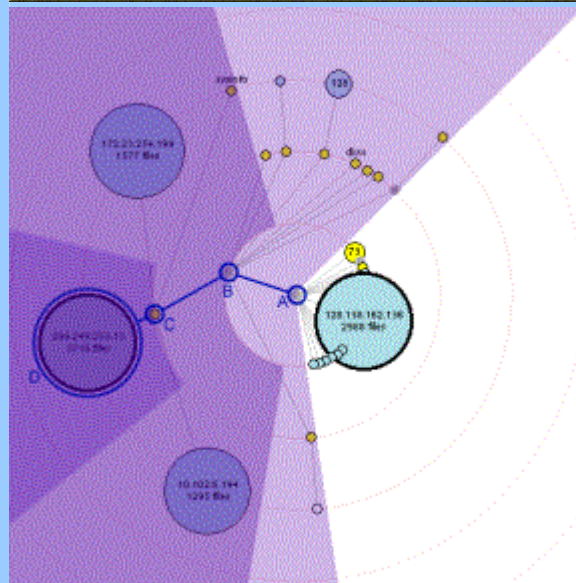
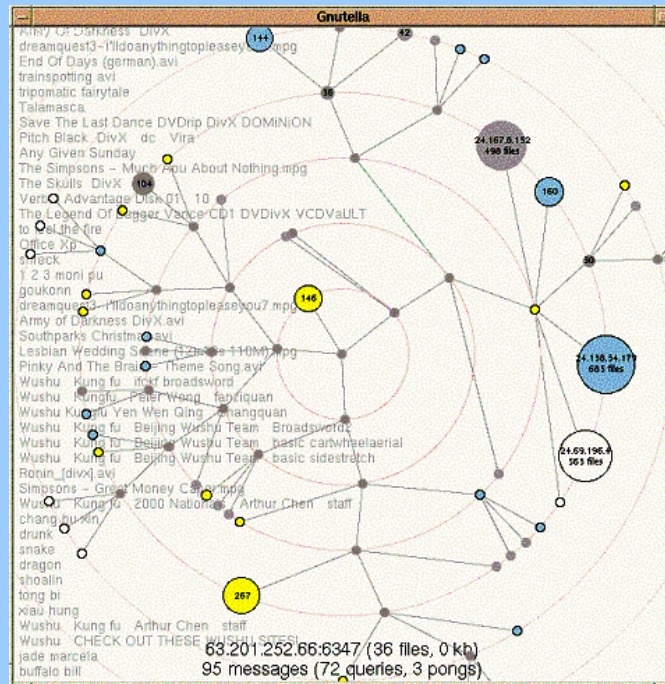

Last Modified

2006-12-10 16:39:16

Name

Ask-Graphview

Description

Brief description:

A Large Scale Graph Visualization System

Detailed description:

We describe ASK-GraphView, a node-link-based graph visualization system that allows clustering and interactive navigation of large graphs, ranging in size up to 16 million edges. The system uses a scalable architecture and a series of increasingly sophisticated clustering algorithms to construct a hierarchy on an arbitrary, weighted

	undirected input graph. By lowering the interactivity requirements we can scale to substantially bigger graphs. The user is allowed to navigate this hierarchy in a top down manner by interactively expanding individual clusters. ASK-GraphView also provides facilities for filtering and coloring, annotation and cluster labeling.	
Context		
<u>Main Functionalities</u>	<ul style="list-style-type: none"> Automated Layout Graph Manipulation Graph Viewing 	Comments:
<u>Domain</u>	<ul style="list-style-type: none"> Any 	Comments:
Network Representation		
<u>Links</u>	<ul style="list-style-type: none"> Coloured 	Comments:
<u>Nodes</u>	<ul style="list-style-type: none"> Coloured Labelled 	
<u>Layout Algorithms</u>	<ul style="list-style-type: none"> Clustered 	Comments:
<u>Dimensionality</u>	<ul style="list-style-type: none"> 3D 	Comments:
Deployment		
	<u>Type:</u> <ul style="list-style-type: none"> Standalone Tool 	<u>OS:</u>
<u>Scalability</u>	Max Nodes: Unlimited Max Links: Unlimited	Comments:
	<u>Hardware:</u>	<u>Users:</u>
		<u>Availability:</u> <ul style="list-style-type: none"> In-house Use Research Prototype

<p>Images</p>	
<p>References</p>	<p>See Paper ASK-Graphview3.pdf - "ASK-GraphView : A Large Scale Graph Visualization System"</p>
<p>Last Modified</p>	<p>2006-12-17 18:36:13</p>

<p>Name</p>	<p>big:eye</p>
<p>URL</p>	<p>http://www.cbr.com.tr/system_man.htm</p>
<p>Description</p>	<p>Brief description: big:eye is a network management tool with auto network discovery. big:eye also allows the user to create topology maps.</p> <p>Detailed description: Main features:</p> <ul style="list-style-type: none"> ›Maps(AutoDiscovery) ›Business Views ›Monitoring ›Fault Management ›Remote Control ›Hardware/Software Inventory management for Windows ›Inventory Change management for Windows ›Software distribution ›Web based reports ›Performance Monitoring ›CISCO device monitoring ›MOTOROLA device monitoring

	<ul style="list-style-type: none"> ›SNMP Device monitoring ›Client-Server Architecture ›Network printer monitoring ›Windows Based Policy Management ›Syslog ›SNMP Trap Receiver 	
Context		
<u>Main Functionalities</u>	<ul style="list-style-type: none"> • Graph Manipulation • Graph Viewing • Network managment/discovery 	Comments:
<u>Domain</u>	<ul style="list-style-type: none"> • Computer Networks 	Comments:
	<u>User Role:</u>	<u>Activity:</u> <ul style="list-style-type: none"> • Monitor • Track
Network Representation		
<u>Links</u>		Comments:
<u>Nodes</u>	<ul style="list-style-type: none"> • Labelled 	
<u>Dimensionality</u>	<ul style="list-style-type: none"> • 2D 	Comments:
Analysis		
<u>Visual Abstraction</u>	<ul style="list-style-type: none"> • Chart:Bar • Chart:Line • Chart:Pie 	Comments: Used for network traffic statistics (daily, weekly, monthly, yearly, or custom time periods available for graphing). Bar and pie charts available for visualizing the standard RMON statistics. Any statistics collected by the server can be graphed.
User Interaction		
<u>User Interaction</u>	<ul style="list-style-type: none"> • Add/Delete • Cut & Paste • Drag & Drop • GUI • Undo/Redo • Web/CGI • Zoom 	Comments: Web based reports.
Deployment		
	<u>Type:</u> <ul style="list-style-type: none"> • Standalone Tool 	<u>OS:</u> <ul style="list-style-type: none"> • Windows • Windows 2000 • Windows 2003

	<ul style="list-style-type: none"> • Windows NT • Windows XP 						
	<table border="0" style="width: 100%;"> <tr> <td style="width: 33%;"><u>Hardware:</u></td> <td style="width: 33%;"><u>Users:</u></td> <td style="width: 33%;"><u>Availability:</u></td> </tr> <tr> <td></td> <td> <ul style="list-style-type: none"> • Multiple • Networked </td> <td> <ul style="list-style-type: none"> • Commercially Available </td> </tr> </table>	<u>Hardware:</u>	<u>Users:</u>	<u>Availability:</u>		<ul style="list-style-type: none"> • Multiple • Networked 	<ul style="list-style-type: none"> • Commercially Available
<u>Hardware:</u>	<u>Users:</u>	<u>Availability:</u>					
	<ul style="list-style-type: none"> • Multiple • Networked 	<ul style="list-style-type: none"> • Commercially Available 					



Images	
--------	--

Last Modified	2006-12-18 19:03:55
----------------------	---------------------

Name	Blanche
URL	http://www.spcomm.uiuc.edu/teclab/blanche/pages/
Description	<p>Brief description: Blanche is a program designed to create and execute computational models of network behaviour.</p> <p>Detailed description: Blanche is intended to be used by researchers who wish to formulate a hypothesis of how a particular network (of people, organizations, or anything else) functions, and then evaluate the hypothesis by simulating the network and examining the results.</p>
<u>Product Version/Status</u>	Blanche 4.8.1 Currently supported. Blanche is still under heavy development and there are still some bugs within it.

Context		
<u>Main Functionalities</u>	<ul style="list-style-type: none"> Graph Viewing Network Analysis 	Comments:
Network Representation		
<u>Type</u>	<ul style="list-style-type: none"> Directed Undirected 	
<u>Links</u>	<ul style="list-style-type: none"> User Defined 	Comments: Any JAVA data type can be used for link/node attributes
<u>Nodes</u>	<ul style="list-style-type: none"> User Defined 	
<u>Dimensionality</u>	<ul style="list-style-type: none"> 2D Temporal 	Comments:
Analysis		
<u>Network Analysis</u>		Comments: Blanche is able to graph many aspects of a model with respect to time in order to visually demonstrate the evolution of the network over time. Blanche also offers a dynamic Visualizer that spatially represents links between nodes.
Deployment		
	<u>Type:</u>	<u>OS:</u> <ul style="list-style-type: none"> Windows
<u>Extensibility</u>		Comments: Output as text files, UCINET DL or Krackplot KP files.
<u>Interoperability</u>	Blanche allows data to be passed between other simulation programs and Blanche itself.	

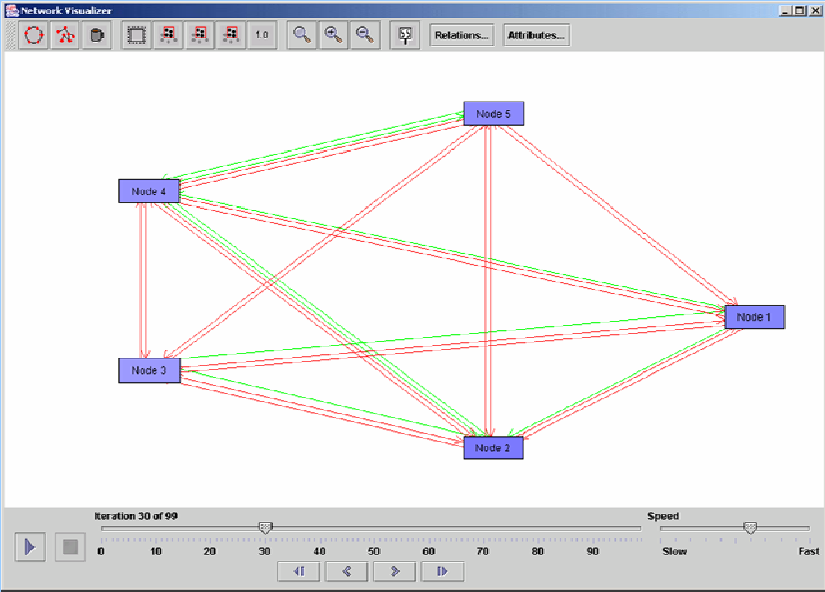
<p>Images</p>	
<p>Last Modified</p>	<p>2006-12-10 16:39:16</p>

<p>Name</p>	<p>BMC Topology Discovery</p>	
<p>URL</p>	<p>http://www.bmc.com/products/proddocview/0,2832,19052_0_31415203_119509,00.html</p>	
<p>Description</p>	<p>Brief description: Topology discovery provides mapping of components within the IT environment.</p> <p>Detailed description: Key Features & Benefits</p> <ul style="list-style-type: none"> * Integrates with the BMC® Atrium™ CMDB or exports to custom or third-party CMDBs * Provides an up-to-date view of dependencies and relationships that make up IT and business services * Enables asset, incident and problem, change and configuration, and service level management * Enables IT to resolve the most urgent incidents faster by impact modeling to associate and prioritize incidents by business service criticality * Extensions for SAP, Siebel, J2EE, VMWare, Web Services, Business Processes, Mainframe, Storage, and more * Uses Universal Application Discovery (UAD) to find apps and dependencies based on ports and process mapping with patent-pending algorithms * Embeds knowledge base of 10,000+ processes and applications mapping with a UAD; allows the user to enrich the knowledge base with their applications 	
<p>Context</p>		
<p><u>Main Functionalities</u></p>	<ul style="list-style-type: none"> • Network management/discovery 	<p>Comments:</p>
<p><u>Domain</u></p>	<ul style="list-style-type: none"> • Computer Networks 	<p>Comments:</p>

	<u>User Role:</u>	<u>Activity:</u>
	• GUI	<ul style="list-style-type: none"> • Monitor • Track

User Interaction

<u>User Interaction</u>	• GUI	<u>Comments:</u>
-------------------------	-------	------------------

Deployment

	<u>Type:</u>	<u>OS:</u>
	• Standalone Tool	

<u>Interoperability</u>	<p>Extensions for SAP, Siebel, J2EE, VMWare, Web Services, Business Processes, Mainframe, Storage, and more</p> <p>Various export capabilities, including CSV, Excel, HTML, PNG, and SVG Visio 2003</p>
-------------------------	---

	<u>Hardware:</u>	<u>Users:</u>	<u>Availability:</u>
			<ul style="list-style-type: none"> • Commercially Available

Images

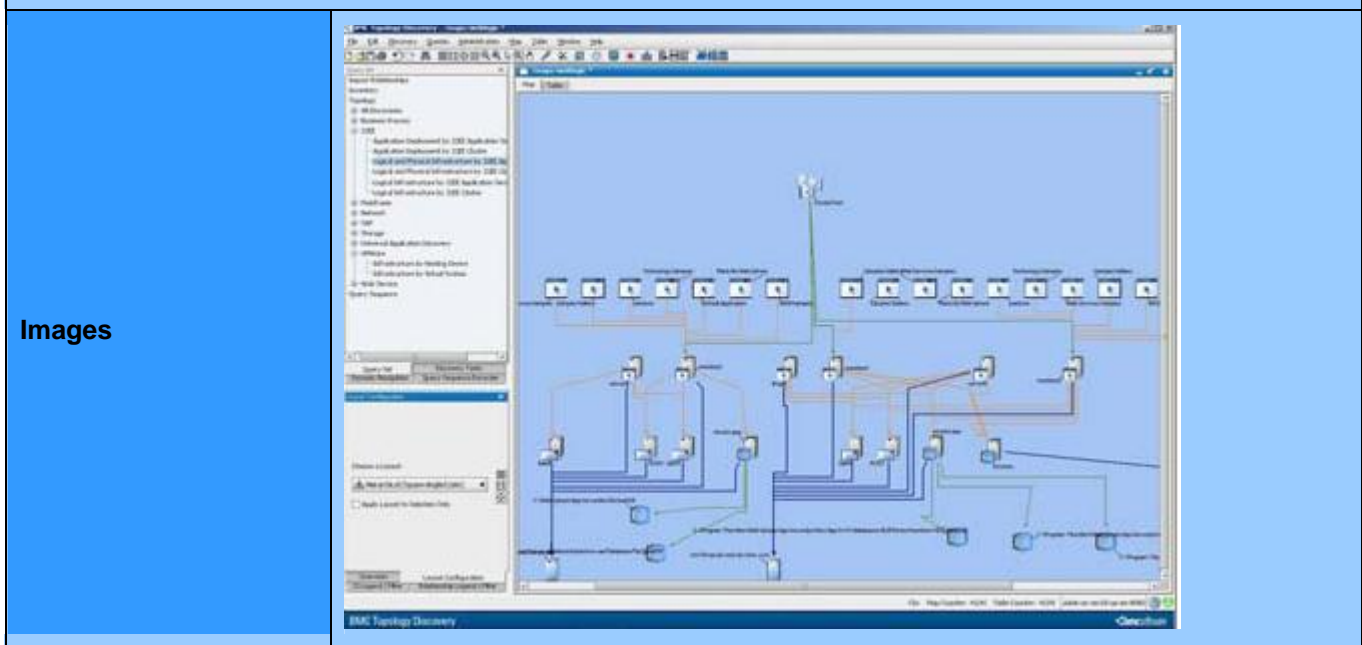

Last Modified	2006-12-18 19:42:56
----------------------	---------------------

Name	Boost Graph Library
-------------	----------------------------

URL	http://www.boost.org/libs/graph/doc/table_of_contents.html
------------	---

Description	Brief description: A general C++ library intended to be useful across a broad spectrum of applications. Among them many feature and algorithms, boost contains algorithms for graph layout and analysis. Detailed description:	
Context		
<u>Main Functionalities</u>	<ul style="list-style-type: none"> Automated Layout Graph Manipulation Graph Viewing 	Comments:
<u>Domain</u>	<ul style="list-style-type: none"> Any 	Comments:
Network Representation		
<u>Type</u>	<ul style="list-style-type: none"> Directed Undirected 	
<u>Links</u>	<ul style="list-style-type: none"> Weighted 	Comments:
<u>Nodes</u>	<ul style="list-style-type: none"> Weighted 	
<u>Layout Algorithms</u>	<ul style="list-style-type: none"> Circular Clustered Force-Directed Random Spring Spring FR Spring KK 	Comments:
Analysis		
<u>General Analysis</u>	<ul style="list-style-type: none"> Data Transformation:Direction 	Comments:
<u>Network Analysis</u>	<ul style="list-style-type: none"> Centrality Centrality:Betweenness Clustering Cohesion:Bi-Component Connection:All Pairs Shortest Path Connection:Minimal Spanning Tree Connection:Shortest Path Topological Sort Traversal:Breadth First Search Traversal:Depth First Search 	Comments:
Deployment		
	<u>Type:</u> <ul style="list-style-type: none"> Components for tool building Open Source 	<u>OS:</u> <ul style="list-style-type: none"> Multi-Platform

Extensibility	<ul style="list-style-type: none"> • C++ 	Comments:
Interoperability	import/export graphviz DOT format	
	Hardware:	Users:
		Availability: <ul style="list-style-type: none"> • Freeware • In Development • In Use
Cost	Free	Comments: Boost Software License http://www.boost.org/more/license_info.html
Last Modified	2006-12-14 20:36:44	

Name	CCVisu
URL	http://mtc.epfl.ch/~beyer/CCVisu/
Description	<p>Brief description: A tool for co-change visualization and General force-directed graph layout</p> <p>Detailed description: - General force-directed graph layout, in particular for clustering layout.</p> <p>The tool CCVisu is a light-weight tool for force-directed graph layout. The tool reads the input graph from a file in RSF (Rigi Standard Format), which is a standard text format for relations. The layout of the graph is computed using standard techniques from force-directed layout. The tool supports several energy models, which can be selected by setting command line parameters. The weighted edge-repulsion LinLog energy model (default) is good for producing layouts that fulfill certain clustering criteria. The Fruchterman Reingold energy model is good for producing layouts that fulfill certain esthetic criteria like uniform edge length. CCVisu stores the resulting layout in certain text file formats such as VRML or SVG, or it displays the layout on the screen.</p> <p>- Co-Change Visualization.</p> <p>Clustering layouts of software systems combine two important aspects: they reveal groups of related artifacts of the software system, and they produce a visualization of the results that is easy to understand. Co-change visualization is a lightweight method for computing clustering layouts of software systems for which the change history is available. The tool implementation CCVisu extracts the co-change graph from a CVS version repository, and computes a clustering layout based on energy models, which positions the artifacts of the software system in a two- or three-dimensional space. Two artifacts are positioned closed together in the layout if they were often changed together. The tool is designed as a framework, easy to use, and easy to integrate into reengineering environments; several formats for data interchange are already implemented. The graph layout is currently provided in VRML and SVG format, in a standard text format, or directly drawn on the screen.</p>

Product Version/Status	2.0 (2006-11-25)	
Context		
Main Functionalities	<ul style="list-style-type: none"> Automated Layout 	Comments:
Domain	<ul style="list-style-type: none"> Any 	Comments:
Network Representation		
Layout Algorithms	<ul style="list-style-type: none"> Clustered Force-Directed Spring Spring FR 	Comments:
Dimensionality	<ul style="list-style-type: none"> 2D 	Comments:
Deployment		
	Type: <ul style="list-style-type: none"> Open Source Standalone Tool 	OS: <ul style="list-style-type: none"> Multi-Platform (JAVA)
Extensibility	<ul style="list-style-type: none"> JAVA 	Comments:
Interoperability	CCVisu can export layouts to VRML and SVG file formats. CCVisu will read CVS, RSF (Graph), and LAY (layout) files.	
	Hardware:	Users: Availability: <ul style="list-style-type: none"> Freeware In Development Research Prototype
Cost	Free	Comments: Distributed under the GNU Lesser General Public License (LGPL). http://www.gnu.org/licenses/lgpl.html
Last Modified		
2006-12-14 20:39:03		

Name	cheops-ng
URL	http://cheops-ng.sourceforge.net/
Description	Brief description: Cheops-ng is a Network management tool for mapping and monitoring your network. It has host/network discovery functionality as well as OS detection of hosts. Cheops-ng has the ability to probe hosts to see what services they are running.

	Detailed description:	
Product Version/Status	0.2.3 as of 06/10/28 (released 05/10/18)	
Context		
Main Functionalities	<ul style="list-style-type: none"> Automated Layout Network managment/discovery 	Comments:
Domain	<ul style="list-style-type: none"> Computer Networks 	Comments:
	User Role:	Activity: <ul style="list-style-type: none"> Monitor
Network Representation		
Links		Comments:
Nodes	<ul style="list-style-type: none"> Labelled Symbol 	
Dimensionality	<ul style="list-style-type: none"> 2D 	Comments:
Deployment		
	Type: <ul style="list-style-type: none"> Open Source - GPL Standalone Tool 	OS: <ul style="list-style-type: none"> FreeBSD Linux
OS Comments/ Dependencies	dependencies: gnome gnome-xml >= 1.8.0 glib >= 1.2.0 glib-devel >= 1.2.0 imlib >= 1.9.0 imlib-devel >= 1.9.0 nmap > 2.54BETA30 libpthread libgnome-devel gnome-libs-devel libpng-devel esound-devel gnomecanvas-devel libxml-devel	
	Hardware:	Users:
		Availability: <ul style="list-style-type: none"> Freeware
Cost	Free	Comments:

<p>Images</p>	
<p>Last Modified</p>	<p>2006-12-16 17:34:46</p>

<p>Name</p>	<p>ConceptDraw NetDiagrammer</p>	
<p>URL</p>	<p>http://www.conceptdraw.com/en/products/netdiagrammer/overview.php</p>	
<p>Description</p>	<p>Brief description: ConceptDraw NetDiagrammer allows you to not only draw professional network and system diagrams and schematics but also all types of UML diagrams, floor plans and office layout drawings, flowcharts and dataflow diagrams, workflow and others.</p> <p>Detailed description:</p>	
<p>Context</p>		
<p><u>Main Functionalities</u></p>	<ul style="list-style-type: none"> Automated Layout Graph Manipulation Graph Viewing 	<p>Comments:</p>
<p><u>Domain</u></p>	<ul style="list-style-type: none"> Computer Networks 	<p>Comments:</p>
<p>Network Representation</p>		
<p><u>Links</u></p>	<p>Comments:</p>	
<p><u>Nodes</u></p>	<ul style="list-style-type: none"> Symbol User Defined 	<p>Comments:</p>

Layout Algorithms		Comments: Lan Scanner Wizard - Allows you to automatically scan your local network and draw a detailed diagram of LAN. You can also specify services and resources to be included into your diagram
User Interaction		
User Interaction	<ul style="list-style-type: none"> • Grid/Ruler • Groups • GUI 	Comments:
Deployment		
	<p>Type:</p> <ul style="list-style-type: none"> • Standalone Tool 	<p>OS:</p> <ul style="list-style-type: none"> • Mac OS X • Windows • Windows 2000 • Windows 95/98/ME • Windows NT • Windows XP
OS Comments/Dependencies	Mac OS X 10.1.5	
Extensibility		Comments: Built-In Scripting Language - ConceptDraw Basic - and support for XML ConceptDraw open format, as well as for a number of other formats, provide developers with powerful means of building complex customized solutions.
Interoperability	<p>MS Visio Support. ConceptDraw NetDiagrammer supports XML for Visio, allowing you to exchange documents with MS Visio users.</p> <p>ConceptDraw NetDiagrammer imports and exports files to a large number of raster, vector, multimedia and text formats, making it easy to exchange data with other applications. Apart from most popular graphic formats, it supports AutoCAD DXF files, allows to create and edit MS PowerPoint files, export documents to PDF and HTML with hyperlinks.</p>	
	Hardware:	<p>Users:</p> <p>Availability:</p> <ul style="list-style-type: none"> • Commercially Available
Cost	\$101 - \$1000	Comments: \$299

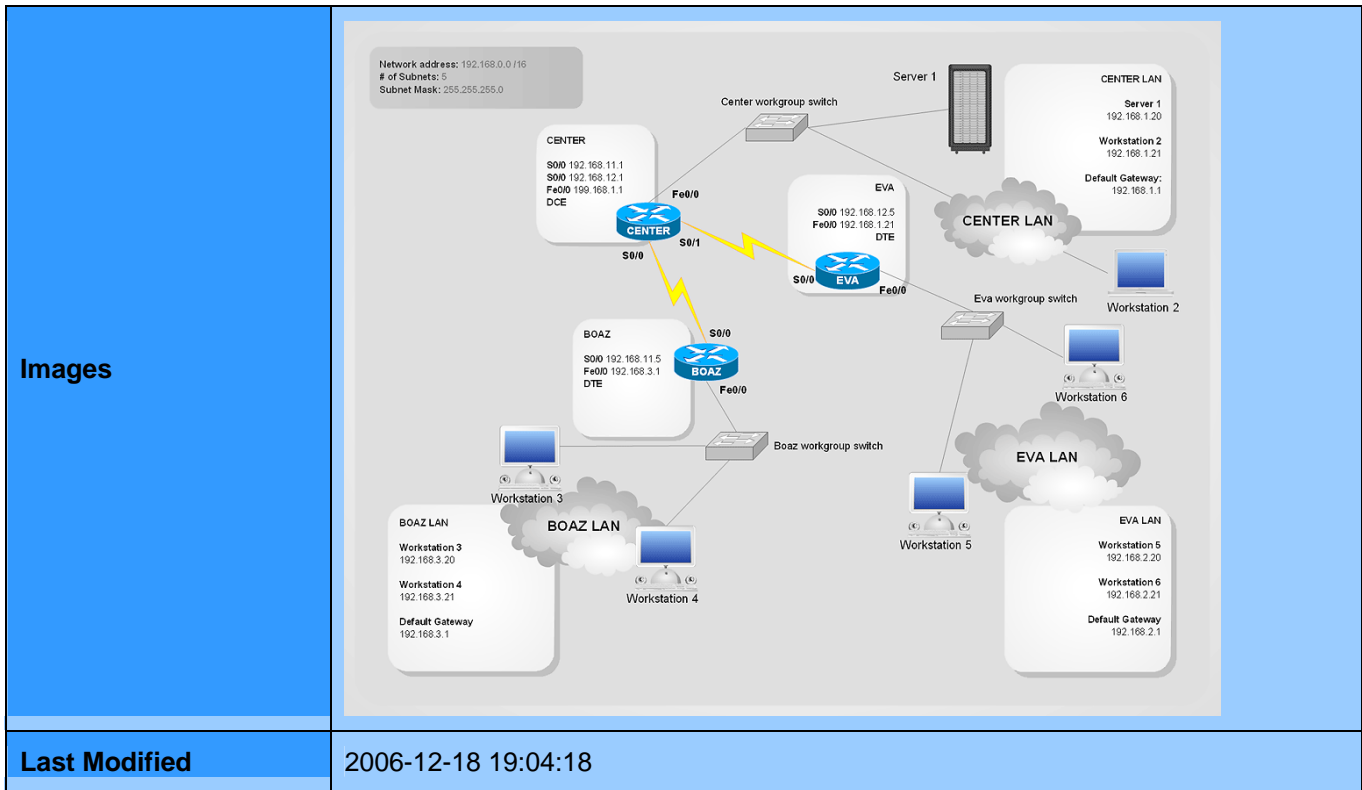

Name	Coplink	
URL	http://ai.bpa.arizona.edu/research/coplink/Visualization.htm	
Description	<p>Brief description: Coplink displays visually the relationships among data sets.</p> <p>Detailed description:</p>	
Context		
Main Functionalities	<ul style="list-style-type: none"> • Graph Viewing 	Comments: Law Enforcement - visual relationships
Domain	<ul style="list-style-type: none"> • Social Networks 	Comments: Law Enforcement
Network Representation		
Links	<ul style="list-style-type: none"> • Labelled 	Comments:
Nodes	<ul style="list-style-type: none"> • Labelled 	
Dimensionality	<ul style="list-style-type: none"> • 2D • Temporal 	Comments:
Deployment		

	Type: <ul style="list-style-type: none"> Standalone Tool 	OS: <ul style="list-style-type: none"> Multi-Platform (JAVA)
Extensibility	<ul style="list-style-type: none"> JAVA 	Comments:
Cost	unknown	Comments: Research project at The University of Arizona, in the Management Information Systems (MIS) Department, the Artificial Intelligence Lab. Used by Law Enforcement (only)?



Images

The screenshot displays the Corgent Diagram for .NET interface. On the left, there is a list of nodes with their identifiers, such as 'TIPTON, EDDIE [19760904]' and 'FORD / PK / TK / MAR / 1994'. The main area shows a network diagram where nodes are connected by lines, representing relationships. The nodes are color-coded: green for 'person', red for 'vehicle', and blue for 'organization'. The central node is 'FORD / PK / TK / MAR / 1994'. Other prominent nodes include 'TIPTON, EDDIE', 'ANTRIKIN, -', and 'TRUSILLO, MANUEL'. The interface includes a search bar, a history search section, and a legend for node types at the bottom.

Last Modified	2006-12-10 16:39:16
----------------------	---------------------

Name	Corgent Diagram for .NET
URL	http://www.corgent.com/index.aspx
Description	<p>Brief description: Corgent Diagram for .NET is a solution designed to add interactive diagramming-related functionality to Web and Client applications.</p> <p>Detailed description: Corgent Diagram for .NET is made up of 3 main parts; Diagram Editor, Diagram Host and Diagram Object Model (DOM).</p>

	<p>Diagram Editor - The editor is a complete and powerful diagramming environment that is used to create, edit and save diagram documents and templates. It includes a built-in code editor to add advanced interactivity to diagram elements.</p> <p>Diagram Host - Diagrams created with Corgent Diagram for .NET can be hosted in both desktop and web applications using different versions of the Diagram Host.</p> <p>Diagram Object Model (DOM) - The DOM is an extensive object model that encompasses all diagramming elements, enabling users to either script against diagram elements using the code editor, or program against using application code.</p>	
Product Version/Status	2.5	
Context		
Main Functionalities	<ul style="list-style-type: none"> • Automated Layout • Graph Manipulation • Graph Viewing 	Comments:
Domain	<ul style="list-style-type: none"> • Any 	Comments:
Network Representation		
Links	<ul style="list-style-type: none"> • Coloured • Labelled 	Comments: Support for annotations
Nodes	<ul style="list-style-type: none"> • Labelled • Symbol 	
Layout Algorithms	<ul style="list-style-type: none"> • Barycentric • Force-Directed • Hierarchical • OrgChart • Radial Tree • Spring • Tree 	Comments: Infrastructure for custom Layout Engines
Dimensionality	<ul style="list-style-type: none"> • 2D 	Comments:
User Interaction		
User Interaction	<ul style="list-style-type: none"> • Add/Delete • Cut & Paste • Groups • GUI • Layers • Pan • Reposition • Resize • Rotate • Select • Undo/Redo • Zoom 	Comments:

Deployment

	<p>Type:</p> <ul style="list-style-type: none"> • Components for tool building • Web-based <p>OS:</p> <ul style="list-style-type: none"> • Windows 	
OS Comments/Dependencies	full Visual Studio 2005 integration Visual Studio 2003 Support	
Extensibility	<ul style="list-style-type: none"> • .NET • C# • Visual Basic 	<p>Comments:</p> <p>The Diagram Editor, Diagram Host and Diagram Object Model (DOM) are all fully programmable via an extensive API</p>
Interoperability	Import: EMF Export: JPEG, PNG, BMP, GIF, TIFF, ICO, WMF, SVG	
	<p>Hardware:</p>	<p>Users:</p> <ul style="list-style-type: none"> • Multiple • Networked
		<p>Availability:</p> <ul style="list-style-type: none"> • Commercially Available
Cost	\$1001 - \$5000	<p>Comments:</p> <p>Retail \$2999 US</p>

Images

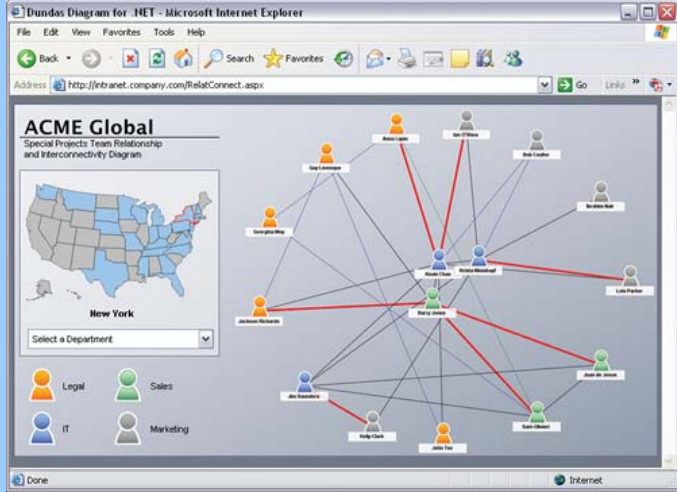
Images	
---------------	--

Last Modified	2006-12-10 16:39:16
----------------------	---------------------

Name	Daisy
URL	http://www.daisy.co.uk/daisy.html
Description	<p>Brief description:</p> <p>Daisy (Data Analysis Interactively) is multi-dimensional, analysis and visualization program that can represent any database as a series of charts</p>

	Detailed description:	
Context		
<u>Main Functionalities</u>	<ul style="list-style-type: none"> Automated Layout Graph Viewing 	Comments:
<u>Domain</u>	<ul style="list-style-type: none"> Databases 	Comments:
Network Representation		
<u>Layout Algorithms</u>	<ul style="list-style-type: none"> Daisy Chart 	Comments: In addition to the Daisy Chart, Daisy can generate several more different types of chart: <ul style="list-style-type: none"> - Boxed Histogram - Circular Histogram - Date and Time Chart - Duplicate Chart - Go-Matrix Chart - Horizontal Histogram - Pie Chart - Summary Chart - Vertical Histogram
<u>Dimensionality</u>	<ul style="list-style-type: none"> 2D 	Comments:
Deployment		
	<u>Type:</u> <ul style="list-style-type: none"> Components for tool building Standalone Tool 	<u>OS:</u> <ul style="list-style-type: none"> Windows
<u>Extensibility</u>	<ul style="list-style-type: none"> ActiveX Visual Basic 	Comments:
<u>Interoperability</u>	Daisy is fully compliant with Microsoft's ActiveX, therefore, other Windows based programs can interact with Daisy. Daisy is also available as family of OCXs (OLE Control Extension). These components can be built into other Windows based programs.	
<u>Cost</u>	\$101 - \$1000	Comments:

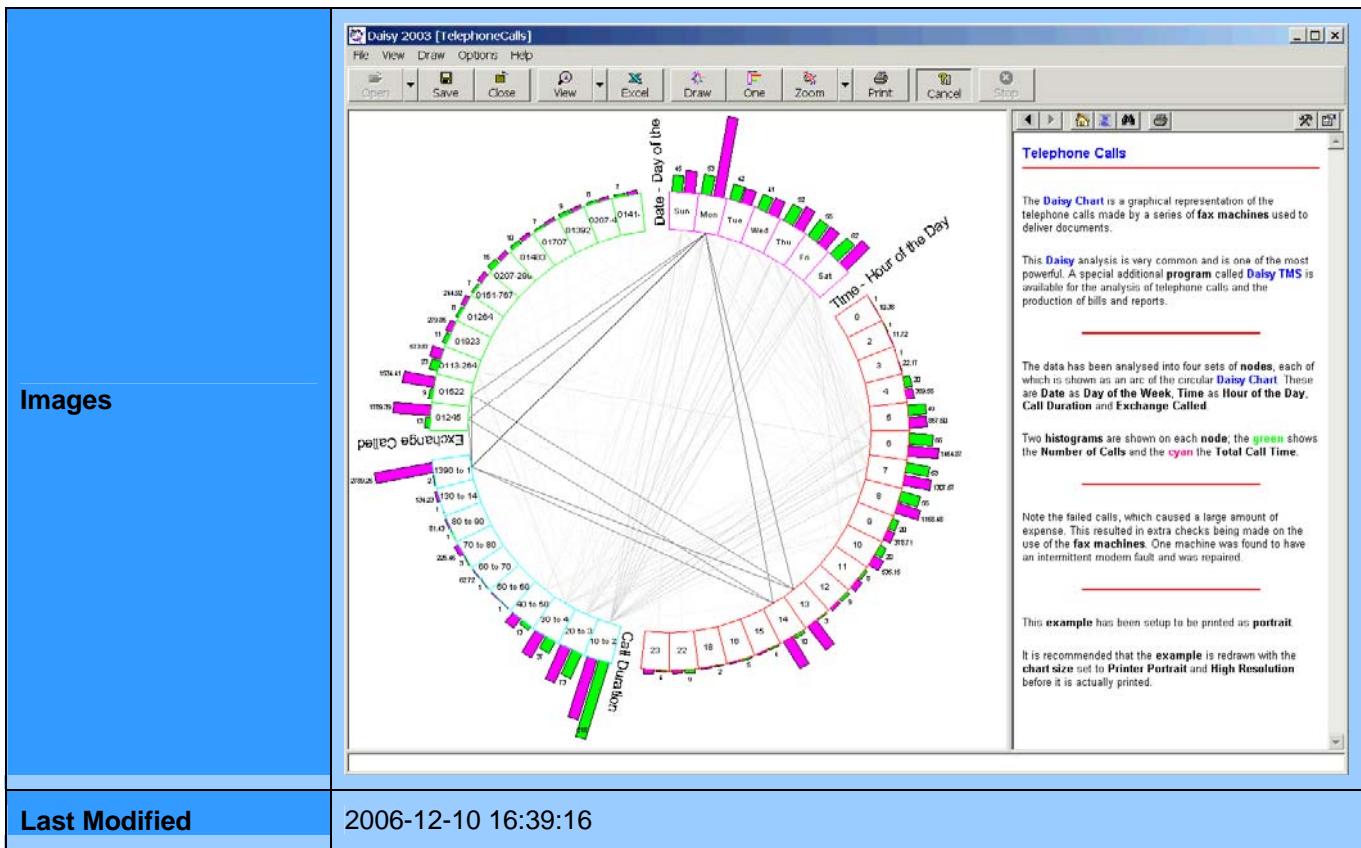

Name	DyNet	
URL	http://www.atalab.com/software/dynet/index.php	
Description	<p>Brief description: DyNet is a knowledge visualization tool which enables rapid domain analysis</p> <p>Detailed description: Data are mined from corporate databases and public data sources. Relationships between concepts and entities (i.e. firms, patents, publications) are identified using citations, descriptive terms, or textual similarities. Linkages among thousands of concepts and entities are then represented as an evolving network in time.</p>	
Context		
Main Functionalities	<ul style="list-style-type: none"> Automated Layout Graph Manipulation Graph Viewing 	Comments:
Domain	<ul style="list-style-type: none"> Any 	Comments:
Network Representation		
Type	<ul style="list-style-type: none"> Multi-Mode 	
Layout Algorithms	<ul style="list-style-type: none"> Clustered 	Comments:

		Automated generation of network representations of high-dimensional data with interactive access to underlying information
<u>Dimensionality</u>	<ul style="list-style-type: none"> • 2D • Temporal 	Comments: Emphasis on time-based data, providing the user with movies and timelines that help identify critical phases during network evolution
Visual Enhancements		
<u>Visual Enhancements</u>	<ul style="list-style-type: none"> • Animation/Video 	Comments:
User Interaction		
<u>User Interaction</u>	<ul style="list-style-type: none"> • Drill down • Filter • Focus • Groups • GUI • Zoom 	Comments:
Deployment		
	<u>Type:</u> <ul style="list-style-type: none"> • Standalone Tool 	<u>OS:</u>
	<u>Hardware:</u>	<u>Users:</u>
		<u>Availability:</u> <ul style="list-style-type: none"> • Commercially Available

Images

Last Modified 2006-12-10 16:39:16

Name	Eye of the Storm	
URL	http://www.entuity.com/products/topology-asset-navigator.html	
Description	<p>Brief description: Eye of the storm is a network management suite that provides fault, performance, and inventory management.</p> <p>Detailed description: The asset navigator automatically creates real-time 3D views of the physical and logical connections between layer two and layer three network elements and applications. Views can be based on geography, business function, or infrastructure properties.</p>	
Context		
Main Functionalities	<ul style="list-style-type: none"> Automated Layout Graph Viewing Network management/discovery 	Comments:
Domain	<ul style="list-style-type: none"> Computer Networks 	Comments:

	<u>User Role:</u> 	<u>Activity:</u> <ul style="list-style-type: none"> Monitor
Network Representation		
<u>Dimensionality</u>	<ul style="list-style-type: none"> 2D 3D Geospatial 	Comments:
User Interaction		
<u>User Interaction</u>	<ul style="list-style-type: none"> GUI Web/CGI 	Comments:
Deployment		
	<u>Type:</u> <ul style="list-style-type: none"> Standalone Tool Web-based 	<u>OS:</u>
<u>OS Comments/Dependencies</u>	IE 6.0+ JS2E 1.4.2. Java 3D 1.3.1 OpenGL (for asset navigator)	
<u>Interoperability</u>	Integrates with Visio 2000 and Visio 3000 Integration with Visio 2000 uses CSV files while integration with Visio 3000 uses XML drawing files	
	<u>Hardware:</u> <ul style="list-style-type: none"> 3D Graphics accelerator 	<u>Users:</u> <ul style="list-style-type: none"> Multiple Networked
		<u>Availability:</u>

Images

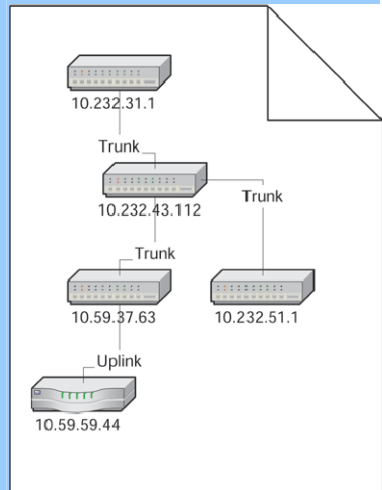
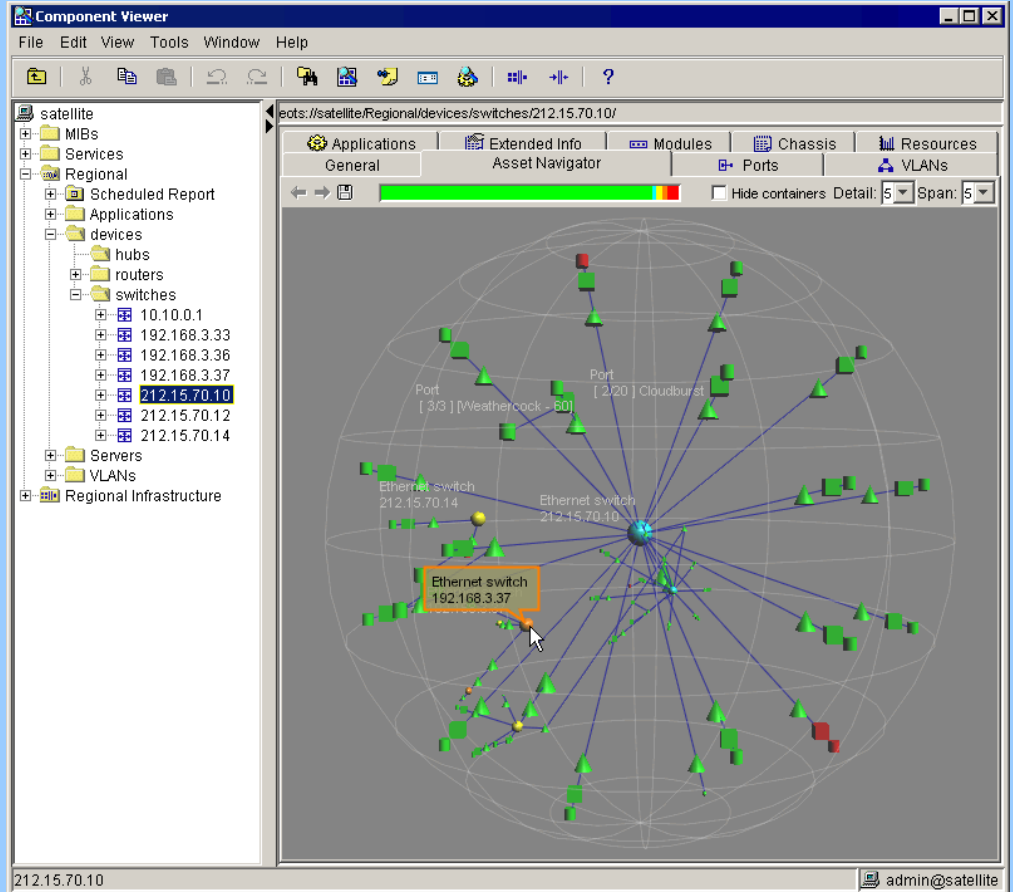

Last Modified

2006-12-18 19:04:46

Name

GDTToolkit

URL

<http://www.dia.uniroma3.it/~gdt/index.html>

Description

Brief description:
GDTToolkit (also known as GDT) is a Graph Drawing Toolkit designed to manipulate

	several types of graph, and to automatically draw them according to many different aesthetic criteria and constraints.	
	Detailed description:	
Product Version/Status	3.0 Requires LEDA	
Context		
Main Functionalities	<ul style="list-style-type: none"> Automated Layout Graph Manipulation Graph Viewing 	Comments:
Network Representation		
Type	<ul style="list-style-type: none"> Directed Undirected 	
Layout Algorithms	<ul style="list-style-type: none"> Orthogonal Planar Tree 	Comments: Users can individually enforce layout constraints on nodes and edges.
Dimensionality	<ul style="list-style-type: none"> 2D 	Comments:
Deployment		
	Type: <ul style="list-style-type: none"> Components for tool building 	OS: <ul style="list-style-type: none"> Linux Solaris Windows
Extensibility	<ul style="list-style-type: none"> C++ 	Comments:
Cost	Free - For academic use	Comments:
Last Modified		
	2006-12-10 16:39:16	

Name	GeoPlot
URL	http://www.caida.org/tools/visualization/geoplot/
Description	Brief description: GeoPlot is a light-weight java applet which allows users to create a geographical image of a data set.

	Detailed description: The applet provides the user with many options to represent the data set. Basically, GeoPlot plots a set of nodes and a set of lines that connect these nodes on an image specified by the user.	
Product Version/Status	1.0.0 (Beta) 1999-07-23	
Context		
Main Functionalities	<ul style="list-style-type: none"> Graph Viewing 	Comments:
Domain	<ul style="list-style-type: none"> Computer Networks 	Comments:
Network Representation		
Links	<ul style="list-style-type: none"> User Defined 	Comments: Color keys and size keys can be defined which can be used to determine the color and width of the nodes and lines drawn on the image. There can be multiple lines between any two nodes, as well as for a single node.
Nodes	<ul style="list-style-type: none"> User Defined 	
Dimensionality	<ul style="list-style-type: none"> 2D Geospatial 	Comments:
Deployment		
	Type: <ul style="list-style-type: none"> Components for tool building Open Source 	OS: <ul style="list-style-type: none"> Multi-Platform (JAVA)
Extensibility	<ul style="list-style-type: none"> Perl 	Comments:
Interoperability	A simple Perl API allows perl programs to invoke methods to add nodes, links, paths etc. so that the user has a higher level abstraction and does not fully require to know the applet parameter details. The html document that the GeoPlot applet requires as input can then be automatically generated.	
Cost	Free	Comments:
Last Modified		
	2006-12-10 16:39:16	

Name	GINY - Graph INTERface librARy
URL	http://csbi.sourceforge.net/
Description	Brief description: GINY is an open source JAVA library for visualizing graphs. Detailed description: GINY is an attempt at a generic interface for graph based algorithms and functions.

	In the strictest sense, GINY does not actually provide any algorithms but rather a common interface to access graph specific algorithms.	
Product Version/Status	1.1 2005-08-31	
Context		
Main Functionalities	<ul style="list-style-type: none"> Automated Layout Graph Viewing 	Comments:
Domain	<ul style="list-style-type: none"> Any Biology 	Comments:
Network Representation		
Layout Algorithms	<ul style="list-style-type: none"> Force-Directed Hierarchical (Sugiyama) Inverted Self Organising Map Spring FR Spring KK 	Comments:
Dimensionality	<ul style="list-style-type: none"> 2D 3D 	Comments:
Analysis		
Network Analysis	<ul style="list-style-type: none"> Connection:All Pairs Shortest Path 	Comments:
Deployment		
	Type: <ul style="list-style-type: none"> Components for tool building Open Source 	OS: <ul style="list-style-type: none"> Multi-Platform (JAVA)
Extensibility	<ul style="list-style-type: none"> JAVA 	Comments: Any algorithm or function can be added to the GINY framework.
	Hardware:	Users: Availability: <ul style="list-style-type: none"> Freeware In Development In Use
Cost	Free	Comments: Distributed under the GNU Lesser General Public License (LGPL). http://www.gnu.org/licenses/lgpl.html

Images

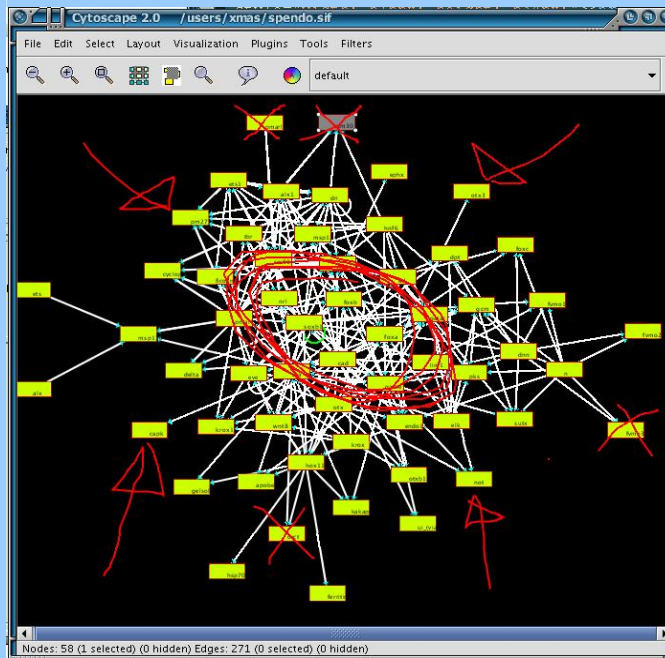
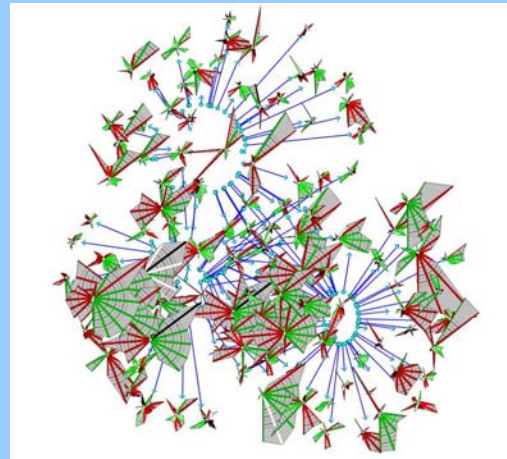
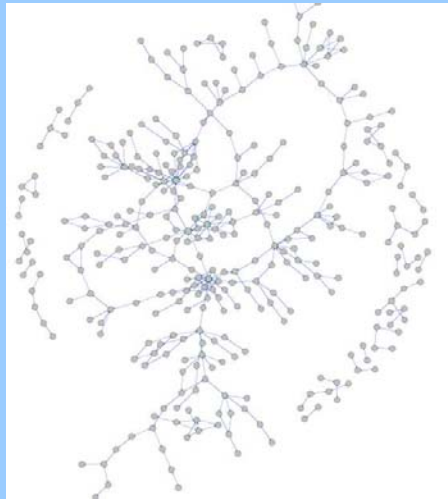

References

Whitepaper
http://csbi.sourceforge.net/white_paper.html

GINY is being incorporated into Cytoscape, and is replacing yFiles in that project.
<http://www.cytoscape.org/>

Last Modified

2006-12-15 20:04:04

Name

GLuskap

URL

<http://www.cs.uleth.ca/~vpak/gluskap/index.html>

Description

Brief description:
GLuskap is a software tool for displaying graphs in 3-dimensions, interactively editing the resulting drawing and finally creating a high quality ray traced image

	Detailed description:	
Product Version/Status	2.4.1	
Context		
Main Functionalities	<ul style="list-style-type: none"> Automated Layout Graph Manipulation Graph Viewing 	Comments:
Domain	<ul style="list-style-type: none"> Any 	Comments:
Network Representation		
Links	<ul style="list-style-type: none"> Coloured 	Comments:
Nodes	<ul style="list-style-type: none"> Coloured 	
Layout Algorithms	<ul style="list-style-type: none"> Buttefly Circular Random Spring 	Comments:
Dimensionality	<ul style="list-style-type: none"> 3D 	Comments:
User Interaction		
User Interaction	<ul style="list-style-type: none"> Add/Delete Drag & Drop GUI Pan Reposition Resize Rotate Undo/Redo Zoom 	Comments:
Deployment		
	<p>Type:</p> <ul style="list-style-type: none"> Open Source - GPL Standalone Tool 	<p>OS:</p> <ul style="list-style-type: none"> Linux Mac OS X UNIX Windows Windows 2000 Windows XP
OS Comments/Dependencies	<p>GLuskap should run on all of the listed platforms, but has only been tested on Windows 2000/XP, as well as Debian and Mandrake Linux.</p> <p>Requirements: POV-Ray Rendering Requirements -POV-Ray 3.x or greater required to render graphs exported as .pov files</p>	

	<p>(http://www.povray.org)</p> <p>Stereoscopic Viewing -Stereoscopic viewing requires a video device supporting OpenGL quad-buffered stereo.</p> <p>Compilation Requirements -Python 2.3 -wxPython 2.5 with OpenGL support -PyOpenGL 2.0.1.07 -Numarray 1.0</p>	
Extensibility	<ul style="list-style-type: none"> Python 	Comments:
Interoperability	<p>Import/Export GraphML and GML Save display as PNG, JPG, TIFF, or BMP Save display as POV-Ray scene file</p>	
	<p>Hardware:</p> <ul style="list-style-type: none"> 3D Graphics accelerator 	<p>Users:</p> <p>Availability:</p> <ul style="list-style-type: none"> Research Prototype
Cost	Free	Comments:



Images

Src	Tgt	Attr
12	21	1
13	25	0
13	22	0
13	18	0
13	12	0
13	24	0
16	21	0
16	22	1
17	10	0
17	4	0
17	9	0

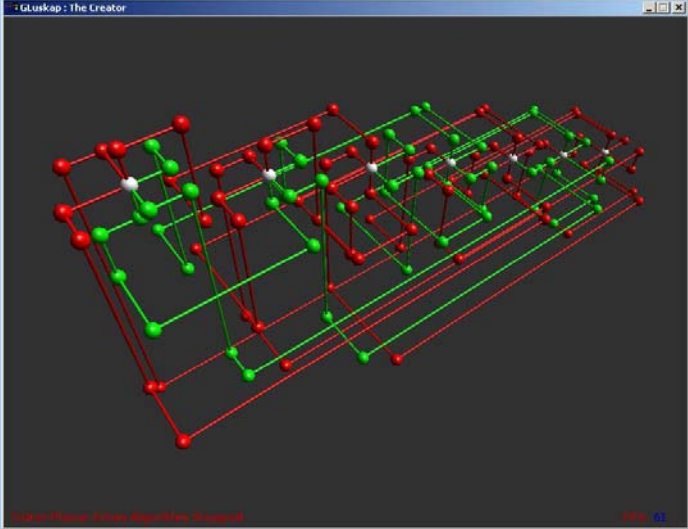
	
Last Modified	2006-12-10 16:39:16

Name	GMorph	
URL	http://gmorph.cs.arizona.edu/gd.html	
Description	<p>Brief description: Intersection-Free Morphing of Planar Graphs</p> <p>Detailed description: Morphing refers to the process of transforming one shape (the source) into another (the target). Morphing is widely used in computer graphics, animation, and modeling. In planar graph morphing we would like to transform a given source graph to another pre-specified target graph. A smooth transformation of one graph into another can be useful for numerous problems from graph drawing. In particular, when dealing with dynamic graphs and graphs that change through time, it is crucial to preserve the mental map of the user. Thus, it is important to minimize the changes to the drawing and to create a smooth transition between consecutive drawings. Another important goal is to avoid creating any intersections throughout the morph. We designed and implemented an algorithm that can morph between drawings with straight-line segments, bends and it relies on a combination of techniques to achieve smooth transformations: rigid morphing, compatible triangulations, as well as morphing based on interpolation of the convex representations of the graphs.</p>	
Context		
Main Functionalities	<ul style="list-style-type: none"> • Graph Manipulation • Graph Viewing 	Comments:
Domain	<ul style="list-style-type: none"> • Any 	Comments:
Network Representation		
Links	<ul style="list-style-type: none"> • Coloured 	Comments:
Nodes	<ul style="list-style-type: none"> • Coloured 	

Layout Algorithms	<ul style="list-style-type: none"> • Planar 	Comments:
Dimensionality	<ul style="list-style-type: none"> • 2D • Temporal 	Comments:
Visual Enhancements		
Visual Enhancements	<ul style="list-style-type: none"> • Animation/Video • Morph 	Comments:
Deployment		
	<u>Type:</u> <ul style="list-style-type: none"> • Standalone Tool 	<u>OS:</u> <ul style="list-style-type: none"> • Multi-Platform (JAVA)
	<u>Hardware:</u>	<u>Users:</u>
		<u>Availability:</u> <ul style="list-style-type: none"> • Research Prototype
Images		
Last Modified	2006-12-14 21:08:23	

Name	GoDiagram	
URL	http://www.nwoods.com/GO/	
Description	<p>Brief description: The GO class libraries are graphical components that allow developers to quickly build graphical applications</p> <p>Detailed description:</p>	
Product Version/Status	JGo 5.1 as of 06/10/21 GoDiagram for .Net 2.5 as of 06/10/21	
Context		
Main Functionalities	<ul style="list-style-type: none"> Automated Layout Graph Manipulation Graph Viewing 	Comments:
Domain	<ul style="list-style-type: none"> Any 	Comments:
Network Representation		
Links	<ul style="list-style-type: none"> Labelled User Defined 	Comments:
Nodes	<ul style="list-style-type: none"> Labelled User Defined 	
Layout Algorithms	<ul style="list-style-type: none"> Force-Directed Tree 	Comments: The AutoLayout package is only available as part of the Professional package
User Interaction		
User Interaction	<ul style="list-style-type: none"> Add/Delete Cut & Paste Drag & Drop Draw GUI Layers Pan Undo/Redo Zoom 	Comments:
Deployment		
	<p>Type:</p> <ul style="list-style-type: none"> Components for tool building 	<p>OS:</p> <ul style="list-style-type: none"> Multi-Platform (JAVA) Windows
Extensibility	<ul style="list-style-type: none"> .NET JAVA MFC 	Comments:

	<p><u>Hardware:</u></p>	<p><u>Users:</u></p>	<p><u>Availability:</u></p> <ul style="list-style-type: none"> Commercially Available
<p><u>Cost</u></p>	<p>Complicated - See Comments</p>	<p>Comments:</p> <p>.NET GoDiagram Express: \$199-\$499 GoDiagram Win: \$895-\$2495 GoDiagram Web: \$895-\$2495 GoDiagram Pocket: \$2495</p> <p>JAVA JGo for Swing: \$895-\$2495 JGo for SWT: \$895-\$2495</p> <p>Go++ MFC: \$895</p> <p>See: http://www.nwoods.com/GO/ordering.htm</p>	



Images

Editor image:

Last Modified	2006-12-18 19:05:28
----------------------	---------------------

Name	GoVisual
-------------	-----------------

URL	http://www.oreas.com/products_en.php	
Description	<p>Brief description: Software and API for automated graph layout and graph editing.</p> <p>Detailed description: The GoVisual Layout Libraries offer provide algorithms for the automatic layout of diagrams for use within custom applications.</p> <p>The GoVisual Diagram editor (GDE) provides functionality for editing and automatic layout of diagrams.</p>	
Context		
Main Functionalities	<ul style="list-style-type: none"> Automated Layout Graph Manipulation Graph Viewing 	Comments:
Network Representation		
Type	<ul style="list-style-type: none"> Directed Undirected 	
Layout Algorithms	<ul style="list-style-type: none"> Circular Clustered Hierarchical Orthogonal Star/Symmetric Tree 	Comments:
Dimensionality	<ul style="list-style-type: none"> 2D 	Comments:
User Interaction		
User Interaction	<ul style="list-style-type: none"> Add/Delete GUI Pan Resize Undo/Redo Zoom 	<p>Comments: Provides complete set of tools for editing graphs/layouts:</p> <ul style="list-style-type: none"> - create/delete nodes/edges - inserting/deleting bend points - resize nodes/clusters - position nodes and clusters - manage clusters - undo/redo
Deployment		
	<p>Type:</p> <ul style="list-style-type: none"> Components for tool building Standalone Tool 	<p>OS:</p> <ul style="list-style-type: none"> Linux Windows
OS Comments/Dependencies	<p>Supported platforms: Microsoft Visual C++ 5.0, 6.0, 7.0, 7.1, and 8.0 Borland C++ Builder 5 and 6 every other language capable of using COM-Interfaces, e.g., VisualBasic</p>	

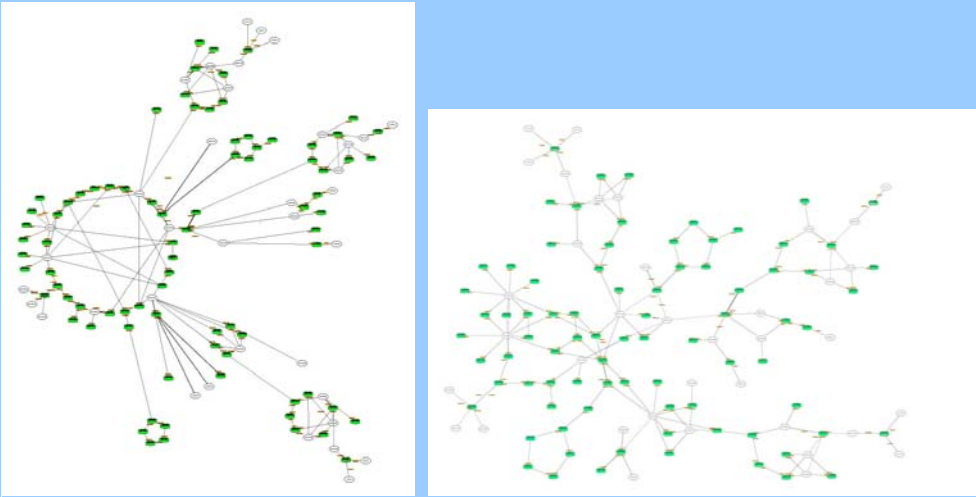
	<p>MS .NET Framework 1.1 and 2.0</p> <p>Java SDK 1.4 and 1.5 via JNI-interface on x86 systems running Microsoft Windows or Linux</p> <p>g++ version 3.3, 3.4, and 4.1 on x86 platforms</p>	
<u>Extensibility</u>	<ul style="list-style-type: none"> • .NET • C++ • COM • JAVA 	Comments:
<u>Interoperability</u>	<p>Import/export GML files</p> <p>Import CSV files</p> <p>Export JPG, PNG, BMP, and SVG files</p>	
	<u>Hardware:</u>	<u>Users:</u> <p style="text-align: right;"><u>Availability:</u></p> <ul style="list-style-type: none"> • Commercially Available
<u>Cost</u>	Complicated - See Comments	Comments: The GoVisual Diagram Editor is freely available. API cost: See API_price_list_dollar.pdf
Images		

Last Modified	2006-12-18 23:15:27	

Name	Graph Magics	
URL	http://www.graph-magics.com/	
Description	<p>Brief description: A tool for graph theory, having a generator and offering various algorithms: shortest paths, network flows, maximal clique, optimal coloring etc.</p> <p>Detailed description:</p>	
Product Version/Status	2.1 (13 june 2005)	
Context		
Main Functionalities	<ul style="list-style-type: none"> Automated Layout Graph Manipulation Graph Viewing Network Analysis 	Comments:
Domain	<ul style="list-style-type: none"> Any 	Comments:
Network Representation		
Layout Algorithms	<ul style="list-style-type: none"> Circular Grid Tree 	Comments:
Dimensionality	<ul style="list-style-type: none"> 2D 	Comments:
Analysis		

<u>Network Analysis</u>	<ul style="list-style-type: none"> • Cohesion:Clique • Connection:Flow • Connection:Minimal Spanning Tree • Connection:Node Connectivity • Connection:Shortest Path • Eulerian Path • Hamiltonian Path 	Comments:
User Interaction		
<u>User Interaction</u>	<ul style="list-style-type: none"> • Cut & Paste • GUI • Undo/Redo • Zoom 	Comments:
Deployment		
	<u>Type:</u> <ul style="list-style-type: none"> • Standalone Tool 	<u>OS:</u> <ul style="list-style-type: none"> • Windows
<u>Interoperability</u>	Importation and exportation of graphs from raw data files of different structures (adjacency matrix, neighbours list, edges list).	
<u>Scalability</u>	Max Nodes: 101-1000 Max Links: 101-1000	Comments:
<u>Cost</u>	\$1 - \$100	Comments:

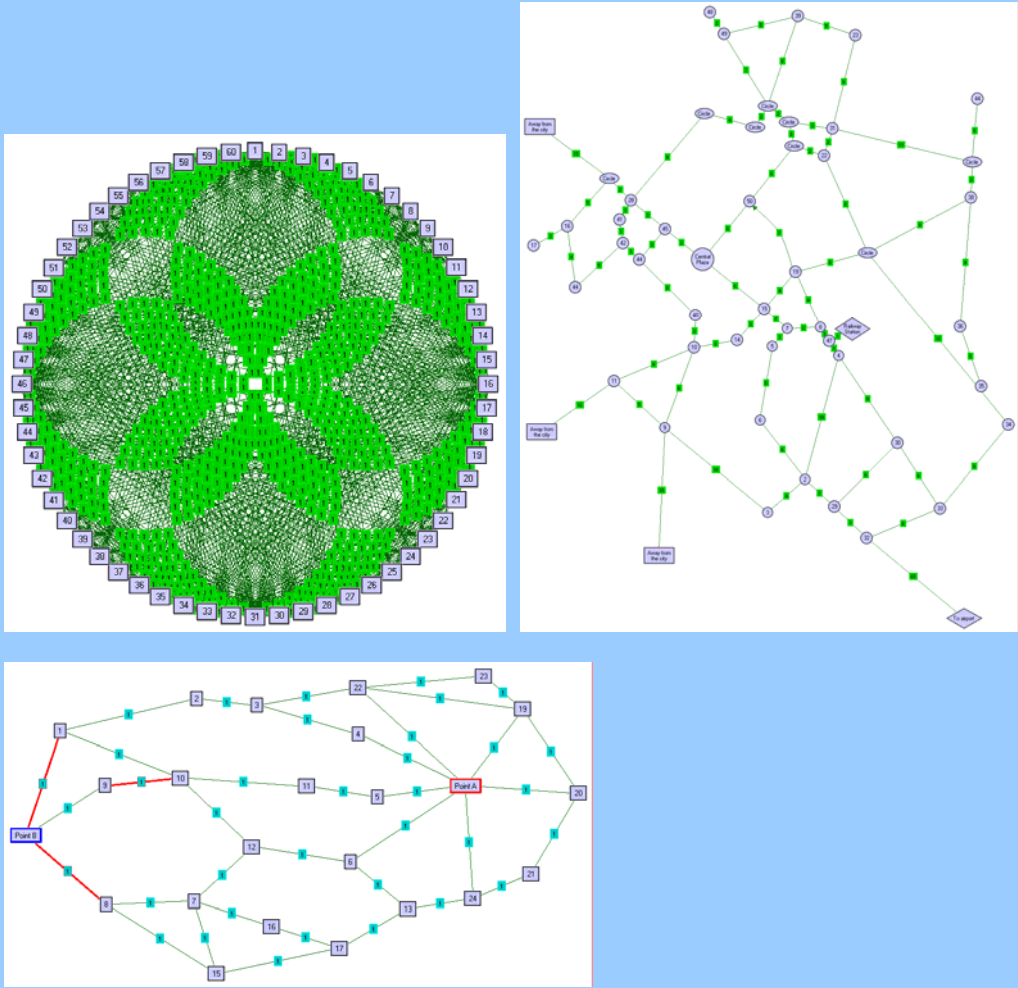
<p>Images</p>	
<p>Last Modified</p>	<p>2006-12-18 19:06:01</p>

<p>Name</p>	<p>Graph Visualization Library (VTK)</p>
<p>URL</p>	<p>http://www.comp.leeds.ac.uk/djd/graphs/</p>
<p>Description</p>	<p>Brief description: A library that adds graph visualization support to VTK</p> <p>Detailed description: It can be argued that VTK already supports representation of graphs, for example polydata or an unstructured grid can be used to encode a graph, using points to denote nodes and lines to encode edges. Although workable, this suffers from two problems:</p> <ul style="list-style-type: none"> • i. In writing graph algorithms, it is useful to have ready access to properties such as the number of children of a node, and to have simple means of traversing parts of the graph structure, for example all edges incoming to a particular node. • ii. With pipelines that involve making subgraphs, or matching different representations of the underlying graph, it is important to be able to determine when two nodes or edges are the same. Point and cell ids are

	<p>allocated to make optimal use of storage, and if nodes and edges are to be matched or related, there must be a globally unique way of labelling them.</p> <p>The graph library addresses these issues by defining a new type of dataset, vtkGraph, that (i) provides a high-level interface to graph structure, and (ii) provides a means of uniquely assigning ids to nodes and edges while managing efficient storage of the graph and associated data. The library is currently supported by a number of filters that provide various layout operations, mapping graph datasets to geometric form (polydata), and other functions that have use in graph visualization tasks.</p>	
Product Version/Status	1.2 Requires VTK	
Context		
Domain	<ul style="list-style-type: none"> Any 	Comments:
Network Representation		
Layout Algorithms	<ul style="list-style-type: none"> Cone Tree GEM Hierarchical (Reingold-Tilford) Tree 	Comments:
Dimensionality	<ul style="list-style-type: none"> 2D 3D 	Comments:
Deployment		
	<u>Type:</u> <ul style="list-style-type: none"> Components for tool building Open Source 	<u>OS:</u>
Extensibility	<ul style="list-style-type: none"> Tcl/Tk 	Comments:
Interoperability	Read and write GML files	
Scalability	Max Nodes: 10,001-100,000 Max Links: 10,001-100,000	Comments:
	<u>Hardware:</u>	<u>Users:</u> <u>Availability:</u> <ul style="list-style-type: none"> Freeware Unsupported
Cost	Free	Comments:

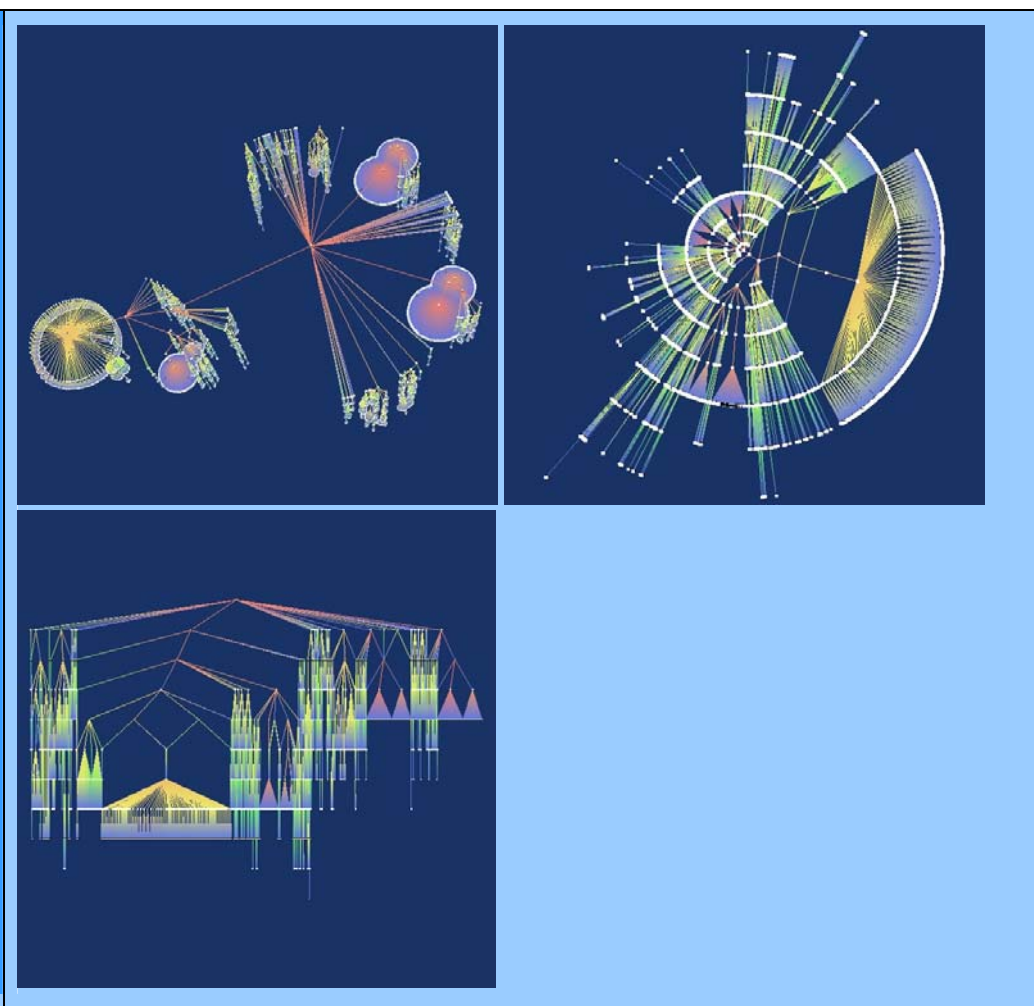
<p>Images</p>	
<p>References</p>	<p>README http://www.comp.leeds.ac.uk/djd/graphs/README.html#s8</p>
<p>Last Modified</p>	<p>2006-12-14 20:52:10</p>

<p>Name</p>	<p>GraphAEL</p>
<p>URL</p>	<p>http://graphael.cs.arizona.edu/graphael/</p>
<p>Description</p>	<p>Brief description: A System for Generalized Force-Directed Layouts</p> <p>Detailed description: The graphael system implements several classic force-directed layout methods, as well as several novel layout methods for non-Euclidean geometries, including hyperbolic and spherical. The system can handle large graphs, using multi-scale variations of the force-directed methods. Finally, the system can layout and visualize graphs that evolve though time, using static views, animation, and morphing.</p>
<p>Product Version/Status</p>	<p>1.1.4</p>
<p>Context</p>	

<u>Main Functionalities</u>	<ul style="list-style-type: none"> Automated Layout Graph Viewing 	Comments:
<u>Domain</u>	<ul style="list-style-type: none"> Any 	Comments:
Network Representation		
<u>Links</u>	<ul style="list-style-type: none"> Coloured Weighted 	Comments:
<u>Nodes</u>	<ul style="list-style-type: none"> Coloured Labelled Weighted 	
<u>Layout Algorithms</u>	<ul style="list-style-type: none"> Force-Directed Hyperbolic Tree Spherical Spring Spring FR Spring KK 	Comments:
<u>Dimensionality</u>	<ul style="list-style-type: none"> 2D 3D Temporal 	<p>Comments:</p> <p>The algorithms used to display the evolution of time-based graphs are modified Spring FR and Spring KK algorithms that allow vertex-weighted and edge-weighted graphs. Graphs that change over time are converted to weighted graphs by treating each instance of the graphs as a timeslice and connecting neighboring timeslices. The edges connecting different timeslices are called inter-timeslice edges. By modifying the weights of these edges, a balance can be achieved between the readability of individual graphs and the overall mental map preservation between consecutive graphs.</p> <p>Also, GraphAEL can generate and display difference graphs. The difference graph between two adjacent timeslices captures the difference between the two underlying graphs.</p>
Visual Enhancements		
<u>Visual Enhancements</u>	<ul style="list-style-type: none"> Animation/Video Morph 	Comments:
User Interaction		
<u>User Interaction</u>	<ul style="list-style-type: none"> GUI 	Comments:
Deployment		
	<u>Type:</u> <ul style="list-style-type: none"> Standalone Tool 	<u>OS:</u> <ul style="list-style-type: none"> Multi-Platform (JAVA)

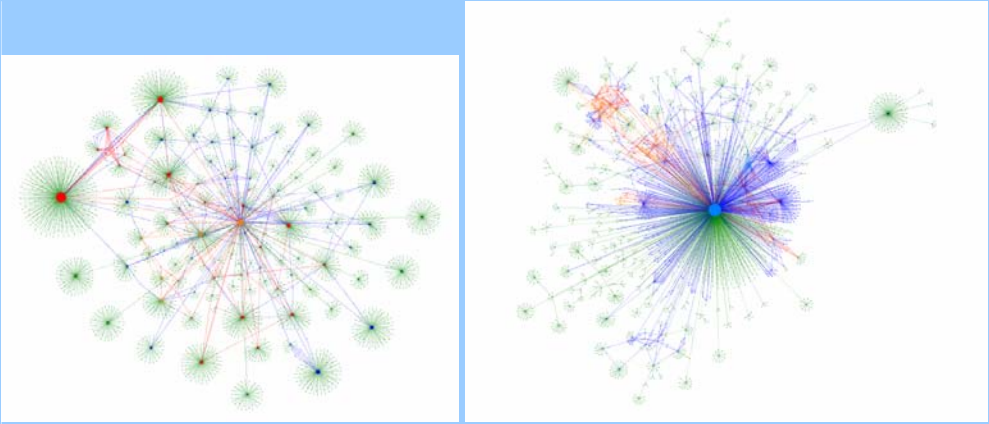
<u>Scalability</u>	Max Nodes: Unlimited Max Links: Unlimited	Comments:
	<u>Hardware:</u>	<u>Users:</u> • Single
		<u>Availability:</u> • Research Prototype
Images		
Last Modified	2006-12-14 21:09:06	

Name	Graphlet and GTL	
URL	http://www.brainsys.de/	
Description	<p>Brief description: A graph editor and graph layout toolkit.</p> <p>Detailed description: The core of Graphlet is implement in C++ using STL, GTL, and Graphscript (a Tcl/Tk based language). All of the Graphlet functions can be accessed via Graphscript. The Graphlet graph editor is implemented using Graphscript.</p>	
<u>Product Version/Status</u>	5.0.1.5	
Context		
<u>Main Functionalities</u>	<ul style="list-style-type: none"> • Automated Layout • Graph Manipulation • Graph Viewing 	Comments:
Deployment		

	Type: <ul style="list-style-type: none"> • Components for tool building • Standalone Tool OS:	
Extensibility	<ul style="list-style-type: none"> • C++ • Tcl/Tk 	Comments: GTL is a platform independent and extendible C++ library. GTL contains the classes needed to work with graphs, nodes and edges and some fundamental algorithms as building blocks for more complex graph algorithms. Further algorithms are under development.
References	http://www.infosun.fmi.uni-passau.de/Graphlet/	
Last Modified	2006-12-10 16:39:16	

Name	graphopt	
URL	http://www.schmuhl.org/graphopt/	
Description	Brief description: This program optimizes graph layouts. That's pretty much it. Detailed description:	
Product Version/Status	0.4.1 (2003-05-06) There does not appear to be any active development.	
Context		
Main Functionalities	<ul style="list-style-type: none"> • Automated Layout • Graph Viewing 	Comments:
Domain	<ul style="list-style-type: none"> • Any 	Comments:
Network Representation		
Type	<ul style="list-style-type: none"> • Directed • Undirected 	
Layout Algorithms	<ul style="list-style-type: none"> • Spring 	Comments: The user has access to many of the layout algorithm parameters.
Dimensionality	<ul style="list-style-type: none"> • 2D 	Comments:
Deployment		
	Type:	OS:

	<ul style="list-style-type: none"> • Open Source • Standalone Tool 	
<u>Interoperability</u>	<p>Graphs can be imported using a subset of the dot format from AT&T Research</p> <p>There is also a module to export graphs in a Visio-importable format.</p>	
	<u>Hardware:</u>	<u>Users:</u> <ul style="list-style-type: none"> • Unsupported
<u>Cost</u>	Free	<u>Comments:</u>

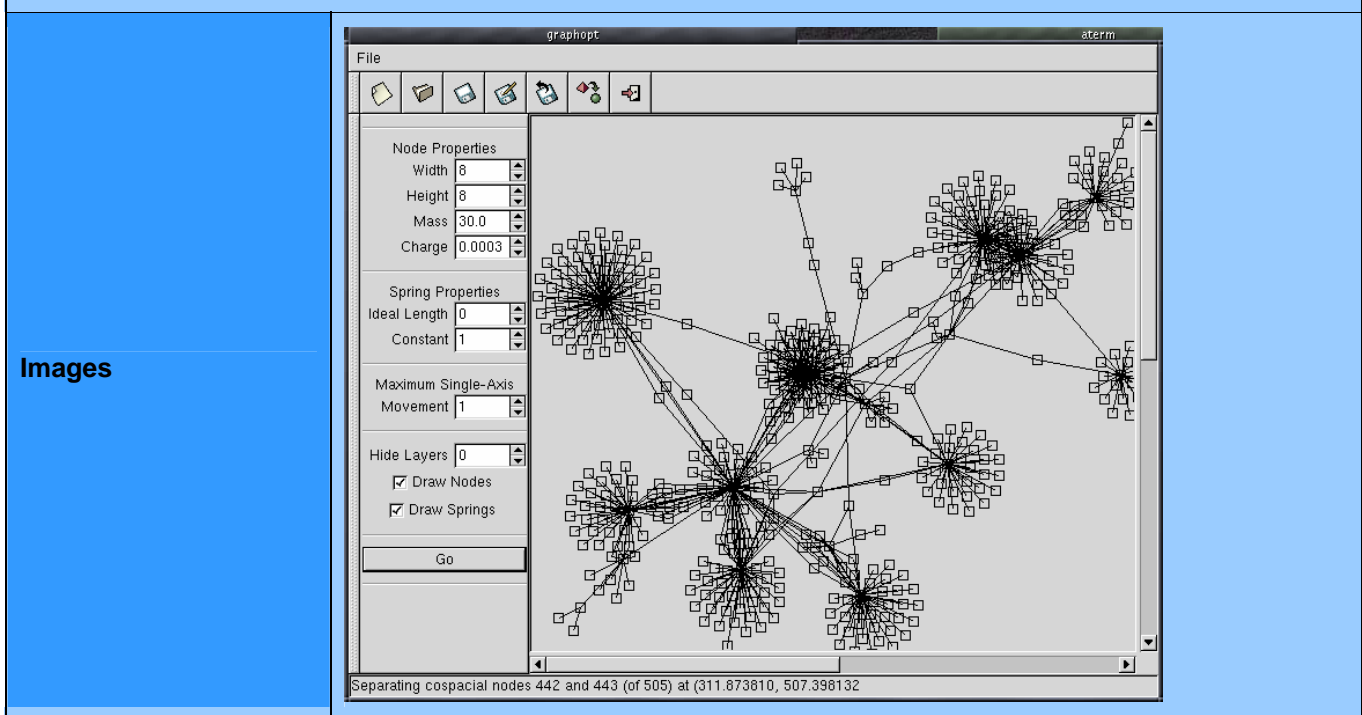

Last Modified	2006-12-14 20:51:43
----------------------	---------------------

Name	GraphPlot
URL	http://coral.wcupa.edu/sociometry/chp555.htm
Description	<p>Brief description: GraphPlot is a spreadsheet and a drawing tool for sociometric data</p> <p>Detailed description:</p>



<u>Main Functionalities</u>	<ul style="list-style-type: none"> • Graph Manipulation • Graph Viewing 	<u>Comments:</u>
-----------------------------	---	------------------

Domain	<ul style="list-style-type: none"> Social Networks 	Comments:
Network Representation		
Dimensionality	<ul style="list-style-type: none"> 2D 	Comments:
Deployment		
	Type: <ul style="list-style-type: none"> Standalone Tool 	OS: <ul style="list-style-type: none"> Windows
Scalability	Max Nodes: Unlimited Max Links: Unlimited	Comments:
Images		
Last Modified	2006-12-10 16:39:16	

Name	Graphviz
URL	http://www.graphviz.org/
Description	<p>Brief description: A set of graph drawing tools for Unix or Windows. Designed for visualizing structural information by constructing geometric representations of abstract graphs and networks.</p> <p>Detailed description:</p>

	<p>The Graphviz layout programs take descriptions of graphs in a simple text language, and make diagrams in several useful formats such as images and SVG for web pages, Postscript for inclusion in PDF or other documents; or display in an interactive graph browser.</p> <p>The Graphviz package consists of a variety of software for drawing attributed graphs. It implements a handful of common graph layout algorithms. These are:</p> <p>dot - A Sugiyama-style hierarchical layout.</p> <p>neato - An implementation of the Kamada-Kawai algorithm for “symmetric” layouts. This is a variation of multidimensional scaling.</p> <p>fdp - An implementation of the Fruchterman-Reingold algorithm for “symmetric” layouts. This layout is similar to neato, but there are performance and feature differences.</p> <p>twopi - A radial layout as described by Wills.</p> <p>circo - A circular layout combining aspects of the work of Six and Tollis and Kaufmann and Wiese.</p>	
Product Version/Status	2.12	
Context		
Domain	<ul style="list-style-type: none"> Any 	Comments:
Network Representation		
Type	<ul style="list-style-type: none"> Directed Undirected 	
Layout Algorithms	<ul style="list-style-type: none"> Circular Hierarchical (Sugiyama) Random Spring FR Spring KK 	Comments:
Dimensionality	<ul style="list-style-type: none"> 2D 	Comments:
Deployment		
	Type: <ul style="list-style-type: none"> Components for tool building Open Source Standalone Tool 	OS: <ul style="list-style-type: none"> Linux UNIX Windows
Extensibility	<ul style="list-style-type: none"> C++ 	Comments:
Interoperability	Output file formats http://www.graphviz.org/doc/info/output.html	
	Hardware:	Users: Availability: <ul style="list-style-type: none"> Freeware In Development
Cost	Free	Comments:

Distributed under Common Public License
Version 1.0
<http://www.graphviz.org/Download.php>

Images

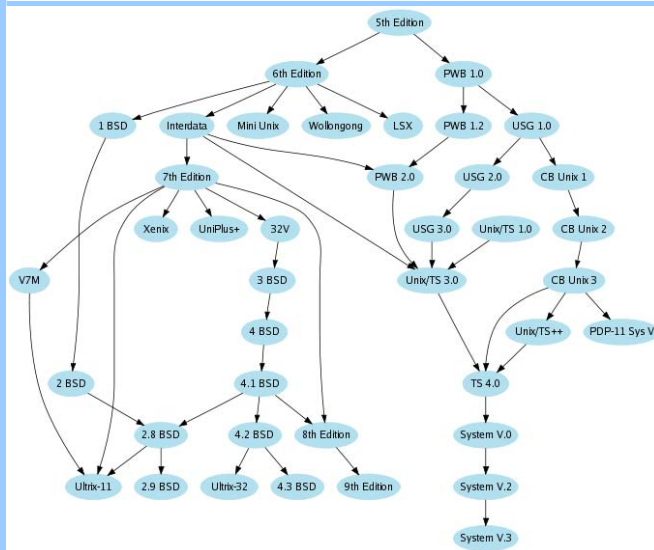
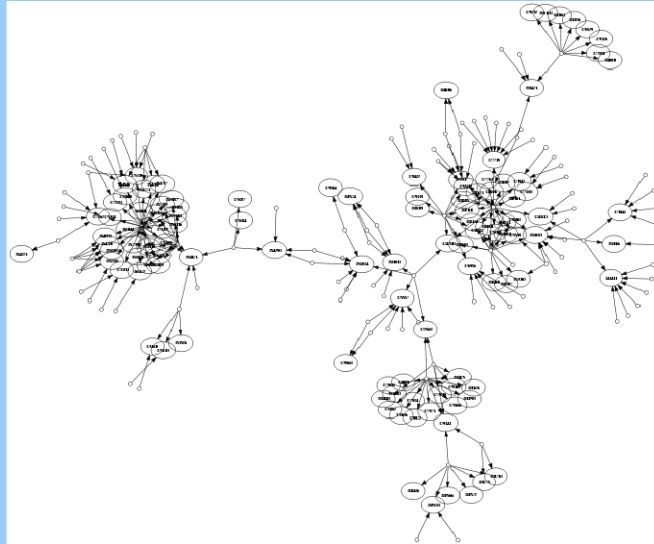

Last Modified

2006-12-14 20:57:01

Name

Gravisto

URL

<http://gravisto.fmi.uni-passau.de/>

Description

Brief description:

Gravisto is an editor for graphs and a toolkit for implementing graph visualization algorithms.

Detailed description:

Product Version/Status	There have been no releases yet	
Context		
Main Functionalities	<ul style="list-style-type: none"> Automated Layout Graph Manipulation Graph Viewing 	Comments:
Domain	<ul style="list-style-type: none"> Any 	Comments:
Network Representation		
Links	<ul style="list-style-type: none"> Coloured Labelled 	Comments:
Nodes	<ul style="list-style-type: none"> Labelled Symbol 	
Dimensionality	<ul style="list-style-type: none"> 2D 	Comments:
Deployment		
	Type: <ul style="list-style-type: none"> Components for tool building Open Source - GPL 	OS: <ul style="list-style-type: none"> Multi-Platform (JAVA)
Extensibility	<ul style="list-style-type: none"> JAVA 	Comments: An extensive plugin architecture is provided. http://gravisto.fmi.uni-passau.de/doc/guide/plugins/index.html
	Hardware:	Users: Availability: <ul style="list-style-type: none"> In Development Research Prototype

Images

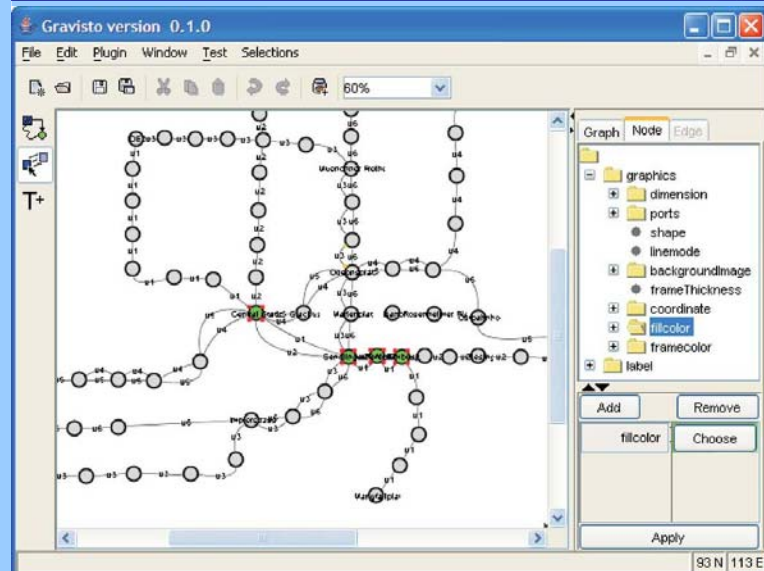
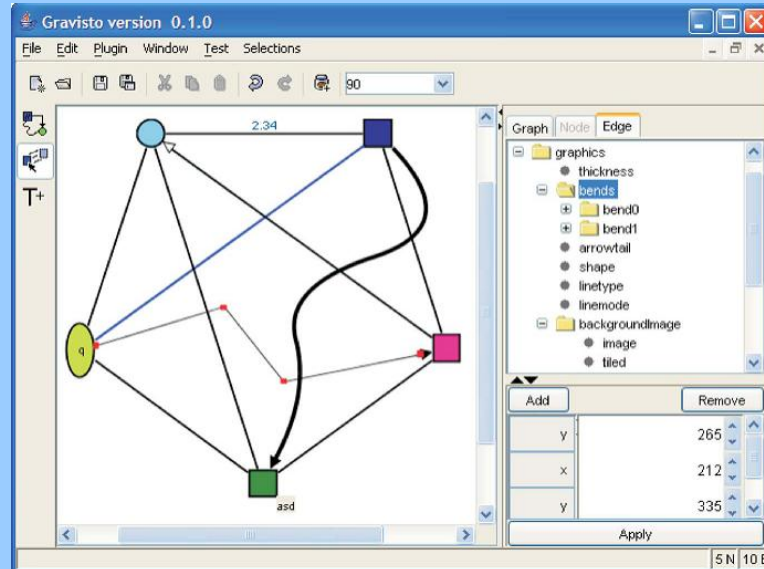

References

API Docs
http://gravisto.fmi.uni-passau.de/doc/api/Graffiti_Core/index.html

Last Modified

2006-12-10 16:39:16

Name

GRIP/GUIDE

URL

<http://www.cs.arizona.edu/~kobourov/GRIP/>

Description

Brief description:

Graph dRrawing with Intelligent Placement

Detailed description:

GRIP is designed for drawing large graphs and uses a novel multi-dimensional force-directed method together with fast energy function minimization. The algorithm underlying the system employs a simple recursive coarsening scheme. Rather than

	<p>being placed at random, vertices are placed intelligently, several at a time, at locations close to their final positions. The running time and space complexity of the system are near linear. The implementation is in C using OpenGL for 3D viewing. GRIP allows for drawing graphs with tens of thousands of vertices in under one minute on a mid-range PC. To the best of the authors' knowledge, GRIP surpasses the fastest previous algorithms. However, speed is not achieved at the expense of quality as the resulting drawings are quite aesthetically pleasing.</p>	
Context		
<u>Main Functionalities</u>	<ul style="list-style-type: none"> Automated Layout Graph Viewing 	Comments:
<u>Domain</u>	<ul style="list-style-type: none"> Any 	Comments:
Network Representation		
<u>Type</u>	<ul style="list-style-type: none"> Undirected 	
<u>Links</u>	<ul style="list-style-type: none"> Weighted 	Comments:
<u>Nodes</u>	<ul style="list-style-type: none"> Weighted 	
<u>Layout Algorithms</u>	<ul style="list-style-type: none"> Force-Directed GRIP Spring Spring FR 	Comments: The GRIP (Graph dRrawing with Intelligent Placement) system draws graphs. The inputs are simple undirected graphs (adjacency list or adjacency matrix) and the output is a drawing in 2D or 3D. The algorithm relies on a spring-embedder method, where the graph is treated as a spring-system. The final drawing corresponds to a low energy configuration.
<u>Dimensionality</u>	<ul style="list-style-type: none"> 2D 3D 	Comments:
User Interaction		
<u>User Interaction</u>	<ul style="list-style-type: none"> Drag & Drop GUI Pan Reposition Rotate Zoom 	Comments:
Deployment		
	<u>Type:</u> <ul style="list-style-type: none"> Standalone Tool 	<u>OS:</u> <ul style="list-style-type: none"> Linux
<u>OS Comments/ Dependencies</u>	tested on Linux SuSE 8.0/7.3-Systems but should work on other systems Requires: xerces version 1.7.0	

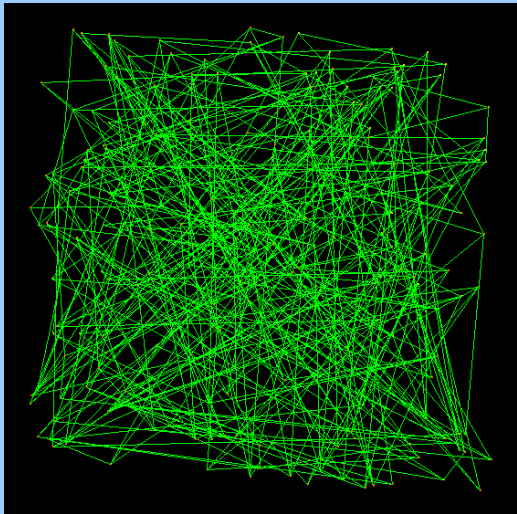
	a GLU-library (e.g. MesaGlu)	
<u>Extensibility</u>	<ul style="list-style-type: none"> C 	Comments:
<u>Interoperability</u>	Import GML and GraphML	
<u>Scalability</u>	Max Nodes: Unlimited Max Links: Unlimited	Comments:
	<u>Hardware:</u>	<u>Users:</u> <ul style="list-style-type: none"> Single <u>Availability:</u> <ul style="list-style-type: none"> Research Prototype
Images		
<u>References</u>	User's guide http://www.cs.arizona.edu/~kobourov/GRIP/users_guide.html	
Last Modified	2006-12-10 16:39:16	

Name	GTrace
URL	http://www.caida.org/tools/visualization/gtrace/
Description	<p>Brief description: GTrace is a graphical front-end to traceroute (which routes packets) that depicts geographically the IP path information between source and destination hosts.</p> <p>Detailed description:</p>
<u>Product Version/Status</u>	Version 1.0.0 (beta) 1999-05-11 Requires JDK 1.1.7 or higher

Context

Main Functionalities	<ul style="list-style-type: none"> Automated Layout Graph Viewing 	Comments:
Domain	<ul style="list-style-type: none"> Computer Networks 	Comments:

Network Representation

Links	<ul style="list-style-type: none"> Labelled 	Comments:
Nodes	<ul style="list-style-type: none"> Labelled 	
Dimensionality	<ul style="list-style-type: none"> 2D Geospatial 	Comments:

Deployment

Type:	<ul style="list-style-type: none"> Open Source Standalone Tool 	OS:	<ul style="list-style-type: none"> Linux Solaris
--------------	--	------------	--

Cost	Free	Comments:
-------------	------	------------------

Screenshots

Images

The screenshot shows the gTrace v1.0.0 application window. At the top, there's a menu bar with 'Trace', 'Maps', 'Tools', 'Options', and 'Help'. Below the menu bar, there's a search bar containing 'swidir.switch.ch' and a coordinate field showing 'Lat/Lon: 39.90N, 2.0E'. The main area displays a world map with a highlighted path in blue and yellow. Below the map is a table with the following columns: Plot, Hop, IP Address, Interface Name, Location, and RTT (ms).

Plot	Hop	IP Address	Interface Name	Location	RTT (ms)
<input checked="" type="checkbox"/>	1	(192.172.228.65)	plnot-fe2-0-0	32.72 N, 117.16 W	0.9
<input checked="" type="checkbox"/>	2	(198.17.46.10)	medusa.sdsc.edu	32.70 N, 117.15 W	0.612
<input checked="" type="checkbox"/>	3	(192.12.207.5)	sdsc-gw-san-bb1.cerf.net	32.72 N, 117.16 W	1.768
<input type="checkbox"/>	4	(10.17.7.20)	10.17.7.20	Private Internet Use	2.169
<input checked="" type="checkbox"/>	5	(134.24.28.130)	pos0-0-155M.san-bb6.cerf.net	32.72 N, 117.16 W	2.992
<input checked="" type="checkbox"/>	6	(134.24.29.142)	atm6-0-1-622M.lax-bb4.cerf.net	33.97 N, 118.25 W	7.385
<input checked="" type="checkbox"/>	7	(134.24.32.122)	pos0-0-0-155M.lax-bb6.cerf.net	33.97 N, 118.25 W	7.701
<input checked="" type="checkbox"/>	8	(134.24.32.54)	atm0-0-0-bp1.lax-alt.net	33.97 N, 118.25 W	7.837
<input checked="" type="checkbox"/>	9	(146.188.248.30)	104.ATM2-0.XR2.LAX4.ALTER.NET	33.97 N, 118.25 W	8.336
<input checked="" type="checkbox"/>	10	(146.188.249.10)	252.ATM2-0.TR2.LAX2.ALTER.NET	33.97 N, 118.25 W	7.781
<input checked="" type="checkbox"/>	11	(146.188.137.134)	111.ATM7-0.TR2.NYC1.ALTER.NET	40.75 N, 74.0 W	78.65
<input checked="" type="checkbox"/>	12	(146.188.179.33)	198.ATM6-0.XR2.NYC4.ALTER.NET	40.75 N, 74.0 W	79.927
<input checked="" type="checkbox"/>	13	(152.63.21.197)	188.ATM6-0.GWS.NYC4.ALTER.NET	40.75 N, 74.0 W	79.334
<input type="checkbox"/>	14	(157.130.13.62)	switch-gw.customer.ALTER.NET	38.86 N, 77.26 W	80.672
<input checked="" type="checkbox"/>	15	(130.59.33.1)	swIEG1-A5-0-0-1.switch.ch	47.37 N, 8.55 E	184.323
<input checked="" type="checkbox"/>	16	(130.59.20.206)	swIEZ1-F1-0-0.switch.ch	47.37 N, 8.55 E	185.274
<input checked="" type="checkbox"/>	17	(130.59.33.105)	swIGEX-A0-0-3.switch.ch	46.21 N, 6.8 E	197.317
<input checked="" type="checkbox"/>	18	(130.59.33.82)	swIEL1-A4-0-0-1.switch.ch	46.51 N, 6.63 E	201.896
<input checked="" type="checkbox"/>	19	(130.59.72.10)	mbone-ls.switch.ch	46.51 N, 6.63 E	192.46

Last Modified	2006-12-10 16:39:16
----------------------	---------------------

Name	GUESS: The Graph Exploration System
URL	http://graphexploration.cond.org/

<p>Description</p>	<p>Brief description: GUESS is an exploratory data analysis and visualization tool for graphs and networks.</p> <p>Detailed description: GUESS is a database driven system that allows nodes and edges to include attributes beyond basic display features (GUESS supports continuous, categorical, and binary attributes). The Gython language gives you access to these properties without typing in database queries.</p> <p>The GUESS visualization component is a zoomable interface to large graphs allowing for the visualization of graphs and networks on an infinite plane with infinite (smooth) zoom. Try the applet to get a sense of this. The (recommended) interface is based on Piccolo, but you can also swap the interface with others systems (initial support for Prefuse and TouchGraph).</p> <p>GUESS Features:</p> <ul style="list-style-type: none"> • A completely refactored version of the Zoomgraph graph visualization system. • Robust language for selecting and managing nodes and edges. We have now taken the Jython core (Python in Java) and have extended it for graph/GUESS specific syntax. • Utilizes JUNG, a robust graph library, as a backend to represent nodes and graphs. • A zoomable interface to large graphs. Zoomable means you can smoothly zoom in and out and easily move between nodes. Additionally, the new version is slowly getting support for rendering the graphs in Prefuse or TouchGraph (works in a limited way right now). • A database driven system. Nodes and edges have features that you can query and use to control what gets displayed (e.g. show all the nodes and interactions for yeast genes that have a metabolic function, show all the email communications between two departments). • Ability to save state and to smoothly morph between states • Writes out many different types (jpg, gif, pdf, eps, svg, swf) • Various layout algorithms • Interface to R • Support for subgraphs 	
<p>Product Version/Status</p>	<p>1.0.2beta (10/26/2006)</p>	
<p>Context</p>		
<p>Domain</p>	<ul style="list-style-type: none"> • Any 	<p>Comments:</p>
<p>Network Representation</p>		
<p>Type</p>	<ul style="list-style-type: none"> • Directed • Undirected 	
<p>Links</p>	<ul style="list-style-type: none"> • User Defined 	<p>Comments:</p>
<p>Nodes</p>	<ul style="list-style-type: none"> • User Defined 	<p>Guess is database driven, so nodes and links can contain any attributes. These attributes can be used to control what gets displayed (e.g. show all the nodes and interactions for yeast genes that have a metabolic function, show all</p>

		the email communications between two departments).
<u>Layout Algorithms</u>	<ul style="list-style-type: none"> • Circular • Clustered • GEM • Group By • MDS • Radial • Random • Spring • Spring FR • Spring KK 	Comments:
<u>Dimensionality</u>	<ul style="list-style-type: none"> • 2D • Temporal 	Comments:
Analysis		
<u>General Analysis</u>	<ul style="list-style-type: none"> • Statistics:Descriptives 	Comments:
<u>Network Analysis</u>	<ul style="list-style-type: none"> • Centrality:Betweenness • Centrality:Degree • Centrality:HITS • Centrality:Link Betweenness • Centrality:PageRank • Centrality:Random-walk Betweenness 	Comments:
Visual Enhancements		
<u>Visual Enhancements</u>	<ul style="list-style-type: none"> • Animation/Video • Morph 	Comments:
User Interaction		
<u>User Interaction</u>	<ul style="list-style-type: none"> • Add/Delete • Drag & Drop • GUI • Reposition • Zoom 	Comments:
Deployment		
	<u>Type:</u> <ul style="list-style-type: none"> • Open Source - GPL • Standalone Tool 	<u>OS:</u> <ul style="list-style-type: none"> • Multi-Platform (JAVA)
<u>OS Comments/Dependencies</u>	Java Runtime (1.4+) The Java Media Framework (If you want to save out animations)	
<u>Extensibility</u>	<ul style="list-style-type: none"> • JAVA • Python 	Comments: The system contains a domain-specific

		<p>embedded language called Gython (an extension of Python, or more specifically Jython) which supports the operators and syntactic sugar necessary for working on graph structures in an intuitive manner. An interactive interpreter binds the text that you type in the interpreter to the objects being visualized for more useful integration.</p>
<u>Interoperability</u>	<p>GraphML - there is limited support for this format (no subgraphs or hyperedges). Also, nodes need to be defined before edges.</p> <p>GUESS is able to export to the following image formats: GIF, JPG, PDF, PS, EPS, SVG, SWF, JAVA, CGM, EMF, and PNG</p>	
<u>Scalability</u>	<p>Max Nodes: Unlimited</p> <p>Max Links: Unlimited</p>	Comments:
	<p><u>Hardware:</u></p>	<p><u>Users:</u></p> <ul style="list-style-type: none"> • Single
		<p><u>Availability:</u></p> <ul style="list-style-type: none"> • Freeware • In Development • In Use
<u>Cost</u>	Free	Comments:



Images

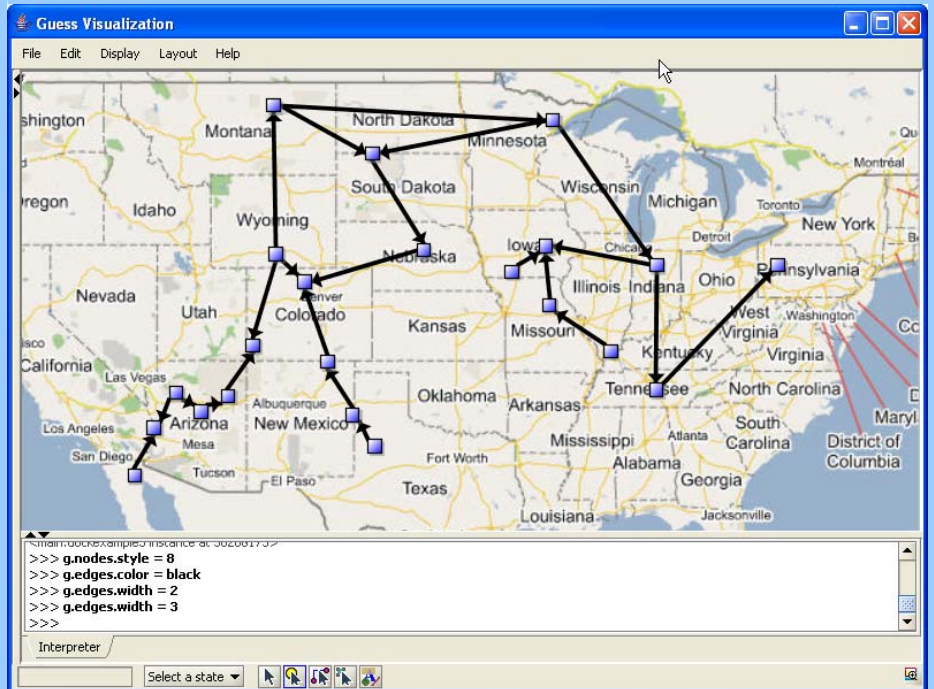
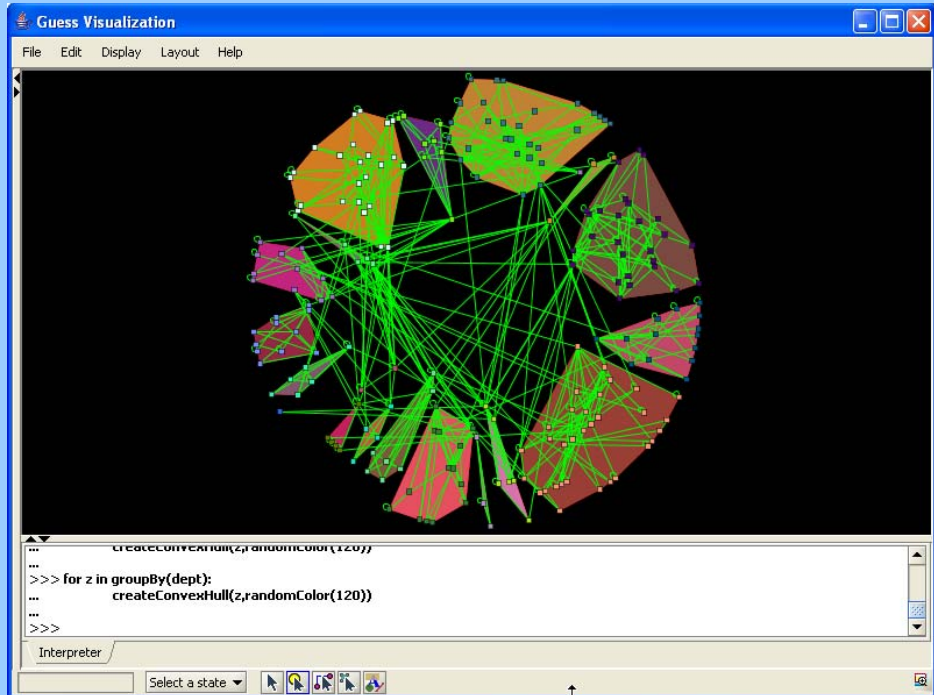

Last Modified

2006-12-18 19:55:24

Name

GVF - The Graph Visualization Framework

URL

<http://gvf.sourceforge.net/>

Description

Brief description:

The Graph Visualization Framework is a set of design patterns and approaches that

	<p>can serve as an example for applications that either manipulate graph structures or visualize them.</p> <p>Detailed description: The libraries implement several basic modules for input, graph management, layout and rendering. The modules can be used independently of each other without modification. For example, the graph management module may be used as the data structure for an application that does not require visualization. An application called "Royère" has been developed as a testbed for the GVF libraries. Royère can be extended and modified as required to suit your needs.</p>	
Product Version/Status	1.36 (2004-03-03)	
Context		
Domain	<ul style="list-style-type: none"> Any 	Comments:
Network Representation		
Layout Algorithms	<ul style="list-style-type: none"> Barycentric Circular Clustered Hierarchical (Reingold-Tilford) Radial Random 	Comments:
Dimensionality	<ul style="list-style-type: none"> 2D 	Comments:
User Interaction		
User Interaction	<ul style="list-style-type: none"> Add/Delete Filter Focus GUI Undo/Redo 	Comments:
Deployment		
	<p>Type:</p> <ul style="list-style-type: none"> Components for tool building Open Source 	<p>OS:</p> <ul style="list-style-type: none"> Linux Multi-Platform (JAVA) Windows
Extensibility	<ul style="list-style-type: none"> JAVA 	Comments:
Interoperability	<p>Reads GML, GraphXML, and CNS (Newick Format)</p> <p>Exports views to SVG, JPG, PNG, and BMP</p>	
	Hardware:	<p>Users:</p> <p>Availability:</p> <ul style="list-style-type: none"> Freeware Unsupported

Cost	Free - For noncommercial use	Comments:
-------------	------------------------------	------------------



Images

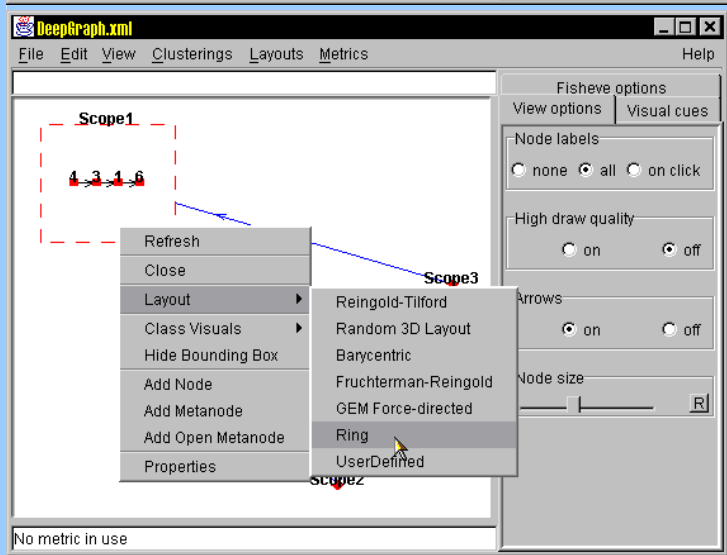
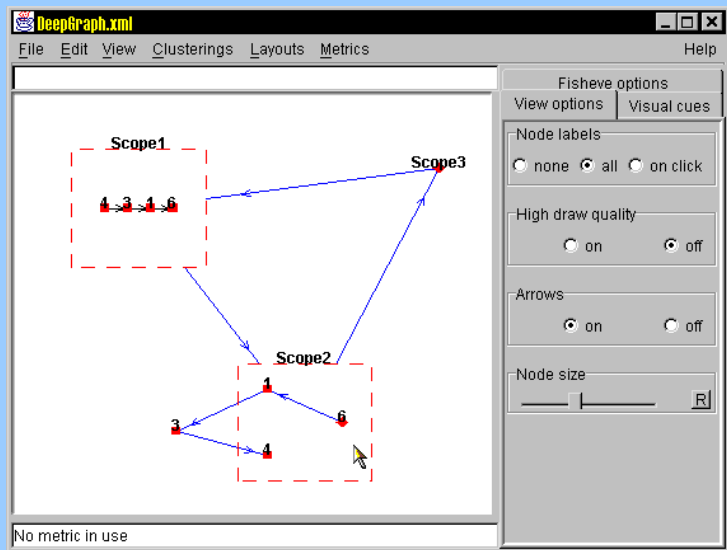

Last Modified	2006-12-18 19:06:58
----------------------	---------------------

Name	H3Viewer
URL	http://graphics.stanford.edu/papers/h3/
Description	<p>Brief description: H3Viewer is a 3D graph visualization tool that allows intuitive exploration of hierarchical graphs.</p> <p>Detailed description: The H3Viewer library can handle graphs two orders of magnitude larger than most other systems by manipulating a backbone spanning tree instead of the full graph.</p>

Context		
Main Functionalities	<ul style="list-style-type: none"> Automated Layout Graph Manipulation Graph Viewing 	Comments:
Domain	<ul style="list-style-type: none"> Any 	Comments:
Network Representation		
Links	<ul style="list-style-type: none"> User Defined 	Comments: Any JAVA data type can be used for link/node attributes
Nodes	<ul style="list-style-type: none"> User Defined 	
Layout Algorithms	<ul style="list-style-type: none"> Hyperbolic H3 	Comments:
Dimensionality	<ul style="list-style-type: none"> 2D 3D 	Comments:
Visual Enhancements		
Visual Enhancements	<ul style="list-style-type: none"> Distortion 	Comments:
User Interaction		
User Interaction	<ul style="list-style-type: none"> Filter GUI Pan Rotate Zoom 	Comments:
Deployment		
	<u>Type:</u> <ul style="list-style-type: none"> Components for tool building Open Source Standalone Tool 	<u>OS:</u> <ul style="list-style-type: none"> Linux UNIX Windows
Extensibility	<ul style="list-style-type: none"> C++ 	Comments:
Scalability	Max Nodes: Unlimited Max Links: Unlimited	Comments:
	<u>Hardware:</u>	<u>Users:</u>
		<u>Availability:</u> <ul style="list-style-type: none"> Freeware Unsupported
Cost	Free - For noncommercial use	Comments:

<p>Images</p>	
<p>Last Modified</p>	<p>2006-12-18 19:07:15</p>

<p>Name</p>	<p>HP Openview Network Node Manager</p>	
<p>URL</p>	<p>http://h20229.www2.hp.com/products/nnm/index.html</p>	
<p>Description</p>	<p>Brief description: Network Node Manager is a network management tool that provides automatic network discovery to mapping.</p> <p>Detailed description: Features: * Automatic discovery and inventory of your physical network, virtual network services, and the complex relationships between them * Quick identification and assessment of problems and their impact * Built-in intelligence, targeted polling, and automated actions * Support of new services and technology through NNM Advanced Edition Smart Plug-ins</p>	
<p>Product Version/Status</p>	<p>7.51</p>	
<p>Context</p>		
<p>Main Functionalities</p>	<ul style="list-style-type: none"> Automated Layout Graph Manipulation Graph Viewing Network 	<p>Comments:</p>

	managment/discovery	
<u>Domain</u>	<ul style="list-style-type: none"> • Computer Networks 	Comments:
	<u>User Role:</u>	<u>Activity:</u> <ul style="list-style-type: none"> • Monitor • Track
Network Representation		
<u>Links</u>	<ul style="list-style-type: none"> • Labelled 	Comments: Object attribues (not a complete list): <ul style="list-style-type: none"> • hostname • address • status • description • owner
<u>Nodes</u>	<ul style="list-style-type: none"> • Labelled • Pre-Defined Attributes (see comments) • Symbol 	
<u>Layout Algorithms</u>	<ul style="list-style-type: none"> • Bus • Circular • Grid • Random • Star/Symmetric 	Comments: Automatic discovery of layer 2 and 3 devices
<u>Dimensionality</u>	<ul style="list-style-type: none"> • 2D 	Comments:
Analysis		
<u>General Analysis</u>	<ul style="list-style-type: none"> • Trend Analysis 	Comments:
<u>Visual Abstraction</u>	<ul style="list-style-type: none"> • Chart:Line • Chart:Pie 	Comments: Performance data
User Interaction		
<u>User Interaction</u>	<ul style="list-style-type: none"> • Add/Delete • GUI • Pan • Undo/Redo • Web/CGI • Zoom 	Comments:
Deployment		
	<u>Type:</u> <ul style="list-style-type: none"> • Standalone Tool 	<u>OS:</u> <ul style="list-style-type: none"> • HP-UX • Solaris • Windows • Windows 2000 • Windows 2003 • Windows XP
<u>OS Comments/</u>	Microsoft Windows: Server 2000, XP Professional, Server 2003,	

Dependencies	or Server 2003 R2 Sun Solaris 8, 9, or 10 HP-UX 11.0, 11.11, or 11iv2	
	Hardware:	Users: <ul style="list-style-type: none"> • Multiple • Networked
		Availability: <ul style="list-style-type: none"> • Commercially Available
Cost	\$5001 - ∞	Comments:



Images	<p>The screenshot shows a network diagram in a window titled '15.2.112.Segment31'. The diagram features a central node labeled '5uc7uxy1' with a blue square icon. It is connected to several other nodes: 'HP-4F7570' (green square) above, 'HP-7A14A0' (green square) to the left, 'dressage' (HP-UX laptop icon) to the right, 'trout' (HP-UX laptop icon) below-left, 'coach' (HP-UX laptop icon) below, and 'nmrules' (AMD laptop icon) below-right. Various ports (Port 9, Port 11, Port 25, Port 21, Port 2) and network interfaces (lan0) are also labeled. The interface includes a menu bar (Map, Edit, View, Performance, Configuration, Fault, Tools, Options, Window, Help) and a toolbar with icons for home, back, forward, search, and other functions.</p>
Last Modified	2006-12-16 17:35:36

Name	HyperGraph
URL	http://hypergraph.sourceforge.net/
Description	<p>Brief description: HyperGraph is an open source project which provides java code to work with hyperbolic geometry and especially with hyperbolic trees.</p> <p>Detailed description:</p>

Product Version/Status	0.6.3 October 24, 2005	
Context		
Main Functionalities	<ul style="list-style-type: none"> Automated Layout Graph Viewing 	Comments:
Domain	<ul style="list-style-type: none"> Any 	Comments:
Network Representation		
Layout Algorithms	<ul style="list-style-type: none"> Hyperbolic Tree MDS Random Tree 	Comments:
Deployment		
	Type: <ul style="list-style-type: none"> Open Source - GPL Standalone Tool 	OS:
Interoperability	Reads GraphXML files.	
Last Modified		
	2006-12-14 21:18:48	

Name	Hypertree	
URL	http://www.kinase.com/tools/HyperTree.htm	
Description	Brief description: Hypertree is a phylogenetic tree viewer, with a hyperbolic ('fish-eye') view and editing abilities that help in managing very large trees. Detailed description:	
Context		
Main Functionalities	<ul style="list-style-type: none"> Automated Layout Graph Manipulation Graph Viewing 	Comments:
Domain	<ul style="list-style-type: none"> Any 	Comments:
Network Representation		
Links	<ul style="list-style-type: none"> Coloured Labelled 	Comments:
Nodes	<ul style="list-style-type: none"> Coloured 	

	<ul style="list-style-type: none"> • Labelled 	
Layout Algorithms	<ul style="list-style-type: none"> • Hyperbolic Tree 	Comments:
User Interaction		
User Interaction	<ul style="list-style-type: none"> • Add/Delete • Cut & Paste • Drag & Drop • GUI • Rotate • Zoom 	Comments:
Deployment		
	<p>Type:</p> <ul style="list-style-type: none"> • Standalone Tool 	<p>OS:</p> <ul style="list-style-type: none"> • Linux • Mac OS X • UNIX • Windows
	Hardware:	<p>Users:</p> <p>Availability:</p> <ul style="list-style-type: none"> • Freeware
Cost	Free - For noncommercial use	Comments:
Last Modified		
	2006-12-18 19:07:41	

Name	HyperTree Java Library	
URL	http://hypertree.sourceforge.net/	
Description	<p>Brief description: A hyperbolic tree visualization java library, to implement hyperbolic tree easily.</p> <p>Detailed description:</p>	
Product Version/Status	0.9 (2001-09-04 15:00)	
Network Representation		
Layout Algorithms	<ul style="list-style-type: none"> • Hyperbolic Tree 	Comments:
Dimensionality	<ul style="list-style-type: none"> • 2D 	Comments:
Deployment		
	<p>Type:</p> <ul style="list-style-type: none"> • Components for tool building 	<p>OS:</p> <ul style="list-style-type: none"> • Multi-Platform (JAVA)

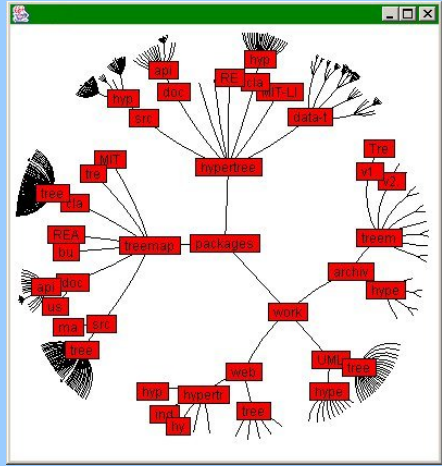
Extensibility	<ul style="list-style-type: none"> JAVA 	Comments:
Cost	Free	Comments:
Images		
Last Modified	2006-12-10 16:39:16	

Name	IBM Tivoli NetView	
URL	http://www-306.ibm.com/software/tivoli/products/netview/	
Description	<p>Brief description: Tivoli NetView discovers TCP/IP networks, displays network topologies, correlates and manages events and SNMP traps, monitors network health, and gathers performance data.</p> <p>Detailed description:</p>	
Context		
Main Functionalities	<ul style="list-style-type: none"> Automated Layout Graph Manipulation Graph Viewing Network management/discovery 	Comments:
Domain	<ul style="list-style-type: none"> Computer Networks 	Comments:
	<p>User Role:</p>	<p>Activity:</p> <ul style="list-style-type: none"> Monitor Track
Network Representation		
Layout Algorithms	<ul style="list-style-type: none"> Bus Orthogonal 	Comments:

	<ul style="list-style-type: none"> Star/Symmetric Tree 	
<u>Dimensionality</u>	<ul style="list-style-type: none"> 2D Geospatial 	Comments:
Analysis		
<u>Network Analysis</u>	<ul style="list-style-type: none"> Traffic Analysis 	Comments:
<u>Visual Abstraction</u>	<ul style="list-style-type: none"> Chart:Line 	Comments: Data that can be graphed: -Interface Traffic -Interface Half-duplex Utilization -Interface Full-duplex Send Utilization -Interface Full-duplex Receive Utilization -Interface Send Error Rate -Interface Receive Error Rate -SNMP Traffic -SNMP Operations -SNMP Errors -ICMP Traffic -IP Traffic -Graph Data -Graph Data All -Interface Traffic -Collected Data
User Interaction		
<u>User Interaction</u>	<ul style="list-style-type: none"> Add/Delete Cut & Paste GUI Pan Reposition Scroll Select Undo/Redo Web/CGI Zoom 	Comments: Users can view network information from any supported Web browser.
Deployment		
	<u>Type:</u> <ul style="list-style-type: none"> Standalone Tool 	<u>OS:</u> <ul style="list-style-type: none"> AIX Solaris UNIX Windows 2000
	<u>Hardware:</u>	<u>Users:</u> <ul style="list-style-type: none"> Multiple Networked
		<u>Availability:</u> <ul style="list-style-type: none"> Commercially Available

<p>Images</p>	
<p>Last Modified</p>	<p>2006-12-16 17:36:01</p>

<p>Name</p>	<p>igraph</p>
<p>URL</p>	<p>http://cneurocvs.rmki.kfki.hu/igraph/</p>
<p>Description</p>	<p>Brief description: igraph is a library for creating and manipulating graphs.</p> <p>Detailed description: Features</p> <ul style="list-style-type: none"> • igraph contains functions for generating regular and random graphs according to known algorithms and models in the network theory literature. • igraph provides routines for manipulating graphs, adding and removing edges and vertices. • a set of structural property calculation functions like degree, betweenness, etc. are also included. • force based layout generators are included for smaller graphs, another method is expected to be added for large graphs soon. • a set of conversion functions are also included and will be extended shortly. • igraph iterators provide a simple and efficient way of walking through graphs. • igraph is well documented both for users and developers. • igraph is open source and distributed under GNU GPL.
<p>Product Version/Status</p>	<p>0.2.1 (Released Aug 23, 2006)</p>

Context		
<u>Main Functionalities</u>	<ul style="list-style-type: none"> Automated Layout Graph Manipulation Graph Viewing Network Analysis 	Comments:
<u>Domain</u>	<ul style="list-style-type: none"> Any 	Comments:
Network Representation		
<u>Type</u>	<ul style="list-style-type: none"> Directed Undirected 	
<u>Links</u>	<ul style="list-style-type: none"> User Defined 	Comments:
<u>Nodes</u>	<ul style="list-style-type: none"> User Defined 	
<u>Layout Algorithms</u>	<ul style="list-style-type: none"> Circular Force-Directed Grid Hierarchical (Reingold-Tilford) Random Spherical Spring FR Spring KK 	Comments:
<u>Dimensionality</u>	<ul style="list-style-type: none"> 2D 3D 	Comments:
Analysis		
<u>General Analysis</u>	<ul style="list-style-type: none"> Data Transformation:Direction 	Comments:
<u>Network Analysis</u>	<ul style="list-style-type: none"> Centrality:Betweenness Centrality:Closeness Centrality:Edge Betweenness Centrality:PageRank Clustering Connection:All Pairs Shortest Path Connection:Decompose Connection:Is Connected Connection:Minimal Spanning Tree Connection:Shortest Path Diameter 	Comments:
Deployment		
	<u>Type:</u> <ul style="list-style-type: none"> Components for tool building Open Source - GPL 	<u>OS:</u> <ul style="list-style-type: none"> Linux UNIX Windows

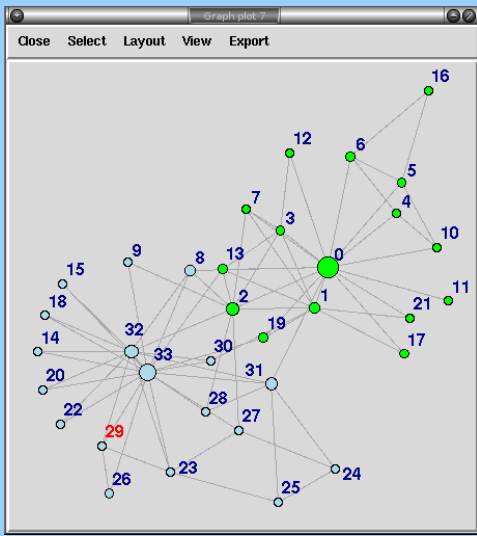
OS Comments/Dependencies	For compiling igraph from source you'll need a fairly modern C compiler and some standard unix tools: sed, touch, chmod, etc. GNU bison is also needed, at least version 1.35 or newer.	
	Cygwin is required for operation under Windows.	
Extensibility	<ul style="list-style-type: none"> • C • Python 	Comments:
Interoperability	read/write GraphML and Pajek file formats as well simple edge list formats	
	Hardware:	Users: <ul style="list-style-type: none"> • Freeware • In Development
Availability:		
Cost	Free	Comments:
Images		
Last Modified	2006-12-10 16:39:16	

Name	ILOG JViews Diagrammer
URL	http://www.ilog.com/products/jviews/diagrammer/
Description	<p>Brief description: ILOG JViews Diagrammer provides a collection of algorithms and tools for graph presentation and manipulation.</p> <p>Detailed description: JViews Diagrammer is a set of Java components, tools and libraries for creating diagram-based editing, visualization, supervision and monitoring tools. Also includes JViews Maps, Military Maps, and Telecommunications Objects.</p>
Context	

<u>Main Functionalities</u>	<ul style="list-style-type: none"> Automated Layout Graph Manipulation Graph Viewing 	Comments:
<u>Domain</u>	<ul style="list-style-type: none"> Any 	Comments:
Network Representation		
<u>Links</u>	<ul style="list-style-type: none"> User Defined 	Comments: Any JAVA data type can be used for link/node attributes
<u>Nodes</u>	<ul style="list-style-type: none"> User Defined 	
<u>Layout Algorithms</u>	<ul style="list-style-type: none"> Circular Hierarchical Incremental Spring Topological mesh Tree 	Comments: ILOG JViews Diagrammer offers over a dozen different link styles, from simple straight-line connections to splines and complex polylines. Each algorithm possesses a full set of parameters, allowing users to fine-tune behavior. Typical options include layout direction (left to right, top to bottom); minimum spacing between nodes, links and labels; and maximum time allowed for a solution search.
<u>Dimensionality</u>	<ul style="list-style-type: none"> 2D 	Comments:
Visual Enhancements		
<u>Visual Enhancements</u>	<ul style="list-style-type: none"> Animation/Video 	Comments:
User Interaction		
<u>User Interaction</u>	<ul style="list-style-type: none"> Add/Delete Cut & Paste Drag & Drop GUI Layers Pan Undo/Redo Web/CGI Zoom 	Comments: LOG JViews Diagrammer includes complete interactive editing capabilities. Editing functions include: <ul style="list-style-type: none"> - Creation-and-modification tools for nodes and links - Zoom-and-pan tools - Overview windows to control how much of the diagram is visible - Logical zooming to hide or show layers of information, such as labels - Drag-and-drop, cut-and-paste, undo-redo - Layout animation - Incremental layout ensures that small changes do not force large diagram rearrangements
Deployment		
	<u>Type:</u> <ul style="list-style-type: none"> Components for tool building Web-based 	<u>OS:</u> <ul style="list-style-type: none"> Multi-Platform (JAVA)
<u>Extensibility</u>	<ul style="list-style-type: none"> JAVA 	Comments:

		The JViews API provides an extension protocol for customizing any part of the diagramming package. Thus, new algorithms, node/link types, etc. can be added.
<u>Interoperability</u>	<p>Being a language library, other software can interact with JViews either by calling it directly, via a web service, or by some other means.</p> <p>JViews Diagrammer can be used within Eclipse plug-ins based on the standard widget toolkit (SWT) through the Swing/SWT bridge.</p>	
	<u>Hardware:</u>	<u>Users:</u> <u>Availability:</u> <ul style="list-style-type: none"> Commercially Available
Last Modified	2006-12-18 22:40:54	

Name	ILOG Views Graph Layout	
URL	http://www.ilog.com/products/views/graphlayout/	
Description	<p>Brief description: ILOG Views Graph Layout provides a collection of algorithms and tools for graph presentation and manipulation.</p> <p>Detailed description: ILOG Views Graph Layout provides a collection of algorithms for network and diagram presentation. These algorithms are useful for relationship presentation, and compute positions of links, nodes, or both -- presenting a readable view of the data.</p> <p>Applications can be deployed as interactive editors, Web servers or administration tools. For instance, ILOG Views Graph Layout can be used to represent workflow diagrams, business organizational charts, PERT charts or telecommunications networks.</p>	
<u>Product Version/Status</u>	Ilog JViews 6.5 Currently Supported.	
Context		
<u>Main Functionalities</u>	<ul style="list-style-type: none"> Automated Layout Graph Manipulation Graph Viewing 	Comments:
<u>Domain</u>	<ul style="list-style-type: none"> Any 	Comments:
Network Representation		
<u>Links</u>	<ul style="list-style-type: none"> User Defined 	Comments:
<u>Nodes</u>	<ul style="list-style-type: none"> User Defined 	
<u>Layout Algorithms</u>	<ul style="list-style-type: none"> Circular Force-Directed 	Comments: Nested graphs are also supported.

	<ul style="list-style-type: none"> • Hierarchical • Radial Tree • Spring • Starburst 	
<u>Dimensionality</u>	<ul style="list-style-type: none"> • 2D • Geospatial 	Comments:
Visual Enhancements		
<u>Visual Enhancements</u>	<ul style="list-style-type: none"> • Animation/Video 	Comments:
User Interaction		
<u>User Interaction</u>	<ul style="list-style-type: none"> • Add/Delete • Cut & Paste • Drag & Drop • Draw • Drill down • GUI • Layers • Pan • Reposition • Resize • Rotate • Scroll • Undo/Redo • Web/CGI • Zoom 	Comments: Applications can be deployed to Web servers and viewed using a browser via thin clients:
Deployment		
	<u>Type:</u> <ul style="list-style-type: none"> • Components for tool building 	<u>OS:</u> <ul style="list-style-type: none"> • Linux • UNIX • Windows
<u>Extensibility</u>	<ul style="list-style-type: none"> • C++ • Javascript 	Comments: C++ API features an extension protocol for customizing any part of diagramming application, including: <ul style="list-style-type: none"> * Connection to data * New algorithms * New types of node and links * Interactions User scripting: <ul style="list-style-type: none"> * Allows on-site customization of applications without recompilation * Provides an implementation of JavaScript * Graphic objects, positions, properties and functions can be modified or called

Interoperability	Oracle Spatial, ShapeFile, MID/MIF, DTED, CADRG, GeoTIFF, GIF and JPEG	
	Hardware:	Users: Availability: <ul style="list-style-type: none"> Commercially Available
Cost	unknown	Comments: Requires quote.
Images		
Last Modified	2006-12-18 22:56:44	

Name	InFlow	
URL	http://www.orgnet.com/	
Description	<p>Brief description: InFlow is a software based, organization network analysis methodology that maps and measures knowledge exchange, information flow, communities of practice, networks of alliances and other networks within and between organizations.</p> <p>Detailed description:</p>	
Context		
Domain	<ul style="list-style-type: none"> Social Networks 	Comments:
Network Representation		
Dimensionality	<ul style="list-style-type: none"> 2D 	Comments:
Analysis		
General Analysis	<ul style="list-style-type: none"> Statistics:Cluster 	Comments:
Network Analysis	<ul style="list-style-type: none"> Centrality Centrality:Information Cluster Recognition Cohesion:Density Connection:Influence 	Comments:

	<ul style="list-style-type: none"> • Connection:Shortest Path • Equivalence:Structural 	
Deployment		
	Type: <ul style="list-style-type: none"> • Standalone Tool 	OS:
Last Modified		
2006-12-10 16:39:16		

Name	InfoVis Toolkit
URL	http://ivtk.sourceforge.net/
Description	<p>Brief description: The InfoVis toolkit is a software package aimed at simplifying the development of Information Visualization Systems. It is written in Java, capitalizing on its rich interactive graphics environment and portability</p> <p>Detailed description:</p>
Product Version/Status	Version 0.9beta2, July 17, 2006

Context		
Main Functionalities	<ul style="list-style-type: none"> • Automated Layout • Graph Manipulation • Graph Viewing • Network Analysis 	Comments:
Domain	<ul style="list-style-type: none"> • Any 	Comments:

Network Representation		
Layout Algorithms	<ul style="list-style-type: none"> • Circular • Clustered • Random • Spring • Spring FR • Tree 	Comments:
Dimensionality	<ul style="list-style-type: none"> • 2D 	Comments:

Analysis		
Network Analysis	<ul style="list-style-type: none"> • Cohesion:k-Core • Connection:Shortest Path • Traversal:Breadth First Search • Traversal:Depth First Search 	Comments:

Visual Abstraction	<ul style="list-style-type: none"> • Chart:Scatter 	Comments:
Visual Enhancements		
Visual Enhancements	<ul style="list-style-type: none"> • Distortion 	Comments: Fisheye
Deployment		
	Type: <ul style="list-style-type: none"> • Components for tool building • Open Source - GPL 	OS: <ul style="list-style-type: none"> • Multi-Platform (JAVA)
Extensibility	<ul style="list-style-type: none"> • JAVA 	Comments:
Interoperability	Import/Export for the following formats: DOT GraphML XML Pajek VCG	
	Hardware:	Users: Availability: <ul style="list-style-type: none"> • Freeware • In Development
Cost	Free	Comments:

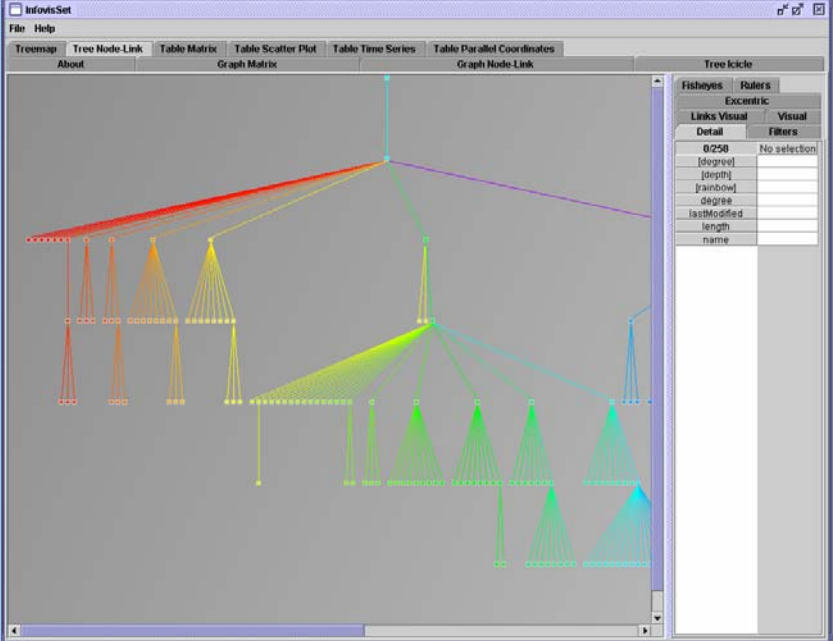

Images	
---------------	--

	
References	JavaDocs http://ivtk.sourceforge.net/api/index.html
Last Modified	2006-12-10 16:39:16

Name	Inxight StarTree	
URL	http://www.inxight.com/products/sdks/st/	
Description	<p>Brief description: Inxight StarTree, also known as the Hyperbolic Tree, enables you to link files, documents and Web pages across applications and network boundaries. It provides a visual context for information, showing at-a-glance hierarchical or network relationships.</p> <p>Detailed description:</p>	
Context		
Main Functionalities	<ul style="list-style-type: none"> Automated Layout Graph Manipulation Graph Viewing 	Comments:
Domain	<ul style="list-style-type: none"> Any 	Comments:
Network Representation		
Links	<ul style="list-style-type: none"> Coloured Pre-Defined Attributes (see comments) Traffic 	Comments: In addition to using link colour to denote particular relationships between nodes, line thickness can also be used to indicate traffic or

<u>Nodes</u>	<ul style="list-style-type: none"> • Coloured • Labelled • Symbol • User Defined 	<p>capacity.</p> <p>Nodes can be products in a catalog, persons in an organization, pages in a Web site, documents in a collection and so on. Node can also have dynamic indicators (i.e. thermometer) to visually convey information about the node.</p>
<u>Layout Algorithms</u>	<ul style="list-style-type: none"> • Hyperbolic Tree 	Comments:
<u>Dimensionality</u>	<ul style="list-style-type: none"> • 2D 	Comments:
User Interaction		
<u>User Interaction</u>	<ul style="list-style-type: none"> • Drill down • Focus • GUI • Tool Tips • Web/CGI 	Comments:
Deployment		
	<u>Type:</u> <ul style="list-style-type: none"> • Standalone Tool 	<u>OS:</u>
<u>Extensibility</u>	<ul style="list-style-type: none"> • .NET • JAVA 	Comments: APIs are provided in an SDK
<u>Interoperability</u>		
	<u>Hardware:</u>	<u>Users:</u>
		<u>Availability:</u> <ul style="list-style-type: none"> • Commercially Available
		

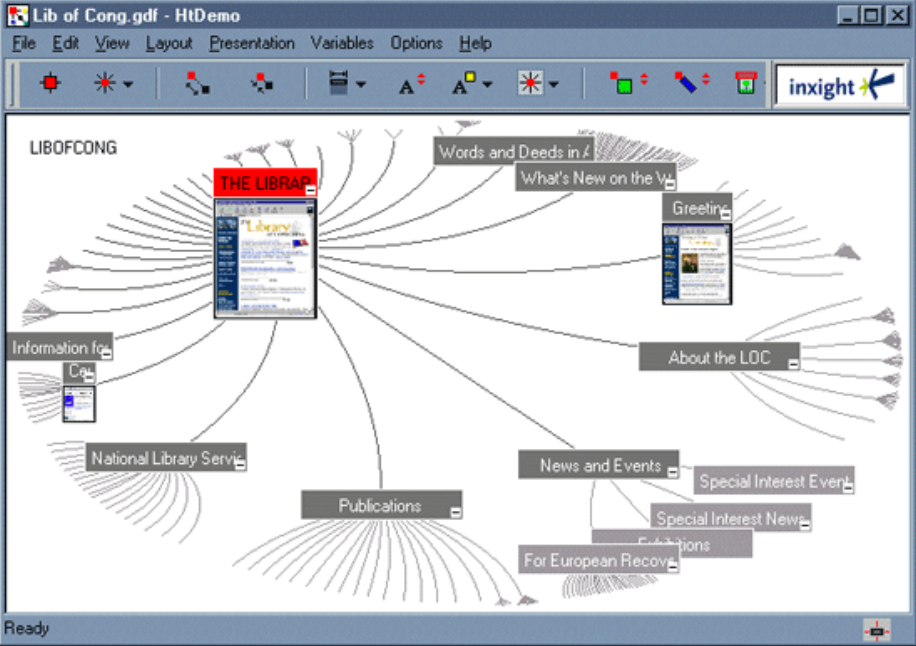
<p>Images</p>	
<p>Last Modified</p>	<p>2006-12-18 19:08:21</p>

<p>Name</p>	<p>IPsonar</p>
<p>URL</p>	<p>http://www.lumeta.com/solutions/ipsonar.asp</p>
<p>Description</p>	<p>Brief description: IPsonar provides a complete view of IT infrastructure, discovering routers, hosts, servers, wireless access points, operating system information, unauthorized connections or hosts, and perimeter leaks. IPsonar can then produce a set of comprehensive maps.</p> <p>Detailed description: IPsonar consists of a server and distributed sensors. These sensors send rate controlled packets to scan the network and collect data on the connected devices (scanning rates are user configurable). The sensors then forward their data via SSL-encrypted tunnels to the IPsonar server for analysis and report generation.</p> <p>The IPsonar server contains a local sensor; however, distributed sensors can provide a more complete view of the network. The IPsonar performs analysis on data received from three different scans completed by the IPsonar sensors: Network Discovery (ND), Leak Discovery (LD), and Server Discover(SD).</p> <p>Based on these scans, the IPsonar Server generates several "out-of-the-box" reports:</p> <ul style="list-style-type: none"> - Executive summary - Anomalies - Scan Comparisons - Maps - Network - Devices

Product Version/Status	3.8	
Context		
Main Functionalities	<ul style="list-style-type: none"> Automated Layout Graph Manipulation Graph Viewing Network Analysis Network management/discovery 	Comments:
Domain	<ul style="list-style-type: none"> Computer Networks 	Comments:
	User Role:	Activity: <ul style="list-style-type: none"> Investigate Monitor Track
Network Representation		
Layout Algorithms		Comments: Included with IPsonar is Lumeta MapViewer. MapViewer integrates information visualization with interaction and query capabilities to explore the information that the visualizations reveal. Users can explore large quantities of data and discover relationships and patterns that lead to proactive decision making.
Dimensionality	<ul style="list-style-type: none"> 2D 	Comments:
Analysis		
Network Analysis	<ul style="list-style-type: none"> Perimeter Analysis 	Comments:
User Interaction		
User Interaction	<ul style="list-style-type: none"> Drill down Filter GUI Web/CGI 	Comments:
Deployment		
	Type: <ul style="list-style-type: none"> Standalone Tool Web-based 	OS: <ul style="list-style-type: none"> Hardware Appliance
OS Comments/Dependencies	IPsonar software is pre-loaded onto hardware for use on customer network.	
Interoperability	Data export for integration with 3rd party solutions	

Hardware:

Users:

Availability:

- Multiple
- Networked

- Commercially Available

Cost

\$5001 - ∞

Comments:

Starting price: \$21,500

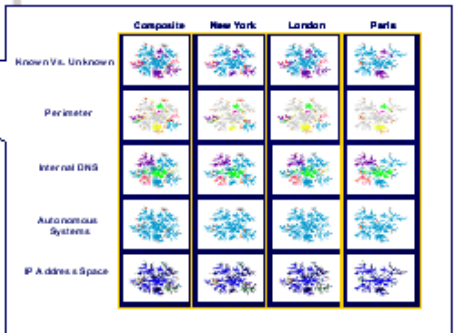
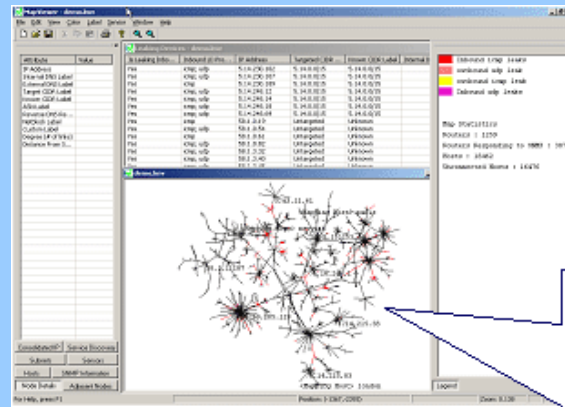

Images

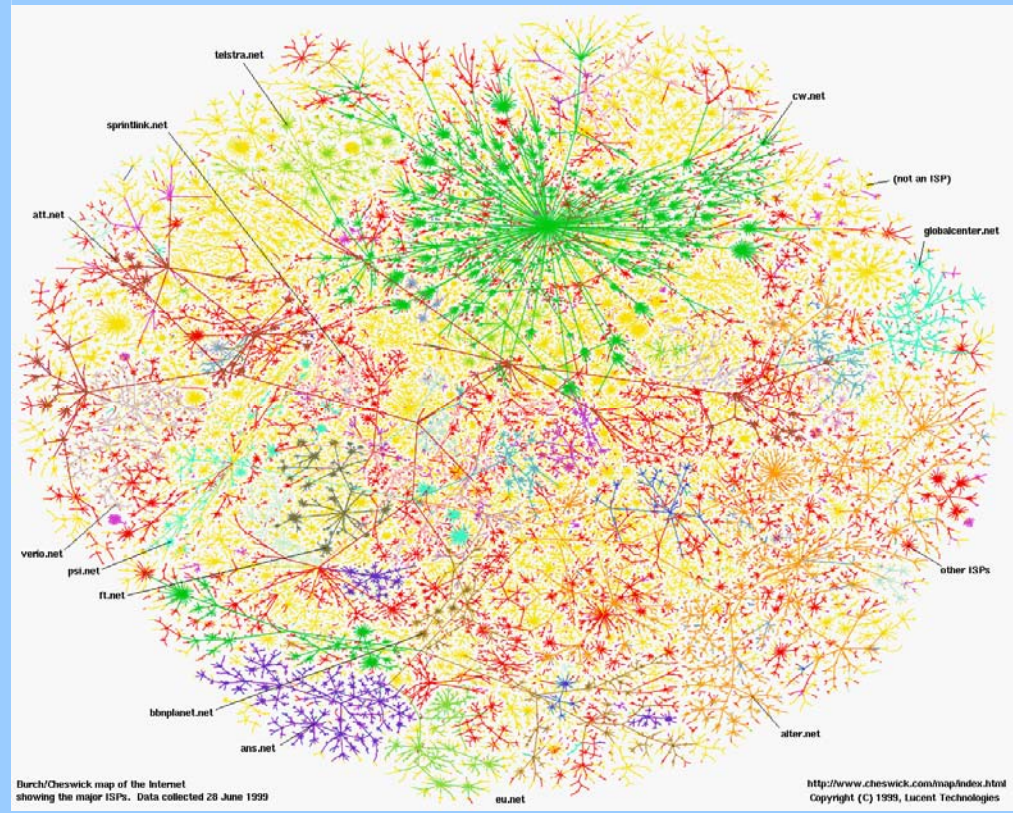

Durch/Cheswick map of the Internet showing the major ISPs. Data collected 28 June 1999

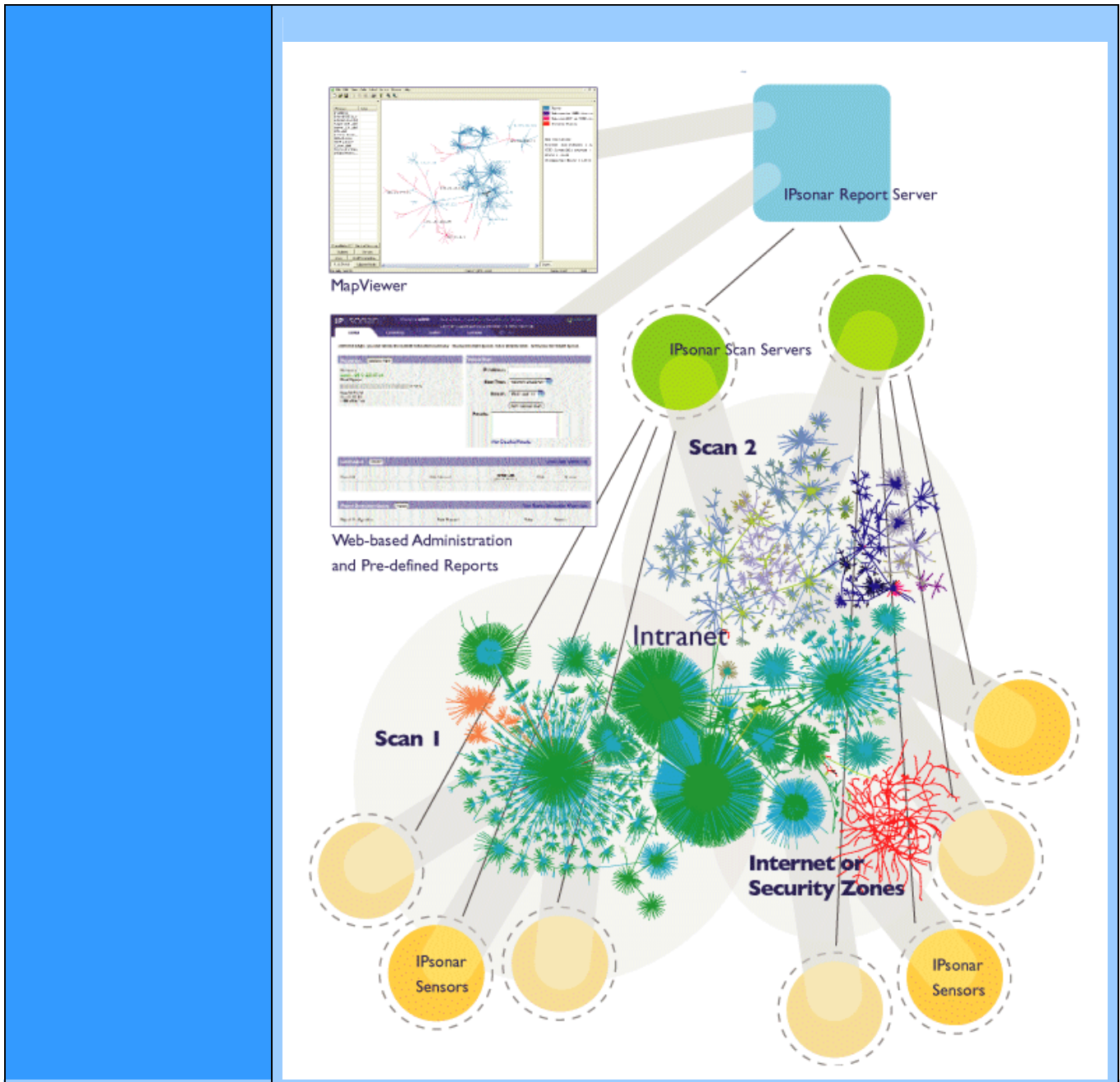

Last Modified	2006-12-18 19:08:37
----------------------	---------------------

Name	IronView Network Manager
URL	http://www.foundrynet.com/products/net-mgmt/inm.html
Description	<p>Brief description: Foundry IronView Network Manager (INM) provides network administrators with tools for configuring, managing, monitoring, and securing Foundry's line of network equipment.</p> <p>Detailed description:</p>

Context		
<u>Main Functionalities</u>	<ul style="list-style-type: none"> Automated Layout Graph Manipulation Graph Viewing Network Analysis Network management/discovery 	Comments: Seems to be limited to discovery and mapping of network equipment sold by Foundry Networks.
<u>Domain</u>	<ul style="list-style-type: none"> Computer Networks 	Comments:
	<u>User Role:</u>	<u>Activity:</u> <ul style="list-style-type: none"> Monitor Track
Network Representation		
<u>Layout Algorithms</u>	<ul style="list-style-type: none"> Hierarchical Radial Tree Tree 	Comments:
<u>Dimensionality</u>	<ul style="list-style-type: none"> 2D 	Comments:
Analysis		
<u>Network Analysis</u>	<ul style="list-style-type: none"> Flow Analysis Packet Analysis Traffic Analysis 	Comments: Ironview can convert its collected data for analysis by the Open Source Snort intrusion detection software package.
<u>Visual Abstraction</u>	<ul style="list-style-type: none"> Chart:Bar Chart:Pie 	Comments: The INM dashboard shows the status of Foundry devices, including asset views, status and alarms, as well as INM status. Dashboard views include a wired and wireless device status pie chart and an inventory bar graph showing the number and family type of each Foundry device discovered. An event summary bar chart shows the number and type of events for each severity defined by INM, and event types include traps, internal INM events, security and syslog events. This bar graph can show the event summary for the last 24 hours, 7 days, or 30 days.
User Interaction		
<u>User Interaction</u>	<ul style="list-style-type: none"> GUI Web/CGI 	Comments:
Deployment		

	<p>Type:</p> <ul style="list-style-type: none"> • Standalone Tool • Web-based <p>OS:</p> <ul style="list-style-type: none"> • Linux • Solaris • Windows 2003 • Windows XP
OS Comments/Dependencies	<p>Server Requirements: Windows 2003 (SP1) Windows XP (SP2) Solaris 9 or 10 Red Hat Enterprise Linux WS Release 3-4</p> <p>Browser requirements (for web-based components): IE 6.0 and above or Firefox 1.5 JRE-1.5.0_07</p>
Interoperability	Export data to Snort for further analysis
	<p>Hardware:</p> <p>Users:</p> <ul style="list-style-type: none"> • Multiple • Networked <p>Availability:</p> <ul style="list-style-type: none"> • Commercially Available

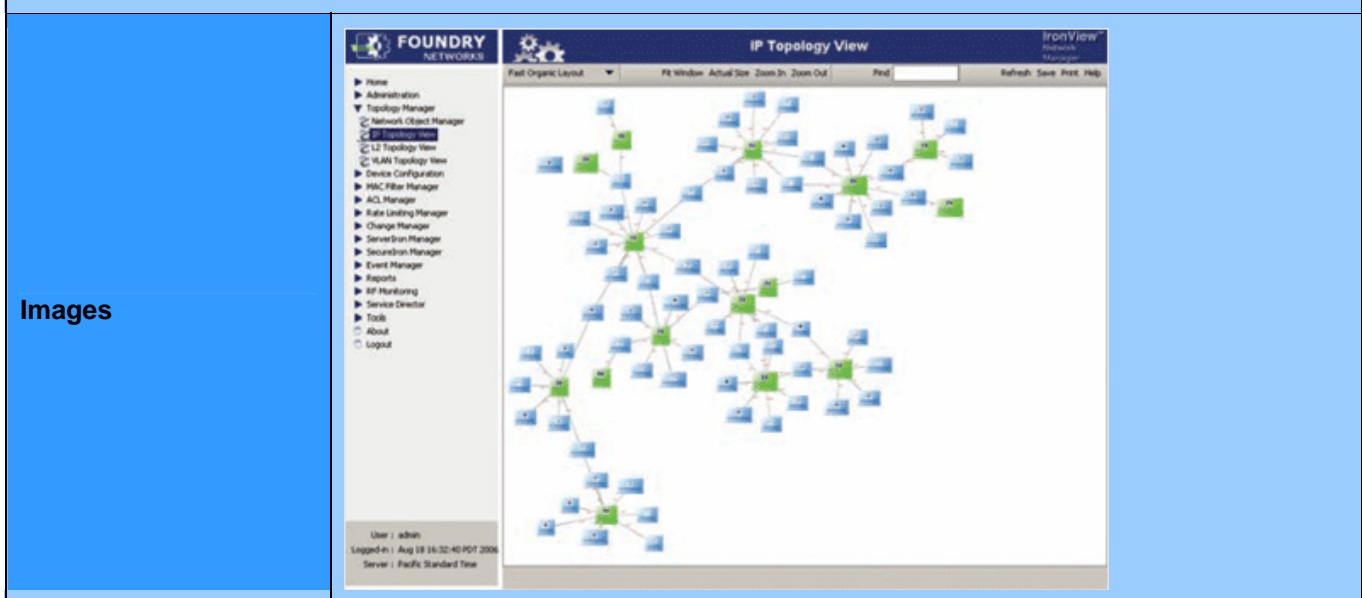

Last Modified	2006-12-18 19:09:30
----------------------	---------------------

Name	IVC - Information Visualization CyberInfrastructure
URL	http://iv.slis.indiana.edu/sw/
Description	<p>Brief description: The Information Visualization Cyberinfrastructure Software Framework (IVCSF) is a</p>

	<p>software framework developed using Eclipse RCP that allows diverse algorithms to be plugged-in and run as independent software components.</p> <p>Detailed description: While the algorithms might be developed by different researchers and implemented in different programming languages (e.g., Java, Perl, C, C++) using different graphics, math or other packages the IVC framework facilitates the seamless integration of those algorithms into a unified software package. The IVC framework is unique in that it places no restrictions on the type of data structures, algorithms or persistent data formats. By separating out functions such as data load and store, graphical user interface, transaction logging and inter-convertibility between data formats, the IVC lets a programmer concentrate on developing the core code and frees her from issues such as loading the data into the a particular data structure or keeping track of changing results over time.</p>	
Product Version/Status	1.0.4 (2005-11-01)	
Context		
Main Functionalities	<ul style="list-style-type: none"> Automated Layout Graph Manipulation Graph Viewing Network Analysis 	Comments:
Domain	<ul style="list-style-type: none"> Any 	Comments:
Network Representation		
Layout Algorithms	<ul style="list-style-type: none"> Clustered Hyperbolic Tree Parallel Coordinates Radial Tree Spring 	Comments:
Dimensionality	<ul style="list-style-type: none"> 2D 	Comments:
Analysis		
General Analysis	<ul style="list-style-type: none"> Statistics:MDS 	Comments:
Network Analysis	<ul style="list-style-type: none"> Pathfinder Network Scaling Traversal:Breadth First Search Traversal:k Random-Walk Search 	Comments:
Visual Enhancements		
Visual Enhancements	<ul style="list-style-type: none"> Distortion 	Comments:
User Interaction		
User Interaction	<ul style="list-style-type: none"> GUI Pan Zoom 	Comments: Zoom/Panning Distortion Fisheye Table

Deployment		
	<p>Type:</p> <ul style="list-style-type: none"> • Components for tool building • Open Source 	<p>OS:</p> <ul style="list-style-type: none"> • Linux • Mac OS X • Multi-Platform (JAVA) • UNIX • Windows
Extensibility	<ul style="list-style-type: none"> • JAVA 	Comments:
	<p>Hardware:</p>	<p>Users:</p>
		<p>Availability:</p> <ul style="list-style-type: none"> • Freeware • In Development
Cost	Free	<p>Comments:</p> <p>Released under Apache License Version 2.0</p>
Last Modified	2006-12-18 19:09:54	

Name	Java Graph Framework	
URL	http://www.tensegrity-software.com/graph-component.html	
Description	<p>Brief description: With the Graph Framework you have access to a Java library that enables you to create solutions instantly by using the comprehensive and extendable application programming interfaces and provide your application with an appealing and intuitive user interface.</p> <p>Detailed description:</p>	
Context		
Main Functionalities	<ul style="list-style-type: none"> • Automated Layout • Graph Manipulation • Graph Viewing • Network Analysis 	Comments:
Domain	<ul style="list-style-type: none"> • Any 	Comments:
Network Representation		
Links	<ul style="list-style-type: none"> • Coloured • Labelled • User Defined 	Comments:
Nodes	<ul style="list-style-type: none"> • Coloured • Labelled 	

	<ul style="list-style-type: none"> • User Defined 	
<u>Layout Algorithms</u>	<ul style="list-style-type: none"> • Circular • Force-Directed • Grid • Hierarchical • OrgChart • Orthogonal • Radial Tree • Spring • Tree 	Comments:
<u>Dimensionality</u>	<ul style="list-style-type: none"> • 2D 	Comments:
Analysis		
<u>Network Analysis</u>	<ul style="list-style-type: none"> • Connection:Minimal Spanning Tree • Connection:Shortest Path • Topological Sort • Traversal:Breadth First Search • Traversal:Depth First Search 	Comments:
User Interaction		
<u>User Interaction</u>	<ul style="list-style-type: none"> • Add/Delete • Cut & Paste • Grid/Ruler • Groups • GUI • Layers • Resize • Rotate • Undo/Redo • Zoom 	Comments:
Deployment		
	<u>Type:</u> <ul style="list-style-type: none"> • Components for tool building 	<u>OS:</u> <ul style="list-style-type: none"> • Multi-Platform (JAVA)
<u>OS Comments/Dependencies</u>	JDK 1.4, 1.5 Supported browsers: MS Internet Explorer, Netscape Navigator	
<u>Extensibility</u>	<ul style="list-style-type: none"> • JAVA 	Comments: The Graph Designer is offered as a sample application to demonstrate the graph framework. Many features are implemented which can be modified to suit your needs.
<u>Interoperability</u>	Export: Custom rendering, picture formats, SVG, customized SVG, PDF, ImageMap, and GXL Import: CSV and GXL	

Hardware:

Users:

Availability:

- Commercially Available

Cost

\$5001 - ∞

Comments:

Images

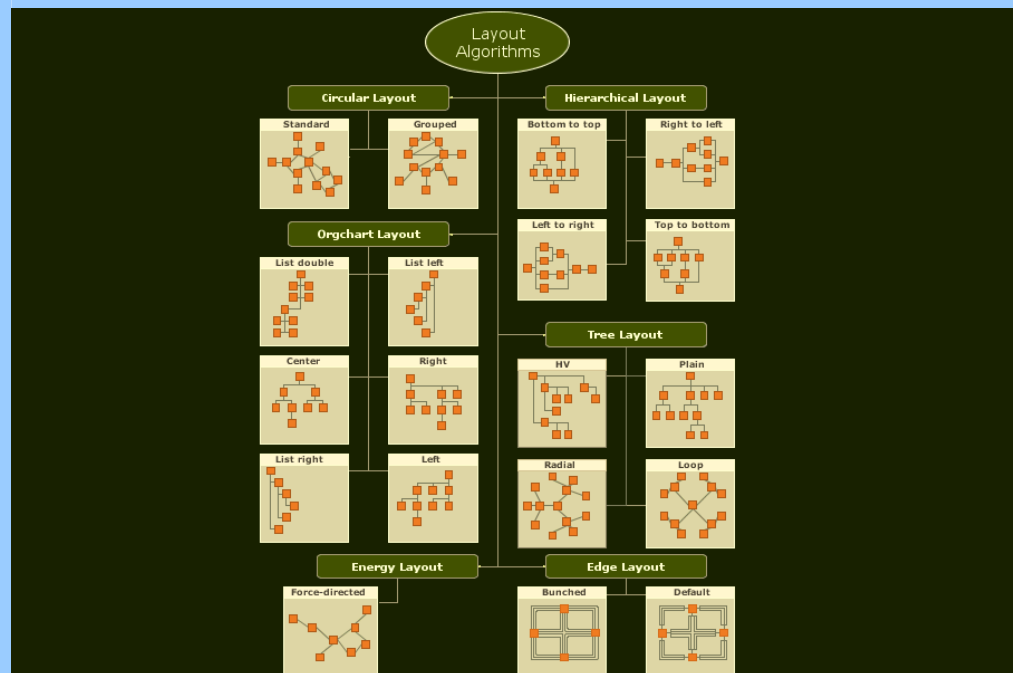
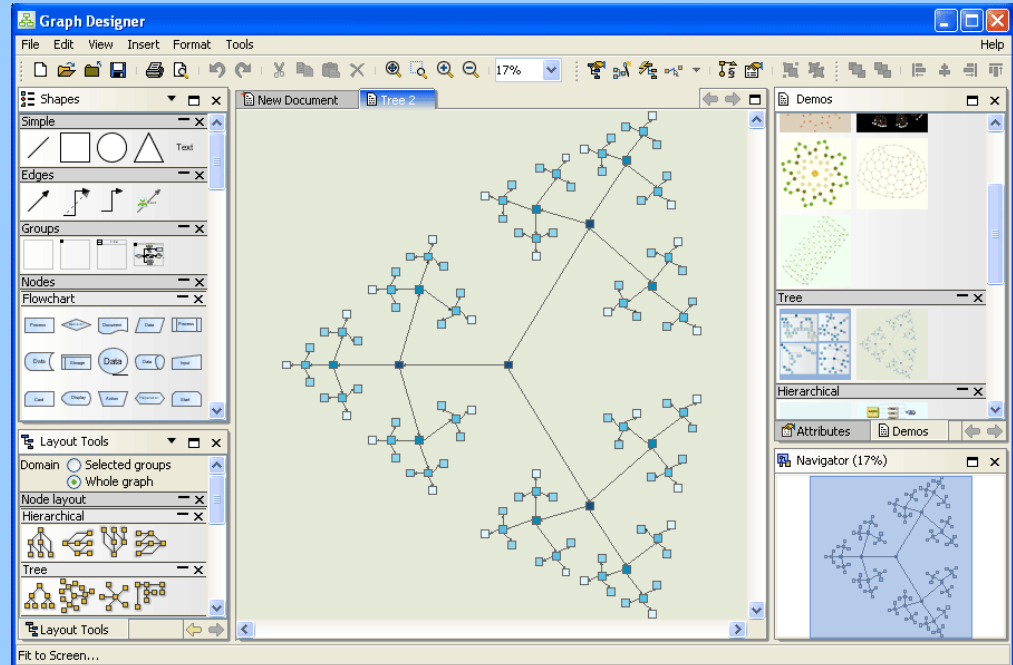

Last Modified

2006-12-10 16:39:16

Name	JDigraph	
URL	https://jdigraph.dev.java.net/	
Description	Brief description: A Java library for visualizing and working with directed graphs and paths Detailed description:	
Product Version/Status	alpha-0-14 April 30, 2006	
Context		
Main Functionalities	<ul style="list-style-type: none"> Automated Layout Graph Viewing 	Comments:
Network Representation		
Type	<ul style="list-style-type: none"> Directed 	
Deployment		
	Type: <ul style="list-style-type: none"> Components for tool building Open Source 	OS: <ul style="list-style-type: none"> Multi-Platform (JAVA)
Extensibility	<ul style="list-style-type: none"> JAVA 	Comments:
	Hardware:	Users: Availability: <ul style="list-style-type: none"> Freeware In Development
Cost	Free	Comments: Released under the BSD license
Last Modified		
2006-12-15 20:10:45		

Name	JGraph and JGraph Layout Pro	
URL	http://www.jgraph.com/	
Description	Brief description: JGraph is a graph visualization library written in JAVA. Detailed description: JGraph enables client-side and server-side application to incorporate a range of graph drawing functions. The JGraph API provides methods for graph visualization, manipulation, and layout.	

Product Version/Status	5.2.9.1	
Context		
Main Functionalities	<ul style="list-style-type: none"> Automated Layout Graph Manipulation Graph Viewing Network Analysis 	Comments:
Domain	<ul style="list-style-type: none"> Any 	Comments:
Network Representation		
Layout Algorithms	<ul style="list-style-type: none"> Circular Hierarchical Inverted Self Organising Map Radial Tree Spring Tree 	Comments:
Dimensionality	<ul style="list-style-type: none"> 2D 	Comments:
User Interaction		
User Interaction	<ul style="list-style-type: none"> Add/Delete Clone Drag & Drop GUI Resize Zoom 	Comments: The JGraph GUI supports graph editing tools such as: dragging and cloning cells, re-sizing and reshaping, connecting and disconnecting, drag and dropping from external sources, editing cell labels in-place and more.
Deployment		
	Type: <ul style="list-style-type: none"> Components for tool building Open Source OS:	
Extensibility	<ul style="list-style-type: none"> JAVA 	Comments: Since JGraph is open source any custom algorithms can be added as needed.
Interoperability	File export: SVG, JPG, PNG, BMP	
	Hardware:	Users: Availability: <ul style="list-style-type: none"> Commercially Available Freeware In Development
Cost	\$101 - \$1000	Comments: http://www.jgraph.com/purchase.html

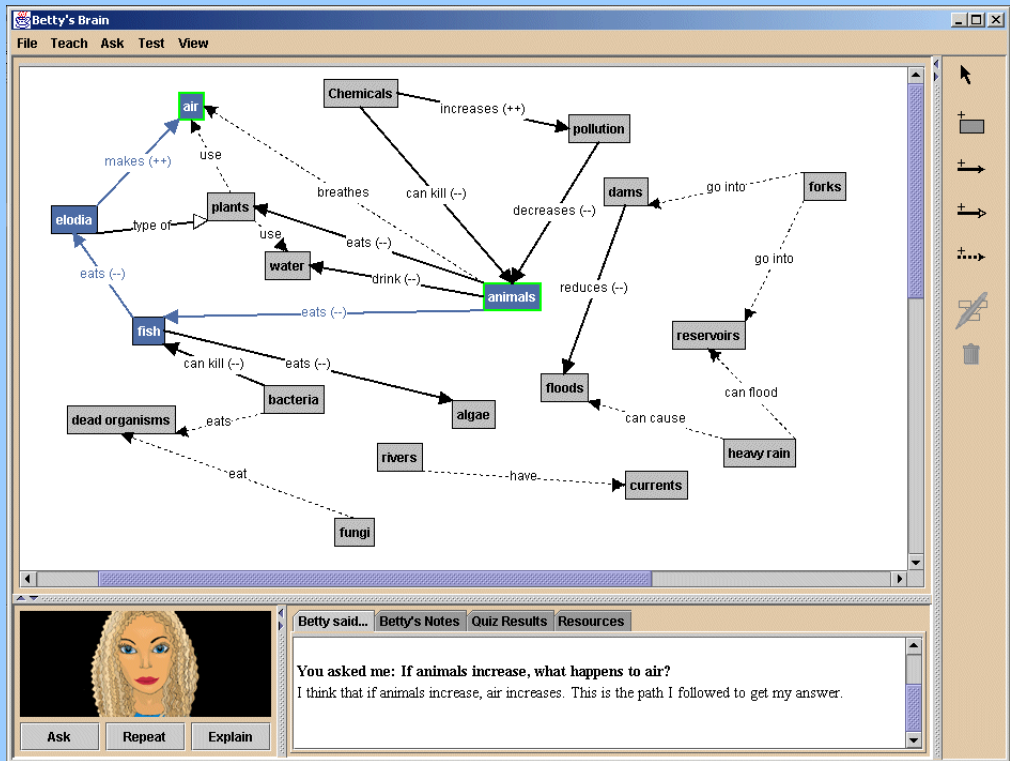

Images

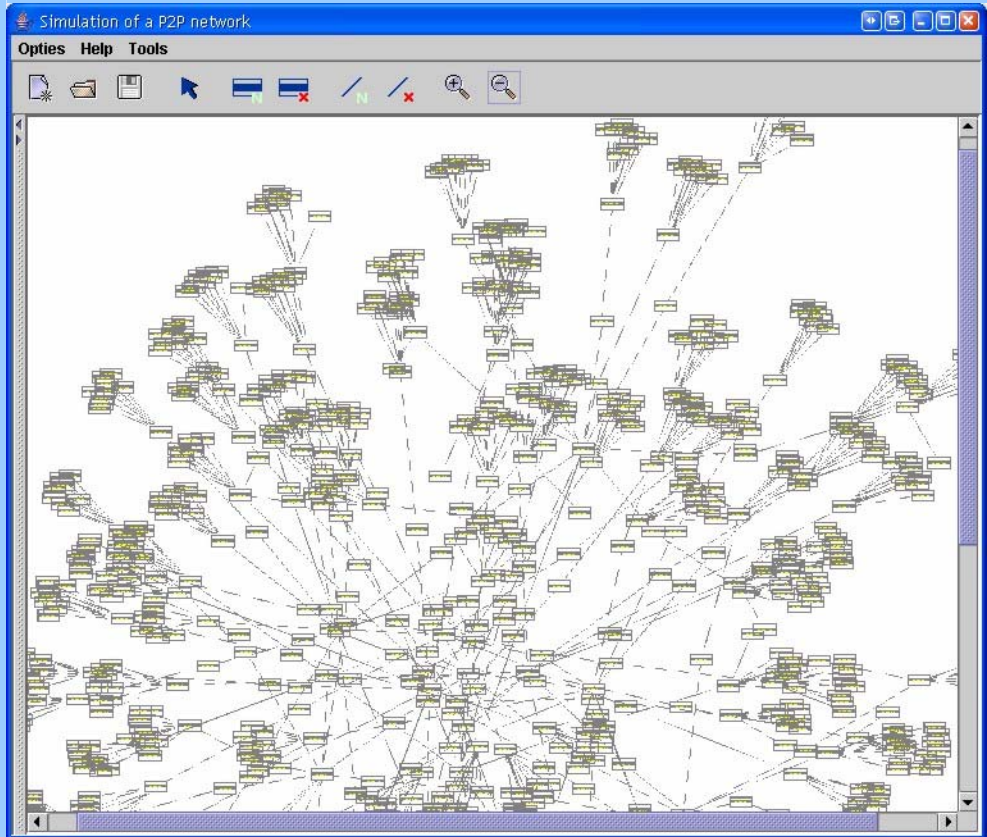

Last Modified	2006-12-15 20:17:13
----------------------	---------------------

Name	JGraphT
URL	http://jgrapht.sourceforge.net/
Description	<p>Brief description: JGraphT is a free Java graph library that provides mathematical graph-theory objects and algorithms.</p> <p>Detailed description: JGraphT and JGraph are two different libraries optimized for different purposes. JGraphT: <ul style="list-style-type: none"> - is optimized for data models and algorithms. - is designed to support high-performance and large-scale applications. - can handle graphs with a few millions vertices and edges. - provides visualizations by using JGraph </p>
Product Version/Status	0.7.0 (2006-07-03)

Context

<u>Main Functionalities</u>	<ul style="list-style-type: none"> • Automated Layout • Graph Viewing • Network Analysis 	Comments:
<u>Domain</u>	<ul style="list-style-type: none"> • Any 	Comments:

Network Representation

<u>Type</u>	<ul style="list-style-type: none"> • Directed • Undirected 	
<u>Links</u>	<ul style="list-style-type: none"> • Labelled • User Defined • Weighted 	Comments:
<u>Dimensionality</u>	<ul style="list-style-type: none"> • 2D 	Comments:

Analysis

<u>Network Analysis</u>	<ul style="list-style-type: none"> • Connection:Connectivity • Connection:Cycle • Connection:Shortest Path 	Comments:
--------------------------------	---	------------------

Deployment

	<p><u>Type:</u></p> <ul style="list-style-type: none"> • Components for tool building • Open Source - GPL 	<p><u>OS:</u></p> <ul style="list-style-type: none"> • Multi-Platform (JAVA)
--	--	--

<u>OS Comments/Dependencies</u>	JDK 1.4 is required at a minimum. To take full advantage of JGraphT generics (starting with version 0.7.0), use JDK 1.5 or higher.	
<u>Extensibility</u>	<ul style="list-style-type: none"> JAVA 	Comments:
<u>Interoperability</u>		
<u>Scalability</u>	Max Nodes: Unlimited Max Links: Unlimited	Comments:
	<u>Hardware:</u>	<u>Users:</u> <u>Availability:</u> <ul style="list-style-type: none"> Freeware In Development
<u>Cost</u>	Free	Comments: Released under the GNU Lesser General Public License. http://jgraph.sourceforge.net/LGPL.html
Last Modified	2006-12-15 20:13:44	

Name	JUNG	
URL	http://jung.sourceforge.net/	
Description	Brief description: A JAVA based API for graph visualization and analysis. Detailed description: JUNG is a Java-based open-source software library designed to support the modeling, analysis, and visualization of data that can be represented as graphs. Its focus is on mathematical and algorithmic graph applications pertaining to the fields of social network analysis, information visualization, knowledge discovery and data mining. However, it is not specific to these fields and can be used for many other applications pertaining to graphs and networks.	
<u>Product Version/Status</u>	1.7.5 (20 October 2006) There is active development and it appears to be updated regularly.	
Context		
<u>Main Functionalities</u>	<ul style="list-style-type: none"> Automated Layout Graph Manipulation Graph Viewing Network Analysis 	Comments:
<u>Domain</u>	<ul style="list-style-type: none"> Any 	Comments:

Network Representation

<u>Links</u>	<ul style="list-style-type: none"> • User Defined 	Comments: Any JAVA data type can be used for link/node attributes
<u>Nodes</u>	<ul style="list-style-type: none"> • User Defined 	
<u>Layout Algorithms</u>	<ul style="list-style-type: none"> • Circular • Clustered • Random • Self-Organizing Map (Meyer) • Spring • Spring FR • Spring KK • Tree 	Comments:
<u>Dimensionality</u>	<ul style="list-style-type: none"> • 2D 	Comments:

Analysis

<u>General Analysis</u>	<ul style="list-style-type: none"> • Data Transformation:Direction 	Comments:
<u>Network Analysis</u>	<ul style="list-style-type: none"> • Centrality • Centrality:Degree • Centrality:HITS • Centrality:PageRank • Centrality:Random-walk • Betweenness • Cluster Recognition • Connection:Max. Flow • Connection:Shortest Path • k-Neighbor • Subgraph:Triad Census 	Comments:

User Interaction

<u>User Interaction</u>	<ul style="list-style-type: none"> • Add/Delete • Drag & Drop • Draw • GUI • Pan • Reposition • Zoom 	<p>Comments: JUNG supports dynamic graphs that can be changed both through a system of filters or by explicitly adding and removing nodes. Either way, it's easy to visualize the results, to apply graph algorithms to the results, and to manipulate those results further.</p> <p>Jung provides numerous functions for handling mouse inputs as well as providing some higher level user interactions (e.g. pan, zoom, etc.)</p>
-------------------------	---	--

Deployment

	<p>Type:</p> <ul style="list-style-type: none"> • Components for tool building • Open Source 	<p>OS:</p> <ul style="list-style-type: none"> • Multi-Platform (JAVA)
--	---	---

<u>OS Comments/ Dependencies</u>	JDK 1.4 Apache Jakarta Commons Collections 3.1 Cern Colt Scientific Library 1.2.0 Xerces for GraphML reading and writing							
<u>Extensibility</u>	<ul style="list-style-type: none"> • JAVA 	Comments: Since JUNG is an open source framework for graph generation and visualization, users can add virtually any functionality that they may require.						
<u>Interoperability</u>	<p>Pajek file format - JUNG can currently interpret the portions of the Pajek format that define directed, undirected, and mixed-type graphs; string (text) labels for vertices; and numeric edge weights. The format can also represent time-series and labeled vertex partition information, but JUNG does not as yet interpret these parts of the format.</p> <p>GraphML - JUNG can currently interpret the portions of this format that define directed, undirected, and mixed-type graphs, and simple vertex and edge decorations. JUNG does not currently interpret the hypergraph and nested graph portions of the format.</p> <p>Since JUNG is open source, developers could write a parser for a desired file format.</p>							
<u>Scalability</u>	Max Nodes: Unlimited Max Links: Unlimited	Comments:						
	<table border="0" style="width: 100%;"> <tr> <td style="width: 33%;"><u>Hardware:</u></td> <td style="width: 33%;"><u>Users:</u></td> <td style="width: 33%;"><u>Availability:</u></td> </tr> <tr> <td></td> <td></td> <td> <ul style="list-style-type: none"> • Freeware • In Development • In Use </td> </tr> </table>		<u>Hardware:</u>	<u>Users:</u>	<u>Availability:</u>			<ul style="list-style-type: none"> • Freeware • In Development • In Use
<u>Hardware:</u>	<u>Users:</u>	<u>Availability:</u>						
		<ul style="list-style-type: none"> • Freeware • In Development • In Use 						
<u>Cost</u>	Free	Comments: Released under the BSD license						

Images

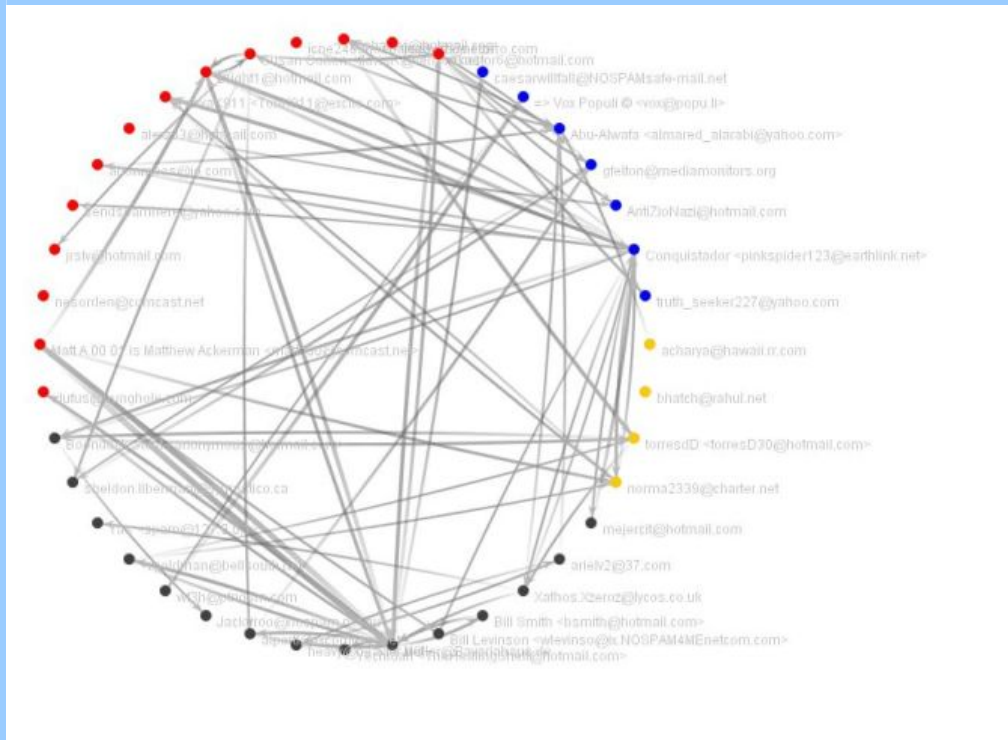
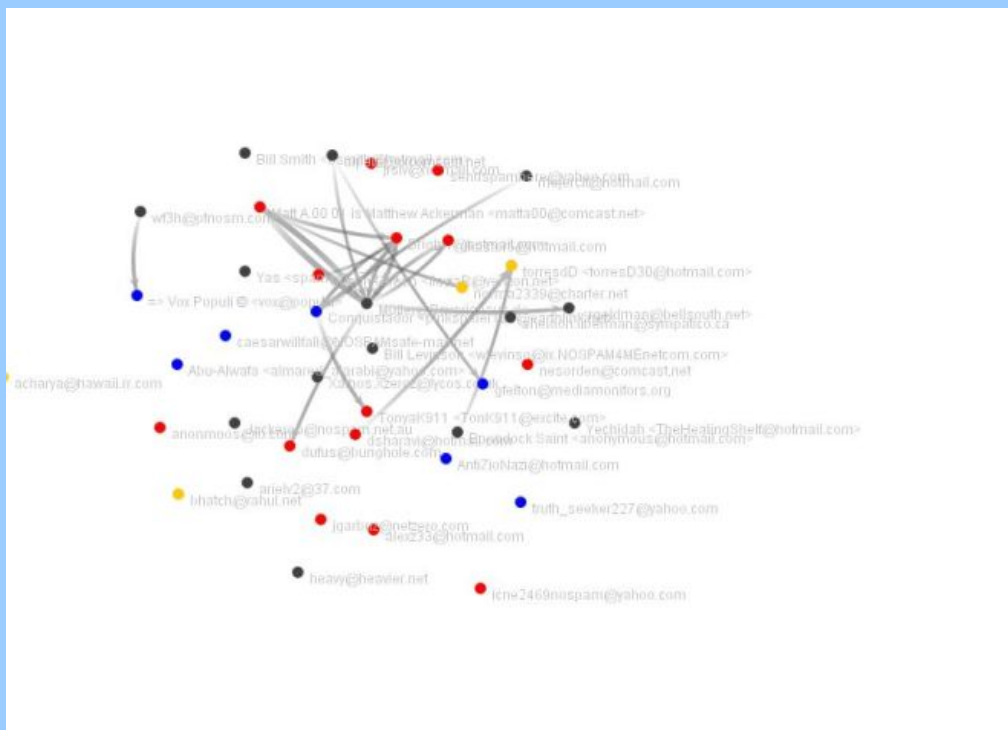

References

API documentation
<http://jung.sourceforge.net/doc/api/index.html>

Projects using JUNG
<http://jung.sourceforge.net/pmwiki/index.php/Main/ProjectsUsingJUNG>

Last Modified

2006-12-18 19:49:10

Name	Kliquefinder	
URL	http://www.msu.edu/~kenfrank/software.htm#KliqueFinder_	
Description	<p>Brief description: Kliquefinder is based on a general algorithm for identifying cliques (clusters or subgroups) of actors in network data.</p> <p>Detailed description: It identifies non-overlapping cohesive subgroups in social network data. It maps ties within and between cohesive subgroups.</p>	
Context		
Domain	<ul style="list-style-type: none"> • Social Networks 	Comments:
Analysis		
General Analysis	<ul style="list-style-type: none"> • Statistics:Correlation • Statistics:Frequency • Statistics:Matrix QAP 	Comments:
Network Analysis	<ul style="list-style-type: none"> • Centrality • Centrality:Betweenness • Centrality:Closeness • Centrality:Coreness • Centrality:Degree • Centrality:Edge Betweenness • Centrality:Effects • Centrality:Eigenvector • Centrality:Flow Betweenness • Centrality:Graph • Centrality:HITS • Centrality:Information • Centrality:Link Betweenness • Centrality:Load • Centrality:Node Betweenness • Centrality:PageRank • Centrality:Power • Centrality:Random-walk Betweenness • Connection:Link Connectivity • Connection:Max. Flow • Connection:Min. Cutset • Connection:Node Connectivity • Connection:Path • Connection:Shortest Path 	Comments:
Deployment		
	<p>Type:</p> <ul style="list-style-type: none"> • Components for tool building 	<p>OS:</p> <ul style="list-style-type: none"> • UNIX • Windows

Interoperability	Plots graphs and exports to .eps files.
Last Modified	2006-12-10 16:39:16

Name	KrackPlot
URL	http://www.isi.edu/~blythe/KP/
Description	<p>Brief description: KrackPlot is a network visualization tool intended for social network</p> <p>Detailed description:</p>
Product Version/Status	Version 4.1, revision 7, built on 2/22/2006

Context		
----------------	--	--

Main Functionalities	<ul style="list-style-type: none"> Automated Layout Graph Viewing 	Comments:
Domain	<ul style="list-style-type: none"> Social Networks 	Comments:

Network Representation		
-------------------------------	--	--

Dimensionality	<ul style="list-style-type: none"> 2D 	Comments:
--------------------------------	--	------------------

Deployment		
-------------------	--	--

	<p>Type:</p> <ul style="list-style-type: none"> Standalone Tool 	<p>OS:</p> <ul style="list-style-type: none"> Multi-Platform (JAVA)
Cost	Free	Comments:

--	--	--

Last Modified	2006-12-10 16:39:16
----------------------	---------------------

Name	LANsurveyor
URL	http://www.neon.com/LSwin.shtml
Description	<p>Brief description: LAN Surveyor diagrams and monitors computer networks</p> <p>Detailed description: LANsurveyor draws network maps by manually entering data or it will discover / draw the network by using ICMP (ping), NetBIOS, or SNMP. Also performs layer 2 mapping and IDS scanning.</p>

Product Version/Status	LANsurveyor 9.6	
Context		
Main Functionalities	<ul style="list-style-type: none"> Automated Layout Graph Viewing Network Analysis Network management/discovery 	Comments:
Domain	<ul style="list-style-type: none"> Computer Networks 	Comments:
	User Role:	Activity: <ul style="list-style-type: none"> Monitor
Network Representation		
Dimensionality	<ul style="list-style-type: none"> 2D 	Comments:
User Interaction		
User Interaction	<ul style="list-style-type: none"> Add/Delete Cut & Paste GUI Pan Scroll Undo/Redo Zoom 	Comments:
Deployment		
	Type: <ul style="list-style-type: none"> Standalone Tool 	OS: <ul style="list-style-type: none"> Linux Mac OS X Windows Windows 2000 Windows 2003 Windows 95/98/ME Windows NT Windows XP
OS Comments/Dependencies	Mac OS X version 10.1.5 Mac OS 8 or 9 Linux - 2.4+ kernel	
Interoperability	Maps can be exported to Viso 2002 or greater and to enhanced metafile (EMF) format	
	Hardware:	Users: <ul style="list-style-type: none"> Availability: <ul style="list-style-type: none"> Commercially Available

Cost	\$101 - \$1000	Comments: IDS - \$6000
-------------	----------------	----------------------------------



Images

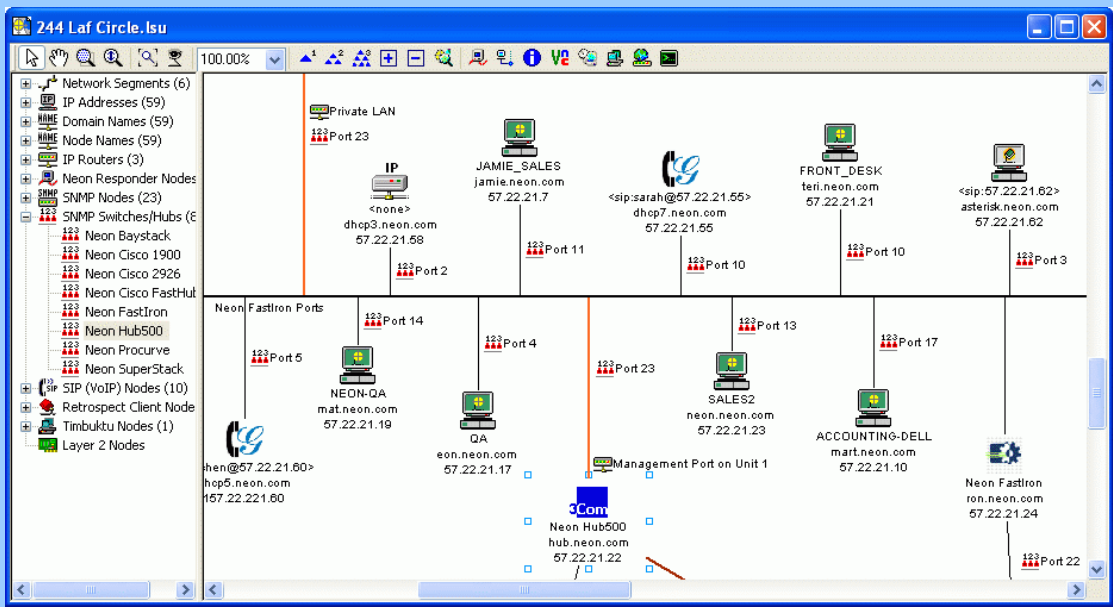
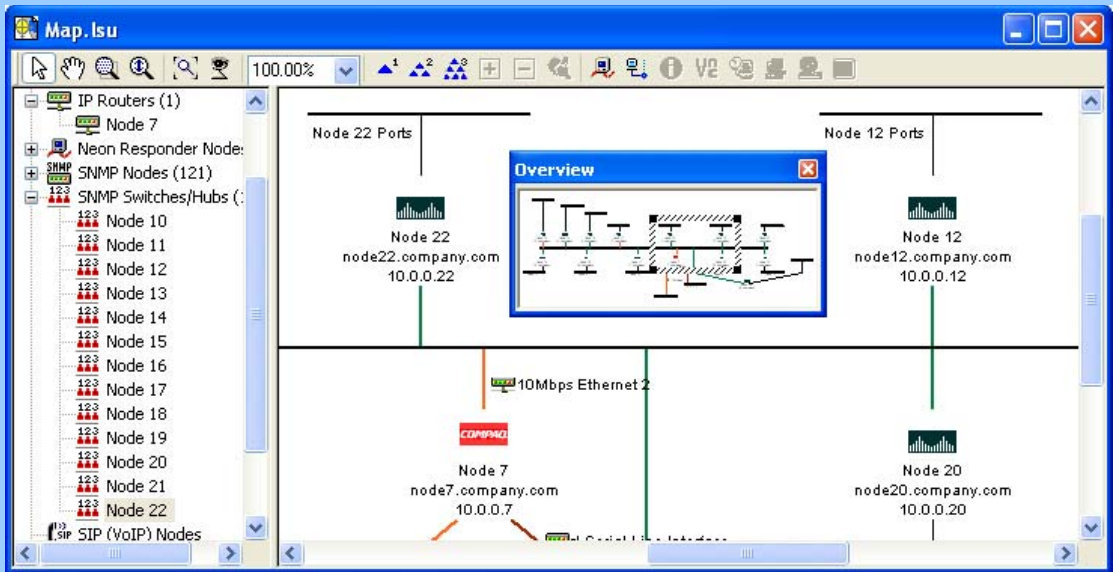

Last Modified	2006-12-16 17:37:33
----------------------	---------------------

Name	Large Graph Layout
URL	http://apropos.icmb.utexas.edu/lgl/
Description	Brief description: LGL is a compendium of applications for making the visualization of large networks and trees tractable. LGL was specifically motivated by the need to make the

	visualization and exploration of large biological networks more accessible. Detailed description:	
Product Version/Status	1.1 (2005-08-31 23:43)	
Context		
Main Functionalities	<ul style="list-style-type: none"> Automated Layout Graph Viewing 	Comments: Iglview is a JAVA application written solely for viewing 2D graphs generated by LGL
Domain	<ul style="list-style-type: none"> Any 	Comments:
Network Representation		
Nodes	<ul style="list-style-type: none"> Labelled 	Comments:
Dimensionality	<ul style="list-style-type: none"> 2D 3D 	Comments:
User Interaction		
User Interaction	<ul style="list-style-type: none"> Command Line 	Comments:
Deployment		
	Type: <ul style="list-style-type: none"> Open Source - GPL Standalone Tool 	OS: <ul style="list-style-type: none"> Linux Mac OS X Windows
OS Comments/Dependencies	The programs will only compile on Linux systems with gnu compilers. Iglview will work for windows ONLY UNDER JAVA VERSION 1.4.1_07.	
Interoperability	A VRML file can be generated for 3D graphs.	
Scalability	Max Nodes: Unlimited Max Links: Unlimited	Comments:
	Hardware:	Users: <ul style="list-style-type: none"> Single
		Availability: <ul style="list-style-type: none"> Freeware Research Prototype
Cost	Free	Comments:

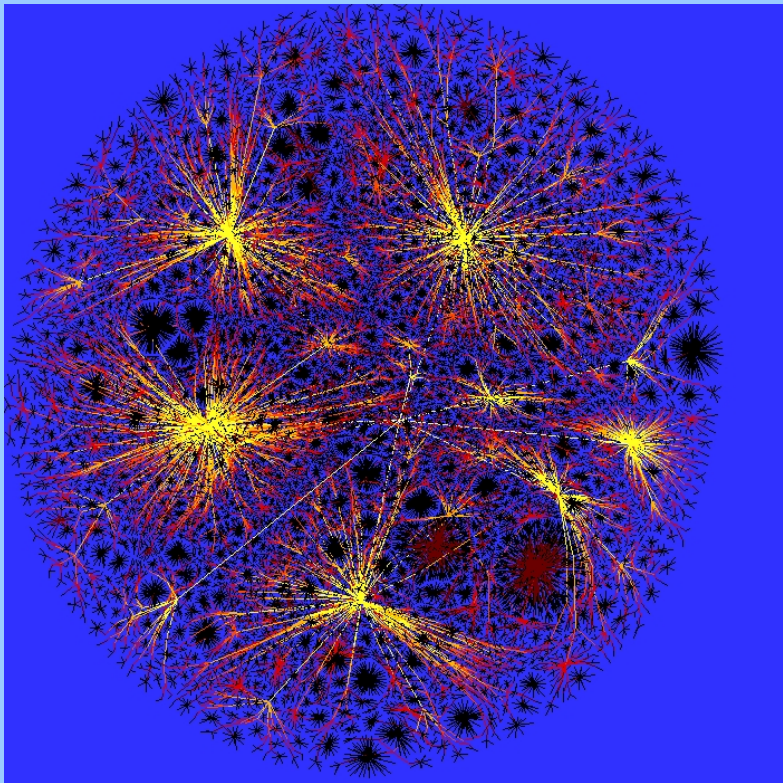
Images	
Last Modified	2006-12-10 16:39:16

Name	LEDA	
URL	http://algorithmic-solutions.com/enledapakete.htm	
Description	<p>Brief description: C++ class library for efficient data types and algorithms.</p> <p>Detailed description: It provides algorithmic knowledge in the field of graph- and network problems, geometric computations, combinatorial optimization and others. It provides algorithm building blocks dealing with objects such as graphs, sequences, dictionaries, trees, points, flows, matchings, segments, shortest paths, and more.</p>	
Product Version/Status	LEDA 5.1. Current Support.	
Context		
Main Functionalities	<ul style="list-style-type: none"> • Network Analysis 	<p>Comments: LEDA is used in application areas such as telecommunication, GIS, VLSI design, scheduling, traffic planning, computational biology and computer-aided design.</p>
Domain	<ul style="list-style-type: none"> • Any 	Comments:

Network Representation

<u>Type</u>	<ul style="list-style-type: none"> Directed Undirected 	
<u>Links</u>	<ul style="list-style-type: none"> User Defined 	Comments: Container data types: list, array, map, dictionary, priority queue, stack, queue, set, dynamic tree. Basic data types: searching and sorting algorithms. Any JAVA data type can be used for link/node attributes
<u>Nodes</u>	<ul style="list-style-type: none"> User Defined 	
<u>Dimensionality</u>	<ul style="list-style-type: none"> 2D 3D 	Comments:

Analysis

<u>Network Analysis</u>	<ul style="list-style-type: none"> Centrality:Graph Connection:All Pairs Shortest Path Connection:Connectivity Connection:Distance Connection:Flow Connection:Node Connectivity Connection:Path Connection:Shortest Path Graph Structure Traversal:Breadth First Search 	Comments: A wide variety of graph and network algorithms like depth-first search, breadth-first search, shortest paths, minimal spanning trees, matching, weighted matching ,network flow, planarity testing, graph layout and many more.
-------------------------	---	---

Deployment

	<u>Type:</u> <ul style="list-style-type: none"> Components for tool building 	<u>OS:</u> <ul style="list-style-type: none"> Linux UNIX Windows
<u>Extensibility</u>	<ul style="list-style-type: none"> C++ 	Comments:
	<u>Hardware:</u>	<u>Users:</u>
		<u>Availability:</u>
<u>Cost</u>	\$1001 - \$5000	Comments: Server license: \$8000 Source Code: \$20,000

Last Modified

Last Modified	2006-12-10 16:39:16
----------------------	---------------------

Name	LibSea
-------------	---------------

URL	http://www.caida.org/tools/visualization/libsea/	
Description	<p>Brief description: LibSea is both a file format and a Java library for representing large directed graphs.</p> <p>Detailed description: The LibSea file format allows one to specify the topology of directed graphs using nodes, links, and paths (paths are sequences of links; to attach data to nodes, links, and paths in a flexible manner; and to implement application-specific conventions and semantics.</p>	
Product Version/Status	LibSea 0.1 - supported. LibSea Java library requires JDK 1.2 or later	
Context		
Main Functionalities	<ul style="list-style-type: none"> Automated Layout Graph Viewing 	Comments:
Domain	<ul style="list-style-type: none"> Any 	Comments:
Network Representation		
Type	<ul style="list-style-type: none"> Directed 	
Links	<ul style="list-style-type: none"> User Defined 	Comments: Data types: boolean, integer, float, double, string, triples of floats ('float3'), triples of doubles ('double3'), and user-defined enumerations.
Nodes	<ul style="list-style-type: none"> User Defined 	
Dimensionality	<ul style="list-style-type: none"> 2D 	Comments:
Deployment		
	<p>Type:</p> <ul style="list-style-type: none"> Components for tool building Open Source 	<p>OS:</p> <ul style="list-style-type: none"> Multi-Platform (JAVA)
Interoperability	API	
Scalability	Max Nodes: Unlimited Max Links: Unlimited	Comments:
	Hardware:	Users: Availability: <ul style="list-style-type: none"> Freeware
Cost	Free	Comments: released under the GNU Lesser GPL http://www.gnu.org/copyleft/lesser.html

Last Modified	2006-12-15 20:30:45

Name	Link Analyst
URL	http://www.networkinstruments.co.uk/products/analyst.html
Description	<p>Brief description: Graphically monitor the status of your network.</p> <p>Detailed description: With Link Analyst you can:</p> <ul style="list-style-type: none"> • Reduce Troubleshooting Time • Detect Network Abnormalities, and Device and Route Failures • Configure Alarms for Instant Notification Alerts via Program, Pager, or Email • Quickly Create Maps of Even the Largest Networks Locally or Remotely • Log Response Times with Historical Logging Function • View Historical Data and Current Map Status From Any Web Browser • Graphically Arrange Display for Easy and Quick Viewing • Complement Other Diagnostic/Troubleshooting Solutions • Easy to Install and Use

Context

<u>Main Functionalities</u>	<ul style="list-style-type: none"> • Automated Layout • Graph Manipulation • Graph Viewing • Network managment/discovery 	Comments:
<u>Domain</u>	<ul style="list-style-type: none"> • Computer Networks 	Comments:
	<p><u>User Role:</u></p>	<p><u>Activity:</u></p> <ul style="list-style-type: none"> • Monitor

Network Representation

<u>Links</u>	<ul style="list-style-type: none"> • Labelled 	Comments:
<u>Nodes</u>	<ul style="list-style-type: none"> • Labelled • Symbol 	
<u>Layout Algorithms</u>	<ul style="list-style-type: none"> • Bus • Circular 	Comments:
<u>Dimensionality</u>	<ul style="list-style-type: none"> • 2D 	Comments:

User Interaction

<u>User Interaction</u>	<ul style="list-style-type: none"> • Add/Delete • Cut & Paste • Drag & Drop 	Comments:
--------------------------------	--	------------------

	<ul style="list-style-type: none"> • Draw • Drill down • GUI • Reposition 	
--	---	--

Deployment

	<p><u>Type:</u></p> <ul style="list-style-type: none"> • Standalone Tool 	<p><u>OS:</u></p> <ul style="list-style-type: none"> • Windows • Windows 2000 • Windows 95/98/ME • Windows NT
--	---	---

	<p><u>Hardware:</u></p>	<p><u>Users:</u></p>	<p><u>Availability:</u></p> <ul style="list-style-type: none"> • Commercially Available
--	-------------------------	----------------------	--

<u>Cost</u>	\$101 - \$1000	<u>Comments:</u>
-------------	----------------	------------------

Images

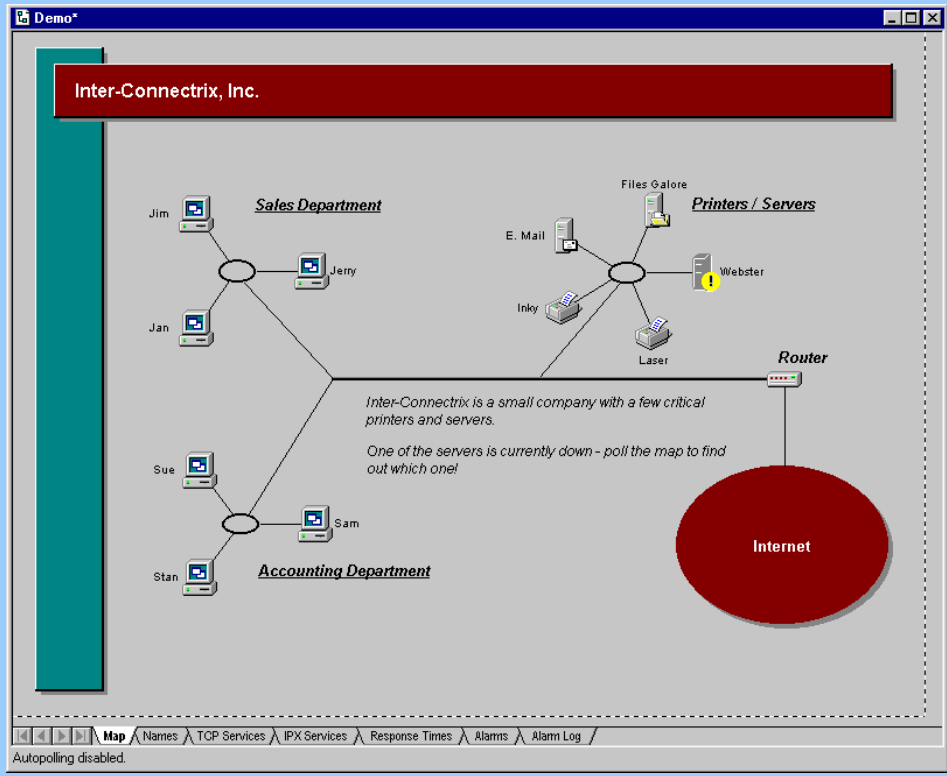

Last Modified	2006-12-16 17:37:48
----------------------	---------------------

Name	LinLogLayout
URL	http://www.informatik.tu-cottbus.de/~an/GD/

Description	<p>Brief description: a simple, easy-to-use open source program (written in Java) for computing graph drawings, using the LinLog energy models and standard energy models like Fruchterman-Reingold.</p> <p>Detailed description:</p>
--------------------	---

Network Representation

<u>Links</u>		Comments:
<u>Nodes</u>	<ul style="list-style-type: none"> • Labelled 	
<u>Layout Algorithms</u>	<ul style="list-style-type: none"> • Force-Directed • Spring • Spring FR • Spring:LinLog 	Comments:
<u>Dimensionality</u>	<ul style="list-style-type: none"> • 3D 	Comments:

Deployment

	<p><u>Type:</u></p> <ul style="list-style-type: none"> • Open Source - GPL 	<p><u>OS:</u></p> <ul style="list-style-type: none"> • Multi-Platform (JAVA)
<u>Extensibility</u>	<ul style="list-style-type: none"> • JAVA 	Comments:
	<p><u>Hardware:</u></p>	<p><u>Users:</u></p> <ul style="list-style-type: none"> • Single <p><u>Availability:</u></p> <ul style="list-style-type: none"> • Freeware • Research Prototype
<u>Cost</u>	Free	Comments:

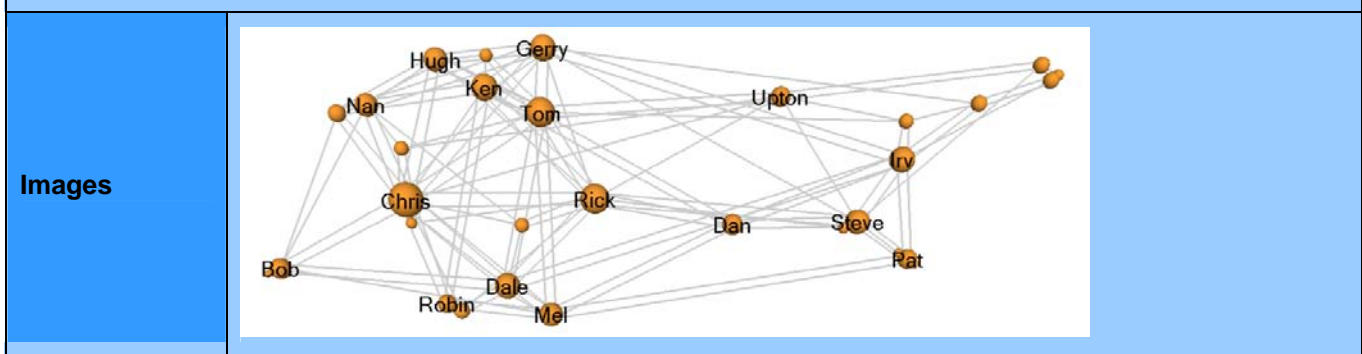

Last Modified	2006-12-10 16:39:16
----------------------	---------------------

Name	LoriotPro
URL	http://www.loriotpro.com/
Description	Brief description:

	<p>LoriotPro is a network management suite providing network discovery, topology mapping, and monitoring.</p> <p>Detailed description: Feature overview:</p> <p>Monitor availability and performance of any type of IP connected hardware and software, workstation, printer, routers, switches, servers, UPS, OS, applications.</p> <p>Display the current availability status through visual and graphical representation.</p> <p>Discover, manage and classify connected hardware and software resources. Perform inventory and reporting.</p> <p>Performance and load measurement, rendered in real time graph, trend graph, counter and gauge graph.</p>
--	--

Context

<u>Main Functionalities</u>	<ul style="list-style-type: none"> Automated Layout Graph Manipulation Graph Viewing Network management/discovery 	Comments:
<u>Domain</u>	<ul style="list-style-type: none"> Computer Networks 	Comments:
	<p><u>User Role:</u></p>	<p><u>Activity:</u></p> <ul style="list-style-type: none"> Monitor Track

Network Representation

<u>Links</u>	<ul style="list-style-type: none"> User Defined 	Comments: Active Views allows you to link dynamic information to objects (nodes, links). For instance, the background colour of a dynamic object can be linked to the availability status of a host.
<u>Nodes</u>	<ul style="list-style-type: none"> Symbol User Defined 	
<u>Layout Algorithms</u>		Comments: LoriotPro allows you to add a context to any network layout through its active views. The background of a network can be anything from a floorplan to a geographic map.
<u>Dimensionality</u>	<ul style="list-style-type: none"> 2D Geospatial 	Comments:

Analysis

<u>General Analysis</u>	<ul style="list-style-type: none"> Trend Analysis 	Comments:
<u>Visual Abstraction</u>	<ul style="list-style-type: none"> Chart:Line 	Comments: Network Interface Monitor graphs:

		<p>Incoming/Outgoing for interface index ... Interface load in % Packets in Error Packets Discarded</p> <p>Trend View - Multi Router Traffic Grapher (MRTG) Front End : You can graph almost all OID (SNMP object ID) objects like Network interface traffics, CPU usage, disk usage, printer queue usage, E-mail queue usage, WEB traffic etc...</p> <p>Linear Graph: The Linear Graph displays two SNMP object value (Y axis) on a time period (X axis).</p>
--	--	---

User Interaction

<u>User Interaction</u>	<ul style="list-style-type: none"> • Add/Delete • Cut & Paste • Drag & Drop • Draw • GUI • Pan • Reposition • Resize • Scroll • Select • Undo/Redo • Web/CGI 	Comments:
-------------------------	--	------------------

Deployment

	<p><u>Type:</u></p> <ul style="list-style-type: none"> • Standalone Tool 	<p><u>OS:</u></p> <ul style="list-style-type: none"> • Windows 2000 • Windows XP
--	---	--

<u>OS Comments/Dependencies</u>	Windows XP PRO
---------------------------------	----------------

<u>Interoperability</u>	Web interface via web browser (HTML, JAVA)
-------------------------	--

	<p><u>Hardware:</u></p>	<p><u>Users:</u></p> <ul style="list-style-type: none"> • Multiple • Networked 	<p><u>Availability:</u></p> <ul style="list-style-type: none"> • Commercially Available
--	-------------------------	--	--

<u>Cost</u>	\$1001 - \$5000	<p>Comments:</p> <p>Lite edition: 500 euros Standard edition: 1500 euros Extended edition: 4500 euros</p>
-------------	-----------------	--

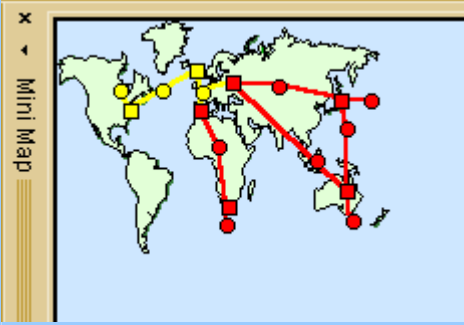
Images	
Last Modified	2006-12-16 17:38:08

Name	Mapnet	
URL	http://www.caida.org/tools/visualization/mapnet/	
Description	<p>Brief description: Mapnet is a tool for visualizing the infrastructure of multiple international backbone providers simultaneously.</p> <p>Detailed description: Each backbone infrastructure is divided into a group of nodes (POPs) and pipes between these nodes, drawing them based on their geographical location on a map of the world.</p>	
Product Version/Status	Not currently maintained.	
Context		
Main Functionalities	<ul style="list-style-type: none"> Automated Layout Graph Viewing 	Comments:
Domain	<ul style="list-style-type: none"> Computer Networks 	Comments:
Network Representation		
Links	<ul style="list-style-type: none"> Labelled 	Comments:
Nodes	<ul style="list-style-type: none"> Labelled 	
Dimensionality	<ul style="list-style-type: none"> 2D Geospatial 	Comments:
Deployment		
	<p>Type:</p> <ul style="list-style-type: none"> Open Source Web-based 	<p>OS:</p> <ul style="list-style-type: none"> Multi-Platform (JAVA)
Cost	Free	Comments:

Images

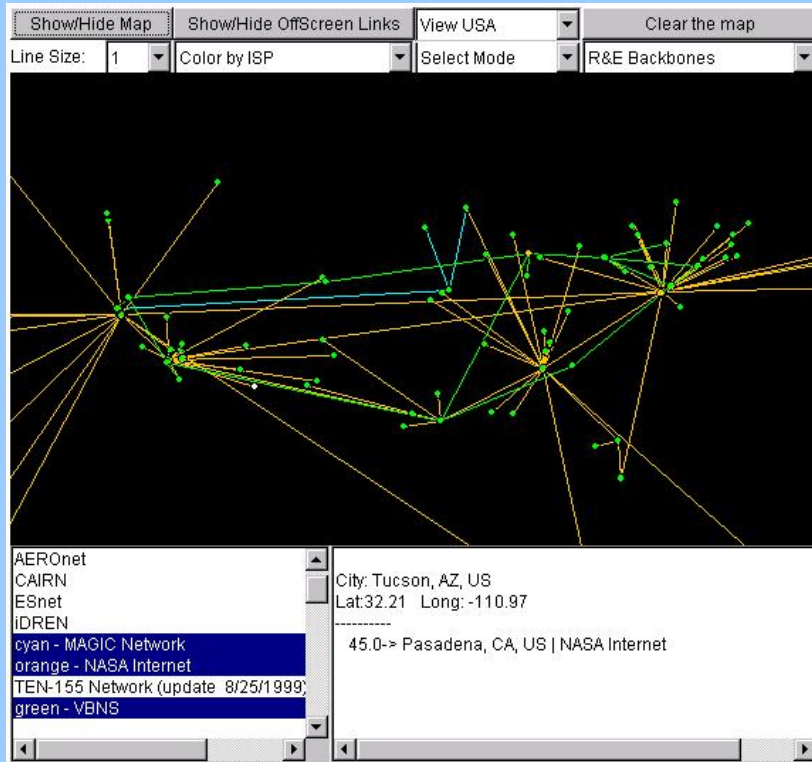
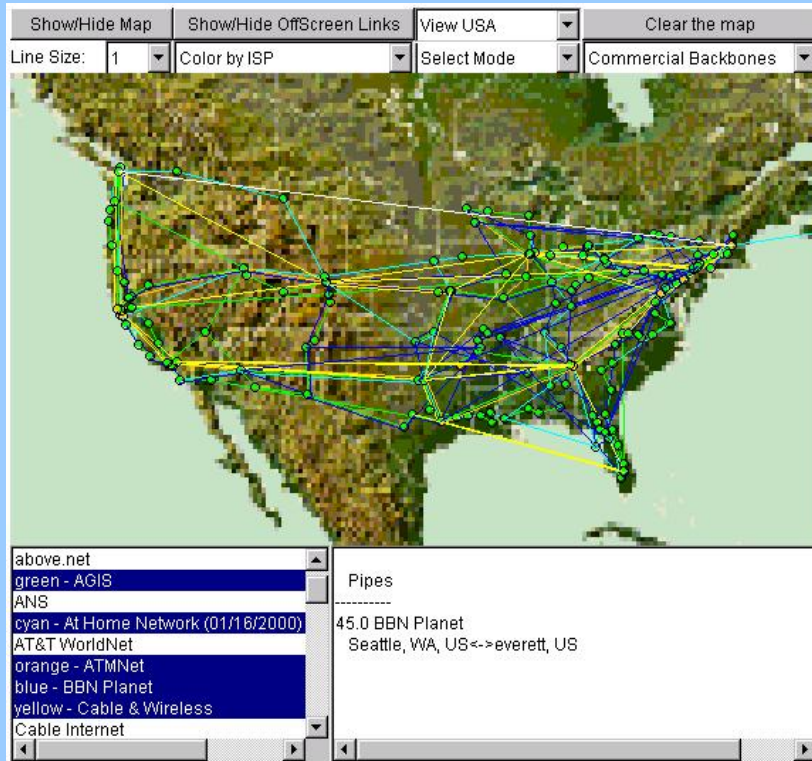

Last Modified

2006-12-10 16:39:16

Name	Mathematica	
URL	http://www.wolfram.com/products/mathematica/introduction.html	
Description	<p>Brief description: Mathematica is a computer algebra system. Among its vast computation features are functions for large graph drawing.</p> <p>Detailed description:</p>	
Product Version/Status	5.2 (July 12, 2005)	
Context		
Main Functionalities	<ul style="list-style-type: none"> Automated Layout Computer Algebra System Graph Viewing 	Comments:
Domain	<ul style="list-style-type: none"> Any 	Comments:
Network Representation		
Type	<ul style="list-style-type: none"> Directed Undirected 	
Links	<ul style="list-style-type: none"> Coloured 	Comments:
Nodes	<ul style="list-style-type: none"> Coloured 	
Layout Algorithms	<ul style="list-style-type: none"> Force-Directed High-dimensional embedding Radial Tree Spring Tree 	Comments:
Dimensionality	<ul style="list-style-type: none"> 2D 3D 	Comments:
Visual Enhancements		
Visual Enhancements	<ul style="list-style-type: none"> Animation/Video 	Comments:
User Interaction		
User Interaction	<ul style="list-style-type: none"> Command Line 	Comments:
Deployment		
	<p>Type:</p> <ul style="list-style-type: none"> Standalone Tool 	<p>OS:</p> <ul style="list-style-type: none"> HP-UX IRIX

		<ul style="list-style-type: none"> • Linux • Mac OS X • Multi-Platform • Solaris • UNIX • Windows • Windows 2000 • Windows 2003 • Windows 95/98/ME • Windows NT • Windows XP
<u>Extensibility</u>	<ul style="list-style-type: none"> • .NET • C • C# • C++ • JAVA • Visual Basic 	Comments: Mathematica includes a custom scripting language.
<u>Interoperability</u>	Mathlink is an interface that allows external programs to access the Mathematica kernel. A C/C++ MathLink Software Developer Kit (SDK) ships with every version of Mathematica J/Link and .NET/Link are toolkits that integrate Java or the Microsoft .NET Framework with Mathematica. They let you call code written in Java or any .NET compatible language from Mathematica in a completely transparent way, and it lets you use and control the Mathematica kernel from Java or .NET programs.	
<u>Scalability</u>	Max Nodes: Unlimited Max Links: Unlimited	Comments:
	<u>Hardware:</u>	<u>Users:</u>
		<u>Availability:</u> <ul style="list-style-type: none"> • Commercially Available
<u>Cost</u>	\$1001 - \$5000	Comments: Windows, Linux and MacOS: \$1,880 UNIX: \$3,135

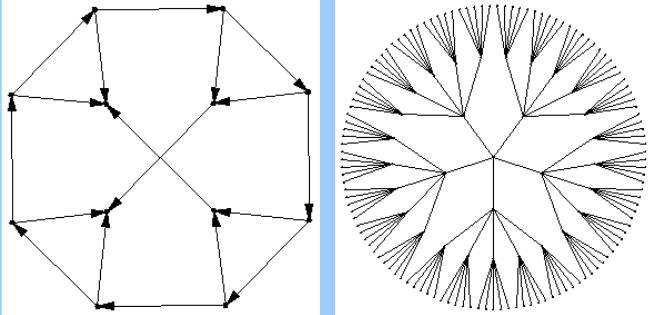
Images	
References	GraphPlot documentation http://documents.wolfram.com/mathematica/functions/AdvancedDocumentationGraphPlot
Last Modified	2006-12-10 16:39:16

Name	MatrixExplorer	
Description	<p>Brief description: A social network visualization system that uses both node-link diagrams and matrices.</p> <p>Detailed description: From Abstract: MatrixExplorer is a network visualization system that uses two representations: node-link diagrams and matrices. Its design comes from a list of requirements formalized after several interviews and a participatory design session conducted with social science researchers. Although matrices are commonly used in social networks analysis, very few systems support the matrix-based representations to visualize and analyze networks. MatrixExplorer provides several novel features to support the exploration of social networks with a matrix-based representation, in addition to the standard interactive filtering and clustering functions. It provides tools to reorder (layout) matrices, to annotate and compare findings across different layouts and find consensus among several clusterings. MatrixExplorer also supports Node-link diagram views which are familiar to most users and remain a convenient way to publish or communicate exploration results. Matrix and node-link representations are kept synchronized at all stages of the exploration process.</p>	
Context		
Main Functionalities	<ul style="list-style-type: none"> Automated Layout Graph Manipulation Graph Viewing 	Comments:
Domain	<ul style="list-style-type: none"> Social Networks 	Comments:
Network Representation		
Links		Comments:
Nodes	<ul style="list-style-type: none"> Coloured 	Comments:
Layout Algorithms	<ul style="list-style-type: none"> Clustered 	Comments:

Analysis		
Network Analysis	<ul style="list-style-type: none"> Cluster Recognition 	Comments:
User Interaction		
User Interaction	<ul style="list-style-type: none"> Drag & Drop GUI Pan 	Comments:
Deployment		
	<u>Type:</u> <ul style="list-style-type: none"> Standalone Tool 	<u>OS:</u>
	<u>Hardware:</u>	<u>Users:</u>
		<u>Availability:</u> <ul style="list-style-type: none"> Research Prototype
References		
References	See paper: Henry-InfoVis2006.pdf - "MatrixExplorer: a Dual-Representation System to Explore Social Networks"	
Last Modified	2006-12-17 18:44:14	

Name	MERL	
URL	http://dt.cs.arizona.edu/	
Description	<p>Brief description: An Interactive Multi-User System for Simultaneous Graph Drawing</p> <p>Detailed description: From Abstract In this paper we consider the problem of simultaneous drawing of two graphs. The goal is to produce aesthetically pleasing drawings for the two graphs by means of a heuristic algorithm and with human assistance. Our implementation uses the DiamondTouch table, a multi- user, touch-sensitive input device, to take advantage of direct physical interaction of several users working collaboratively</p>	
Context		
Main Functionalities	<ul style="list-style-type: none"> Automated Layout Graph Manipulation Graph Viewing 	Comments:
Domain	<ul style="list-style-type: none"> Any 	Comments:
Network Representation		

Links	<ul style="list-style-type: none"> • Coloured 	Comments:
Nodes	<ul style="list-style-type: none"> • Coloured • Labelled 	
Dimensionality	<ul style="list-style-type: none"> • 2D 	Comments:

User Interaction

User Interaction	<ul style="list-style-type: none"> • Add/Delete • Drag & Drop • GUI • Reposition • Sensory:Touch 	Comments: The system uses the DiamondTouch table, a multi- user, touch-sensitive input device.
----------------------------------	---	--

Deployment

	Type:	OS:	<ul style="list-style-type: none"> • Multi-Platform (JAVA)
	Hardware:	Users:	Availability:
	<ul style="list-style-type: none"> • Electronic Whiteboard with Click and Drag 	<ul style="list-style-type: none"> • Multiple 	<ul style="list-style-type: none"> • Research Prototype

Images

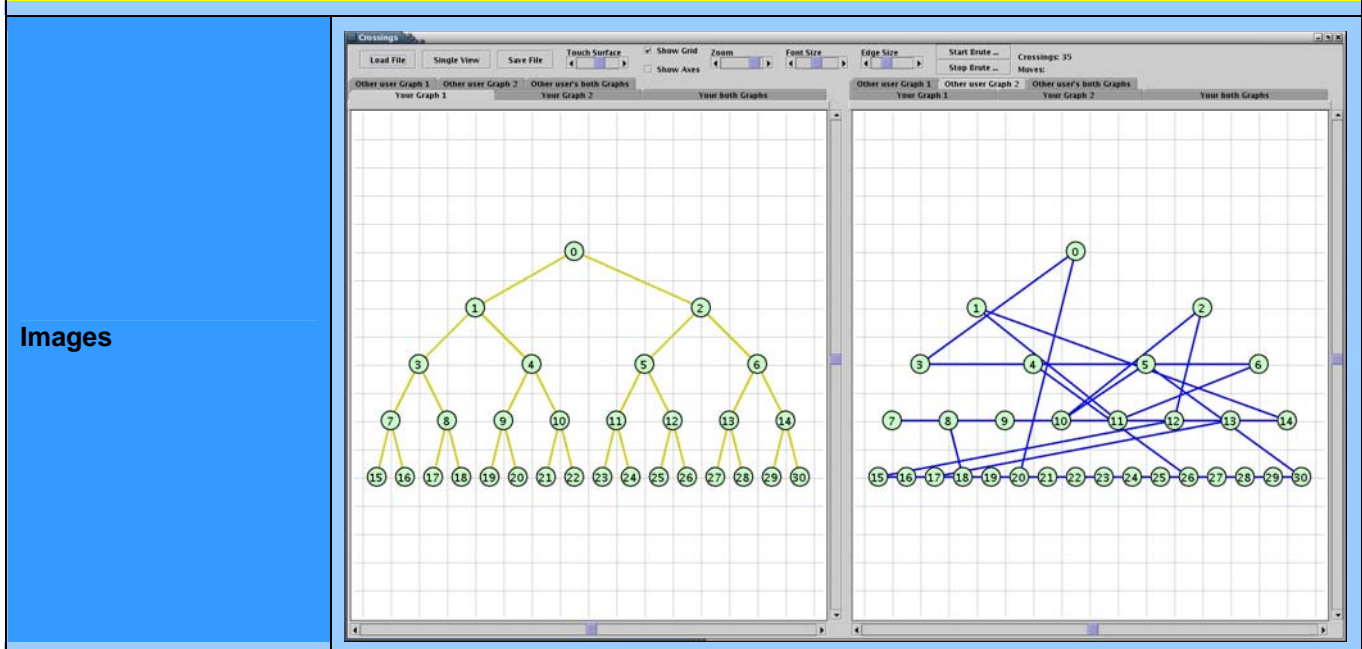

Last Modified	2006-12-18 19:12:50
----------------------	---------------------

Name	Monarch Graph
-------------	----------------------

URL	http://www.singleton-labs.com/mgraph.php	
Description	<p>Brief description: MonarchGraph is a framework for visualizing graph data structures under Java 2 environment.</p> <p>Detailed description:</p>	
Context		
Main Functionalities	<ul style="list-style-type: none"> Automated Layout Graph Manipulation Graph Viewing 	Comments:
Domain	<ul style="list-style-type: none"> Any 	Comments:
Network Representation		
Links	<ul style="list-style-type: none"> User Defined 	Comments: Extensible set of node visual representations and link types.
Nodes	<ul style="list-style-type: none"> User Defined 	
Layout Algorithms	<ul style="list-style-type: none"> Hierarchical Tree 	Comments: Extensible architecture allows users to create custom layout algorithms.
Dimensionality	<ul style="list-style-type: none"> 2D 	Comments:
User Interaction		
User Interaction	<ul style="list-style-type: none"> Add/Delete Drag & Drop GUI Layers Zoom 	Comments: All user interactions with the diagram are handled by plug-in classes. Plug-ins may process mouse and keyboard events and also get a chance to paint on to of the graph view.
Deployment		
	<p>Type:</p> <ul style="list-style-type: none"> Components for tool building 	<p>OS:</p> <ul style="list-style-type: none"> Multi-Platform (JAVA)
Extensibility	<ul style="list-style-type: none"> JAVA 	Comments: Plugin interface.
Interoperability	Import/Export SVG GIF, JPEG and PNG image output.	
	Hardware:	<p>Users:</p> <p>Availability:</p> <ul style="list-style-type: none"> Commercially Available
Cost	\$101 - \$1000	Comments: Single developer license - \$199.00 Redistribution license - \$499.00

		Source code license - \$1799.00 Site license - \$1790.00
--	--	---



Images

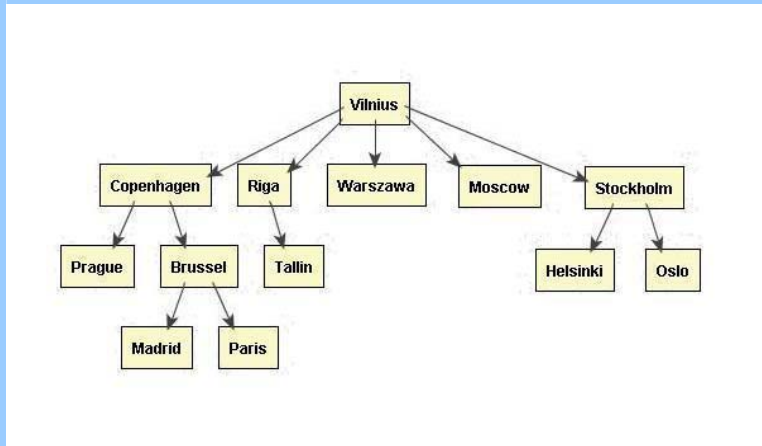
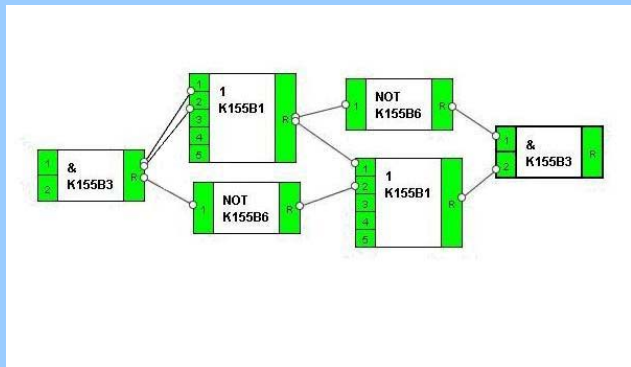

References	API ref. http://www.singleton-labs.com/manual/doc/index.html
-------------------	---

Last Modified	2006-12-18 19:13:13
----------------------	---------------------

Name	Nagios
URL	http://www.nagios.org/
Description	<p>Brief description: Nagios is an open source host, service and network monitoring program</p> <p>Detailed description: Nagios is a host and service monitor designed to inform you of network problems before your clients, end-users or managers do. It has been designed to run under the Linux operating system, but works fine under most *NIX variants as well. The monitoring daemon runs intermittent checks on hosts and services you specify using external "plugins" which return status information to Nagios. When problems are encountered, the daemon can send notifications out to administrative contacts in a variety of different ways (email, instant message, SMS, etc.). Current status information, historical logs, and reports can all be accessed via a web browser.</p>

	Features: 1) Monitoring of network services (via SMTP, POP3, HTTP, PING, etc). 2) A plugin interface to allow for user-developed service monitoring methods. 3) Notifications when problems occur and get resolved (via email, pager, or user-defined method). 4) Ability to define "event handlers" for proactive problem resolution 5) Web output (current status, notifications, problem history, log file, etc.) 6) Automatic log file rotation/archiving	
Product Version/Status	2.5 as of 06/10/28 (released 06/07/13)	
Context		
Main Functionalities	<ul style="list-style-type: none"> Automated Layout Network management/discovery 	Comments:
Domain	<ul style="list-style-type: none"> Computer Networks 	Comments:
	User Role:	Activity: <ul style="list-style-type: none"> Investigate Monitor Track
Network Representation		
Dimensionality	<ul style="list-style-type: none"> 2D 3D 	Comments:
User Interaction		
User Interaction	<ul style="list-style-type: none"> GUI Web/CGI 	Comments:
Deployment		
	Type: <ul style="list-style-type: none"> Open Source - GPL Standalone Tool 	OS:
Extensibility	<ul style="list-style-type: none"> C CGI 	Comments: Nagios supports plugins. Plugins can be compiled executables or scripts (Perl, shell, etc.) that can be run from a command line. Nagios uses the results from plugins to determine the current status or hosts and services on your network.
	Hardware:	Users: <ul style="list-style-type: none"> Multiple Networked
		Availability: <ul style="list-style-type: none"> Freeware

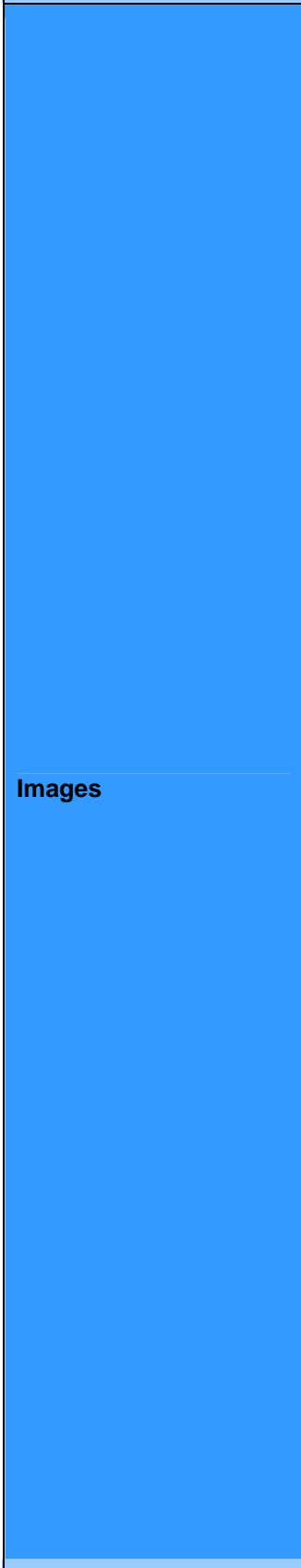

Images

Nagios - Netscape

File Edit View Go Communicator Help

Back Forward Reload Home Search Netscape Print Security Shop Stop

Bookmarks Go to: What's Related

Nagios™

General

- Home
- Documentation

Monitoring

- Tactical Overview
- Service Detail
- Host Detail
- Status Overview
- Status Summary
- Status Grid
- Status Map
- 3-D Status Map
- Service Problems
- Host Problems
- Network Outages
- Comments
- Downtime
- Process Info
- Performance Info
- Scheduling Queue

Reporting

- Trends
- Availability
- Histogram
- Alert History
- Notifications
- Event Log

Configuration

- View Config

Network Map For All Hosts

Last Updated: Sun Jan 6 20:28:54 CST 2002
Updated every 75 seconds

Nagios™ www.nagios.org
Logged in as guest
- Monitoring process is running
- Notifications cannot be sent out!
- Service checks are being executed

[View Status Detail For All Hosts](#)
[View Status Overview For All Hosts](#)

Layout Method: Circular (Marked Up) Scaling factor: 0.7

Drawing Layers:
Windows Workstations
Nagios Servers
Linux Servers
Mail Servers

Layer mode:
 Include
 Exclude

Suppress popups:

Update

Nagios - Netscape

File Edit View Go Communicator Help

Back Forward Reload Home Search Netscape Print Security Shop Stop

Bookmarks Go to: What's Related

Nagios

General

- Home
- Documentation

Monitoring

- Tactical Overview
- Status Detail
- Status Overview
- Status Summary
- Status Grid
- Status Map
- 3-D Status Map
- Service Problems
- Network Outages
- Trends
- Availability
- Alert History
- Notifications
- Log File
- Comments
- Process Info
- Performance Info

Configuration

- View Config

Last Modified	2006-12-18 19:13:31
----------------------	---------------------

Name	Nam: Network Animator
URL	http://www.isi.edu/nsnam/nam/
Description	<p>Brief description: Nam is a Tcl/TK based animation tool for viewing network simulation traces and real world packet traces.</p> <p>Detailed description: Network animator (nam) is a tool for animating packet trace data. This trace data is typically derived from network simulators (e.g. ns or from real network measurements (e.g. tcpdump)</p>
Product Version/Status	1.11 released 05/02/03

Context

Main Functionalities	<ul style="list-style-type: none"> Automated Layout Graph Viewing 	Comments:
Domain	<ul style="list-style-type: none"> Computer Networks 	Comments:

Network Representation

Layout Algorithms	<ul style="list-style-type: none"> Spring 	Comments:
--------------------------	--	------------------

Deployment

	<p>Type:</p> <ul style="list-style-type: none"> Open Source Standalone Tool 	<p>OS:</p> <ul style="list-style-type: none"> Linux UNIX Windows
Extensibility	<ul style="list-style-type: none"> C++ Tcl/Tk 	Comments:

Deployment

Last Modified	2006-12-10 16:39:16
----------------------	---------------------

Name	Net-Probe
URL	http://www.net-probe.com/
Description	<p>Brief description: Net-Probe assists network administrators by provide up-to-date information about the status of the network</p> <p>Detailed description:</p>

	<p>Features</p> <p>Real Time Monitoring: Net-Probe offers real time monitoring of any network connected device. It does this through a rich graphical interface available through a web browser as well as a dedicated application. Items can be monitored in two ways, either graphed or as an alarm.</p> <p>Graphical layout: Alarms and graphs are integrated into the graphical layout. Drawing elements have been kept as simple as possible enabling for simple, quick and neat representations of the monitored environment to be setup.</p> <p>Network layout Detection: Wizards allow for any network to be scanned and a representation of it drawn in a few easy steps. This shows the interconnection of each device.</p> <p>Alarms: Alarms check a host or service. Below are the methods of acquiring data. You are not limited to these (see expandability below). * SNMP * Performance Monitor * Scripts</p> <p>Actions: Actions are performed when an alarm goes off. These could be notification type alerts, either graphical or sound. They could also be functions like sending an email, restarting a service etc.</p> <p>Alerter: The Alerter is a small application that lives in your task bar and will inform you of the status of the items being monitored.</p> <p>Graphs: Real time graphs can be included in the layout. The graphs are highly customizable. Like most systems in Net-Probe wizards guide you through the creation process.</p> <p>Network Tools: A number of tools have been included. These include ping, traceroute, snmp browser, dns and a network scanner.</p> <p>Expandability: One of the methods of getting data for the alarms and graphs are scripts. Dozens of prewritten scripts have been included to measure and test most standard networked services. The source of these is open allowing you to expand or specialize them to other tasks. This makes it possible to monitor any network device. Scripts can also be added to perform specialized actions when an alarm goes off.</p>	
<p>Product Version/Status</p>	<p>2.1.0</p>	
<p>Context</p>		
<p>Main Functionalities</p>	<ul style="list-style-type: none"> • Graph Manipulation • Graph Viewing • Network managment/discovery 	<p>Comments:</p>

<u>Domain</u>	<ul style="list-style-type: none"> • Computer Networks 	Comments:
	<u>User Role:</u>	<u>Activity:</u> <ul style="list-style-type: none"> • Monitor • Track
Network Representation		
<u>Links</u>	<ul style="list-style-type: none"> • Coloured • Pre-Defined Attributes (see comments) 	Comments: Device Attributes: -FQDN, IP and Mask -Note -SNMP Community -Picture -Colors (Fill and Border) -Draw Dash -Shape Network Connection / Line Attributes: -IP and Mask -Line Width -Line Color
<u>Nodes</u>	<ul style="list-style-type: none"> • Pre-Defined Attributes (see comments) • Symbol 	
<u>Layout Algorithms</u>		Comments: Wizards allow for any network to be scanned and a representation of it drawn in a few easy steps. The representation can include interface graphs and system/network alarms.
<u>Dimensionality</u>	<ul style="list-style-type: none"> • 2D • Geospatial 	Comments:
Analysis		
<u>Visual Abstraction</u>	<ul style="list-style-type: none"> • Chart:Area • Chart:Line 	Comments:
User Interaction		
<u>User Interaction</u>	<ul style="list-style-type: none"> • GUI • Web/CGI 	Comments: Web interface is optional
Deployment		
	<u>Type:</u> <ul style="list-style-type: none"> • Standalone Tool 	<u>OS:</u> <ul style="list-style-type: none"> • Windows • Windows 2000 • Windows 2003 • Windows XP
<u>Extensibility</u>	<ul style="list-style-type: none"> • Perl • VBS 	Comments: User customizable scripts are one of the method Net-Probe uses for gathering data about the network. These scripts can be modified making it possible to

		monitor any network device. Also, scripts can be created to perform specialized actions when an alarm is triggered.
	<p>Hardware:</p> <p>Users:</p> <p>Availability:</p> <ul style="list-style-type: none"> • Commercially Available • Shareware 	
Cost	\$101 - \$1000	<p>Comments:</p> <p>A fully functional program can be downloaded free of charge. It will function without restriction for 30 days. After this period a license will need to be purchased to continue using the program.</p> <p>A license for Net-Probe costs \$295</p>



Images

Last Modified	2006-12-18 19:13:51
----------------------	---------------------

Name	NetCool Precision for IP Networks
-------------	--

URL	http://www.micromuse.com/	
Description	<p>Brief description: NetCool Precision for IP Networks automatically discovers layer 2 and layer 3 devices and creates network topology maps. The topology map is dynamically updated to reflect changes in the physical network.</p> <p>Detailed description:</p>	
Context		
Main Functionalities	<ul style="list-style-type: none"> Automated Layout Graph Manipulation Graph Viewing Network management/discovery 	Comments:
Domain	<ul style="list-style-type: none"> Computer Networks 	Comments:
	User Role:	Activity: <ul style="list-style-type: none"> Monitor
Deployment		
	Type: <ul style="list-style-type: none"> Standalone Tool 	OS:
Extensibility	<ul style="list-style-type: none"> JAVA Perl 	Comments: API provided
Interoperability	Data export to Oracle, Sybase and Remedy databases (via DIST adapter).	
	Hardware:	Users:
		Availability: <ul style="list-style-type: none"> Commercially Available
Last Modified		
	2006-12-16 17:39:26	

Name	NetCrunch
URL	http://www.adremsoft.com/netcrunch/
Description	<p>Brief description: Adrem's NetCrunch is a network management solution feature advanced presentation of network topology.</p> <p>Detailed description: Netcrunch provides network management features such as: Network visualization - Instantly discover your network; map servers, devices and</p>

	<p>services and their dependencies; create custom views of your infrastructure.</p> <p>Server Monitoring - Track the health and performance of Windows, NetWare, Linux or any SNMP-enabled server; be immediately alerted on server issues</p> <p>Network Monitoring - Keep tabs on your multi-vendor network devices such as routers, switches, hubs, WAPs, or printers; be notified of device problems.</p> <p>Application Monitoring - Constantly watch the health of your mission-critical applications: MS SQL, MS Exchange, MS IIS, Active Directory.</p> <p>Event Management - Control and consolidate network events with event log, syslogs, SNMP traps, notifications and automated response system.</p> <p>Trending/Reporting - Plan network capacity with multi-chart performance views, trend viewing tool and customizable, web-enabled reports.</p>	
Product Version/Status	4.1 as of 06/10/28	
Context		
Main Functionalities	<ul style="list-style-type: none"> Automated Layout Network management/discovery 	Comments:
Domain	<ul style="list-style-type: none"> Computer Networks 	Comments:
	User Role:	Activity: <ul style="list-style-type: none"> Monitor Track
Network Representation		
Links		Comments:
Nodes	<ul style="list-style-type: none"> Labelled Symbol 	
Layout Algorithms		Comments: Typically, the program scans network assets using SNMP and ICMP protocols; however, for a more accurate picture of the network, it can also use Active Directory, Windows Workgroups, and eDirectory.
Dimensionality	<ul style="list-style-type: none"> 2D Geospatial 	Comments:
Analysis		
General Analysis	<ul style="list-style-type: none"> Trend Analysis 	Comments:
Network Analysis	<ul style="list-style-type: none"> Traffic Analysis 	Comments:
Visual Abstraction	<ul style="list-style-type: none"> Chart:Line 	Comments:

	<ul style="list-style-type: none"> • Chart:Pie 	Various performance and trend data may be graphed.
User Interaction		
<u>User Interaction</u>	<ul style="list-style-type: none"> • Add/Delete • Cut & Paste • Draw • GUI • Pan • Reposition • Select • Undo/Redo • Zoom 	Comments:
Deployment		
	<u>Type:</u> <ul style="list-style-type: none"> • Standalone Tool 	<u>OS:</u> <ul style="list-style-type: none"> • Windows 2000 • Windows 2003 • Windows XP
<u>OS Comments/ Dependencies</u>	Dependencies: IE 5.5 or later, Firefox, Mozilla or Netscape	
	<u>Hardware:</u>	<u>Users:</u> <div style="border: 1px solid black; padding: 5px; display: inline-block;"> <u>Availability:</u> <ul style="list-style-type: none"> • Commercially Available </div>
<u>Cost</u>	\$1001 - \$5000	Comments: AdRem NetCrunch 4.x Premium: \$3,395 AdRem NetCrunch 4.x Premium XE: \$4,995 AdRem NetCrunch 4.x Web Access License: \$1,595 - \$2,995
		

Images

Filtered by	Severity	Info
10/4/2006 2:57:18 PM	Critical	Service DNS on gate.sf.ca.aacme.com (192.168.21.5) is Down
10/4/2006 2:52:42 PM	Informational	Service LDAP on fserv.sd.ca.aacme.com (192.168.41.7) is Up
10/4/2006 2:52:42 PM	Informational	Service NNWCP TCP on fserv.sd.ca.aacme.com (192.168.41.7) is Up
10/4/2006 2:52:42 PM	Informational	Service NNWCP UDP on fserv.sd.ca.aacme.com (192.168.41.7) is Up
10/4/2006 2:52:42 PM	Informational	Service SNMP on fserv.sd.ca.aacme.com (192.168.41.7) is Up
Total: 200	44	10 146 0

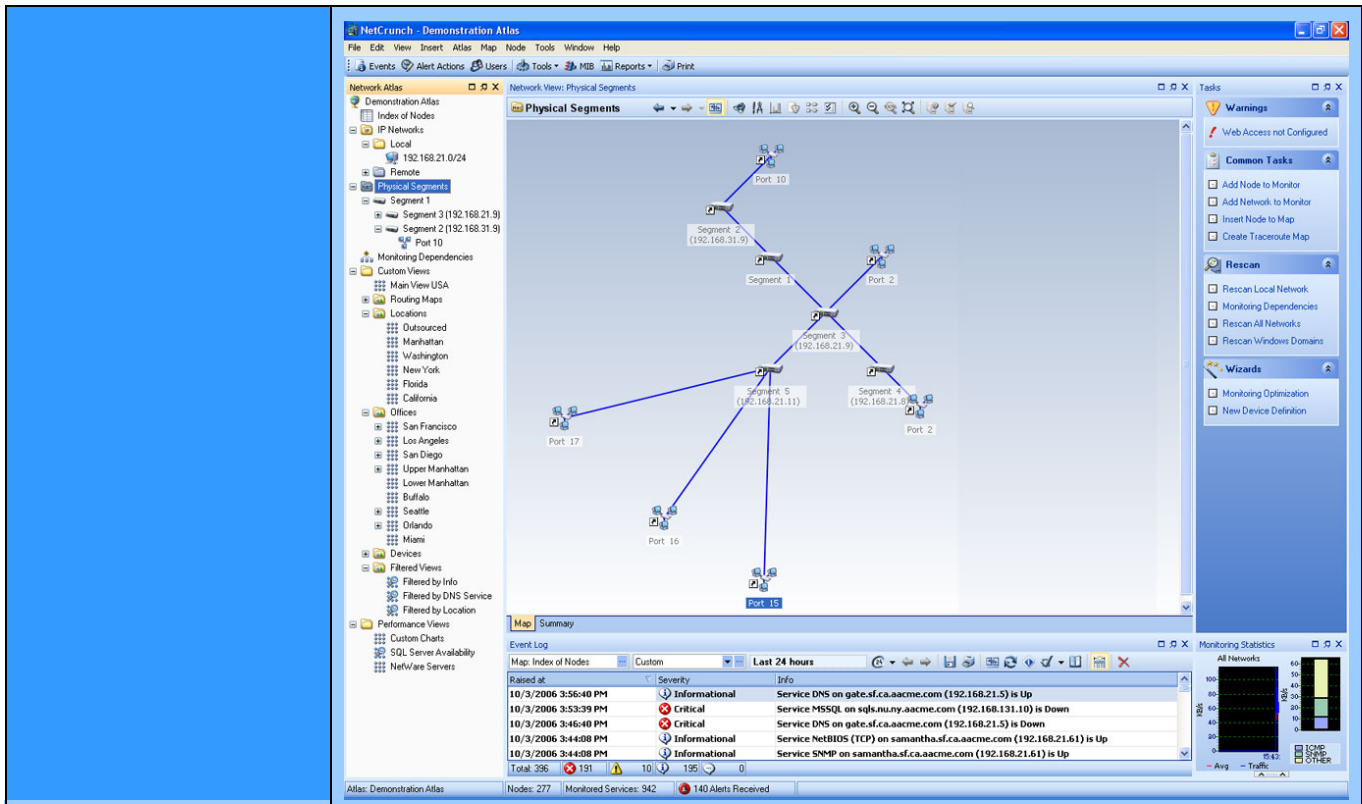

Last Modified	2006-12-18 19:41:15
----------------------	---------------------

Name	Netlayout	
URL	http://www.citi.umich.edu/u/provos/netlayout/	
Description	<p>Brief description: Physics Driven Topology Visualization</p> <p>Detailed description: Netlayout uses a physics models of electrostatic repulsion and spring attraction to find a locally optimal layout for large network topologies. It is possible to animate the optimization process and change relevant parameters for the physics model.</p>	
Product Version/Status	0.1 (2002-11-04)	
Context		
Main Functionalities	<ul style="list-style-type: none"> Automated Layout Graph Viewing 	Comments: Future versions are going to support manual layout direction (according to website).
Domain	<ul style="list-style-type: none"> Any 	Comments:
Network Representation		
Links	<ul style="list-style-type: none"> Coloured 	Comments:

<u>Nodes</u>	<ul style="list-style-type: none"> • Coloured 	
<u>Layout Algorithms</u>	<ul style="list-style-type: none"> • Force-Directed • Spring 	Comments:
<u>Dimensionality</u>	<ul style="list-style-type: none"> • 2D • 3D 	Comments:
Visual Enhancements		
<u>Visual Enhancements</u>	<ul style="list-style-type: none"> • Animation/Video 	Comments:
Deployment		
	<u>Type:</u> <ul style="list-style-type: none"> • Open Source - GPL 	<u>OS:</u> <ul style="list-style-type: none"> • Linux • UNIX
<u>Extensibility</u>	<ul style="list-style-type: none"> • C 	Comments:
<u>Interoperability</u>	Future versions are going to support import and export of network topologies (according to website).	
	<u>Hardware:</u>	<u>Users:</u> <ul style="list-style-type: none"> • Freeware • In Development • Unsupported
<u>Cost</u>	Free	Comments:
		

Images

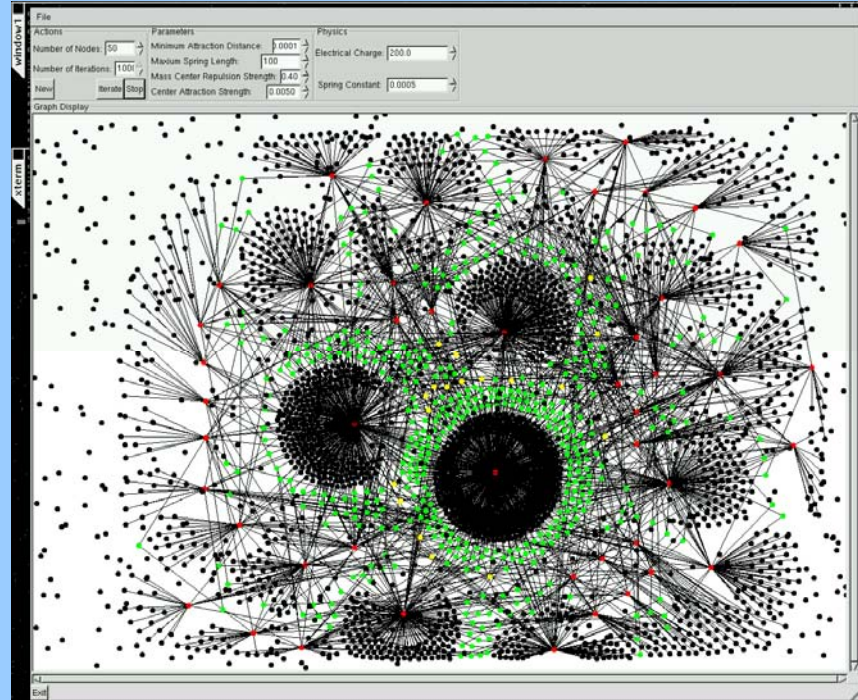
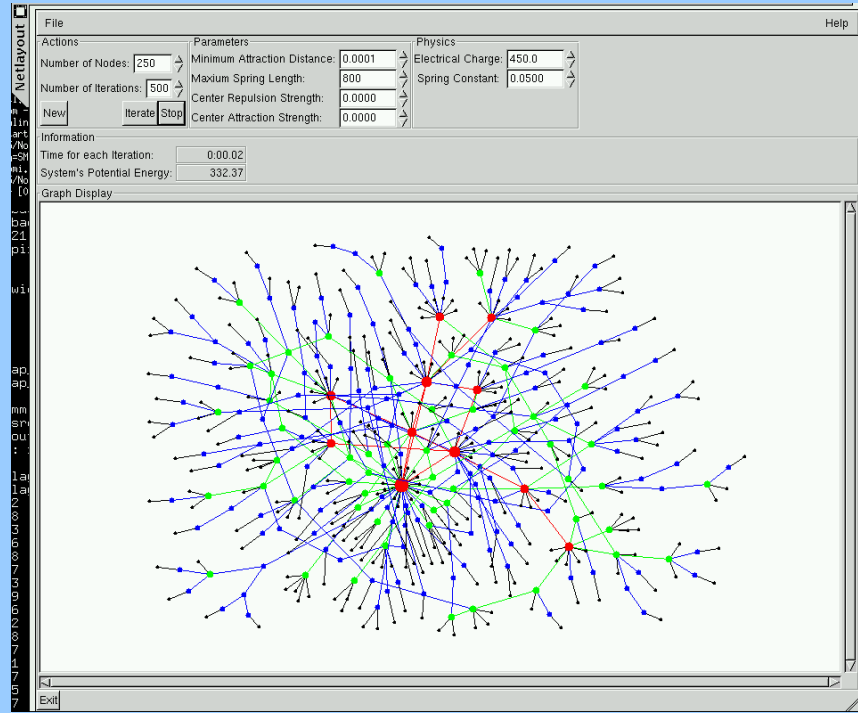

Last Modified

2006-12-10 16:39:16

Name

NetMap

URL

<http://www.netmap.com/>

Description

Brief description:
NetMap finds links and interconnections among seemingly unrelated data.

	Detailed description:	
Product Version/Status	NetMap 6.0.36 Current Support.	
Context		
Main Functionalities	<ul style="list-style-type: none"> Automated Layout Graph Viewing 	Comments: Can be used for diverse applications as relationships and outcomes in a pharmaceutical study, international currency flows, errors in complex billing systems, and fraud in millions of transactions.
Domain	<ul style="list-style-type: none"> Any 	Comments:
Network Representation		
Dimensionality	<ul style="list-style-type: none"> 2D Temporal 	Comments:
User Interaction		
User Interaction	<ul style="list-style-type: none"> GUI Web/CGI 	Comments:
Deployment		
	Type: <ul style="list-style-type: none"> Standalone Tool 	OS: <ul style="list-style-type: none"> Linux Mac OS X UNIX Windows
Extensibility	<ul style="list-style-type: none"> Tcl/Tk 	Comments:
Interoperability	Support for Oracle and SQL databases.	
Scalability	Max Nodes: Unlimited Max Links: Unlimited	Comments:
	Hardware:	Users: <ul style="list-style-type: none"> Multiple Networked
		Availability:
Last Modified		
	2006-12-18 19:14:15	

Name	NetMiner	
URL	http://www.netminer.com/NetMiner/home_01.jsp	
Description	<p>Brief description: NetMiner is a tool for Exploratory Network Data Analysis and Visualization. NetMiner allows you to explore your network data visually and interactively, and helps you to detect underlying patterns and structures of the network</p> <p>Detailed description: Cyrax NetMiner II is an innovative software tool for Exploratory Network Data Analysis and Visualization. Its unique feature lies in the integration of standard social network analysis(SNA) methodology with modern network visualization (or graph drawing) techniques in the spirit of Exploratory Data Analysis(EDA).</p> <p>NetMiner allows you to explore your network data visually and interactively, and helps you to detect underlying patterns and structures of the network.</p> <p>Cyrax NetMiner can be used for general research, teaching and professional analysis in social networks. Also, it can be effectively applied to various business fields, where network-structural factors have great deal of influences on the performance: e.g. intra- and inter-organizational, financial, criminal/intelligence, Web, telecommunication, distribution, transportation networks. Features include:</p> <ul style="list-style-type: none"> • Integration of network analysis and network visualization in one software package • Dynamic linking of network-analytic substance with network map • Incorporates standard and latest set of network analysis tools and data manipulation facilities • Highly interactive user interface which supports quick exploratory data analysis • Generalized data architecture makes it easy to model multi-layered network and inter-connections among relational, affiliation and attribute variables 	
Product Version/Status	2.6.0a (released 05/10/13)	
Context		
Main Functionalities	<ul style="list-style-type: none"> • Automated Layout • Graph Manipulation • Graph Viewing • Network Analysis 	Comments:
Domain	<ul style="list-style-type: none"> • Any • Social Networks 	Comments:
Network Representation		
Links	<ul style="list-style-type: none"> • Coloured • Labelled • User Defined 	Comments: The main nodeset in a dataset can have multiple attribute variables. Attribute variables are used for things such as node colour, but additional attribute variables can be created.
Nodes	<ul style="list-style-type: none"> • Coloured • Labelled • User Defined 	
Layout Algorithms	<ul style="list-style-type: none"> • Circular 	Comments:

	<ul style="list-style-type: none"> • Clustered • Concentric • MDS:Classical (Torgerson-Gower) • MDS:Nonmetric (ALSCAL) • MDS:Nonmetric (Kruskal) • Radial • Spring Ed • Spring FR • Spring KK 	2D/3D Layouts: Spring KK, Spring Ed, Clustered, MDS classical, and MDS (ALSCAL)
<u>Dimensionality</u>	<ul style="list-style-type: none"> • 2D • 3D 	Comments:

Analysis

<u>General Analysis</u>	<ul style="list-style-type: none"> • Data Transformation:Direction • Data Transformation:Link Set • Data Transformation:Mode • Data Transformation:Node Set • Data Transformation:Proximity • Data Transformation:Relations • Data Transformation:Weight • Statistics:ANOVA • Statistics:Autocorrelation • Statistics:Cluster • Statistics:Correlation • Statistics:Correspondence • Statistics:Covariance Matrix • Statistics:Crosstabs • Statistics:Decomposition • Statistics:Descriptives • Statistics:Factor Analysis • Statistics:Frequency • Statistics:Gini Coefficient • Statistics:MDS • Statistics:Principal Component • Statistics:Regression 	Comments:
-------------------------	---	------------------

<u>Network Analysis</u>	<ul style="list-style-type: none"> • 2-Mode:Col. Filtering • 2-Mode:Eigenvector Centrality • 2-Mode:Max. Matching • Centrality:Closeness • Centrality:Coreness • Centrality:Degree • Centrality:Effects • Centrality:Eigenvector • Centrality:Flow Betweenness • Centrality:HITS • Centrality:Information • Centrality:Link Betweenness • Centrality:Load • Centrality:Node Betweenness 	Comments:
-------------------------	---	------------------

	<ul style="list-style-type: none"> • Centrality:PageRank • Centrality:Power • Centrality:Random-walk Betweenness • Centrality:Status • Cohesion:Bi-Component • Cohesion:Clique • Cohesion:Cohesive Block • Cohesion:Community(Fast) • Cohesion:Community(GN) • Cohesion:Component • Cohesion:k-Core • Cohesion:k-Plex • Cohesion:Lambda Set • Cohesion:n-Clan • Cohesion:n-Clique • Cohesion:s-Clique • Connection:Accessibility • Connection:Dependency • Connection:Influence • Connection:Influence Network Model • Connection:Link Connectivity • Connection:Max. Flow • Connection:Min. Cutset • Connection:Node Connectivity • Connection:Shortest Path • Equivalence:Regular • Equivalence:Role (Triad/Local) • Equivalence:SimRank • Equivalence:Structural • Neighbor:Degree • Neighbor:Ego-Net • Neighbor:Role Typology • Neighbor:Structural Hole • Position:Blockmodel • Position:Brokerage • Properties:Group • Properties:Network • Subgraph:Dyad Census • Subgraph:Dyadic Interaction(p1) • Subgraph:Triad Census • Subgraph:Triad Combination 	
--	--	--

User Interaction

<p><u>User Interaction</u></p>	<ul style="list-style-type: none"> • Add/Delete • Clone • Cut & Paste • Drag & Drop • Grid/Ruler • Groups • GUI • Layers • Pan 	<p>Comments: Graphs can be easily created or modified using the "Graph Editor". Nodes and links can be added/deleted with just a few mouse clicks.</p>
--	---	--

	<ul style="list-style-type: none"> • Reposition • Resize • Rotate • Scroll • Select • Spreadsheet • Tool Tips • Undo/Redo • Zoom 	
Deployment		
	<p>Type:</p> <ul style="list-style-type: none"> • Standalone Tool <p>OS:</p> <ul style="list-style-type: none"> • Linux • UNIX • Windows • Windows 2000 • Windows 95/98/ME • Windows NT • Windows XP 	
<u>OS Comments/Dependencies</u>	JRE 1.3 or higher	
<u>Interoperability</u>	<p>Import/export file formats: NTF, Excel, DL (UCINET), Pajek, CSV (Matrix/List)</p> <p>Image file formats: cgm, .eps, .gif, .jpg, .swf, .pdf, .png, .ps, .raw, .svg, .bmp, .ppm, .emf</p> <p>Database connectivity is provided in the Enterprise edition</p>	
<u>Scalability</u>	<p>Max Nodes: Unlimited</p> <p>Max Links: Unlimited</p>	<p>Comments: Large network size affects functional performance in analyses and visualization, especially Flow Betweenness, Clique, Community, Lambda Set or Equivalences finding.</p>
	<u>Hardware:</u>	<p><u>Users:</u></p> <ul style="list-style-type: none"> • Single <p><u>Availability:</u></p> <ul style="list-style-type: none"> • Commercially Available
<u>Cost</u>	\$101 - \$1000	<p>Comments: Enterprise, Professional, and Express editions with Normal Academic and Student pricing options</p>

<p>Images</p>	
	<p>Last Modified 2006-12-18 20:40:14</p>

<p>Name</p>	<p>NetMiner for Web</p>
<p>URL</p>	<p>http://www.netminer.com/NetMiner/product_03.jsp</p>
<p>Description</p>	<p>Brief description: An online social network analysis and visualization tools.</p> <p>Detailed description: Features:</p> <ol style="list-style-type: none"> 1. Advanced user interface which integrates network analysis and network visualization 2. High interactivity supported by control buttons for instant in depth analysis and visualization 3. 4 categories including 15 analysis tools which are most frequently used in SNA research 4. Multiple layer structure of network data file(supports 3 matrix layers) 5. Attribute and affiliation data can be easily attached to the relational/ adjacency data 6. Available at any time and any place if only connected to the Internet

Product Version/Status	1.0	
Context		
Main Functionalities	<ul style="list-style-type: none"> Automated Layout Graph Manipulation Graph Viewing Network Analysis 	Comments:
Domain	<ul style="list-style-type: none"> Any Social Networks 	Comments:
Network Representation		
Links	<ul style="list-style-type: none"> Coloured Labelled User Defined 	Comments:
Nodes	<ul style="list-style-type: none"> Coloured Labelled User Defined 	
Layout Algorithms	<ul style="list-style-type: none"> Concentric Spring 	Comments:
Dimensionality	<ul style="list-style-type: none"> 2D 	Comments:
Analysis		
Network Analysis	<ul style="list-style-type: none"> Centrality:Betweenness Centrality:Closeness Centrality:Degree Centrality:Eigenvector Cohesion:Bi-Component Cohesion:Clique Cohesion:Component Cohesion:Lambda Set Cohesion:n-Clan Cohesion:n-Clique Equivalence:Role (Triad/Local) Equivalence:Structural 	Comments:
User Interaction		
User Interaction	<ul style="list-style-type: none"> Add/Delete Drag & Drop GUI Spreadsheet 	Comments:
Deployment		

	Type: <ul style="list-style-type: none"> Standalone Tool Web-based OS: <ul style="list-style-type: none"> Multi-Platform (JAVA) 			
OS Comments/Dependencies	Java enabled Web browser			
Interoperability	Save dataset, report Import CSV Cannot save map diagram or map image			
Scalability	<table border="1"> <tr> <td>Max Nodes: <100</td> <td rowspan="2">Comments: Limited to 60 nodes</td> </tr> <tr> <td>Max Links: Unknown</td> </tr> </table>	Max Nodes: <100	Comments: Limited to 60 nodes	Max Links: Unknown
Max Nodes: <100	Comments: Limited to 60 nodes			
Max Links: Unknown				
	Hardware: Users: Availability: <ul style="list-style-type: none"> Freeware 			
Cost	Free Comments:			
References	Application link http://www.netminer.com/NetMiner/webdemo_out.jsp			
Last Modified	2006-12-18 20:41:38			

Name	NetVis	
URL	http://www.netvis.org/	
Description	Brief description: A web-based tool to visualize and analyse social networks. Detailed description:	
Product Version/Status	2.0	
Context		
Main Functionalities	<ul style="list-style-type: none"> Automated Layout Graph Manipulation Graph Viewing Network Analysis 	Comments:
Domain	<ul style="list-style-type: none"> Social Networks 	Comments:
Network Representation		
Dimensionality	<ul style="list-style-type: none"> 2D 	Comments:

	<ul style="list-style-type: none"> • 3D 	
Deployment		
	<u>Type:</u> <ul style="list-style-type: none"> • Open Source - GPL • Standalone Tool • Web-based 	<u>OS:</u>
<u>OS Comments/Dependencies</u>	apache 1.3.x or later php 4.2.x or later mySQL 3.23.x or later	
<u>Extensibility</u>	<ul style="list-style-type: none"> • PHP 	Comments:
	<u>Hardware:</u>	<u>Users:</u>
		<u>Availability:</u> <ul style="list-style-type: none"> • Freeware
<u>Cost</u>	Free	Comments:
Last Modified		
	2006-12-15 20:36:06	

Name	netViz Enterprise	
URL	http://www.netviz.com/index.asp	
Description	<p>Brief description: Create data driven multi-level layouts of network topologies.</p> <p>Detailed description: netVis creates accurate and useful top-down representations of a system by making use of multi-level hierarchies. You can view a top-level diagram of a network that spans a country, and from this view zoom in on a node which may represent a building. The view may then change to a floorplan of the building with the network topology overlaid on the floorplan.</p> <p>netVis is data drive. netViz was designed from the ground up to permit users to create dynamic, data-filled diagrams of complex information systems. netViz bridges the gap between data storage and data display – when you see a netViz diagram, you are actually looking at graphical reflections of object and relationship information in a database. As data in the databases changes, netVis views update to reflect the changes.</p>	
<u>Product Version/Status</u>	7.2	
Context		
<u>Main Functionalities</u>	<ul style="list-style-type: none"> • Automated Layout • Graph Manipulation • Graph Viewing 	Comments:

<u>Domain</u>	<ul style="list-style-type: none"> • Computer Networks 	Comments:
Network Representation		
<u>Links</u>	<ul style="list-style-type: none"> • User Defined 	Comments: Each graphic object in netViz can have an unlimited number of custom data fields associated with it. When you select an object, all the details about that object are displayed.
<u>Nodes</u>	<ul style="list-style-type: none"> • User Defined 	
<u>Layout Algorithms</u>	<ul style="list-style-type: none"> • Hierarchical • Orthogonal • Spring 	Comments:
<u>Dimensionality</u>	<ul style="list-style-type: none"> • 2D • 3D • Geospatial 	Comments:
User Interaction		
<u>User Interaction</u>	<ul style="list-style-type: none"> • Add/Delete • Cut & Paste • Drag & Drop • Drill down • Filter • GUI • Layers • Search • Select • Web/CGI • Zoom 	Comments:
Deployment		
	<u>Type:</u> <ul style="list-style-type: none"> • Standalone Tool 	<u>OS:</u> <ul style="list-style-type: none"> • Windows 2000 • Windows XP
<u>Extensibility</u>	<ul style="list-style-type: none"> • C++ • Visual Basic 	Comments: The netViz Developer's Kit (nDK) allows you to use either the netViz Application Programming Interface (API) or OLE Automation to enhance and extend netViz functionality.
<u>Interoperability</u>	import/export to Visio Import bmp, wmf, dxf as backgrounds Can communicate with any ODBC-compliant database.	
<u>Scalability</u>	Max Nodes: Unlimited Max Links: Unlimited	Comments: If scalability does become in issue, netViz can be easily distributed among multiple desktop licenses, and among multiple Enterprise servers.

	<p>Hardware:</p> <ul style="list-style-type: none"> • 3D Graphics accelerator 	<p>Users:</p> <ul style="list-style-type: none"> • Multiple • Networked 	<p>Availability:</p> <ul style="list-style-type: none"> • Commercially Available
Cost	\$1001 - \$5000	<p>Comments: netViz Enterprise Project Author: \$4995 netViz 3D Desktop: \$2862 netViz 2D Professional Desktop: \$1785</p>	
Last Modified	2006-12-18 20:49:28		

Name	NetVizor		
URL	http://www.gvu.gatech.edu/ii/netviz/		
Description	<p>Brief description: NetVizor is a tool designed to visualize the network models generated by the Georgia Tech Internet Topology Modeler.</p> <p>Detailed description: From Abstract:</p> <p>Real-world data networks are large, making them difficult to analyze. Thus, analysts often generate network models of a more tractable scale to perform simulations and analyses, but even these models need to be fairly large. Because these networks do not directly correspond to any particular network, it is often difficult for the user to construct a mental model of the network. We present a network model visualization system developed with networking researchers to help improve the design and analysis of these topologies. In particular, this system supports manipulation of the network layout based on hierarchical information; a novel display technique to reduce clutter around transit routers; and the mixture of manual and automatic interaction in the layout phase.</p>		
Product Version/Status	website last update on 07-Nov-2003		
Context			
Main Functionalities	<ul style="list-style-type: none"> • Automated Layout • Graph Manipulation • Graph Viewing 	Comments:	
Domain	<ul style="list-style-type: none"> • Any • Computer Networks 	Comments:	
Network Representation			
Links	<ul style="list-style-type: none"> • Coloured 	Comments:	
Nodes	<ul style="list-style-type: none"> • Coloured • Labelled 		

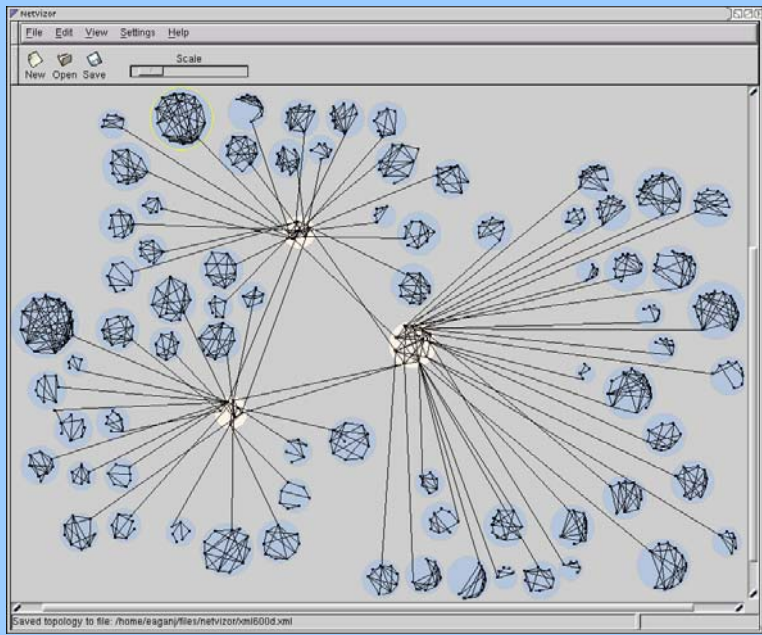
<u>Dimensionality</u>	<ul style="list-style-type: none"> • 2D 	Comments:
User Interaction		
<u>User Interaction</u>	<ul style="list-style-type: none"> • Add/Delete • Drag & Drop • GUI 	Comments:
Deployment		
	<u>Type:</u> <ul style="list-style-type: none"> • Standalone Tool 	<u>OS:</u>
	<u>Hardware:</u>	<u>Users:</u>
		<u>Availability:</u> <ul style="list-style-type: none"> • Research Prototype
Images		
	 <p>The image shows a screenshot of a network visualization application named 'netvizor'. The window title is 'netvizor' and it has a menu bar with 'File', 'Edit', 'View', 'Settings', and 'Help'. Below the menu bar is a toolbar with icons for 'New', 'Open', and 'Save', and a 'Scale' slider. The main area displays a complex network graph with numerous nodes, each represented by a 3D wireframe polyhedron. The nodes are interconnected by a dense web of edges. The graph is centered around two main hubs. At the bottom of the window, a status bar indicates 'Saved topology to file: /home/sagany/files/netvizor/nml600d.xml'.</p>	
Last Modified	2006-12-18 19:14:39	

Name	NetworkX
URL	https://networkx.lanl.gov/wiki
Description	<p>Brief description: NetworkX (NX) is a Python package for the creation, manipulation, and study of the structure, dynamics, and functions of complex networks.</p> <p>Detailed description: Features:</p>

	<ul style="list-style-type: none"> * Allows for 1M+ nodes, 10M+ edges * Includes standard graph-theoretic and statistical physics functions * Easy exchange of network algorithms between applications, disciplines, and platforms * Includes many classic graphs and synthetic networks * Nodes and edges can be "anything" (e.g. time-series, text, images, XML records) * Exploits existing code from high-quality legacy software in C, C++, Fortran, etc. * Open source (encourages community input) * Unit-tested <p>Additional benefits due to Python:</p> <ul style="list-style-type: none"> * Allows fast prototyping of new algorithms * Easy to teach * Multi-platform * Allows easy access to almost any database 	
Product Version/Status	0.32 (2006-09-29 17:13)	
Context		
Main Functionalities	<ul style="list-style-type: none"> • Automated Layout • Graph Manipulation • Graph Viewing • Network Analysis 	Comments:
Domain	<ul style="list-style-type: none"> • Any 	Comments:
	User Role:	Activity:
Network Representation		
Type	<ul style="list-style-type: none"> • Directed • Undirected 	
Links	<ul style="list-style-type: none"> • User Defined • Weighted 	Comments: Nodes and edges can be "anything" (e.g. time-series, text, images, XML records)
Nodes	<ul style="list-style-type: none"> • User Defined 	
Layout Algorithms	<ul style="list-style-type: none"> • Circular • Random • Shell • Spectral • Spring 	Comments:
Dimensionality	<ul style="list-style-type: none"> • 2D 	Comments:
Analysis		
Network Analysis	<ul style="list-style-type: none"> • Centrality • Centrality:Betweenness • Centrality:Closeness 	Comments:

	<ul style="list-style-type: none"> • Centrality:Degree • Centrality:Edge Betweenness • Cohesion:n-Clique • Cohesion:s-Clique • Connection:All Pairs Shortest Path • Connection:Connectivity • Connection:Distance • Connection:Path • Connection:Shortest Path • Topological Sort • Traversal:Breadth First Search • Traversal:Depth First Search 		
Deployment			
	<p>Type:</p> <ul style="list-style-type: none"> • Components for tool building • Open Source - GPL 	<p>OS:</p> <ul style="list-style-type: none"> • Multi-Platform 	
<u>OS Comments/Dependencies</u>	<p>Python version 2.3 or later http://www.python.org/</p> <p>Optional packages to enable drawing networks:</p> <ul style="list-style-type: none"> * Matplotlib http://matplotlib.sourceforge.net/ * pygraphviz http://networkx.lanl.gov/pygraphviz/ * Graphviz http://graphviz.org/ * numpy http://numpy.scipy.org/ <p>Optional useful packages:</p> <ul style="list-style-type: none"> * Ipython http://ipython.scipy.org/ * SciPy http://scipy.org/ * PyGSL http://pygsl.sourceforge.net/ * sAsync http://foss.eepatents.com/sAsync * PyYAML http://pyyaml.org/ 		
<u>Extensibility</u>	<ul style="list-style-type: none"> • Python 	Comments:	
<u>Scalability</u>	<p>Max Nodes: Unlimited</p> <p>Max Links: Unlimited</p>	<p>Comments: Allows for 1M+ nodes, 10M+ edges</p>	
	<u>Hardware:</u>	<u>Users:</u>	<p><u>Availability:</u></p> <ul style="list-style-type: none"> • Freeware • In Development
<u>Cost</u>	Free	Comments:	

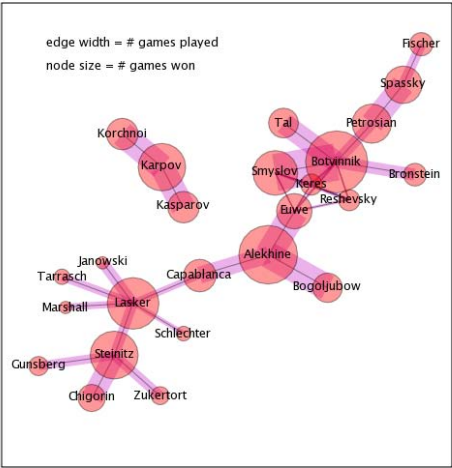
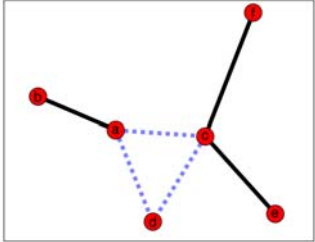
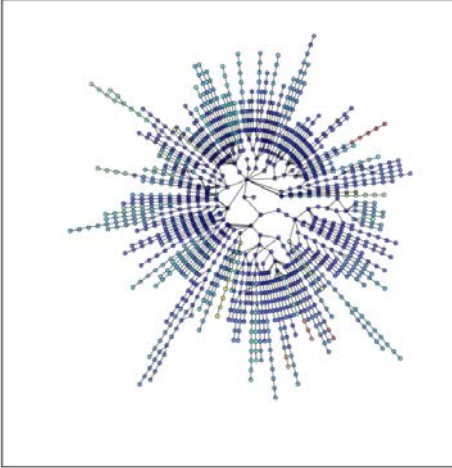
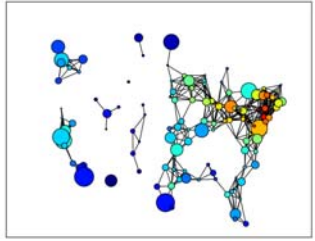
Images	<p>World Chess Championship Games: 1886 - 1985</p> 	
		
References	API docs https://networkx.lanl.gov/reference/networkx/	
Last Modified	2006-12-10 16:39:16	

Name	Neuron Diagram for .Net
URL	http://www.nevron.com/Diagramming.aspx?nav=DiagramWinFormsNav&content=DiagramWinForms
Description	<p>Brief description: Nevron Diagram for .NET (Windows Forms and ASP.NET) is an extensible diagramming framework for creating diagramming solutions in WinForms and WebForms.</p> <p>Detailed description:</p>

	<p>Main features:</p> <p>Diagram Document Object Model - The Diagram Document Object Model (DOM) represents the set of elements, which you can use to build a diagramming document.</p> <p>Shape Factories - Nevron Diagram for .NET comes equipped with numerous predefined vector shapes, which can come handy in many applications.</p> <p>WinForm Views, Controller and Tools - In WinForm the viewing and editing of documents is achieved with the help of views and controllers.</p> <p>Layouts - Layouts can help you automatically arrange diagram elements.</p> <p>Templates - DOM content can easily be created with the help of programmable templates.</p> <p>Diagram Designer Components - Nevron Diagram for .NET implements a complete set of components which can help you create a feature rich diagram designer in minutes.</p>	
Product Version/Status	6.3	
Context		
Main Functionalities	<ul style="list-style-type: none"> Automated Layout Graph Manipulation Graph Viewing 	Comments:
Domain	<ul style="list-style-type: none"> Any 	Comments:
Network Representation		
Links		Comments:
Nodes	<ul style="list-style-type: none"> Symbol 	
Layout Algorithms	<ul style="list-style-type: none"> Force-Directed Table Tree 	Comments: All layouts can easily be extended. You can also create your custom layouts
Dimensionality	<ul style="list-style-type: none"> 2D 	Comments:
Visual Enhancements		
Visual Enhancements	<ul style="list-style-type: none"> Animation/Video 	Comments: Layout Animation - the effect of all layouts can be animated
User Interaction		
User Interaction	<ul style="list-style-type: none"> Add/Delete Cut & Paste Drag & Drop Draw Grid/Ruler 	Comments:

	<ul style="list-style-type: none"> • Groups • GUI • Layers • Macros/Batch Processing • Pan • Reposition • Select • Undo/Redo 	
--	--	--

Deployment

	<p>Type:</p> <ul style="list-style-type: none"> • Components for tool building • Web-based 	<p>OS:</p> <ul style="list-style-type: none"> • Windows • Windows 2000 • Windows 2003 • Windows NT • Windows XP
--	---	---

Extensibility	<ul style="list-style-type: none"> • .NET • C# • Visual Basic 	<p>Comments: Most features are fully extensible. For instance: - Any element of the DOM can be subclassed or its behavior can be overridden - Layouts can be extended or custom layouts can be added</p>
----------------------	--	---

	<p>Hardware:</p>	<p>Users:</p>	<p>Availability:</p> <ul style="list-style-type: none"> • Commercially Available
--	-------------------------	----------------------	--

Cost	\$101 - \$1000	<p>Comments: Nevron Diagram for .NET Professional: \$589 Nevron Diagram for .NET Enterprise: \$889</p>
-------------	----------------	---

Images

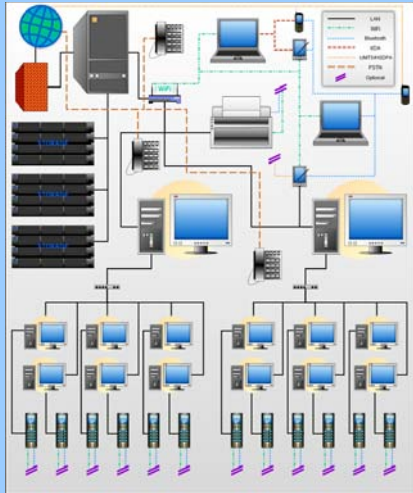
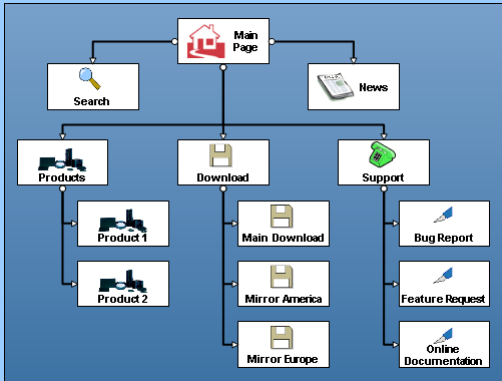
Images		
---------------	---	--

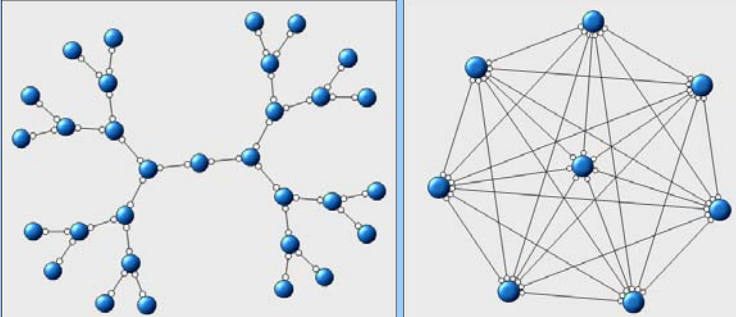
		
References	Online manual: http://www.nevron.com/DotNetVision/Index.htm	
Last Modified	2006-12-18 19:14:57	

Name	NIVA	
Description	<p>Brief description: A network intrusion visualization with haptic integration</p> <p>Detailed description: From Abstract: The explosive growth of malicious activities on worldwide communication networks, such as the Internet, has highlighted the need for efficient intrusion detection systems. The efficiency of traditional intrusion detection systems is limited by their inability to effectively relay relevant information due to their lack of interactive/immersive technologies. In this paper, we explore several network visualization techniques geared towards intrusion detection on small and large-scale networks. We also examine the use of haptics in network intrusion visualization. By incorporating concepts from electromagnetics, fluid dynamics, and gravitational theory, we show that haptic technologies can provide another dimension of information critical to the efficient visualization of network intrusion data. Furthermore, we explore the applicability of these visualization techniques in conjunction with commercial network intrusion detectors. Finally, we present a network intrusion visualization application with haptic integration, NIVA, which allows the analyst to interactively investigate as well as efficiently detect structured attacks across time and space using advanced interactive three-dimensional displays.</p>	
Context		
Main Functionalities	<ul style="list-style-type: none"> • Automated Layout • Graph Manipulation • Graph Viewing • Network management/discovery • Network Security/IDS 	Comments:
Domain	<ul style="list-style-type: none"> • Computer Networks 	Comments:
	<p>User Role:</p> <p>Activity:</p> <ul style="list-style-type: none"> • Investigate • Monitor 	

	<ul style="list-style-type: none"> Track
Network Representation	
<u>Links</u>	<ul style="list-style-type: none"> Coloured
<u>Nodes</u>	<ul style="list-style-type: none"> Coloured
<u>Layout Algorithms</u>	<ul style="list-style-type: none"> MDS Spring
<u>Dimensionality</u>	<ul style="list-style-type: none"> 3D
User Interaction	
<u>User Interaction</u>	<ul style="list-style-type: none"> Sensory:Touch
Deployment	
	<u>Type:</u> <ul style="list-style-type: none"> Standalone Tool <u>OS:</u>
	<u>Hardware:</u> <u>Users:</u> <u>Availability:</u> <ul style="list-style-type: none"> Research Prototype
References	
<u>References</u>	see paper "Network Intrusion Visualization with NIVA, an Intrusion Detection Visual Analyzer with Haptic Integration" 00998969.pdf
Last Modified	2006-12-17 17:59:58

Name	Nomad
URL	http://netmon.ncl.ac.uk/
Description	<p>Brief description: A network monitor and mapper.</p> <p>Detailed description: Nomad is a network mapping program designed to automatically discover a local network, using SNMP to identify network devices and work out how they are physically connected together. The network is then presented as a topology diagram with simple integrated monitoring. Changes in the network are reflected in the diagram which continuously updates, and you can customise your own views of the network map with various views and filters.</p>
Product Version/Status	0.3.2 as of 06/10/28 (released 03/04/23)

Context		
<u>Main Functionalities</u>	<ul style="list-style-type: none"> Automated Layout Network management/discovery 	Comments:
<u>Domain</u>	<ul style="list-style-type: none"> Computer Networks 	Comments:
	<u>User Role:</u>	<u>Activity:</u> <ul style="list-style-type: none"> Monitor
Network Representation		
<u>Layout Algorithms</u>		Comments: Discovery and mapping of layer 3 and layer 2 devices.
<u>Dimensionality</u>	<ul style="list-style-type: none"> 2D 	Comments:
User Interaction		
<u>User Interaction</u>	<ul style="list-style-type: none"> Add/Delete Drag & Drop GUI Scroll Search Select Zoom 	Comments:
Deployment		
	<u>Type:</u> <ul style="list-style-type: none"> Open Source - GPL Standalone Tool 	<u>OS:</u> <ul style="list-style-type: none"> Linux UNIX
<u>Extensibility</u>	<ul style="list-style-type: none"> C++ 	Comments:
	<u>Hardware:</u>	<u>Users:</u>
		<u>Availability:</u> <ul style="list-style-type: none"> Freeware
<u>Cost</u>	Free	Comments:

<p>Images</p>	
<p>Last Modified</p>	<p>2006-12-18 19:15:30</p>

<p>Name</p>	<p>NV2D</p>	
<p>URL</p>	<p>http://web.mit.edu/bshi/Public/nv2d/</p>	
<p>Description</p>	<p>Brief description: NV2D is a graph visualization and layout tool written in Java that can run either as a standalone application or an applet embedded in a web browser</p> <p>Detailed description:</p>	
<p>Product Version/Status</p>	<p>0.7 2005-06-13 06:00</p>	
<p>Context</p>		
<p>Main Functionalities</p>	<ul style="list-style-type: none"> Automated Layout Graph Manipulation Graph Viewing 	<p>Comments:</p>
<p>Domain</p>	<ul style="list-style-type: none"> Any Social Networks 	<p>Comments:</p>
<p>Network Representation</p>		

<u>Type</u>	<ul style="list-style-type: none"> Directed Undirected 	
<u>Links</u>	<ul style="list-style-type: none"> Coloured 	Comments:
<u>Dimensionality</u>	<ul style="list-style-type: none"> 2D 	Comments:
Analysis		
<u>Network Analysis</u>	<ul style="list-style-type: none"> Connection:Shortest Path 	Comments:
User Interaction		
<u>User Interaction</u>	<ul style="list-style-type: none"> Drag & Drop GUI Pan Reposition Select Web/CGI Zoom 	Comments:
Deployment		
	<u>Type:</u> <ul style="list-style-type: none"> Open Source - GPL Standalone Tool Web-based 	<u>OS:</u> <ul style="list-style-type: none"> Multi-Platform (JAVA)
<u>Extensibility</u>	<ul style="list-style-type: none"> JAVA 	Comments:
<u>Interoperability</u>	Import for GraphML	
	<u>Hardware:</u>	<u>Users:</u> <u>Availability:</u> <ul style="list-style-type: none"> Freeware
<u>Cost</u>	Free	Comments:
		

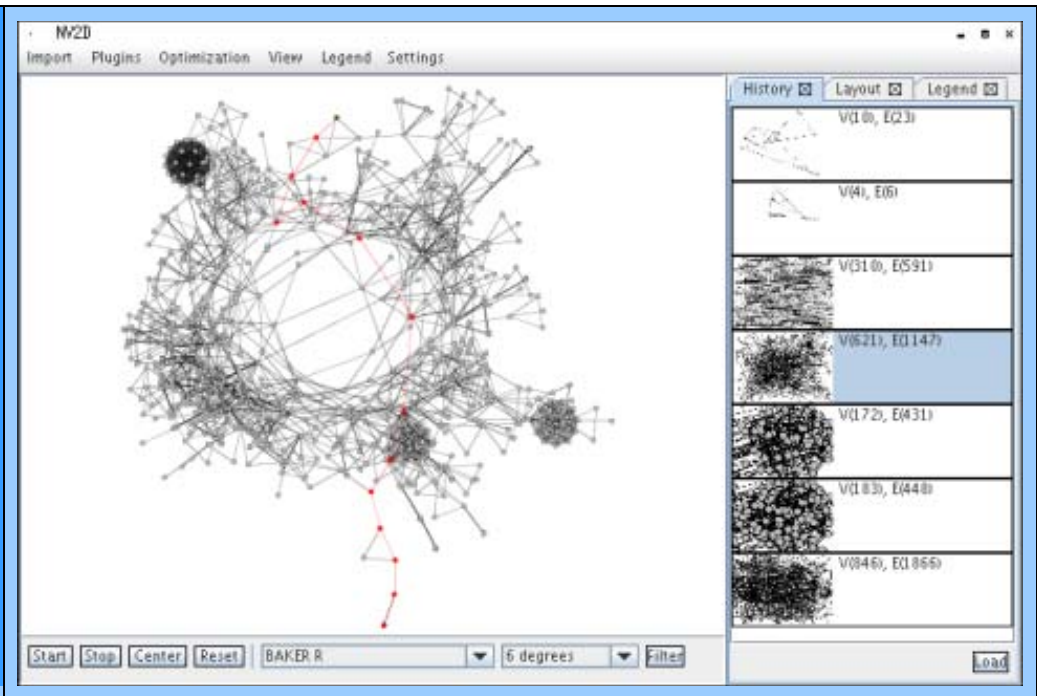
<p>Images</p>	
<p>Last Modified</p>	<p>2006-12-18 19:23:40</p>

<p>Name</p>	<p>OpenNMS</p>	
<p>URL</p>	<p>http://www.opennms.org/index.php/Main_Page</p>	
<p>Description</p>	<p>Brief description: OpenNMS is an open-source, enterprise-grade network management platform</p> <p>Detailed description: The goal is for OpenNMS to be a truly distributed, scalable platform for all aspects of the FCAPS network management model, and to make this platform available to both open source and commercial applications.</p> <p>Currently, OpenNMS focuses on three main areas:</p> <p>Service Polling - determining service availability and reporting on same. Data Collection - collecting, storing and reporting on network information as well as generating thresholds. Event and Notification Management - receiving events, both internal and external, and using those events to feed a robust notification system, including escalation.</p>	
<p>Product Version/Status</p>	<p>1.2.8 as of 06/10/28 (released 06/06/08)</p>	
<p>Context</p>		
<p>Main Functionalities</p>	<ul style="list-style-type: none"> • Network management/discovery 	<p>Comments:</p>
<p>Domain</p>	<ul style="list-style-type: none"> • Computer Networks 	<p>Comments:</p>

	<p>User Role:</p>	<p>Activity:</p> <ul style="list-style-type: none"> • Monitor • Track
Network Representation		
<p>Layout Algorithms</p>		<p>Comments:</p> <p>The default installation does not contain a mapping component. A group within OpenNMS is currently working on a map and some map code as already been contributed.</p> <p>http://www.opennms.org/index.php/FAQ-About#Q: Does_OpenNMS_Have_a_Map.3F http://www.opennms.org/index.php/Maps_In_Trunk</p>
User Interaction		
<p>User Interaction</p>	<ul style="list-style-type: none"> • GUI • Web/CGI 	<p>Comments:</p>
Deployment		
	<p>Type:</p> <ul style="list-style-type: none"> • Open Source - GPL • Standalone Tool 	<p>OS:</p> <ul style="list-style-type: none"> • Linux • Mac OS X • Solaris
<p>OS Comments/Dependencies</p>	<p>Supported OSes</p> <ul style="list-style-type: none"> * Linux <ul style="list-style-type: none"> o RHEL/CentOS (3 and 4) o Debian Sarge o Fedora Core (2, 3, 4 and 5) o Mandrake 9.2 and 10 o SuSE (9 and 10) o Red Hat Linux (7, 8 and 9) * Solaris 8 and Solaris 9 (SPARC) * Solaris 8 and Solaris 9 (x86) * Mac OS X (Panther) <p>Dependencies:</p> <ul style="list-style-type: none"> -Java Virtual machine -Tomcat4 (version 4.1 or greater) -RRDtool -PostgreSQL 	
<p>Extensibility</p>	<ul style="list-style-type: none"> • JAVA 	<p>Comments:</p>
<p>Interoperability</p>	<p>Provides CSV and XML export</p>	

	<u>Hardware:</u>	<u>Users:</u>	<u>Availability:</u>
			<ul style="list-style-type: none"> • Freeware • In Development



Images

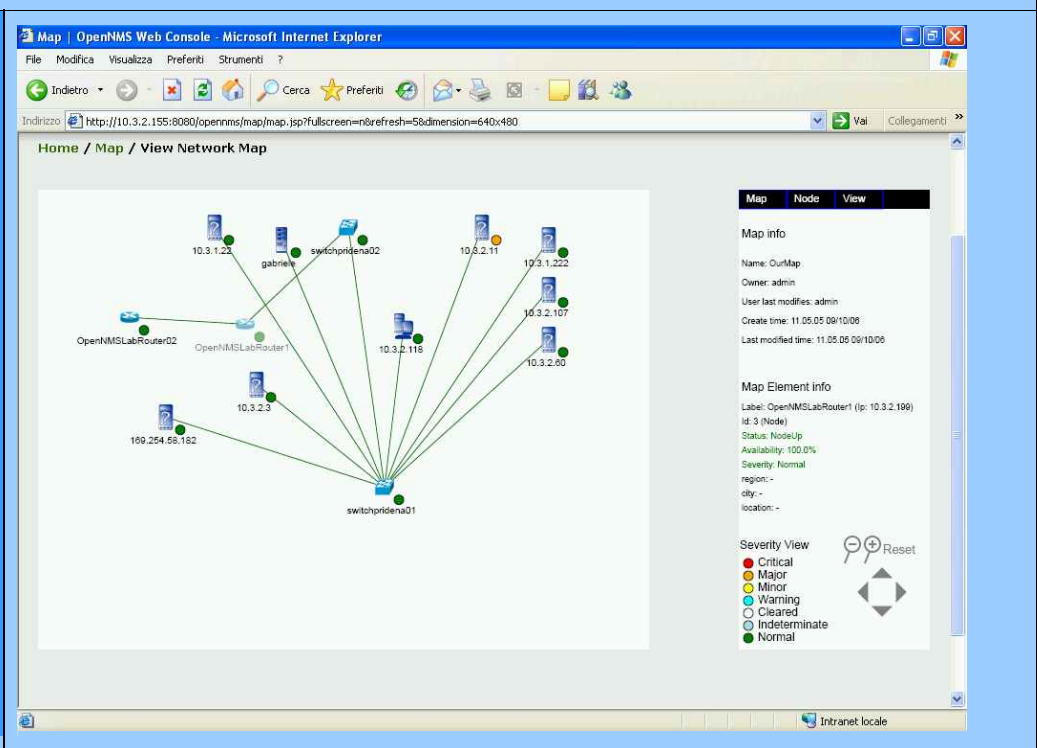

Last Modified	2006-12-18 19:24:08
----------------------	---------------------

Name	Otter	
URL	http://www.caida.org/tools/visualization/otter/	
Description	Brief description: A general-purpose network visualization tool Detailed description:	
Product Version/Status	Still being maintained, but there is no longer any active development.	
Context		
Main Functionalities	<ul style="list-style-type: none"> • Automated Layout • Graph Viewing 	Comments:
Domain	<ul style="list-style-type: none"> • Any 	Comments:
Network Representation		
Layout Algorithms	<ul style="list-style-type: none"> • Circular 	Comments:

	<ul style="list-style-type: none"> Coordinate 	
<u>Dimensionality</u>	<ul style="list-style-type: none"> 2D Geospatial 	Comments: For coordinate-based layout the coordinates can be either geographical (lat./long.) or Cartesian (x,y) coordinates.
User Interaction		
<u>User Interaction</u>	<ul style="list-style-type: none"> Filter GUI Pan Zoom 	Comments:
Deployment		
	<u>Type:</u> <ul style="list-style-type: none"> Open Source Standalone Tool 	<u>OS:</u>
<u>Extensibility</u>	<ul style="list-style-type: none"> JAVA Perl 	Comments:
	<u>Hardware:</u>	<u>Users:</u>
		<u>Availability:</u> <ul style="list-style-type: none"> Freeware
<u>Cost</u>	Free	Comments:
References		
	http://www.caida.org/tools/visualization/otter/paper/	
Last Modified	2006-12-18 19:24:29	

Name	P-Graphs
URL	http://eclectic.ss.uci.edu/~drwhite/pgraph/p-graphs.html
Description	<p>Brief description: The p-graph is designed to graphically represent social networks that include, but are not limited to, kinship and marriage ties.</p> <p>Detailed description:</p>
Last Modified	
	2006-12-10 16:39:16

Name	P.I.G.A.L.E.
-------------	---------------------

URL	http://pigale.sourceforge.net/	
Description	<p>Brief description: Public Implementation of a Graph Algorithm Library and Editor - a graph editor and a C++ algorithm library essentially concerned with planar graphs.</p> <p>Detailed description:</p>	
Product Version/Status	1.3.5 (2006-07-07 05:17)	
Context		
Main Functionalities	<ul style="list-style-type: none"> Automated Layout Graph Manipulation Graph Viewing Network Analysis 	Comments:
Network Representation		
Links	<ul style="list-style-type: none"> Coloured 	Comments:
Layout Algorithms	<ul style="list-style-type: none"> Planar Planar:Convex Planar:FPP Planar:Schnyder Spring Spring (Tutte) 	Comments:
Dimensionality	<ul style="list-style-type: none"> 2D 3D 	Comments:
Analysis		
Network Analysis	<ul style="list-style-type: none"> Traversal:Depth First Search 	Comments:
User Interaction		
User Interaction	<ul style="list-style-type: none"> Add/Delete Drag & Drop Grid/Ruler GUI Pan Reposition Undo/Redo Zoom 	Comments:
Deployment		
	<p>Type:</p> <ul style="list-style-type: none"> Components for tool building Open Source - GPL Standalone Tool 	<p>OS:</p> <ul style="list-style-type: none"> Linux Mac OS X UNIX Windows

Extensibility	<ul style="list-style-type: none"> C++ 	Comments:
Interoperability	A client/server is provided so that other programs can interface to Pigale	
	Hardware:	Users:
		Availability: <ul style="list-style-type: none"> Freeware In Development
Cost	Free	Comments:



Images

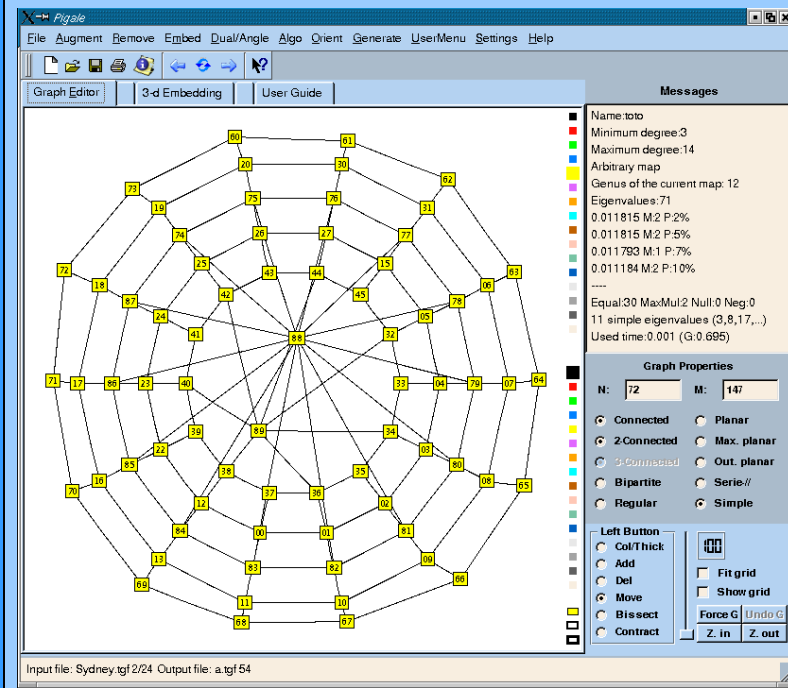

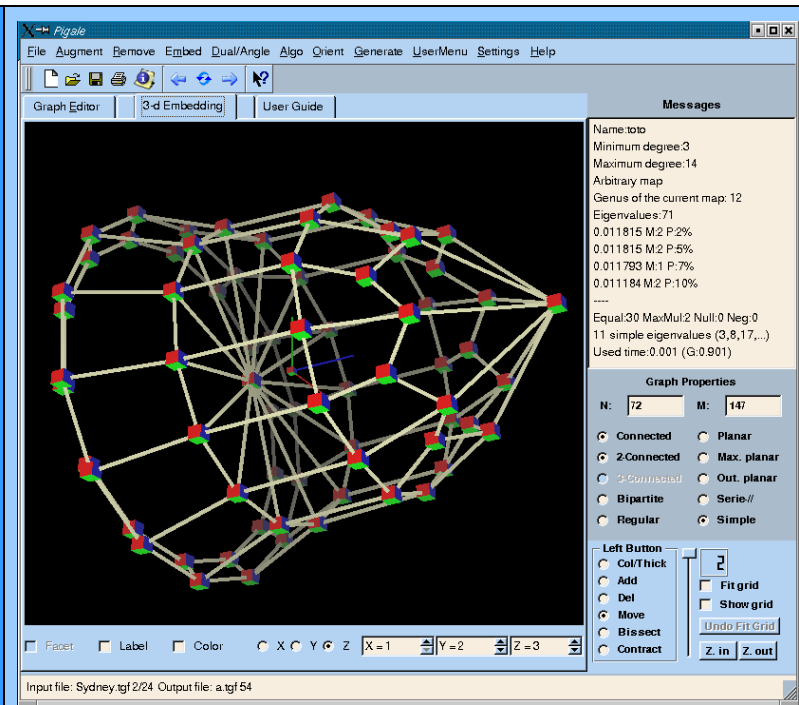
	 <p>The screenshot shows the Pajek software window. The main view displays a 3D graph with nodes represented by small colored cubes and edges as thin lines. The interface includes a menu bar (File, Augment, Remove, Embed, Dual/Angle, Algo, Orient, Generate, User/Menu, Settings, Help), a toolbar, and a 'Messages' panel on the right. The 'Messages' panel contains the following text:</p> <pre>Name: toto Minimum degree: 3 Maximum degree: 14 Arbitrary map Genus of the current map: 12 Eigenvalues: 71 0.011815 M:2 P:2% 0.011815 M:2 P:5% 0.011793 M:1 P:7% 0.011184 M:2 P:10% ---- Equal: 30 MaxMul: 2 Null: 0 Neg: 0 11 simple eigenvalues (3, 8, 17, ...) Used time: 0.001 (G: 0.901)</pre> <p>Below the main view, there are two smaller 2D graph visualizations. The left one shows a graph with nodes numbered 01 to 24, and the right one shows a similar graph with nodes numbered 01 to 24. The 'Graph Properties' panel on the right shows N: 72, M: 147, and various options like Connected, Planar, 2-Connected, Max. planar, 2-Component, Out. planar, Bipartite, Serie//, Regular, and Simple. The 'Left Button' panel includes options like Col/Thick, Add, Del, Move, Bisect, Contract, Fit grid, Show grid, Undo Fit Grid, Z.in, and Z.out. The status bar at the bottom indicates 'Input file: Sydney.tgf 2/24 Output file: a.tgf 54'.</p>
Last Modified	2006-12-10 16:39:16

Name	Pajek
URL	http://vlado.fmf.uni-lj.si/pub/networks/pajek/
Description	<p>Brief description: Pajek is used for the visualization and analysis of large networks.</p> <p>Detailed description: The main motivation for development of Pajek was the observation that there exist several sources of large networks that are already in machine-readable form. Pajek should provide tools for analysis and visualization of such networks: collaboration networks, organic molecule in chemistry, protein-receptor interaction networks, genealogies, Internet networks, citation networks, diffusion (AIDS, news, innovations) networks, data-mining (2-mode networks), etc.</p>

	<p>The main goals in the design of Pajek are:</p> <ul style="list-style-type: none"> • to support abstraction by (recursive) decomposition of a large network into several smaller networks that can be treated further using more sophisticated methods; • to provide the user with some powerful visualization tools; • to implement a selection of efficient (subquadratic) algorithms for analysis of large networks. 	
Product Version/Status	Version 1.17 (released 06/11/11)	
Context		
Main Functionalities	<ul style="list-style-type: none"> • Automated Layout • Graph Manipulation • Graph Viewing • Network Analysis 	Comments:
Domain	<ul style="list-style-type: none"> • Any 	Comments:
Network Representation		
Links	<ul style="list-style-type: none"> • Coloured • Labelled 	Comments:
Nodes	<ul style="list-style-type: none"> • Coloured • Labelled 	
Layout Algorithms	<ul style="list-style-type: none"> • Circular • Random • Spring FR • Spring KK 	Comments:
Dimensionality	<ul style="list-style-type: none"> • 2D • 3D 	Comments:
Analysis		
General Analysis		Comments: Advanced statistical analysis is available through an external free package called R
Network Analysis	<ul style="list-style-type: none"> • Centrality • Cluster Recognition • Connection:Flow • Connection:Max. Flow • Connection:Shortest Path • k-Neighbor • Partition 	Comments:
User Interaction		
User Interaction	<ul style="list-style-type: none"> • Add/Delete • GUI • Layers • Macros/Batch 	Comments: The graph visualization window offers limited interaction capabilities.

	<ul style="list-style-type: none"> Processing Rotate 	
--	--	--

Deployment

	Type: <ul style="list-style-type: none"> Standalone Tool 	OS: <ul style="list-style-type: none"> Windows
--	--	--

Interoperability	Pajek can export to the following image formats: EPS, SVG, VRML, BMP. Pajek also provides exports to lesser known file formats: MDL MOL file, and Kinemages.	
-------------------------	---	--

Scalability	Max Nodes: Unlimited Max Links: Unlimited	Comments: Pajek was specifically created to handle large networks; therefore, many of the algorithms that Pajek employ tend to scale very well.
--------------------	--	---

	Hardware:	Users: <ul style="list-style-type: none"> Single 	Availability: <ul style="list-style-type: none"> Freeware In Development In Use
--	------------------	--	---

Cost	Free - For noncommercial use	Comments:
-------------	------------------------------	------------------

Images

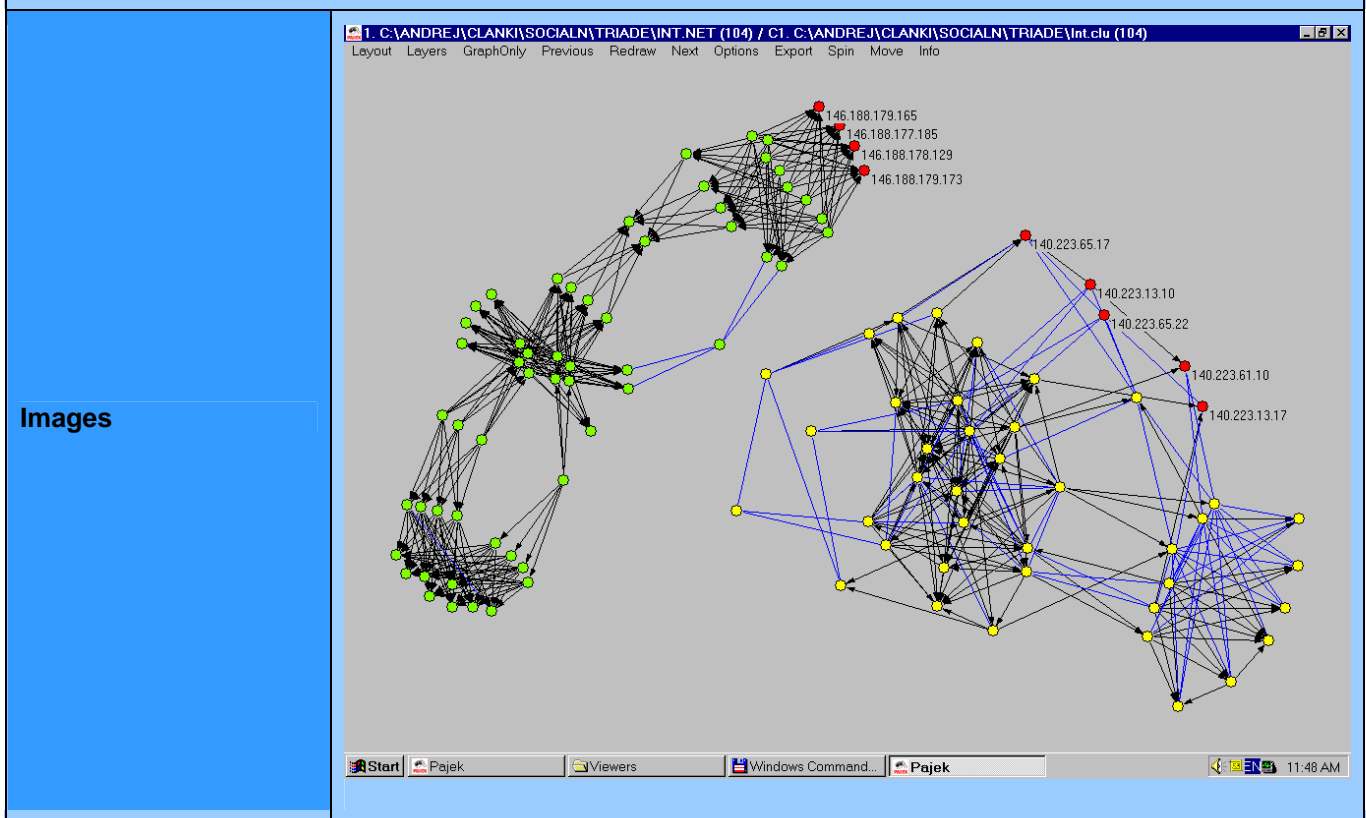

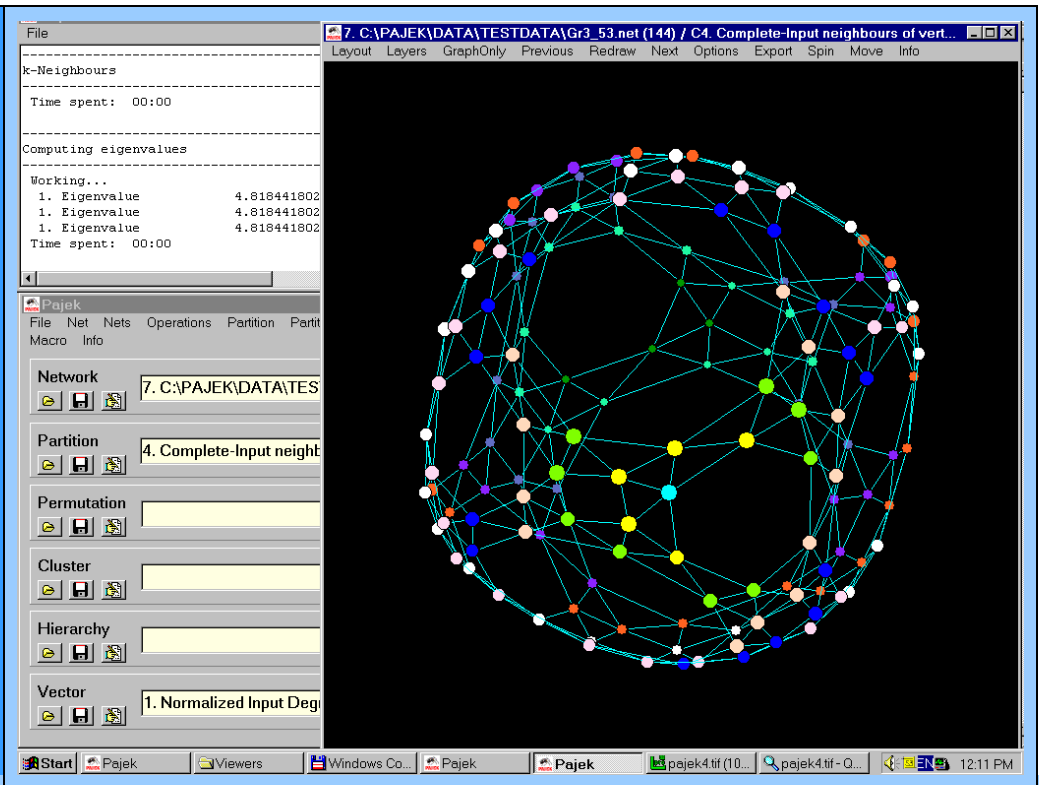
	
References	Participant in graph drawing contest http://www.gd2005.org/
Last Modified	2006-12-18 22:27:45

Name	Passive/Active Network Monitoring Tool (PNMT/ANMT)
URL	http://www.crc.ca/en/html/crc/home/research/network/system_apps/network_systems/network_security/methodologies/crc_networkdiscovery
Description	<p>Brief description: This tool automatically discovers layer 2 and layer 3 network devices and create a corresponding network map.</p> <p>Detailed description: The Network Security Research Group at the Communication Research Centre (CRC) has developed a Passive Network Monitoring Tool (PNMT) and an Active Network Monitoring Tool (ANMT) for network auto-discovery. Techniques used in these tools include the capability to discover active nodes, operating systems, the node's role in the network, the system uptime, the services offered, the protocols supported, the IP network interface configuration and the network topology at different levels of specification (physical, logical). The prototypes provide this information to network managers and security analysts via a graphical user interface. By combining a number of different information acquisition techniques and information sources, the tools are able to construct a comprehensive and trustworthy picture of the network. PNMT and ANMT can be used together to allow near real-time awareness of the security posture of ever-changing networks. This approach can help network administrators exercise control and better anticipate upcoming security problems.</p>
Context	

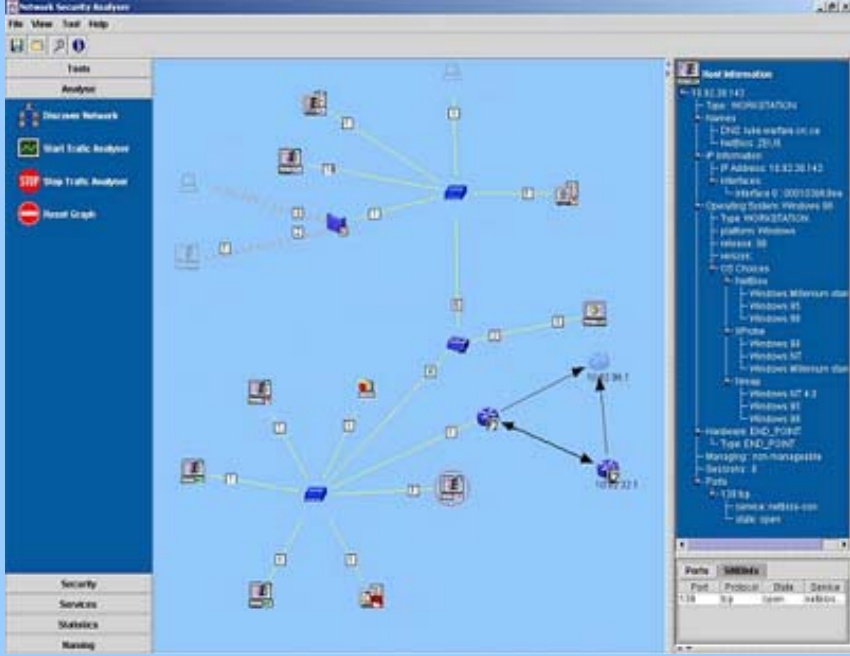
<p>Main Functionalities</p>	<ul style="list-style-type: none"> Automated Layout Graph Manipulation Graph Viewing Network management/discovery 	<p>Comments:</p>
<p>Domain</p>	<ul style="list-style-type: none"> Computer Networks 	<p>Comments:</p>
<p>User Role:</p> <p>Activity:</p> <ul style="list-style-type: none"> Monitor Track 		
<p>Network Representation</p>		
<p>Dimensionality</p>	<ul style="list-style-type: none"> 2D 	<p>Comments:</p>
<p>Deployment</p>		
<p>Type:</p> <ul style="list-style-type: none"> Standalone Tool <p>OS:</p>		
<p>OS Comments/Dependencies</p>	<p>Dependencies: nmap Xprobe</p>	
<p>Hardware:</p> <p>Users:</p> <p>Availability:</p> <ul style="list-style-type: none"> Research Prototype 		
<p>Images</p>		
<p>Images</p>	 <p>The screenshot shows the Network Security Analyzer interface. On the left, there is a 'Tools' menu with options like 'Analyze Network', 'Start Traffic Analysis', 'Stop Traffic Analysis', and 'Reset Graph'. The main area displays a network graph with various nodes and connections. On the right, a 'Host Information' panel shows details for a host with IP address 10.0.2.142, including its OS (Windows XP), platform (Windows), and various services and ports.</p>	
<p>Last Modified</p>	<p>2006-12-16 17:40:49</p>	

Name	Patrol Visualis	
URL	http://www.bmc.com	
Description	Brief description: A SNMP-based network management tool that provides layer 2 and layer 3 discovery and mapping. Detailed description:	
Context		
Main Functionalities	<ul style="list-style-type: none"> Automated Layout Graph Manipulation Graph Viewing Network management/discovery 	Comments:
Domain	<ul style="list-style-type: none"> Computer Networks 	Comments:
	User Role:	Activity: <ul style="list-style-type: none"> Monitor
Network Representation		
Dimensionality	<ul style="list-style-type: none"> 2D 3D Temporal 	Comments: The user can playback the behaviour of the system during any selected time period.
Deployment		
	Type: <ul style="list-style-type: none"> Standalone Tool 	OS:
	Hardware:	Users:
		Availability: <ul style="list-style-type: none"> Unsupported
Last Modified		
	2006-12-16 17:41:06	

Name	PingTV	
Description	Brief description: A visual network monitor Detailed description: From Abstract: PingTV is used at Illinois State University as a visualization tool to communicate real-	

	time network conditions to the university community via a dedicated channel on the campus cable TV system. Colored symbols allow students and staff to discern high-congestion “rush hours” and understand why their specific Internet connectivity is “broken” from the wide range of potential causes
--	---

Context	
----------------	--

<u>Main Functionalities</u>	<ul style="list-style-type: none"> Automated Layout Graph Manipulation Graph Viewing Network management/discovery 	Comments:
-----------------------------	---	------------------

<u>Domain</u>	<ul style="list-style-type: none"> Computer Networks 	Comments:
---------------	---	------------------

	<u>User Role:</u>	<u>Activity:</u> <ul style="list-style-type: none"> Monitor
--	-------------------	--

Network Representation	
-------------------------------	--

<u>Links</u>	<ul style="list-style-type: none"> Coloured 	Comments:
--------------	--	------------------

<u>Nodes</u>	<ul style="list-style-type: none"> Coloured Symbol
--------------	--

<u>Dimensionality</u>	<ul style="list-style-type: none"> 2D Geospatial 	Comments:
-----------------------	--	------------------

User Interaction	
-------------------------	--

<u>User Interaction</u>	<ul style="list-style-type: none"> GUI 	Comments:
-------------------------	---	------------------

Deployment	
-------------------	--

	<u>Type:</u> <ul style="list-style-type: none"> Standalone Tool 	<u>OS:</u>
--	--	------------

	<u>Hardware:</u>	<u>Users:</u> <ul style="list-style-type: none"> Multiple Networked 	<u>Availability:</u> <ul style="list-style-type: none"> In-house Use Research Prototype
--	------------------	---	---

References	
-------------------	--

<u>References</u>	See papers: LCN01PingTV.pdf - "Network Management Visualization With PingTV" 00964541.pdf - "PingTV: A Case Study in Visual Network Monitoring"
-------------------	---

Last Modified	2006-12-17 18:29:58
----------------------	---------------------

Name	PlotPaths
-------------	------------------

URL	http://www.caida.org/tools/visualization/plotpaths/	
Description	<p>Brief description: PlotPaths plots paths collected from a single source host to one or more destinations.</p> <p>Detailed description: It shows the connections between intermediate nodes along each path, while preserving higher order groupings.</p>	
Context		
Main Functionalities	<ul style="list-style-type: none"> Automated Layout Graph Manipulation Graph Viewing 	Comments:
Domain	<ul style="list-style-type: none"> Any 	Comments:
Network Representation		
Type	<ul style="list-style-type: none"> Undirected 	
Links	<ul style="list-style-type: none"> User Defined 	Comments: Any JAVA data type can be used for link/node attributes
Nodes	<ul style="list-style-type: none"> User Defined 	
Dimensionality	<ul style="list-style-type: none"> 2D 	Comments:
Deployment		
	<p>Type:</p> <ul style="list-style-type: none"> Open Source Standalone Tool 	<p>OS:</p> <ul style="list-style-type: none"> Multi-Platform (JAVA)
Extensibility	<ul style="list-style-type: none"> JAVA 	Comments:
	Hardware:	<p>Users:</p> <p>Availability:</p> <ul style="list-style-type: none"> Freeware
Cost	Free	Comments:
Last Modified		
	2006-12-15 20:36:46	

Name	PPCGraph
URL	http://www.cs.usyd.edu.au/~carsten/ppgraph/
Description	<p>Brief description: PPCGraph is a simple graph editor for MS Pocket PC 2002</p>

	Detailed description:	
Context		
<u>Main Functionalities</u>	<ul style="list-style-type: none"> Automated Layout Graph Manipulation Graph Viewing 	Comments:
<u>Domain</u>	<ul style="list-style-type: none"> Any 	Comments:
Network Representation		
<u>Links</u>	<ul style="list-style-type: none"> Coloured 	Comments:
<u>Nodes</u>	<ul style="list-style-type: none"> Coloured Labelled 	
<u>Layout Algorithms</u>	<ul style="list-style-type: none"> Spring 	Comments:
<u>Dimensionality</u>	<ul style="list-style-type: none"> 2D 	Comments:
User Interaction		
<u>User Interaction</u>	<ul style="list-style-type: none"> Add/Delete GUI Reposition Select Sensory:Touch 	Comments: The stylus is used to create the graph.
Deployment		
	<u>Type:</u> <ul style="list-style-type: none"> Standalone Tool 	<u>OS:</u> <ul style="list-style-type: none"> PocketPC 2002
<u>Interoperability</u>	Graphs can be saved and loaded in GML format.	
	<u>Hardware:</u>	<u>Users:</u> <ul style="list-style-type: none"> Single
		<u>Availability:</u> <ul style="list-style-type: none"> Freeware
<u>Cost</u>	Free	Comments:

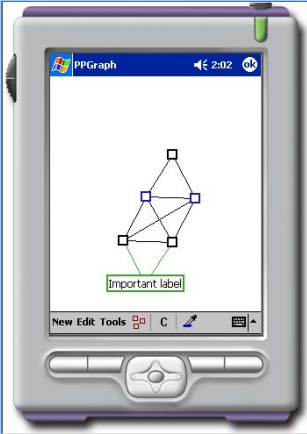
<p>Images</p>	
<p>Last Modified</p>	<p>2006-12-18 19:25:50</p>

<p>Name</p>	<p>prefuse</p>
<p>URL</p>	<p>http://prefuse.sourceforge.net/</p>
<p>Description</p>	<p>Brief description: Prefuse is a JAVA toolkit which contains features for data modeling, visualization, and interaction.</p> <p>Detailed description: Prefuse is an extensible software framework for helping software developers create interactive information visualization applications using the Java programming language. It can be used to build standalone applications, visual components embedded in larger applications, and web applets. Prefuse intends to greatly simplify the processes of representing and efficiently handling data, mapping data to visual representations (e.g., through spatial position, size, shape, color, etc), and interacting with the data. Some of the features of prefuse include:</p> <ul style="list-style-type: none"> • Table, Graph, and Tree data structures supporting arbitrary data attributes, data indexing, and selection queries, all with an efficient memory footprint. • Components for layout, color, size, and shape encodings, distortion techniques, animation, and more. • A library of interaction controls for common interactive, direct-manipulation operations. • Animation support through a general activity scheduling mechanism. • View transformations supporting panning and zooming, including both eometric and semantic zooming. • Dynamic queries for interactive filtering of data. • Integrated text search using a number of available search engines. • A physical force simulation engine for dynamic layout and animation. • Flexibility for multiple views, including "overview+detail" and "small multiples" displays. • A built in, SQL-like expression language for writing queries to prefuse data structures and creating derived data fields. • Support for issuing queries to SQL databases and mapping query results into prefuse data structures. • Simple, developer-friendly APIs for creating custom processing, interaction, and rendering components.

Product Version/Status	beta (release 2006.07.15)	
Context		
Main Functionalities	<ul style="list-style-type: none"> Automated Layout Graph Manipulation Graph Viewing 	Comments:
Domain	<ul style="list-style-type: none"> Any 	Comments:
Network Representation		
Layout Algorithms	<ul style="list-style-type: none"> Balloon Tree Circular Force-Directed Grid Radial Tree Random Spring Spring FR Squarified Tree 	Comments:
Dimensionality	<ul style="list-style-type: none"> 2D 	Comments:
User Interaction		
User Interaction	<ul style="list-style-type: none"> Add/Delete Drag & Drop GUI Pan Reposition Rotate Zoom 	<p>Comments:</p> <p>Interactive views are provided by the Display component, which acts as a camera onto the contents of a Visualization. The Display draws all the items within its current view, and can be panned, zoomed, and rotated as desired. A single Visualization can be associated with multiple Display instances, enabling different multi-view configurations, including overview + detail views and small multiples displays. Display instances are first-class user interface components, and can be added into Java applications and applets.</p> <p>Each Display also supports any number of interactive Controls, which process mouse or keyboard actions on the Display and on individual VisuallItems. The prefuse.controls package provides pre-built controls for selecting focus items, dragging items around, and panning, zooming, and rotating the Display view. Furthermore, it is easy to create custom Controls by subclassing the ControlAdapter class.</p>
Deployment		

	<p>Type:</p> <ul style="list-style-type: none"> • Components for tool building • Open Source <p>OS:</p> <ul style="list-style-type: none"> • Multi-Platform (JAVA) 	
OS Comments/Dependencies	Prefuse requires the Java Development Kit (JDK), version 1.4.2 or higher	
Extensibility	<ul style="list-style-type: none"> • JAVA 	Comments:
Interoperability	Import/Export formats GraphML TreeML CSV	
	Hardware:	Users: Availability: <ul style="list-style-type: none"> • Freeware • In Development
Cost	Free	Comments: Prefuse is released under the terms of a BSD (Berkeley Standard Distribution) license.

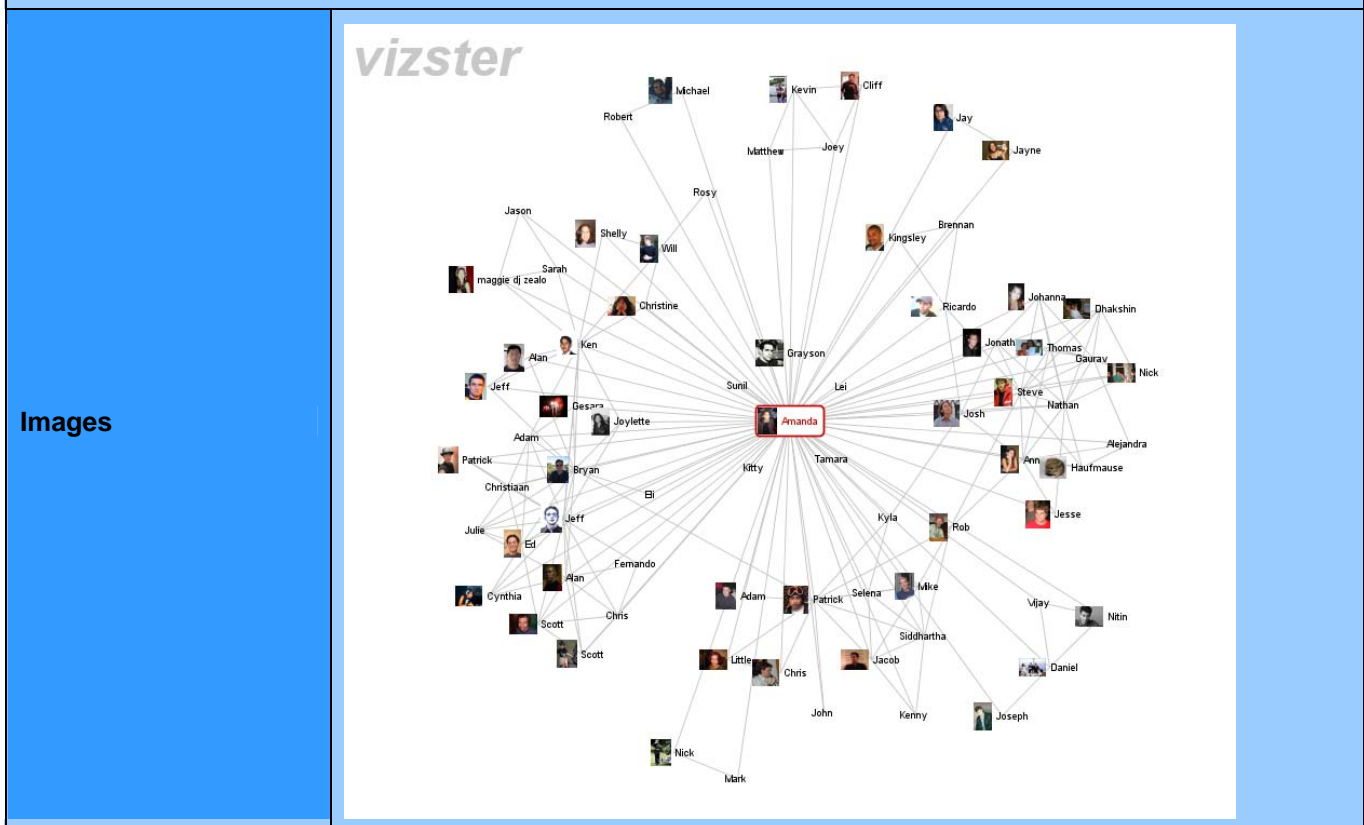

Last Modified	2006-12-18 19:26:28
----------------------	---------------------

Name	PyGraphvis	
URL	https://networkx.lanl.gov/wiki/pygraphviz	
Description	<p>Brief description: Pygraphviz is a Python interface to the Graphviz graph layout and visualization package.</p> <p>Detailed description: With Pygraphviz you can create, edit, read, write, and draw graphs using Python to access the Graphviz graph data structure and layout algorithms.</p>	
Product Version/Status	0.33 (2006-11-20 09:37)	
Context		
Main Functionalities	<ul style="list-style-type: none"> • Automated Layout • Graph Manipulation • Graph Viewing 	Comments:
Network Representation		
Type	<ul style="list-style-type: none"> • Directed • Undirected 	
Layout Algorithms	<ul style="list-style-type: none"> • Circular • Hierarchical • Random • Spring • Spring FR • Spring KK 	Comments:
Dimensionality		Comments:
Deployment		
	<p>Type:</p> <ul style="list-style-type: none"> • Components for tool building • Open Source 	<p>OS:</p> <ul style="list-style-type: none"> • Linux • UNIX
OS Comments/Dependencies	<p>Dependencies</p> <p>* Python version 2.3 or later http://www.python.org/</p> <p>* Graphviz http://graphviz.org/</p>	
Extensibility	<ul style="list-style-type: none"> • Python 	Comments:
Scalability	<p>Max Nodes: Unlimited</p> <p>Max Links: Unlimited</p>	Comments:

	<u>Hardware:</u>	<u>Users:</u>	<u>Availability:</u> • Freeware
<u>Cost</u>	Free	Comments: Pygraphviz is distributed with a BSD license.	
Last Modified	2006-12-10 16:39:16		

Name	SemaSpace		
URL	http://residence.aec.at/didi/FLweb/		
Description	<p>Brief description: SemaSpace is a fast and easy to use graph editor for large knowledge networks, specially designed for the application in non technical sciences and the arts.</p> <p>Detailed description: Abstract</p> <p>SemaSpace is a fast and easy to use graph editor for large knowledge networks, specially designed for the application in non technical sciences and the arts. It creates interactive graph layouts in 2d and 3d by means of a flexible algorithm. The system is powerful enough for the calculation of complex networks and can incorporate additional data such as images, sounds and full texts.</p>		
Product Version/Status			
Context			
Main Functionalities	<ul style="list-style-type: none"> Automated Layout Graph Manipulation Graph Viewing 	Comments:	
Domain	<ul style="list-style-type: none"> Any 	Comments:	
Network Representation			
Type	<ul style="list-style-type: none"> Semantic 		
Links		Comments:	
Nodes	<ul style="list-style-type: none"> User Defined 		
Layout Algorithms		Comments: The layout algorithm does not rely on typical spring embedders, since they tend to become unstable in graphs with high edge counts. Instead, a fixed length is calculated for each edge based on the valence of the connected vertices, which is consequently applied with damping. Additionally, radial global forces contribute to a	

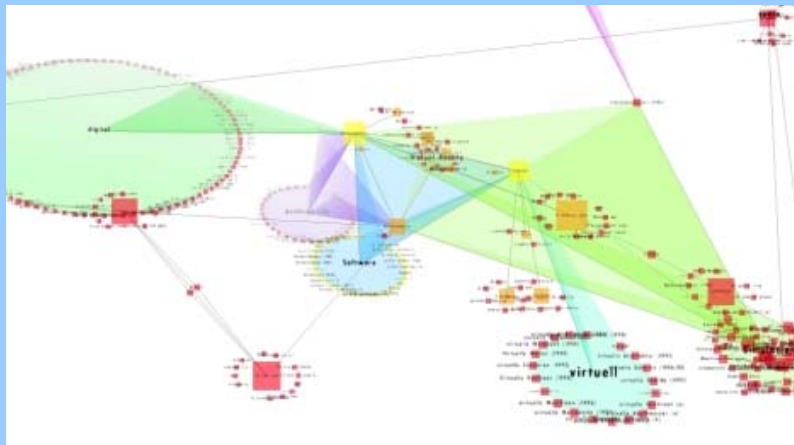
		well ordered, untangled graph layout.
User Interaction		
<u>User Interaction</u>	<ul style="list-style-type: none"> • Pan • Zoom 	Comments:
Deployment		
	<u>Type:</u> <ul style="list-style-type: none"> • Web-based 	<u>OS:</u>
<u>OS Comments/ Dependencies</u>	Virtools plugin http://www.virtools.com/downloads/player/install.asp	
<u>Scalability</u>	Max Nodes: Unknown Max Links: 1001-10,000	Comments:
	<u>Hardware:</u>	<u>Users:</u> <u>Availability:</u> <ul style="list-style-type: none"> • Research Prototype
Images		
		
Last Modified	2006-12-10 16:39:16	

Name	SHriMP
URL	http://www.thechiselgroup.org/shrimp
Description	Brief description: SHriMP (Simple Hierarchical Multi-Perspective) is a domain-independent visualization technique designed to enhance how people browse and explore complex information spaces.

	Detailed description:	
Context		
<u>Main Functionalities</u>	<ul style="list-style-type: none"> Automated Layout Graph Manipulation Graph Viewing 	Comments:
<u>Domain</u>	<ul style="list-style-type: none"> Any 	Comments:
Network Representation		
<u>Links</u>		Comments:
<u>Nodes</u>	<ul style="list-style-type: none"> Labelled 	
<u>Layout Algorithms</u>	<ul style="list-style-type: none"> Grid Radial Spring Tree TreeMap 	Comments:
User Interaction		
<u>User Interaction</u>	<ul style="list-style-type: none"> Filter GUI Pan Search Zoom 	Comments:
Deployment		
	<u>Type:</u> <ul style="list-style-type: none"> Standalone Tool Web-based 	<u>OS:</u> <ul style="list-style-type: none"> Multi-Platform (JAVA)
<u>Extensibility</u>	<ul style="list-style-type: none"> Javascript 	Comments: Scripting via the Bean Scripting Framework (BSF).
	<u>Hardware:</u>	<u>Users:</u> <ul style="list-style-type: none"> Research Prototype

Images

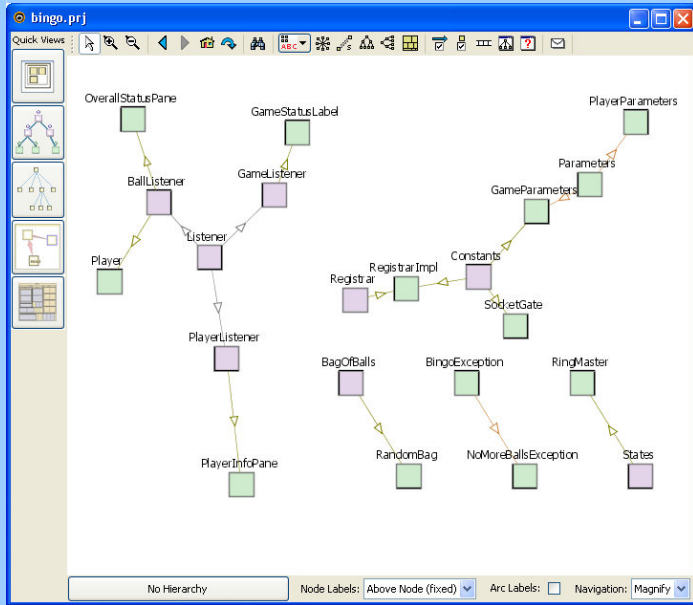
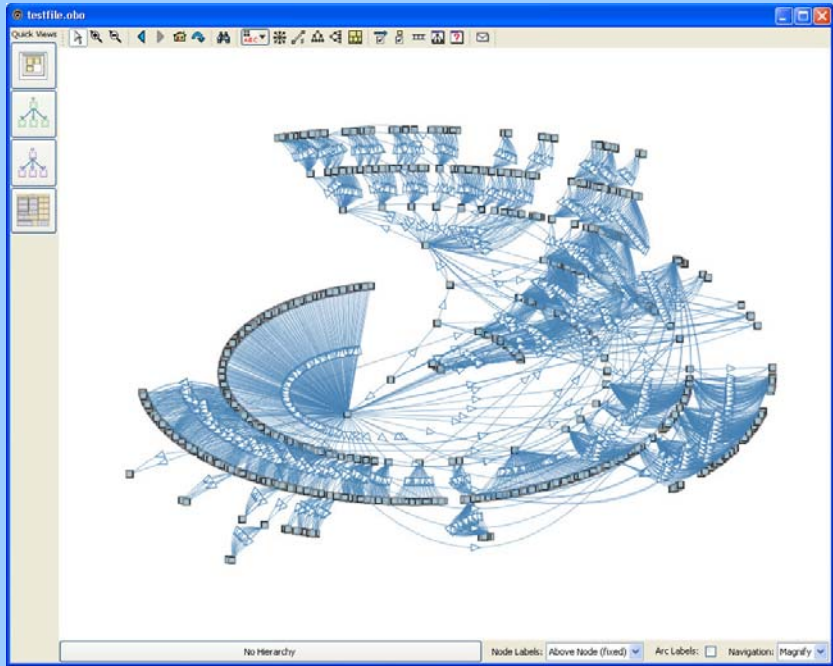

Last Modified	2006-12-10 16:39:16

Name	SIMG	
URL	http://simg.cs.arizona.edu/	
Description	<p>Brief description: Simultaneous Graph Drawing: Layout Algorithms and Visualization Schemes.</p> <p>Detailed description: This research project attempts to solve the problem of drawing and display a series of graphs that share part or all of the same vertex set.</p> <p>Abstract from associated paper: In this paper we consider the problem of drawing and displaying a series of related graphs, i.e., graphs that share all, or parts of the same vertex set. We designed and implemented three different algorithms for simultaneous graphs drawing and three different visualization schemes. The algorithms are based on a modification of the force-directed algorithm that allows us to take into account vertex weights and edge weights in order to achieve mental map preservation while obtaining individually readable drawings.</p>	
Context		
Main Functionalities	<ul style="list-style-type: none"> Automated Layout Graph Viewing 	Comments:
Domain	<ul style="list-style-type: none"> Any 	Comments:
Network Representation		
Links	<ul style="list-style-type: none"> Coloured Labelled 	Comments:

	<ul style="list-style-type: none"> • Weighted 	
<p><u>Nodes</u></p>	<ul style="list-style-type: none"> • Coloured • Labelled • Weighted 	
<p><u>Layout Algorithms</u></p>	<ul style="list-style-type: none"> • Force-Directed 	<p>Comments: The layout algorithms are all based on a force-directed approach. These layout algorithms are specifically designed such that the individual layout for each graph is clear while providing some sort of relationship between all the layouts as to create a mental map between the different relationships represented by each graph.</p> <p>Aggregate Layout: The Aggregate Layout Algorithm creates an aggregate graph which contains one vertex that represents all corresponding vertices from all the graphs. Consequently, each vertex in the aggregate graph represents one or more vertices from the graph sequence, depending on how many graphs that vertex shows up in. The edge set of the aggregate graph is the union of all the edge sets for the graph series. Consequently, there may exist multiple edges from one vertex to another. The aggregate graph is node-weighted and edge-weighted, where the node weight corresponds to the number of times a particular vertex appears in the sequence, and the edge weight corresponds to the number of times a particular edge appears in the sequence. A modified force-directed approach is then used to layout the aggregate graph, taking into account the weights of the nodes and the edges.</p> <p>Merged Layout: Much like the Aggregate Layout Algorithm, the Merged Layout Algorithm creates a large graph, called a merged graph, and uses a modified force-directed approach to layout the series of graphs. But unlike the aggregate graph created by the Aggregate Layout Algorithm, the merged graph contains a unique vertex for every single vertex that appears in the series. In other words, the number of vertices in the merged graph is the sum of the number of vertices from each graph in the graph series. The edge set of the merged graph also contains all of the edges in the series of graphs. Since every vertex is unique, every edge is also unique. The merged graph's edge set also has a new set of edges. These edges connect corresponding vertices between graphs. The Merged Layout algorithm and implementation allows the user to choose the edge weight of this new set of edges. The larger the weight of these edges the closer the corresponding vertices in each separate layout will be. The final layout of the graphs will put corresponding vertices from each graph relatively close to each other, but unlike the Aggregate Layout Algorithm, they will not have the exact same position</p> <p>Converging Iterations Layout: The final layout method, the Converging Iterations Layout Algorithm, is quite different than the other two methods. While this algorithm would work for any number of graphs, our implementation works for two graphs but it can be extended to handle more graphs. Unlike the Aggregate Layout Algorithm and the Merged Layout Algorithm, this algorithm does not create a global graph and extract individual layout of each graph from the global layout. Instead this algorithm, first computes initial good placement of both graphs, which we will call G1 and G2, using intelligent placement of vertices,</p>

		based on the graph distance. Then the algorithm uses the placement for G1, as the initial placement for G2. Similarly, G2's good placement is used as initial placement for G1. Now we use force-directed placement on each graph and obtain our new good placement of each graph. Then we repeat the process until the graphs converge to a some desirable minimum distance.
Dimensionality	<ul style="list-style-type: none"> • 2D • 3D 	Comments:
Visual Enhancements		
Visual Enhancements	<ul style="list-style-type: none"> • Animation/ Video 	<p>Comments: Three different techniques for viewing multiple graphs are implemented. Each visualization scheme attempts to illustrate the series of graphs in such a way to preserve both the individual mental map for each graph and the mental map between all the graph layouts. Each visualization technique corresponds closely with a layout algorithm, but any combination of a layout algorithm and a visualization scheme can be used.</p> <p>Aggregate View: Using the aggregate view model, each vertex is displayed only once, even though it may appear in multiple graphs. The edges from all the graphs in the sequence are drawn. We use different edge colors and edge styles to differentiate between the different graphs. Displaying all graphs using a single vertex set allows the viewer to see multiple graphs at the same time and view the difference in relationships more easily. This visualization technique corresponds very closely to the Aggregate Layout Algorithm because that algorithm gives corresponding vertices from different graphs the same exact location.</p> <p>3D View: In this visualization scheme each of the graphs is drawn on its separate 2D plane, and the planes are layered in 3D in the order of appearance. By focusing on a single plane, the viewer can easily visualize each individual graph. If the vertices from each graph have relatively close proximity or the same location to corresponding vertices in the other graphs, this visualization scheme illustrates a mental map between all the different graphs. This property makes this visualization technique correspond closely to the Merged Layout Algorithm.</p> <p>Split View: This visualization scheme corresponds to the Converging Iterations Layout Algorithm. Using the split view model, the two graphs are drawn separately in their own windows in 2-dimensions and both windows are on the same screen. The view model can be generalized to handle many graphs, in which case the screen would be split into many individual panes. While there can be any number of graphs displayed in such a way, as the number of graphs being visualized increases, the user's ability to read the relation between them greatly decreases.</p>
Deployment		
	<p>Type:</p> <ul style="list-style-type: none"> • Standalone Tool 	<p>OS:</p> <ul style="list-style-type: none"> • Multi-Platform (JAVA)
OS Comments/	The program is written in Java and was tested using Java Runtime 1.4.	

<u>Dependencies</u>	The 3D rendering requires Java3D and either an implementation of DirectX or OpenGL.
<u>Hardware:</u>	<u>Users:</u>
<u>Availability:</u>	<ul style="list-style-type: none"> • Research Prototype



Images

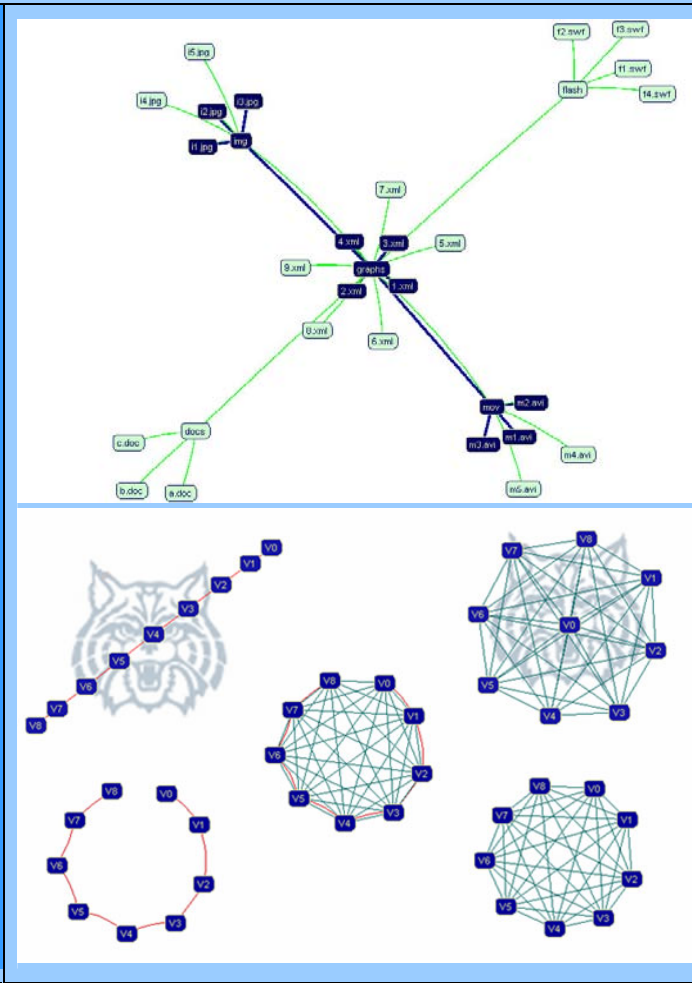

Last Modified	2006-12-10 16:39:16

Name	SNMPC
URL	http://www.castlerock.com/products/SNMPC/default.php
Description	<p>Brief description: Visualize, monitor, and manage your network</p> <p>Detailed description:</p>
Product Version/Status	7

Context

Main Functionalities	<ul style="list-style-type: none"> Automated Layout Graph Manipulation Graph Viewing Network management/discovery 	Comments:
Domain	<ul style="list-style-type: none"> Computer Networks 	Comments:
	<p>User Role:</p>	<p>Activity:</p> <ul style="list-style-type: none"> Monitor Track

Network Representation

Links	<ul style="list-style-type: none"> Labelled Pre-Defined Attributes (see comments) 	<p>Comments: Attributes:</p> <ul style="list-style-type: none"> - Background Shape: Icon background, one of -Square, Circle, Hexagon, Octagon, or Diamond. - Bitmap: Background bitmap image. - Bitmap Scale: Background bitmap image scaling factor (bigger number expands).
Nodes	<ul style="list-style-type: none"> Labelled Pre-Defined Attributes (see comments) 	

	<ul style="list-style-type: none"> • Symbol 	<p>Show Link Name: Link names normally hidden.</p> <ul style="list-style-type: none"> - Exec Program: Double-click program for devices. Include any of the following special program arguments: \$a – IP Address, \$n – node name, \$g – Read Community; \$s – Set community, \$w – console window number. - Poll Interval: Seconds between poll sequences. - Poll Timeout: Seconds to wait for a response after a poll is sent. - Poll Retries: Number of times to retry a failed poll during a single poll sequence. - Polling Agent: IP Address of the Polling Agent system that performs regular and trend statistics polling for this object. Unless you are using Remote Polling Agents, this is set to localhost. - TCP Services: List of TCP service names to poll. - Status Variable: An SNMP variable with instance that is polled to determine device status (as opposed to just polling for device response). For example, ifOperStatus.3. - Status Value: The number to be compared to the returned Status Variable value. - Status OK Expr: The expression to use when comparing the Status Value to the returned Status Variable to determine if the status is OK (<, >, <=, >=, =, !=). <p>HasRMON: Set to TRUE to enable the RMON tool.</p> <ul style="list-style-type: none"> - MAC Address: Primary device MAC address or link MAC address, if known. - SNMP ObjectID: Read-Only. The System Object Identifier of an SNMP object.
Layout Algorithms	<ul style="list-style-type: none"> • Bus • Circular • Tree 	<p>Comments: SNMPC supports a multi-level hierarchical map. Each hierarchy can represent cities, buildings, or subnetworks. Imported bitmaps of geographic maps or floor plans, along with manual or automatic network placement, lets you create a layout that closely matches the actual network</p>
Dimensionality	<ul style="list-style-type: none"> • 2D 	<p>Comments:</p>
Analysis		
General Analysis	<ul style="list-style-type: none"> • Trend Analysis 	<p>Comments:</p>
Visual Abstraction	<ul style="list-style-type: none"> • Chart:Bar • Chart:Line • Chart:Pie 	<p>Comments: SNMPC Enterprise automatically generates scheduled daily, weekly, and monthly statistic reports. Report formats include graph, bar chart, distribution, and summary.</p>
User Interaction		
User Interaction	<ul style="list-style-type: none"> • Add/Delete • Cut & Paste • Drag & Drop • Drill down • GUI 	<p>Comments:</p>

	<ul style="list-style-type: none"> • Pan • Reposition • Zoom 	
--	---	--

Deployment

	<p>Type:</p> <ul style="list-style-type: none"> • Standalone Tool 	<p>OS:</p> <ul style="list-style-type: none"> • Windows • Windows 2000 • Windows 95/98/ME • Windows NT • Windows XP
--	---	---

Extensibility	<ul style="list-style-type: none"> • C • C++ 	<p>Comments: A number of APIs are provided to allow customization.</p>
----------------------	--	---

Interoperability	A DDE interface is provided so that external programs can query the map, MIB database, and execute SNMP commands.	
-------------------------	---	--

	<p>Hardware:</p>	<p>Users:</p>	<p>Availability:</p> <ul style="list-style-type: none"> • Commercially Available
--	-------------------------	----------------------	--

Cost	\$1001 - \$5000	<p>Comments: http://www.castlerock.com/how_to_buy/default.htm</p>
-------------	-----------------	---

Images

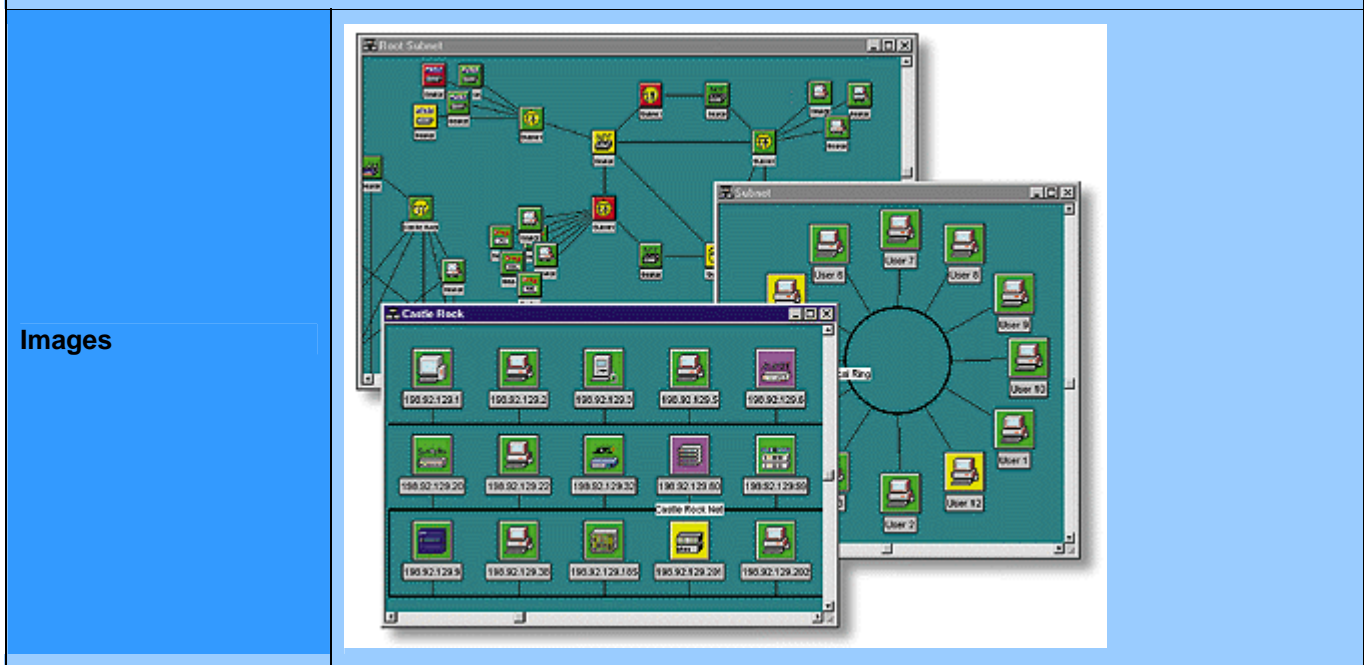

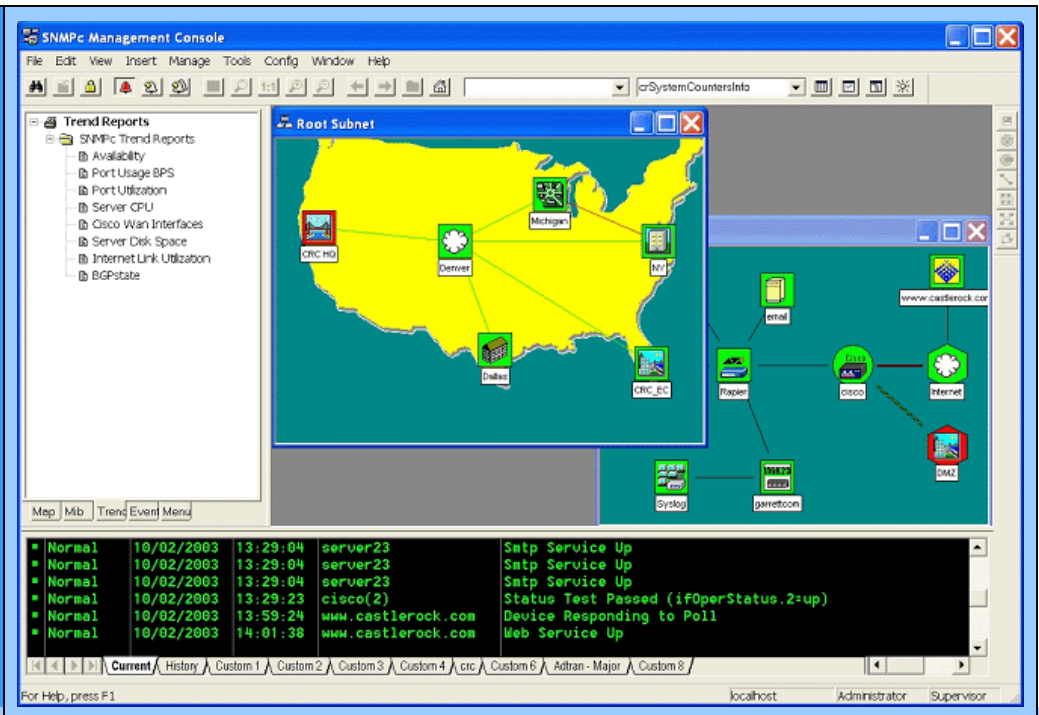
	 <p>The screenshot displays the SNMPc Management Console interface. On the left, there is a 'Trend Reports' sidebar with categories like Availability, Port Usage, and Server CPU. The main area shows a network map titled 'Root Subnet' with nodes for various locations (CNC_HQ, Denver, Michigan, etc.) and services (server23, www.castlerock.com). A log window at the bottom shows system status messages such as 'Satp Service Up' and 'Web Service Up'.</p>
Last Modified	2006-12-18 19:27:34

Name	Social Networks Visualiser	
URL	http://socnetv.sourceforge.net/	
Description	<p>Brief description: Social Networks Visualiser (SocNetV) is a Linux GPL program designed to allow people draw, visualise and layout social networks.</p> <p>Detailed description:</p>	
Product Version/Status	0.42	
Context		
Main Functionalities	<ul style="list-style-type: none"> Automated Layout Graph Viewing Network Analysis 	Comments:
Domain	<ul style="list-style-type: none"> Social Networks 	Comments:
Network Representation		
Layout Algorithms	<ul style="list-style-type: none"> Circular 	Comments:
Analysis		
Network Analysis	<ul style="list-style-type: none"> Centrality:Betweenness Centrality:Closeness Centrality:Degree 	Comments:

	<ul style="list-style-type: none"> Centrality:Graph Centrality:Stress 	
Deployment		
	Type: <ul style="list-style-type: none"> Open Source Standalone Tool 	OS: <ul style="list-style-type: none"> Linux
Extensibility	<ul style="list-style-type: none"> C++ 	Comments:
Interoperability	SocNetV can read and write various network file formats, such as PAJEK, sociomatrix and dot. SocNetV can also export image formats such as BMP and PNG files.	
Cost	Free	Comments:
Last Modified		
2006-12-15 20:43:41		

Name	SoNIA (Social Network Image Animator)	
URL	http://www.stanford.edu/group/sonia/	
Description	<p>Brief description: SoNIA is a Java-based package for visualizing dynamic or longitudinal "network" data.</p> <p>Detailed description: SoNIA (Social Network Image Animator) is a java package for making animations of dynamic networks. Networks in SoNIA are not limited to the standard notion of a set of relations among a set of entities at a given point in time. Instead, consider the entities (or nodes and individuals) as a stream of events. Every event has a real-valued time coordinate indicating when it occurs. If the event is not instantaneous, it also has an ending coordinate to indicate its duration. A node-event, for example, can describe a company that comes into existence on Jan 1, 1990 and then dissolves on June 1, 1996. Alternatively, a node event might describe a single observation of a node, such as an individual in a friendship survey wave done in 1995.</p>	
Product Version/Status	1.1.2 06-01-19	
Context		
Main Functionalities	<ul style="list-style-type: none"> Automated Layout Graph Viewing 	Comments:
Domain	<ul style="list-style-type: none"> Social Networks 	Comments:
Network Representation		
Layout Algorithms	<ul style="list-style-type: none"> Circular 	Comments:

	<ul style="list-style-type: none"> • MDS:Metric (SVD) • Moody's Peer Influence • Spring FR • Spring KK 	
Dimensionality	<ul style="list-style-type: none"> • 2D • Temporal 	Comments: SoNIA was specifically designed for visuallizing networks that change over time.
Analysis		
General Analysis	<ul style="list-style-type: none"> • Shepard's Stress Plot 	Comments:
Visual Enhancements		
Visual Enhancements	<ul style="list-style-type: none"> • Animation/Video 	Comments:
User Interaction		
User Interaction	<ul style="list-style-type: none"> • GUI 	Comments:
Deployment		
	<p>Type:</p> <ul style="list-style-type: none"> • Open Source - GPL • Standalone Tool 	<p>OS:</p> <ul style="list-style-type: none"> • Linux • Mac OS X • Multi-Platform (JAVA) • Windows
Extensibility	<ul style="list-style-type: none"> • JAVA 	Comments:
Interoperability	<p>.net file format: The .net parser is for constructing networks from text files in Pajek's *.net Arc/Edge list file format. Will not read Pajek Arclist/Edgelist format, or Pajek matrix format. Requires that if "**Arcs" and "**Edges" both exist in file, "**Arcs" must be before "**Edges" (this is Pajek's default).</p> <p>The .son File Format: The .son format is intended to deal with some of the limitations of the .net format, and facilitate storing and importing network event, attribute rich, data. In addition, it is set up to be as easy as possible to write export scripts from other applications or modify spreadsheet data. The underlying concept is that of an arc-list format (as opposed to a matrix format) with separate sections for node and arc records. The entries for each record are tab-delimited, and are order-insensitive because they are defined by column headings rather than inline tags. However, most of the attributes are optional and can be omitted, and the order of the columns is not important. The required attributes are some kind of unique identifying tag, and time coordinates for the event. This makes the format pretty flexible.</p> <p>Network animations are saved as quicktime movies</p>	
	Hardware:	<p>Users:</p> <p>Availability:</p> <ul style="list-style-type: none"> • Freeware • In Development

<u>Cost</u>	Free	Comments: Subject to the GNU GPL license.
Last Modified	2006-12-18 19:44:08	

Name	Sourcefire	
URL	http://www.sourcefire.com/products.html	
Description	<p>Brief description: Sourcefire is a network defense system that provides network discovery, intrusion management, vulnerability management, and network monitoring technologies.</p> <p>Detailed description: Sourcefire's approach can be broken down into three key concepts: Discover, Determine, Defend.</p> <p>Discover: The Sourcefire system consists of different types of sensors (hardware appliances): Sourcefire intrusion sensors and Sourcefire RNA sensors. The intrusion sensors are build upon the open-source SNORT rules based detection enging to provide a combination of signature, protocol, and anomaly-based inspection methods to achieve its attack detection and prevention capability. Using a combination of passive network discovery, behavioral profiling and integrated vulnerability management technologies, Sourcefire RNA (Real-time Network Awareness) Sensors provide a comprehensive view of security events, and the basis for effective network defense.</p> <p>Determine: By closely integrating and correlating the threat information provided by Sourcefire Intrusion Sensors and Agents with the network intelligence provided by Sourcefire RNA Sensors, the Sourcefire Defense Center prioritizes the millions of security events to determine the most critical events to an organization's business, and takes the appropriate actions.</p> <p>Defend: Send alerts through email, SNMP, Syslog, and trouble ticket systems. Block attacks through firewalls, IPSs, switches, and routers. Correct the situation through patch or configuration management</p>	

Context		
----------------	--	--

<u>Main Functionalities</u>	<ul style="list-style-type: none"> • Automated Layout • Graph Manipulation • Graph Viewing • Network managment/discovery • Network Security/IDS 	Comments:
<u>Domain</u>	<ul style="list-style-type: none"> • Computer Networks 	Comments:

	<p><u>User Role:</u></p>	<p><u>Activity:</u></p> <ul style="list-style-type: none"> • Investigate • Monitor • Track
Network Representation		
<p><u>Layout Algorithms</u></p>		<p>Comments: The Sourcefire Real-time Network Awareness Visualizer (RNA Visualizer) is a client-side application that generates a three-dimensional (3D) model of your network architecture based on accumulated RNA data. In addition, when connected to a Sourcefire Defense Center, it can provide real-time notification for network change, IDS impacts, and policy violations.</p>
<p><u>Dimensionality</u></p>	<ul style="list-style-type: none"> • 3D 	<p>Comments:</p>
User Interaction		
<p><u>User Interaction</u></p>	<ul style="list-style-type: none"> • GUI • Web/CGI 	<p>Comments: The primary RNA interface is the browser-based display. It is through this facility that the heavy lifting of analysis, configuration, administration, and reporting is performed.</p>
Deployment		
	<p><u>Type:</u></p> <ul style="list-style-type: none"> • Standalone Tool • Web-based 	<p><u>OS:</u></p> <ul style="list-style-type: none"> • Hardware Appliance
<p><u>OS Comments/Dependencies</u></p>	<p>Each appliance includes hardware, software, operating system and database pre-installed.</p>	
<p><u>Interoperability</u></p>	<p>Standard or customized reports can be generated in HTML, PDF or CSV formats.</p>	
	<p><u>Hardware:</u></p>	<p><u>Users:</u></p> <ul style="list-style-type: none"> • Multiple • Networked
		<p><u>Availability:</u></p> <ul style="list-style-type: none"> • Commercially Available

Images		
	Last Modified	2006-12-18 19:27:53

Name	SpaceTree	
URL	http://www.cs.umd.edu/hcil/spacetree/	
Description	<p>Brief description: SpaceTree is a novel tree browser that builds on the conventional layout node link diagrams along a single preferred direction.</p> <p>Detailed description:</p>	
Context		
Main Functionalities	<ul style="list-style-type: none"> Automated Layout Graph Viewing 	Comments:
Domain	<ul style="list-style-type: none"> Any 	Comments:
Network Representation		
Links	Comments:	
Nodes	<ul style="list-style-type: none"> Labelled 	Comments:
Layout Algorithms	<ul style="list-style-type: none"> Tree 	Comments:

Dimensionality	<ul style="list-style-type: none"> • 2D 	Comments:
Deployment		
	Type: <ul style="list-style-type: none"> • Standalone Tool 	OS:
Cost	Free - For noncommercial use	Comments:
Images		
Last Modified	2006-12-10 16:39:16	

Name	SpatialFX	
URL	http://www.objectfx.com/products/spatialfx.asp	
Description	<p>Brief description: SpatialFX visually presents information in user-defined ways.</p> <p>Detailed description: Provides Map Display and Interaction, Geocoding, Reverse Geocoding and Routing. Provides integrated views of multiple, disparate data sources. This allows users to “drill down” and access information by clicking on one or more spatial objects.</p>	
Context		
Main Functionalities	<ul style="list-style-type: none"> • Automated Layout • Graph Manipulation • Graph Viewing 	Comments:
Domain	<ul style="list-style-type: none"> • Any 	Comments:
Network Representation		
Links	<ul style="list-style-type: none"> • User Defined 	Comments:

<u>Nodes</u>	<ul style="list-style-type: none"> User Defined 	Any JAVA data type can be used for link/node attributes
<u>Dimensionality</u>	<ul style="list-style-type: none"> 2D 3D Geospatial 	Comments:
Visual Enhancements		
<u>Visual Enhancements</u>	<ul style="list-style-type: none"> Overlay 	Comments:
User Interaction		
<u>User Interaction</u>	<ul style="list-style-type: none"> Drill down GUI Web/CGI 	Comments: The SpatialFX Web Application Framework is a highly configurable web presentation layer that works on top of the SpatialFX Server. The framework makes use of JSP technology.
Deployment		
	<u>Type:</u> <ul style="list-style-type: none"> Standalone Tool Web-based 	<u>OS:</u> <ul style="list-style-type: none"> Linux Multi-Platform (JAVA) UNIX Windows
<u>OS Comments/Dependencies</u>	Java 3D 1.3 API (for 3D option)	
<u>Extensibility</u>	<ul style="list-style-type: none"> JAVA JSP 	Comments: JavaBeans and applets Provides an API backed up by hundreds of Java classes and thousands of methods available to programmers.
<u>Interoperability</u>	Handling external and government data formats, standardized symbology, rules processing, and geoparsing are services widely used in military and intelligence applications.	
	<u>Hardware:</u> <ul style="list-style-type: none"> 3D Graphics accelerator 	<u>Users:</u> <ul style="list-style-type: none"> Multiple Networked
		<u>Availability:</u> <ul style="list-style-type: none"> Commercially Available
Last Modified		
	2006-12-18 19:28:10	

Name	Starlight
URL	http://starlight.pnl.gov/appFile.stm

Description	<p>Brief description: Starlight is a generic information visualization tool, developed by the Pacific Northwest National Laboratory (USA), that is applicable to a wide range of problems.</p> <p>Detailed description: Starlight can be used to analyze computer network data, such as data from Network Intrusion Detection Systems (NIDSs). The data model is flexible in terms of types of information they can associate with nodes (e.g., machine-specific information, such as installed security patches) and edges (e.g., NIDS log data, syslog data). This makes it easier to analyze a wide range of information types that may be available to network administrators. It can also be used for such applications as web mapping (hyperlink structures), national security (multisource intelligence), and hierarchical file systems.</p>	
Context		
<u>Main Functionalities</u>	<ul style="list-style-type: none"> • Automated Layout • Graph Viewing • Network Analysis 	Comments:
<u>Domain</u>	<ul style="list-style-type: none"> • Any 	Comments:
Network Representation		
<u>Dimensionality</u>	<ul style="list-style-type: none"> • 2D • 3D • Geospatial • Temporal 	Comments:
Deployment		
	<u>Type:</u> <ul style="list-style-type: none"> • Standalone Tool 	<u>OS:</u> <ul style="list-style-type: none"> • Windows • Windows 2000 • Windows 2003 • Windows XP
<u>Extensibility</u>		Comments: APIs may be available in version 3.0
<u>Interoperability</u>	XML input/output format. Comes with utilities for converting some other standard formats (e.g., HTML) to XML.	

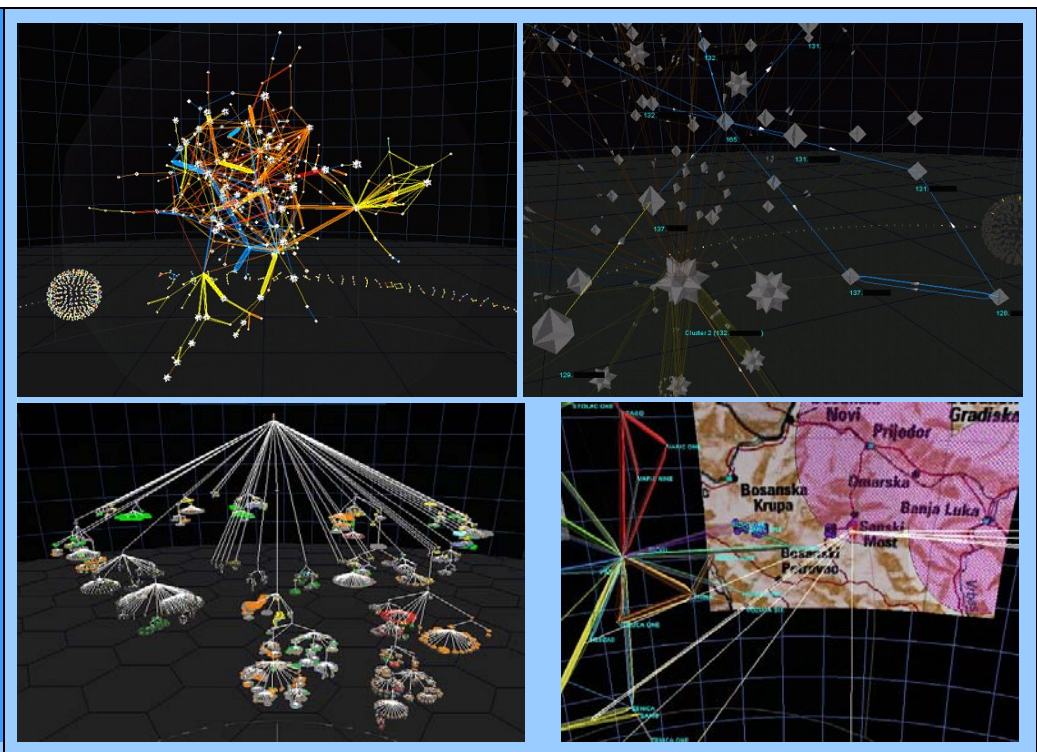
<p>Images</p>	
<p>Last Modified</p>	<p>2006-12-10 16:39:16</p>

<p>Name</p>	<p>Swift3D</p>	
<p>URL</p>	<p>http://www.research.att.com/areas/visualization/projects_software/swift.html</p>	
<p>Description</p>	<p>Brief description: Swift-3D is a system for visually surfing datasets of hundreds of millions of items, with the full data available for answering queries down to individual records.</p> <p>Detailed description:</p>	
<p>Context</p>		
<p><u>Main Functionalities</u></p>	<ul style="list-style-type: none"> • Automated Layout • Graph Manipulation • Graph Viewing 	<p>Comments:</p>
<p><u>Domain</u></p>	<ul style="list-style-type: none"> • Any 	<p>Comments:</p>
<p>Network Representation</p>		
<p><u>Dimensionality</u></p>	<ul style="list-style-type: none"> • 2D • 3D • Geospatial • Temporal 	<p>Comments:</p>
<p>Deployment</p>		

	<u>Type:</u> <ul style="list-style-type: none"> Standalone Tool 	<u>OS:</u>
Last Modified	2006-12-10 16:39:16	

Name	TeCFlow
URL	http://www.ickn.org/JoSS_subm/TeCFlow4JoSS.htm
Description	<p>Brief description: Temporal Communication Flow Visualizer for the temporal analysis of social networks (TeCFlow) addresses three areas of related research: (1) visualization of social networks, (2) temporal analysis of social networks in animated visualizations, and (3) analysis of e-mail networks.</p> <p>Detailed description: TeCFlow automatically generates interactive movies (dynamic views), static graphs (static views), and adjacency matrices (netgraphs) of communication archives.</p>

Context

<u>Main Functionalities</u>	<ul style="list-style-type: none"> Automated Layout Graph Viewing 	Comments:
<u>Domain</u>	<ul style="list-style-type: none"> Computer Networks Social Networks 	Comments:

Network Representation

<u>Links</u>	<ul style="list-style-type: none"> User Defined 	Comments: Any JAVA data type can be used for link/node attributes
<u>Nodes</u>	<ul style="list-style-type: none"> User Defined 	
<u>Layout Algorithms</u>	<ul style="list-style-type: none"> Force-Directed 	Comments: Fruchterman-Reingold algorithm
<u>Dimensionality</u>	<ul style="list-style-type: none"> 2D Temporal 	Comments:

Visual Enhancements

<u>Visual Enhancements</u>	<ul style="list-style-type: none"> Animation/Video 	Comments:
----------------------------	---	------------------

Deployment

	<u>Type:</u> <ul style="list-style-type: none"> Open Source Standalone Tool 	<u>OS:</u> <ul style="list-style-type: none"> Linux Mac OS X Multi-Platform (JAVA) Windows
--	---	--

<u>OS Comments/Dependencies</u>	Requires: MySQL database Java JVM	
<u>Extensibility</u>	<ul style="list-style-type: none"> JAVA 	Comments:
<u>Interoperability</u>	MySQL database.	
	<u>Hardware:</u>	<u>Users:</u> <u>Availability:</u> <ul style="list-style-type: none"> Freeware Research Prototype Shareware
<u>Cost</u>	Free	Comments: Free 'demo' version.
Images		
Last Modified	2006-12-15 20:50:01	

Name	TGRIP: Temporal Graph dRrawing with Intelligent Placement	
URL	http://tgrip.cs.arizona.edu/	
Description	Brief description: TGRIP is an application designed for interactive visualization of large weighted graphs that have a temporal component. Detailed description:	
Context		
<u>Domain</u>	<ul style="list-style-type: none"> Any Social Networks 	Comments:
Network Representation		
<u>Links</u>	<ul style="list-style-type: none"> Weighted 	Comments:

Nodes	<ul style="list-style-type: none"> • Weighted 	
Layout Algorithms	<ul style="list-style-type: none"> • Force-Directed 	Comments:
Dimensionality	<ul style="list-style-type: none"> • 2D • 3D • Temporal 	Comments:
Visual Enhancements		
Visual Enhancements	<ul style="list-style-type: none"> • Animation/Video 	Comments:
Deployment		
	Hardware:	Users:
		Availability: <ul style="list-style-type: none"> • Research Prototype
Images		
Last Modified	2006-12-10 16:39:16	

Name	The Dude
URL	http://www.mikrotik.com/thedude.php
Description	<p>Brief description: The Dude network monitor will automatically scan all devices within specified subnets, draw and layout a map of your networks, monitor services of your devices and alert you in case some service has problems.</p>

	<p>Detailed description: The Dude is a visual and easy to use network monitoring and management system designed to represent network structure in one or more crosslinked graphical diagrams, allowing you to draw (includes automatic network discovery tool) and monitor your network however complicated it might be. The Dude is capable of monitoring particular services run on the network hosts, and alerting you about any changes in their status. It can read statistics from the device monitored and show you graphs of the monitored values, allows you to test and connect to the devices easily, and provides some very basic RouterOS configuration tools.</p>	
<u>Product Version/Status</u>	1.2 2.0b12 (beta)	
Context		
<u>Main Functionalities</u>	<ul style="list-style-type: none"> Automated Layout Graph Manipulation Graph Viewing Network management/discovery 	<p>Comments: Automatic discovery of SNMP-compliant switches and other layer 2 devices.</p>
<u>Domain</u>	<ul style="list-style-type: none"> Computer Networks 	<p>Comments:</p>
	<p><u>User Role:</u></p>	<p><u>Activity:</u></p> <ul style="list-style-type: none"> Monitor Track
Network Representation		
<u>Links</u>		<p>Comments:</p>
<u>Nodes</u>	<ul style="list-style-type: none"> Labelled Symbol 	
<u>Layout Algorithms</u>	<ul style="list-style-type: none"> Tree 	<p>Comments:</p>
<u>Dimensionality</u>	<ul style="list-style-type: none"> 2D 	<p>Comments:</p>
User Interaction		
<u>User Interaction</u>	<ul style="list-style-type: none"> Add/Delete Cut & Paste Drag & Drop Drill down GUI Pan Select Undo/Redo Zoom 	<p>Comments:</p>
Deployment		

	<p>Type:</p> <ul style="list-style-type: none"> Standalone Tool <p>OS:</p> <ul style="list-style-type: none"> Windows Windows 2000 Windows XP
OS Comments/Dependencies	The Dude will run under Linux and MacOS but requires windows emulation (WINE and Darwine respectively)
	<p>Hardware:</p> <p>Users:</p> <ul style="list-style-type: none"> Multiple Networked <p>Availability:</p> <ul style="list-style-type: none"> Freeware
Cost	Free
	Comments:

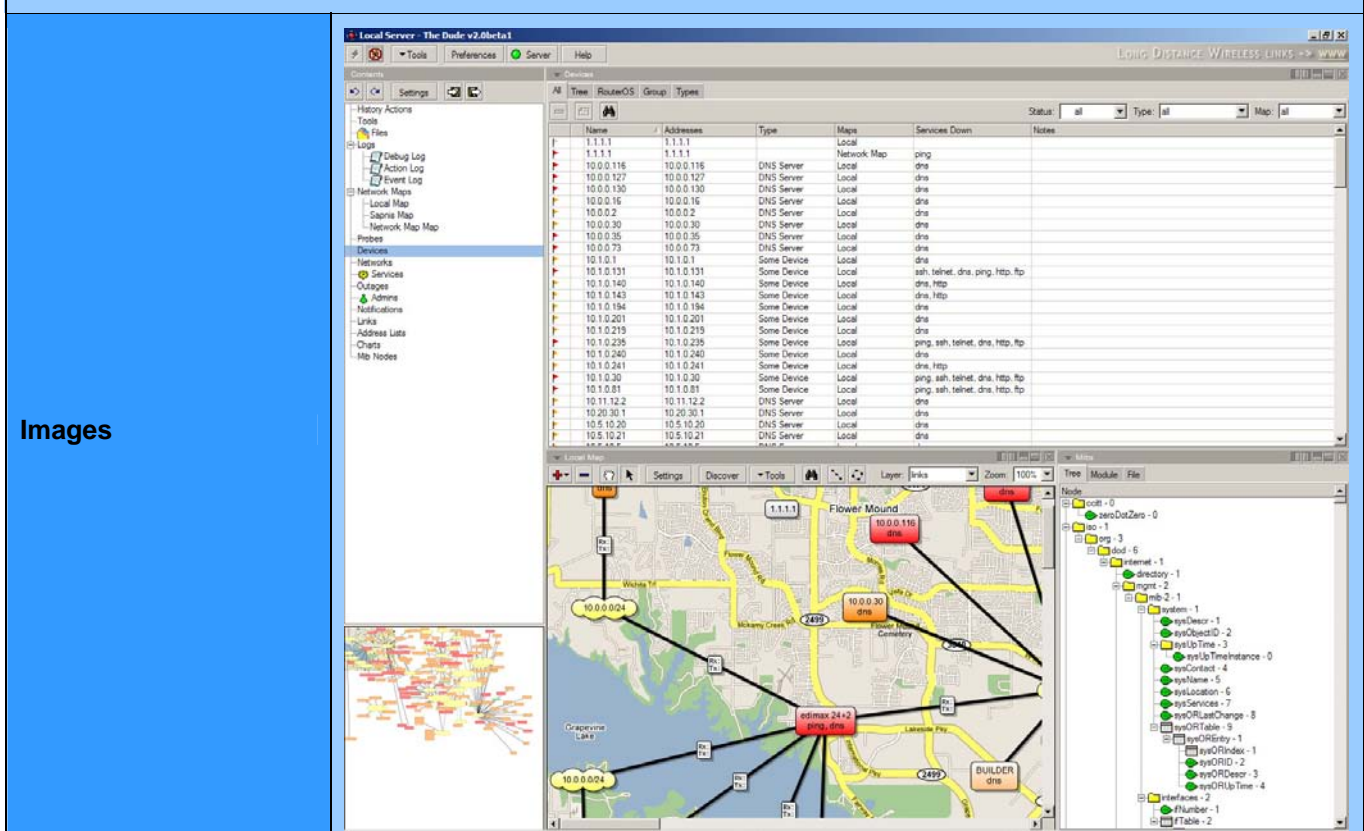

References	Online Manual: http://wiki.mikrotik.com/wiki/Dude_usage_notes
Last Modified	2006-12-16 17:42:06

Name	ThinkMap
URL	http://www.thinkmap.com/

Description	<p>Brief description: Thinkmap is a suite of loosely coupled components to navigate, organize and visualize a large data set.</p> <p>Detailed description: Thinkmap gives users the ability to retrieve a result set from large data sets, and then — through a series of task-specific visualization mechanisms within a graphical user interface — navigate, organize and visualize the result set.</p>	
Product Version/Status	ThinkMap 2.6 Current Support.	
Context		
Main Functionalities	<ul style="list-style-type: none"> Automated Layout Graph Viewing 	<p>Comments: Graphical relationships among data sets.</p>
Domain	<ul style="list-style-type: none"> Any 	<p>Comments:</p>
Network Representation		
Links	<ul style="list-style-type: none"> User Defined 	<p>Comments: Any JAVA data type can be used for link/node attributes</p>
Nodes	<ul style="list-style-type: none"> User Defined 	
Layout Algorithms	<ul style="list-style-type: none"> Clustered Hierarchical Spring Time Line 	<p>Comments:</p>
Dimensionality	<ul style="list-style-type: none"> 2D 3D Temporal 	<p>Comments:</p>
Deployment		
	<p>Type:</p> <ul style="list-style-type: none"> Components for tool building <p>OS:</p> <ul style="list-style-type: none"> Multi-Platform (JAVA) 	
Extensibility	<ul style="list-style-type: none"> JAVA 	<p>Comments: The Core API can be used to create plug-ins to extend the functionality of ThinkMap</p>
Interoperability	<p>ThinkMap can read data from XML and flat files as well as databases.</p> <p>The Datasource API allows the Thinkmap to accept data from virutally any source.</p> <p>The Core API can be used to create application with visualization components.</p>	
Scalability	<p>Max Nodes: 10,001-100,000</p> <p>Max Links: 10,001-100,000</p>	<p>Comments:</p>
Cost	\$5001 - ∞	<p>Comments:</p>

Images

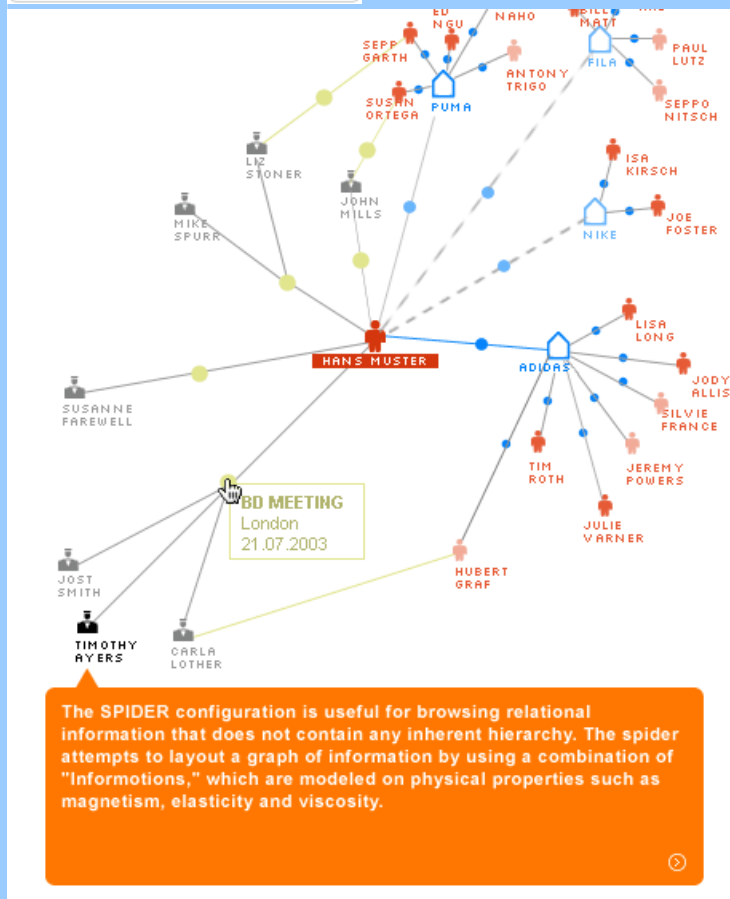

Last Modified

2006-12-10 16:39:16

Name

Tom Sawyer Toolkits

URL

<http://www.tomsawyer.com/home/index.php>

Description

Brief description:

	<p>Customizable graph layout and diagramming toolkits for integration into other applications. A number of graph layout algorithms and graph editing tools are available.</p> <p>Detailed description: Tom Sawyer Software provides a suite of tools and libraries for application developer. These libraries allow application developer to quickly build applications visualization tools that provide robust data management, analysis and rendering.</p> <p>Tom Sawyer provides four products related to graph management and visualization:</p> <ul style="list-style-type: none"> • Tom Sawyer Analysis: Includes libraries for developing graph analysis applications quickly and efficiently. With these products, you can create applications with sophisticated clustering, graph traversal, path analysis, dependency analysis, impact analysis, network analysis and other functions that improve analytic decision making. Available in ActiveX, C++, Java, and .NET editions. • Tom Sawyer Visualization: Enables you to develop graph visualization applications quickly and efficiently. With these products, you can create applications with graph display, viewing and editing technologies presented in an intuitive graphical user interface. Available in ActiveX, JSP, Java, and MFC editions. • Tom Sawyer Layout: Adds scalable graph layout capabilities to your applications. Graph layout technology reveals complex relationships in data by automatically computing diagrams. These diagrams expose the underlying graph structures as well-organized drawings that you can immediately understand. Available in ActiveX, C++, Java, and .NET editions. integrates automatic layout into the Microsoft Visio environment. In seconds, the Tom Sawyer Layout Assistant positions shapes and routes connectors, producing beautiful diagrams within your Visio environment. • Tom Sawyer Layout Assistant: A standalone product that integrates automatic layout into the Microsoft Visio environment. The Tom Sawyer Layout Assistant positions shapes and routes connectors, producing beautiful diagrams within your Visio environment.
--	---

Context		
----------------	--	--

<u>Main Functionalities</u>	<ul style="list-style-type: none"> • Automated Layout • Graph Manipulation • Graph Viewing • Network Analysis 	Comments:
<u>Domain</u>	<ul style="list-style-type: none"> • Any 	Comments:

Network Representation		
-------------------------------	--	--

<u>Layout Algorithms</u>	<ul style="list-style-type: none"> • Circular • Clustered • Hierarchical • Incremental • Orthogonal • Star/Symmetric • Tree 	Comments: All layout style are available to 2nd and 3rd tier products. 1st tier purchasers may select any two layouts
<u>Dimensionality</u>	<ul style="list-style-type: none"> • 2D 	Comments:

Analysis

Network Analysis	<ul style="list-style-type: none"> • Cluster Recognition • Clustering • Connection:Cycle • Connection:Dependency • Connection:Flow • Connection:Path • Impact • Network • Partition 	<p>Comments:</p>
----------------------------------	--	-------------------------

User Interaction

User Interaction	<ul style="list-style-type: none"> • Add/Delete • Clone • Cut & Paste • Drag & Drop • GUI • Reposition • Resize • Select • Zoom 	<p>Comments: Group 1 tools are available to all tiers. Group 2 tools are only available to 2nd and 3rd tier purchasers.</p> <p>Group 1</p> <ul style="list-style-type: none"> • Select • Pan • Marquee zoom • Add tools • Delete Tools • Move • Resize <p>Group 2</p> <ul style="list-style-type: none"> • Interactive zoom • Link navigator • Overview window • Cut • Copy • Paste • Duplicate • Transfer • Reconnect
----------------------------------	--	---

Deployment

Extensibility	<p>Type:</p> <ul style="list-style-type: none"> • Components for tool building 	<p>OS:</p> <ul style="list-style-type: none"> • Linux • Mac OS X • UNIX • Windows
Extensibility	<ul style="list-style-type: none"> • .NET • ActiveX • C++ • JAVA • JSP 	<p>Comments:</p>

Cost	unknown	Comments: Tom Sawyer offer multiple licensing options with multiple product tiers.
Last Modified	2006-12-18 19:29:01	

Name	TopFish	
URL	http://www.research.att.com/areas/visualization/projects_software/topfish.html	
Description	<p>Brief description: TopFish is a viewer for very large and complex graphs. It simplifies the view when nodes are overplotted and hard to distinguish.</p> <p>Detailed description: TopFish allows one to set one or more focus points in the layout. TopFish then shows a very detailed view near a focus, and a simplified, but structurally correct view of the graph further away. The simplified view involves collapsing nodes that are topologically and geometrically close, reducing visual clutter.</p>	

Context

Main Functionalities	<ul style="list-style-type: none"> Automated Layout Graph Viewing 	Comments:
Domain	<ul style="list-style-type: none"> Any 	Comments:

Network Representation

Layout Algorithms	<ul style="list-style-type: none"> Topological Fisheye 	Comments:
Dimensionality	<ul style="list-style-type: none"> 2D 	Comments:

Deployment

	<p>Type:</p> <ul style="list-style-type: none"> Standalone Tool 	OS:
Scalability	<p>Max Nodes: Unlimited</p> <p>Max Links: Unlimited</p>	Comments:

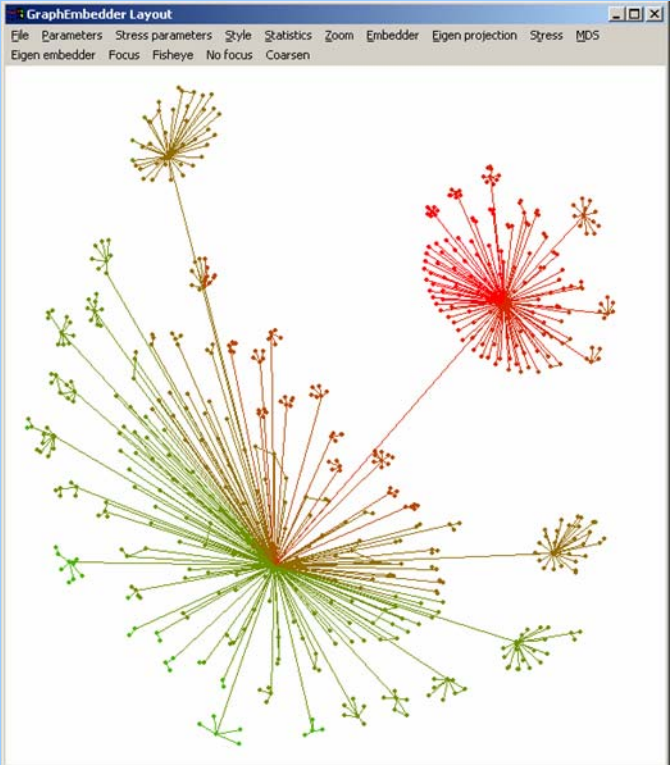
<p>Images</p>	
<p>Last Modified</p>	<p>2006-12-10 16:39:16</p>

<p>Name</p>	<p>TouchGraph</p>
<p>URL</p>	<p>http://touchgraph.sourceforge.net/</p>
<p>Description</p>	<p>Brief description: TouchGraph provides a hands-on way to visualize networks of interrelated information. Networks are rendered as interactive graphs, which lend themselves to a variety of transformations.</p> <p>Detailed description:</p>
<p>Last Modified</p>	<p>2006-12-10 16:39:16</p>

<p>Name</p>	<p>TreePlus</p>
<p>URL</p>	<p>http://www.cs.umd.edu/hcil/treeplus/</p>
<p>Description</p>	<p>Brief description: TreePlus is an interactive graph visualization system based on a tree-style layout</p> <p>Detailed description: Abstract (from "TreePlus: Interactive Exploration of Networks with Enhanced Tree Layouts")</p>

	<p>Despite extensive research, it is still difficult to produce effective interactive layouts for large graphs. Dense layout and occlusion make food webs, ontologies, and social networks difficult to understand and interact with. We propose a new interactive Visual Analytics component called TreePlus that is based on a tree-style layout. TreePlus reveals the missing graph structure with visualization and interaction while maintaining good readability. To support exploration of the local structure of the graph and gathering of information from the extensive reading of labels, we use a guiding metaphor of "Plant a seed and watch it grow." It allows users to start with a node and expand the graph as needed, which complements the classic overview techniques that can be effective at - but often limited to - revealing clusters. We describe our design goals, describe the interface, and report on a controlled user study with 28 participants comparing TreePlus with a traditional graph interface for six tasks. In general, the advantage of TreePlus over the traditional interface increased as the density of the displayed data increased. Participants also reported higher levels of confidence in their answers with TreePlus and most of them preferred TreePlus.</p>
--	---

Context		
---------	--	--

<u>Main Functionalities</u>	<ul style="list-style-type: none"> Automated Layout Graph Manipulation Graph Viewing 	Comments:
-----------------------------	---	-----------

Network Representation		
------------------------	--	--

<u>Links</u>		Comments:
<u>Nodes</u>	<ul style="list-style-type: none"> Labelled 	
<u>Layout Algorithms</u>	<ul style="list-style-type: none"> Tree 	Comments:
<u>Dimensionality</u>	<ul style="list-style-type: none"> 2D 	Comments:

Deployment		
------------	--	--

	<p><u>Hardware:</u></p>	<p><u>Users:</u></p>	<p><u>Availability:</u></p> <ul style="list-style-type: none"> Research Prototype
--	-------------------------	----------------------	--

--	--	--

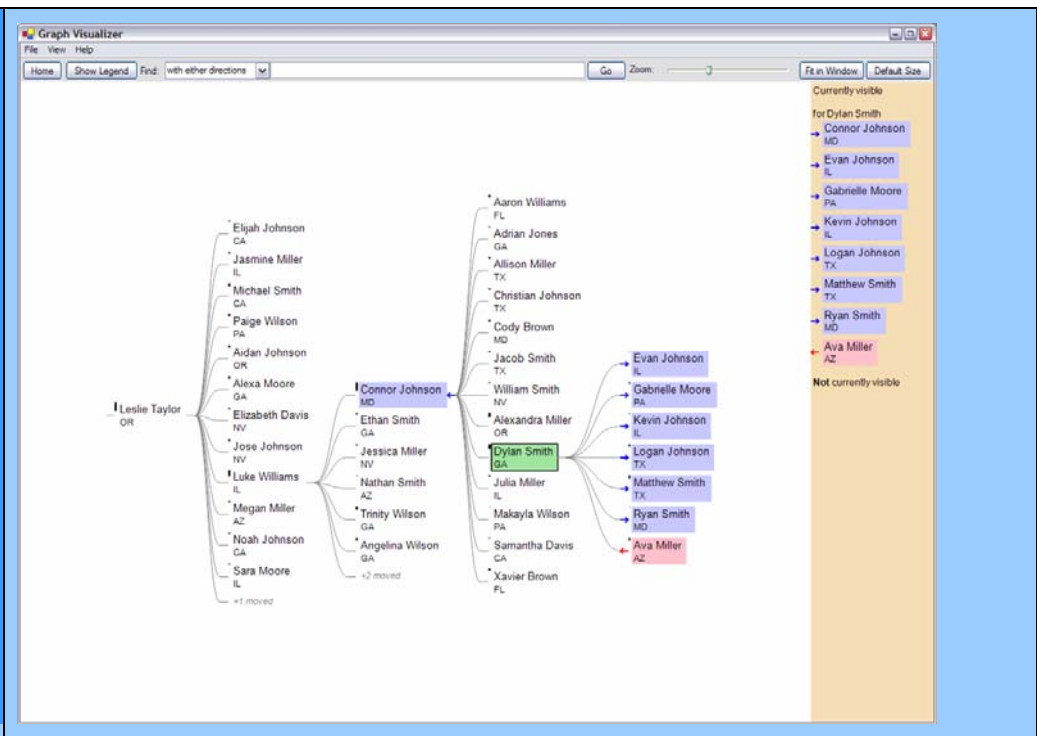
<p>Images</p>	
<p>Last Modified</p>	<p>2006-12-10 16:39:16</p>

<p>Name</p>	<p>Tulip</p>	
<p>URL</p>	<p>http://www.tulip-software.org/</p>	
<p>Description</p>	<p>Brief description: System dedicated to the visualization of huge graphs. It manages graphs with a number of elements (nodes and edges) up to 500,000 on a personal computer</p> <p>Detailed description:</p>	
<p>Product Version/Status</p>	<p>2.0.6 (25-Sep-2006) 3.0.0 Beta1 (27-Oct-2006)</p>	
<p>Context</p>		
<p>Main Functionalities</p>	<ul style="list-style-type: none"> Automated Layout Graph Manipulation Graph Viewing 	<p>Comments:</p>
<p>Domain</p>	<ul style="list-style-type: none"> Any 	<p>Comments:</p>
<p>Network Representation</p>		
<p>Layout Algorithms</p>	<ul style="list-style-type: none"> ACE Circular Clustered GEM Hierarchical 	<p>Comments:</p>

	<ul style="list-style-type: none"> • Radial Tree • Random • Spring • Spring (Tutte) • Tree • Tree:Walker 	
<u>Dimensionality</u>	<ul style="list-style-type: none"> • 2D • 3D 	Comments:
Analysis		
<u>Network Analysis</u>	<ul style="list-style-type: none"> • Cohesion:Bi-Component 	Comments:
User Interaction		
<u>User Interaction</u>	<ul style="list-style-type: none"> • GUI • Pan • Rotate • Select • Zoom 	Comments: Provides edit functions such as: deselect all, reverse selection , build a new view, reverse selected edges direction and delete selection.
Deployment		
	<u>Type:</u> <ul style="list-style-type: none"> • Components for tool building • Open Source - GPL • Standalone Tool 	<u>OS:</u> <ul style="list-style-type: none"> • Linux • Windows
<u>Extensibility</u>	<ul style="list-style-type: none"> • C++ 	Comments: Provides a plug-in frameworks so that new functions can be easily added.
<u>Interoperability</u>	File Formats: GML import TLP import (Tulip native format) The Tulip class library can be incorporated into other application.	
<u>Scalability</u>	Max Nodes: Unlimited Max Links: Unlimited	Comments:
	<u>Hardware:</u>	<u>Users:</u>
		<u>Availability:</u> <ul style="list-style-type: none"> • Freeware • In Development • In Use
<u>Cost</u>	Free	Comments:
		

Images

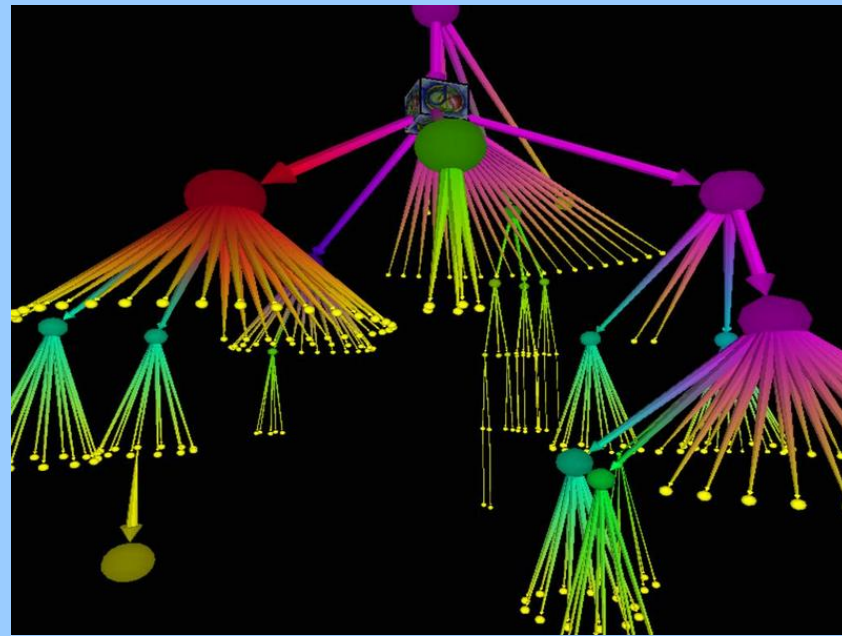

Yulip

File Edit Property Clustering View Windows Options Help

Labels
 Arrows
 Interpolation
 Edges
more ...

3D Strahler
Backgrounds Film
 3D Edges Orthogonal
Label density

Property Element Hierarchy

Column 1

- import
- Bubble tree
- Cone Tree
- Hierarchical Ortho
- Hierarchical
- Radial Tree
- TreeMap

Ready, Nodes:317, Edges:316

A software interface showing six different visualization views of the hierarchical tree data. The views are arranged in a 2x3 grid. The top-left view is a 3D perspective view of the tree. The top-middle view is a 2D view of the tree with a color gradient. The top-right view is a heatmap representation of the tree. The bottom-left view is a 2D view of the tree with a color gradient. The bottom-middle view is a 2D view of the tree with a color gradient. The bottom-right view is a 2D view of the tree with a color gradient. The interface includes a menu bar (File, Edit, Property, Clustering, View, Windows, Options, Help) and a toolbar with various icons. A status bar at the bottom indicates 'Ready, Nodes:317, Edges:316'.

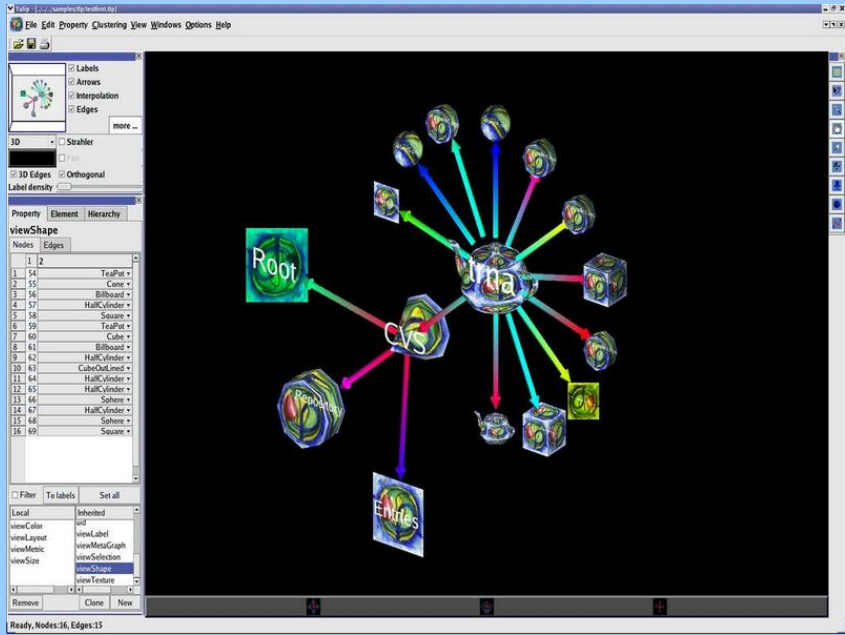
	
Last Modified	2006-12-18 19:30:02

Name	UCINET 6 / NetDraw	
URL	http://www.analytictech.com/ucinet.htm	
Description	<p>Brief description: Software packages for the analysis (UCINET) and visualization (NetDraw) of social network data.</p> <p>Detailed description:</p>	
<u>Product Version/Status</u>	<p>UCINET 6.114 (23 March 06)</p> <p>NetDraw 2.31 (19 Mar 06)</p> <p>Both products seem to be updated regularly</p>	
Context		
<u>Main Functionalities</u>	<ul style="list-style-type: none"> Automated Layout Graph Viewing Network Analysis 	Comments:
<u>Domain</u>	<ul style="list-style-type: none"> Social Networks 	Comments:
Network Representation		
<u>Layout Algorithms</u>	<ul style="list-style-type: none"> Circular MDS 	Comments:

	<ul style="list-style-type: none"> • Spring 	
<u>Dimensionality</u>	<ul style="list-style-type: none"> • 2D 	Comments:
Analysis		
<u>General Analysis</u>	<ul style="list-style-type: none"> • Statistics:ANOVA • Statistics:Autocorrelation • Statistics:Correspondence • Statistics:Factor Analysis • Statistics:Matrix QAP • Statistics:MDS • Statistics:Regression • Statistics:T-Test 	Comments:
<u>Network Analysis</u>	<ul style="list-style-type: none"> • Centrality:Betweenness • Centrality:Closeness • Centrality:Degree • Centrality:Eigenvector • Centrality:Flow Betweenness • Centrality:Information • Cluster Recognition • Cohesion:Bi-Component • Cohesion:k-Core • Cohesion:k-Plex • Cohesion:Lambda Set • Cohesion:n-Clan • Cohesion:n-Clique • Connection:Accessibility • Connection:Flow • Connection:Max. Flow • Connection:Path • Equivalence:Regular • Equivalence:Structural • Equivalence:Automorphic 	Comments:
Deployment		
	<u>Type:</u> <ul style="list-style-type: none"> • Standalone Tool 	<u>OS:</u> <ul style="list-style-type: none"> • Windows
<u>Interoperability</u>	<p>NetDraw reads Ucinet datasets (the ##h and ##d files), Ucinet DL text files, Pajek files (net, clu and vec), and the program's own VNA text file format, which allows the user to combine node attributes with tie information. It can save data to Pajek and to Mage. It can save diagrams as EMF, WMF, BMP and JPG files.</p> <p>UCINET can read RAW, excel, and DL files.</p>	
<u>Scalability</u>	<p>Max Nodes: 1001-10,000</p> <p>Max Links:</p>	Comments: Can handle a maximum of 32,767 nodes (with some exceptions) although practically speaking many procedures get too slow around 5,000 -

	Unknown	10,000 nodes.																
Cost	\$101 - \$1000	Comments:																
		<table border="1"> <thead> <tr> <th></th> <th colspan="3">Type of Customer</th> </tr> <tr> <th></th> <th>Full-time Student</th> <th>Faculty</th> <th>Non-Academic</th> </tr> </thead> <tbody> <tr> <td>UCINET 6 for Windows</td> <td>\$40</td> <td>\$150</td> <td>\$250</td> </tr> <tr> <td>Anthropac (for DOS)</td> <td>\$30</td> <td>\$75</td> <td>\$75</td> </tr> </tbody> </table>		Type of Customer				Full-time Student	Faculty	Non-Academic	UCINET 6 for Windows	\$40	\$150	\$250	Anthropac (for DOS)	\$30	\$75	\$75
			Type of Customer															
			Full-time Student	Faculty	Non-Academic													
UCINET 6 for Windows	\$40	\$150	\$250															
Anthropac (for DOS)	\$30	\$75	\$75															
NetDraw is freely available.																		

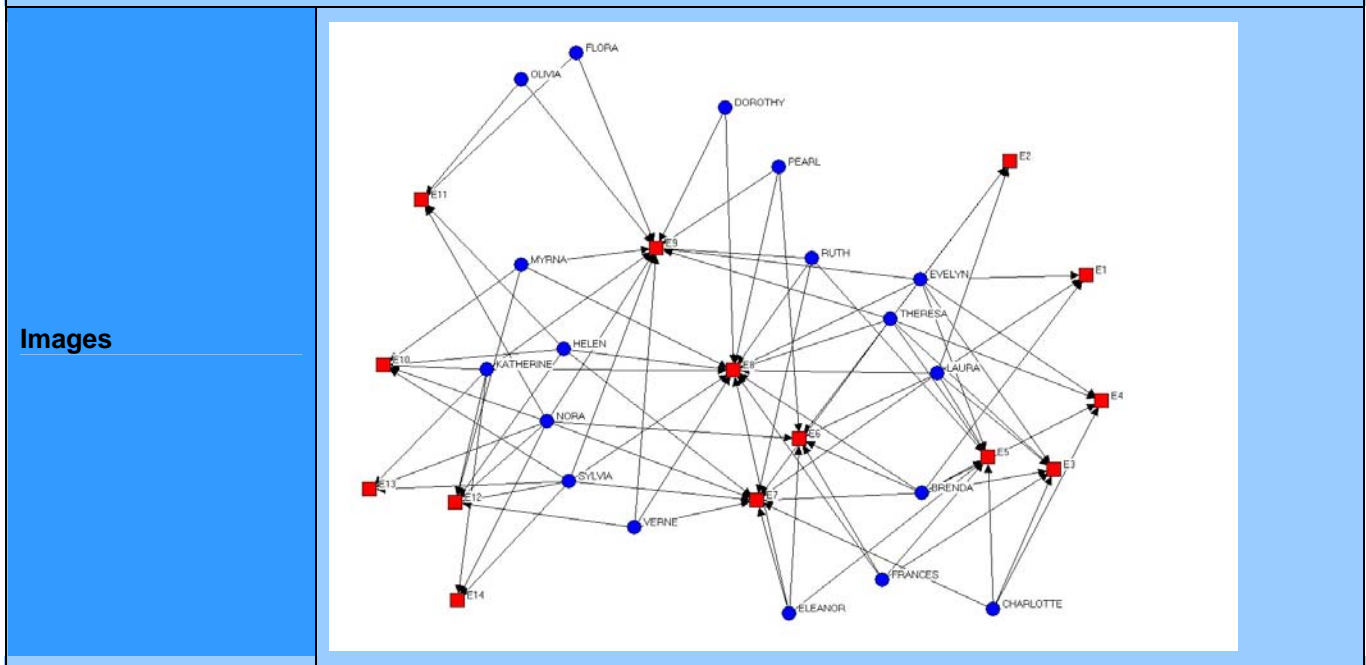

Last Modified 2006-12-10 16:39:16

Name	uDraw
URL	http://www.informatik.uni-bremen.de/uDrawGraph/en/index.html
Description	Brief description: A multi-platform visualization tool for drawing directed graphs

	Detailed description:	
<u>Product Version/Status</u>	3.1.1 Seems to still be maintained	
Context		
<u>Main Functionalities</u>	<ul style="list-style-type: none"> Automated Layout Graph Viewing 	Comments:
Network Representation		
<u>Layout Algorithms</u>	<ul style="list-style-type: none"> Incremental 	Comments:
<u>Dimensionality</u>	<ul style="list-style-type: none"> 2D 	Comments:
Deployment		
	<p><u>Type:</u></p> <ul style="list-style-type: none"> Components for tool building Standalone Tool 	<p><u>OS:</u></p> <ul style="list-style-type: none"> Linux Mac OS X UNIX Windows
<u>Interoperability</u>	<p>Provides an API so that uDraw functions may be access from other applications.</p> <p>uDraw(Graph) can export graph visualizations to Postscript, GIF, TIFF, and PNG formats</p>	
Last Modified		
	2006-12-10 16:39:16	

Name	VANTED	
URL	http://vanted.ipk-gatersleben.de/index.php?file=doc0.html	
Description	<p>Brief description: Visualization and Analysis of Networks containing Experimental Data</p> <p>Detailed description: This system makes it possible to load and edit graphs, which may represent biological pathways or functional hierarchies. It is possible to map experimental datasets onto the graph elements and visualize time series data or data of different genotypes or environmental conditions in the context of a the underlying biological processes. Built-in statistic functions allow a fast evaluation of the data (e.g. t-Test or correlation analysis).</p>	
<u>Product Version/Status</u>	1.0	
Context		
<u>Main Functionalities</u>	<ul style="list-style-type: none"> Automated Layout 	Comments:

	<ul style="list-style-type: none"> Graph Manipulation Graph Viewing Network Analysis 	
<u>Domain</u>	<ul style="list-style-type: none"> Any Biology 	Comments:
Network Representation		
<u>Type</u>	<ul style="list-style-type: none"> Directed 	
<u>Links</u>	<ul style="list-style-type: none"> Coloured 	Comments:
<u>Nodes</u>	<ul style="list-style-type: none"> Coloured Labelled Symbol 	
<u>Layout Algorithms</u>	<ul style="list-style-type: none"> Circular Clustered Force-Directed Grid Radial Tree Spring Tree 	Comments:
<u>Dimensionality</u>	<ul style="list-style-type: none"> 2D 	Comments:
Analysis		
<u>General Analysis</u>	<ul style="list-style-type: none"> Statistics:Correlation Statistics:T-Test 	Comments:
<u>Visual Abstraction</u>	<ul style="list-style-type: none"> Chart:Line Chart:Scatter 	Comments:
Deployment		
	<u>Type:</u> <ul style="list-style-type: none"> Standalone Tool 	<u>OS:</u> <ul style="list-style-type: none"> Multi-Platform (JAVA)
<u>OS Comments/Dependencies</u>	requires JRE 5.0	
<u>Extensibility</u>	<ul style="list-style-type: none"> BeanShell JAVA JRuby 	Comments: It is possible to write BeanShell or JRuby scripts in order to perform data processing. This application is based on Gravisto, an editor for graphs and a toolkit for implementing graph visualization algorithms. This system is customizable to many needs as it uses an extensive plugin system for all main structures.

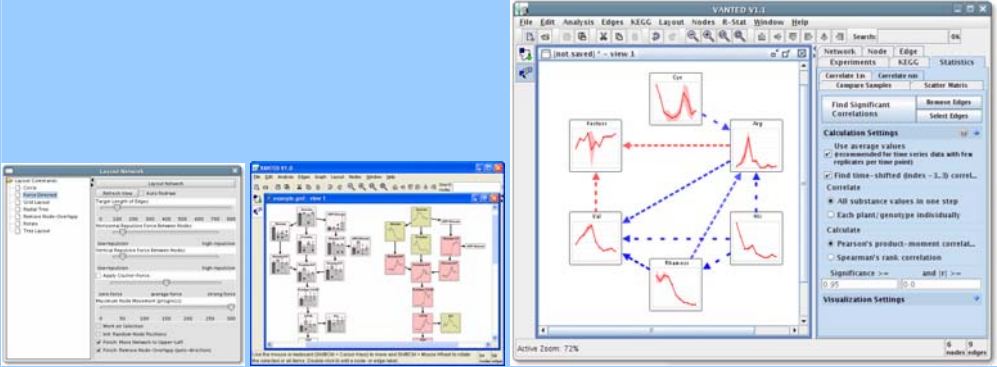
<p><u>Interoperability</u></p>	<p>Can interface with R statistics software to perform further analysis.</p> <p>Save/Load GML files.</p>
<p>Images</p>	
<p>Last Modified</p>	<p>2006-12-10 16:39:16</p>

<p>Name</p>	<p>ViAGraph</p>	
<p>URL</p>	<p>http://eprints.rclis.org/archive/00006083/</p>	
<p>Description</p>	<p>Brief description: A research paper discussing graph visualization and analysis techniques used in a tool called ViAGraph.</p> <p>Detailed description: Abstract</p> <p>Graphs are common representations that can capture the structure and then can model a wide range of data and knowledge. In this paper, we present and discuss the functionalities of ViAGraph a tool for graph visualization and analysis. ViAGraph is meant to assist the user in exploring raw information in order to unveil interesting and useful information thru both query/answer and interactively guided data examination interactions. The paper presents a bunch of ideas and techniques related to graph visualization and exploration. Our main contributions are: 1. We propose a new approach of node placement based on 'geographic' constraints. 2. We discuss a novel analysis method based on graph comparison. Strengths and weaknesses of the proposed methods are discussed.</p>	
<p>Context</p>		
<p><u>Main Functionalities</u></p>	<ul style="list-style-type: none"> • Automated Layout • Graph Viewing • Network Analysis 	<p>Comments:</p>
<p><u>Domain</u></p>	<ul style="list-style-type: none"> • Any • Social Networks 	<p>Comments:</p>
<p>Network Representation</p>		
<p><u>Links</u></p>	<ul style="list-style-type: none"> • Weighted 	<p>Comments:</p>

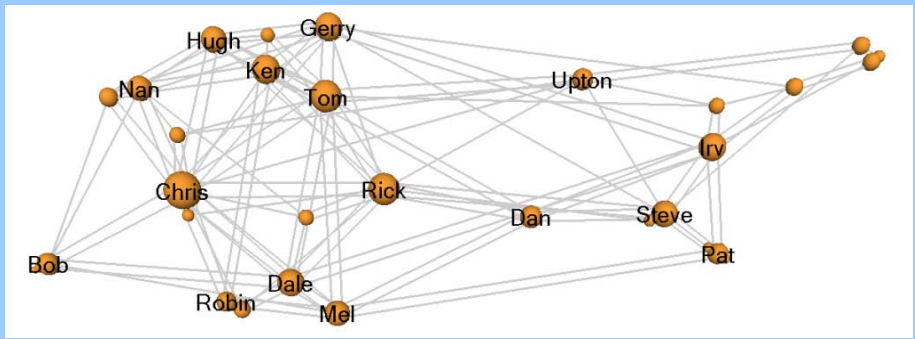
Nodes	<ul style="list-style-type: none"> • Labelled 	
Layout Algorithms	<ul style="list-style-type: none"> • Clustered • Force-Directed • Spring • Spring Ed • Spring KK 	Comments:
Analysis		
Network Analysis	<ul style="list-style-type: none"> • Centrality:Betweenness • Centrality:Closeness • Centrality:Degree • Centrality:Eigenvector • Equivalence:Structural 	Comments:
Deployment		
	Type: <ul style="list-style-type: none"> • Standalone Tool 	OS:
	Hardware:	Users: Availability: <ul style="list-style-type: none"> • Research Prototype
Images		
		
References	see ViAGraphFinalVersion.pdf	
Last Modified	2006-12-10 16:39:16	

Name	Visone
URL	http://visone.info/download/
Description	<p>Brief description: Visone is a long-term research project, in which models and algorithms to integrate and advance the analysis and visualization of social networks are being developed.</p> <p>Detailed description:</p>

Product Version/Status	2.2.5 (2006-11-27)	
Context		
Main Functionalities	<ul style="list-style-type: none"> Automated Layout Graph Manipulation Graph Viewing Network Analysis 	Comments:
Domain	<ul style="list-style-type: none"> Social Networks 	Comments:
Network Representation		
Layout Algorithms	<ul style="list-style-type: none"> Hierarchical (Sugiyama) Radial Spectral 	Comments:
Analysis		
Network Analysis	<ul style="list-style-type: none"> Centrality:Betweenness Centrality:Closeness Centrality:Graph Centrality:PageRank Centrality:Stress 	Comments:
Deployment		
	Type: <ul style="list-style-type: none"> Standalone Tool 	OS: <ul style="list-style-type: none"> Multi-Platform (JAVA)
OS Comments/Dependencies	Requires: Sun Java Runtime Environment (JRE) 5.0	
Interoperability	Support import/export of GraphML files. Visualizations can be exported to SVG and PS files.	
	Hardware:	Users: <ul style="list-style-type: none"> Freeware In Development Research Prototype
Cost	Free - For academic use	Comments:

Images

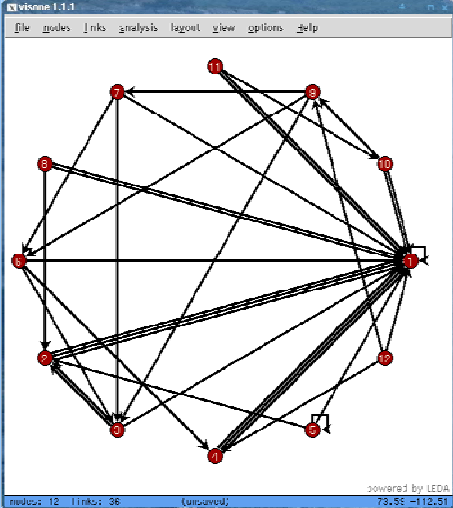
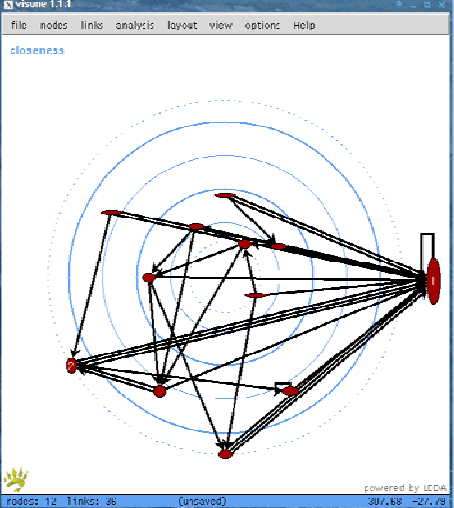
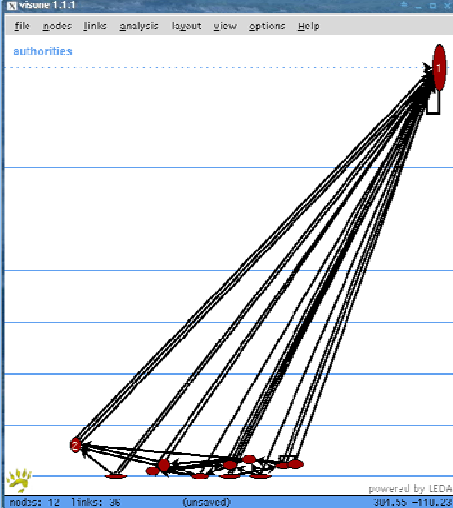
network node setup

nodes: 1 7 3 6 8 4 9 11 5 12 10 2

position

x:

y:

appearance

shape: circle oval square rectangle diamond

color:

width:

height:

label

color:

position:

name:

value:

display:

current score is undefined

Last Modified

2006-12-18 23:09:02

Name	VisuaLinks	
URL	http://www.visualanalytics.com/Products/VisuaLinks.cfm	
Description	<p>Brief description: VisuaLinks is a platform-independent, graphical analysis tool used to discover patterns, trends, associations and hidden networks in any number and type of data sources.</p> <p>Detailed description:</p>	
Context		
Main Functionalities	<ul style="list-style-type: none"> Automated Layout Graph Manipulation 	<p>Comments: VisuaLinks has been used with many types of</p>

	<ul style="list-style-type: none"> • Graph Viewing • Network Analysis 	domains of data, such as network traffic, medical patterns, pharmaceutical research, insurance fraud, bank transactions, drug trafficking, criminal investigations, and terrorism.
Domain	<ul style="list-style-type: none"> • Any 	Comments:
Network Representation		
Layout Algorithms	<ul style="list-style-type: none"> • Centrality Placement • Group By • Level Span • Parallel Coordinates • Starburst • Temporal Grid • Time Line • Weighted Layout 	Comments:
Dimensionality	<ul style="list-style-type: none"> • 2D • 3D • Geospatial • Temporal 	Comments: The VisuaLinks Mapping feature incorporates a geographical information sub-system. This capability lets users plot data with geographical references on a variety of graphical maps included with VisuaLinks.
Analysis		
General Analysis	<ul style="list-style-type: none"> • Data Transformation:Link Set • Data Transformation:Node Set • Statistics:Cluster • Statistics:Correlation 	Comments:
Network Analysis	<ul style="list-style-type: none"> • Centrality:Closeness • Centrality:Graph • Cluster Recognition • Clustering • Connection:Distance • Graph Structure 	Comments:
User Interaction		
User Interaction	<ul style="list-style-type: none"> • Cut & Paste • Drag & Drop • GUI • Layers • Pan • Reposition • Rotate • Scroll • Select • Undo/Redo 	Comments:

	<ul style="list-style-type: none"> • Web/CGI • Zoom 		
Deployment			
	<p>Type:</p> <ul style="list-style-type: none"> • Standalone Tool 	<p>OS:</p> <ul style="list-style-type: none"> • AIX • HP-UX • Linux • Multi-Platform (JAVA) • Solaris • UNIX • Windows • Windows 2000 • Windows NT • Windows XP 	
<p><u>OS Comments/ Dependencies</u></p>	<p>When running the VisuaLinks Client as an installed application:</p> <p>Server: -Java Runtime Environment (JRE) 1.5 -Database drivers (ODBC, JDBC, or native Java drivers)</p> <p>Client: -Java Runtime Environment (JRE) 1.5 -.NET Framework 2.0 (on any machine that will use the i2-to-VisuaLinks Conversion tools)</p> <p>When running the VisuaLinks Client as an applet:</p> <p>Server: -Java Runtime Environment (JRE) 1.5 -Windows 2000 Server/Advanced Server with Internet Information Services (IIS) 5.0 or Tomcat (included with the VisuaLinks software) -Database drivers (ODBC, JDBC, or native Java drivers)</p> <p>Client: -Java Runtime Environment (JRE) 1.5 -.NET Framework 2.0 (on any machine that will use the i2/VisuaLinks Conversion tools) -Netscape 4.71 (or higher) or Internet Explorer 5.5 (or higher)</p>		
<p><u>Extensibility</u></p>	<ul style="list-style-type: none"> • JAVA 	<p>Comments: An open API is being developed for version 4.0</p>	
<p><u>Interoperability</u></p>	<p>VisuaLinks can save data in a variety of formats including database, HTML, XML, image and text files</p>		
	<p>Hardware:</p>	<p>Users:</p> <ul style="list-style-type: none"> • Multiple • Networked 	<p>Availability:</p> <ul style="list-style-type: none"> • Commercially Available

Images

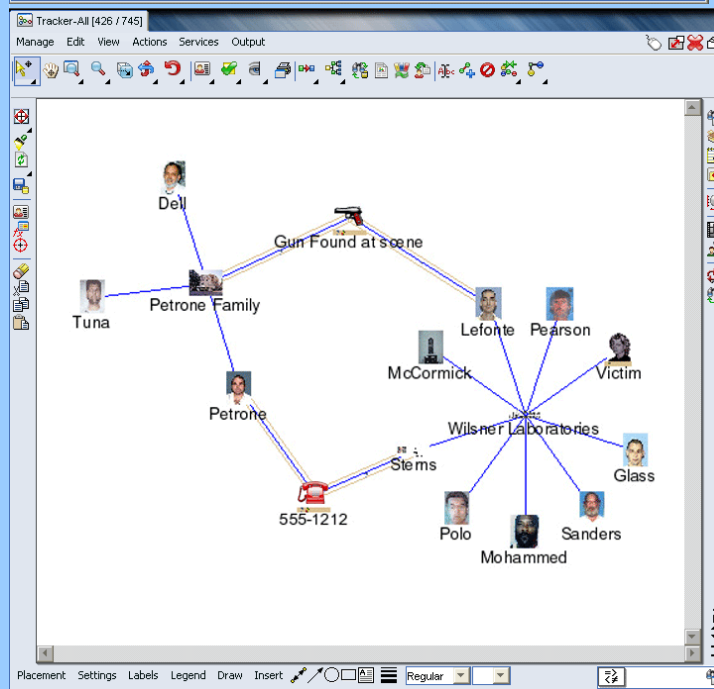
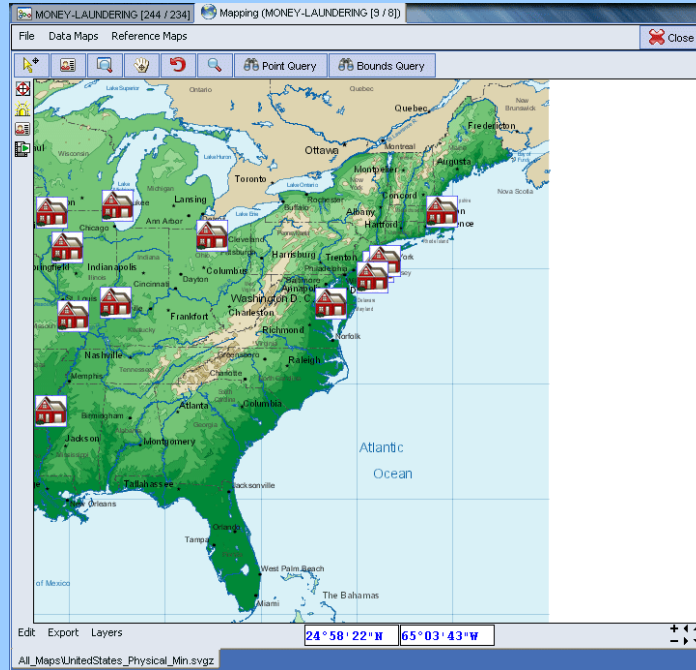

Last Modified

2006-12-18 20:09:10

Name

Visualyzer

URL

<http://www.mdlogix.com/visualyzer.htm>

Description

Brief description:

Visualyzer is an interactive tool for entering, visualizing and analyzing network data.

	Detailed description:	
Context		
<u>Main Functionalities</u>	<ul style="list-style-type: none"> Automated Layout Graph Manipulation Graph Viewing Network Analysis 	Comments:
<u>Domain</u>	<ul style="list-style-type: none"> Social Networks 	Comments:
Deployment		
	<u>Type:</u> <ul style="list-style-type: none"> Standalone Tool 	<u>OS:</u> <ul style="list-style-type: none"> Windows Windows 2000 Windows XP
	<u>Hardware:</u>	<u>Users:</u> <ul style="list-style-type: none"> Single
		<u>Availability:</u> <ul style="list-style-type: none"> Commercially Available
<u>Cost</u>	\$101 - \$1000	Comments: VisuaLyzer (Student): \$64 VisuaLyzer (Faculty): \$256
Last Modified		
	2006-12-18 23:03:15	

Name	VRMLGraph	
URL	http://vrmgraph.i-scream.org.uk/	
Description	Brief description: An open-source JAVA application for creating 3D representations of graphs. Detailed description:	
<u>Product Version/Status</u>	1.0 (April 5, 2001) No longer seems supported.	
Context		
<u>Main Functionalities</u>	<ul style="list-style-type: none"> Automated Layout 	Comments: VRMLGraph Just produces VRML files. It has no viewing capability. In order to view the resulting 3D graph, a VRML file viewer is required.
Network Representation		
<u>Layout Algorithms</u>	<ul style="list-style-type: none"> Spring 	Comments:

<u>Dimensionality</u>	<ul style="list-style-type: none"> • 3D 	Comments:
Deployment		
	<u>Type:</u> <ul style="list-style-type: none"> • Open Source - GPL • Standalone Tool 	<u>OS:</u>
<u>Extensibility</u>	<ul style="list-style-type: none"> • JAVA 	Comments:
<u>Interoperability</u>	Output the current visualization to a VRML file.	
	<u>Hardware:</u>	<u>Users:</u> <ul style="list-style-type: none"> • Freeware • Unsupported
<u>Cost</u>	Free	Comments:
Last Modified		
2006-12-15 20:55:15		

Name	Walrus
URL	http://www.caida.org/tools/visualization/walrus/
Description	<p>Brief description: Walrus is a tool for interactively visualizing large directed graphs in three-dimensional space.</p> <p>Detailed description: Walrus is a tool for interactively visualizing large directed graphs in three-dimensional space. It is technically possible to display graphs containing a million nodes or more, but visual clutter, occlusion, and other factors can diminish the effectiveness of Walrus as the number of nodes, or the degree of their connectivity, increases. Thus, in practice, Walrus is best suited to visualizing moderately sized graphs that are nearly trees. A graph with a few hundred thousand nodes and only a slightly greater number of links is likely to be comfortable to work with.</p> <p>Walrus computes its layout based on a user-supplied spanning tree. Because the specifics of the supplied spanning tree greatly affect the resulting display, it is crucial that the user supply a spanning tree that is both meaningful for the underlying data and appropriate for the desired insight. The prominence and orderliness that Walrus gives to the links in the spanning tree, in contrast to all other links, means that an arbitrarily chosen spanning tree may create a misleading or ineffective visualization. Ideally, the input graphs should be inherently hierarchical.</p> <p>Walrus uses 3D hyperbolic geometry to display graphs under a fisheye-like distortion. At any moment, the amount of magnification, and thus the level of visible detail, varies across the display. This allows the user to examine the fine details of a small area while always having a view of the whole graph available as a frame of reference. Graphs are rendered inside a sphere that contains the Euclidean</p>

	<p>projection of 3D hyperbolic space. Points within the sphere are magnified according to their radial distance from the center. Objects near the center are magnified, while those near the boundary are shrunk. The amount of magnification decreases continuously and at an accelerated rate from the center to the boundary, until objects are reduced to zero size at the latter, which represents infinity. By bringing different parts of a graph to the magnified central region, the user can examine every part of the graph in detail.</p>	
Product Version/Status	<p>0.6.3 (Mar 30, 2005) There may still be active development; however, there can be a couple years between updates.</p>	
Context		
Main Functionalities	<ul style="list-style-type: none"> Automated Layout Graph Viewing 	Comments:
Domain	<ul style="list-style-type: none"> Any 	Comments:
Network Representation		
Type	<ul style="list-style-type: none"> Directed 	
Links	<ul style="list-style-type: none"> Pre-Defined Attributes (see comments) 	Comments: Attributes: Colours
Nodes	<ul style="list-style-type: none"> Labelled Pre-Defined Attributes (see comments) 	
Layout Algorithms	<ul style="list-style-type: none"> Hyperbolic H3 	Comments: Walrus uses a modified version of the H3 algorithm developed by Munzner.
Dimensionality	<ul style="list-style-type: none"> 3D 	Comments:
User Interaction		
User Interaction	<ul style="list-style-type: none"> Zoom 	Comments:
Deployment		
	<p>Type:</p> <ul style="list-style-type: none"> Open Source - GPL Standalone Tool 	<p>OS:</p> <ul style="list-style-type: none"> Multi-Platform (JAVA)
Extensibility	<ul style="list-style-type: none"> JAVA 	Comments:
Interoperability	Only LibSea graph files (a documented CAIDA-developed input format) are supported	
Scalability	Max Nodes: Unlimited	Comments:

	Max Links: Unlimited	
	<u>Hardware:</u>	<u>Users:</u>
		<u>Availability:</u> <ul style="list-style-type: none"> • Freeware • Unsupported
<u>Cost</u>	Free	<u>Comments:</u>

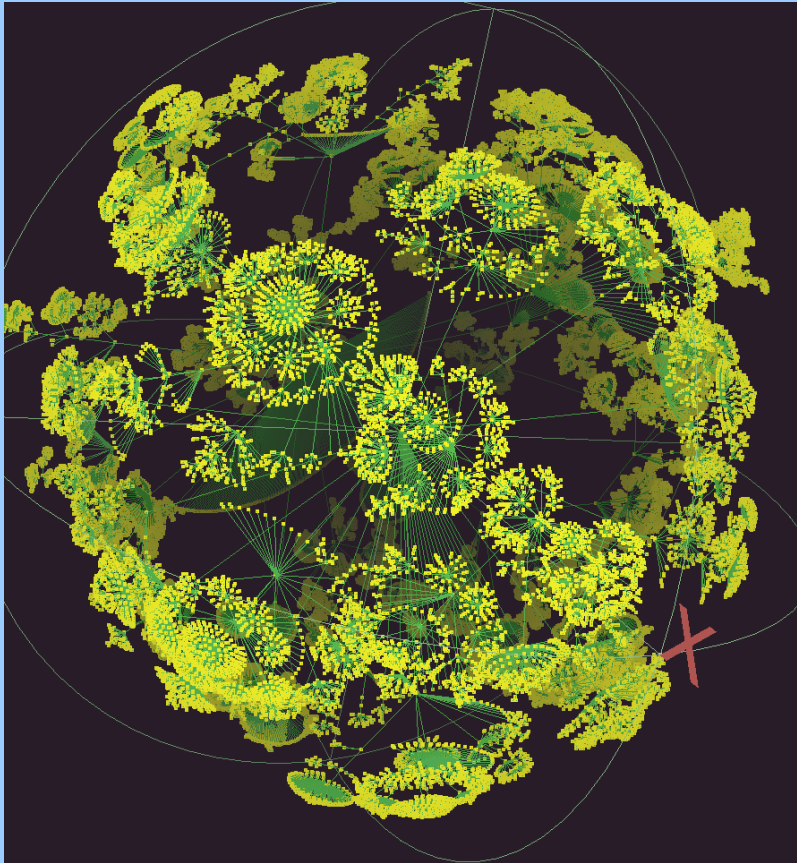

Images	<div data-bbox="467 552 1263 1409" data-label="Figure"> </div>
---------------	--

	
Last Modified	2006-12-15 20:54:35

Name	Web NMS
URL	http://www.adventnet.com/products/webnms/index.html
Description	<p>Brief description: AdventNet Web NMS is network management framework for building custom element and network management systems.</p> <p>Detailed description: AdventNet Web NMS Features</p> <ul style="list-style-type: none"> * Event Collection: Simultaneous receipt of events from any intelligent device, resource, or software entity. Supports the reporting of alarm conditions in a near real-time or scheduled manner. * Alarm Correlation and Filtering: Efficiently handles lengthy alarm lists with robust capability to correlate and filter alarms. * Resource Status Displays: A single window provides an efficient, graphical overview of the status of all managed resources. * Active Alarms Display: A consolidated list of active or "open" alarms compiled across all managed resources provides an overview of fault localization and correction tasks that are currently in progress. * Automatic Discovery: Uses industry standard protocols (e.g., SNMP, TL1) or

	<p>customer-specific messaging adapters, managed resources are automatically discovered and polled for updates to their configuration attributes.</p> <ul style="list-style-type: none"> * Managed Resource Domains: Administrator can conveniently group the discovered managed resources into a set of managed resource domains using a point-and-click interface. * Containment Tree View: Rapid browsing through the entire inventory is supported through the containment hierarchy display. * Graphical Topology View: This powerful consolidated view displays the configuration and status of the entire managed resource inventory. * Resource Provisioning: Through a convenient, single-click operation, managed resources can be placed in one of several service states such as “working”, “unavailable”, or “standby”. This high impact operation confirms that the requestor has appropriate permissions before fulfilling the request. * Remote Management : Enables management of remote locations deploying Distributed Mediation Servers locally. The servers can correlate network data, forwarding relevant information to the central site. These servers support buffering to prevent network data loss and can even work on dial-ups. * Software Image Downloads: Provides a powerful facility to orchestrate the organized download of software images. * Data Collection: Scalable application architecture powers the simultaneous collection of measurements from multiple managed resources across the network. * Resource Configuration: Managed resources typically support a number of settable attributes including alarm thresholds, logical addresses, and device specific parameters like data rates. The user can set such attributes for a single managed resource or a group of managed resources. * Performance Computation: Collected data is analyzed, filtered, and aggregated to produce performance metrics that are relevant to the operations staff such as user-oriented transaction response time or service availability. * Real-time Graphical Displays: Intuitive line charts and bar charts provide operations staff with quick snapshots of the performance metrics over time. * Security Domains: Fine-grained control of access to critical managed resources is accomplished through carefully defined security domains. * Audit Log: A detailed log of all access permission requests and responses supports the analysis of resource usage patterns as well as attempts to breach access control.
--	---

Context

<u>Main Functionalities</u>	<ul style="list-style-type: none"> • Automated Layout • Graph Manipulation • Graph Viewing • Network management/discovery 	Comments:
<u>Domain</u>	<ul style="list-style-type: none"> • Computer Networks 	Comments:
	<p><u>User Role:</u></p>	<p><u>Activity:</u></p> <ul style="list-style-type: none"> • Monitor • Track

Network Representation

<u>Links</u>	<ul style="list-style-type: none"> • Labelled 	Comments:
<u>Nodes</u>	<ul style="list-style-type: none"> • Labelled • Symbol 	

Layout Algorithms	<ul style="list-style-type: none"> • Circular • Grid • Radial • Star/Symmetric 	Comments:
Dimensionality	<ul style="list-style-type: none"> • 2D 	Comments:
Analysis		
Visual Abstraction	<ul style="list-style-type: none"> • Chart:Area • Chart:Bar • Chart:Line • Chart:Pie • Chart:Scatter • Chart:X-Y 	Comments: Charts are used for viewing performance data and alarms.
User Interaction		
User Interaction	<ul style="list-style-type: none"> • GUI • Pan • Select • Web/CGI • Zoom 	Comments:
Deployment		
	<p>Type:</p> <ul style="list-style-type: none"> • Components for tool building • Standalone Tool 	<p>OS:</p> <ul style="list-style-type: none"> • AIX • Linux • Solaris • UNIX • Windows • Windows 2000 • Windows NT • Windows XP
OS Comments/Dependencies	Redhat 8.0/9.0/ES/AS Solaris 2.8	
Extensibility	<ul style="list-style-type: none"> • JAVA • XML 	Comments: Many of the configuration files are written in XML providing easy customization.
Interoperability	Supported databases: Oracle, MySQL, MSSQL Server, TimesTen, Sybase ASA, Solid, Firebird	
Scalability	Max Nodes: 10,001-100,000 Max Links: Unknown	Comments:
	Hardware:	Users:
		Availability:

	<ul style="list-style-type: none"> • Multiple • Networked 	<ul style="list-style-type: none"> • Commercially Available
--	---	--

Cost	\$1001 - \$5000	Comments: Professional Edition - \$6000 Remote Management Edition - \$12000
-------------	-----------------	--

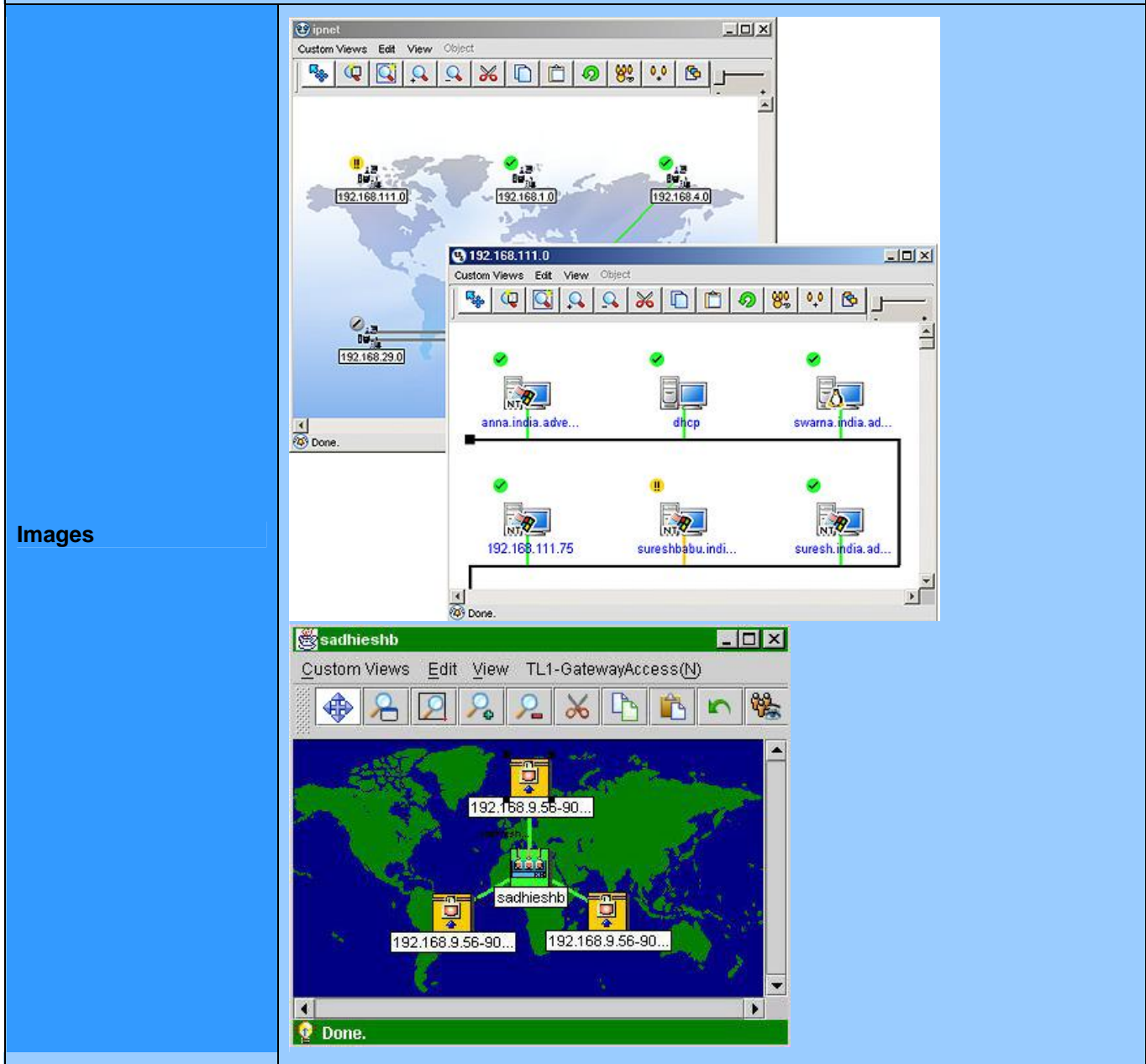

Last Modified	2006-12-18 19:30:32
----------------------	---------------------

Name	WhatsUp Professional Premium 2006
-------------	--

URL	http://www.ipswitch.com/products/whatsup/professional/index.asp	
Description	<p>Brief description: Discover and map your network, get notifications when problems occur, and receive reports on your network's performance.</p> <p>Detailed description:</p>	
Context		
Main Functionalities	<ul style="list-style-type: none"> Automated Layout Graph Manipulation Graph Viewing Network management/discovery 	Comments:
Domain	<ul style="list-style-type: none"> Computer Networks 	Comments:
	<p>User Role:</p>	<p>Activity:</p> <ul style="list-style-type: none"> Investigate Monitor Track
Network Representation		
Links	<ul style="list-style-type: none"> Labelled 	Comments:
Nodes	<ul style="list-style-type: none"> Labelled Symbol 	
Dimensionality	<ul style="list-style-type: none"> 2D 	Comments:
Analysis		
General Analysis	<ul style="list-style-type: none"> Trend Analysis 	Comments:
Network Analysis	<ul style="list-style-type: none"> Traffic Analysis 	Comments:
Visual Abstraction	<ul style="list-style-type: none"> Chart:Line Chart:Pie 	<p>Comments: Graphs of performance data are available. For example, WhatsUp Professional has five preconfigured performance reports:</p> <ul style="list-style-type: none"> * CPU Utilization * Memory Utilization * Interface Utilization (Bandwidth) * Ping Availability * Hard Disk Drive Utilization
User Interaction		
User Interaction	<ul style="list-style-type: none"> GUI Web/CGI 	<p>Comments: Through the Web Interface, you can remotely configure your network, just as if you were sitting at the WhatsUp Professional computer</p>

and using the console.

Deployment

Type:

- Standalone Tool

OS:

- Windows 2000
- Windows 2003
- Windows XP

OS Comments/Dependencies

Windows XP (SP1 or later)
Microsoft Internet Explorer 5.01 or greater
Microsoft Windows Scripting Host 5.6

Hardware:

Users:

- Multiple
- Networked

Availability:

- Commercially Available

Cost \$1001 - \$5000

Comments:

Images

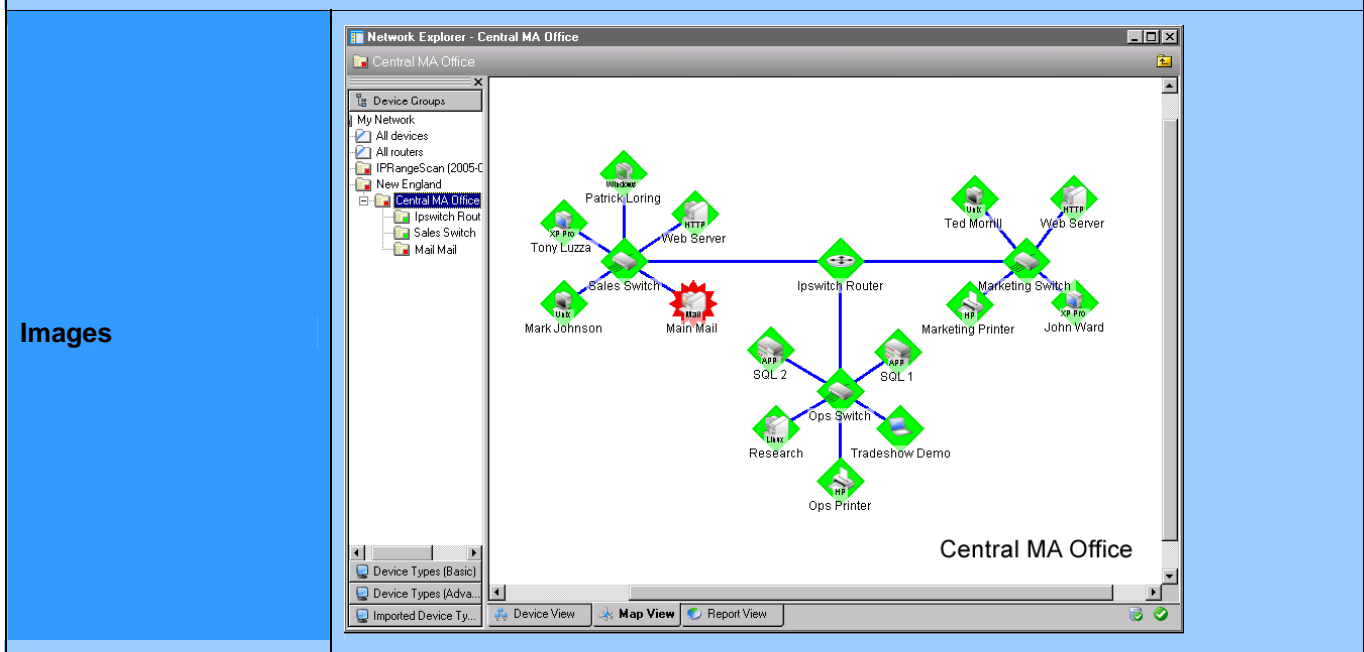

	<p>The screenshot shows a network management interface titled 'Network Explorer - Central MA Office'. On the left, a 'Device Groups' tree lists 'Central MA Office' with sub-items 'Server Room' and 'Wiring Closet'. The main area displays a floor plan of the 'Central MA Office Layout' with various rooms: STAIR, BREAK ROOM, MEN, WOMEN, CORRIDOR, WAITING ROOM, RECEPTION, ENTRANCE, and PORCH. Network devices are represented by icons: a red starburst for a switch in the Wiring Closet, green squares for servers in the Server Room, and green squares for PCs in the Finance and IT Admin areas. Blue lines indicate network connections between these devices. IP addresses like 156.21.3.33 and 156.21.3.46 are visible near some devices. The interface includes a 'Map View' button at the bottom.</p>
Last Modified	2006-12-18 19:30:52

Name	WilmaScope	
URL	http://www.wilmascope.org/	
Description	<p>Brief description: WilmaScope is a Java3D application which creates real time 3d animations of dynamic graph structures.</p> <p>Detailed description:</p>	
Product Version/Status	3.1 (2004-11-25)	
Context		
Main Functionalities	<ul style="list-style-type: none"> Automated Layout Graph Manipulation Graph Viewing Network Analysis 	Comments:
Domain	<ul style="list-style-type: none"> Any 	Comments:
Network Representation		
Type	<ul style="list-style-type: none"> Directed 	
Layout Algorithms	<ul style="list-style-type: none"> Clustered Force-Directed Spring 	Comments: The user has access to many layout algorithm parameters.
Dimensionality	<ul style="list-style-type: none"> 3D 	Comments:

Analysis		
Network Analysis	<ul style="list-style-type: none"> • Centrality:Betweenness • Centrality:Closeness • Centrality:Degree • Centrality:Eigenvector • Clustering • Connection:Cycle 	Comments:
User Interaction		
User Interaction	<ul style="list-style-type: none"> • Add/Delete • Drill down • GUI 	Comments: Wilma provides several tools for modifying the graph data (add/remove nodes, add to/remove from a cluster, collapse cluster, etc).
Deployment		
	<p>Type:</p> <ul style="list-style-type: none"> • Components for tool building • Open Source • Standalone Tool 	<p>OS:</p> <ul style="list-style-type: none"> • Multi-Platform (JAVA)
Extensibility	<ul style="list-style-type: none"> • JAVA 	Comments: New layout algorithms can be added as plugins by extending the WilmaScope LayoutEngine framework
Interoperability	File Formats: XML Wilma Graph (XWG) GML LEDA	
Cost	Free	Comments:

Images

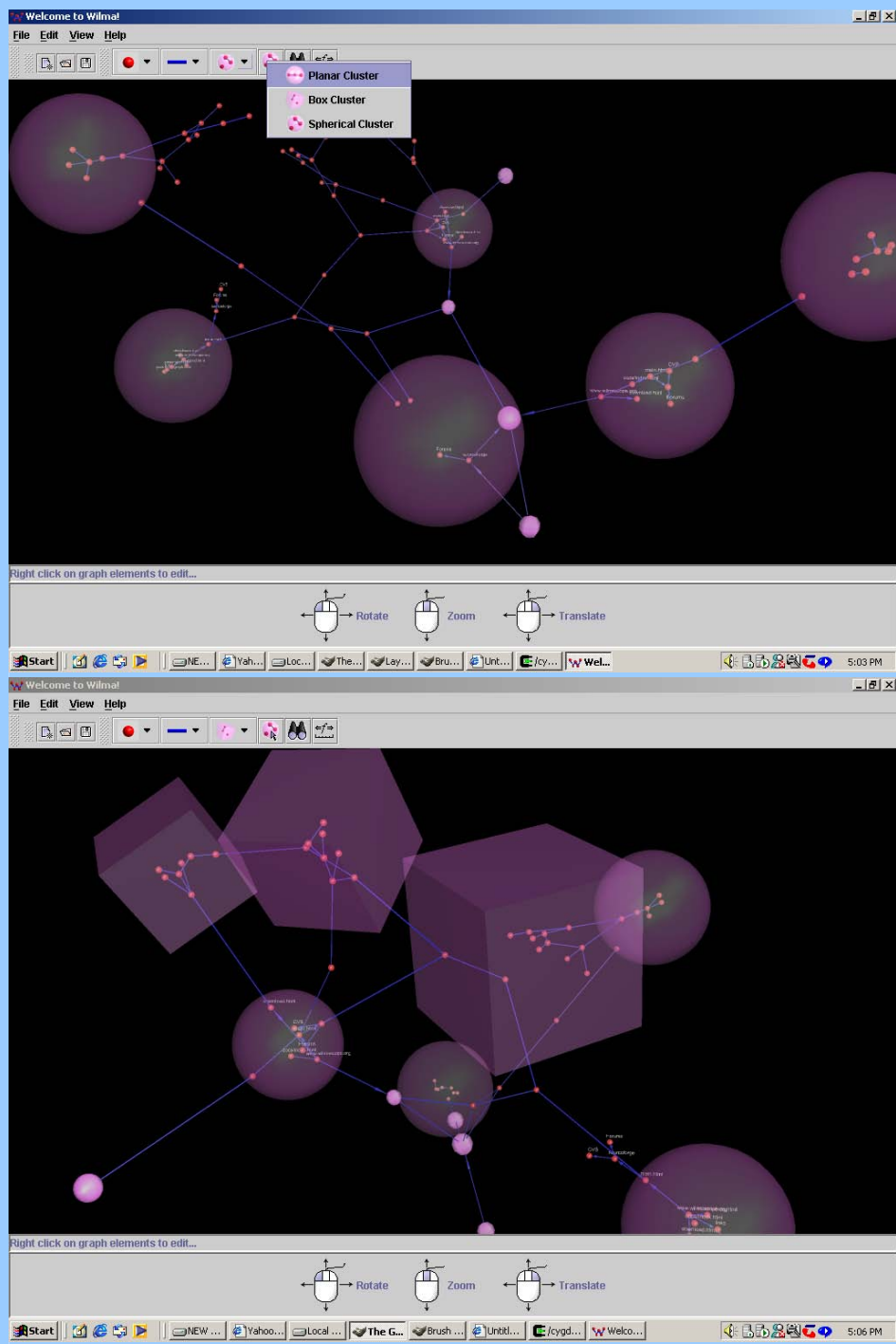

The screenshot displays the XGvis software interface. The main window shows a network graph with several nodes and edges. The nodes are represented by pink spheres of varying sizes, and the edges are thin blue lines. The graph is set against a dark background with some faint text like 'ga' and 'sequence'. To the right of the graph, there are two 'Force Controls' panels. The top panel has sliders for Spring, DirectedField, Origin, Repulsion, Planar, Velocity Scale, Balanced Threshold, and Iterations Per Frame. The bottom panel has sliders for Spring, DirectedField, Origin, Repulsion, Planar, Velocity Scale, Balanced Threshold, and Iterations Per Frame. Below the graph, there are three mouse icons labeled Rotate, Zoom, and Translate. The Windows taskbar is visible at the bottom, showing the Start button and several open applications. The system clock shows 4:18 PM.

Last Modified 2006-12-18 19:31:10

Name	XGvis
URL	http://www.research.att.com/areas/stat/xgobi/
Description	<p>Brief description: XGvis is an interactive visualization system for proximity data as well as for graphs and networks.</p> <p>Detailed description: Some XGvis FEATURES: <ul style="list-style-type: none"> * classical inner-product scaling (Torgerson-Gower), * distance scaling (Kruskal-Shepard), * nonmetric MDS with mixing of isotonic and identity transforms, * metric MDS with power transformations, * animation of MDS optimization, </p>

	<ul style="list-style-type: none"> * restarts from random configurations and random perturbations, * configurations in any dimension, * weights as a power function of the dissimilarities, * differential weights between/within groups of objects, * within/between/anchored MDS with regard to groups defined by colors and glyphs; special cases are multidimensional unfolding and external unfolding, * lower and upper trimming of dissimilarities, * random removal of dissimilarities for stability checks, * missing dissimilarity handling, * moving of configuration points with mouse dragging, * viewing of configurations with 3D rotations and grand tours, * linked views of covariates, * saving and printing of configurations, * XGobi window for Shepard diagram 	
Product Version/Status	April 2002	
Context		
Main Functionalities	<ul style="list-style-type: none"> • Automated Layout • Graph Manipulation • Graph Viewing 	Comments:
Domain	<ul style="list-style-type: none"> • Any 	Comments:
Network Representation		
Layout Algorithms	<ul style="list-style-type: none"> • MDS • MDS:Classical (Torgerson-Gower) • MDS:Metric (SVD) • MDS:Nonmetric (Kruskal) 	Comments:
Dimensionality	<ul style="list-style-type: none"> • 2D • 3D 	Comments:
Analysis		
General Analysis	<ul style="list-style-type: none"> • Shepard's Stress Plot 	Comments:
Visual Enhancements		
Visual Enhancements	<ul style="list-style-type: none"> • Animation/Video 	Comments:
User Interaction		
User Interaction	<ul style="list-style-type: none"> • GUI • Reposition 	Comments:
Deployment		
	Type: <ul style="list-style-type: none"> • Open Source 	OS:

OS Comments/Dependencies	uses XGobi as its VISUALIZATION ENGINE.	
	Hardware:	Users: Availability:
		<ul style="list-style-type: none"> • Research Prototype
Cost	Free - For noncommercial use	Comments:



Images

Last Modified	2006-12-18 19:31:26
----------------------	---------------------

Name	yFiles
URL	http://www.yworks.com/en/products_yfiles_about.htm
Description	<p>Brief description: yFiles is a Java class library that provides algorithms and components enabling the analysis, visualization, and the automatic layout of graphs, diagrams, and networks.</p> <p>Detailed description: yFiles functionality is divided into three parts - Basic, Viewer, and Layout.</p> <ul style="list-style-type: none"> • yFiles Basic contains essential classes and data types for graph analysis tasks. • yFiles Viewer, built upon the basic package, provides graph viewing and

	<p>user interface components. These components are showcased in the yED graph editor application. yFiles viewer also provides the ability to read and write various file formats.</p> <ul style="list-style-type: none"> • yFiles Layout, also built upon the basic package, offers a suite of graph layout algorithms, including hierarchic, orthogonal, and circular. <p>yFiles is also available as yFiles.NET for the microsoft .NET platform.</p>	
Product Version/Status	2.4.0.3	
Context		
Main Functionalities	<ul style="list-style-type: none"> • Automated Layout • Graph Manipulation • Graph Viewing • Network Analysis 	Comments:
Domain	<ul style="list-style-type: none"> • Any 	Comments:
Network Representation		
Links	<ul style="list-style-type: none"> • Coloured • Labelled • User Defined 	Comments:
Nodes	<ul style="list-style-type: none"> • Coloured • Labelled • Symbol • User Defined 	
Layout Algorithms	<ul style="list-style-type: none"> • Circular • Hierarchical • Incremental • Orthogonal • Spring • Tree 	<p>Comments: In addition to the layout algorithms, yFiles also provides the following edge algorithms: - Organic routing - Orthogonal routing</p> <p>Description of yFiles major layout algorithms: http://www.yworks.com/products/yfiles/doc/developers-guide/major_layouters.html</p>
Dimensionality	<ul style="list-style-type: none"> • 2D 	Comments:
Analysis		
Network Analysis	<ul style="list-style-type: none"> • Centrality:Closeness • Centrality:Degree • Centrality:Edge Betweenness • Centrality:Node Betweenness • Centrality:Weight • Clustering • Connection:Accessibility • Connection:Connectivity 	Comments:

	<ul style="list-style-type: none"> Connection:Cycle Connection:Flow Connection:Max. Flow Connection:Path Connection:Shortest Path Graph Structure Traversal:Breadth First Search Traversal:Depth First Search 	
--	---	--

Visual Enhancements

<u>Visual Enhancements</u>	<ul style="list-style-type: none"> Animation/Video 	Comments:
----------------------------	---	------------------

Deployment

	<p><u>Type:</u></p> <ul style="list-style-type: none"> Components for tool building 	<p><u>OS:</u></p> <ul style="list-style-type: none"> Multi-Platform (JAVA) Windows
--	--	--

<u>Extensibility</u>	<ul style="list-style-type: none"> .NET JAVA 	Comments:
----------------------	--	------------------

<u>Interoperability</u>	Extention packages are available for yFiles that provide support for the following files formats: GraphML SVG WMF	
-------------------------	--	--

	<p><u>Hardware:</u></p>	<p><u>Users:</u></p>	<p><u>Availability:</u></p> <ul style="list-style-type: none"> Commercially Available In Use
--	-------------------------	----------------------	--

<u>Cost</u>	Complicated - See Comments	Comments:					
		License type	Package(pricesinUS\$)				
			2,340	4,680	4,680	6,240	3,900
			700	1,400	1,400	1,870	1,170
			7,800	16,900	16,900	23,400	14,100
			2,340	5,070	5,070	7,020	4,230
			8,320	17,680	17,680	24,960	14,900
			2,490	5,300	5,300	7,480	4,420
			15,600	32,760	32,760	46,800	32,760
			4,680	9,820	9,820	14,040	9,820

Visual Enhancements

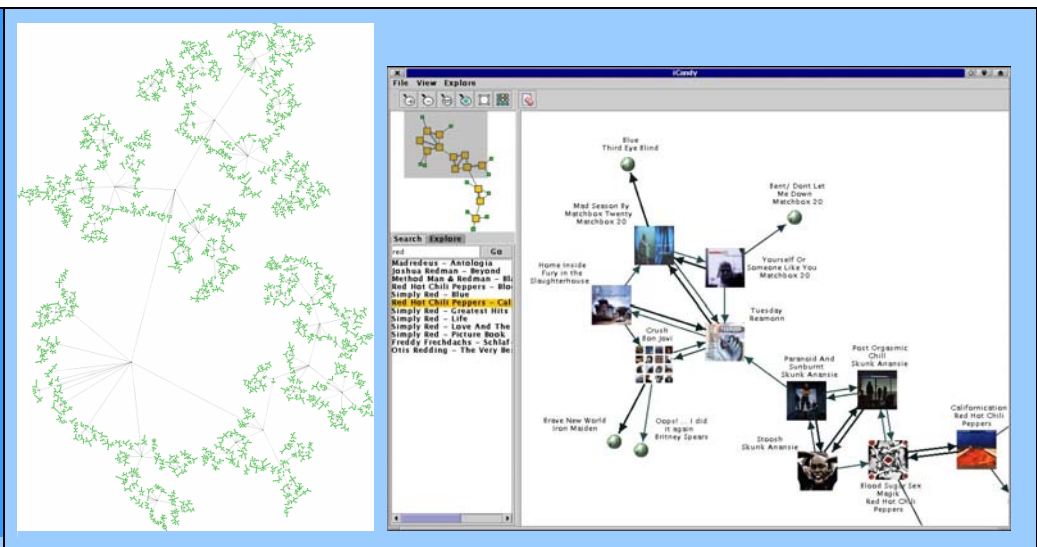
<p>Images</p>	
<p>References</p>	<p>API Documentation http://www.yworks.com/products/yfiles/doc/api/index.html</p>
<p>Last Modified</p>	<p>2006-12-18 22:58:09</p>

<p>Name</p>	<p>Zest: The Eclipse Visualization Toolkit</p>	
<p>URL</p>	<p>http://www.eclipse.org/mylar/zest.php</p>	
<p>Description</p>	<p>Brief description: Zest is visualization toolkit for Eclipse. The primary goal of Zest is to simplify graph based programming</p> <p>Detailed description: Zest: The Eclipse Visualization Toolkit, is a set of visualization components built for Eclipse. Zest is a component of the Mylar project that can be used independently of the Mylar IDE support. The entire Zest library has been developed in SWT and integrates seamlessly within Eclipse because of its recognized design.</p>	
<p>Context</p>		
<p>Main Functionalities</p>	<ul style="list-style-type: none"> Automated Layout Graph Manipulation Graph Viewing 	<p>Comments:</p>
<p>Domain</p>	<ul style="list-style-type: none"> Any 	<p>Comments:</p>
<p>Network Representation</p>		
<p>Layout Algorithms</p>	<ul style="list-style-type: none"> Grid Radial Spring Tree 	<p>Comments:</p>
<p>Dimensionality</p>	<ul style="list-style-type: none"> 2D 	<p>Comments:</p>

Deployment		
	Type: <ul style="list-style-type: none"> Open Source 	OS: <ul style="list-style-type: none"> Multi-Platform (JAVA)
Extensibility	<ul style="list-style-type: none"> JAVA 	Comments: Zest library has been developed in SWT
	Hardware:	Users:
		Availability: <ul style="list-style-type: none"> Freeware
Cost	Free	Comments: Eclipse is released under the Eclipse Public License (EPL) http://www.eclipse.org/legal/eplfaq.php

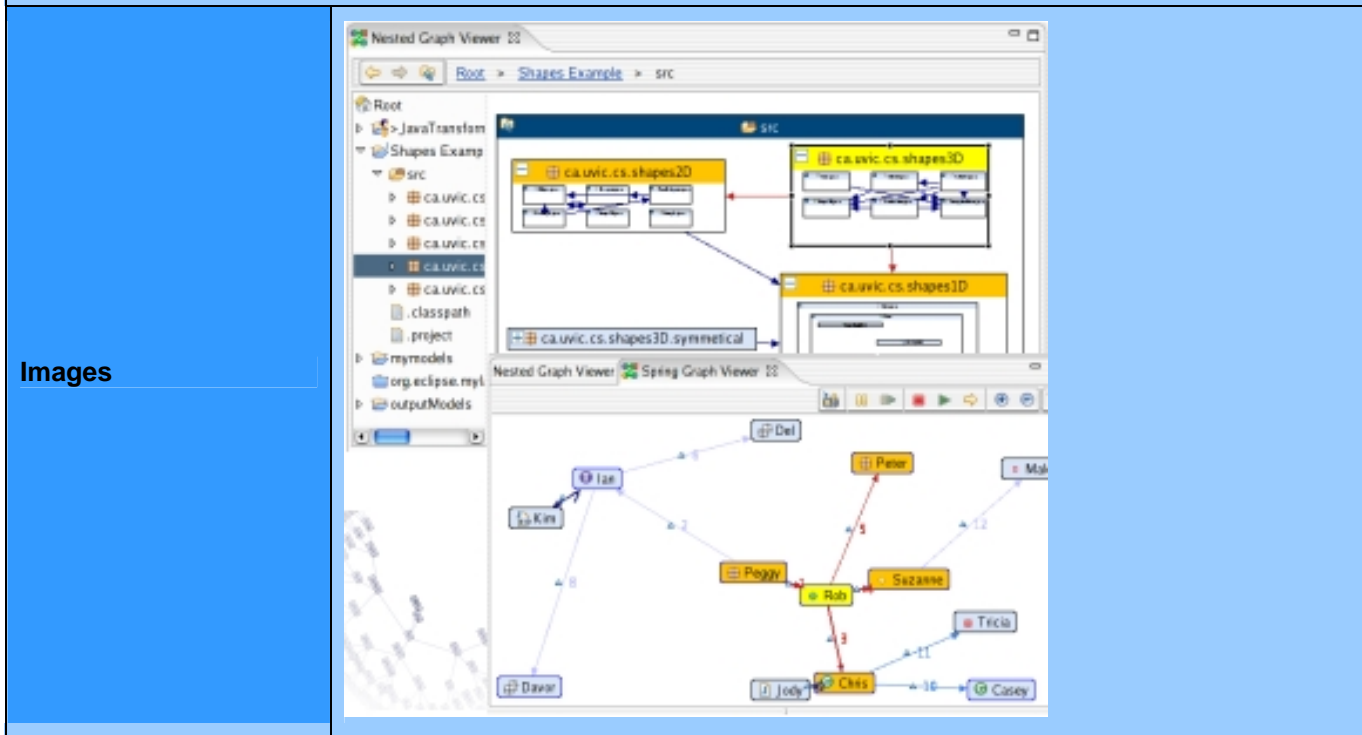

Last Modified	2006-12-10 16:39:16
----------------------	---------------------

Literature Survey

1. S. Feiner, M. Zhou, L. Crutcher, and A.A. Lazar, "A Virtual World for Network Management", 1993 Virtual Reality Annual International Symposium (VRAIS '93), IEEE, 18-22 Sep 1993, pages 55 - 61.
Existing network management systems typically use a combination of textual displays and 2D directed graph representations of network topology. We are designing a network management system that instead uses a virtual world presented through a 3D stereo display and manipulated with a 3D mouse. Our goal is to allow the user to better understand and control the structure and behavior of a large, complex network. In our current prototype, the user interacts with a 3D representation of a network whose topology and behavior is specified by a separate network emulator. The user can choose from among a set of different views of the network. For example, one view shows a selected virtual path as a series of logical links contained within a physical path. The system will ultimately serve as a testbed for the knowledge-based design of network visualizations.
2. Fuji, H.; Nakai, S.; Matoba, H.; Takano, H., "Real-time Bifocal Network-Visualization", Network Operations and Management Symposium, 1994, IEEE Volume 3, 14-17 Feb 1994, pages 867 - 876
Although most current management systems employ graphic-user-interface displays to visualize the networks being managed, this approach is rather difficult to apply to extremely large-size networks (e.g. those with hundreds of complexly connected devices) since the full picture cannot easily be presented within the limited display space available. The conventional tactic employed to avoid this problem, hierarchical multi-window presentation, has disadvantages of its own, e.g. the complexity of the operations required to move among separate windows, etc. In this paper, we describe an approach to visualizing networks which uses a bifocal display capable of displaying both context and local details simultaneously within a single window and without the loss of information that overlapping windows would produce. We implemented the bifocal network visualization system on a workstation using a frame-buffer memory for real-time image generation, and with the aid of an event simulation program, we were able to operate our proposed system experimentally and confirm the effectiveness of bifocal network visualization.
3. Alexander Gubin and William Yurcik and Larry Brumbaugh , "Network Management Visualization With PingTV", IEEE LCN'00, Los Alamos, CA, page 62.
PingTV is used at Illinois State University as a visualization tool to communicate real-time network conditions to the university community via a dedicated channel on the campus cable TV system. Colored symbols allow students and staff to discern high-congestion "rush hours" and understand why their specific Internet connectivity is "broken" from the wide range of potential causes.
4. Gubin, A.; Yurcik, W.; Brumbaugh, L., "PingTV: A Case Study in Visual Network Monitoring", Visualization, 2001. VIS'01. Proceedings, 21-26 Oct. 2001, pages 421 - 580
PingTV generates a logical map of a network that is used as an overlay on a physical geographical image of the location from the user perspective (buildings, floors within buildings, etc.). PingTV is used at Illinois State University as a visualization tool to communicate real-time network conditions to the university community via a dedicated channel on the campus cable TV system. Colored symbols allow students and staff to discern high congestion "rush hours" and understand why their specific Internet connectivity is "broken" from the wide range of potential causes.

Lessons learned include the use of color to visually convey confidence intervals using color shading and the visualization of cyclical network traffic patterns. Our implementation is general and flexible with potential for application for other domains.

5. Nyarko, K.; Capers, T.; Scott, C.; Ladeji-Osias, K., “Network Intrusion Visualization with NIVA, an Intrusion Detection Visual Analyzer with Haptic Integration”, Haptic Interfaces for Virtual Environment and Teleoperator Systems, 2002. HAPTICS 2002. Proceedings. 10th Symposium on, 2002 Page(s):277 - 284

The explosive growth of malicious activities on worldwide communication networks, such as the Internet, has highlighted the need for efficient intrusion detection systems. The efficiency of traditional intrusion detection systems is limited by their inability to effectively relay relevant information due to their lack of interactive/immersive technologies. In this paper, we explore several network visualization techniques geared towards intrusion detection on small and large-scale networks. We also examine the use of haptics in network intrusion visualization. By incorporating concepts from electromagnetics, fluid dynamics, and gravitational theory, we show that haptic technologies can provide another dimension of information critical to the efficient visualization of network intrusion data. Furthermore, we explore the applicability of these visualization techniques in conjunction with commercial network intrusion detectors. Finally, we present a network intrusion visualization application with haptic integration, NIVA, which allows the analyst to interactively investigate as well as efficiently detect structured attacks across time and space using advanced interactive three-dimensional displays.

6. Chaomei Chen; Morris, S., “Visualizing Evolving Networks: Minimum Spanning Trees versus Pathfinder Networks”, Information Visualization, 2003. INFOVIS 2003. IEEE Symposium on, 19-21 Oct. 2003 Page(s): 67 - 74

Network evolution is a ubiquitous phenomenon in a wide variety of complex systems. There is an increasing interest in statistically modeling the evolution of complex networks such as small-world networks and scale-free networks. In this article, we address a practical issue concerning the visualization of network evolution. We compare the visualizations of co-citation networks of scientific publications derived by two widely known link reduction algorithms, namely minimum spanning trees (MSTs) and Pathfinder networks (PFNETs). Our primary goal is to identify the strengths and weaknesses of the two methods in fulfilling the need for visualizing evolving networks. Two criteria are derived for assessing visualizations of evolving networks in terms of topological properties and dynamical properties. We examine the animated visualization models of the evolution of botulinum toxin research in terms of its co-citation structure across a 58-year span (1945-2002). The results suggest that although high-degree nodes dominate the structure of MST models, such structures can be inadequate in depicting the essence of how the network evolves because MST removes potentially significant links from high-order shortest paths. In contrast, PFNET models clearly demonstrate their superiority in maintaining the cohesiveness of some of the most pivotal paths, which in turn make the growth animation more predictable and interpretable. We suggest that the design of visualization and modeling tools for network evolution should take the cohesiveness of critical paths into account.

7. Chan, D.S.-M.; Khim Shiong Chua; Leckie, C.; Parhar, A., “Visualisation of Power-Law Network Topologies”, Networks, 2003. ICON2003. The 11th IEEE International Conference on, 28 Sept.-1 Oct. 2003 Page(s): 69 - 74

We present a novel graph layout algorithm called ODL for visualising large network topologies. The main contribution of our algorithm is to simplify the layout problem by separating the nodes in

the network into multiple hierarchical layers based on the outdegree of each node. Our algorithm is designed to exploit the underlying structure of power-law topologies, which occur in a wide variety of practical network applications. However, the use of our algorithms is not limited to this class of networks. We have demonstrated that our algorithm can generate useful and aesthetically pleasing layouts for a wide variety of networks, including both regular and power-law topologies. In particular, OUT algorithm achieved substantial performance improvements over existing layout techniques, including a speed-up factor of up to 260 on real-life Internet routing topologies.

8. Ishmael, J.; Race, N.J.P., “Visawin : Visualising a Wireless Network”, Vehicular Technology Conference, 2004. VTC 2004-Spring, Volume 5, 17-19 May 2004 Page(s): 2623 - 2626
Recent years have seen the evolution and subsequent deployment of wireless networking; providing network access to mobile users in many diverse locations. However, the very characteristics of wireless technology means that access to wireless resources can sometimes be sporadic. A lack of signal or interference from other devices can cause a user’s interactions with a network to fail. Currently there are very few integrated solutions available which provide both network engineers and end users with information regarding the coverage of a wireless network. This paper describes Visawin, an automated system which visualizes a wireless network; allowing for both improved wireless engineering and user operability. The paper presents the challenges involved in developing Visawin, as well as results demonstrating that the system is useful for both end users and engineers when planning and designing networks.
9. Najeeb, Z.; Nazir, F.; Haider, S.; Suguri, H.; Ahmad, H.F.; Ali, A., “An Intelligent Self-Learning Algorithm for IP Network Topology Discovery”, Local and Metropolitan Area Networks, 2005. LANMAN 2005. The 14th IEEE Workshop on, Volume , Issue , 18-21 Sept. 2005, 6 pages.
The significance of network topology discovery cannot be denied, especially for tasks like network management, network analysis or network visualization. In this paper we describe a novel topology discovery algorithm which is intelligent, efficient and self-learning. Sending ICMP requests to inactive hosts can waste considerable amount of time in the discovery process. We propose an algorithm that queries hosts having higher probability of being active. Our algorithm is selflearning in the sense that it can learn and decide for itself which ranges of IP addresses to send ICMP echo requests that would yield quick initial response. Our algorithm does not entirely rely on SNMP-MIB or ICMP echo request/reply, DNS, Trace route etc, rather SNMP is installed only on routers, switches and network printers. We have implemented and tested the algorithm at NUST Institute of Information Technology, Pakistan and it has accurately discovered the network topology.
10. Livnat, Y.; Agutter, J.; Shaun Moon; Foresti, S., “Visual Correlation for Situational Awareness”, Information Visualization, 2005. INFOVIS 2005. IEEE Symposium on, 23-25 Oct. 2005 Pages 95 - 102
We present a novel visual correlation paradigm for situational awareness (SA) and suggest its usage in a diverse set of applications that require a high level of SA. Our approach is based on a concise and scalable representation, which leads to a flexible visualization tool that is both clear and intuitive to use. Situational awareness is the continuous extraction of environmental information, its integration with previous knowledge to form a coherent mental picture, and the use of that picture in anticipating future events.
In this paper we build on our previous work on visualization for network intrusion detection and show how that approach can be generalized to encompass a much broader class of SA systems. We first propose a generalization that is based on what we term, the w3premise, namely that each

event must have have at least the What, When and Where attributes. We also present a second generalization, which increases flexibility and facilitates complex visual correlations. Finally, we demonstrate the generality of our approaches by applying our visualization paradigm in a collection of diverse SA areas.

11. Wei Yuan; Changxing Pei; Haiyun Xiao; Changhua Zhu; Nan Chen; Yun-hui Yi, “Study on Network Topology Visualization Algorithm and Implement Based on A* Algorithm”, Parallel and Distributed Computing, Applications and Technologies, 2005. PDCAT 2005. Sixth International Conference on, 05-08 Dec. 2005 Page(s): 154 - 157
This paper presents a network topology visualization algorithm based on A algorithm. This algorithm is not only very universally applicable which can improve greatly the speed of operation and save the memory and meet the real-time requirement of network topology visualization, but also solve the problem of loop caused by single topology visualization algorithm, therefore, it's preferably suitable for the research on complicated network topology.*
12. Arvanitis, T.N.; Constantinou, C.C.; Stepanenko, A.S.; Sun, Y.; Liu, B.; Baughan, K., “Network visualisation and analysis tool based on logical network abridgment”, Military Communications Conference, 2005. MILCOM 2005. IEEE, 17-20 Oct. 2005 Pages: 106 - 112 Vol. 1
A novel procedure of summarizing and abstracting the topology and distributed statistical measures of routing performance for communication networks is presented. This procedure, called Logical Network Abridgment (LNA), forms the basis of a novel Resilient Recursive Routing (R3) protocol. In this paper, we investigate the usefulness of LNA in visualizing and defining the state of health of a communication network. Traditionally, connectivity and metrics (such as link utilization, end-to-end delay, etc.) are used to provide indications of the state of health of a network. However, connectivity alone tells us little about the intrinsic diversity of the network and therefore its resiliency to attacks or attrition. Similarly, individual localized or path specific metrics tell us little about the overall intrinsic capability of the network. The LNA procedure summarizes the metric of choice over the total network and is thus capable of describing the intrinsic state of its health. In the context of military command and control, as well as commercial network management, scenarios, operators wish to easily create well-designed networks, in terms of resiliency and performance. Furthermore, operators need to identify, in an intuitive manner, the vulnerabilities that exist in a network. In addition, the consequences of actions taken to remedy failures or strengthen resiliency are often time consuming to understand in a large distributed system. The LNA procedure offers a quick and reliable algorithmic visual tool to achieve these. The paper will present work funded by the US Air-Force Research Laboratory (AFRL-EOARD) that demonstrates the potential of network visualization and analysis through the proposed LNA procedure.
13. Lad, M.; Massey, D.; Zhang, L., “Visualizing Internet Routing Changes”, Transactions on Visualization and Computer Graphics, Nov.-Dec. 2006, Volume 12, Issue 6, pages 1450-1460
Today's Internet provides a global data delivery service to millions of end users and routing protocols play a critical role in this service. It is important to be able to identify and diagnose any problems occurring in Internet routing. However, the Internet's sheer size makes this task difficult. One cannot easily extract out the most important or relevant routing information from the large amounts of data collected from multiple routers. To tackle this problem, we have developed Link-Rank, a tool to visualize Internet routing changes at the global scale. Link-Rank weighs links in a topological graph by the number of routes carried over each link and visually captures changes in link weights in the form of a topological graph with adjustable size. Using Link-Rank, network

operators can easily observe important routing changes from massive amounts of routing data, discover otherwise unnoticed routing problems, understand the impact of topological events, and infer root causes of observed routing changes.

14. Yarden Livnat; Agutter, J.; Moon, S.; Erbacher, R.F.; Foresti, S., "A Visualization Paradigm for Network Intrusion Detection", Information Assurance Workshop, 2005. IAW apos;05. Proceedings from the Sixth Annual IEEE SMC, 15-17 June 2005 Page(s): 92 - 99
We present a novel paradigm for visual correlation of network alerts from disparate logs. This paradigm facilitates and promotes situational awareness in complex network environments. Our approach is based on the notion that, by definition, an alert must possess three attributes, namely: What, When, and Where. This fundamental premise, which we term w3, provides a vehicle for comparing between seemingly disparate events. We propose a concise and scalable representation of these three attributes that leads to a flexible visualization tool that is also clear and intuitive to use. Within our system, alerts can be grouped and viewed hierarchically with respect to both their type, i.e., the What, and to their Where attributes. Further understanding is gained by displaying the temporal distribution of alerts to reveal complex attack trends. Finally, we propose a set of visual metaphor extensions that augment the proposed paradigm and enhance users' situational awareness. These metaphors direct the attention of users to many-to-one correlations within the current display helping them detect abnormal network activity.
15. Abello, J.; van Ham, F.; Krishnan, N., "ASK-GraphView : A Large Scale Graph Visualization System", Transactions on Visualization and Computer Graphics, Sept.-Oct. 2006, Volume 12, Issue 5, pages 669-676
We describe ASK-GraphView, a node-link-based graph visualization system that allows clustering and interactive navigation of large graphs, ranging in size up to 16 million edges. The system uses a scalable architecture and a series of increasingly sophisticated clustering algorithms to construct a hierarchy on an arbitrary, weighted undirected input graph. By lowering the interactivity requirements we can scale to substantially bigger graphs. The user is allowed to navigate this hierarchy in a top down manner by interactively expanding individual clusters. ASK-GraphView also provides facilities for filtering and coloring, annotation and cluster labeling.
16. Kumar, G.; Garland, M., "Visual Exploration of Complex Time-Varying Graphs", IEEE Transactions on Visualization and Computer Graphics archive, Volume 12, Issue 5 (September 2006), Pages: 805-812
Many graph drawing and visualization algorithms, such as force-directed layout and line-dot rendering, work very well on relatively small and sparse graphs. However, they often produce extremely tangled results and exhibit impractical running times for highly non-planar graphs with large edge density. And very few graph layout algorithms support dynamic time-varying graphs; applying them independently to each frame produces distracting temporally incoherent visualizations. We have developed a new visualization technique based on a novel approach to hierarchically structuring dense graphs via stratification. Using this structure, we formulate a hierarchical force-directed layout algorithm that is both efficient and produces quality graph layouts. The stratification of the graph also allows us to present views of the data that abstract away many small details of its structure. Rather than displaying all edges and nodes at once, resulting in a convoluted rendering, we present an interactive tool that filters edges and nodes using the graph hierarchy and allows users to drill down into the graph for details. Our layout algorithm also accommodates time-varying graphs in a natural way, producing a temporally coherent animation that can be used to analyze and extract trends from dynamic graph data. For

example, we demonstrate the use of our method to explore financial correlation data for the U.S. stock market in the period from 1990 to 2005. The user can easily analyze the time-varying correlation graph of the market, uncovering information such as market sector trends, representative stocks for portfolio construction, and the interrelationship of stocks over time.

17. Henry, N.; Fekete, J.-D., “MatrixExplorer: a Dual-Representation System to Explore Social Networks”, Transactions on Visualization and Computer Graphics, Sept.-Oct. 2006, Volume 12, Issue 5, pages 677-684
MatrixExplorer is a network visualization system that uses two representations: node-link diagrams and matrices. Its design comes from a list of requirements formalized after several interviews and a participatory design session conducted with social science researchers. Although matrices are commonly used in social networks analysis, very few systems support the matrix-based representations to visualize and analyze networks. MatrixExplorer provides several novel features to support the exploration of social networks with a matrix-based representation, in addition to the standard interactive filtering and clustering functions. It provides tools to reorder (layout) matrices, to annotate and compare findings across different layouts and find consensus among several clusterings. MatrixExplorer also supports Node-link diagram views which are familiar to most users and remain a convenient way to publish or communicate exploration results. Matrix and node-link representations are kept synchronized at all stages of the exploration process.
18. Hans-Jorg Schulz and Heidrun Schumann , “Visualizing Graphs - A Generalized View”, IV '06: Proceedings of the conference on Information Visualization, 2006, pages 166-173, Washington, DC, USA
The visualization of graphs has proven to be very useful for exploring structures in different application domains. However, in certain fields of computer science, graph visualization is understood and focused quite differently. While ”graph drawing” focuses on optimized layouts for nodelink-representations of networks, ”information visualization” prefers to work on hierarchies focusing on very large structures, different views and interactivity. This paper gives a systematic view of the problem of graph visualization by combining both approaches. We will introduce a general view of different visualization methods as well as describe occurring problems and discuss basic constraints. These will be used to propose a visualization framework for graphs, whose development motivated this paper.
19. J. Tolle and O. Niggemann, “Supporting intrusion detection by graph clustering and graph drawing”, In Proceedings of the Third International Workshop on Recent Advances in Intrusion Detection (RAID 2000).
This paper presents a description of a system supporting the detection of intrusions and network anomalies by analyzing and visualising traffic flows in computer networks. The system supervises the typical communication structure in the network and acts as an anomaly detection component of an Intrusion Detection System. Events are generated in the case of sudden variations of the traffic structure. Visualization of the traffic structure is used to help the security manager to gain an overview on the current traffic structure and to help identifying the type and the location of network anomalies.
20. Hui Tian, “Network Topology Discovery and Its Applications”, Ph.D. Thesis, School of Information Science, Japan Advanced Institute of Science and Technology, March 2006.
Available online at <http://www.jaist.ac.jp/library/thesis/is-doctor-2006/paper/hui-t/paper.pdf>.

21. Hal Burch, "Measuring an IP Network in situ", Ph.D. Thesis, Carnegie Mellon University, Pittsburgh, PA, USA, 2005.
The Internet, and IP networking in general, have become vital to the scientific community and the global economy. This growth has increased the importance of measuring and monitoring the Internet to ensure that it runs smoothly and to aid the design of future protocols and networks. To simplify network growth, IP networking is designed to be decentralized. This means that each router and each network needs and has only limited information about the Internet. One disadvantage of this design is that measurement systems are required in order to determine the behavior of the Internet as a whole. This thesis explores ways to measure five different aspects of the Internet. The first aspect considered is the Internet's topology, the inter-connectivity of the Internet. This is one of the basic questions about the Internet: what hosts are on the Internet and how are they connected? The second aspect is routing: what are the routing decisions made by routers for a particular destination? The third aspect is locating the source of a denial-of-service (DoS) attack. DoS attacks are problematic to locate because their source is not listed in the packets. Thus, special techniques are required. The fourth aspect is link delays. This includes both a general system to determine link delays from end-to-end measurements and a specific system to perform end-to-end measurements from a single measurement host. The fifth aspect is the behavior of filtering on the network. Starting about fifteen years ago, to increase security, corporations started placing filtering devices, i.e., "firewalls", between their corporate network and the rest of the Internet. For each aspect, a measurement system is described and analyzed, and results from the Internet are presented.

22. Truong, Quoc Dinh and Dkaki, Taoufiq, "ViAGraph : a Tool for Graph Visualization and Analysis". In Proceedings International Workshop on Webometrics, Informetrics and Scientometrics & Seventh COLLNET Meeting, Nancy (France, 2006).
Graphs are common representations that can capture the structure and then can model a wide range of data and knowledge. In this paper, we present and discuss the functionalities of ViAGraph a tool for graph visualization and analysis. ViAGraph is meant to assist the user in exploring raw information in order to unveil interesting and useful information thru both query/answer and interactively guided data examination interactions. The paper presents a bunch of ideas and techniques related to graph visualization and exploration. Our main contributions are: 1. We propose a new approach of node placement based on 'geographic' constraints. 2. We discuss a novel analysis method based on graph comparison. Strengths and weaknesses of the proposed methods are discussed.

23. Daniel Archambault, Tamara Munzner, and David Auber. "Topolayout: Graph layout by topological features". In INFOVIS '05: Poster Track of the IEEE Symposium on Information Visualization (INFOVIS'05), pages 3-4, Washington, DC, USA, 2005. IEEE Computer Society.
We describe a new multi-level algorithm to draw graphs based on the topological features they contain. Topological features are recursively detected and their subgraphs are collapsed into single nodes, forming a graph hierarchy. Once the hierarchy is computed, we draw the subgraphs of the hierarchy, using an appropriate algorithm for each topological feature. Our layout algorithms are areaaware: the space required to draw a topological feature is taken into account when the node representing that feature is drawn at a higher level of the hierarchy. Unlike previous work, TopoLayout can be geared to graphs that contain specific topological features to produce layouts that emphasize those features without asymptotic or empirical runtime penalty.

24. Auber, D.; Chiricota, Y.; Jourdan, F.; Melancon, G., “Multiscale Visualization of Small World Networks”, Information Visualization, 2003. INFOVIS 2003. IEEE Symposium on, 19-21 Oct. 2003 Page(s): 75 - 81

Many networks under study in Information Visualization are “small world” networks. These networks first appeared in the study social networks and were shown to be relevant models in other application domains such as software reverse engineering and biology. Furthermore, many of these networks actually have a multiscale nature: they can be viewed as a network of groups that are themselves small world networks. We describe a metric that has been designed in order to identify the weakest edges in a small world network leading to an easy and low cost filtering procedure that breaks up a graph into smaller and highly connected components. We show how this metric can be exploited through an interactive navigation of the network based on semantic zooming. Once the network is decomposed into a hierarchy of sub-networks, a user can easily find groups and subgroups of actors and understand their dynamics.

25. Richard Zschech, “Computer Network Visualisation”, Adelaide University Honours thesis, October 2000.

Computer networks and especially the Internet are by their very nature tremendously complicated. This is because networks include many hosts and connections between them. Computer visualisation techniques offer the opportunity to display complicated sets of information in an easy to view and easy to understand manner. This thesis examines methods for mapping computer networks and visualising the results. This project involved implementation of a generic three-dimensional graphing package. The package contains many different techniques for laying out the graphs in an easy to visualise pattern. Good layout methods are needed to facilitate people’s understanding of the visualisation application. The resulting graphs were rendered in three-dimensions using Java3D. The user is able to view and interact with the graphs in real time. One application of visualisation methods is the mapping of computer networks and the collection of statistics about them. This project used the Simple Network Management Protocol to query the required information from the network and used it to build the graphs.

26. Dwyer, T.; Koren, Y., “DIG-COLA: Directed Graph Layout through Constrained Energy Minimization”, Information Visualization, 2005. INFOVIS 2005. IEEE Symposium on, 23-25 Oct. 2005, page(s): 65- 72

We describe a new method for visualization of directed graphs. The method combines constraint programming techniques with a high performance force-directed placement (FDP) algorithm so that the directed nature of the graph is highlighted while useful properties of FDP — such as emphasis of symmetries and preservation of proximity relations—are retained. Our algorithm automatically identifies those parts of the digraph that contain hierarchical information and draws them accordingly. Additionally, those parts that do not contain hierarchy are drawn at the same quality expected from a non-hierarchical, undirected layout algorithm. An interesting application of our algorithm is directional multidimensional scaling (DMDS). DMDS deals with low-dimensional embedding of multivariate data where we want to emphasize the overall flow in the data (e.g. chronological progress) along one of the axes.

27. Julia Ferraioli, “User-Guided Interactive Graph Layout”, (Online)

http://www.cra.org/Activities/craw/dmp/awards/2005/Ferraioli/final_report.pdf (2005)

Current graph visualization techniques gather information found in a database or a file and create output on the screen that represents that data. There are different types of layouts from which to choose, such as force-directed layouts, circle-layouts and spring layouts. These layouts are all

either random, or based upon the edges in the graphs. They do not lend any weight to what the nodes might represent. By making the graph interactive, thereby allowing the user to manipulate the graph, the graph slowly develops into the organization which the user intends. However, with this method, the user would have to rearrange every node in order to accomplish the intended arrangement. This is inefficient and frustrating to the user.

*If we incorporate the attributes into the arrangement of the nodes, we should be able to arrive at the correct arrangement much faster than without taking the attributes into account. This may be accomplished by various means, but the two that we considered for this research are simple clustering and constrained clustering. Just performing simple clustering, by using an algorithm such as *k*-Means, does allow the graph to take attributes into consideration, but does not allow user feedback. By employing an algorithm such as COP-KMeans or PCKMeans, we take both attributes and user feedback and use them to arrange the on-screen graph. We propose that combining a user-friendly interface with some type of constrained clustering will allow the user to arrive at the desired graph in a significantly shorter amount of time.*

Distribution list

Document No.: DRDC Ottawa CR 2007-280

LIST PART 1: Internal Distribution by Centre

- 2 DRDC Ottawa Library
- 1 Marc Grégoire, NIO/DRDC Ottawa, electronic copy
- 1 J. Treurniet
- 4 TOTAL LIST PART 1

LIST PART 2: External Distribution by DRDKIM

- 1 Director R&D Knowledge and Information Management, electronic copy
- 1
- 1 TOTAL LIST PART 2

5 TOTAL COPIES REQUIRED

This page intentionally left blank.

UNCLASSIFIED

SECURITY CLASSIFICATION OF FORM
(highest classification of Title, Abstract, Keywords)

DOCUMENT CONTROL DATA

(Security classification of title, body of abstract and indexing annotation must be entered when the overall document is classified)

1. ORIGINATOR (the name and address of the organization preparing the document. Organizations for whom the document was prepared, e.g. Establishment sponsoring a contractor's report, or tasking agency, are entered in section 8.) NRNS Inc. 4043 Carling Avenue, Suite 106. Ottawa, Ontario, Canada, K2K 2A3		2. SECURITY CLASSIFICATION (overall security classification of the document, including special warning terms if applicable) UNCLASSIFIED	
3. TITLE (the complete document title as indicated on the title page. Its classification should be indicated by the appropriate abbreviation (S,C or U) in parentheses after the title.) Survey of Network Visualization Tools (U)			
4. AUTHORS (Last name, first name, middle initial) Gort, Adam and Gort, James			
5. DATE OF PUBLICATION (month and year of publication of document) December 2007		6a. NO. OF PAGES (total containing information. Include Annexes, Appendices, etc.) 268	6b. NO. OF REFS (total cited in document) 0
7. DESCRIPTIVE NOTES (the category of the document, e.g. technical report, technical note or memorandum. If appropriate, enter the type of report, e.g. interim, progress, summary, annual or final. Give the inclusive dates when a specific reporting period is covered.) Contractor Report			
8. SPONSORING ACTIVITY (the name of the department project office or laboratory sponsoring the research and development. Include the address.) DRDC Ottawa 3701 Carling Ave. Ottawa, ON K1A 0Z4			
9a. PROJECT OR GRANT NO. (if appropriate, the applicable research and development project or grant number under which the document was written. Please specify whether project or grant) 15bo01		9b. CONTRACT NO. (if appropriate, the applicable number under which the document was written) W7714-6-09852	
10a. ORIGINATOR'S DOCUMENT NUMBER (the official document number by which the document is identified by the originating activity. This number must be unique to this document.)		10b. OTHER DOCUMENT NOS. (Any other numbers which may be assigned this document either by the originator or by the sponsor) DRDC Ottawa CR 2007-280	
11. DOCUMENT AVAILABILITY (any limitations on further dissemination of the document, other than those imposed by security classification) <input checked="" type="checkbox"/> Unlimited distribution <input type="checkbox"/> Distribution limited to defence departments and defence contractors; further distribution only as approved <input type="checkbox"/> Distribution limited to defence departments and Canadian defence contractors; further distribution only as approved <input type="checkbox"/> Distribution limited to government departments and agencies; further distribution only as approved <input type="checkbox"/> Distribution limited to defence departments; further distribution only as approved <input type="checkbox"/> Other (please specify):			
12. DOCUMENT ANNOUNCEMENT (any limitation to the bibliographic announcement of this document. This will normally correspond to the Document Availability (11). However, where further distribution (beyond the audience specified in 11) is possible, a wider announcement audience may be selected.) Unlimited			

UNCLASSIFIED

SECURITY CLASSIFICATION OF FORM

DCD03 2/06/87

13. ABSTRACT (a brief and factual summary of the document. It may also appear elsewhere in the body of the document itself. It is highly desirable that the abstract of classified documents be unclassified. Each paragraph of the abstract shall begin with an indication of the security classification of the information in the paragraph (unless the document itself is unclassified) represented as (S), (C), or (U). It is not necessary to include here abstracts in both official languages unless the text is bilingual).

As a first step in determining the way ahead for research and development of network visualisation techniques, a product and literature search of network visualisation technologies was conducted. The contractors developed a taxonomy of network visualisation product attributes and entered products into a MySQL database accessed through a web interface using PHP scripts. A report containing a table for each of the 139 products was delivered in HTML format; each table includes the attributes that could be determined from the product's Internet presence or from sales staff, and screen captures where available. This document contains a re-formatted version of this full report, fitted to letter size paper and with unfilled rows removed from the tables to minimize the document length. The citation information for the 27 documents discovered in the literature search are listed at the end, along with the abstract of each.

14. KEYWORDS, DESCRIPTORS or IDENTIFIERS (technically meaningful terms or short phrases that characterize a document and could be helpful in cataloguing the document. They should be selected so that no security classification is required. Identifiers such as equipment model designation, trade name, military project code name, geographic location may also be included. If possible keywords should be selected from a published thesaurus. e.g. Thesaurus of Engineering and Scientific Terms (TEST) and that thesaurus-identified. If it is not possible to select indexing terms which are Unclassified, the classification of each should be indicated as with the title.)

visualisation, network, network visualisation, product survey

Defence R&D Canada

Canada's leader in Defence
and National Security
Science and Technology

R & D pour la défense Canada

Chef de file au Canada en matière
de science et de technologie pour
la défense et la sécurité nationale



www.drdc-rddc.gc.ca