

Simulation of Routing Protocol with CoS/QoS Enhancements in Heterogeneous Communication Network

M. Sc. Eng. Emil Kubera
M. Sc. Eng. Joanna Sliwa
M. Sc. Eng. Krzysztof Zubel
Eng. Adrian Mroczko
Military Communication Institute
05-130 Zegrze
Poland

{e.kubera, j.sliwa, k.zubel, a.mroczko}@wil.waw.pl

ABSTRACT

The article describes the subject of QoS routing mechanism in tactical heterogeneous communication network consisting of network elements built in different technologies and connected following rules developed in the TACOMS Post 2000 project (TP2K). TP2K was an international project, the objective of which was to develop new standards of interoperability of communication networks and, apart of the interfaces, described some additional issues that are important in providing information transfer between technologically different domains. Routing in heterogeneous networks is one of the main standardization problems, especially in terms of connection oriented (CO) services. Routing mechanism should select the path to the destination, which includes only elements (subsystems) able to provide requested level of the quality of service (QoS).

The first part of the article presents proposition of new standard related to CO routing in heterogeneous communication network, which is equipped with QoS enhancements but bases on standardized routing protocol. There has been also described the conception of validation of proposed solution using OPNET simulation tool as well as simulation model used to validate operation of mentioned routing protocol.

Analysis of results obtained during performed simulation experiments is the main part of the article. Special attention was paid to the number of non user information transferred by the modeled routing protocol as well as network convergence time measured in various situations. The basis for drawing conclusions was the analysis comparing results achieved during test of standard routing protocol with tests of routing protocol with QoS enhancements.

The article is summarized by conclusions from performed researches.

1.0 INTRODUCTION

In the TACOMS Post 2000 (TP2K) project three kinds of routing mechanisms have been described:

- national (intradomain) routing;
- TP2K (interdomain) routing;
- routing to “non-TP2K” networks.

Report Documentation Page

Form Approved
OMB No. 0704-0188

Public reporting burden for the collection of information is estimated to average 1 hour per response, including the time for reviewing instructions, searching existing data sources, gathering and maintaining the data needed, and completing and reviewing the collection of information. Send comments regarding this burden estimate or any other aspect of this collection of information, including suggestions for reducing this burden, to Washington Headquarters Services, Directorate for Information Operations and Reports, 1215 Jefferson Davis Highway, Suite 1204, Arlington VA 22202-4302. Respondents should be aware that notwithstanding any other provision of law, no person shall be subject to a penalty for failing to comply with a collection of information if it does not display a currently valid OMB control number.

1. REPORT DATE 01 OCT 2006		2. REPORT TYPE N/A		3. DATES COVERED -	
4. TITLE AND SUBTITLE Simulation of Routing Protocol with CoS/QoS Enhancements in Heterogeneous Communication Network				5a. CONTRACT NUMBER	
				5b. GRANT NUMBER	
				5c. PROGRAM ELEMENT NUMBER	
6. AUTHOR(S)				5d. PROJECT NUMBER	
				5e. TASK NUMBER	
				5f. WORK UNIT NUMBER	
7. PERFORMING ORGANIZATION NAME(S) AND ADDRESS(ES) Military Communication Institute 05-130 Zegrze Poland				8. PERFORMING ORGANIZATION REPORT NUMBER	
9. SPONSORING/MONITORING AGENCY NAME(S) AND ADDRESS(ES)				10. SPONSOR/MONITOR'S ACRONYM(S)	
				11. SPONSOR/MONITOR'S REPORT NUMBER(S)	
12. DISTRIBUTION/AVAILABILITY STATEMENT Approved for public release, distribution unlimited					
13. SUPPLEMENTARY NOTES See also ADM202422., The original document contains color images.					
14. ABSTRACT					
15. SUBJECT TERMS					
16. SECURITY CLASSIFICATION OF:			17. LIMITATION OF ABSTRACT UU	18. NUMBER OF PAGES 35	19a. NAME OF RESPONSIBLE PERSON
a. REPORT unclassified	b. ABSTRACT unclassified	c. THIS PAGE unclassified			

Simulation of Routing Protocol with CoS/QoS Enhancements in Heterogeneous Communication Network

National routing mechanisms depend on technology used and are outside the scope of TP2K standardisation. Routing to “non-TP2K” networks may use both intra and interdomain routing mechanisms depending on gateway location. Validation of this mechanism was carried out in one of TP2K work packages and described in another article [4]. The main subject of this paper is the interdomain TP2K routing, which has been standardised in this project. It will be implemented in Interoperability Points (IOPs) - interfaces, which are to provide seamless interworking between national elements realized in different technologies.

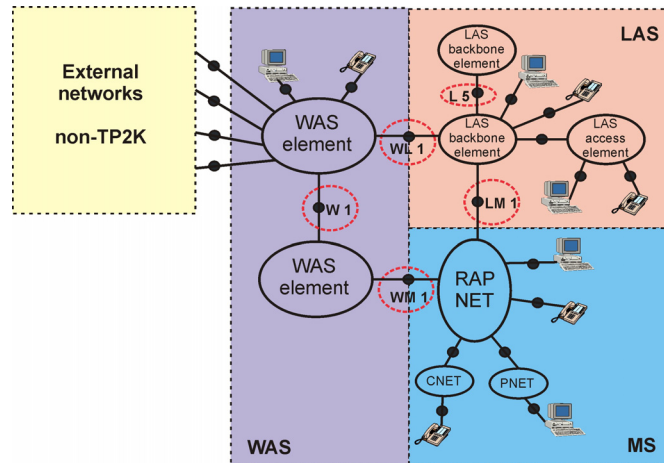

Figure 1. General architecture of TP2K system.

General structure of TP2K topology was presented in figure 1. It depicts basic standardised subsystems and interfaces. IOPs using TP2K interdomain dynamic routing were coloured in red. Other IOPs in the TP2K system will use static routing.

After analyses performed in the TP2K project, standard interdomain routing protocol BGP-4 was chosen as a base for developing routing mechanism for connection oriented services in the TP2K system. This standard protocol had to be extended to fulfil TP2K requirements.

2.0 BGP PROTOCOL

BGP is a path-vector protocol. Routing information that it distributes contains a sequence of ASs (Autonomic Systems) numbers carried by the corresponding routing updates. BGP chooses the best route based on the number of ASs – with the preference of the shortest one. There are four types of BGP messages: OPEN, UPDATE, NOTIFICATION and KEEPALIVE. The routing reachability information is advertised in UPDATE messages. Through the UPDATE messages, BGP routers may announce or withdraw routes. A route advertisement consists of a set of path attributes. The most important is Network Layer Reachability Information (NLRI) – a list of IP address prefixes.

Unfortunately current BGP-4 standard does not meet TACOMS requirements. It limits the route decision process to be based on number of hops through ASs and does not support QoS information. Several drafts describe the QoS extensions for BGP, but none of them fully meets TP2K requirements.

In one of the TP2K work packages (WP13411) there has been described the solution that should be acceptable for TP2K application. Proposed solution is based on using information about the class of service (CoS) supported and quality of service (QoS) offered by NEs. The main objective of the CoS/QoS enhancements to routing is to ensure that the selected path is able to support specific calls. For example, if subscriber requests a video call, routing with proposed extensions should not select the shortest path but a

set of routes (through particular network elements) that have capability to transport video stream. Additionally, if more than one route meets CoS requirements, the route that offers better QoS parameters (e.g. lower delay) should be chosen.

To provide CoS/QoS routing, the BGP UPDATE message must be changed to allow distribution of CoS and QoS information. The NLRI format should be enhanced to support CoS/QoS advertisements. Class of services attributes specified in TP2K are: voice, data and video. QoS parameters included as an extension to standard BGP should be represented by delay introduced by particular NEs.

BGP-4 routing protocol with proposed extensions has not been implemented in OPNET MODELER yet. That is why this solution had to be created in this environment from scratch, based on standard BGP-4 implementation.

3.0 CONCEPTION OF VALIDATION

OPNET MODELER was chosen as the simulation tool for validation of the routing protocol. It enables testing different telecommunication areas, including routing protocols. OPNET simulating package is one of the products of OPNET Technologies Inc. Programming environment of the package (C, C++) enables modelling the network in a great detail. BGP-4 routing protocol was implemented in OPNET simulation tool as a standard model. This detailed implementation provides possibility to configure many BGP attributes.

Validation of proposed mechanism should check if interdomain routing protocol can find a suitable path to the destination. The second objective of this validation is measuring the convergence time and the number of routing information generated by BGP devices. Comparison of results collected in experiments related to standard BGP-4 and BGP with proposed extensions is crucial. Summing up: validation of proposed routing protocol should give answers to the following questions:

- Does the route selected by the routing protocol meet requirements?
- What is the convergence time of the network?
- How much routing information do the BGP devices generate?
- What is the influence of failures and mobility on the correctness of routing?
- Do the proposed CoS/QoS extensions meet system requirements?

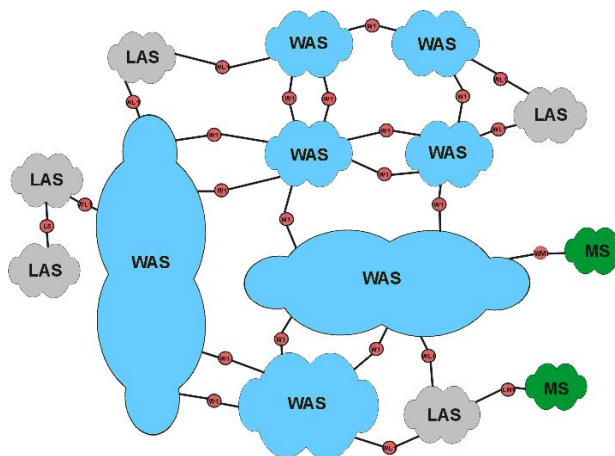

Figure 2. The main topology for routing tests.

Simulation of Routing Protocol with CoS/QoS Enhancements in Heterogeneous Communication Network

To validate interdomain TP2K routing protocol there have been proposed three topologies representing networks with different degree of complication. The largest one was presented in figure 2. Tests with several topologies were necessary to check if the routing protocol operates correctly in different network configurations and conditions.

Based on the topology presented in figure 2, there were modelled additional topologies to check the behaviour of the routing protocol in special situations, such as: the failure of links, failure of network element, addition of new network element, dislocation of the network element and dislocation of the subscriber. These experiments enabled measuring convergence times of the network in these special situations as well as the amount of the non-user traffic generated by the routing protocol under these circumstances. Additional topologies with subscribers were designed to investigate whether the mechanism of the internal routing protocol is able to find suitable route to the destination in the TACOMS system.

Based on routing requirements, the simplified model of network has been proposed. The model was created with the following assumptions:

- particular NEs are represented by the IP cloud. Their interfaces correspond to IOPs and UTAPs;
- IOPs interfaces have BGP routing protocol implemented, UTAPs interfaces use OSPF routing protocol;
- links are non-blocked, with high throughput.

The model of the communication network was built using models available in the OPNET model library: *ethernet4_slip8_cloud*, *10BaseT* and *PPP_SONET_OC12* lines, *ethernet_wkstn*.

OPNET can capture several statistics, which enable validation of BGP protocol operation. All statistics were captured in the “bucket mode”. The main output characteristic captured during the simulation was *Global Statistic* – BGP Traffic Received (bps) and BGP Traffic Sent (bps). The easiest way to check if the route selected by the routing protocol meets requirements is to present it graphically on the network model. OPNET provides such possibility and enables to trigger the animation application that shows the route through which data packets are sent.

Since the BGP-4 standard does not fulfil TACOMS requirements, addition of special extensions in the OPNET BGP model was necessary. The implementation of CoS/QoS extensions in BGP protocol was performed in the OPNET environment based on the WP13411 guidelines. Implementation of CoS/QoS enhancements imposes some simplifications. The most important one was related to modelling of CoS operation. Particular NEs could only be manually set to operate in the two states: “CoS supported” (e.g. voice supported) or “CoS not supported” (e.g. voice not supported). Setting “CoS not supported” in the NE, caused elimination of this NE from the process of the routes selection.

In order to provide CoS/QoS routing, the BGP UPDATE message had to be changed. The NLRI format was enhanced to advertise the CoS/QoS parameters. Implementation of CoS/QoS extensions in OPNET was related to modification of a few standard BGP processes: *bgp_process*, *bgp_conn_process*, *bgp_support_external_source*.

The last process mentioned above is the most important, responsible for selecting suitable paths based on CoS/QoS attributes. It holds in fact the algorithm of routing operation. Enhanced BGP protocol algorithm implemented in OPNET was shown in figure 3.

Simulation of Routing Protocol with CoS/QoS Enhancements in Heterogeneous Communication Network

$A = \{\text{routes to destination}\}$
 $B_i = \{\text{CoS for route } a_i\}$
 $C = \{\text{delay for every route}\}$
 $D = \{\text{number of hops for every route}\}$
 $E = \{\text{routes with required CoS}\}$
 $F = \{\text{minimum delays}\}$
 $G = \{\text{minimum numbers of hops}\}$
 $S = \{\text{selected route (s)}\}$
 $x - \text{required CoS}$
 $a_i \in A$
 a_i is the route to the destination
 Every a_i is characterized by: the set of CoS (B_i), delay (c_i) and number of hops (d_i)

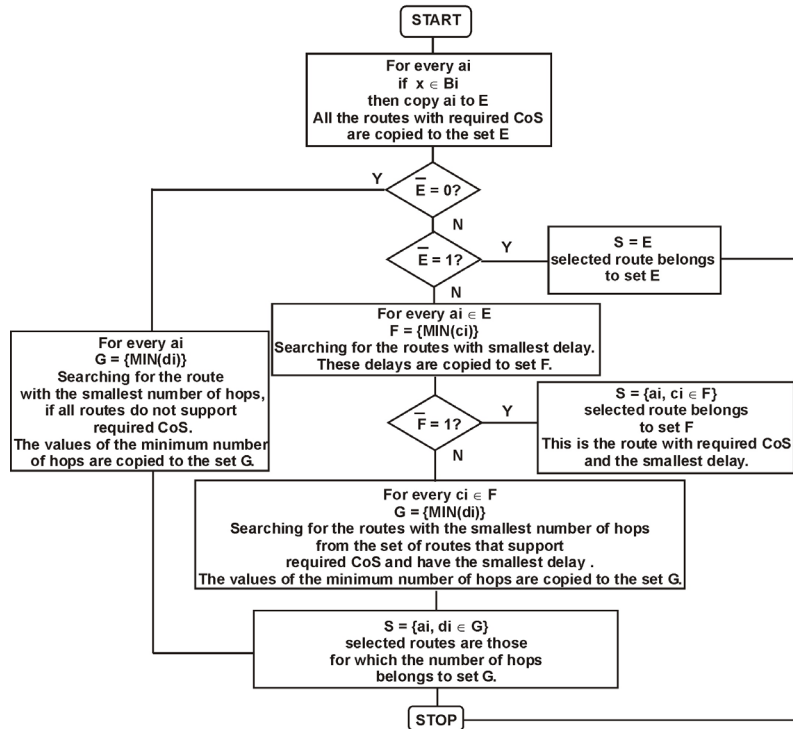

Figure 3. BGP CoS/QoS routing algorithm.

The decision process starts when the router finds all the routes to the destination. These are routes a_i , that belong to set A . From within the entries of this set, there must be found routes that support required CoS (x). These routes are copied to the set E . If there are no routes that support required CoS, the routes will be chosen based on the number of hops (like in standard BGP). There will be checked the number of hops for every route a_i and chosen the route with the smallest value of this parameter. If there is one route that support required CoS, this one will be chosen as the best one and the algorithm stops. If there is more than one route to the destination that supports required CoS (these routes belong to the set E), the algorithm will search for the routes with the smallest delay from within the set E (for every $a_i \in E$, $F = \{\text{MIN}(c_i)\}$). The minimum values of delay (c_i) will be placed in the set F . If the set F has only one element, the route a_i corresponding to the delay c_i will be selected as the best one. When the set F has more than one element, the algorithm will make a decision as the standard BGP protocol, based on the number of hops. The algorithm takes the routes whose delay belongs to the set F ($c_i \in F$), and checks the values of the number of hops of these routes. It selects the smallest ones ($\text{MIN}(d_i)$) and places them in the set G . Then the routes a_i for which the $d_i \in G$ are selected as the best ones.

4.0 RESULTS OF THE VALIDATION

Validation of proposed routing mechanism was divided into two parts (scenarios). The first scenario was related to investigation of the standard BGP protocol, the second one - BGP with CoS/QoS extensions. Within the scope of both scenarios there were experiments involving differing network topologies as well as corresponding parameters. Comparison of results collected in both scenarios related to standard BGP-4 and BGP with proposed CoS/QoS extensions was crucial.

The experiments were devoted to test the load of the network with routing information and its convergence time. These experiments differ from each other in the degree of complication of network structure and additional modifications in the topology.

4.1 Results for the standard routing protocol BGP-4

In the main experiment, the amount of routing information and the network convergence time have been evaluated. The topology modelled in OPNET was presented in figure 4.

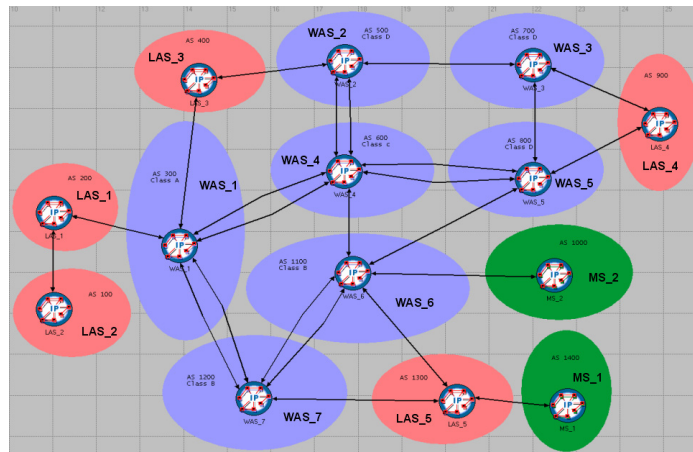

Figure 4. BGP testing topology.

Results achieved:

- The amount of routing information, Fig. 5.

Figure 5 presents total BGP traffic sent by all the BGP routers in large network. The amount of routing information received had similar values. The BGP traffic in the investigated network had the highest value (about 324 kbps) in the first phase of the simulation, when the BGP routers started to generate UPDATE messages. When NEs had exchanged all UPDATE messages, they built their own routing tables, and after that only KEEPALIVE messages were transferred between nodes. In this situation traffic in the network decreased significantly to less than 5 kbps up to the end of simulation.

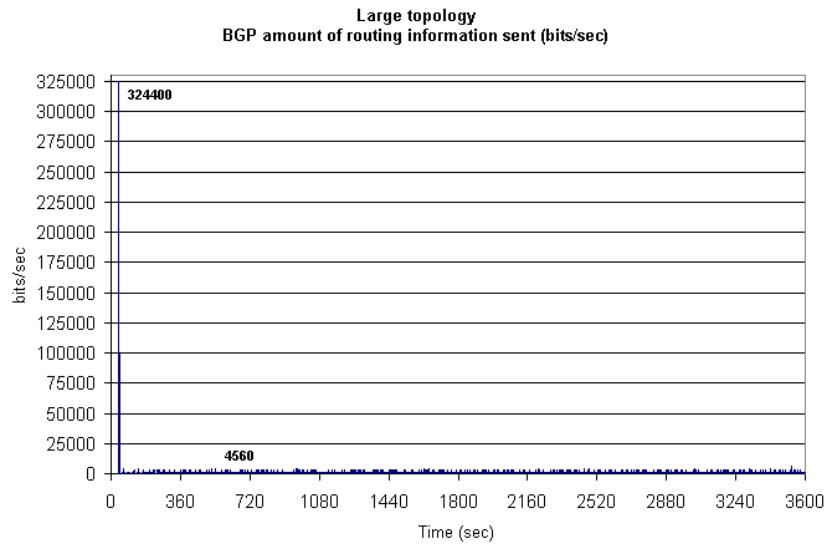

Figure 5. Amount of BGP routing information.

b. The convergence time, Fig. 6.

The convergence time (CT) was assessed based on the graph of amount of routing information sent. This is the time between the start of BGP protocol operation and the moment when BGP routers have finished the process of exchanging their routing tables (UPDATE messages). After this time the network reached stable state. Since network elements did not change their state up to the end of the simulation, no more UPDATE messages have been generated and only KEEPALIVE were transferred between nodes every 30 seconds. As figure 6 shows, the convergence time for the large network was about 6.4 seconds.

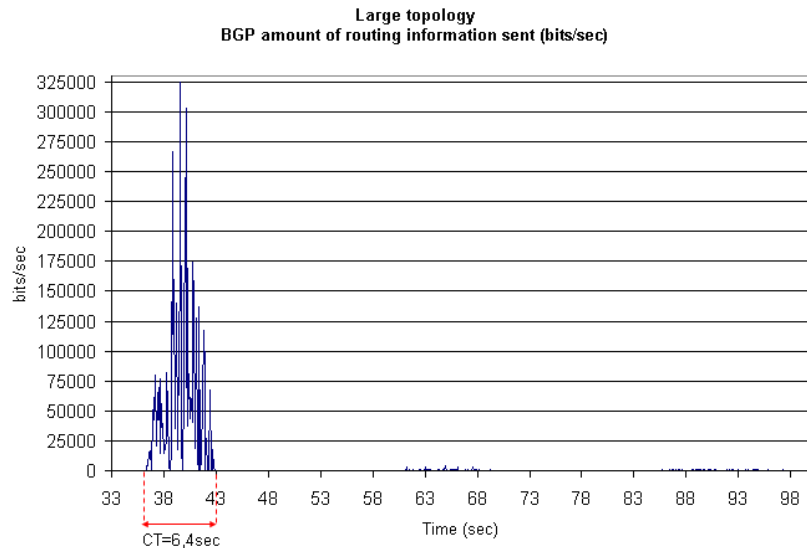

Figure 6. BGP convergence time.

Simulation of Routing Protocol with CoS/QoS Enhancements in Heterogeneous Communication Network

In the experiment related to the accuracy of route selection, the minimum hops path has been chosen according to the operation of the standard BGP-4.

Next group of experiments related to the amount of routing information and the network convergence time were carried out using topologies modelling special circumstances, such as: the failure of links, failure of network element, addition of new network element, dislocation of the network element and dislocation of the subscriber. After failures or dislocations, all nodes in the topology had to be informed and had to introduce modifications in the routing tables. All changes in the topology resulted in generating UPDATE messages and increased temporary routing information throughput. Detailed results achieved in these experiments were not included in this article, but comparison of these results with obtained for the CoS/QoS BGP routing protocol was presented at the end of this chapter.

4.2 Results for the CoS/QoS BGP routing protocol

This scenario was divided into the same groups of experiments as scenario related to the standard BGP-4 routing protocol. All topologies and other input parameters were the same as in the adequate experiments for the standard BGP-4 scenario. The only difference was using CoS/QoS extensions in the routing mechanism, as presented in the previous chapter.

The amount of routing information and the network convergence time was tested in the main experiment. The topology modelled in OPNET was presented in figure 4.

Results achieved:

- a. The amount of routing information, Fig. 7.

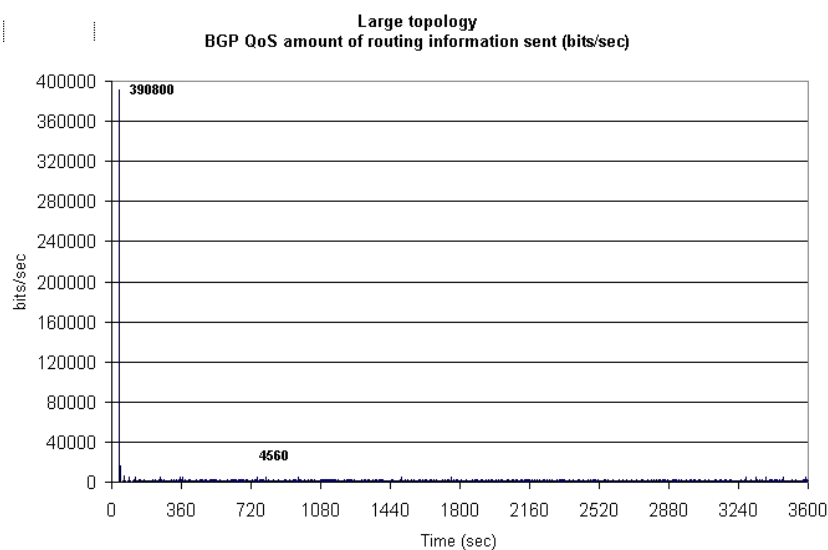

Figure 7. Amount of CoS/QoS BGP routing information.

The figure 7 presents total traffic of BGP with CoS/QoS extensions sent by all the BGP routers in the large network. The BGP traffic in the tested network has the highest value (about 390 kbps) during the time of exchanging UPDATES.

- b. The convergence time, Fig. 8.

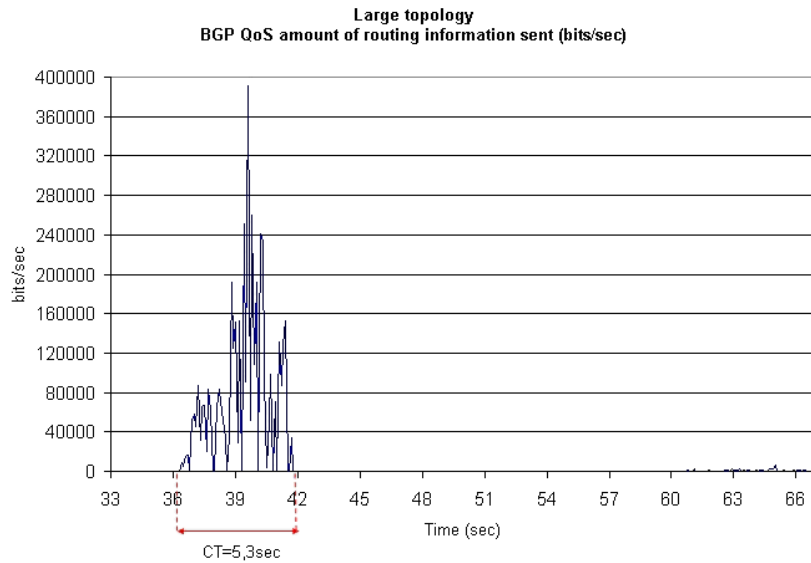

Figure 8. CoS/QoS BGP convergence time.

As figure 8 shows, convergence time for the large network was about 5.3 seconds. After this time the network reached its stable state up to the end of the simulation.

The experiment related to the accuracy of route selection, was divided into three parts:

- The first – LAS_3 and WAS_4 network elements did not support requested class of service (see Fig.4);
- The second – all NEs supported requested class of service;
- The third – all NEs supported requested class of service and two routes introduced the same minimum delay.

In the first part, since LAS_3 and WAS_4 did not support requested CoS, these elements could not be included in the routing table. All other NEs in the topology supported requested CoS. The routing mechanism has taken into consideration only the suitable NEs and selected the route with the lowest delay.

In the second part, all NEs in the topology supported requested CoS, so the routing mechanism selected the route with the lowest delay.

In the third part, all NEs in the topology supported requested CoS and the WAS_2 network element delay was increased by 5 ms to model two routes with the same minimum delay. In this specific situation the routing mechanism selected the route with the lowest number of hops.

Results presented above confirmed, that the routing mechanism with proposed extensions can find suitable path to the destination – it selects only NEs that can fulfil call requirements.

The last group of experiments related to the amount of routing information and the network convergence time were carried out based on topologies with special circumstances, as described in the scenario with standard BGP-4 routing protocol. Comparison of these results with obtained in the standard BGP-4 routing protocol, were presented below.

Simulation of Routing Protocol with CoS/QoS Enhancements in Heterogeneous Communication Network

4.3 Comparison of results

The main objective of this part of the article is to compare results achieved in both scenarios – for standard BGP routing and for BGP routing with CoS/QoS extensions. Presented comparison was divided into a few groups according to types of performed experiments.

At first there was compared the amount of routing information and the convergence time achieved for experiments with standard BGP and for BGP with CoS/QoS extensions, for three sizes of topology.

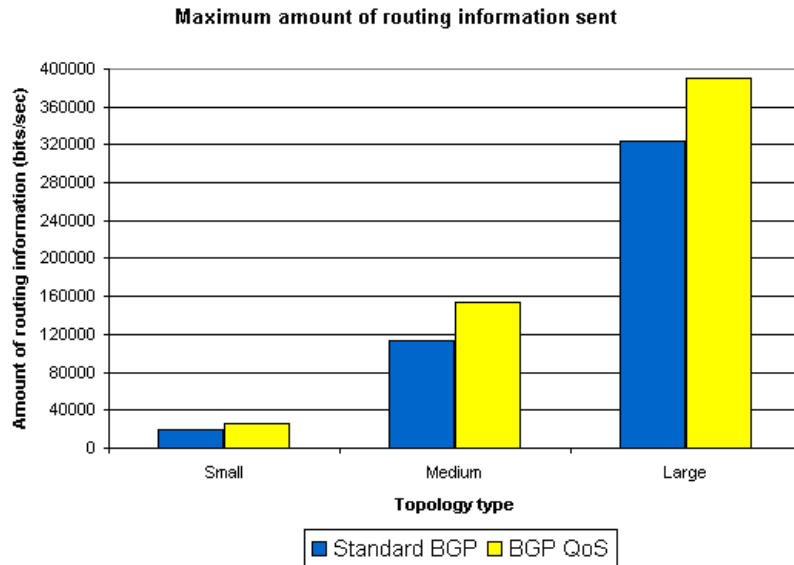

Figure 9. Routing information amount comparison.

Since extensions introduced to BGP protocol increased the size of UPDATE message, the amount of routing information in the group of experiments for BGP with CoS/QoS was greater than achieved in the standard BGP scenario – for all tested topologies, Fig. 9.

In tests performed for standard BGP, convergence time was very low in the small topology and a few times greater for medium and large topology (for both on the similar level), Fig. 10. In tests performed for BGP with CoS/QoS extensions, convergence time in the small topology was the same as achieved for standard BGP tests. The greatest convergence time was measured in the medium topology – 4.5 seconds more than for large topology. The CoS/QoS extensions introduced in the BGP should not significantly increase the network convergence time. This value will be dependent on the network configuration and parameters of elements used in the topology.

Simulation of Routing Protocol with CoS/QoS Enhancements in Heterogeneous Communication Network

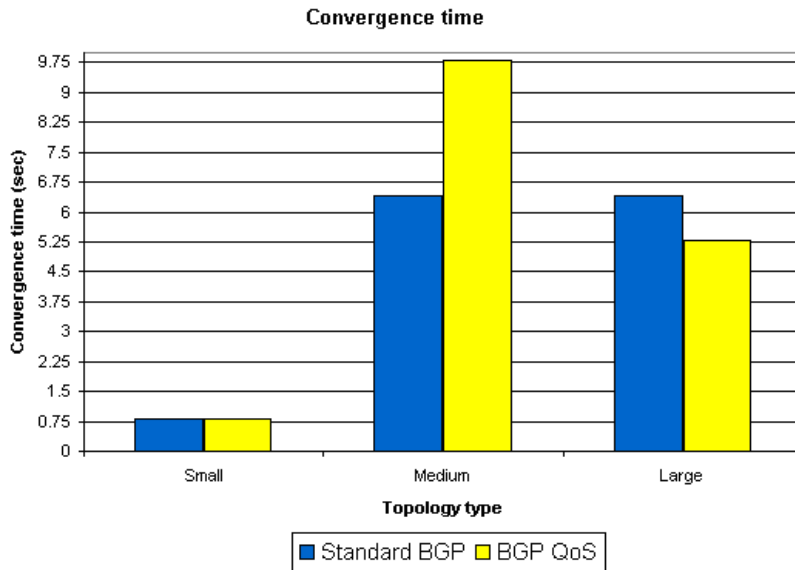

Figure 10. Network convergence time comparison.

There were compared the amount of routing information and the convergence time achieved for experiments with standard and enhanced BGP in some special situations, such as: failure of links, failure of network element and addition of the new network element. Graphs show values collected after changes (failures or addition) during the simulation. In this group of experiments only large topology was examined. In tests related to the BGP protocol with CoS/QoS it was assumed that all NEs support the required CoS.

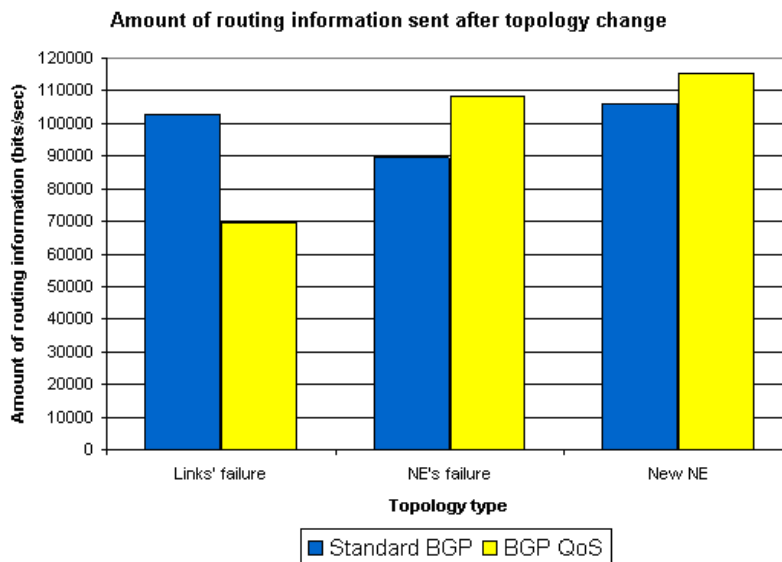

Figure 11. Routing information amount comparison.

Simulation of Routing Protocol with CoS/QoS Enhancements in Heterogeneous Communication Network

After all specified changes in the topology, similar amount of routing information was transferred, Fig. 11. In many cases it was near 100 kbps. It is about three times less than after the simulation started. It means that after changes in the topology, only necessary (not all) routing information was exchanged. After NE failure and addition of new NE, the amount of routing information was greater for CoS/QoS scenario than for the standard BGP scenario. After links failure the opposite situation appeared.

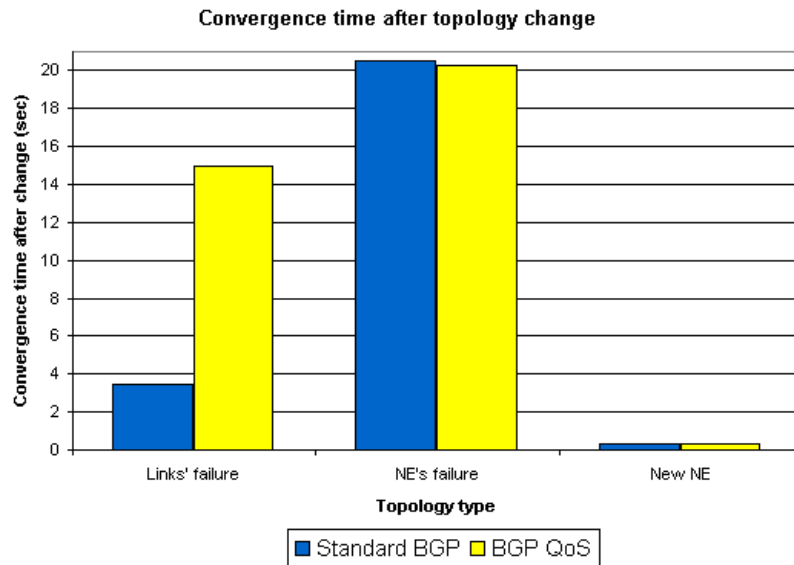

Figure 12. Network convergence time comparison.

The greatest convergence time was measured for NE failure experiments – similar for both standard and enhanced BGP protocol, Fig 12. After links failure, convergence time in the enhanced BGP scenario was a few times longer than in the standard BGP tests. The shortest convergence time was obtained in experiments related to addition of new NE – the same values for standard and enhanced BGP scenarios.

Performed simulation experiments made possible evaluation of the proposed routing mechanism operation in different network configurations.

5.0 SUMMARY

The validation was carried out using OPNET simulation tool which enables detailed investigation of routing behaviour.

Researches related to the standard BGP-4 were performed based on standard model library provided by OPNET. Researches using BGP routing protocol with CoS/QoS extensions were performed based on modified model that was created according to TP2K requirements. The reason for carrying out researches of standard BGP protocol was to create the point of reference for comparison with validated solution of BGP with proposed extensions.

In the process of routing mechanism validation some simplifications were assumed. The most important one was to use only IP elements.

The most important goal of presented validation was to check the specifics of selecting the route. The standard BGP protocol selected the route with the minimum number of hops which can consist of elements that do not meet call requirements. The validation of proposed solution shows that BGP with CoS/QoS extensions can find suitable path to the destination – the path consisting of only elements which fulfil the call requirements. Elimination of the elements that do not meet CoS requirements usually introduced greater number of NEs on the selected path than it was for the standard BGP.

The second important result of the validation was measuring the network convergence time and number of routing information generated by BGP devices in different topologies and situations. In this case comparison of the results achieved for standard and enhanced BGP routing protocol was crucial. The amount of routing information generated by enhanced BGP was usually slightly greater than for standard BGP protocol. It was obvious because of increased size of UPDATE message. Convergence time depended on the topologies' sizes, NEs' parameters and situations modelled. In some experiments the convergence time was greater for enhanced BGP than for standard BGP, in others vice versa. The lowest convergence time was achieved for experiments related to addition of a new NE when only some necessary UPDATE information were exchanged.

Proposed CoS/QoS extensions should increase the call completion probability – selected route always fulfils call requirements.

BIBLIOGRAPHY

- [1] TACONE. WP 13411 CO Routing
- [2] TACONE. WP 13419 CO Routing – enhancements and validation
- [3] OPNET Technologies. OPNET documentation
- [4] Application of X.500 standard to support routing in mobile heterogeneous communications systems, Databases: Applications and systems Conference, Ustron 2005, Poland

**Simulation of Routing Protocol with CoS/QoS
Enhancements in Heterogeneous Communication Network**





Simulation of routing protocol with CoS/QoS enhancements in heterogeneous communication network

Emil Kubera
Joanna Śliwa
Krzysztof Zubel
Adrian Mroczko

Military Communication Institute



AGENDA

- **Background information**
 - Routing protocols in TACOMS Post 2000 project
 - BGP and CoS/QoS BGP
- **Conception of validation**
 - Network topologies
 - Simulation object
 - CoS/QoS enhancements' implementation
 - Routing algorithm
- **Simulation results**
 - Results for the standard BGP
 - Results for BGP with CoS/QoS enhancements
 - Comparison of results
- **Summary**



Routing in TACOMS Post 2000 project (TP2K)

- **Intradomain routing (national)**
- **Routing to „non-TP2K” networks**
 - Uses inter- and intradomain routing
 - Based on the *best gateway selection* mechanism
- **TP2K interdomain routing**
 - Defined in interoperability points (IOPs)
 - Standardized in TP2K
 - Implemented in edge devices of W1 family IOPs

Routing in TP2K

External network (non-TACOMS) interfaces	
name	type
Ex11	ATM
Ex12	Ethernet
Ex13	ISDN PRI
Ex15	STANAG 4578
Ex17	STANAG4206
Ex17	X.75/X.25
Ex18	Analogue

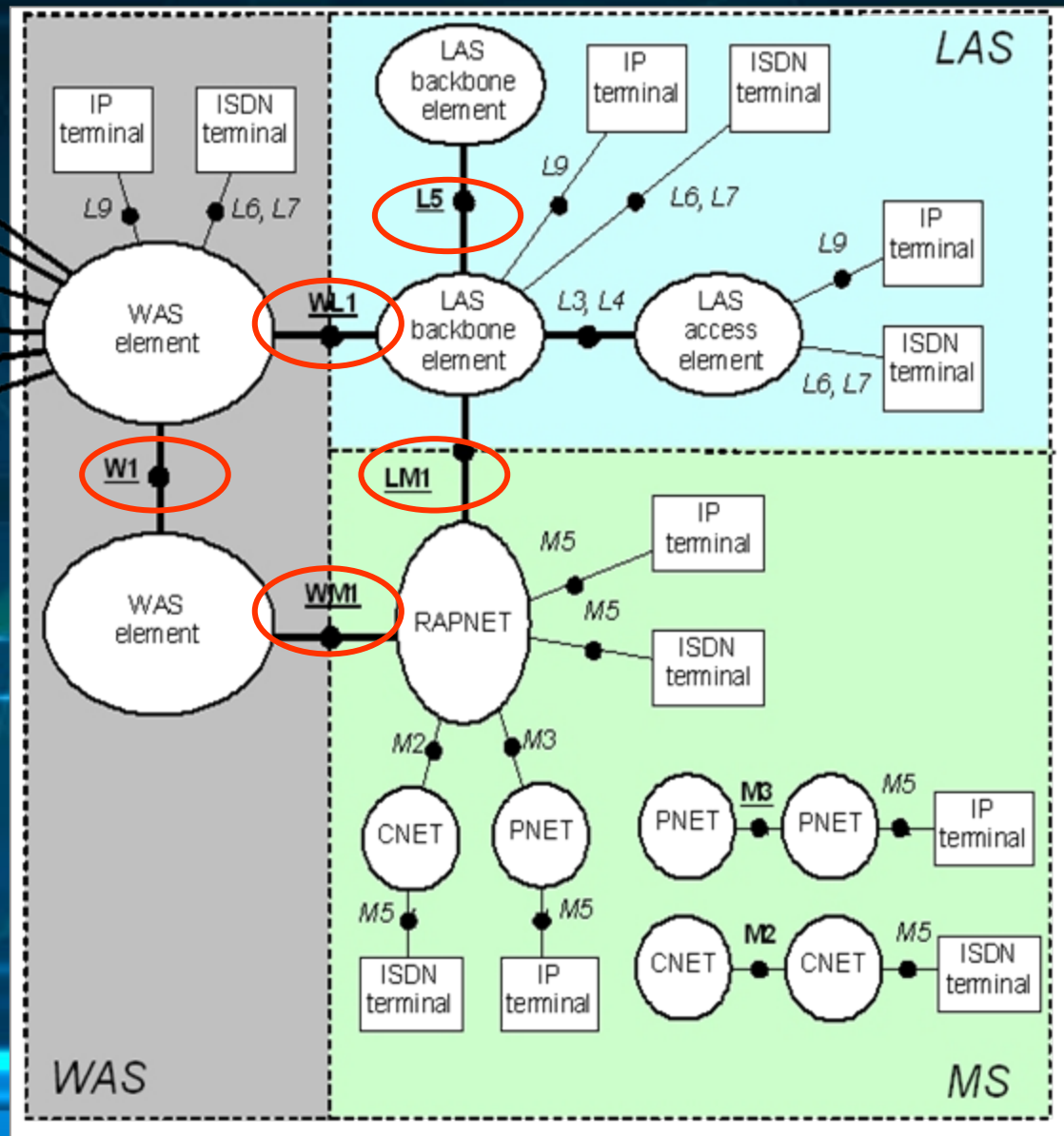

Border Gateway Protocol (BGP)

- Interdomain routing protocol defined in RFC 1771
- Uses Path Vector algorithm
- Divides network into separate autonomous systems (ASs)
- Distributes routing information containing a sequence of ASs (on demand updates)
- Chooses the best route based on one criterion – the number of ASs – the shortest route is preferred
- Uses TCP as the transport protocol
- Drawbacks of standard BGP:
 - limits the route decision process to be based on the number of hops through ASs
 - does not support QoS information

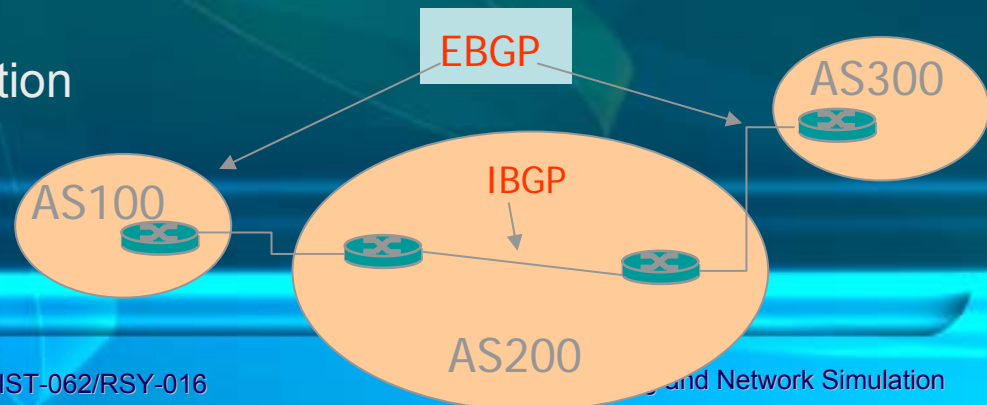



BGP with CoS/QoS extensions

- Defined as an **interdomain routing protocol** in TP2K project
- Based on using information about the **class of service (CoS)** supported and **quality of service (QoS)** offered by NEs
- Main objective of the **CoS/QoS enhancements** to routing is to ensure that the selected path is able to support specific calls
- Standard BGP modifications:
 - Extension of the NLRI attribute in UPDATE message
 - CoS - information about the class of service supported by NE
 - Voice
 - Data
 - Video
 - QoS – information about the quality of service offered by NE
 - Delay
- CoS/QoS enhancements to routing are to ensure that the selected path leads through network elements that offer required class of service and the lowest delay



Conception of validation

- Simulation tool: OPNET Modeler
- Validation method: comparison of results for standard BGP and BGP with CoS/QoS extensions
- Aim:
 - To check if interdomain routing protocol can find a suitable path to the destination
 - To measure the convergence time and the number of routing information generated by BGP devices

Network topologies

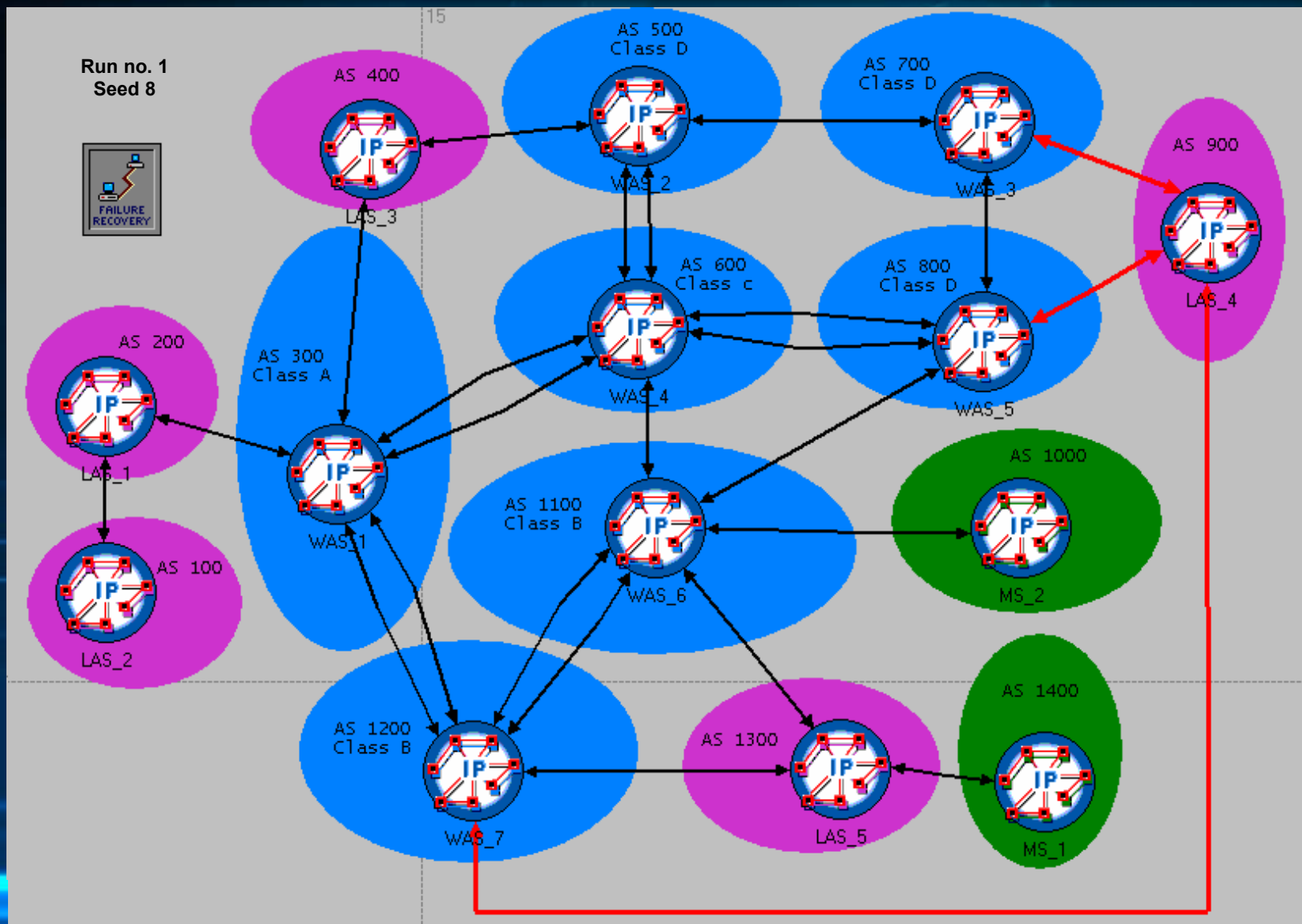

OPNET model

- Model elements

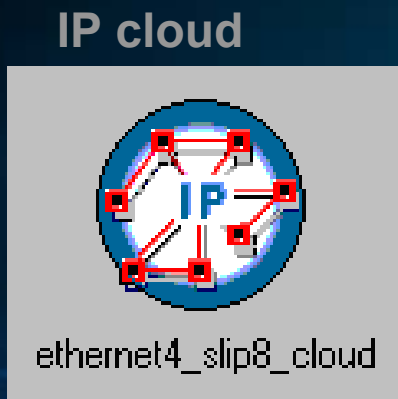

(LAS_5) Attributes

Attribute	Value
name	LAS_5
model	ethernet4_slip8_cloud
BGP Parameters	[...]
CPU Background Utilization	None
CPU Resource Parameters	Single Processor
EIGRP Parameters	[...]
IGRP Parameters	[...]
IP Background Traffic Characteristics	[...]
IP Multicast Parameters	Default
IP Processing Information	[...]
IP Routing Parameters	[...]
IS-IS Parameters	[...]
MPLS Parameters	[...]
OSPF Parameters	[...]
Packet Discard Ratio	0.5%
Packet Latency (secs)	constant (0.1)
RIP Parameters	[...]
bgp.Sup CoS	2
bgp.delay	100
bgp.wsk.aznik	promoted

Apply Changes to Selected Objects Advanced

Details Promote Cancel OK





OPNET model – CoS/QoS extensions

- UPDATE message modification (NLRI field) – according to TP2K
- Possible NE's states while operating with CoS/QoS BGP:
 - CoS supported
 - CoS not supported → NE excluded from the set of NEs able to route the call
- QoS supported: delay
- Standard OPNET BGP processes' modifications:
 - `bgp process` (INIT state and FB functional block)
 - `bgp_conn process` (FB)
 - `bgp_support` (external file – the algorithm of protocol's operation)



BGP CoS/QoS - routing algorithm

$A = \{\text{routes to destination}\}$
 $B_i = \{\text{CoS for route } a_i\}$
 $C = \{\text{delay for every route}\}$
 $D = \{\text{number of hops for every route}\}$
 $E = \{\text{routes with required CoS}\}$
 $F = \{\text{minimum delays}\}$
 $G = \{\text{minimum numbers of hops}\}$
 $S = \{\text{selected route (s)}\}$
 x - required CoS
 $a_i \in A$
 a_i is the route to the destination
 Every a_i is characterized by: the set of CoS (B_i), delay (c_i) and number of hops (d_i)

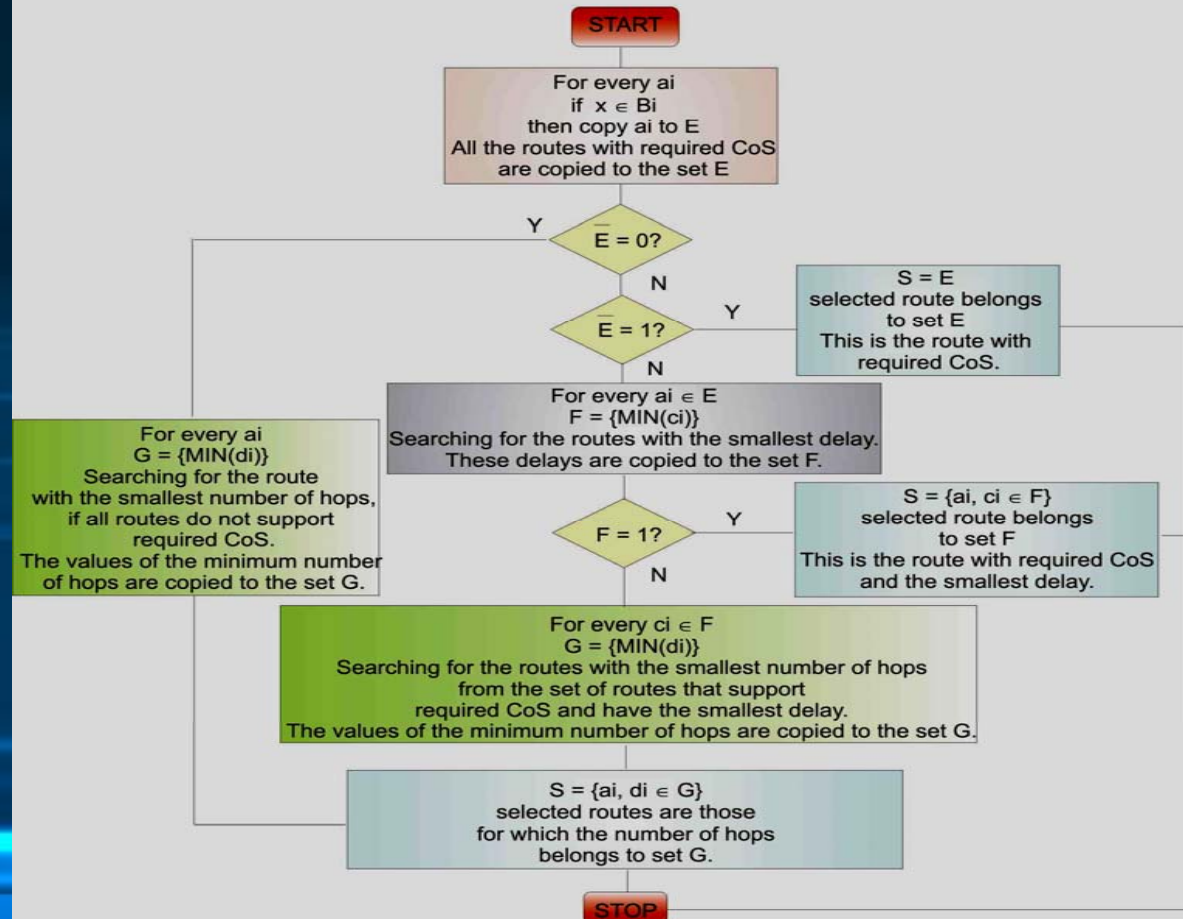



SIMULATION RESULTS - BGPv4

Total amount of BGP routing information sent (bps)

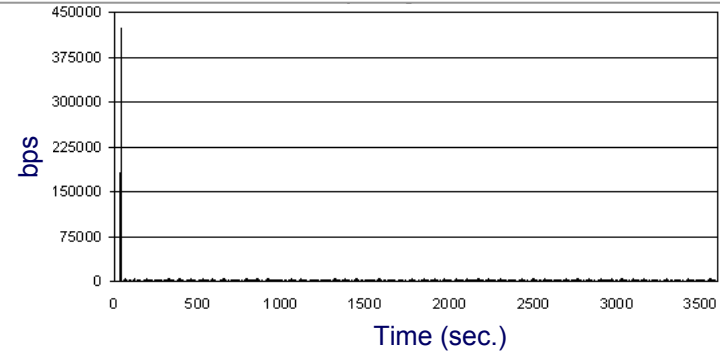

Network convergence time [seconds]

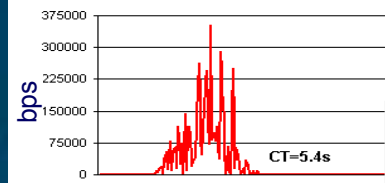
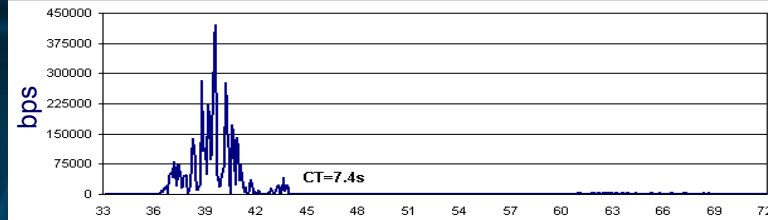

Network convergence time after NE's reconnection to the network [seconds]

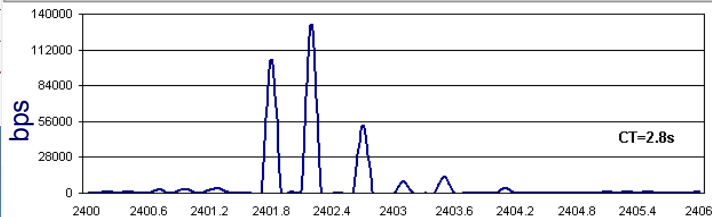

Total amount of BGP routing information sent after NE's dislocation (bps)

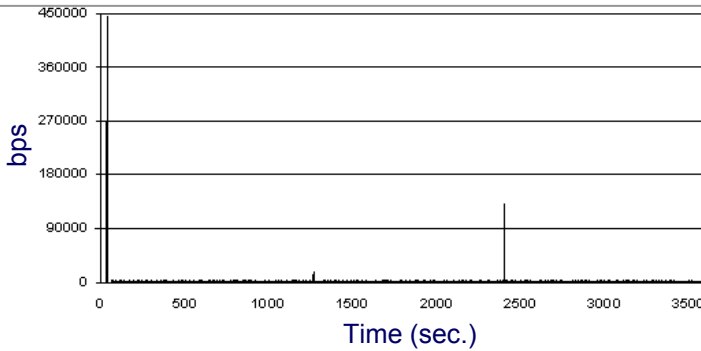

Network convergence time after NE's disconnection from the network [seconds]

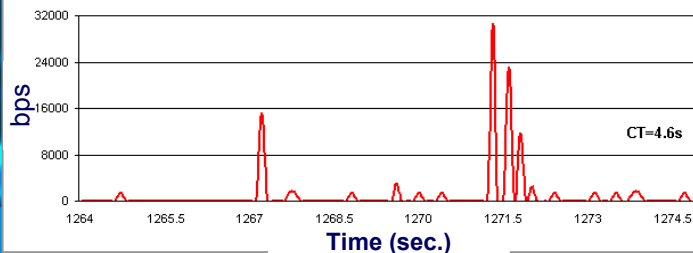
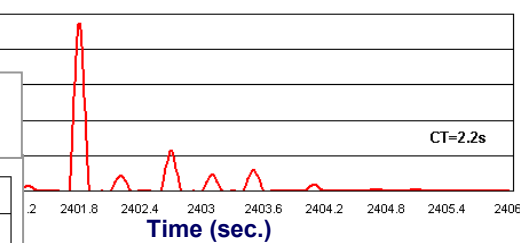
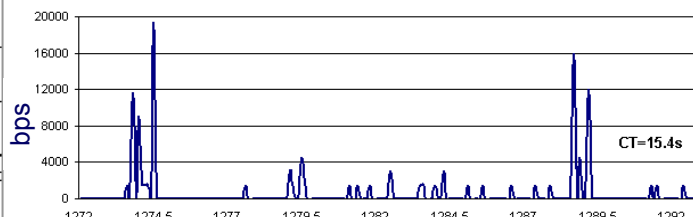



SIMULATION RESULTS - BGPv4

- Selected route

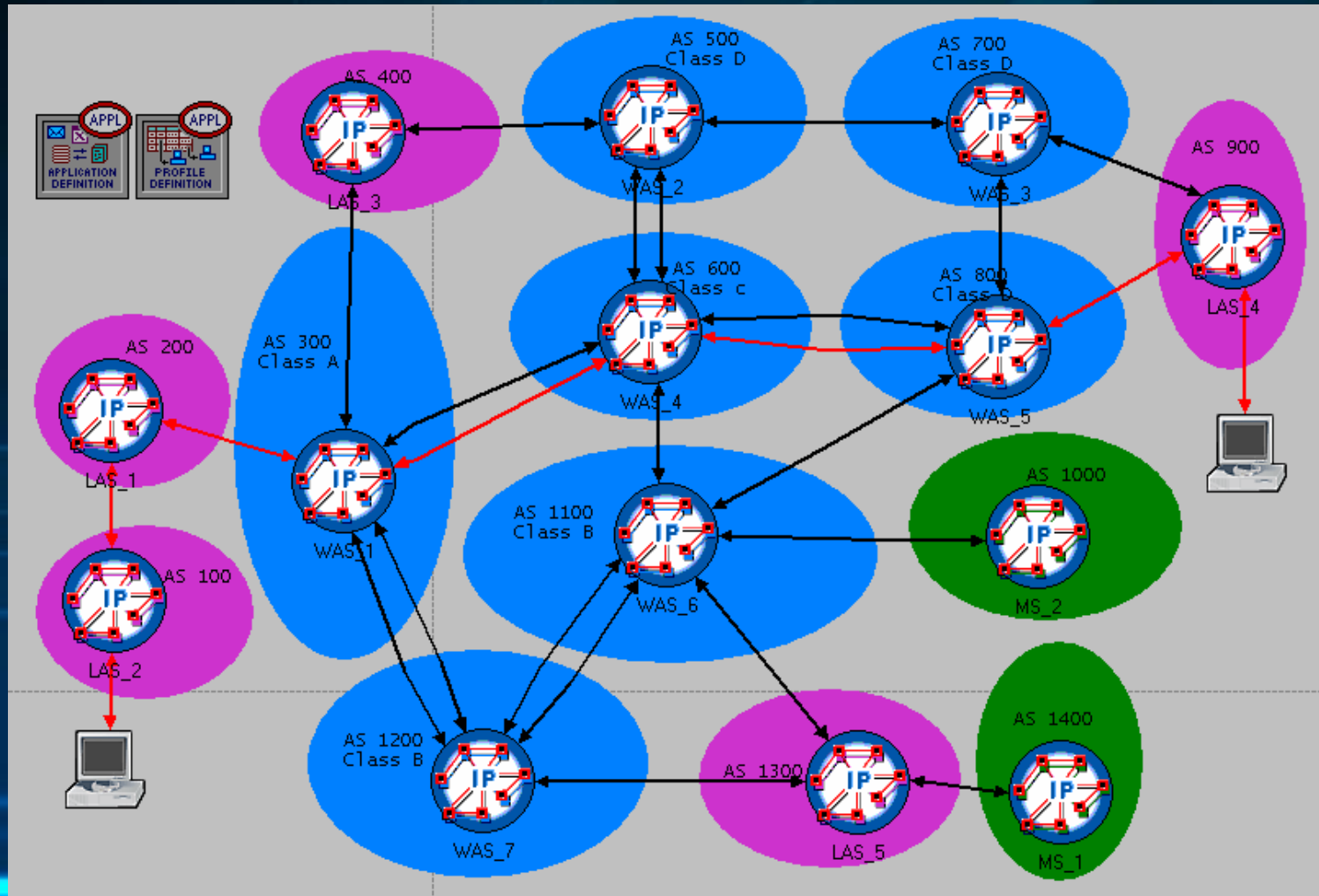



SIMULATION RESULTS - CoS/QoS BGP

Total amount of CoS/QoS BGP routing information sent (bps)

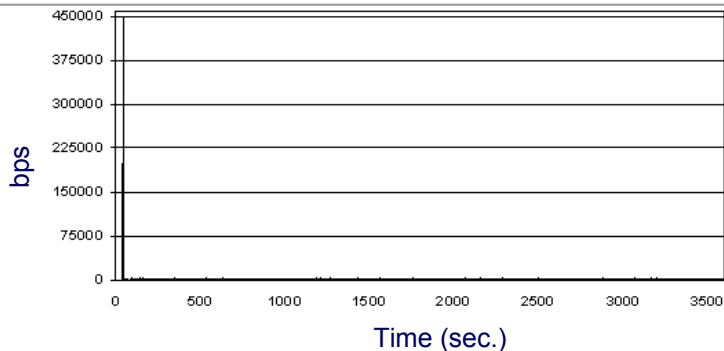

Network convergence time [seconds]

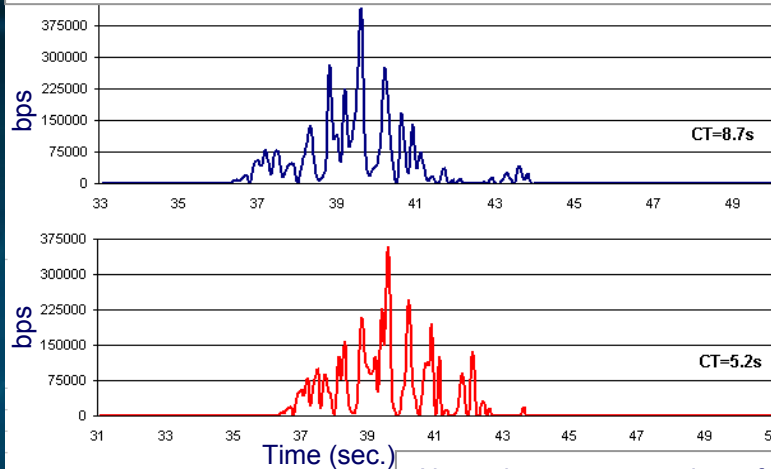

Total amount of CoS/QoS BGP routing information sent after NE's dislocation (bps)

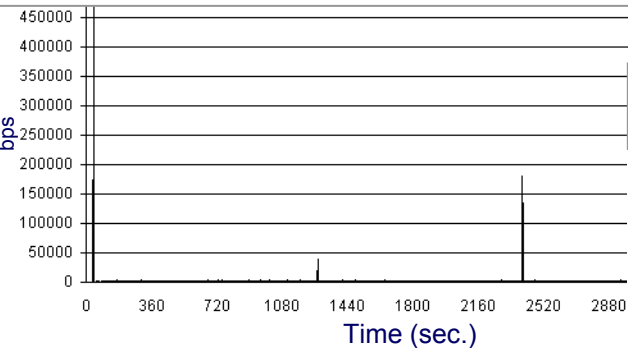

Network convergence time after NE's reconnection to the network [seconds]

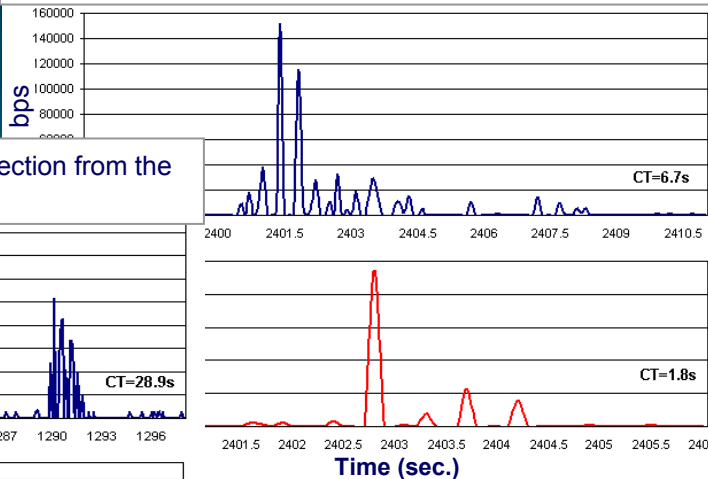

Network convergence time after NE's disconnection from the network [seconds]

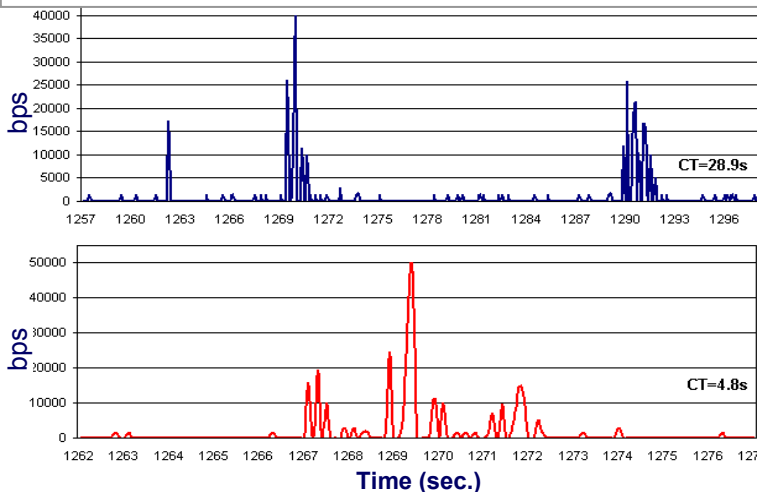

- Selected route

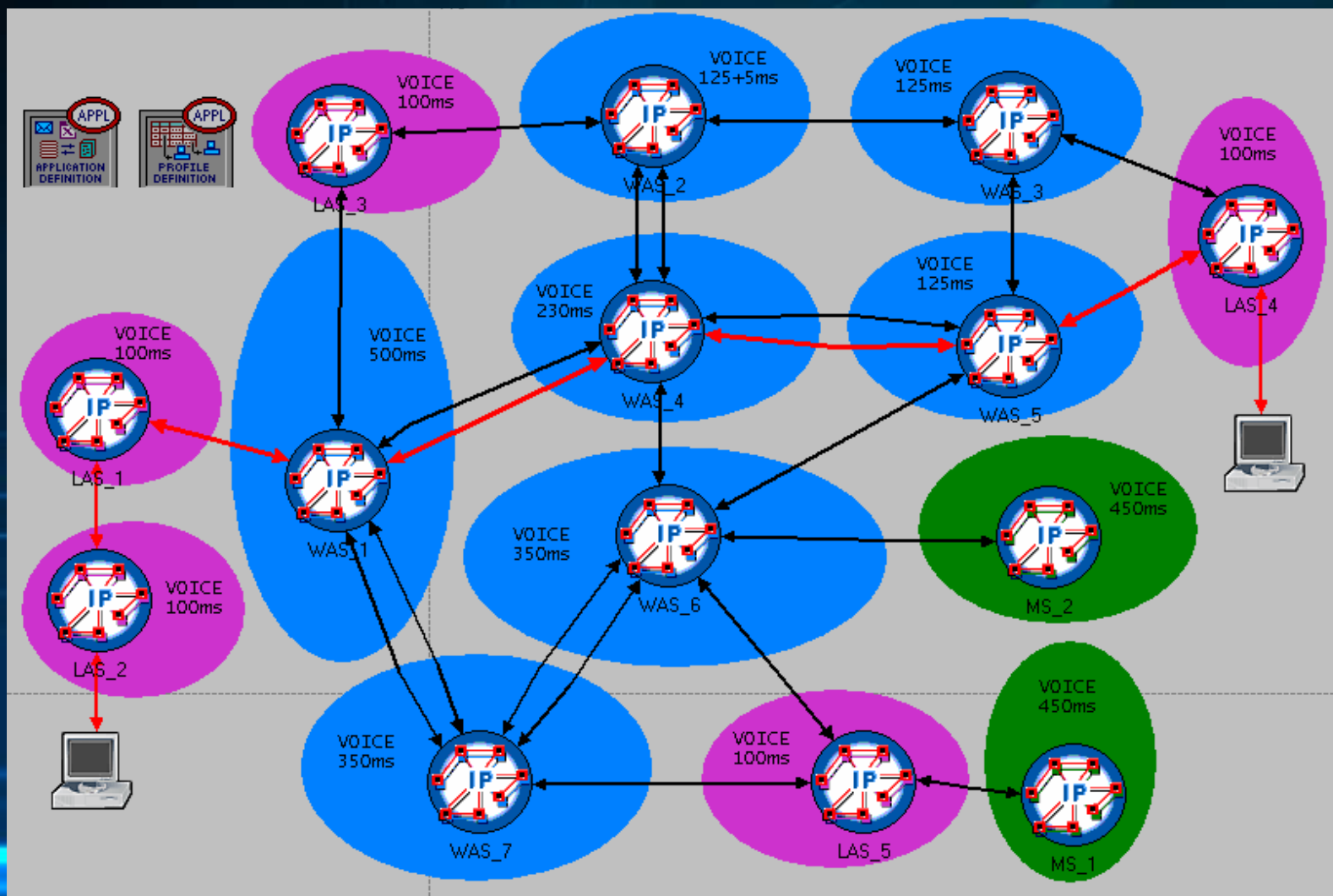



COMPARISON OF RESULTS

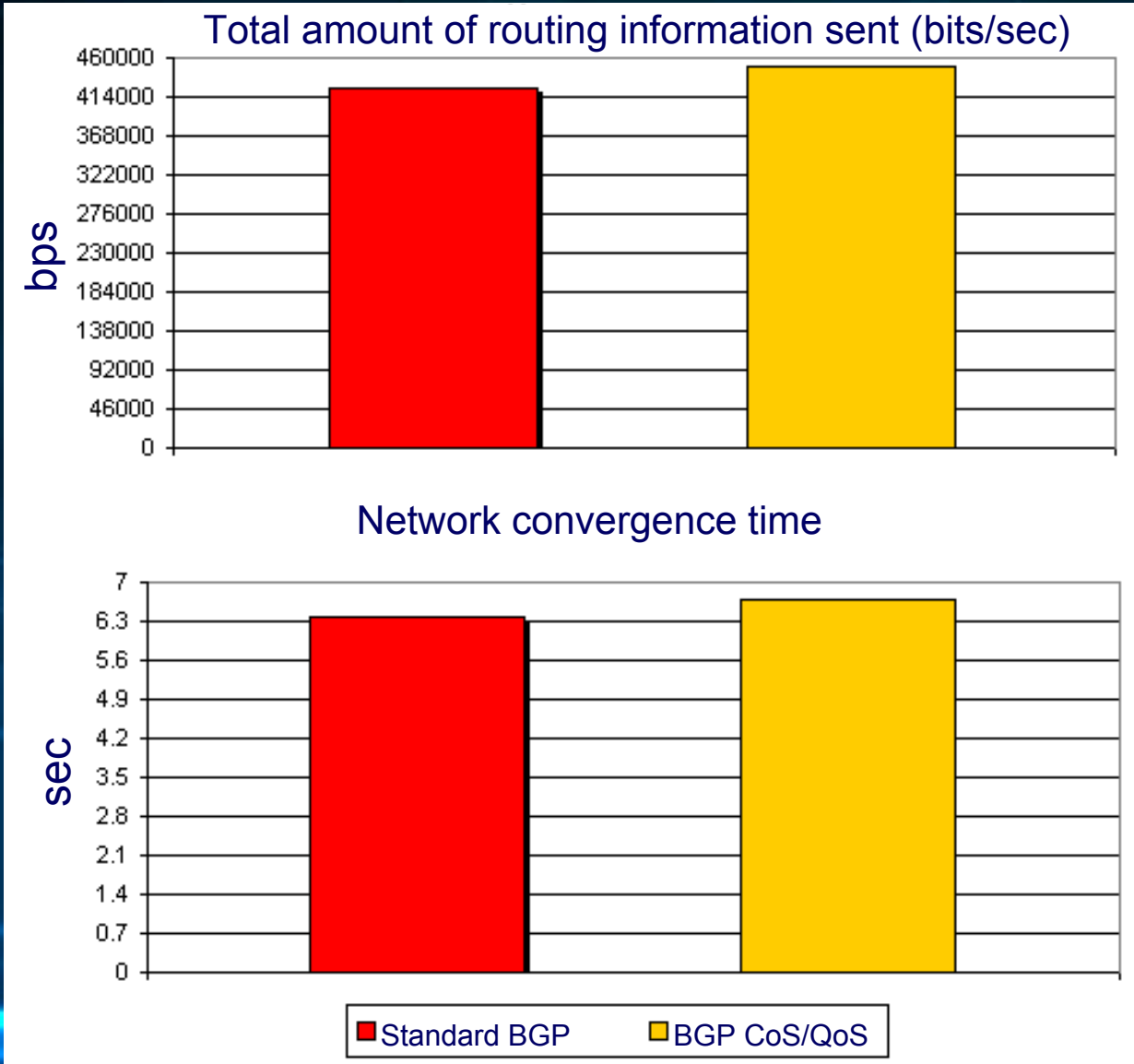



COMPARISON OF RESULTS

- The amount of routing information sent in different situations

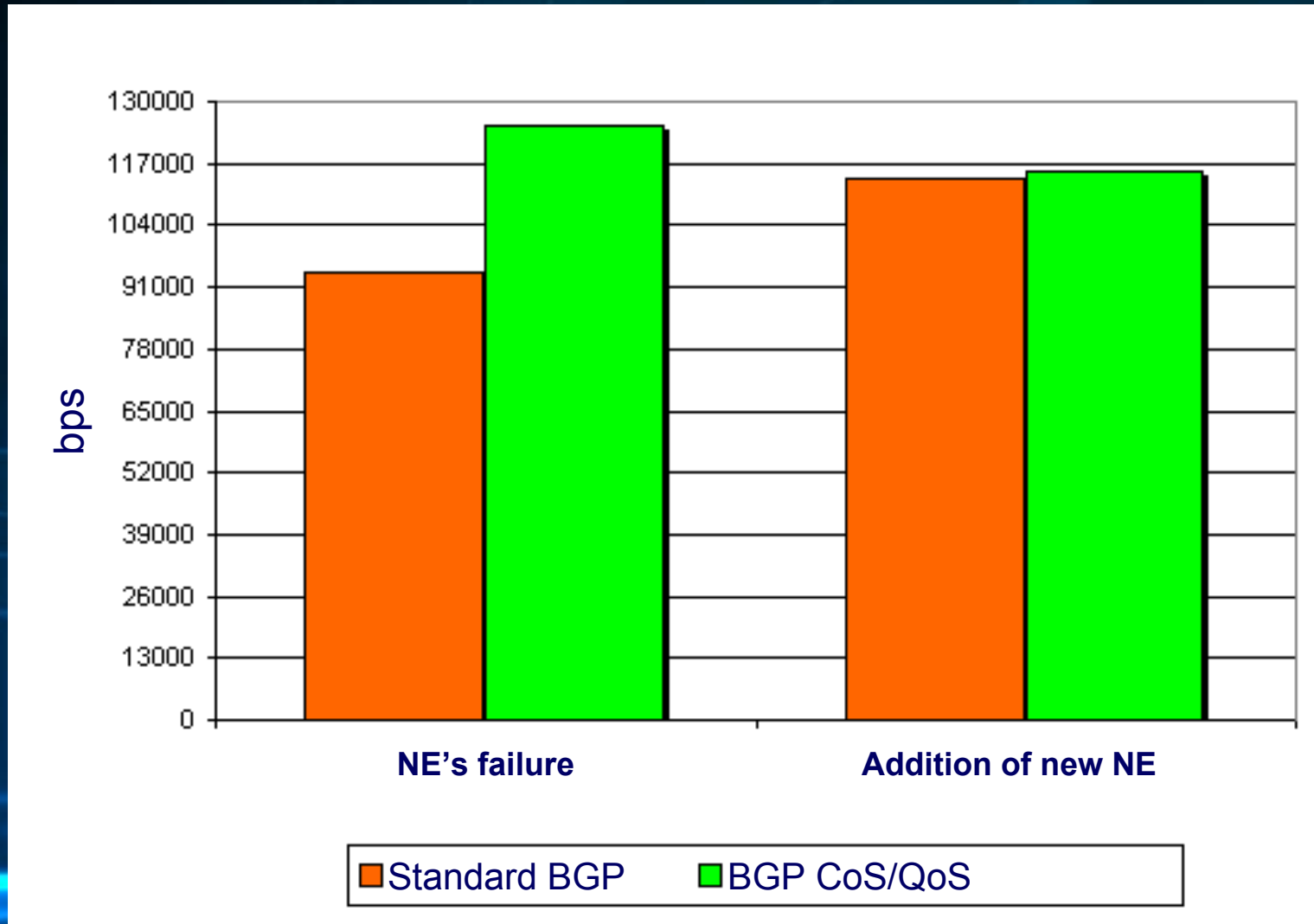

COMPARISON OF RESULTS

- Convergence time in case of network topologies' modifications

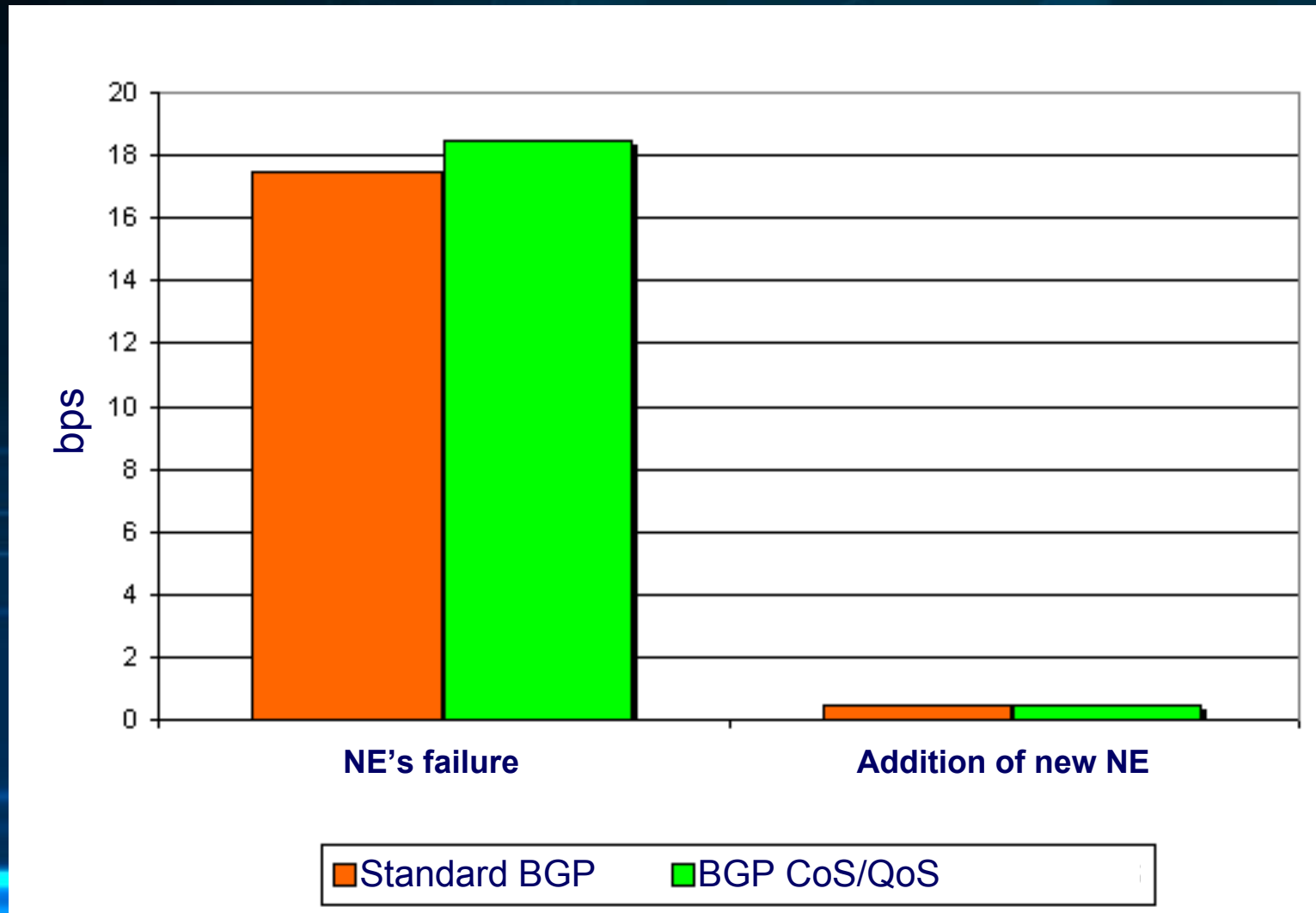

COMPARISON OF RESULTS

- User 1 → user 2 – delay

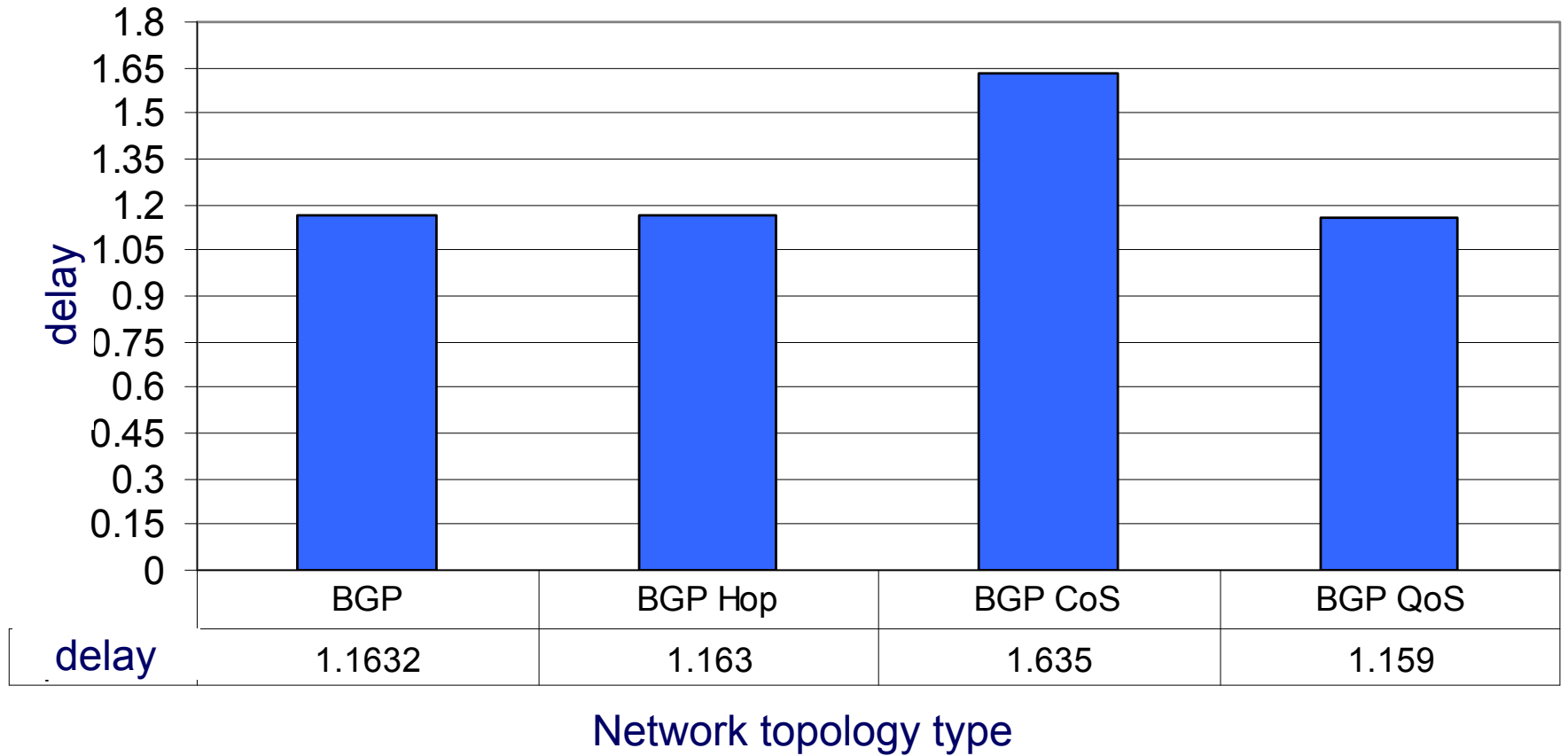



SUMMARY

- Simulation experiments of modified interdomain routing protocol confirmed accuracy of its operation in modeled TP2K network.
- Proposed extensions increase efficiency of BGP protocol – selected route meets requirements included in the call request.
- Proposed BGP with CoS/QoS extensions sends a little bit more routing information (NLRI field is bigger), however it does not overload network resources.
- Network convergence time is related to many factors (network configuration, NE's parameters, modeled situation, etc.), however results' values for extended BGP were only a little bit bigger than for standard BGPv4.



THANK YOU FOR YOUR
ATTENTION