

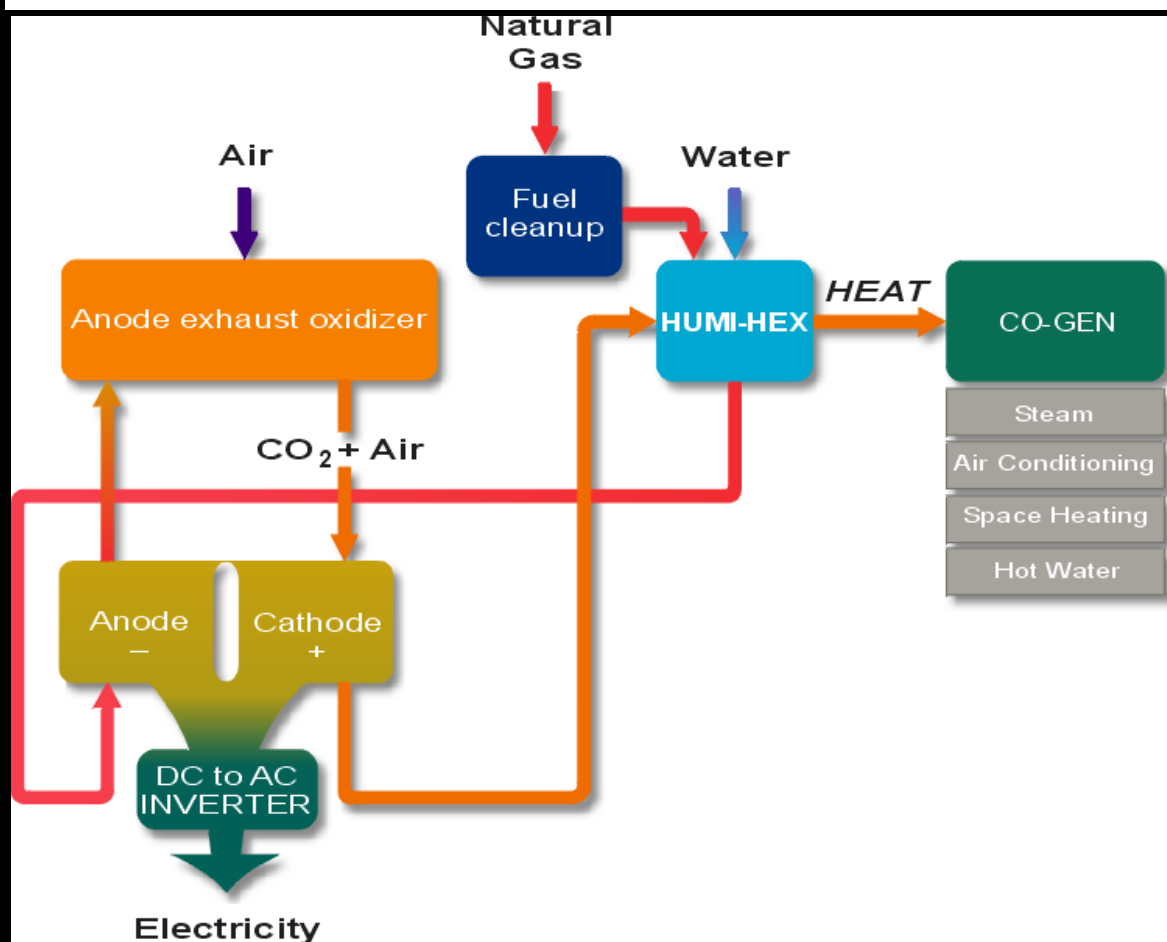

## Molten Carbonate Fuel Cell Operation with Dual Fuel Flexibility

Joseph Daly, George Steinfeld, David K. Moyer, and  
Franklin H. Holcomb

October 2007



# **Molten Carbonate Fuel Cell Operation with Dual Fuel Flexibility**

Franklin H. Holcomb

*Construction Engineering Research Laboratory (CERL)  
U.S. Army Engineer Research and Development Center  
2902 Newmark Dr.  
Champaign, IL 61824*

Joseph Daly and George Steinfeld

*Fuel Cell Energy Incorporated  
3 Great Pasture Road  
Danbury, CT 06813-1305*

David K. Moyer

*Concurrent Technology Corporation  
100 CTC Drive  
Johnstown, PA 15904-1935*

Final Report

Approved for public release; distribution is unlimited.

Prepared for U.S. Army Corps of Engineers  
Washington, DC 20314-1000

Under 2F94KF

**Abstract:** The ability to operate highly-efficient, pollution-free, distributed-generation power plants on either natural gas or HD-5 grade propane is of interest to the U.S. Army and the U.S. Department of Homeland Security as secure power for critical power operations. To address this interest, Concurrent Technologies Corporation (CTC) teamed with FuelCell Energy (FCE) to test an internally reforming 250 kW carbonate direct fuel cell using HD-5 propane. This fuel cell power plant, originally designed to operate on pipeline natural gas or digester gas, was modified for dual fuel operation (natural gas and propane). Fuel cell operation using HD-5 propane was demonstrated for over 3,900 hrs and achieved high electrical efficiency (45.7 to 47.1 percent lower heating value [LHV]) over a broad range of power outputs. In addition, instantaneous and on-load fuel switching from natural gas to propane and back was demonstrated without loss of power. This dual fuel power plant operated efficiently on either fuel and can provide the U.S. Army and other power users with a viable technology solution for critical power operations.

# Contents

<b>Figures and Tables</b> .....	<b>iv</b>
<b>Preface</b> .....	<b>v</b>
<b>Unit Conversion Factors</b> .....	<b>vi</b>
<b>1 Introduction</b> .....	<b>1</b>
1.1 Background .....	1
1.2 Objectives .....	1
1.3 Approach.....	2
1.4 Mode of Technology Transfer.....	2
<b>2 Experimental</b> .....	<b>3</b>
2.1 Fuel Cell Power Plant .....	3
2.2 Power Plant Modification for Propane and Dual Fuel Operation .....	6
2.3 Propane Supply and Delivery.....	7
2.4 Natural Gas Delivery .....	9
2.5 Electrical Connections .....	10
2.6 Gas Sampling and Analysis .....	11
2.7 Calibrations .....	11
<b>3 Results and Discussion</b> .....	<b>13</b>
3.1 Power Plant Efficiency.....	13
3.2 Fuel Flow Control.....	14
3.3 Fuel Swapping .....	16
3.4 Reliability Testing with High Propylene.....	21
3.5 Propane Vaporization.....	22
<b>4 Conclusions</b> .....	<b>25</b>
<b>References</b> .....	<b>27</b>
<b>Acronyms and Abbreviations</b> .....	<b>28</b>
<b>Report Documentation Page</b> .....	<b>29</b>

## Figures and Tables

### Figures

1	Simplified process flow diagram of an MCFC power plant.....	4
2	DFC300A fuel cell power plant operating on propane at CTC .....	5
3	Propane storage and distribution schematic.....	8
4	Gas sample apparatus schematic .....	12
5	Timeline summary of power plant operations .....	14
6	Change in the vapor phase composition as propane tank is depleted for the two major components ethane and propane .....	15
7	Effect of vapor composition change with depleting tank level on equivalent hydrogen, carbon content, and lower heating value .....	15
8	Installed fuel train system allowing delivery of fuels through either a common line or independent lines.....	17
9	Instantaneous fuel swap from natural gas to propane during grid connected operation.....	18
10	Instantaneous fuel swap from propane to natural gas in grid connected operation.....	19
11	Instantaneous fuel swap natural gas to propane in grid independent operation.....	20
12	Instantaneous fuel swap propane to natural gas in grid independent operation.....	21
13	Effect of flow stabilizer on concentrations of total sulfur compounds and methyl disulfide sent to the PDS.....	24
14	Effect of flow stabilizer on high molecular weight sulfur compounds to the PDS .....	24

### Tables

1	Fuel cell energy DFC300A specifications.....	4
2	Power plant modifications for dual fuel operation .....	7
3	Electrical efficiency of the DFC300A fuel cell power plant operating on natural gas and propane .....	14
4	Vapor phase fuel gas composition for standard HD-5 and propylene-spiked HD-5.....	22
5	Preconverter exit compositions for propane and natural gas .....	23

## Preface

This study was conducted for the Office of the Director, Defense, Research, and Engineering (ODDR&E) under “Defense Applications of Stationary Carbonate Fuel Cells.” Language for this project was identified in the 2005 Department of Defense (DOD) Appropriations Bill, House of Representatives Report 108-622, p 262. Funding was made available under Program Element (PE) No. 0602784A; R-28, “Military Engineering Advanced Technology.” provided by the U.S. Army ERDC-CERL. The technical monitor was Robert Boyd, ODDR&E.

The work was preformed by the Energy Branch (CF-E), of the Facilities Division (CF), Construction Engineering Research Laboratory (CERL). The CERL Principal Investigator was Franklin H. Holcomb. Part of this work was done by Joseph Daly and George Steinfield, Fuel Cell Energy Incorporated, Danbury CT, in collaboration with David K. Moyer, Concurrent Technologies Corporation (CTC), Johnstown, PA under Contract No. W9132T-05-C-0033. The DOD’s Fuel Cell Test and Evaluation Center (FC*Tec*) is operated by CTC under Contract No. DACA42-02-2-0001. CTC conducted this work jointly with FCE for ERDC-CERL. Dr. Thomas J. Hartranft is Chief, CEERD-CF-E, and Michael Golish is Chief, CEERD-CF. The associated Technical Director was Martin J. Savoie, CEERD-CF-F. The Director of CERL is Dr. Ilker R. Adiguzel.

CERL is an element of the U.S. Army Engineer Research and Development Center (ERDC), U.S. Army Corps of Engineers. The Commander and Executive Director of ERDC is COL Richard B. Jenkins, and the Director of ERDC is Dr. James R. Houston.

## Unit Conversion Factors

Multiply	By	To Obtain
acres	4,046.873	square meters
cubic feet	0.02831685	cubic meters
cubic inches	0.00001638706	cubic meters
degrees (angle)	0.01745329	radians
degrees Fahrenheit	$(5/9) \times (^\circ\text{F} - 32)$	degrees Celsius
degrees Fahrenheit	$(5/9) \times (^\circ\text{F} - 32) + 273.15$	kelvins
feet	0.3048	meters
gallons (U.S. liquid)	0.003785412	cubic meters
horsepower (550 ft-lb force per second)	745.6999	watts
inches	0.0254	meters
kips per square foot	47.88026	kilopascals
kips per square inch	6.894757	megapascals
miles (U.S. statute)	1.609347	kilometers
pounds (force)	4.448222	newtons
pounds (force) per square inch	0.006894757	megapascals
pounds (mass)	0.4535924	kilograms
square feet	0.09290304	square meters
square miles	2,589,998	square meters
tons (force)	8,896.443	newtons
tons (2,000 pounds, mass)	907.1847	kilograms
yards	0.9144	meters

# **1 Introduction**

## **1.1 Background**

Continuous, long-term operation of a fuel cell on HD-5 propane provides a viable option to islands, remote sites, national parks, data centers, military bases, hotels, and hospitals without a natural gas infrastructure. Although natural gas distribution through utility pipelines is convenient, it is vulnerable to natural disaster, threats of terrorism, and repair outages. Propane provides an alternative local fuel supply routinely transported and stored as a liquid at ambient temperatures and offers a convenient and secure option for fuel cell operations. An adequate quantity of propane can be stored on site to sustain operations for several days pending a fuel delivery or until any natural gas disturbance is restored. The possibility of operating a fuel cell power plant on HD-5 propane, as a back-up to natural gas, provides a valuable proposition for the U.S. Army's initiative to minimize the impact of fuel availability (Appleby 1991; DA 2006; Varbanov et al. 2006).

In response to the interest for a fuel flexible power plant, Concurrent Technologies Corporation (*CTC*), under contract to the U.S. Army Engineer Research and Development Center, Construction Engineering Research Laboratory (ERDC-CERL), worked with FuelCell Energy (FCE) to test a 250 kW carbonate direct fuel cell power plant operating on propane.

The challenges addressed in this demonstration on HD-5 propane included: (1) avoiding carbon deposition during pre-reforming of propane to a methane rich gas, (2) metering and controlling propane flow to account for variations in fuel composition, (3) removing sulfur from the propane, and (4) increasing the steam required for operation on propane. Peripheral issues that required additional investigation included identifying the number and volume of propane tanks needed and a vaporization system to deliver the required fuel delivery rate and operating time.

## **1.2 Objectives**

Prior experience established the operation of a fuel cell power plant on natural gas (Concurrent Technologies Corp. 2005), so the primary objective of this project was to demonstrate HD-5 propane is also a viable fuel for continuous, high power, high efficiency operation of FCE's Direct Fuel



Cell® (DFC®) power plants. This project employed a DFC300A, a 300kW fuel cell power plant with a nominal output of 250kW.

A secondary goal was to demonstrate propane as a back-up fuel to natural gas, with the added benefit of instantaneous fuel swapping from natural gas to propane. This fuel flexibility provides secure power in the event of sudden and unexpected disruption to the natural gas pipeline supply. HD-5 propane, as opposed to other grades of propane, was selected as the back-up fuel of choice based on availability, even in remote areas, and preliminary success processing the HD-5 propane in a full-scale DFC demonstration facility (FuelCell Energy, Inc. 2005).

### **1.3 Approach**

1. Concurrent Technologies Corp. (CTC) was selected to demonstrate and enhance FCE's carbonate DFC operation on HD-5 propane based on that organization's prior experience with the DFC300A power plant, its established credibility, extensive test facilities, and experienced engineering staff.
2. New components and control strategies were designed and implemented to enable the DFC300A to operate on propane and fulfill the need for dual fuel flexibility.
3. The DFC300A fuel cell power plant was operated on HD-5 propane from January through August 2006.
4. During the energy analysis and efficiency review, four electrical connections were independently recorded to monitor electrical parameters allowing accurate and detailed calculations and analyses.
5. Gas analyses were performed on the fuel cell's inlet fuel composition, anode inlet and exit gases, and cathode inlet and exit gases to determine fuel use, establish operating parameters, and investigate problems.

### **1.4 Mode of Technology Transfer**

This report will be made accessible through the World Wide Web (WWW) at URL: <http://www.cecer.army.mil>

## 2 Experimental

Since 1999, *CTC* has operated the 35,000 sq ft Fuel Cell Test and Evaluation Center (*FC Tec*) for the U.S. Army ERDC-CERL. *FC Tec* is recognized as a leading test and evaluation facility for fuel cell systems for both military and commercial applications. The focus of *FC Tec* is to accelerate the development and implementation of advanced power and energy systems through comprehensive research, development, test and evaluation, integration, and optimization services. *CTC* was selected as the optimal location to demonstrate and enhance FCE's carbonate DFC operation on HD-5 propane with the DFC300A power plant, for its established credibility, extensive test facilities, and experienced engineering staff (Concurrent Technologies Corp. 2005).

For the DFC300A to operate on propane and fulfill the need for dual fuel flexibility, it was necessary to design and implement new components and control strategies. To accomplish the system enhancements, a number of key processes and controls were upgraded:

- the desulfurization system
- steam delivery and heat recovery system
- preconverter
- logic and control features.

The following sections discuss power plant modifications and test set-up.

### 2.1 Fuel Cell Power Plant

The power generation technology tested was the DFC technology developed by FCE and currently operating at over 50 locations in the United States, Europe, Japan, and Korea (Brdar et al. 2006; Peltier 2006). The DFC technology uses a Molten Carbonate Fuel Cell (MCFC). MCFC's operate at high temperatures, which allows for the direct reformation of natural gas without the need for an external reformer. Table 1 lists the complete power plant specifications, including the fuel and water consumption, exhaust and water discharge, and emissions information. Figure 1 shows a simplified process flow diagram of a carbonate fuel cell power plant with the key direct fuel cell process components. Figure 2 shows the DFC300A power plant as installed.

**Table 1. Fuel cell energy DFC300A specifications.**

Item	Specification
Net power output	250 kW, 375 kVA
Voltage	480 volt 3-phase alternating current 60 hertz
Net efficiency at rated output	47% lower heating value (LHV)
Heat rate	7,260 British thermal unit (Btu)/kWh LHV
Fuel	Natural gas
Fuel consumption at rated output	32 standard cfm @ 933 Btu/cu ft LHV
Water intake	45 gal/hr (gph)
Water discharge	23 gph
Available heat at rated power	≈ 500,000 Btu/hr
Exhaust temperature	≈ 650 °F
Exhaust flow	3,000 lb/hr
Exhaust back pressure	< 0.18 psi
Noise	65 dB(A) @ 10 ft
Nitrogen oxides (NOx) emissions	0.3 parts per million volume (ppmv)
Sulfur oxides (SOx) emissions	0.01 ppmv
Carbon monoxide (CO)	10 ppmv
Nonmethane organic compounds (NMOC)	10 ppmv

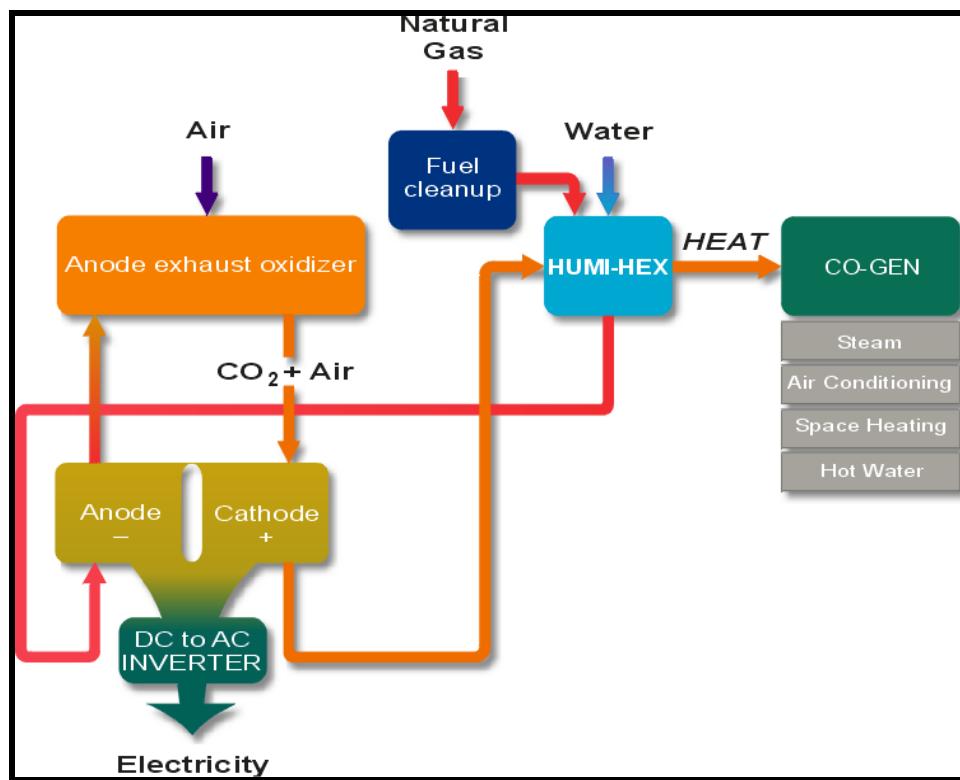
**Figure 1. Simplified process flow diagram of an MCFC power plant.**



**Figure 2. DFC300A fuel cell power plant operating on propane at CTC.**

While most fuel cells use acidic or alkaline media as an electrolyte, carbonate fuel cells are unique in using an electrolyte composed of a mixture of carbonate salts. Two mixtures currently used are lithium carbonate and potassium carbonate or lithium carbonate and sodium carbonate (SAIC 2000); the DFC300A uses lithium carbonate and potassium carbonate, typical of this generation of stacks produced by FCE. Carbonate fuel cells operate in the range 600 to 650 °C to melt and maintain the carbonate salt solution and to achieve high ion mobility through the electrolyte.

When heated to a temperature near 500 °C, the salts melt and become conductive to carbonate ions ( $\text{CO}_3^{2-}$ ). These ions flow from the cathode to the anode where they combine with hydrogen ( $\text{H}_2$ ) to produce water ( $\text{H}_2\text{O}$ ), carbon dioxide ( $\text{CO}_2$ ) and electrons ( $e^-$ ). The electrons are routed through an external circuit back to the cathode, generating electricity and by-product heat. The elemental cell reactions are as follows (Brdar and Farooque 2005):

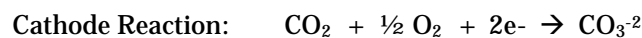

The higher operating temperature of carbonate fuel cells has both advantages and disadvantages compared to the lower temperature phosphoric acid fuel cell (PAFC) and the polymer electrolyte membrane fuel cell (PEMFC). At the higher operating temperature, fuel reforming of natural gas can occur internally, eliminating the need for an external reformer.

The DFC takes advantage of the higher temperature and reforms a methane-rich fuel directly to hydrogen in the fuel cell where it can be immediately consumed.

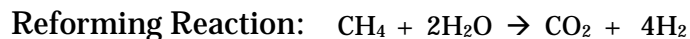

While the electricity producing reaction is exothermic, the reforming reaction is endothermic. Therefore, internal reforming is highly effective at using waste heat and controlling internal fuel cell temperatures. Also, the consumption of  $\text{H}_2$  acts to create more  $\text{H}_2$  by driving the reforming reaction forward to re-establish reaction equilibrium. Therefore, to a large degree, the reforming proceeds nearly to completion and provides  $\text{H}_2$  on an as-needed basis. The high operating temperature of the carbonate fuel cell also provides useable energy for cogeneration when heat recovery is used (Concurrent Technologies Corp. 2005; Peltier 2006; Farooque and Maru 2006).

When operating on propane, the preconverter reactor in the fuel cell power plant converts the propane to a methane-rich gas. The methane is then internally reformed to hydrogen within the fuel cell stack.

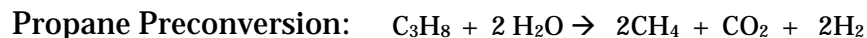

The propane conversion in the preconverter is controlled to create a methane-rich gas preserving the stack cooling by internal methane reforming.

The high temperature operating environment also has disadvantages. The high temperature requires significant time to reach operating conditions. Rapid uncontrolled temperature changes can cause high thermal stresses in the stack, and this has been correlated with stack life reduction. These characteristics make carbonate fuel cells more suitable for stationary, constant-power applications.

## 2.2 Power Plant Modification for Propane and Dual Fuel Operation

The DFC300A power plant was modified to accommodate operation on propane, to maintain the ability to operate on natural gas, and to facilitate rapid fuel switching. Changes included piping and equipment modifications, additional instrumentation, and logic and controls to interpret the new signals and drive the new processes. The data in Table 2 summarize plant changes, which are categorized into fuel train, desulfurization, and preconverter areas.

**Table 2. Power plant modifications for dual fuel operation.**

Addition	Reason
<i>Propane / Dual Fuel Train and Fuel Swapping</i>	
Screen display button and logic to select fuel	Allow automatic or manual fuel selection, indication of fuel currently in use
Transmitter for natural gas inlet pressure	Enable automatic transfer to propane back-up fuel in event of low natural gas pressure
Install parallel flow control valve and flow transmitter downstream of sulfur adsorbent bed	Enable simultaneous flow of natural gas and propane to fuel cell to increase fuel swap options
Add settings to power point set up table and logic to increase steam rate when on propane	Reduce risk of coking in preconverter
On line fuel monitoring	Rapidly adjusts fuel rate depending on fuel composition, e.g., as propane tank is depleted or refilled. Assist with development of instantaneous fuel swapping
<i>Desulfurization</i>	
Change piping to the two desulfurization vessels to dedicate one bed for natural gas and one bed for propane	Desulfurize fuels without blending and cross contamination
<i>Preconverter</i>	
Add anti-coking catalyst upper layer	Anti-coking with propane/propylene
Thermowell with four thermocouples for vertical temperature mapping	Monitor preconverter function and health
Differential pressure measurement	Monitor preconverter function and health
Block valve in fuel line to fuel heat exchanger with associated control logic	Lower preconverter inlet temperature when operating on propane

### 2.3 Propane Supply and Delivery

The HD-5 propane was stored outdoors in two above ground tanks (identified as Tanks A and B) each having a 2000-gal capacity. The usable volume of each tank was about 65 percent of capacity, or approximately 1300 gal; the top 20 percent is reserved for expansion, and the bottom 15 percent is maintained as a buffer to prevent excessive drawdown. When the fuel cell was operating at full load, the usable tank volume lasted approximately 2½ days before automatically switching to Tank B. The DFC300A approximate fuel consumption of 520 gal/day necessitated the tanks to be refilled every 3 to 5 days. Sample ports were strategically located to facilitate both vapor and liquid sampling and subsequent characterization of the fuel supply. Figure 3 shows a schematic of the propane storage and supply system. In addition to the propane storage system, the schematic also identifies: a temporary tanker that was used for propane spiked with propylene, the flow stabilizers initially used for enhanced vaporization, and the interconnecting piping and controls.

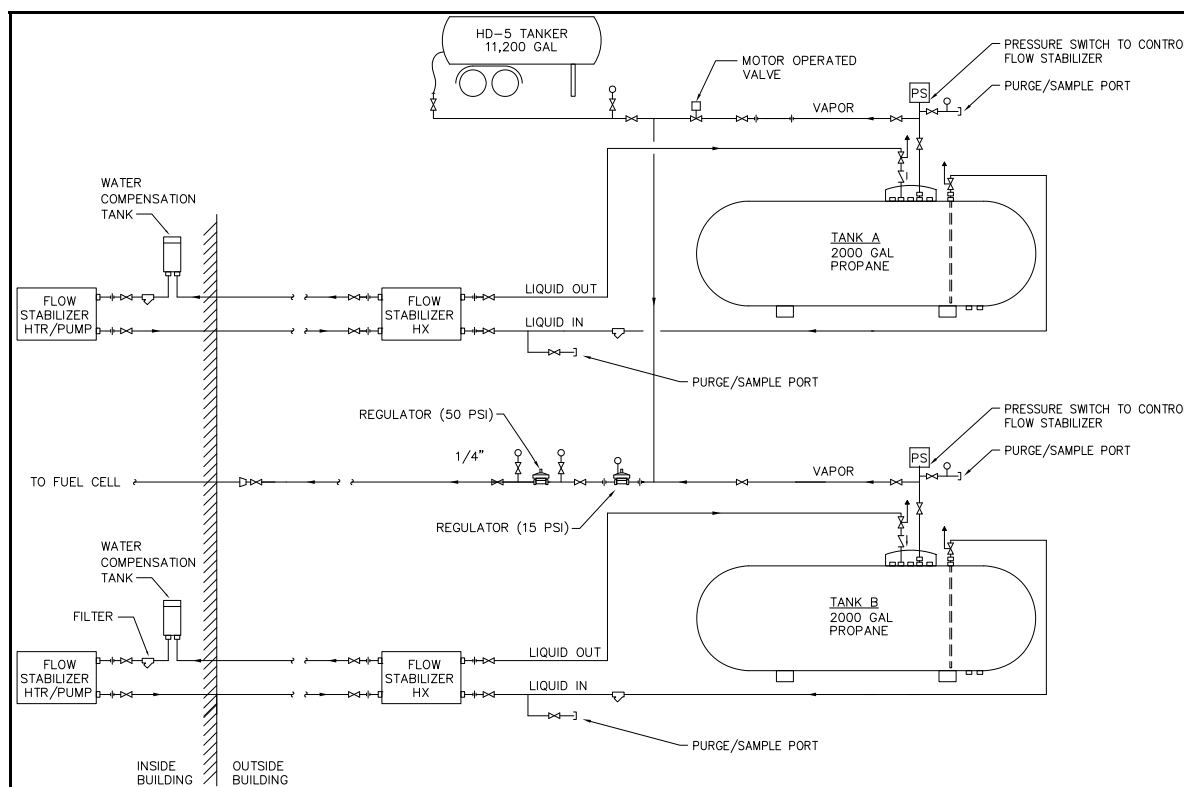

**Figure 3. Propane storage and distribution schematic.**

The initial fuel delivery strategy employed flow stabilizers to maintain propane vapor pressure; initially tanks were drawn down sequentially, first Tank A and then Tank B. Sequential fuel consumption was accomplished with an automated isolation valve on the Tank A vapor output. This valve closed when a remote level sensor on Tank A indicated depletion to approximately 15 percent of capacity. Tank A and Tank B each had independent regulators, with the regulated pressure of Tank A set 2 psi higher than Tank B. In this way, vapor was delivered from Tank A as long as the isolation valve was open, and Tank B would passively begin to deliver flow once the Tank A isolation valve was closed. When Tank A was refilled to greater than 15 percent level, the isolation valve would open and Tank A would once again become the primary fuel source.

The flow stabilizer is activated when the tank pressure falls below 30 psig; a pressure switch (Figure 3) is used to monitor the tank vapor pressure. Low tank pressure is attained when the liquid propane reaches  $-12^{\circ}\text{C}$  by consequence of fuel consumption rate and ambient temperature. The flow stabilizer provides heat to the propane by heat exchange with a heated ethylene glycol-water loop in an external heat exchanger. Thus, the propane liquid is pumped out of the tank cold and returned warm. The flow stabilizers turn off when the tank pressure reaches 40 psig (i.e., a 10 psig

dead band). Although this approach operated as designed, the sulfur concentration increased during flow stabilizer operation. This may have resulted from the warmed liquid being introduced back into the vapor area, allowing increased vaporization of the heavy hydrocarbons and sulfur. A resolution may be to introduce the warmed liquid into the bottom of the tank, hence mixing it with the existing liquid. This methodology was not tested within this effort due to the logistical limitations of making necessary piping modifications while fuel occupied the tank.

To avoid increased sulfur concentration, the fuel delivery strategy was modified to eliminate the flow stabilizers; vaporization from ambient heat only was pursued. In this case both tanks were used in parallel. Use of a common regulator on the vapor output of the two tanks helped assure both tanks maintain the same liquid level. If one tank volume is higher than the other, the higher volume tank will be able to gain heat more readily from the ambient temperature, therefore providing a greater vapor pressure. This will cause the higher volume tank to deliver propane vapor preferentially until its level falls to that of the other tank. This approach proved to be simple and effective. Ambient heat vaporization provided a more consistent fuel supply; however, a sufficiently sized tank or multiple tanks are needed to maintain the required pressure, especially in seasonally cold climate regions.

Per the fuel specification (ASTM 2005), HD-5 propane may contain up to 5 percent propylene, but the HD-5 as received during this demonstration contained very low propylene on the order of 0.1 percent. To create a rigorous test of potential commercial fuel compositions, propylene was added to the stock HD-5 propane to force the concentration of propylene to approximately 5 percent. This propylene-spiked HD-5 was stored in a separate tanker trailer with a capacity of 11,200 gal. The tanker was staged adjacent to the HD-5 storage area and piped into the propane supply and distribution system (Figure 3). When propylene-spiked HD-5 was needed, the valves supplying as-delivered HD-5 propane were closed and the valve to the tanker was opened. The change-over to the 5 percent propylene-spiked propane was performed manually.

## **2.4 Natural Gas Delivery**

Natural gas was supplied through the existing natural gas fuel train. The in-house 5 psig feed flowed through a natural gas compressor system to increase the line pressure to the 15 psig minimum gas pressure required for full load power plant operation. Natural gas compression is not neces-



sary for the DFC300A if a continuous natural gas utility pressure of 15 psig is available at the installation site.

## 2.5 Electrical Connections

A 480Y/277 V 3-phase electrical distribution feeder supplied the necessary DFC300A utility electrical connection. During start up and while operating in hot stand-by, the DFC300A consumed (received) power through this connection. During normal power generation, power was exported (delivered) to the utility electrical grid through this same connection.

The DFC300A also has a customer critical bus (CCB). The CCB remains energized in the event of grid disruption provided the fuel cell power plant is producing power equivalent to or greater than the CCB load. For this demonstration, the CCB provided power to an AC load bank and the natural gas compressor. In commercial application scenarios, the CCB would be connected to critical devices allowing for continued operations during an electric utility disturbance. A separate 480Y/277 V 3-phase electrical distribution panel supplied power to the propane vaporization system, including the two flow stabilizers and the necessary propane level-sensing equipment.

For this test program's energy analysis and efficiency review, each of the four electrical connections presented above (one utility grid connection, two CCB connections, and the propane power panel) were independently recorded to monitor electrical parameters allowing accurate and detailed calculations and analyses.

The DFC300A power plant can operate in grid connect or grid independent modes. During this demonstration, the fuel cell power plant normally was operated in grid connect mode. However, in a simulated grid outage scenario, the DFC300A power plant seamlessly separated from the electrical grid and continued to operate in grid independent mode. In grid independent mode, the power plant needs to produce a minimum of approximately 15 kW AC to support the internal fuel cell power plant parasitic loads. Additional loads of up to 225 kW may also be present on the CCB during a grid outage. Upon grid outage, the power plant load will drop from the grid connect load to the parasitic load plus CCB loads. If the sum of the CCB loads are greater than the previous grid connect load, potentially causing an unacceptable instantaneous rise in fuel cell power plant output upon transition to grid independent mode, or if the fuel supply is interrupted, the DFC300A will safely shut down automatically.

## 2.6 Gas Sampling and Analysis

Gas analyses were performed on the fuel cell's inlet fuel composition, anode inlet and exit gases, and cathode inlet and exit gases. These analyses were used to determine fuel use, establish operating parameters, and investigate problems. The inlet fuel is also analyzed regularly for sulfur content. Sulfur analysis provides a means for estimating the useful life of the desulfurizing adsorbent and indicates the presence of sulfur break-through after the desulfurizer adsorbent becomes depleted.

Most fuel cell reforming processes require water in the form of steam to produce hydrogen for use in the cell stack (Semelsberger et al. 2004; Brown 2001). The DFC power plant is no different; therefore, a significant amount of water vapor is present in the anode gases such as the preconverter, reformer inlet and reformer outlet. During sampling and analysis of these gases, special precautions were taken to prevent water from entering the analytical instruments, e.g., the gas chromatograph (GC) and sensors.

A sample apparatus consisting of a control valve, desiccant bed of drierite, a flow control rotameter, and air-powered vacuum is used to draw gases from each port on the fuel cell. The apparatus is connected to the sample port and plumbed to the GC. Sample gas was first passed through the control valve used to initially control flow. Next, the gas was passed through the desiccant bed to dry the sample. Following the desiccant bed, provision was made to insert a stainless steel sample cylinder to allow for collection of an additional sample for shipment and evaluation at another laboratory. From this connection, the sample was diverted to the GC sample line. Gas samples were collected from the T-connection using the internal sample pump of the GC instrument. The gas next flowed through the rotameter, which indicated the GC sample rate. A target flow of 1 (L/min) was typically used. The flow was adjusted by varying the pressure of the air-powered ejector and by the sample control valve. All gases, including inlet air to the cathode and incoming fuel, were sampled through the apparatus to ensure that completely dry samples were analyzed. (Figure 4).

## 2.7 Calibrations

As an accredited ISO 9001 company, *CTC* is required to perform National Institute of Standards and Technology (NIST) traceable calibrations. *CTC* uses written work instructions for each calibration performed in-house, and as a result, records and keeps all data associated with each calibration.

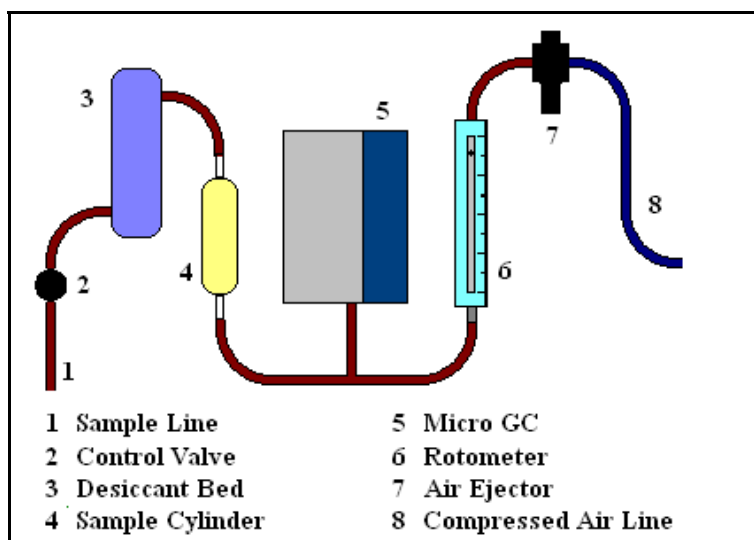

**Figure 4. Gas sample apparatus schematic.**

The calibration system was maintained with a database to ensure that calibration intervals were met for each piece of measuring and test equipment. All *CTC's* outside calibration vendors are required to provide NIST-traceable calibrations and a certificate with "As Found" and "As Left" data so the status of the equipment can be reviewed on its return.

## **3 Results and Discussion**

Operation of the DFC300A fuel cell power plant on HD-5 propane commenced in January 2006 and completed in August 2006. Activities conducted under basic operation reaffirmed that the DFC300A can be operated continuously on HD-5 propane. Figure 5 shows a summary timeline of operations. The operations key at the top of the plot indicates whether operation was on propane, natural gas or fuel swapping between natural gas and propane. During fuel swapping test durations, fuel cell operation continues while the fuel source is switched between natural gas and propane with short durations (hours) on each fuel. Throughout this testing demonstration, the fuel cell was operated on propane for a total of 3,924 hrs, producing 603 MW-h, at a peak output of 250 kW; the fuel cell was operated on natural gas for a total of 1,107 hrs, producing 139 MW-h, at a peak output of 230 kW.

### **3.1 Power Plant Efficiency**

With fuel as the largest contributor in the cost of producing electricity, conversion efficiency is a key characteristic when gauging the value of a fuel cell power plant. Along with little to no pollution and noise, high efficiency is a primary advantage of the DFC system.

A performance test plan was generated for the DFC300A operating on propane based on American Society of Mechanical Engineers (ASME) Performance Test Code-50 (ASME 2002). The test boundary encompasses the DFC300A only. The assumptions associated with this test boundary were: the propane storage at any proposed site would be sufficient to support full load operation for the duration between propane tank refills regardless of temperature, and natural gas is available at a pressure of 15 psig or higher from an existing local utility supplier (i.e., compressor/electrical load to raise natural gas pressure is not required). Table 3 lists the test results and indicates that the efficiency of the fuel cell with HD-5 propane is high at 45.5 to 47.1 percent LHV and is maintained over a wide range of power output. This efficiency is comparable to typical efficiency with natural gas.

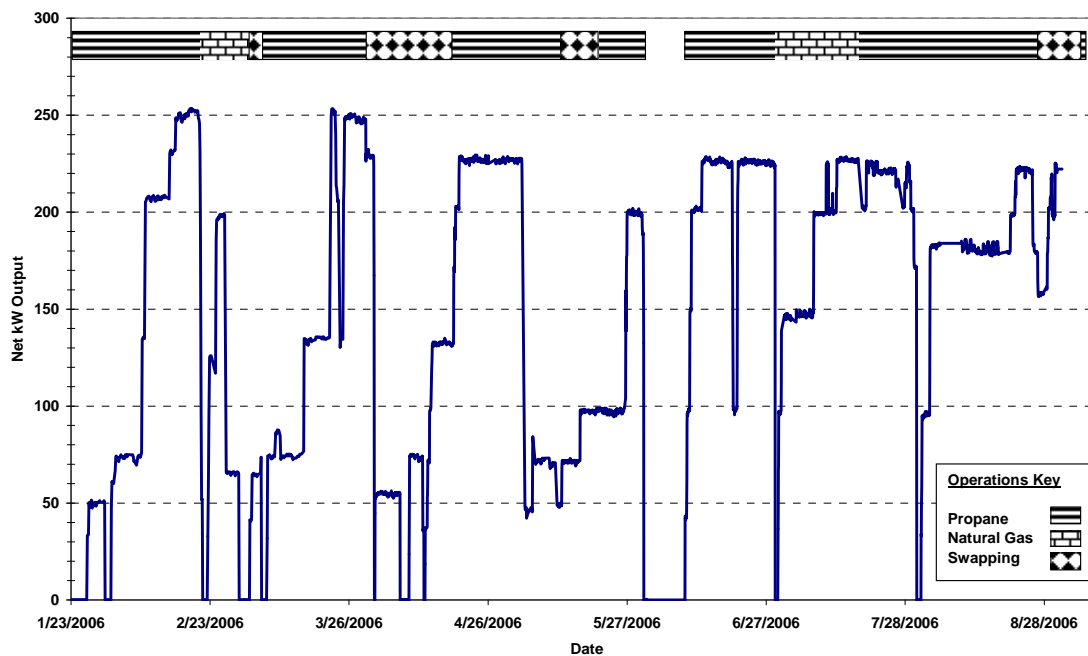

**Figure 5. Timeline summary of power plant operations.**

**Table 3. Electrical efficiency of the DFC300A fuel cell power plant operating on natural gas and propane .**

Power Level	Determined Plant Efficiencies* (% LHV)	
	Natural Gas	Propane
½ Load (~130 kW)	44.5 %	47.1 %
¾ Load (~ 200 kW)	47.0 %	46.1 %
Full Load (244 kW)	46.5 %	45.7 %
* Natural gas efficiency determined during previous project (Concurrent Technologies Corp. 2005). Propane efficiency was determined during this project.		

### 3.2 Fuel Flow Control

For this demonstration, the HD-5 propane flow rate was metered with a thermal mass flow meter. This flow metering methodology required some compensation, however, because thermal mass flow meters do not adjust entirely for the change in fuel composition that occurs as the propane tank is depleted and refilled. Initially, the vapor delivered from the tank contains ethane/propane/butane in percentages in the range of 12/88/0, respectively. As the tank is depleted, this vapor composition can shift to 0.4/99/0.6. Figures 6 and 7 show the propane composition variation and its effect on the hydrogen content and carbon content of the fuel. Figure 6 shows the variation of ethane and propane concentration in the vapor as the propane tank is depleted, and Figure 7 shows the effect on the fuel gas lower heating value, hydrogen equivalents, and carbon equivalents.

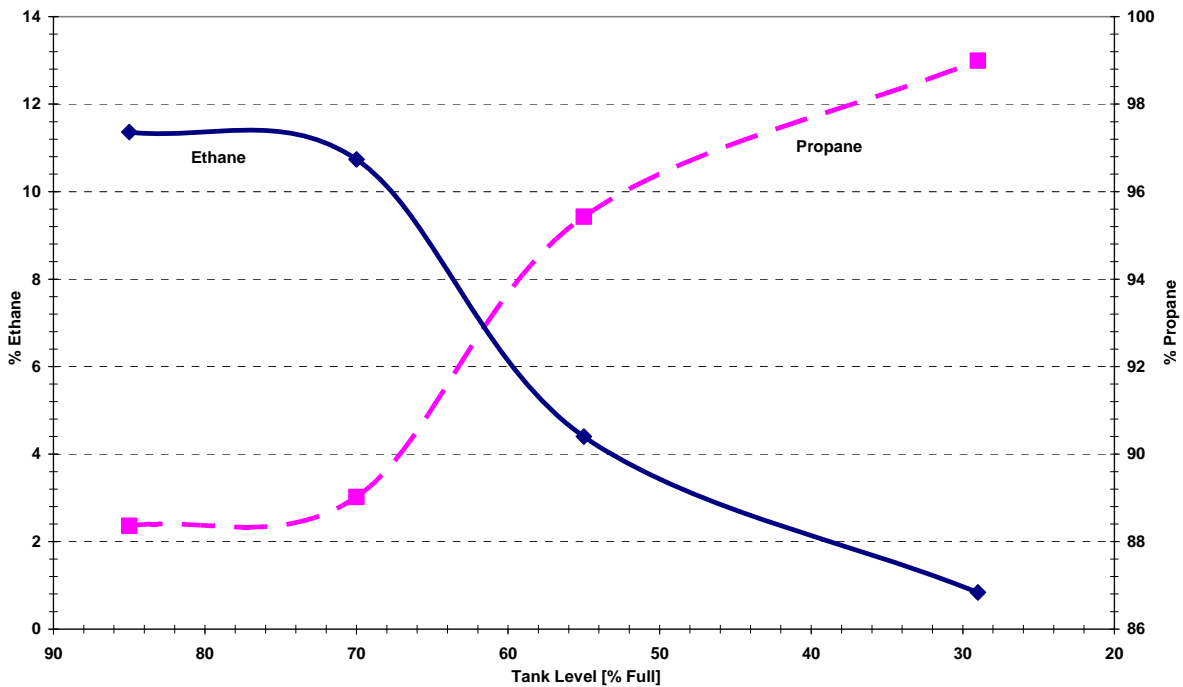

**Figure 6. Change in the vapor phase composition as propane tank is depleted for the two major components ethane and propane.**

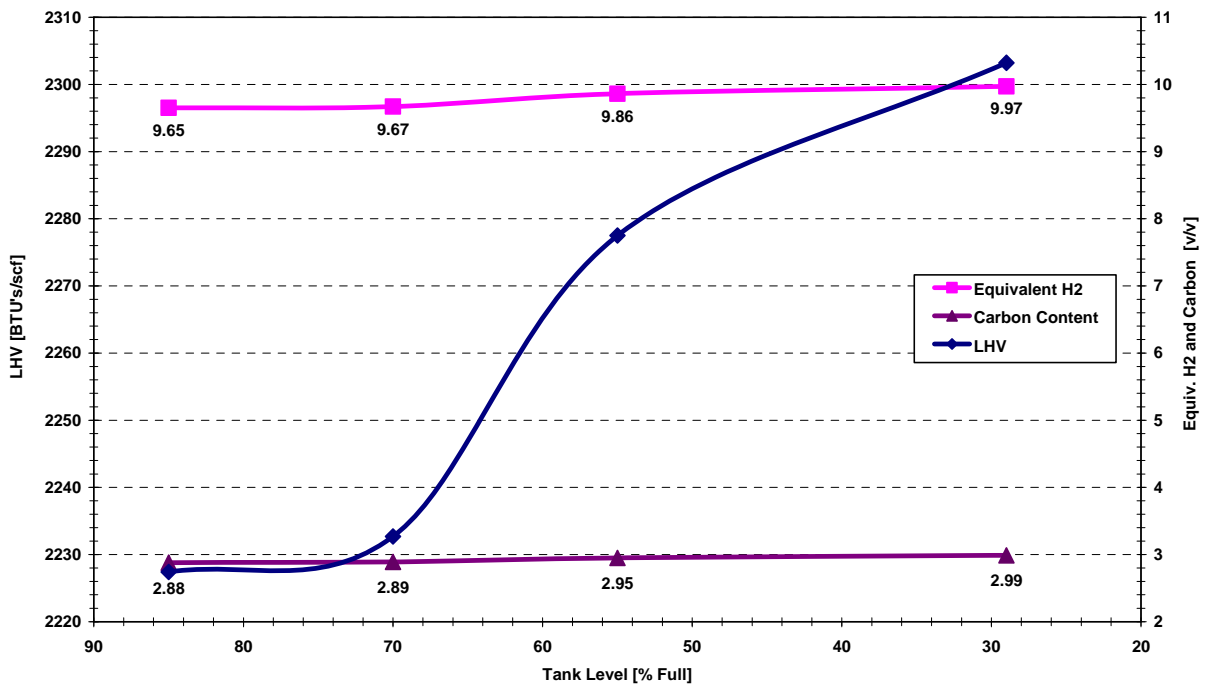

**Figure 7. Effect of vapor composition change with depleting tank level on equivalent hydrogen, carbon content, and lower heating value.**

Thus, depletion of the tank results in a gradual change in composition, followed by an abrupt shift as the tank is refilled. Due to this change in composition, the fuel supplied to the power plant will be hydrogen poor when the tank is full and will become hydrogen rich when the tank is depleted. To maintain peak power plant efficiencies, and to manage heat within the process, it is important to maintain the correct fuel flow rate in terms of hydrogen equivalents entering the fuel cell. Based on in-situ analysis of fuel cell process gases, a process was implemented to trim the fuel flow set point to maintain constant fuel value despite the changing composition.

### **3.3 Fuel Swapping**

Two methods of fuel transfers were considered for this test demonstration: gradual and instantaneous. In the gradual transfer method, propane is added slowly as equivalent natural gas is removed. Gradual fuel transfers take several minutes to perform when the plant is on high load (King County and CH2MHill 2007). In the instantaneous method, the natural gas is instantaneously swapped for the propane back-up fuel. The instantaneous swap carries significant advantages over the gradual swap for secure power applications. For example, the natural gas supply pressure may fall rapidly, necessitating an equally rapid transfer to the back-up fuel. Furthermore, loss of fuel may occur during a grid outage, in which case the power plant would have to operate in grid independent mode. In this situation, the power plant must continually supply power to support critical bus power needs, and this in turn demands a constant flow of fuel to the fuel cell.

With these significant advantages to the instantaneous swap, the challenge to this project became one of demonstrating the instantaneous fuel transfer on high load, in grid independent mode. This achievement demanded detailed information about the actual flow of fuel to the stack, during which an instantaneous fuel swap is affected not only by the fuel transition itself, but also by the rapidly changing steam rate. This detailed information came from the in-situ analysis of fuel cell process gases, which provided a second-by-second update on the quantity of fuel entering the fuel cell. This approach was paramount in evaluating the success of the instantaneous swap, and it led to rapid development of instantaneous fuel swapping at high loads with little or no drop in load.

The instantaneous fuel transfer could only be achieved by the use of a common fuel train. Previous work required two independent fuel trains, one dedicated for each fuel (King County and CH2MHill 2007). In making

the power plant modifications for dual fuel, the possibility of fuel transfer in either mode was built into the design (Figure 8). The test plan called for first attempting the instantaneous fuel transfer, but if control or other issues arose, the demonstration could fall back on the gradual fuel transfer option. As Figure 8 shows, for the instantaneous fuel transfer, the “hop-over” valve would be open, and only one of the two fuel trains would be used. For example, assume the FT-817/FV-817 fuel train is in use for controlling natural gas flow. At the time of instantaneous fuel swap, the fuel selection valves would simultaneously close off the natural gas flow and open up the propane flow. Flow control continues with the FT-817/FV-817 fuel train, now controlling propane. If the hop-over line is closed (Figure 8), then the two fuel trains become independent, where one is used for natural gas and the other is used for propane. This would allow for fuel blending during the gradual transfer from one fuel to the other, where both fuels are controlled simultaneously and independently.

The instantaneous fuel transfer systems and logic were first tested at no load and followed by progressively increasing load levels. With the completion of each successive test, logic evolved and testing progressed to the next higher load fuel swap. Initially, the power plant would momentarily drop load, but analysis of the data and refinement of control parameters led to rapid fuel swapping at high loads with little or no drop in load. During this demonstration, 42 instantaneous fuel transfers were performed at loads below 180 kW, and 22 instantaneous fuel transfers were performed at loads above 180 kW.

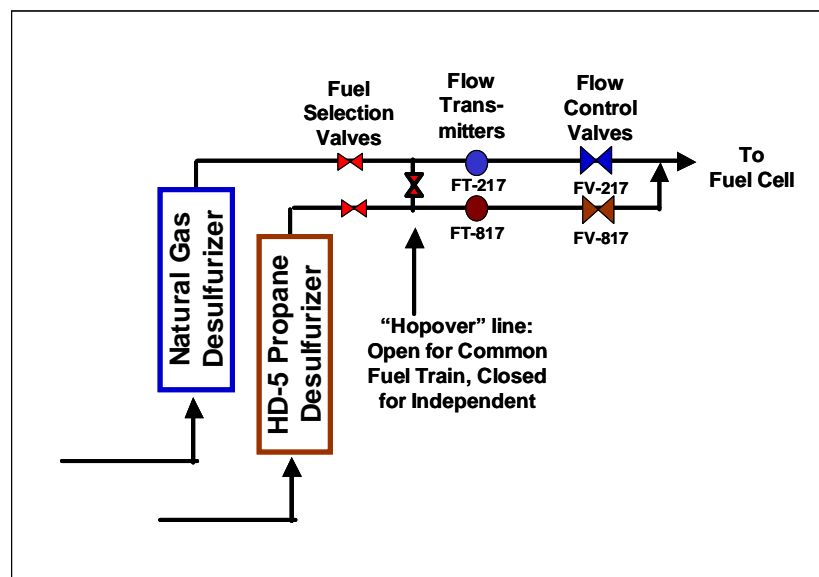
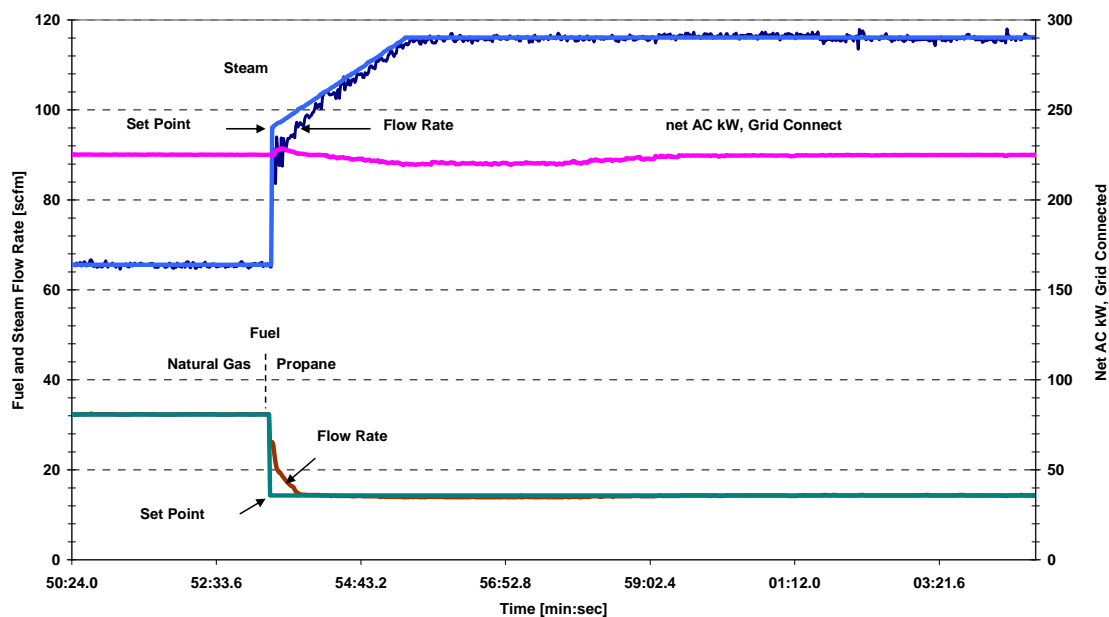

**Figure 8. Installed fuel train system allowing delivery of fuels through either a common line or independent lines.**



The successful transfer from natural gas to propane was designed to occur without any forewarning; as the natural gas supply pressure falls below a pre-set trigger point, the swap from natural gas to propane occurs automatically. In the midst of the fuel transition, the steam flow rate increases to protect the preconverter from carbon formation. If the required steam is not present, the control system will reduce the fuel flow rate set point. As a cascading effect, if the fuel flow rate is not sufficient, the fuel cell power output will be limited. However, improvements were made by increasing the rate of steam addition and decreasing the rate of fuel so that the new set point is achieved without a drop in output.

Figure 9 shows fuel and steam parameters as the fuel is swapped from natural gas to propane with no loss in load. At the point of fuel transition, the fuel flow set point takes a step change to the new lower value for propane. Based on fuel flow controller response, the actual fuel flow rate rapidly approaches and then achieves the set point flow. The steam flow rate is increased, first with an instantaneous step change in flow rate set point and then with a ramping set point. The magnitude of the step change, and subsequent ramp rate, were carefully selected and developed during the testing to assist with successful instantaneous fuel swap with no loss in power output. Steam flow rate and rate of change are important parameters because the steam plays a major role in the velocity of the existing fuel inventory entering the fuel cell.



**Figure 9. Instantaneous fuel swap from natural gas to propane during grid connected operation.**

Figure 10 shows the fuel and steam flow rates as the fuel is swapped from propane back to natural gas; again, there is no loss in load during the fuel transition. To maintain constant load while the fuel transitions from propane to natural gas, the fuel flow rate must be rapidly increased 250 percent. For this fuel transition the steam flow rate must gradually reduce. The actions on the steam flow rate were carefully selected to align with providing relatively constant fuel flow to the fuel cell during the fuel transition. As both Figures 9 and 10 show, fuel swaps were demonstrated on high load with no significant variation in power output while the plant was in grid connect mode. This provided confidence for success with such transfers in grid independent mode.

In terms of power quality, a momentary reduction in power output while the power plant is grid connected would have no effect on a customer; because in this case the line voltage is supplied by the electric utility grid. On the contrary, in grid-independent mode, the power plant must maintain the nominal line voltage by drawing the required power from the fuel cell. If the power plant detects that the load is too great, for example, the fuel cell voltages are decreasing, then the power plant will automatically shut down. With greatly reduced risk of shutting down the plant during testing and development, instantaneous fuel swaps were developed through testing in grid connect mode. After satisfactory results were achieved in grid-connect mode, instantaneous swaps were demonstrated in grid independent mode.

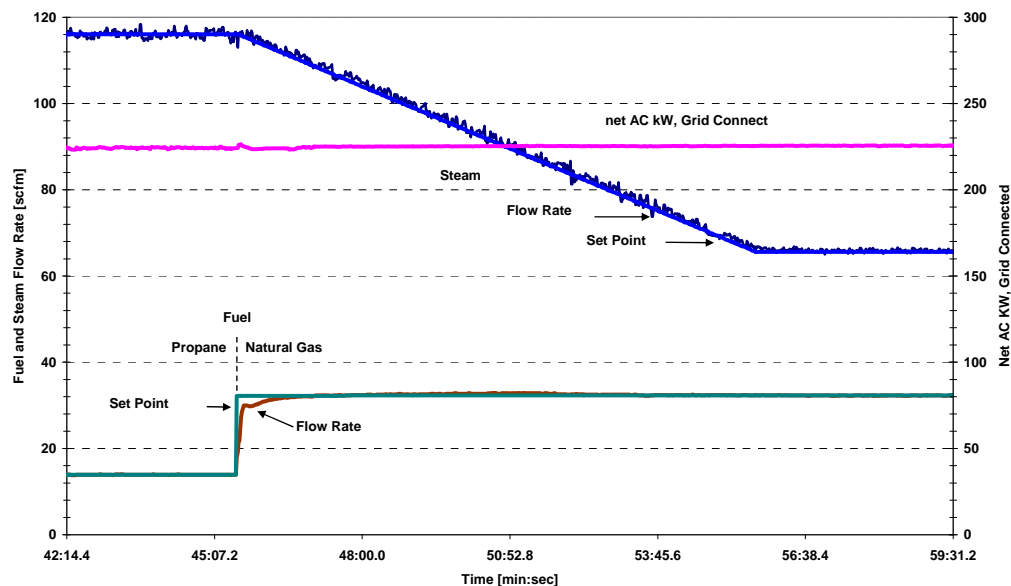

**Figure 10. Instantaneous fuel swap from propane to natural gas in grid connected operation.**

Figures 11 and 12 show the instantaneous fuel swaps in grid-independent mode, natural gas to propane, and propane to natural gas, respectively. These figures mirror the same instantaneous swaps shown in Figures 9 and 10 for grid independent mode; the logic and controls are the same in both cases. The only perceivable difference may be in power output. In grid connect mode, the power output is controlled by the fuel cell power plant, as based on a number of factors such as fuel flow rate. In grid independent mode, the power output cannot be controlled by the fuel cell power plant. The power output may vary if the load on the critical bus or power plant parasitic loads varies. According to Figures 11 and 12, the power output did not vary, and therefore the critical bus and power plant parasitic loads did not vary during the brief periods shown in the figures.

Switching back from propane to natural gas is much simpler because excess steam is present, so there are no limitations to the natural gas flow rate set point. Furthermore, this is an operator-selected action, which is done deliberately and with forewarning, presumably when the utilities are otherwise secure and the power plant is grid connected. Since the natural gas flow rate is about 2.5 times greater for equal power output, there can be some drop in power until the flow rate reaches the new set point. Due to the propane inventory in the fuel train, the power output will remain high for the few seconds required for the natural gas fuel to achieve set point, therein eliminating any drop in the system power.

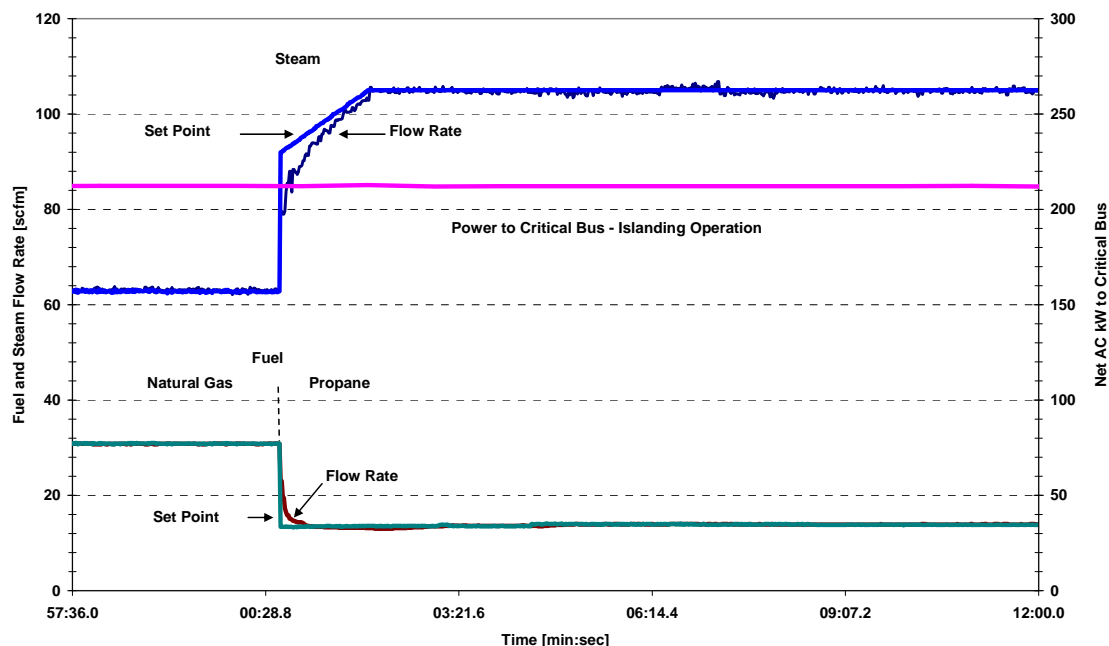

**Figure 11. Instantaneous fuel swap natural gas to propane in grid independent operation.**

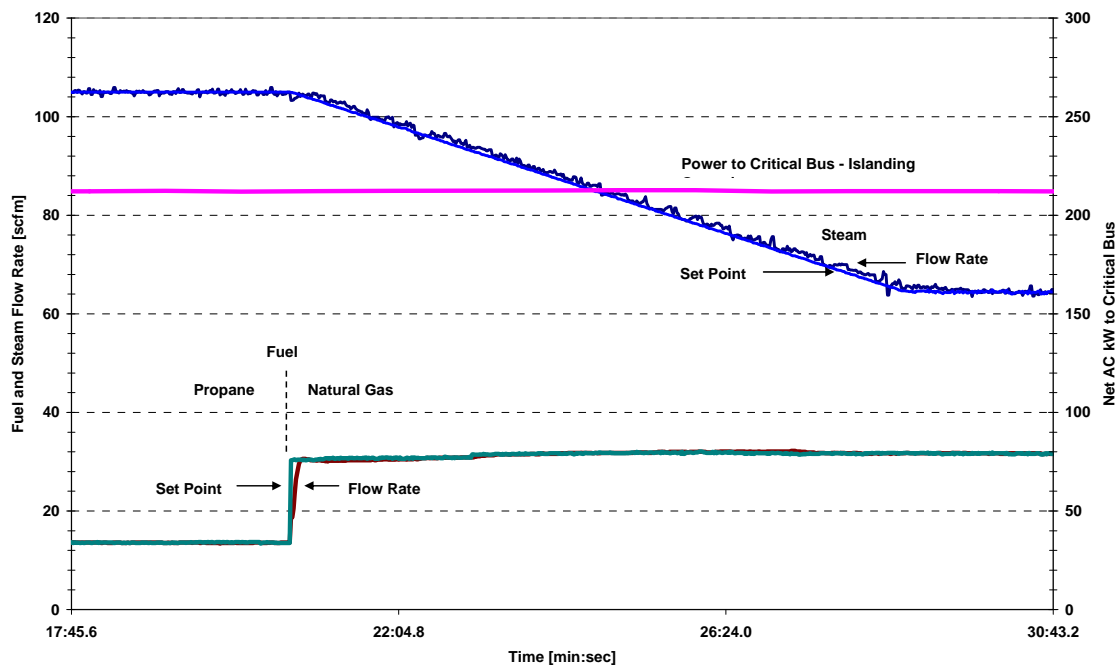

**Figure 12. Instantaneous fuel swap propane to natural gas in grid independent operation.**

### 3.4 Reliability Testing with High Propylene

The most challenging preconverter test occurs when the HD-5 contains the maximum propylene. HD-5, by name and by specification, may contain up to 5 percent propylene. However, the HD-5 as received, contained very little propylene, on the order of 0.1 percent propylene. Propylene in the HD-5 is expected to have greater potential for carbon formation in the preconverter than propane. Therefore, after 4 months of successful operation on the low propylene concentration HD-5, as a test of the preconverter robustness, the plant was operated on HD-5 spiked with propylene to bring the concentration to 5 percent. Table 4 lists an example analysis of the composition of the vapor sent to the power plant for both the standard HD-5 and the propylene-spiked HD-5. Surprisingly, the concentration of aromatic hydrocarbons was greater in the standard HD-5 than in the propylene-spiked HD-5, totaling 1.4 percent vs. 26 ppm respectively. Aromatic hydrocarbons also impose an increased burden on the pre-reformer and increase the risk of carbon formation, but the higher propylene content potential (5 percent) presents a greater risk. The difference in ethane content is attributed to tank level at the time of sampling. The two types of HD-5 came from two different suppliers, which explains the difference in composition between the HD-5 and propylene spiked HD-5.

**Table 4. Vapor phase fuel gas composition for standard HD-5 and propylene-spiked HD-5.**

Component	HD-5	HD-5 Spiked with C3H6
	Concentration (%)	
Methane	0.180	0.000
Ethane	0.360	3.606
Ethene	0.000	0.000
Propane	94.670	88.330
Propylene	0.100	6.264
iso-butane	n/a	0.181
Butanes	3.190	1.269
Iso-Pentane	n/a	0.000
Pentane	n/a	0.003
Pentene	n/a	0.292
Hexane	n/a	0.000
Hexene	n/a	0.000
<b>Aliphatic Hydrocarbons:</b>		
C6 Range	0.188	0.013
C7 Range	0.207	0.009
C8 Range	0.103	0.002
C9 Range	0.028	0.001
C10 Range	0.014	0.002
C11 Range	0.005	0.002
C12-C14 Range	0.000	0.000
<b>Aromatic Hydrocarbons:</b>	(ppm v/v)	
Benzene	13000	9
Toluene	610	3.4
Ethylbenzene	110	1.7
m+p Xylenes	350	7.8
o-Xylene	130	3.9

The plant was run on the propylene-spiked HD-5 for a total of 27 days with the same preconverter catalyst. The preconverter performed well prior to, during, and subsequent to the operation with HD-5 having approximately 5 percent propylene. The preconverter pressure drop and internal temperatures were stable; the exit gas composition remained stable and was practically free of higher hydrocarbons, and the percent reformed remained consistent. The data in Table 5 may be used to compare the preconverter function when using propylene-spiked HD-5 to normal HD-5, as well as natural gas. Samples of preconverter catalyst were taken for analysis at the end of the test period. The analysis indicated normal activity with normal carbon and sulfur content, providing confidence that DFC power plants can be operated with HD-5 having up to 5 percent propylene.

### 3.5 Propane Vaporization

Propane consumption to produce a continuous 250 kW output is approximately 520 gal/day of HD-5. To achieve the required vapor pressure of 15 psig, the temperature of the liquid in the tank must be warmer than -23 °C. To support this vaporization rate on a continuing basis using a single 2000-gal propane tank, it was found that the ambient temperature needed to be about 5 °C or above.

**Table 5. Preconverter exit compositions for propane and natural gas .**

Fuel	HD-5	HD-5 with Propylene	Natural Gas
Date	7/21/2006	7/25/2006	7/17/2006
Power	225 kW	220 kW	225 kW
Percent Reformed	8.2%	8.6%	5.4%
Composition (%)			
H2	21.22	22.33	17.77
CH4	59.06	59.00	77.78
CO	0.37	0.00	0.17
CO2	18.82	19.70	5.44
Ethane	0.02	0.02	0.03
Propane	0.31	0.47	0.00

Vaporization is achieved at lower ambient temperatures by using two or more 2000-gal tanks in parallel. Also, maintaining a higher fill level in the tank allows for higher vaporization rates at a given ambient temperature, due to increased wetted surface area available for heat transfer from ambient air to propane liquid. The 11,200-gal tanker used during propylene-spiked HD-5 testing supported full load operations without the need for external heating.

Vaporizers and flow stabilizers are commonly used in propane field applications where low temperatures are anticipated to impede the natural vaporization process. However, the propane operations indicated that both of these vaporization methods caused increased levels of high molecular weight sulfur compounds in the vapor phase, which can compromise the low temperature sulfur removal system.

In one series of tests, the flow stabilizer was turned on for a 5-hr period while the effect of sulfur compounds was closely monitored. As shown in Figure 13, the results of that diagnostic test confirmed that the flow stabilizer causes high levels of sulfur, and most of the sulfur consists of high molecular weight compounds. Figure 14 shows a snapshot view of this data. As these figures show, operation of the flow stabilizer caused sulfur levels entering the propane desulfurizing system to increase from 26 parts per million (ppm) to 60–80 ppm over a 2½-hr period. More importantly, very high molecular weight sulfur compounds that were low in concentration with the flow stabilizer shut off became prevalent, increasing 30 times in concentration from 0.5–0.7 ppm to 19–21 ppm. When the flow stabilizer was again shut off, the concentration of all high molecular weight sulfur compounds subsided. Therefore, for high, continuous draw rates and cold ambient temperatures, adequate storage size or an external tank heater is suggested to provide the required flow rate without carryover of the increased high molecular weight sulfur compounds.

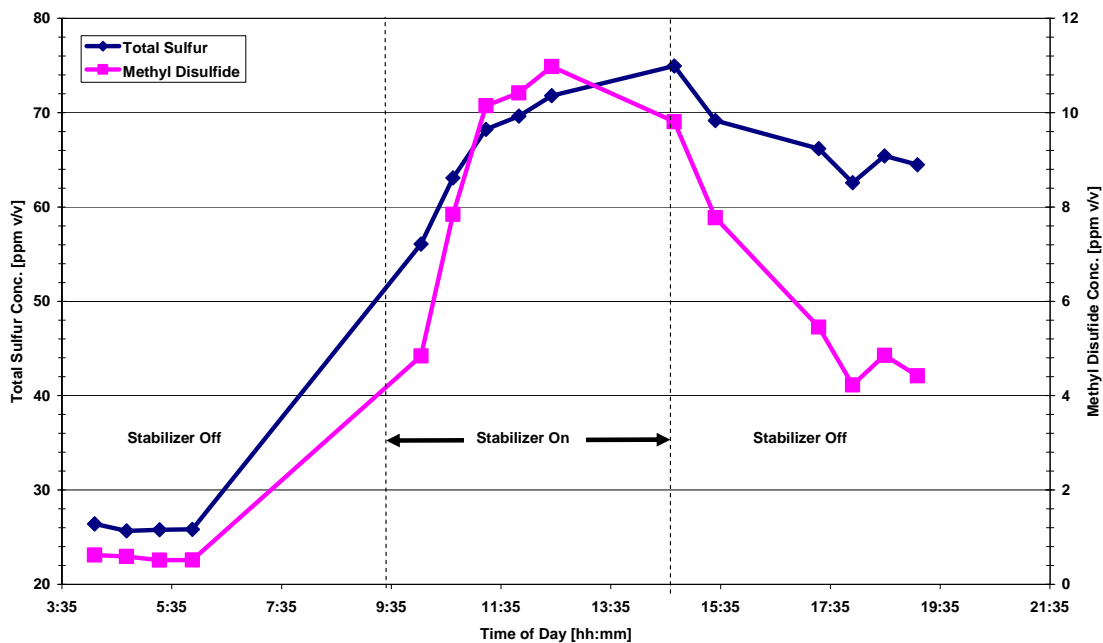

**Figure 13. Effect of flow stabilizer on concentrations of total sulfur compounds and methyl disulfide sent to the PDS.**

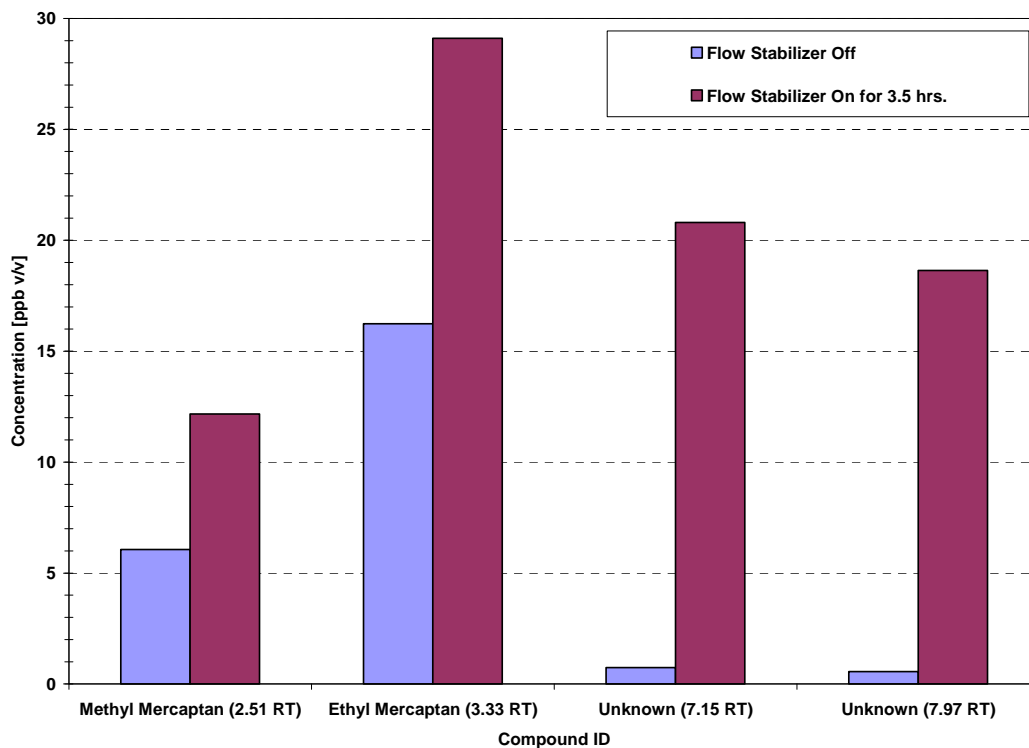

**Figure 14. Effect of flow stabilizer on high molecular weight sulfur compounds to the PDS.**

## 4 Conclusions

This test program demonstrated for the first time that an FCE DFC300A commercial fuel cell power plant, normally operated on natural gas or digester gas, can be operated on HD-5 propane at high load for long-term, high efficiency power production. The results also confirm the ability to make instantaneous fuel swaps between natural gas and propane (as a back-up fuel to natural gas) while operating on load in both grid connected and grid independent modes. During this demonstration period, the power plant accumulated over 3,900 hrs of propane operation, generating 603 MW-h of electricity. In addition, operations on natural gas accumulated over 1,100 hrs and generated 139 MW-h during this period.

Operation of the DFC300A fuel cell power plant has demonstrated new approaches to the main technical challenges associated with operating on propane:

1. Avoiding carbon deposition during pre-reforming of propane into a methane rich gas
2. Metering and controlling propane flow to account for variations in fuel composition
3. Removing sulfur from the propane
4. Increasing the steam flow required for operation on propane.

Fuel Cell power plant efficiency during propane operation was independently measured by *CTC*, with third party gas analysis, at part load and full load. Efficiency was found to be in the range of 45.7 percent to 47.1 percent (LHV) and was maintained over a wide range of power output. This efficiency is comparable to typical efficiency on natural gas.

Instantaneous fuel swapping was conducted in both grid-connect and grid-independent modes. In grid-connect mode, instantaneous high load fuel swaps were demonstrated with only minor and momentary reductions in load. In grid independent mode, instantaneous high load fuel swaps were demonstrated with no variation in critical bus voltage, and full support of the critical bus load. This shows that propane can be used as a back-up fuel in DFC power plants for homeland security and other secure power applications where continuous power is critical.



Propane, a readily available and transportable fuel that can easily be stored on-site, can be advantageously used as a primary fuel at sites without access to natural gas. Coupled with the quiet, non-polluting and high efficiency attributes of the DFC fuel cell power plant, operating on propane is an ideal power solution for remote sites, and particularly in environmentally sensitive areas such as islands and national parks. The demonstrated ability to transfer from the primary fuel to propane as a back-up fuel, while maintaining full power output in either grid connected or grid independent power operation, extends the utility of the DFC-on-propane to secure power applications such as military installations, data centers, and hospitals. The notion of dual fuel operation is part of the rapid evolution of fuel cells as a replacement for conventional electric power where high efficiency, increased reliability, reduced harmful emissions, and lower noise levels are key requirements. This technology will continue to evolve and serve the military and commercial markets demanding secure and reliable power.

## References

- American Society for Testing and Materials (ASTM). 01 April 2005. ASTM D 1835, *Standard Specification for Liquefied Petroleum (LP) Gases*.
- American Society of Mechanical Engineers (ASME). 29 November 2002. *Fuel Cell Power Systems, Performance Test Codes*, ASME PTC 50-2002.
- Appleby, John A. December 1991. "Fuel Cells for Tactical Battlefield Power," *Aerospace and Electronics Systems*, IEEE, vol. 6, No. 12, pp 49-55.
- Brdar D., and M. Farooque. Oct/Nov 2005. "Materials Shape Up for MCFC Success," *The Fuel Cell Review*, vol. 2, No. 5.
- Brdar D., C. Bentley, M. Farooque, P. Oei, and T. Rauseo. 16 November 2006. "Stationary Fuel Cell Power Plants Status," *2006 Fuel Cell Seminar*, Abstract 84.
- Brown, L. F. 2001. "A Comparative Study of Fuels for on-Board Hydrogen Production for Fuel-Cell Powered Automobiles," *International Journal of Hydrogen Energy*, vol. 26, pp 381-397.
- Concurrent Technologies Corp. 02 December 2005. *FuelCell Energy DFC300A Fuel Cell Combined Heat and Power Test Report*. Submitted to the U.S. Army Engineer Research and Development Center.
- Department of the Army (DA). August 2006. *Army Energy and Water Campaign Plan for Installations*, p 52, accessible through URL:  
[http://army-energy.hqda.pentagon.mil/docs/campaign\\_plan\\_01\\_08\\_06.pdf](http://army-energy.hqda.pentagon.mil/docs/campaign_plan_01_08_06.pdf)
- Farooque M, and H. C. Maru. 2006. "Carbonate Fuel Cells: Milliwatts to Megawatts," *Journal of Power Sources*, No. 160, pp 827-834.
- FuelCell Energy, Inc. March 2005. Final Technical Progress Report, "Molten Carbonate Fuel Cell Product Design Improvement," submitted to U.S. Department of Energy National Energy Technology Laboratory.
- King County and CH2MHill. April 2007. *King County Fuel Cell Demonstration Project*, Final report prepared for the U.S. Environmental Protection Agency (USEPA).
- Peltier, R. 2006. "1-MW Fuel Cell Cogeneration Project, Sierra Nevada Brewing Co., Chico, California," *Power*, p 150.
- Science Applications International Corporation (SAIC). October 2000. *Fuel Cell Handbook*, 5<sup>th</sup> ed., Prepared by EG&G, Parsons Inc., SAIC, for the U.S. Department of Energy (DOE)/National Energy Technology Laboratory (NETL).
- Semelsberger, Troy A., et al. August 2004. "Equilibrium Products from Autothermal Processes for Generating Hydrogen-Rich Fuel-Cell Feeds," *International Journal of Hydrogen Energy*, vol. 29, No. 10, pp 1047-1064.
- Varbanov, Petar, et al. November 2006. "Power Cycle Integration and Efficiency Increase of Molten Carbonate Fuel Cell Systems," *Journal of Fuel Cell Science and Technology*, vol. 3, No. 4, pp 375-383.

## Acronyms and Abbreviations

<u>Term</u>	<u>Spellout</u>
AC	Alternating Current
ASME	American Society of Mechanical Engineers
Btu	British Thermal Unit
°C	Degrees Centigrade
CCB	Critical Customer Bus
CERL	Construction Engineering Research Laboratory
CH <sub>4</sub>	Methane
CO	Carbon Monoxide
CO <sub>2</sub>	Carbon Dioxide
CTC	Concurrent Technologies Corporation
DFC®	Direct Fuel Cell®
DoD	Department of Defense
e-	Electrons
ERDC	Engineer Research and Development Center
°F	Degrees Fahrenheit
FCE	FuelCell Energy, Inc.
FCTec	Fuel Cell Test and Evaluation Center
GC	Gas Chromatograph
gph	gallons per hour
H <sub>2</sub>	hydrogen
H <sub>2</sub> O	water
kW	kilowatt
LHV	Lower Heating Value
MCFC	Molten Carbonate Fuel Cell
MWh	megawatt-hours
NIST	National Institute of Standards and Technology
O <sub>2</sub>	oxygen
PAFC	Phosphoric Acid Fuel Cell
PEMFC	Polymer Electrolyte Membrane Fuel Cell
PDS	Propane Desulfurization System
ppm	parts per million
psig	pounds per square inch gauge

# REPORT DOCUMENTATION PAGE

Form Approved  
OMB No. 0704-0188

Public reporting burden for this collection of information is estimated to average 1 hour per response, including the time for reviewing instructions, searching existing data sources, gathering and maintaining the data needed, and completing and reviewing this collection of information. Send comments regarding this burden estimate or any other aspect of this collection of information, including suggestions for reducing this burden to Department of Defense, Washington Headquarters Services, Directorate for Information Operations and Reports (0704-0188), 1215 Jefferson Davis Highway, Suite 1204, Arlington, VA 22202-4302. Respondents should be aware that notwithstanding any other provision of law, no person shall be subject to any penalty for failing to comply with a collection of information if it does not display a currently valid OMB control number. PLEASE DO NOT RETURN YOUR FORM TO THE ABOVE ADDRESS.

<b>1. REPORT DATE (DD-MM-YYYY)</b> 30-10-2007		<b>2. REPORT TYPE</b> Final		<b>3. DATES COVERED (From - To)</b>	
<b>4. TITLE AND SUBTITLE</b> Molten Carbonate Fuel Cell Operation with Dual Fuel Flexibility				<b>5a. CONTRACT NUMBER</b>	
				<b>5b. GRANT NUMBER</b>	
				<b>5c. PROGRAM ELEMENT NUMBER</b>	
<b>6. AUTHOR(S)</b> Joseph Daly, George Steinfeld, David K. Moyer, and Franklin H. Holcomb				<b>5d. PROJECT NUMBER</b>	
				<b>5e. TASK NUMBER</b>	
				<b>5f. WORK UNIT NUMBER</b>	
<b>7. PERFORMING ORGANIZATION NAME(S) AND ADDRESS(ES)</b> U.S. Army Engineer Research and Development Center (ERDC) Construction Engineering Research Laboratory (CERL) PO Box 9005, Champaign, IL 61826-9005				<b>8. PERFORMING ORGANIZATION REPORT NUMBER</b>  ERDC/CERL TR-07-43	
<b>9. SPONSORING / MONITORING AGENCY NAME(S) AND ADDRESS(ES)</b> Office of the Director, Defense, Research, and Engineering (ODDR&E) 1777 N. Kent, Suite 9030 Rosslyn, VA 22209				<b>10. SPONSOR/MONITOR'S ACRONYM(S)</b>  ODDR&E	
				<b>11. SPONSOR/MONITOR'S REPORT NUMBER(S)</b>	
<b>12. DISTRIBUTION / AVAILABILITY STATEMENT</b> Approved for public release; distribution is unlimited.					
<b>13. SUPPLEMENTARY NOTES</b>					
<b>14. ABSTRACT</b> <p>The ability to operate highly-efficient, pollution-free, distributed-generation power plants on either natural gas or HD-5 grade propane is of interest to the U.S. Army and the U.S. Department of Homeland Security as secure power for critical power operations. To address this interest, Concurrent Technologies Corporation (CTC) teamed with FuelCell Energy (FCE) to test an internally reforming 250 kW carbonate direct fuel cell using HD-5 propane. This fuel cell power plant, originally designed to operate on pipeline natural gas or digester gas, was modified for dual fuel operation (natural gas and propane). Fuel cell operation using HD-5 propane was demonstrated for over 3,900 hrs and achieved high electrical efficiency (45.7 to 47.1 percent lower heating value [LHV]) over a broad range of power outputs. In addition, instantaneous and on-load fuel switching from natural gas to propane and back was demonstrated without loss of power. This dual fuel power plant operated efficiently on either fuel and can provide the U.S. Army and other power users with a viable technology solution for critical power operations.</p>					
<b>15. SUBJECT TERMS</b> fuel cells                      propane power generation            utilities					
<b>16. SECURITY CLASSIFICATION OF:</b>			<b>17. LIMITATION OF ABSTRACT</b>	<b>18. NUMBER OF PAGES</b>	<b>19a. NAME OF RESPONSIBLE PERSON</b>
<b>a. REPORT</b> Unclassified	<b>b. ABSTRACT</b> Unclassified	<b>c. THIS PAGE</b> Unclassified			<b>19b. TELEPHONE NUMBER (include area code)</b>