

COLLABORATIVE VEHICLES IN FUTURE NAVAL MISSIONS, OBSTACLE DETECTION AND AVOIDANCE

Anthony J Healey
Distinguished Professor
Department of Mechanical and Astronautical Engineering
Naval Postgraduate School
Monterey, CA 93943
healey@nps.edu

Douglas P. Horner
Assistant Research Professor
Department of Mechanical and Astronautical Engineering
Naval Postgraduate School
Monterey, CA 93943
dphorner@nps.edu

ABSTRACT

In this Keynote paper, the authors attempt to provide some overarching view of the needs for vehicle collaboration based on future Naval missions. Collaboration between differing types of autonomous vehicle, surface, ground, aerial and underwater will be required to achieve the utility in operations promised by the concepts to date. At NPS we are also working on obstacle detection and avoidance for small AUVs which is a subject also discussed here. Recent advances in the development of low cost forward looking sonar arrays, has enabled the class of small Unmanned Underwater Vehicles to exhibit a capability for obstacle detection and avoidance. At NPS, the authors have studied the problems involved both using simulation models and through in water experimentation and validation. This paper reviews the concept of obstacle detection using a small “Blazed Array” forward looking sonar (FLS), illustrates the techniques used to analyze images obtained from an FLS, and perform threat assessment. The implementation of an avoidance controller in the NPS ARIES vehicle will be described along with a discussion of methodologies for vertical plane avoidance maneuvering. One particular strategy has been implemented and tested in the Underwater Test Range at Keyport, WA. The experiments performed will be discussed and analyzed. We show that one of the problems encountered arises when parts of the seabed are occluded from the sonar view. This leads to the notion of an uncertainty map being obtained from the FLS and used to drive the vertical response of the vehicle. Occlusion maps are built from the FLS data, and used to provide added maneuvering commands based on uncertainty. Vehicle response lags, normally a consideration with normal avoidance commands are mitigated using the FLS capability to look ahead.

1. INTRODUCTION AND BACKGROUND FUTURE NAVAL MISSIONS

The US Navy vision for the next several years is embodied in the Sea Power 21 notion with its component pieces; *Sea Shield*, *Sea Basing*, and *Sea Strike*. These three elements form an overarching strategy that is connected through the concept of *ForceNet*. *ForceNet* is the glue that makes the three elements cohesive. Enablers to *Force Net* include *Sea Trial*, which for example, is aimed the problem of concept development through coordinated continued experimentation. This is critical as new technologies arise quickly and it becomes important to show warfighters

what technologies can assist and how they can be used tactically.



Figure 1 Taken from (Clarke, 2002)

Report Documentation Page

Form Approved
OMB No. 0704-0188

Public reporting burden for the collection of information is estimated to average 1 hour per response, including the time for reviewing instructions, searching existing data sources, gathering and maintaining the data needed, and completing and reviewing the collection of information. Send comments regarding this burden estimate or any other aspect of this collection of information, including suggestions for reducing this burden, to Washington Headquarters Services, Directorate for Information Operations and Reports, 1215 Jefferson Davis Highway, Suite 1204, Arlington VA 22202-4302. Respondents should be aware that notwithstanding any other provision of law, no person shall be subject to a penalty for failing to comply with a collection of information if it does not display a currently valid OMB control number.

1. REPORT DATE

SEP 2006

2. REPORT TYPE

3. DATES COVERED

00-00-2006 to 00-00-2006

4. TITLE AND SUBTITLE

Collaborative Vehicles in Future Naval Missions, Obstacle Detection and Avoidance

5a. CONTRACT NUMBER

5b. GRANT NUMBER

5c. PROGRAM ELEMENT NUMBER

6. AUTHOR(S)

5d. PROJECT NUMBER

5e. TASK NUMBER

5f. WORK UNIT NUMBER

7. PERFORMING ORGANIZATION NAME(S) AND ADDRESS(ES)

Naval Postgraduate School, Center for Autonomous Underwater Vehicle Research, Monterey, CA, 93943

8. PERFORMING ORGANIZATION REPORT NUMBER

9. SPONSORING/MONITORING AGENCY NAME(S) AND ADDRESS(ES)

10. SPONSOR/MONITOR'S ACRONYM(S)

11. SPONSOR/MONITOR'S REPORT NUMBER(S)

12. DISTRIBUTION/AVAILABILITY STATEMENT

Approved for public release; distribution unlimited

13. SUPPLEMENTARY NOTES

Proceedings of the IFAC Conference on Modelling and Control of Marine Craft, MCMC, 2006, Lisbon, Portugal, September 20-23, 2006

14. ABSTRACT

In this Keynote paper, the authors attempt to provide some overarching view of the needs for vehicle collaboration based on future Naval missions. Collaboration between differing types of autonomous vehicle, surface, ground, aerial and underwater will be required to achieve the utility in operations promised by the concepts to date. At NPS we are also working on obstacle detection and avoidance for small AUVs which is a subject also discussed here. Recent advances in the development of low cost forward looking sonar arrays, has enabled the class of small Unmanned Underwater Vehicles to exhibit a capability for obstacle detection and avoidance. At NPS, the authors have studied the problems involved both using simulation models and through in water experimentation and validation. This paper reviews the concept of obstacle detection using a small "Blazed Array" forward looking sonar (FLS), illustrates the techniques used to analyze images obtained from an FLS, and perform threat assessment. The implementation of an avoidance controller in the NPS ARIES vehicle will be described along with a discussion of methodologies for vertical plane avoidance maneuvering. One particular strategy has been implemented and tested in the Underwater Test Range at Keyport, WA. The experiments performed will be discussed and analyzed. We show that one of the problems encountered arises when parts of the seabed are occluded from the sonar view. This leads to the notion of an uncertainty map being obtained from the FLS and used to drive the vertical response of the vehicle. Occlusion maps are built from the FLS data, and used to provide added maneuvering commands based on uncertainty. Vehicle response lags, normally a consideration with normal avoidance commands are mitigated using the FLS capability to look ahead.

15. SUBJECT TERMS

16. SECURITY CLASSIFICATION OF:			17. LIMITATION OF ABSTRACT Same as Report (SAR)	18. NUMBER OF PAGES 10	19a. NAME OF RESPONSIBLE PERSON
a. REPORT unclassified	b. ABSTRACT unclassified	c. THIS PAGE unclassified			

Standard Form 298 (Rev. 8-98)
Prescribed by ANSI Std Z39-18

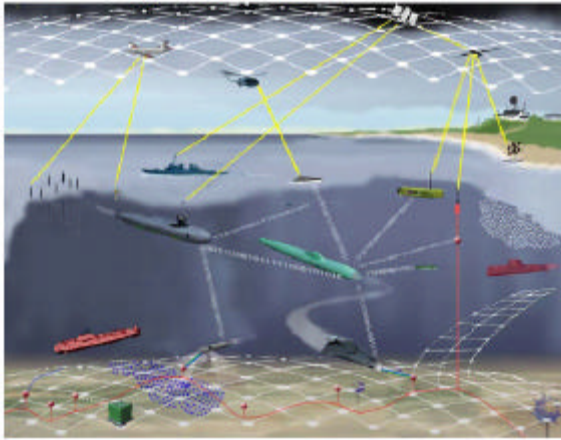

Figure 2 Force Net Concept for Integrated Space, Aerial, Surface and Underwater and Ground Systems.

In a ForceNet operational concept the links between vehicles are both radio and acoustic and are critical to the information flow through the networks. How such systems are utilized by operators remains to be seen, but it involves collaboration between assets.

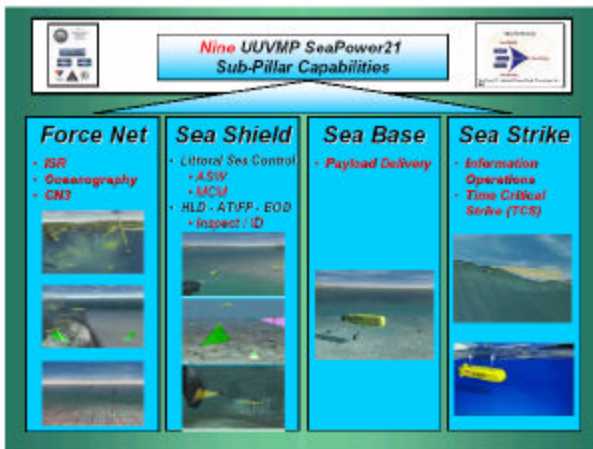

Figure 3 From the UUV Master Plan, US Navy

The UUV Master Plan for the US Navy delineates four areas of important application for future UUVs; Force Net, Sea Shield, Sea Base, and Sea Strike in which typical missions would include,

- a) Intelligence gathering, and Oceanography,
- b) Anti Submarine Warfare and Mine Countermeasures and Inspection
- c) Payload delivery, Persistent Presence,
- d) Information Operations, Targeting and Time Critical Strike.

Class	Diameter (inches)	Displacement (lbs.)	Endurance High Hotel Load (hours)	Endurance Low Hotel Load (hours)	Payload (ft ³)
Man-Portable	3 - 9	< 100	< 10	10 - 20	< 0.25
LWV	12.75	~ 500	10 - 20	20 - 40	1 - 3
HwV	21	< 3,000	20 - 50	40 - 80	4 - 6
Large	> 36	~ 20,000	100 - 500	>> 400	15 - 30 + External Stores

Figure 4 Classes of UUV as foreseen in the UUV Master Plan.

Four classes of UUV are foreseen to meet the needs of the strategy ranging in size / endurance from the Man Portable with Diameter ranging from 3-9 inches (8-22) centimeters, through the Light Weight at diameter of 12.75 inches (32 cm.), the Heavy Weight 21 inches Diameter, (54cm.), to the Large Vehicle greater than 1 meter Diameter. Each vehicle class has a different role based on increasing endurance and range.

Mission and Task	Autonomous Vehicle Applicability			
	UAV	USV	UUV	UGV
Providing ground surveillance and targeting	•			
For nearshore fire support	•			
For support of Ship-to-Objective Maneuver	•	•	•	•
For deep strike	•			
For suppression of enemy air defenses	•			
For looking over the hill	•			
For urban warfare	•			•
Countering mines in the sea	•	•	•	
Countering mines in surf on beach	•			•
Countering land mines	•			•
Countering diesel submarines	•	•	•	
Countering surface craft	•	•		
Countering antiship cruise missiles	•	•		
Detecting chemical, biological, radiological attack	•	•		•
Providing maritime surveillance	•			
Environmental monitoring	•	•	•	•

Figure 5 Missions and Tasks for Differing Vehicle Types.

Missions and Tasks for combined Systems of Differing types of vehicle are illustrated in Figure 5. Clearly the combination of UAVs, UUVs, USVs and UGVs provide a wide range of capability, especially when used together to achieve greater range of communication and or vision for queuing.

2. MULTI VEHICLE COOPERATION

The particular utility of vehicle collaboration lies in the capabilities being different among surface, submarine and aerial assets and ground based stations. For example, an aerial vehicle, being an 'eye in the sky', may be used to key ground vehicles that have limited field of view, or surface vehicles whose field of view is blocked as in

some cases in riverine operations. An underwater vehicle has a unique capability to remain covert and detect objects in the water column that are unseen from above. It follows that combination of different modalities of vehicle provide great benefit.

Collaboration requires communication. Thus operations with links that are uncertain, drop in and out, requires greater levels of autonomy than that required for single vehicle operation with a good up and down links for control and video transmission.

NPS has been involved in development of high speed C^2 links among submarine, surface and aerial vehicles (TNT exercises), and have demonstrated video up and down links through aircraft. Data rate and range are linked as shown in Figure 6 taken from (Horner, et. al., 2005).

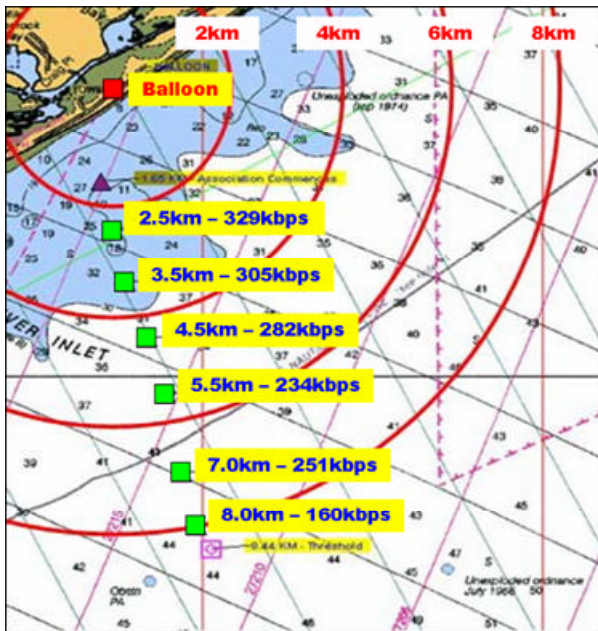

Figure 6, Data Rate for 802.11 Links based on Range to Sea. Experiments at Camp Lejeune 2004 More Details in (Horner, et. al., 2005)

Distributed Autonomous Systems (DAS) provide advantages explained in Figure 5 to achieve greater utility than a system of multiple homogeneous vehicles as described in (ibid, 2005) for application to Maritime Domain Awareness. In particular, using aerial vehicles to provide situational awareness information to ground and surface vehicles is paramount.

3. OBSTACLE DETECTION AND AVOIDANCE FOR AUVs

Obstacle detection and avoidance is a subject well studied in robotics, and covers wide areas of application. For indoor robots, it is common to use small acoustic sensors to detect walls / doorways, and other features generating an appropriate avoidance response as needed. Examples of such work include (Khatib, 1986, Borenson, 1991, Moite, 2000). A more substantial problem exists for field robotics, at the heart of which is the problem of finding suitable sensors that will reliably detect an obstacle amongst clutter. DARPA grand challenge vehicles, for example, combine laser based systems, video systems, radio based systems, but for underwater, we rely on sonar systems. Underwater video is attractive in high visibility areas, but these are hard to find in many littoral water environments. While side scan sonars have been used for many years in the detection of manlike objects, they are not suitable for detection of objects in the path of an underwater vehicle as no advance notice is provided. Arranged as a Forward Look Sonar (FLS), arrays have recently been developed that may be mounted for detection in the vertical plane, or by other arrangements, in the horizontal plane. The term “Blazed Array” refers to its use of differing frequencies/wavelengths of acoustic energy being deflected into different beams, thus such an array emits energy spread over a fan of beams, returns from which form a triangular shaped image plane. In what follows we describe the use of potial functions for the generation of paths that a vehicle would follow where the inclusion of a detected obstacle provide smooth deviation to the path for avoidance. In our work, we have distinguished between horizontal and vertical planes since in the underwater realm, vehicle pitch is limited and the equations of motion decouple well.

In spite of the desire to effect a common methodology for avoiding horizontally and vertically the nature of underwater vehicles allows well for the division of problems into horizontal and vertical domains and separate methods for each. Thus, it is appropriate to generate an integrated, guidance, path planning, and avoidance behavior along the lines described by (Kaminer et al., 1998). The Path Generation evolves from a total Potential Field consideration in which paths are generated by its continual minimization, subject to a set of constraints on

vehicle mobility. In our case, Gaussian avoidance functions are used to generate smooth differentiable paths, with variances adjusted as a parameter linked to turning capability of the vehicle. As obstacles are revealed in the FLS image, Gaussian functions are added to the total field, generating new paths for the vehicle to track. In the vertical plane, if there is room above the obstacle, a Gaussian function of appropriate height is added to the altitude command, directing a pitch change input to a pitch control autopilot and steering commands to the steering autopilots.. These behaviors have been studied before and presented by (Fodrea and Healey, 2004), and for the vertical plane behaviors by (Hemminger, 2005) and (Furakawa, 2006).

This behavior in the vertical plane has also been studied in detail for the REMUS vehicle by Furakawa, 2006.

4. PATH GENERATION

Given a total Global Potential Field,

$$V(X,Y,Z,\mathbf{a}) > 0,$$

composed of track following potentials and obstacle avoidance potentials, with parameters, \mathbf{a} , set according to vehicle motion constraints of curvature, the vehicle desired path in a global Navigational Frame, X,Y,Z, evolves according to

$$\dot{\mathbf{x}} = f(u), \quad \mathbf{x} = [X, Y, Z]^T$$

$$u = [\mathbf{y}_{com}, \mathbf{q}_{com}]$$

so that the projection

$$\nabla V \cdot \mathbf{f} < 0 \quad \forall t > 0$$

In developing potential functions for path tracking and obstacle avoidance, it is assumed that functions will be used such that there is a unique local minimum in the region of interest, and that the gradient, $\|\nabla V\| \neq 0$ anywhere.

The path generation model is

$$\dot{X} = U \cos(\mathbf{y}_{com})$$

$$\dot{Y} = U \sin(\mathbf{y}_{com})$$

$$\dot{Z} = -U \mathbf{q}_{com}$$

Where, U is the forward speed of the vehicle.

The reduction of the potential, V , is accomplished using

$$f = - \begin{bmatrix} \mathbf{h}_1 & 0 & 0 \\ 0 & \mathbf{h}_2 & 0 \\ 0 & 0 & \mathbf{h}_3 \end{bmatrix} \nabla V$$

From which

$$\dot{V} = -\nabla V^T \begin{bmatrix} \mathbf{h}_1 & 0 & 0 \\ 0 & \mathbf{h}_2 & 0 \\ 0 & 0 & \mathbf{h}_3 \end{bmatrix} \nabla V < 0 \quad \forall t > 0$$

and the \mathbf{h}_i are disposable positive parameters to give some degree of adjustment in the resulting path.

The path is generated as the evolution of $[X(t), Y(t), Z(t)]$ subject to initial conditions taken from the vehicle's current position at $t = t_0$.

Decoupling the path generation into horizontal and vertical planes, we get

Horizontal Path Generation:

$$\begin{bmatrix} U \cos(\mathbf{y}_{com}) \\ U \sin(\mathbf{y}_{com}) \end{bmatrix} = - \begin{bmatrix} \mathbf{h}_1 & 0 \\ 0 & \mathbf{h}_2 \end{bmatrix} \begin{bmatrix} V'_X \\ V'_Y \end{bmatrix}$$

Leading to a solution for the heading command.

Using, $\mathbf{h} = \frac{\mathbf{h}_2}{\mathbf{h}_1}$,

$$\mathbf{y}_{com} = a \tan(-V'_Y, -\mathbf{h} V'_X)$$

Vertical Plane

Considering the vertical plane separately, the solution for the path pitch angle becomes,

$$-U \mathbf{q}_{com} = V'_Z$$

Potential Function Selection

A UUV mission will be defined in terms of a series of waypoints with nominally straight line segments, and conditions for transition from one to the next. To follow a track defined by 2 waypoints, $i+1$ and i , we define a track heading,

$$\mathbf{y}_{track} = a \tan((Y_{i+1} - Y_i), (X_{i+1} - X_i))$$

and define along track and cross track potentials, V_a and V_c

$$V_a = (1 - bs); \quad V_c = k_1 e^2; V_z = k_2 z^2$$

where s is the along track distance, the cross track error is, e , and z , the vertical deviation from the nominal altitude /depth command. These values are determined using a Serret-Frenet frame located on the path to be followed at a point of closest to the vehicle. This work follows that of (Kaminer, Pascoal, Hallberg and Silvestre, 1998)

The track following gradients of potentials are incorporated into the total Global Potential Field gradient by the 3*3 rotation matrix, $T(\mathbf{y}_{track})$,

$$\mathbf{V}'_{track} = T(\mathbf{y}_{track}) [V'_a; V'_c; V'_z]$$

These potentials alone will drive the vehicle through a set of way points provided suitable logic is included for track termination (see Healey, 2006).

Avoidance when objects are detected at locations, $[x_j, y_j, z_j]$, is accomplished through addition of the Gaussian potentials, V_{oj}

$$V_{oj} = \sum_{i=1}^N V_i \exp[-((X - x_i)^2 + (Y - y_i)^2) / 2s_i^2]$$

for the horizontal plane avoidance and

$$V_{oj} = \sum_{i=1}^N V_i \exp[-((X - x_i)^2 + (Z - z_{oi})^2) / 2s_i^2]$$

for vertical plane avoidance and z_o is a depth for the object to be avoided. Gradients of the avoidance potentials are added to the track following gradients for the total potential field gradient computation.

The total gradient in the X and Y and Z directions are then

$$V'_X = \sum V'_{ojX} + V'_{trackX}$$

$$V'_Y = \sum V'_{ojY} + V'_{trackY}$$

$$V'_Z = \sum V'_{ojZ} + V'_{trackZ}$$

Path Following

Path following with potential paths as generated, allows an important additional feature in that the path may be evaluated at a distance M ahead of the vehicle on the path thereby reducing vehicle

special response lags. Figure 7 illustrates a horizontal plane avoidance with a 20 mtere standard deviation used in the Gaussian functions.

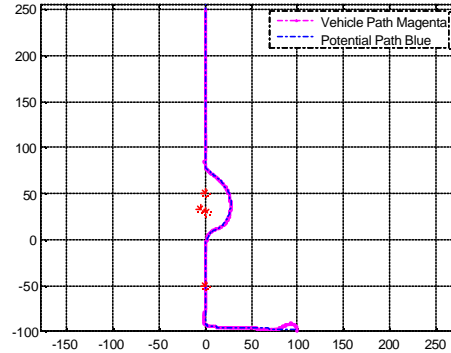

Figure 7 Horizontal Plane Obstacle Avoidance Path and Vehicle response with a 50 meter look ahead Distance .

Solutions for the horizontal plane path have been generated and ARIES steering response are shown in Figure 7, with three objects around $X=50$ meters to be avoided horizontally. The object at $X=-50$ is to avoided vertically as shown in Figure 8.

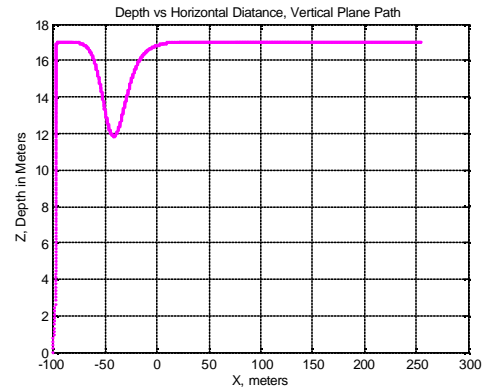

Figure 8 Vertical Plane (Depth, Z vs Horizontal Distance, X) Path generated from Potential Function Guidance Law. Avoiding with a 5 meter Rise Around $X=50$, Running at 17 Meters Depth, 3 meters Above Bottom.

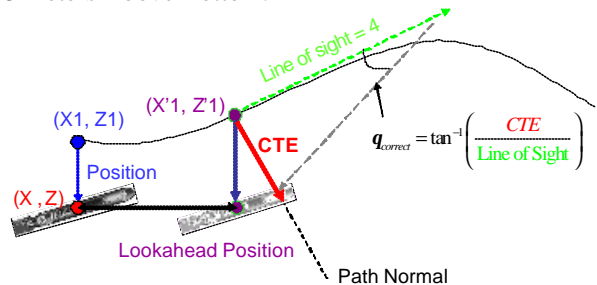

Figure 9, Look Ahead position for Pitch or Heading Command Computation in Following Potential Paths (Furakawa,2006).

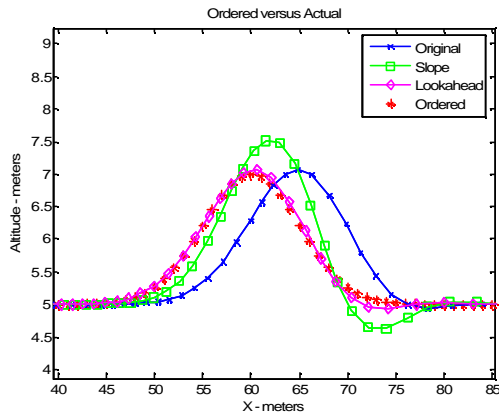

Figure 10, REMUS Vehicle Obstacle Avoidance Responses Responses Using Look ahead from Gaussian Paths for Obstacle Avoidance to Eliminate Spatial Response Lags, Altitude vs Horizontal Distance, (Furakawa, 2006).

5. BLAZED ARRAY FLS, OBJECT DETECTION

We have been experimenting with a Blazed Array Forward looking Sonar (FLS). The FLS can be configured either in the horizontal or vertical planes. In the vertical plane, it is suitable for detecting sudden rises in sea bottoms that would otherwise cause the vehicle to ground while performing mine hinting missions close to the seabed.

The obstacle detection part is a critical part of the control system and first begins with image gathering and analysis.

Figure 11 illustrates the nominal projection of sound from the arrays with the vertical mounting. Using a normal to the vertical surface of the stave as a reference, the high frequencies emanate outward at approximately 22.5 degrees and the low frequencies at 45 degrees. Each stave also has approximately 12 degrees of horizontal aperture as illustrated in Figure 10.

Figure 12 is an example of two images from Blazed Array mounted on the NPS ARIES. The sonar transducer attached to the ARIES AUV is located at the top left corner of each image. The strong linear return in each of the images is typical of an ocean floor without obstacles. The volume above the ocean floor is the ensonified

portion of the water column and is bounded by the upper and lower frequency of each sonar stave.

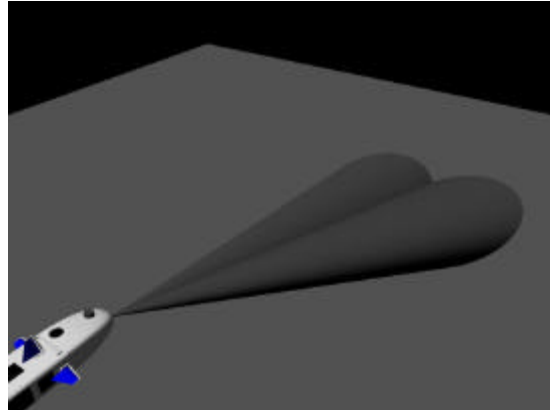

Figure 11. Projection of the Blazed Array Sonar on the Seabed Vertical Configuration

For our application, the sonar is set to a medium low resolution which results in an image size 491x 198 pixels or an effective range of approximately 80 meters. This resolution permits a 1 Hz sonar update rate which is reasonable for obstacle detection for avoidance..

Relating to Figure 12, d_1 and d_2 represent the distance calculations from the nearest and farthest sonar beams (respectively) as they reflect off a featureless ocean floor. Θ_T is the total angle measurement taking into account the sonar mounting angle (Θ_a) and the pitch of ARIES at time t , ($\Theta(t)$).

$$d_1 = h \tan(\Theta_T)$$

$$d_2 = h \tan(\Theta_T + 22.5)$$

$$\Theta_T = 45 + \Theta_a + \Theta(t)$$

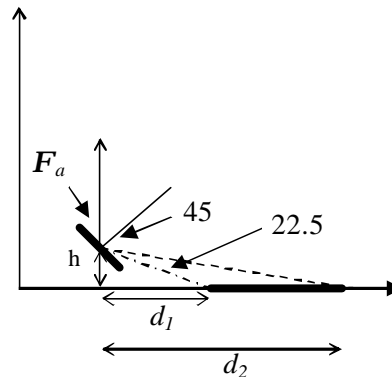

Figure 12 Geometry of Image and Seabottom Ensonification

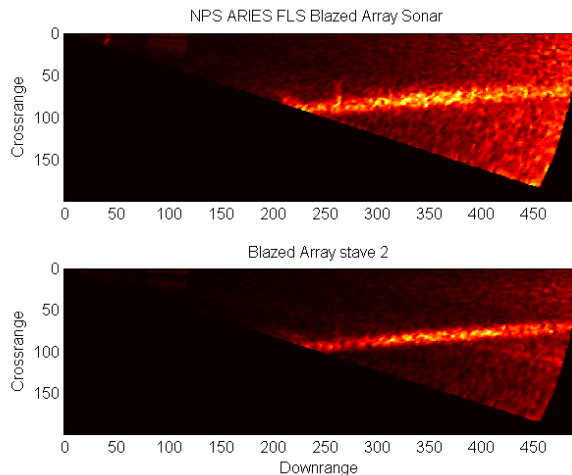

Figure 13. Vertical Configuration for Arrays Showing Strong Returns from Seabed.

6. SONAR IMAGE PROCESSING

The goal is to detect obstacles that represent a threat to the AUV. In general, the goals of the image processing are as follows:

1. Identify the ocean floor.
2. Establish a Region Of Interest (ROI) search space
3. Search the ROI for obstacles
4. Identify and track obstacles
5. Provide measurements to the autopilot controller
 - a. Distance of obstacle from ARIES
 - b. Height of obstacle
 - c. Centroid of obstacle

The first step is gathering statistics on each image to determine a threshold value. The threshold value is used to create a binary image where values less than the threshold are set equal to zero and values equal to or above the threshold are set to one. The next step is to erode the images. Erosion of the binary image sets each pixel to the minimum of a 3x3 region where the pixel is the center point of the region. This is done to give a finer definition to the structural returns from the sonar.

An important step in the process is the use of a transform to identify the pitch of the ocean floor. It is used to isolate linear features within the sonar image. As seen in Figure (13), a typical sonar image with arrays in the vertical orientation displays a strong linear feature corresponding to the ocean floor. The transform starts from a

reference point and searches through the image for strong evidence of lines.

The result of the transform is a series of candidate solutions. Selection of the best candidate line is determined by three factors: First a four-state Kalman Filter was used where the measurement model includes: Vehicle pitch, pitch rate and the two rotation angles determined by the transforms (one for each image). The filter produces an estimate for the rotation angle necessary to produce a flat ocean floor slope. This estimate together with an added margin of error is used to deselect candidate lines. Second, the line segment length is used as a criterion for selection where longer lines are considered stronger candidates. The final criterion is the location of the line segment in the image. Stronger candidate lines are located close to the predictive near and far boundaries of the sonar projection on the ocean floor given a vehicle altitude. The combined effect of the selection process is to serve as a spike rejector for erroneous transform results.

After the proper slope of the ocean floor has been selected a Region Of Interest (ROI) was identified relative to the ocean floor. Position of the ROI is dependent on the altitude of the AUV. Using values for d_2 , one can project the ROI search space based on the current altitude; this defined the near and far ROI boundaries. The lower ROI boundary is determined by the vehicle altitude and the upper ROI boundary is defined by the upper image boundary. This ROI is well-suited for vertical avoidance and obstacle searches proud of the ocean floor, different ROIs are required for volume and horizontal searches.

The ROI search space is where obstacles are detected and tracked. Detection is accomplished by searching for contours in the binary image and calculating the interior area. If the object is large enough it is registered as an obstacle. Obstacles are tracked using a second Kalman Filter where if the relative speed of the obstacle matches closely to ARIES forward velocity, the trajectory is on a collision path and the obstacle has been identified greater than a threshold level of times, a network message is sent to the autopilot controller.

While the two arrays are mounted in a vertical configuration, there is an approximately 12 degree horizontal component to the images. The arrays are mounted so that the horizontal components have a small degree of overlap. This can be helpful in determining when ARIES is on

a collision course. If the obstacle appears equally strong in each image and the vehicle is traveling in a straight path, the AUV is on a collision course. Conversely, the appearance of an obstacle in one image and not in the other indicates that the vehicle can make small horizontal corrections to the opposite side. This information can also be used for tracking vehicle navigation by applying optimal flow techniques to image analysis.

7. HARDWARE AND SOFTWARE ARCHITECTURE

A principle feature of the ARIES AUV is its flexibility for housing new hardware and software for testing new methodologies in underwater robotics. There are three components of the Blazed Array sonar: The arrays, the electronics and a PC-104 computer for image storage and processing. The original bow design was modified to mount the arrays. To maintain hydrodynamic efficiency, flexible polyurethane nose was constructed to house the arrays. This minimizes signal attenuation and provides a degree of protection. The construction of the nose permits the arrays to be oriented either in the horizontal or vertical position.

The power and control signals are passed through a water tight bulkhead and attached to the electronics. From there, images are saved and processed using a Windows based PC-104 computer. A graphical depiction is given in Figure 13.

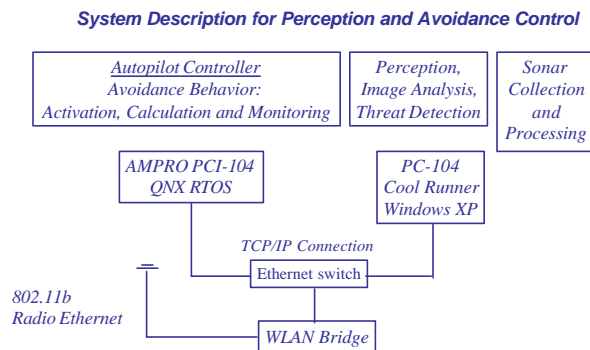

Figure 14 .Hardware / Software Diagram for FLS Obstacle Detection and Avoidance. Mounted in ARIES June 2005

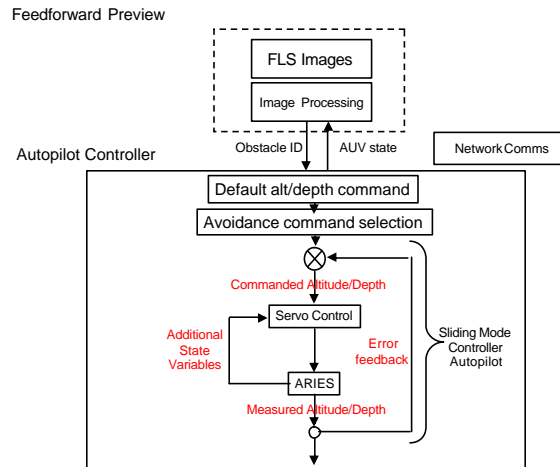

Figure 15. Feed Forward Avoidance Control Diagram, ARIES 2005

8. DETECTION AND AVOIDANCE EXPERIMENTAL RESULTS

Initial experiments and demonstrations were accomplished during the Office of Naval Research (ONR) AUV FEST 2005 at Naval Undersea Warfare Center, Keyport, WA, June 06-16, 2005. The objective was to demonstrate avoidance in the vertical plane by navigating over the top of a designated obstacle proud of the ocean floor. The obstacle was a sunken barge, which at its peak is 6 meters off the ocean floor and approximately 15 meters wide.

Figure (16) shows the results of an ARIES avoidance run. From the top moving downward, the graph includes the total water depth, vehicle altitude, vehicle depth and pitch and the results of the image processing to determine the image rotation necessary to project a flat ocean floor. The X axis is vehicle state information taken at each sonar image and the Y axis represent units of degrees and meters as appropriate. The difference between the vehicle pitch and image rotations is the mounting angle of the sonar staves (approximately -6 degrees). The avoidance behavior is highlighted in the box area of Figure (16) between images 250 and 300. The additive (and subtractive) altitude command is the result of sonar image processing identifying and passing the position and height of the obstacle to the vehicle controller. The autopilot controller avoids the obstacle using the Gaussian path additive to the original fixed altitude navigation run. The remaining altitude adjustments are the results of

GPS (popups) navigation updates and mission completion. Figure (17) shows a sonar image from both staves of the detection of the underwater barge.

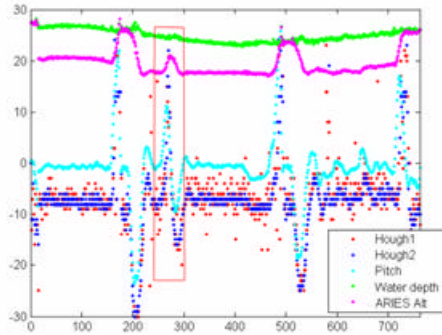

Figure 16. ARIES avoidance results illustrating a 4 meter high Gaussian rise over the obstacle.

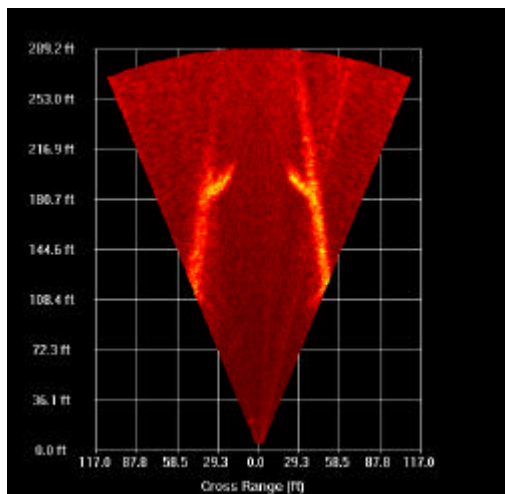

Figure 17. Blazed Array FLS Images of underwater barge Taken at Keyport, WA June 2005 showing right and left side arrays detecting strong bottom returns and a proud object 6m high

9. CONCLUSIONS

In this paper, we have outlined future mission scenarios that require the use of different vehicle assets and types in an overarching integrated system concept. Inter vehicle are paramount to the utility of these concepts. We also have described the use of potential functions for path generation, and obstacle avoidance guidance for

underwater vehicles, and some experimental results are shown illustrating the reality and utility of these algorithms using a blazed array forward looking sonar.

10. ACKNOWLEDGEMENTS

The Authors wish to acknowledge the financial support of ONR through Dr. Tom Swean under contract No N0001406WR20057.

11. REFERENCES

BlueView Technologies Inc.

<http://www.blueviewtech.com>

Borenstein, J. and Koren, Y., "The Vector Field Histogram-Fast Obstacle Avoidance for Mobile Robots", *IEEE Journal of Robotics and Automation* Vol 7, No 3, Jun 1991, pp. 278-288.

Clarke, V., 2002, *Sea Power 21*,

<http://www.chinfo.navy.mil/navpalib/cno/proceedings.html>

Fodrea, L., R., Healey, A. J., "Obstacle Avoidance Considerations for the REMUS Autonomous Underwater Vehicle", *Proceedings of the ASME OMAE Conference*, 2003, Cancun, Mexico, June 2003

Furakawa, T., "Reactive Obstacle Avoidance For The Remus Autonomous Underwater Vehicle Utilizing A Forward Looking Sonar", *MSME Thesis, NPS, Department of Mechanical and Astronautical Engineering, Naval Postgraduate School, Monterey Calif. June, 2006*

Healey, A. J., Chapter 3 Guidance Laws, Obstacle Avoidance, Artificial Potential Functions. *Advances in Unmanned Marine Vehicles Ed. Roberts and Sutton, IEE Control Series 69, 2006*

Healey, A. J., "Obstacle Avoidance While Bottom Following for the REMUS Autonomous Underwater Vehicle", *Proceedings of the IFAC IAV Conference*, Lisbon, Portugal, July 2004

Hemming, D L., "Vertical Plane Obstacle Avoidance and Control of the REMUS AUV Using Forward Look Sonar", *MSME Thesis Naval Postgraduate School, Monterey, Calif., June, 2005*

Horner, D. P., Healey, A. J., Kragelund, S. P.
“AUV Experiments in Obstacle Avoidance”,
Proceedings of IEEE Oceans, September 2005

Kaminer, I.I, Pascoal, A. M., Halberg, E.,
Silvestre, C.,“ Trajectory Tracking for
Autonomous Vehicles: An Integrated Approach
to Guidance and Control” *Journal of Guidance
Dynamics and Control*, Vol. 21, No. 1, 1998

Kamon, I. And Rivlin, E., “Sensory-based motion
planning with global proofs”, *IEEE Transaction
on Robotics and Automation*, Vol 13, no. 6, 1997.

Khatib, O., “ Real Time Obstacle Avoidance for
Manipulators and Mobile Robots”, *International
Journal of Robotics Research*, v 5, n 1, 1986, pp.
90-98.

Moitie, R. and Seube, N., “Guidance Algorithms
for UUVs Obstacle Avoidance Systems”,
OCEANS 2000, Brest, France