

# HUMAN ENGINEERING DESIGN DATA DIGEST



HUMAN FACTORS STANDARDIZATION SUBTAG

DEPARTMENT OF DEFENSE  
HUMAN FACTORS ENGINEERING  
TECHNICAL ADVISORY GROUP

## Report Documentation Page

*Form Approved  
OMB No. 0704-0188*

Public reporting burden for the collection of information is estimated to average 1 hour per response, including the time for reviewing instructions, searching existing data sources, gathering and maintaining the data needed, and completing and reviewing the collection of information. Send comments regarding this burden estimate or any other aspect of this collection of information, including suggestions for reducing this burden, to Washington Headquarters Services, Directorate for Information Operations and Reports, 1215 Jefferson Davis Highway, Suite 1204, Arlington VA 22202-4302. Respondents should be aware that notwithstanding any other provision of law, no person shall be subject to a penalty for failing to comply with a collection of information if it does not display a currently valid OMB control number.

1. REPORT DATE <b>APR 2000</b>	2. REPORT TYPE <b>N/A</b>	3. DATES COVERED <b>-</b>	
4. TITLE AND SUBTITLE <b>Human Engineering Design Data Digest</b>		5a. CONTRACT NUMBER	
		5b. GRANT NUMBER	
		5c. PROGRAM ELEMENT NUMBER	
6. AUTHOR(S)		5d. PROJECT NUMBER	
		5e. TASK NUMBER	
		5f. WORK UNIT NUMBER	
7. PERFORMING ORGANIZATION NAME(S) AND ADDRESS(ES) <b>Department of Defense Human Factors Engineering Technical Advisory Group Washington, DC</b>		8. PERFORMING ORGANIZATION REPORT NUMBER	
9. SPONSORING/MONITORING AGENCY NAME(S) AND ADDRESS(ES)		10. SPONSOR/MONITOR'S ACRONYM(S)	
		11. SPONSOR/MONITOR'S REPORT NUMBER(S)	
12. DISTRIBUTION/AVAILABILITY STATEMENT <b>Approved for public release, distribution unlimited</b>			
13. SUPPLEMENTARY NOTES <b>The original document contains color images.</b>			
14. ABSTRACT			
15. SUBJECT TERMS			
16. SECURITY CLASSIFICATION OF:			17. LIMITATION OF ABSTRACT
a. REPORT <b>unclassified</b>	b. ABSTRACT <b>unclassified</b>	c. THIS PAGE <b>unclassified</b>	<b>SAR</b>
			18. NUMBER OF PAGES <b>158</b>
			19a. NAME OF RESPONSIBLE PERSON

# HUMAN ENGINEERING DESIGN DATA DIGEST

APRIL 2000

HUMAN FACTORS STANDARDIZATION SUBTAG

DEPARTMENT OF DEFENSE  
HUMAN FACTORS ENGINEERING  
TECHNICAL ADVISORY GROUP

## FOREWORD

This digest was prepared by the Human Factors Standardization SubTAG of the Department of Defense Human Factors Engineering Technical Advisory Group (DoD HFE TAG).

This booklet is a digest of material appearing in MIL-STD-1472, and is complemented with material from MIL-HDBK-759 and the Federal Aviation Administration (FAA) Human Factors Design Guide. The user is therefore referred to those documents and its references for required supplementary information.

This digest provides basic, quantitative human engineering design data in pictorial, tabular, and graphical formats for use during system, equipment, or facility design and assessment. Its purpose is to furnish a convenient “portable” reference of human engineering design criteria and guidelines. The principles, explanations, limitations, and application techniques associated with the data have been intentionally omitted. This abbreviated presentation presupposes that the user is familiar with the bases and limitations of the given data or will consult applicable references to ensure appropriate application of the data.

Comments from users of this digest are welcomed and should be submitted to:

Mr. Alan Poston  
Federal Aviation Administration  
AND-202, Room 300W  
800 Independence Avenue, S.W.  
Washington, DC 20591

# TABLE OF CONTENTS

## CONTROL/DISPLAY INTEGRATION

Inch-pound equivalents, abbreviations, and prefixes.....	1
--	---

## VISUAL DISPLAYS

Lines of sight .....	2
Vertical and horizontal visual field.....	3
Coding of simple indicator lights .....	4
Application of various types of mechanical displays.....	5
Scale of markings .....	6
Scale marker dimensions .....	7
Relative position of scale marks, numerals, and pointers on circular dials .....	8
Group viewing of optical projection displays.....	9
Color coding of transilluminated displays .....	10

## AUDIO DISPLAYS

Functional evaluation of audio signals .....	11
Intelligibility criteria for voice communication signals.....	12

## CONTROLS

Control selection criteria .....	13
Recommended manual controls.....	14
Advantages and disadvantages of various types of control coding.....	15
Advantages and disadvantages of common controls .....	16
Minimum edge-to-edge separation distances for controls .....	18
Ball controls.....	19
Cranks.....	20
Foot-operated switches .....	21
Foot-operated controls .....	22
Handwheels .....	24
High-torque J-handles.....	26
Joysticks, isotonic .....	27
Keyboards.....	28
Nominal keyboard characteristics.....	29
Key-operated switch .....	30
Knobs.....	31
Knob detent placement .....	32
Knobs, ganged .....	33
Legend switch.....	34
Levers .....	35
Lever controls .....	36
Mouse .....	41
Pedals.....	42
Leg strength at various knee and thigh angles .....	43

Representative push button applications.....	44
Push buttons.....	45
Push button switches .....	46
Push-pull controls .....	49
Rocker switches .....	50
Rotary selector switch .....	51
Rotary selector controls .....	52
Slide switches .....	55
Thumbwheel, continuous adjustment .....	56
Thumbwheel, discrete.....	57
Toggle switches .....	58
Toggle switch controls.....	59
Touch screens .....	63
Two-axis controllers for display applications.....	64
Grip switches .....	65
Arm, hand, and thumb-finger strength (5 <sup>th</sup> percentile male).....	67

## MARKING AND LABELING

Character height versus luminance .....	69
Luminance contrast ratios for various conditions.....	70
Stroke width for pixel-generated characters .....	71
Height-width relationship for pixel-generated characters.....	71

## ANTHROPOMETRY AND BIOMECHANICS

Static human physical characteristics - head .....	72
Static human physical characteristics - seated.....	76
Static human physical characteristics - standing .....	80
Static human physical characteristics - hands.....	83
Static human physical characteristics - standing position.....	84
Additive effects of clothing on anthropometric measures .....	85
Joint movement ranges .....	87
Muscle strength of the arm, hand, and thumb (5 <sup>th</sup> percentile male).....	90
Static muscle strength data for vertical pull exertions .....	92
Horizontal push and pull forces that can be exerted .....	95
Examples of push force conditions.....	96
Anthropometric data for common working positions .....	97

## WORKSPACE DESIGN

Standard console dimensions.....	102
Standard console dimensions key .....	103
Seated workspace dimensions .....	104
Seated workspace dimensions key.....	105
Standing workspace dimensions.....	106
Standing workspace dimensions key .....	107
Mobile workspace dimensions .....	108
Mobile workspace dimensions key.....	109
Recommended placement areas for controls and displays.....	110
Seated optimum manual control space .....	111
Type of structure in relation to angle of ascent.....	112

Ramp dimensions .....	113
Stair dimensions .....	114
Stair-ladder dimensions .....	115
Fixed-ladder dimensions.....	116
Portable rung-ladder dimensions .....	117
Rung-ladder and ladder-cage dimensions.....	118
Stepladder dimensions .....	119
Walkway and passageway dimensions .....	120
Door dimensions.....	121

## ENVIRONMENT

Effective temperature or corrected effective temperature.....	122
Summer and winter comfort zones and thermal tolerance for inhabited compartments.....	123
Windchill chart .....	124
Equivalent chill temperature.....	125
Human reaction to windchill .....	126
Performance decrement at different ambient temperatures .....	126
Ventilation requirements .....	127
Specific task illumination requirements .....	128
Recommendations for display lighting .....	130
Brightness ratios .....	131
Workspace reflectance values.....	132
Permissible distance between a speaker and listeners .....	133
Range of acceptable reverberation time.....	134

## DESIGN FOR MAINTAINER

Arm and hand access dimensions .....	135
Whole body access opening.....	136
Maximum weight of units to be lifted by one person (male or female).....	137
Maximum design weight limits .....	137
Weight and dimension limits of portable test equipment .....	137
Minimum handle dimensions .....	138
Fastener examples.....	139
Electrical cable coding.....	140
Hydraulic and pneumatic coding .....	141
Values for color-coded fixed resistors and small capacitors.....	142
Color coding of fluid conductors.....	142

## SMALL SYSTEMS AND EQUIPMENT

Anatomical limits on axially symmetrical ocular metal parts.....	143
--	-----

## OPERATIONAL AND MAINTENANCE GROUND/SHIPBOARD VEHICLES

Recommended clearances around equipment operator's station.....	144
Recommended clearances around equipment operator's station key.....	145
Dimensions for vehicle operator's seat.....	146

## HAZARDS AND SAFETY

Temperature exposure limits .....	147
Burn criteria for human skin.....	147
Exposure limit for ultraviolet radiant energy.....	148
Permissible noise exposure.....	149
Shock current intensities and their probable effects .....	150

## USER-COMPUTER INTERFACE

Maximum acceptable system response times .....	151
--	-----



EQUIVALENTS		
TO CONVERT FROM	TO	MULTIPLY BY
candela per square meter (cd/m <sup>2</sup> )	footlambert (fL)	0.291 864
kilogram (kg)	pound (lb) avoirdupois	2.204 623
kilopascals (KPa)	pound force/inch <sup>2</sup> (lbf/in <sup>2</sup> )	0.145 038
lux (lx)	footcandle (fc)	0.092 903
meter (m)	foot (ft)	3.280 840
meter (m)	inch (in. or ")	39.370 079
meter <sup>2</sup> (m <sup>2</sup> )	foot <sup>2</sup> (ft <sup>2</sup> )	10.763 910
meter <sup>2</sup> (m <sup>2</sup> )	inch <sup>2</sup> (in <sup>2</sup> )	1550.003 120
meter <sup>3</sup> (m <sup>3</sup> )	foot <sup>3</sup> (ft <sup>3</sup> )	35.314 662
meter <sup>3</sup> (m <sup>3</sup> )	inch <sup>3</sup> (in <sup>3</sup> )	61203.745 303
millimeter (mm)	inch (in. or ")	0.039 370
millimeter <sup>2</sup> (mm <sup>2</sup> )	inch <sup>2</sup> (in <sup>2</sup> )	0.001 550
newton (N)	pound force (lbf)	0.224 809
newton (N)	ounce force (ozf)	3.596 942
newton meter (N-m)	pound-inch (lbf-in)	8.850 748
newton meter (N-m)	ounce-inch (ozf-in)	141.611 929
radian (rad)	degree (angle)(deg)	57.295 788
radian (rad)	minute (angle)(min)	3437.746 873
PREFIXES		TEMPERATURE CONVERSION
Nano n 10 <sup>-9</sup>	Kilo k 10 <sup>3</sup>	°C = 5/9 (°F - 32)
Micro μ 10 <sup>-6</sup>	Mega M 10 <sup>6</sup>	°F = 9/5 °C + 32
Milli m 10 <sup>-3</sup>		
Centi c 10 <sup>-2</sup>		

## Inch-pound equivalents, abbreviations, and prefixes

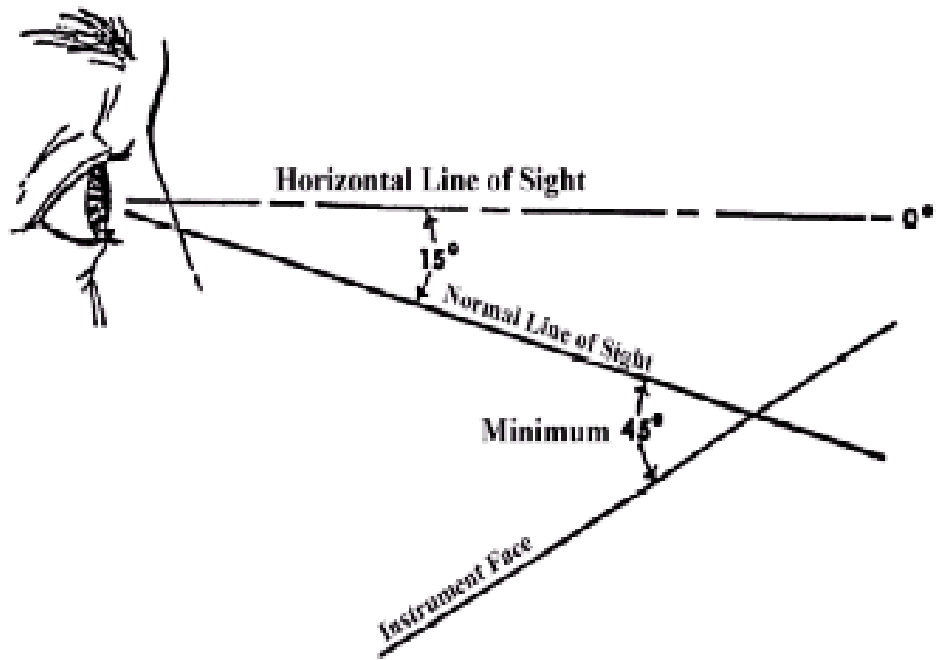

Lines of sight

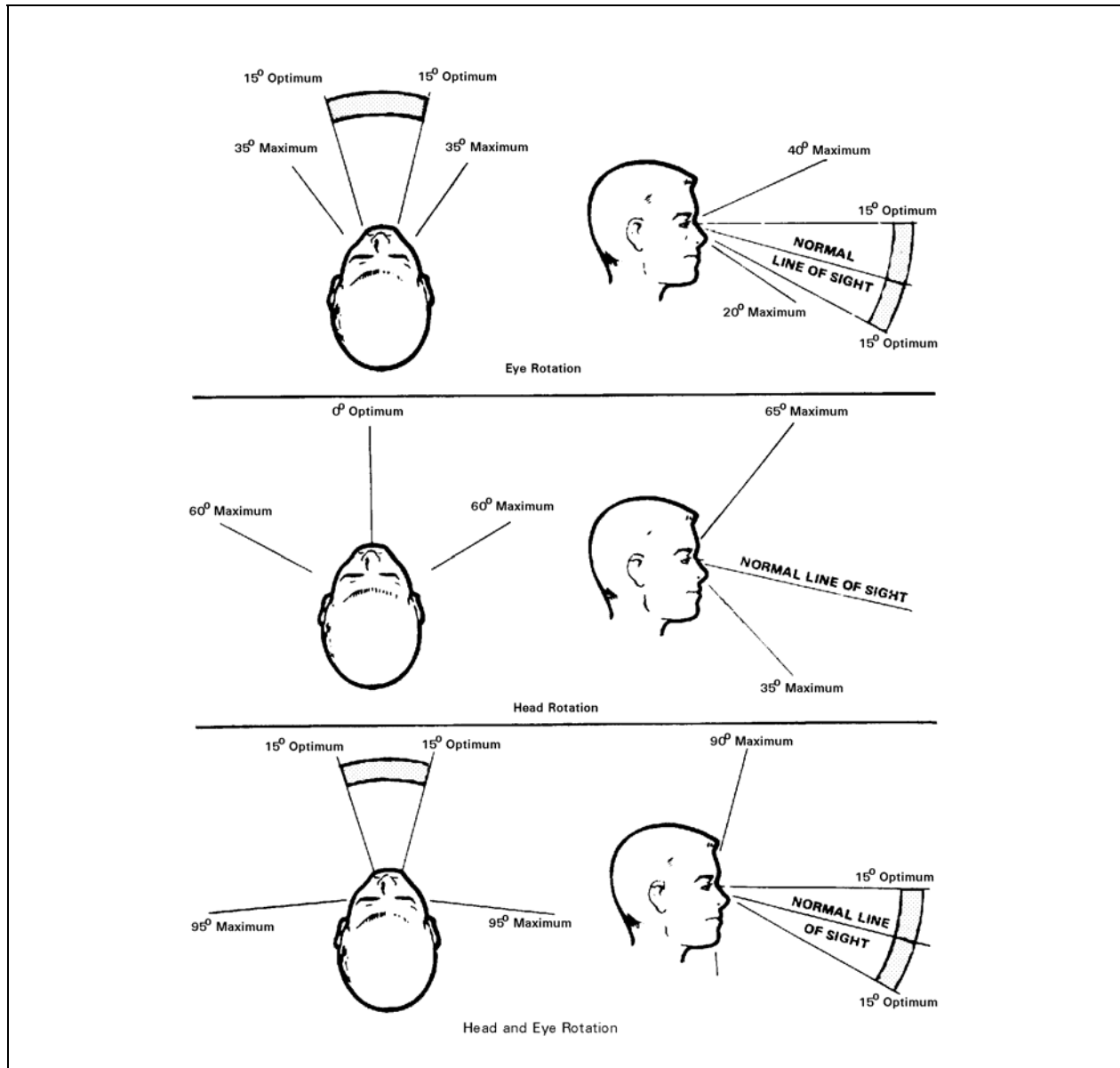

## Vertical and horizontal visual field

SIZE/TYPE	COLOR			
	RED	YELLOW	GREEN	WHITE
$\geq 25$ mm (1 in) FLASHING (3 to 5 sec)	Emergency condition (impending personnel or equipment disaster).			
$\geq 25$ mm (1 in) STEADY	Master summation (system or subsystem)	Extreme caution (impending danger)	Master summation (system or subsystem)	
$\leq 13$ mm (1/2 in) STEADY	Malfunction; action stopped; failure; stop action.	Delay; check; recheck.	Go ahead; in tolerance; acceptable; ready.	Functional or physical position; action in progress

Coding of simple indicator lights

USE	SCALES		COUNTERS	PRINTERS	FLAGS
	Moving Pointer	Fixed Pointer			
QUANTITATIVE INFORMATION	<p>FAIR</p> <p>May be difficult to read while pointer is in motion.</p>	<p>FAIR</p> <p>May be difficult to read while scale is in motion.</p>	<p>GOOD</p> <p>Minimum time and error for exact numerical value; however, cannot be read when changing rapidly.</p>	<p>GOOD</p> <p>Minimum time and error for exact numerical value. Provides reference records.</p>	N/A
QUALITATIVE INFORMATION	<p>GOOD</p> <p>Location of pointer easy. Numbers and scale need not be read. Position change easily detected.</p>	<p>POOR</p> <p>Difficult to judge direction and magnitude of deviation without reading numbers and scale.</p>	<p>POOR</p> <p>Numbers must be read. Position changes not easily detected.</p>	<p>POOR</p> <p>Numbers must be read. Position change not easily detected.</p>	<p>GOOD</p> <p>Easily detected. Economical of space.</p>
SETTING	<p>GOOD</p> <p>Simple and direct relation of motion of pointer to motion of setting knob. Position change aids monitoring.</p>	<p>FAIR</p> <p>Relation to motion of setting knob may be ambiguous. No pointer position change to aid monitoring. Not readable during rapid setting.</p>	<p>GOOD</p> <p>Most accurate monitoring of numerical setting. Relation to motion of setting knob less direct than for moving pointer. Not readable during rapid setting.</p>	N/A	N/A
TRACKING	<p>GOOD</p> <p>Pointer position readily controlled and monitored. Simplest relation to manual control motion.</p>	<p>FAIR</p> <p>No position changes to aid monitoring. Relation to control motion somewhat ambiguous.</p>	<p>POOR</p> <p>No gross position changes to aid monitoring.</p>	N/A	N/A
GENERAL	<p>Requires largest exposed and illuminated area on panel. Scale length limited unless multiple pointers used.</p>	<p>Saves panel space. Only small section of scale need be exposed and illuminated. Use of tape allows long scale.</p>	<p>Most economical of space and illumination. Scale length limited only by number of counter drums.</p>	<p>Limited application.</p>	<p>Limited application.</p>

### Application of various types of mechanical displays

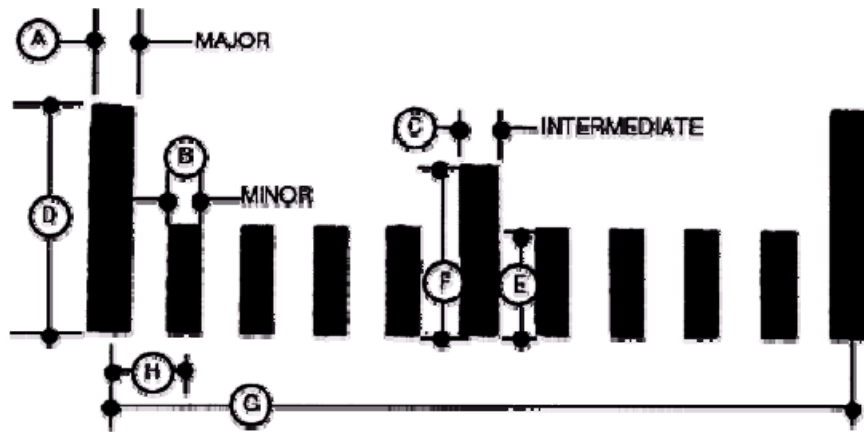

Dimension	Viewing Distance (mm)		
	710	910	1525
A (Major index width)	0.9	1.1	1.9
B (Minor index width)	0.6	0.8	1.4
C (Intermediate index width)	0.8	1.0	1.6
D (Major index height)	5.6	7.2	12.0
E (Minor index height)	2.5	3.3	5.4
F (Intermediate index height)	4.1	5.2	8.7
G (Major index separation between midpoints)	17.8	22.9	38.0
H (Minor index separation between midpoints)	1.8	2.3	3.8

Minimum scale dimensions for low illumination (1-3.4 cd/m<sup>2</sup>)

## Scale of markings

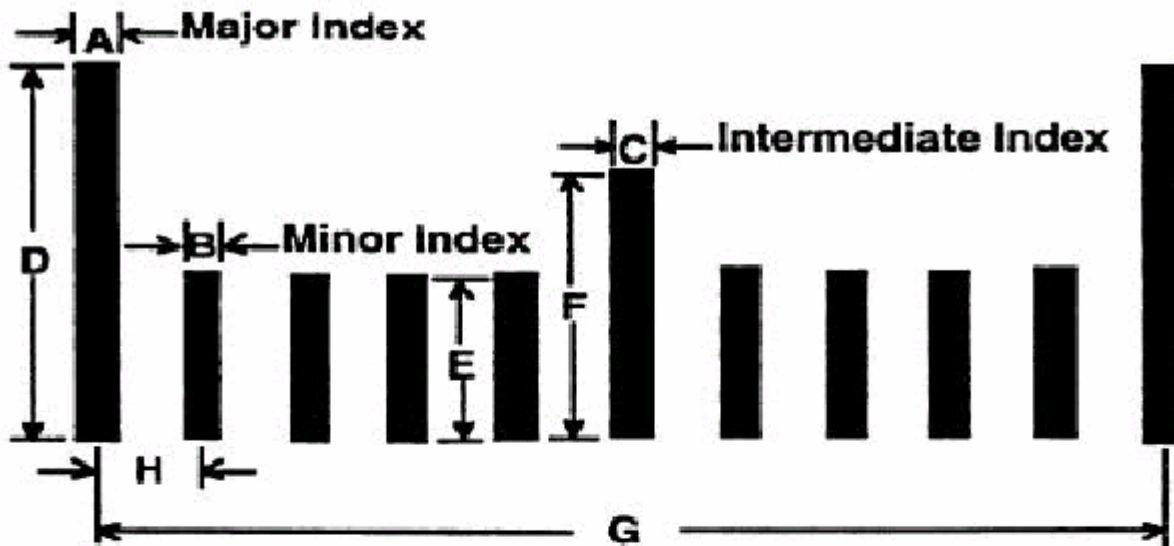

Dimensions of dark markers on light background, visual angle

A	Width of major scale index	1.16 mrad	(4 min)*
B	Width of minor scale index	0.87 mrad	(3 min)*
C	Width of intermediate scale index	1.16 mrad	(4 min)*
D	Length of major scale index	7.86 mrad	(27 min)
E	Length of minor scale index	3.49 mrad	(12 min)
F	Length of intermediate scale index	5.82 mrad	(20 min)
G	Width of gap between major scale index	25.02 mrad	(86 min)
H	Width of gap between minor scale index	2.62 mrad	(9 min)

\*4.36 mrad (15 min) for light markers on dark background

NOTE: For most applications with a dark graduation mark on a light background, the width of the minor graduation mark can be used for major and intermediate graduation marks as well. Use of this strategy allows the width of the pointer tip to be the same as all of the graduation marks. Visual angles are for longest anticipated viewing distance.

### Scale marker dimensions

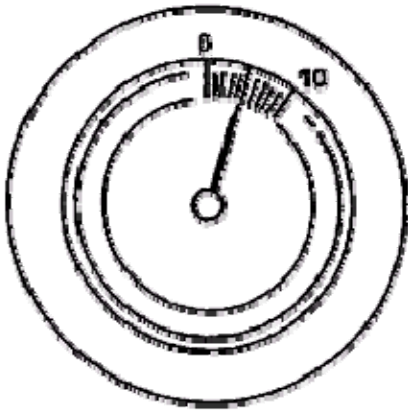

**FOR MAXIMUM READING ACCURACY**  
**(THE POINTER IS AN EQUAL DISTANCE =**  
**NOMINAL 0.8-1.6 mm (0.031-0.061 in.) =**  
**FROM ALL SCALE MARKS. NEVER**  
**OVERLAPPING ANY MARK OR NUMERAL.)**



**ALTERNATE FORMAT FOR GROSS**  
**READING OF NUMBERS**

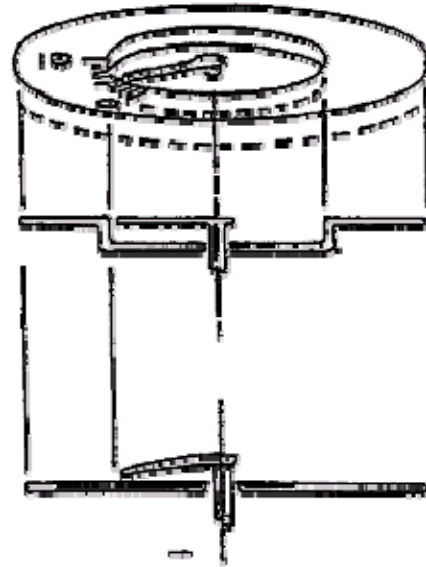

**TO PREVENT OR MINIMIZE VISUAL**  
**PARALLAX**

Relative position of scale marks, numerals, and pointers on circular dials



FACTOR	OPTIMUM	PREFERRED LIMITS	ACCEPTABLE LIMITS
Ratio of $\frac{\text{viewing distance}}{\text{screen diagonal}}$	4	3-6	2-8
Angle off centerline	0°	20°	30°
Image luminance (no film in operating projector)	35 cd/m <sup>2</sup> * (10 ft-L)	27-48 cd/m <sup>2</sup> * (8-14 ft-L)	17-70 cd/m <sup>2</sup> * (5-20 ft-L)
Luminance variation across screen (ratio of maximum to minimum luminance)	1	1.5	3.0
Luminance variation as a function of viewing location (ratio of maximum to minimum luminance)	1	2.0	4.0
Ratio of $\frac{\text{ambient light}}{\text{brightest part of image}}$	0	0.002-0.01	0.1 max**

\* For still projections higher values may be used

\*\* For presentations not involving gray scale or color (e.g., line drawings, tables) 0.2 may be used.

### Group viewing of optical projection displays

<b>Color</b>	<b>Use</b>	<b>Examples</b>
flashing red	to indicate an emergency condition that requires immediate action to avert impending injury, equipment damage, or both	
red	to indicate that (1) the system or a portion of the system is inoperative, or (2) successful task completion is not possible until appropriate corrective or override action is taken	“no-go” “error” “failure” “malfunction”
yellow	to indicate (1) a marginal condition, (2) an unexpected delay, (3) that caution is necessary, or (4) that rechecking is necessary	
green	to indicate that (1) equipment is “in tolerance,” (2) conditions are satisfactory, or (3) it is all right to proceed	“go ahead” “in tolerance” “ready” “function activated”
white	to indicate system conditions that do not have “right” or “wrong” implications	(1) indicating which of several functions has been selected, (2) indicating a transitory condition such as an action or test in progress, provided such indications have no implications of success or failure
blue	to advise only	

## Color coding of transilluminated displays

FUNCTION	TYPE OF SIGNAL		
	TONES (Periodic)	COMPLEX SOUNDS (Non-Periodic)	SPEECH
QUANTITATIVE INDICATION	<u>POOR</u> Maximum of 5 to 6 tones absolutely recognizable	<u>POOR</u> Interpolation between signals inaccurate.	<u>GOOD</u> Minimum time and error in obtaining exact value in terms compatible with response.
QUALITATIVE INDICATION	<u>POOR-TO-FAIR</u> Difficult to judge approximate value and direction of deviation from null setting unless presented in close temporal sequence.	<u>POOR</u> Difficult to judge approximate deviation from desired value.	<u>GOOD</u> Information concerning displacement, direction, and rate presented in form compatible with required response.
STATUS INDICATION	<u>GOOD</u> Start and stop timing. Continuous information where rate of change of input is low.	<u>GOOD</u> Especially suitable for irregularly occurring signals (e.g., alarm signals).	<u>POOR</u> Inefficient; more easily masked; problem of repeatability.
TRACKING	<u>FAIR</u> Null position easily monitored; problem of signal-response compatibility	<u>POOR</u> Required qualitative indications difficult to provide.	<u>GOOD</u> Meaning intrinsic in signal.
GENERAL	Good for automatic communication of limited information. Meaning must be learned. Easily generated.	Some sounds available with common meaning (e.g., fire bell). Easily generated.	Most effective for rapid (but not automatic) communication of complex, multi-dimensional information. Meaning intrinsic in signal and context when standardized. Minimum of new learning required.

## Functional evaluation of audio signals

COMMUNICATION REQUIREMENT	SCORE		
	PB	MRT	AI <sup>1</sup>
Exceptionally high intelligibility; separate syllables understood	90%	97%	0.7
Normal acceptable intelligibility; about 98% of sentences correctly heard; single digits understood	75%	91%	0.5
Minimally acceptable intelligibility; limited standardized phrases understood; about 90% sentences correctly heard (not acceptable for operational equipment)	43%	75%	0.3

<sup>1</sup> The Articulation Index (AI) should not be used to measure intelligibility of synthetic speech because some key acoustic features are not present in non-human “speech.” Instead, intelligibility of synthetic speech should be measured using representative panels of talkers and listeners.

## Intelligibility criteria for voice communications signals

FUNCTION	CONTROL									
	Selector Switch	Round Knob	Discrete Thumb Wheel	Cont. Thumb Wheel	Crank Button	Push Button	Toggle Switch	Rocker Switch	Lever	Joystick, Ball, Mouse
Select power state ON-OFF	3					1	2	2	2	1a
3-State (OFF-STBY-ON)	1						2	2	3	
Select between OFF/Prime Mode/Secondary Mode(s)	1					2	3	3	3	1a
Select one or more of N related functions						1	2	2	2	
Select one of N mutually exclusive functions of any order						1				
Select one of 3-24 discrete alternatives - sequential order	1									
Select digit - discrete	2b		2b			1c				
Set value on - continuous scale					2	3				
Select value in - discrete steps	1		1							3
Select operating condition	2					1	1	1	1	2
Enter alphanumeric data						1c				
Initiate test subfunction (momentary)	3					1	1	1	2	
Initiate directional function	3			3		2d	1	1d	1	
Generate stepping impulse (momentary hold)						1	1	1	2	
Slew counters or other numeric readout						1e	1	1	1	
Reset mechanical counter, manual						1	3	1		
Interrupt sequence, 'hold'										
Engage - disengage mechanical function						1	1	2	2	
Adjust light level, continuous	1	3	1							1
Adjust sound level, continuous	1	3	1							3
Coarse adjustment	1g		2h	2i						2j
Fine adjustment	1k		2l	2m						3n
Adjust to null position	1		2	3						3
Single-coordinate tracking	3				2					1
Two-coordinate tracking					3					1

1 = most preferred; 3 = least preferred

- NOTES:
- a - Lever for heavy duty power circuits
  - b - Only if sequential selection is acceptable
  - c - Keyboard
  - d - Multiple controls
  - e - Rate control
  - f - Manual only
  - g - Small diameter
  - h - Small motion
  - i - Few turns
  - j - Short throw
  - k - Large diameter
  - l - Large motion
  - m - Many turns
  - n - Long throw

### Control selection criteria

CONTROL FUNCTION	CONTROL TYPE
<u>Small actuation force required:</u>	
2 Discrete positions	Keylock Push button Toggle switch Legend switch Slide switch
3 Discrete positions	Rotary selector switch Toggle switch Push button
4 to 24 Discrete positions	Rotary selector switch
Continuous setting (linear and less than 360°)	Continuous rotary knob Joystick or lever
Continuous slewing and fine adjustment	Crank Continuous rotary knob
<u>Large actuation force required:</u>	
2 Discrete positions	Foot push button Hand push button Detent lever
3 to 24 Discrete positions	Detent lever Rotary selector switch
Continuous setting (linear and less than 360°)	Handwheel Joystick or lever Crank Two-axis grip handle
Continuous setting (more than 360°)	Crank Handwheel Valve Two-axis grip handle

### Recommended manual controls

ADVANTAGES	TYPE OF CODING					
	LOCATION	SHAPE	SIZE	MODE OF OPERATION	LABELING	COLOR
Improves visual identification.	X	X	X		X	X
Improves nonvisual identification (tactual and kinesthetic).	X	X	X	X		
Helps standardization.	X	X	X	X	X	X
Aids identification under low levels of illumination and colored lighting.	X	X	X	X	(When trans-illuminated)	(When trans-illuminated)
May aid in identifying control position (settings).		X		X	X	
Require little (if any) training; is not subject to forgetting.					X	
<b>DISADVANTAGES</b>						
May require extra space.	X	X	X	X	X	
Affects manipulation of the control (ease of use).	X	X	X	X		
Limited in number of available coding categories.	X	X	X	X		X
May be less effective if operator wears gloves.		X	X	X		
Controls must be viewed (i.e., must be within visual areas and adequately illuminated).					X	X

### Advantages and disadvantages of various types of control coding

Advantages	Disadvantages
<p><b>A. Knob, discrete position rotary</b></p> <p>Used when 4 or more detented positions are required; resistant to accidental actuation</p>	<p>Not recommended for 2 position functions; relatively slow</p>
<p><b>B. Knob, continuous position rotary</b></p> <p>Good for precise settings; single- or multi-turn capability</p>	<p>Potential parallax error; relatively slow; susceptible to misinterpretation if multiple turn; sensitive to accidental activation; difficult (time consuming) to re-establish setting if switch is moved inadvertently</p>
<p><b>C. Knobs, ganged</b></p> <p>Efficient use of space</p>	<p>Three-knob assembly not recommended; relatively slow; not recommended for gloved use; susceptible to erroneous settings; not recommended when frequent changes are required; one knob may move other knob if inter-knob friction exists (may require two-handed operation)</p>
<p><b>D. Thumbwheels</b></p> <p>Compact; virtually an unlimited range</p>	<p>Not recommended for fine control; slow, not recommended for high traffic functions; can cause intermediate and inadvertent inputs; susceptible to inadvertent activation; position or selection may be difficult to assess in dim light</p>
<p><b>E. Cranks</b></p> <p>Used when multiple rotations are required; fast; can handle high forces; with proper gearing can be used for either gross or fine positioning over a wide range of adjustments</p>	<p>Requires space; susceptible to accidental movement</p>
<p><b>F. Handwheels</b></p> <p>Good for high forces; suitable for two-handed use</p>	<p>Requires substantial space; not good for fine adjustments; may require two-handed operation</p>
<p><b>G. Levers</b></p> <p>Good for high forces; status is obvious</p>	<p>Large space requirements; susceptible to accidental displacement; not recommended for fine control</p>
<p><b>H. Toggle switches</b></p> <p>Used for 2 or 3 discrete positions; efficient use of space; setting is obvious to user</p>	<p>Four or more positions should be avoided; susceptible to inadvertent activation; often requires guards or shields</p>

## Advantages and disadvantages of common controls



<b>I. Push button</b>	Efficient use of space; fast activation	State of activation is not always obvious; susceptible to accidental activation; may require secondary status indication; bulb failure can lead to erroneous interpretation of status
<b>J. Foot operated switches</b>	Can be used when hands are occupied	Susceptible to accidental activation; not recommended for critical operations, frequent use, or fine adjustments
<b>K. Pedals</b>	Use when both hands occupied; high force capability; may be used where pedal has created a stereotyped expectancy	Requires large amount of space for location and operation; susceptible to accidental activation due to them being unseen or felt (without danger of activation); controls or settings are easily identified
<b>L. Rocker switches</b>	Efficient use of space; will not snag clothing; status is obvious	Susceptible to accidental activation; can be difficult to read three-position rocker switches
<b>M. Push-pull controls</b>	Used for 2 position control; efficient use of panel space; may be used in multi-mode fashion (for example, on-off and volume control) to save space	Difficult to determine positions when used for multiple position control; susceptible to inadvertent activation
<b>N. Slide switches</b>	Can be discrete or continuous; good for large number of discrete positions; provides easy recognition of relative switch setting	Continuous slide switches susceptible to mispositioning; can be difficult to position continuous slide switch precisely
<b>O. Legend switches</b>	Good in low illumination (if self illuminated); fast activation; effective way to label switches; efficient use of panel space	Not recommended for more than two positions; state of activation is not always obvious
<b>P. Printed circuit (DIP) switches</b>	Very space efficient	Slow; usually require stylus to set; small size makes it difficult to read; may require stabilized hand to set and to avoid excess force
<b>Q. Key operated switches</b>	Prevents unauthorized operation; permits flush panel for seldom operated switches	Slow to operate; must keep track of separate key; key slot susceptible to contamination if not shielded

Advantages and disadvantages of common controls (continued)

	TOGGLE SWITCHES	PUSH BUTTONS*	CONTINUOUS ROTARY CONTROLS	ROTARY SELECTOR SWITCHES	DISCRETE THUMBWHEEL CONTROLS
TOGGLE SWITCHES	SEE FIG 14	13 mm (0.5 in)	19 mm (0.75 in)	19 mm (0.75 in)	13 mm (0.5 in)
PUSH BUTTONS <sup>1</sup>	13 mm (0.5 in)	SEE FIG 12	13 mm (0.5 in)	13 mm (0.5 in)	13 mm (0.5 in)
CONTINUOUS ROTARY CONTROLS	19 mm (0.75 in)	13 mm (0.5 in)	SEE FIG 8	25 mm (1.0 in)	19 mm (0.75 in)
ROTARY SELECTOR SWITCHES	19 mm (0.75 in)	13 mm (0.5 in)	25 mm (1.0 in)	SEE FIG 5	19 mm (0.75 in)
DISCRETE THUMBWHEEL CONTROLS	13 mm (0.5 in)	13 mm (0.5 in)	19 mm (0.75 in)	19 mm (0.75 in)	SEE FIG 7

<sup>1</sup>for pushbuttons not separated by barriers

NOTE: All values are for one hand operation.

Minimum, edge-to-edge separation distances for controls

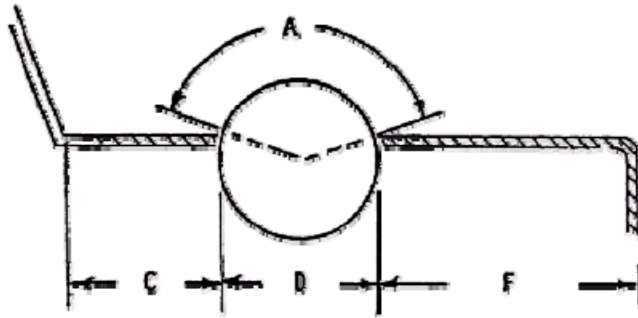
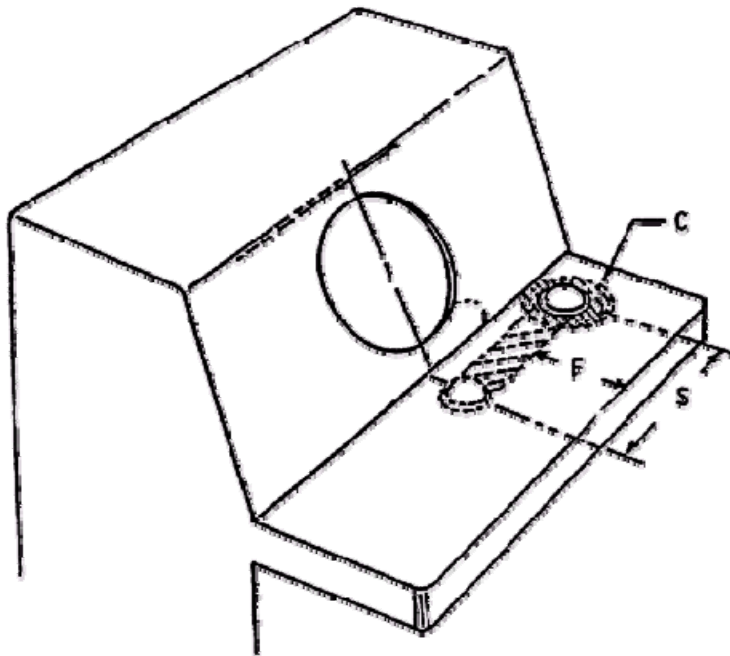

	DIMENSIONS		RESISTANCE		CLEARANCE		
	D DIAM	A SURFACE EXPOSURE	PRECISION REQUIRED	VIBRATION OR ACCEL CONDITIONS	S DISPLAY CL TO BALL CL	C AROUND BALL	F BALL TO SHELF FRONT
MINIMUM	50 mm (2.0")	100°	0.25 N (0.9 oz)	—	0	50 mm (2.0")	120 mm (4.75")
PREFERRED	100 mm (4.0")	120°	0.3 N (1.1 oz)	—	—	—	—
MAXIMUM	150 mm (6.0")	140°	1.5 N (5.4 oz)	1.7 N (6.0 oz)	320 mm (12.5")	—	250 mm (10")

NOTE: Initial resistance should range from 0.25 N(0.9 oz) to 0.4 N (1.4 oz).

## Ball controls

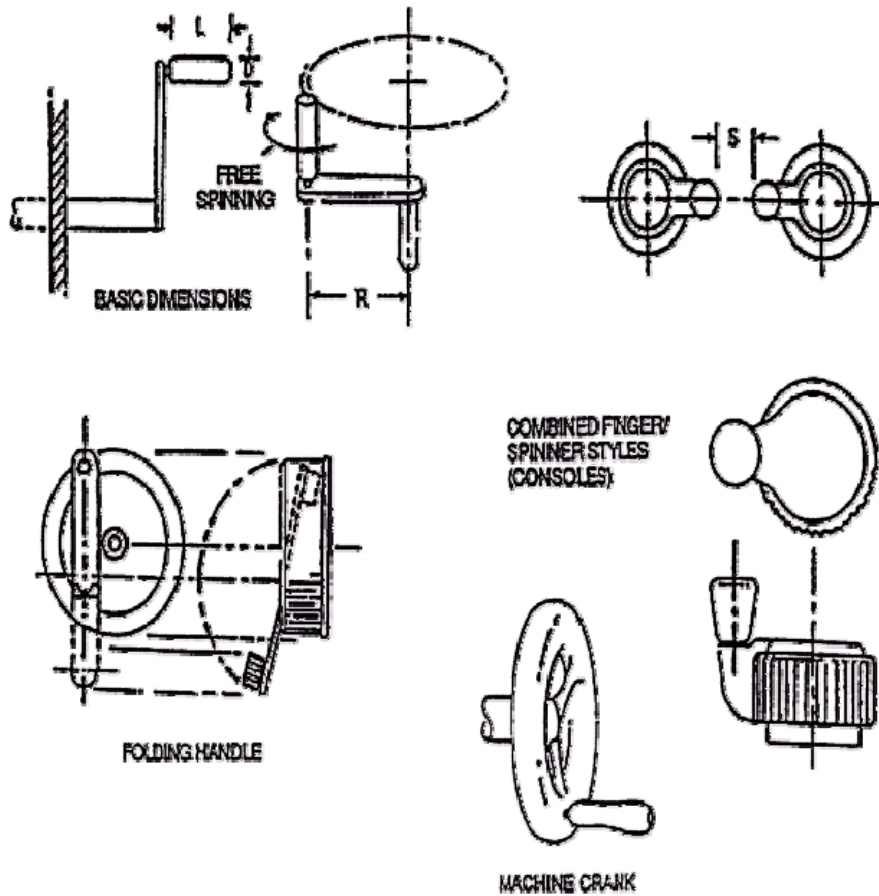

LOAD	DIMENSION	HANDLE		R, TURNING RADIUS	
		L, LENGTH	D, DIAMETER	RATE BELOW 100 RPM	RATE ABOVE 100 RPM
LIGHT LOADS <22 N (5 lb): Wrist & finger movement	MINIMUM	25 mm (1.0 in.)	10 mm (0.4 in.)	38 mm (1.5 in.)	13 mm (0.5 in.)
	PREFERRED	38 mm (1.5 in.)	13 mm (0.5 in.)	75 mm (3.0 in.)	65 mm (2.5 in.)
	MAXIMUM	75 mm (3.0 in.)	16 mm (0.625)	125 mm (5.0 in.)	115 mm (4.5 in.)
HEAVY LOADS >22 N (5 lb): Arm movement	MINIMUM	75 mm (3.0 in.)	25 mm (1.0 in.)	190 mm (7.5 in.)	125 mm (5.0 in.)
	PREFERRED	95 mm (3.75 in.)	25 mm (1.0 in.)	—	—
	MAXIMUM	—	38 mm (1.5 in.)	510 mm (20 in.)	230 mm (9.0 in.)

S, Separation between adjacent controls: 75 mm (3"), minimum.

## Cranks

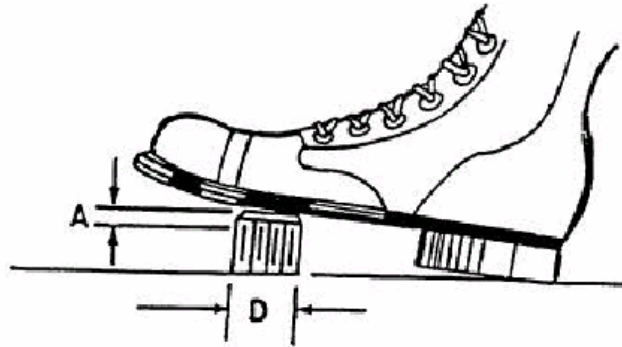

	DIAMETER	RESISTANCE		DISPLACEMENT			
	D	Foot Will <u>Not</u> Rest On Control	Foot Will Rest On Control	Normal Operation	Heavy Boot Operation	Ankle Flexion Only	Total Leg Movement
Minimum	13 mm (0.5 in.)	18 N (4 lb)	45 N (10 lb)	13 mm (0.5 in.)	25 mm (1 in.)	25 mm (1 in.)	25 mm (1 in.)
Maximum		90 N (20 lb)	90 N (20 lb)	65 mm (2.5 in.)	65 mm (2.5 in.)	65 mm (2.5 in.)	100 mm (4 in.)

### Foot-operated switches



DESIGN GUIDELINES

APPLICATION GUIDELINES	DIMENSIONS	DISPLACEMENT	SEPARATION
<p>Pedal applications: Clutch or brake. Convex tread surface.</p> <p>Force requirements: Clutch = 450 N max Brake = 70 N min; 450 N max</p> <p>Alternative pedal shape &amp; spacing. Convex tread surface.</p>	<p><math>W \times D</math> - Min = 75 x 50 mm</p> <p><math>H \times L</math> - Min = 90 x 75 mm</p>		<p>S - Min to prevent foot slipping between pedals = 50 mm</p> <p>S - Min separation to allow foot to pass between pedals = 125 mm; 180 mm for heavy boots</p>
<p>Round pedal shape acceptable. Flat tread surface.</p>	<p><math>\phi</math> - Min = 57 mm</p> <p>S - Comfort separation = 305 <math>\pm</math> 50 mm Max = 405 mm Min = 280 mm</p>		<p>(Note: Edge to edge pedal separations of between 50 mm and 115 mm should generally be avoided because of possibility of getting foot caught.)</p>
<p>Accelerator pedal applications:</p> <p>a. Floor-hinged, full pedal</p> <p>b. Suspended pedal (pedal should be free-swivel)</p> <p>Action displacement envelope. Nominal cruise angle should cause lower leg and foot included angle to be between 90°-105°.</p> <p>Force requirements: max = 90 N; min = 1.5 N</p>	<p>H - Min = 50 mm</p> <p>L<sub>1</sub> = 255 <math>\pm</math> 50 mm</p> <p>L<sub>2</sub> - Min = 90 mm</p>	<p>A - Rest to activate Max = 180 mm Min = 235 mm Preferred = 65 - 100 mm</p> <p>B - Displacement max = 30° (20° with heavy boots)</p>	

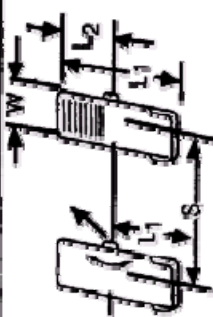
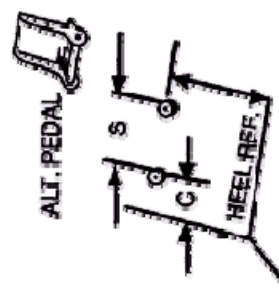
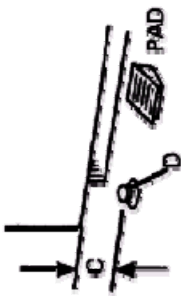
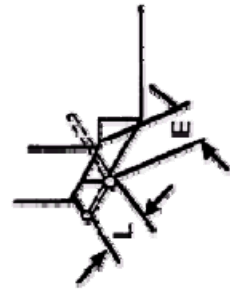
Foot-operated controls

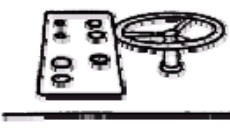

DESIGN GUIDELINES		DIMENSIONS		DISPLACEMENT		SEPARATION	
	<p>Aircraft rudder and brake assembly. Should have min fore-aft adjustment of 230 mm. Toe pressure operates brakes; fore-aft movement of pedal filament operates rudder.</p> <p>Force requirements: See MIL-7-8785.</p>	<p>M - Min = 150 mm</p>	<p>L<sub>1</sub> - Min = 255 mm</p> <p>L<sub>2</sub> - Min = 125 mm</p>			<p>S - Min = 380 mm max</p> <p>W - 530 mm</p>	
		<p>Foot switches. Normally use only one per foot (max two). Force requirements: max 1.5 N (See MIL-8-9584 for specific dimensions.)</p>	<p>D - Diameter min = 25 mm</p>	<p>H - Distance from heel reference = 189-355 mm</p>	<p>C - Clearance to obstruction min = 75 mm</p>	<p>Min = 15 mm</p> <p>Max = 65 mm</p> <p>For boots, increase min to 25 mm</p>	
	<p>Foot switches, stand options: Normal, frequent activation; speed not critical.</p> <p>Force requirements: Preferred max = 90 N</p>	<p>D - Button diameter min = 25 mm; larger preferred</p>		<p>C - Clearance beneath undepressed bar for toe min = 65 mm; 75 mm with boots</p>			
		<p>E - Extension min = 100 mm</p>	<p>L - Accessible to either feet, full width of the expected work envelope</p>				
	<p>Emergency operation, speed important</p>						

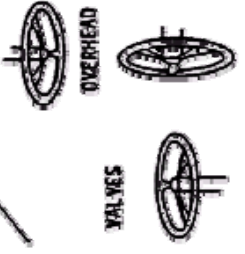
Foot-operated controls (continued)

CONFIGURATION EXAMPLE	APPLICATION CRITERIA	DESIGN CRITERIA				DISPLACEMENT	SEPARATION
		DIMENSIONS		MIN HAND CLEARANCE			
		DIAMETER	RIM DIAM				
	CONTINUOUS ADJUSTMENT FOR ALTERNATE SLEWING/PRECISE POSITIONING, USING DISPLAY REFERENCE. RESISTANCE LOW (e.g., BELCON 110 N (25 lb))	200-510 mm (8-20")	19-32 mm (0.75-1.25")	75 mm (3") around rim	See controls/display ratios 5.1.4	710 mm (28") elbow-elbow clearance	
	CONTINUOUS LOCK-UNLOCK OPERATION	200 mm (8") for 22 N (5 lb) to 300 mm (12") for 155 N (35 lb)	19-32 mm (0.75-1.25")	75 mm (3") around rim	N/A	710 mm (28") elbow-elbow clearance	
	HIGH TORQUE VALVES	200-300 mm (8-16") for overhead; 200-510 mm (8-20") for other positions; 300-350 mm (12-14") by standing surface	19-32 mm (0.75-1.25")	75 mm (3") around rim	See 5.1.4 when applicable	710 mm (28") elbow-elbow clearance 100 - 150 mm (4.0 - 6.0 in) overhead valve rim-to-rim clearance	

## Handwheels

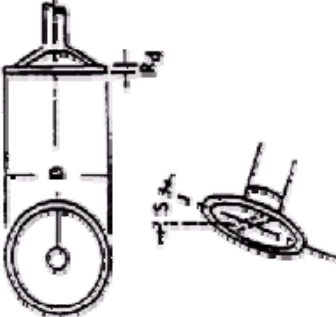

CONFIGURATION EXAMPLE	APPLICATION CRITERIA	DESIGN CRITERIA				SEPARATION
		DIMENSIONS		DISPLACEMENT	S. SLOPE	
		D, DIAMETER	R <sub>d</sub> , RADIUS			
	VEHICLES STEERING (AUTOMOTIVE) MAX RESISTANCE POWER STEERING MAX NON-POWER = 220 N (50 lbf)	19-22 mm (0.75-1.125")	325 mrad (36°) for light vehicle (preferred) 285 mrad (33°) for heavy vehicle (preferred)	Max $\alpha$ = 23 mrad (126°) when both hands must remain on wheel	N/A	
	AIRCRAFT STEERING (COMBINE WHEEL FOR PITCH, RUDDER PEDALS FOR ROLL/STEER)	12 mm (1/25") preferred	L, GRIP LENGTH	X-Y GRIP TILT X = 262 mrad (30°) (45°) Y = 0-262 mrad (0-30°) preferred	N/A	

Handwheels (continued)

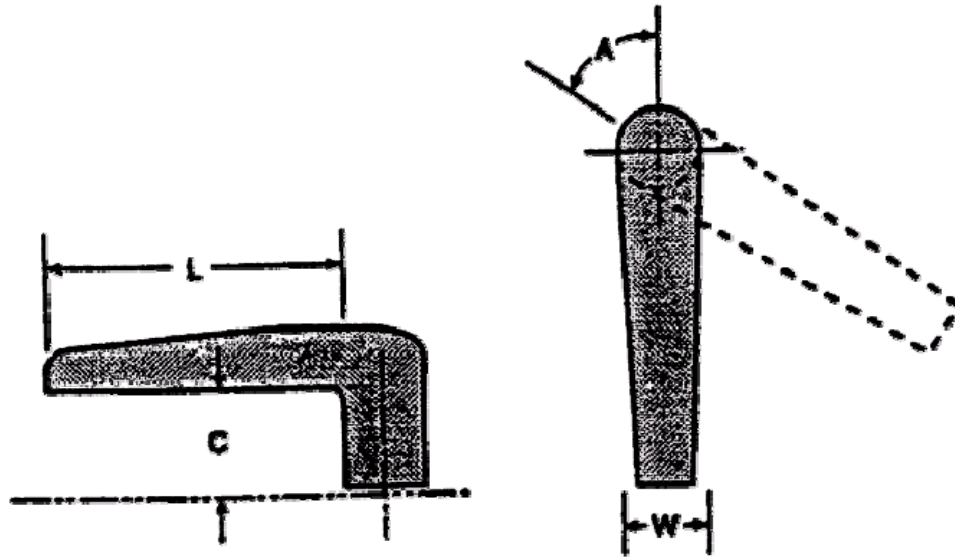

	L LENGTH	C CLEARANCE	W WIDTH	A DISPLACEMENT	RESISTANCE
MINIMUM	95 mm (3.75")	32 mm (1.25")	16 mm (0.65")	± 24°	0.7 N•m (6 lb•in)
MAXIMUM	150 mm (6")	50 mm (2")	25 mm (1")	± 60°	0.14 N•m (12 lb•in)

### High-torque J-handles

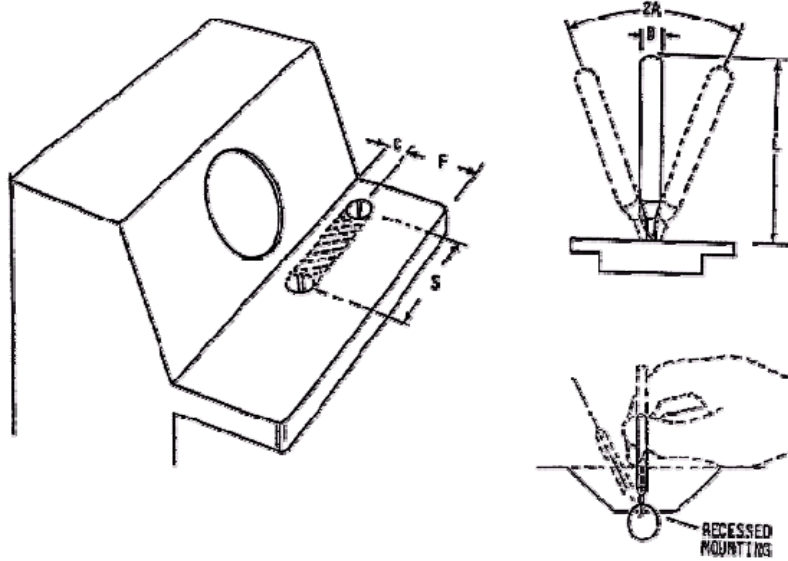

	DIMENSIONS		RESISTANCE	DISPLACEMENT A	CLEARANCE		
	D DIAM	L LENGTH			S DISPLAY CL TO STICK CL	C AROUND STICK	F STICK CL. TO SHELF FRONT
MINIMUM	6.5 mm (0.25")	75 mm (3")	3.3 N (12 oz.)		0	*	120 mm (4.75")
MAXIMUM	16 mm (0.625")	150 mm (6")	8.9 N (32 oz.)	$\frac{\pi}{4}$ rad (45°)	400 mm (15.75")		250 mm (10")

\*Maximum stick excursion plus 100 mm (4").

## Joysticks, isotonic

	DIMENSIONS		RESISTANCE		
	Diameter (D) <sup>1</sup>		Numeric	Alpha-numeric	Dual Function
	Bare hand	Arctic mittens <sup>2</sup>			
Minimum	10 mm (0.4")	19 mm (0.75")	1 N (3.5 oz)	0.25 N (0.9 oz)	0.25 N (0.9 oz)
Preferred	13 mm (0.5")	19 mm (0.75")	-	0.5 - 0.6 N (1.8-2.2 oz)	-
Maximum	19 mm (0.75")	-	4 N (14.0 oz)	1.5 N (5.3 oz)	1.5 N (5.3 oz)
	DISPLACEMENT <sup>3</sup>			SEPARATION	
	Numeric	Alpha-numeric	Dual Function	(between adjacent key tops)	
Minimum	0.8 mm (0.03")	1.3 mm (0.05")	0.8 mm (0.03")	6.4 mm (0.25")	
Preferred	-	-	-	6.4 mm (0.25")	
Maximum	4.8 mm (0.19")	6.3 mm 0.25 in	4.8 mm (0.19")	-	

	VEHICLE APPLICATIONS			
	DIMENSIONS		RESISTANCE	SEPARATION
	Bare hand	Gloved hand	Numeric Input	
Minimum	10 mm (0.4")	19 mm (0.75")	2.8 N (9.9 oz)	-
Preferred	-	-	-	13 mm (0.5")
Maximum	25 mm (1.0")	25 mm (1.0")	6.7 N (23.7 oz)	-

<sup>1</sup>See Figure 12

<sup>2</sup>Trigger finger type; other parameters are unchanged from those of bare-handed operation.

<sup>3</sup> For membrane keys, preferred displacement is 0.7 mm (0.03) and resistance should be not less than 2 N (7.2 oz). Membrane keys should also incorporate positive tactile feedback (e.g., "snap" action).

## Keyboards

Telephone	
<p>A diagram of a standard telephone keypad. It shows a 3x3 grid of keys labeled 1-9, with a 4th row containing keys for 0, *, and #. Dimensions are indicated: 'S' is the horizontal separation between columns, 'H' is the vertical height of a key, 'X' is the depressed extension (the distance the key is pushed down), and 'C/C' is the center-to-center spacing between keys.</p>	<p>K - Key Size = 9 mm  S - Separation = 6 mm  H - Height = 6 mm  X - Depressed Extension = 2 mm  C/C - Center to Center Spacing = 17 mm</p> <p>NOTE: For other dimensions refer to Table 10 for single finger push buttons.</p>
Typewriter	
<p>A diagram of a typewriter keyboard layout. It shows three rows of keys. Dimensions are indicated: 'K' is the key size (width), and 'C/C' is the center-to-center spacing between keys.</p>	<p>K - Key Size = 13 mm  C/C - Center to Center Spacing = 19 mm</p> <p>D - Displacement = 5 mm for electric; 2 mm for typical manual machine</p> <p>A - Varies widely; preferred slope is between 16-17°</p>
<p>A side view diagram of a typewriter keyboard. It shows the keys on a sloped base. 'D' is the vertical displacement of the keys from the base, and 'A' is the angle of the base.</p>	<p>A sloped view diagram of a typewriter keyboard. It shows the keys on a sloped base. 'D' is the vertical displacement of the keys from the base, and 'A' is the angle of the base.</p>

Nominal keyboard characteristics

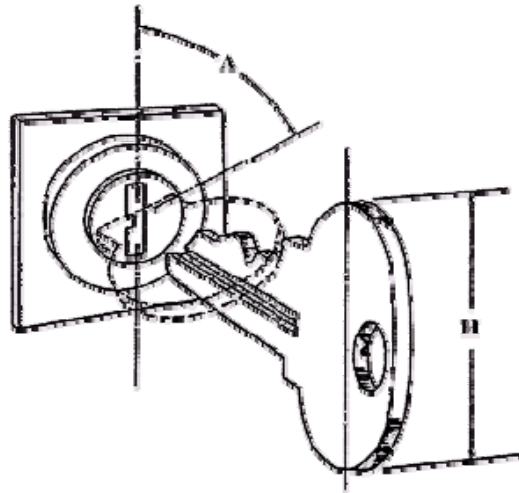

	DISPLACEMENT (A)	HEIGHT (H)	RESISTANCE
MINIMUM	525 mrad (30°)	13 mm (0.5 in.)	115 mN·m (1 in. -lb)
MAXIMUM	1570 mrad (90°)	75 mm (3 in.)	680 mN·m (6 in. -lb)

### Key-operated switch

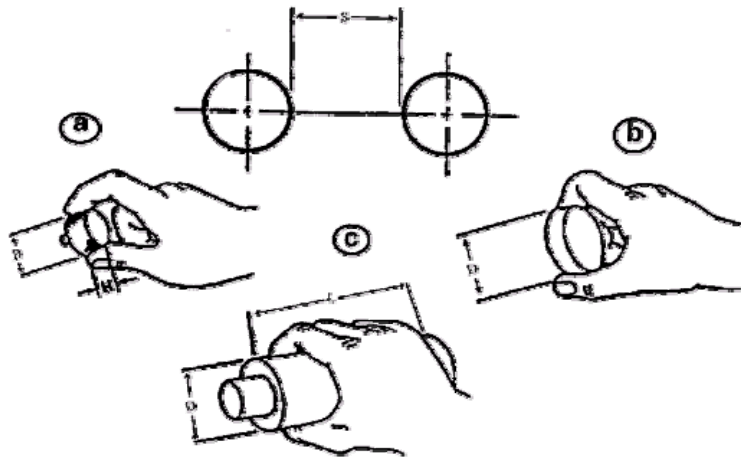

DIMENSIONS						
	a Fingertip Grasp		b Thumb and Finger Encircled		c Palm Grasp	
	H Height	D Diameter	H Height	D Diameter	D Diameter	L Length
Minimum	13 mm (0.5 in.)	10 mm (0.4 in.)	13 mm (0.5 in.)	25 mm (1.0 in.)	38 mm (1.5 in.)	75 mm (3.0 in.)
Maximum	25 mm (1.0 in.)	100 mm (4.0 in.)	25 mm (1.0 in.)	75 mm (3.0 in.)	75 mm (3.0 in.)	-

	TORQUE		SEPARATION	
	*	**	S One Hand Individually	S Two Hands Simultaneously
Minimum	-	-	25 mm (1.0 in.)	50 mm (2.0 in.)
Optimum	-	-	50 mm (2.0 in.)	125 mm (5 in.)
Maximum	32 mN·m (4.5 in. -oz)	42 mN·m (6.0 in. -oz)	-	-

\* = 25 mm (1.0 in) diameter knobs

\*\*> 25 mm (1.0 in) diameter knobs.

## Knobs

Total No. of Settings	Recommended Starting Position (Degrees)			Recommended Angular Displacement (Degrees)	Recommended Radius for 13 mm Separation (mm)
	Left-Hand Operation	Right-Hand Operation	Either Hand		
3	15	265	320	40	20
4	350	255	300	40	20
5	325	245	285	35	20
6	305	235	205	35	20
7	285	225	255	35	20
8	265	215	240	35	20
9	250	210	230	30	20
10	230	200	215	30	25
11	215	195	205	30	25
12	0, 90 or 180	180, 270 or 360	0 or 180	30	25

### Knob detent placement



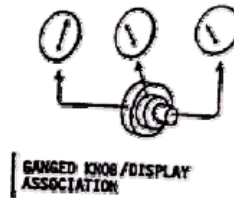
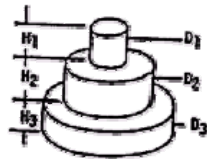
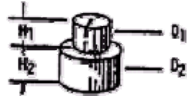

		DIMENSIONS									
		TWO KNOB ASSEMBLY				THREE KNOB ASSEMBLY					
		H <sub>1</sub>	H <sub>2</sub>	D <sub>1</sub>	D <sub>2</sub>	H <sub>1</sub>	H <sub>2</sub>	H <sub>3</sub>	D <sub>1</sub>	D <sub>2</sub>	D <sub>3</sub>
MINIMUM		16 mm (0.625")	13 mm (0.5")	13 mm (0.5")	22 mm (0.875")	19 mm (0.75")	19 mm (0.75")	6 mm (0.25")	13 mm (0.5")	44 mm (1.75")	75 mm (3")
MAXIMUM					100 mm (4")						100 mm (4")
		TORQUE		SEPARATION							
		*	**	ONE HAND INDIVIDUALLY		TWO HANDS SIMULTANEOUSLY					
			BARE	BARE	GLOVED	BARE	GLOVED				
MINIMUM				25 mm (1")	63 mm (2.5")	50 mm (2")	90 mm (3.5")				
OPTIMUM				50 mm (2")	90 mm (3.5")	75 mm (3")	100 mm (4")				
MAXIMUM		32 mN·m (4.5 in. -oz.)	42 mN·m (6 in. -oz.)								

\* To and including 25 mm (1") diameter knobs.  
 \*\* Greater than 25 mm (1") diameter knobs.

## Knobs, ganged

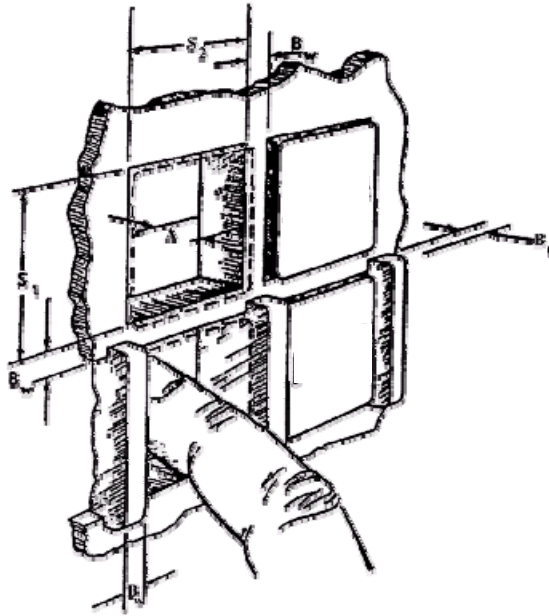

	SIZE (S <sub>1</sub> AND S <sub>2</sub> )		BARRIERS	
	Bare Hand	Gloved Hand	Width (Bw) <sup>2</sup>	Depth (Bd)
MINIMUM	19 mm (0.75") <sup>1</sup>	25 mm (1.0")	3 mm (0.125")	5 mm (0.2")
MAXIMUM	-	38 mm (1.5")	-	-

	DISPLACEMENT		
	Standard Legend Switch	Membrane/Tactile Legend Switch	
		Dome snap-action contact	Conductive membrane contact
MINIMUM	3 mm (0.125")	7 mm (0.03")	5 mm (0.2")
MAXIMUM	6 mm (0.25")	1 mm (0.04")	1 mm (0.04")

	RESISTANCE		
	Standard Legend Switch	Membrane/Tactile Legend Switch	
		Dome snap-action contact	Conductive membrane contact
MINIMUM	2.8 N (10 oz) <sup>4</sup>	1.5 N (5 oz)	2.0 N (7 oz)
MAXIMUM	16.7 N (60 oz)	2.5 N (9 oz)	3.0 N (11 oz)

<sup>1</sup>15 mm (0.65") where switch is not depressed below the panel.

<sup>2</sup>Bw also refers to switch separation.

<sup>3</sup>5 mm (0.2") for positive switches.

<sup>4</sup>5.6 N (20 oz) for use in moving vehicles.

## Legend switch

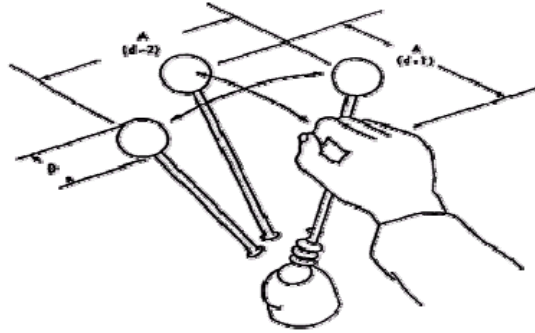

	DIAMETER		RESISTANCE			
	D		(d-1)		(d-2)	
	Finger Grasp	Hand Grasp	One Hand	Two Hands	One Hand	Two Hands
Minimum	13 mm (0.5 in.)	38 mm (1.5 in.)	9 N (2 lb)	9 N (2 lb)	9 N (2 lb)	9 N (2 lb)
Maximum	38 mm (1.5 in.)	75 mm (3 in.)	135 N (30 lb)	220 N (50 lb)	90 N (20 lb)	135 N (30 lb)
	DISPLACEMENT		SEPARATION			
	A		One Hand Random		Two Hands Simultaneously	
	Forward (d-1)	Lateral (d-2)				
Minimum	-	-	50 mm (2 in.)		75 mm (3 in.)	
Preferred			100 mm (4 in.)		125 mm (5 in.)	
Maximum	360 mm (14 in.)	970 mm (38 in.)				

## Levers

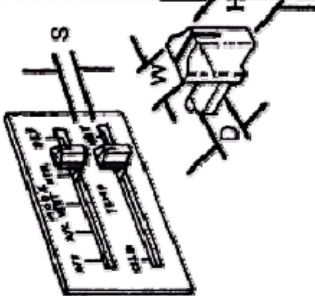
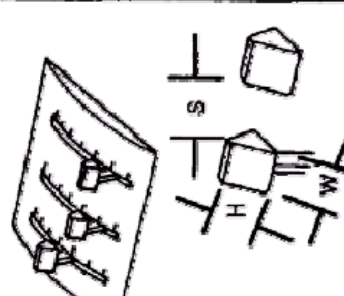
DESIGN GUIDELINES		DISPLACEMENT		SEPARATION	
CONFIGURATION EXAMPLE	APPLICATION GUIDELINES	DIMENSIONS			
	<p>Slide-levers may be used for low-force, continuous adjustment or gross-mode selection (do not use for precise setting).</p> <p>Handles should be "tab-shaped", with long dimension perpendicular to motion axis (to serve as a pointer).</p>	<p>D - Min = 13 mm (19 mm with gloves)</p>	<p>W - Min = 6.5 mm</p>	<p>H - Min = 16 mm</p>	<p>S - Min = 19 mm (23 mm with gloves)</p>
	<p>Banked, slide-lever assemblies may be used for electrically- and/or mechanically-connected selector or adjustment functions to provide rapid visual check of related settings.</p> <p>Note: Resistance for above control types should be:            MIN - 2.8N            Max - 110N</p>	<p>Same as above</p>	<p>Same as above</p>	<p>Same as above</p>	<p>Same as above</p>

Lever controls

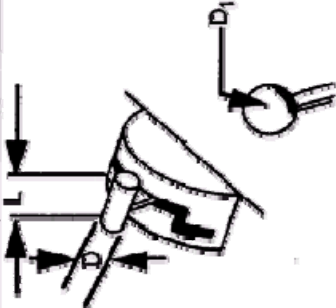
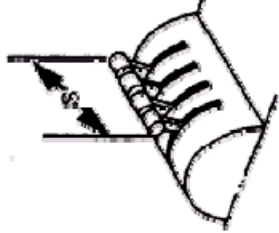
DESIGN GUIDELINES			
CONFIGURATION EXAMPLE	APPLICATION GUIDELINES	DIMENSIONS	DISPLACEMENT SEPARATION
	<p>Throttle levers: Handgrip may be either cylindrical or spherical.</p>	<p>D - Min = 19 mm            Max = 28 mm</p> <p><math>D_1 = 38 \pm 6</math> mm</p>	<p>Finger clearance all sides, min = 50 mm</p>
	<p>Multi-engine throttle assembly.</p> <p>Note: When thrust reverse is incorporated, the design should include a separate manipulative motion (lift + aft lever movement).</p>		<p>S - Typical 130 mm, not to exceed 125 mm</p>

Lever controls (continued)

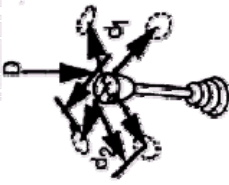
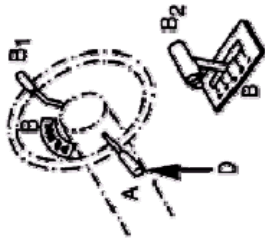
DESIGN GUIDELINES		DISPLACEMENT SEPARATION	
CONFIGURATION EXAMPLE	APPLICATION GUIDELINES	DIMENSIONS	
	<p>Gear-shift lever:</p> <p>Manual transmission: Locate for right-hand operation. Resistance: approximately 9 - 13 N</p>	<p>D - Knob diameter = 32 mm</p>	<p><math>d_1</math> and <math>d_2</math> between discrete positions = Min = 125 mm, Max total = 200 mm</p>
	<p>Automatic transmission: (<math>B_1</math> preferred; <math>B_2</math> acceptable). Detented positions required*</p> <p>A. Other functions:</p> <ol style="list-style-type: none"> <li>1. Turn signal - rotate about column; CW = right turn, CCW = left turn.</li> <li>2. Headlight dimming; lever moves toward bottom of column for "dim".</li> </ol> <p>B. Letters should illuminate to indicate position of lever.</p> <p>Resistance: Approximately 4.5 - 45 N</p> <p>* It should be impossible to leave gear lever between positions. Separate motion required to position lever in reverse (lift or press thumb button).</p>	<p>D - Handle diameter 19 - 32 mm if cylindrical, 25 - 32 mm if spherical</p>	<p>Finger clearance between levers and wheel rim - Min = 50 mm</p> <p>Gear shift - Min between positions = 25 mm for <math>B_1</math>; 38 mm for <math>B_2</math></p> <p>25 - 50 mm between detents recommended</p>

Lever controls (continued)

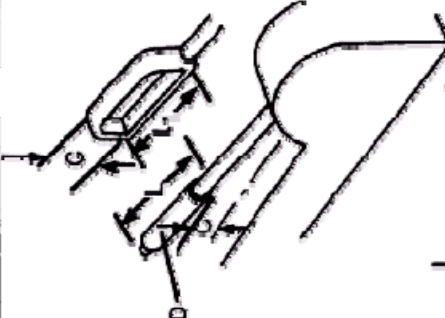
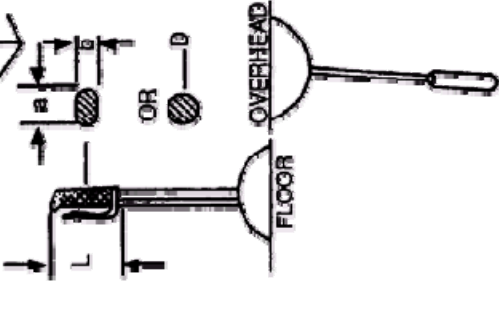
DESIGN GUIDELINES				
CONFIGURATION EXAMPLE	APPLICATION GUIDELINES	DIMENSIONS	DISPLACEMENT	SEPARATION
	<p>Hand brake, with thumb-button release</p> <p><math>l_1</math> - Loop handle acceptable.</p>	<p>D - Diameter = 25 - 32 mm</p> <p>L - Length Min = 100 mm</p> <p>C - Clearance Min = 50 mm</p>	<p>Nominal = 100 - 125 mm</p>	<p>Min = 65 mm All sides of handle</p>
	<p>High-force levers: Center of handle should be approximately 230 - 255 mm laterally from operator centerline, at elbow level. Provide clip-type release where applicable.</p> <p>Round or oval-shaped handle should be used.</p> <p>Max resistance approximately 187 N</p>	<p>L - Length Min = 100 mm</p> <p>Max a x b = 38 x 95 mm</p> <p>D = 38 - 45 mm with clip lever. Max fore-aft span should not exceed 75 mm.</p>	<p>Max for seated operator = 355 mm</p>	<p>Min clearance should be 50 mm in front, 75 mm either side</p>

Lever controls (continued)

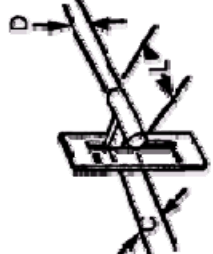
DESIGN GUIDELINES			
APPLICATION GUIDELINES	DIMENSIONS		DISPLACEMENT
	SEPARATION	DISPLACEMENT	
 <p>SPRING-LOADED PRESS</p> <p>Two-position, spring-return to "off" tab-lever. Use only in up-down orientation. Resistance approximately 4.5 - 27 N</p>	<p>W - Min = 25 mm</p>	<p>Displacement = 25 - 75 mm</p>	<p>Min separation between ends of handles = 19 mm (25 mm with gloves); min clearance behind handle</p>
	<p>D - Min = 19 mm</p>	<p>L - Min = 50 mm</p>	
 <p>Heavy-duty lever device. Handles should permit use of at least three fingers. Use only in up-down orientation.</p> <p>Resistance: approximately 4.5 - 25 N</p>	<p>C - Min clearance = 32 mm, 38 mm with gloves</p>	<p>Min = 50 mm</p>	<p>Min separation between ends of handles = 19 mm (25 mm with gloves); min clearance behind handle</p>
	<p>D - Min = 16 mm</p>	<p>L - Min = 65 mm</p>	

Lever controls (continued)



	DIMENSIONS			BUTTON CHARACTERISTICS	
	Width	Length	Height	Resistance	Displacement
MINIMUM	40 mm (1.6")	70 mm (2.8")	25 mm (1.0")	0.5 N (1.8 oz)	5 mm (0.02 ")
MAXIMUM	70 mm (2.8")	120 mm (4.7")	40 mm (1.6")	1.5 N (5.4 oz)	6 mm (0.24")

## Mouse

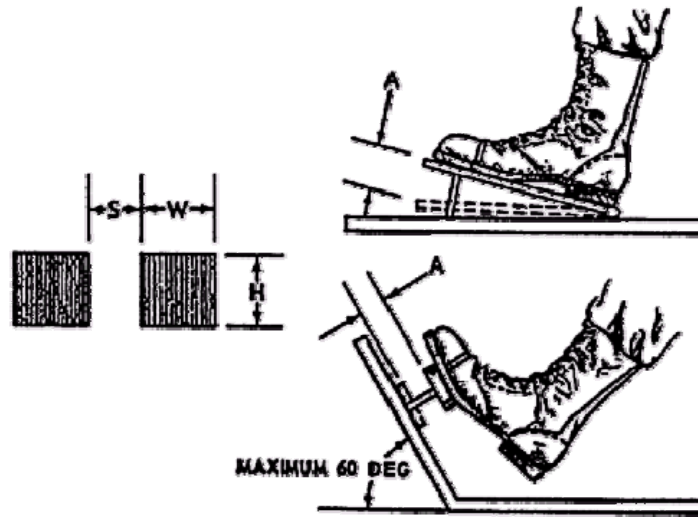

	DIMENSIONS		DISPLACEMENT				
	H Height	W Width	Normal Operation	A		Total Leg Movement	
Minimum	25 mm (1 in.)	75 mm (3 in.)	13 mm (0.5 in.)	Heavy Boots	25 mm (1 in.)	25 mm (1 in.)	25 mm (1 in.)
Maximum			65 mm (2.5 in.)	65 mm (2.5 in.)	65 mm (2.5 in.)	65 mm (2.5 in.)	180 mm (7 in.)
RESISTANCE							
	Foot Not Resting on Pedal		Foot Resting On Pedal	Ankle Flexion Only		Total Leg Movement	
Minimum	18 N (4 lb)		45 N (10 lb)	-		45 N (10 lb)	
Maximum	90 N (20 lb)		90 N (20 lb)	45 N (10 lb)		800 N (180 lb)	
SEPARATION							
	S						
	One Foot Random			One Foot Sequential			
Minimum	100 mm (4 in.)			50 mm (2 in.)			
Preferred	150 mm (6 in.)			100 mm (4 in.)			

## Pedals

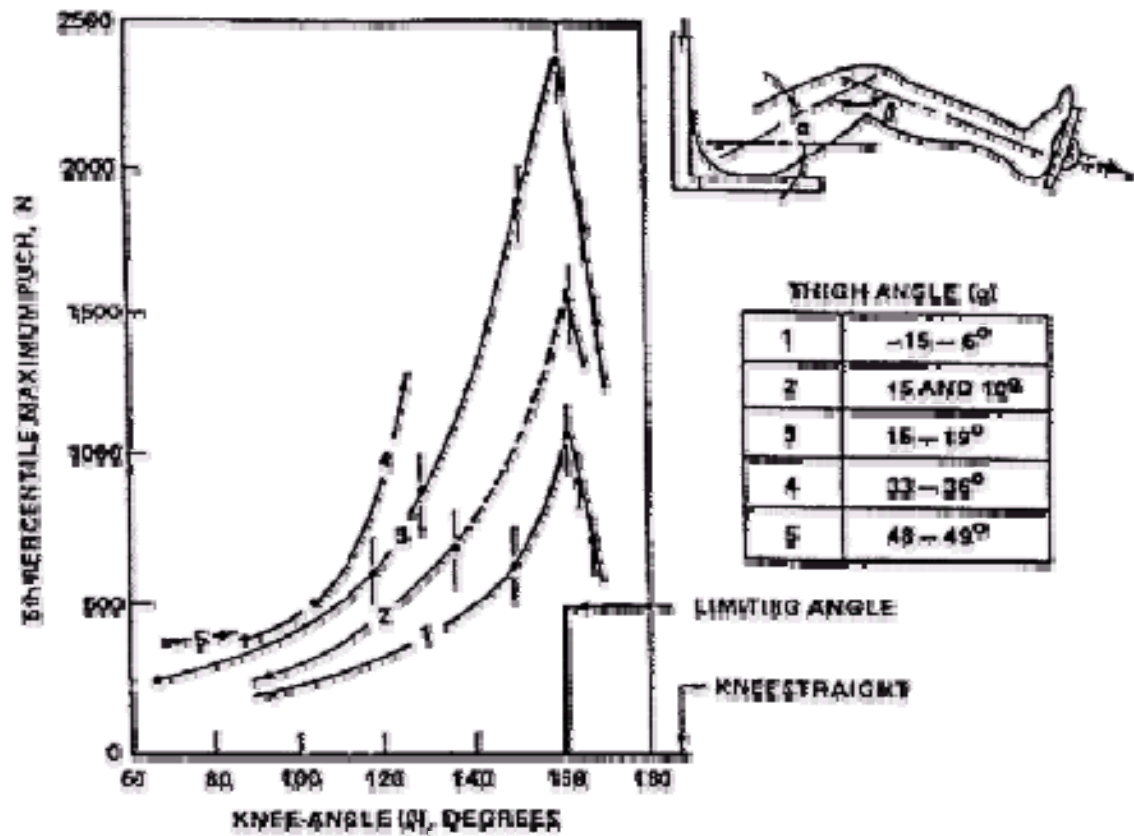

Leg strength at various knee and thigh angles

Switch State Feedback Options									
Function	Switch Action	Switch Configuration	Depressed Switchcap	Integral Lamp(s)	Integral Legend(s)	Adjacent Lamp(s)	Adjacent Legend(s)	Other Display Reflecting Switch Action	
Send short discrete signal to initiate or terminate some other function.	Momentary contact	Single button	Momentary only	Momentary only	Momentary only	Momentary only	Momentary only	Sufficient	
Send short signal of controllable duration.	Momentary contact	Single button	Momentary only	Momentary only	Momentary only	Momentary only	Momentary only	Sufficient	
Choose between two mutually exclusive states	Alternate action, latching	Two-button interlocked or Single-button	If mechanically latched	C	Sufficient	C	Sufficient	C	
Step through three or more switch states.	Stepping, latching	Single button with legend matrix	If mechanically latched	C	Sufficient	C	Sufficient	C	
Independently choose one out of three or more mutually exclusive states.	Latching and interlocked	Array of buttons	(No)	(No)	Sufficient (if multiple legend)	C	Sufficient	C	
Independently choose two or more out of a set of control functions each having two states.	Alternate action, latching	Array of buttons	If mechanically latched	C	Sufficient	C	Sufficient	C	

**NOTES:**

1. The feedback referred to pertains only to knowledge of switch state, not system state (which may impose additional feedback requirements).
2. A feedback option designated "sufficient" means that, properly instrumented it can provide all the information the operator needs concerning switch state; other methods showing annotation or C (contributing) need to be used in combination to provide adequate feedback.

Representative push button applications

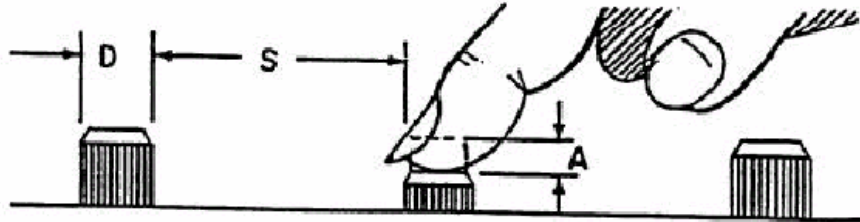

	DIMENSIONS (Diameter, D)						RESISTANCE		
	Fingertip		Thumb		Palm		Single Finger	Different fingers <sup>1</sup>	Thumb/Palm
	Bare hand	Gloved hand	Bare hand	Gloved hand	Bare hand	Gloved hand			
MIN	10 mm (0.4")	19 mm (0.75")	19 mm (0.75")	25 mm (1.0")	40 mm (1.6")	50 mm (2.0")	2.8 N 10 oz	1.4 N (5 oz)	2.8 N (10 oz)
MAX	25 mm (1.0")	—	25 mm (1.0")	—	70 mm (2.8")	—	11.0 N (40 oz)	5.6 N (20 oz)	23.0 N (80 oz)

	DISPLACEMENT (A)	
	Fingertip	Thumb or Palm
MIN	2 mm (0.08")	3 mm (0.12")
MAX	6 mm (0.25")	38 mm (1.5")

	SEPARATION (S)				
	Single Finger		Single Finger Sequential	Different Fingers	Thumb or Palm
	Bare	Gloved			
MIN	13 mm (0.5")	25 mm (1.0")	6 mm (0.25")	6 mm (0.25")	25 mm (1.0")
PREF	50 mm (2.0")	—	13 mm (0.5")	13 mm (0.5")	150 mm (6.0")

<sup>1</sup> Actuated at same time

NOTE: Where gloved hand criteria are not provided, minima should be suitably adjusted.

## Push buttons

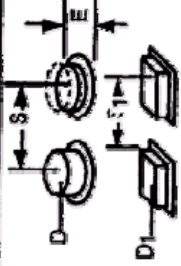
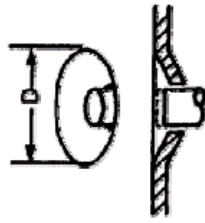
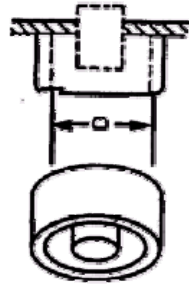
DESIGN GUIDELINES			
APPLICATION GUIDELINES	DIMENSIONS	DISPLACEMENT	SEPARATION
 <p>Panel-mounted push buttons: Single-finger, one button at a time. Non-legend or buttons that require only a single number on the front surface may be round, square, or rectangular.</p>	<p>D - Min diameter or dimension (T<sub>1</sub>) - 10 mm*</p> <p>D - Max = 19 mm; Min = 13 mm</p>	<p>E - Excursion, preferred min = 3.2 mm; preferred max = 6.5 mm. Add 13 mm for gloves**</p>	<p>S - Min = 19 mm (25 mm with gloves)</p> <p>S<sub>1</sub> - Min = 13 mm</p>
<p>A concave surface may be used to aid finger-centering (non-glove operation only).</p>	<p>D - Min well opening = 19 mm; 32 mm with gloves</p>		
<p>Recessed button to minimize inadvertent operation. Tapered "well" guides finger.</p> 			
<p>Prevent inadvertent operation of critical switch, either with guard ring or panel well.</p> 	<p>D - Same as above</p>		

\*For miniaturized applications, diameters as small as 3.2 mm may be used providing they accommodate all other relevant requirements, e.g., use of hardware, need for ruggedness.

\*\*Depressed buttons should remain exposed by at least 2.5 mm. Switches with no motion, e.g., thermal, may be used providing they accommodate all other relevant requirements.

## Push button switches

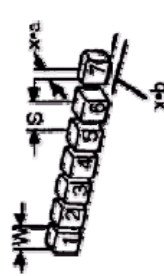
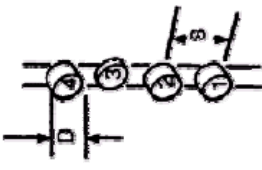

DESIGN GUIDELINES		DISPLACEMENT		SEPARATION	
APPLICATION GUIDELINES		DIMENSIONS			
	<p>Ganged push button assembly:</p> <p>Square, rectangular, or round shapes are acceptable. Repression of any button should cause any previously depressed button to return to deactivated position.</p>	<p>W or D - Min = 10 mm (13 mm for gloves)</p>	<p>x'a - Min exposure when depressed = 3.2 mm</p> <p>x'b - Min depression to actuate = 3.2 mm (preferred = 5 mm)</p> <p>Max displacement should not exceed 13 mm</p>		<p>S - Center-to-center spacing, Min = 19 mm (25 mm for gloves)</p>
	<p>Numbered buttons should progress as illustrated.</p>				

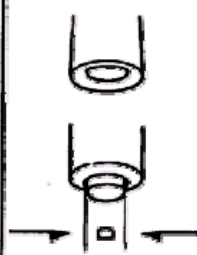
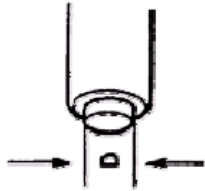
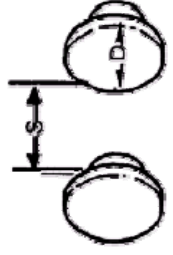
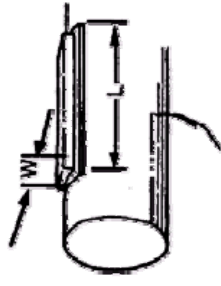
Push button switches (continued)

DESIGN GUIDELINES		DIMENSIONS		DISPLACEMENT		SEPARATION	
APPLICATION GUIDELINES							
 <p>Handle, end-mounted, push button switch: Index finger-operated. Recess to preclude inadvertent operation.</p>		D - Min = 10 mm		Same as above			
 <p>Thumb-operated</p>		D - Min = 13 mm		Same as above			
 <p>Alternate finger or heel of the hand operation. Convex surface desirable</p>		D - Min = 25 mm		Same as above		5 - Min for palm operation = 75 mm	
 <p>Grip handle switch Alternate multi-finger or palm operation</p>		W - Min = 5.5 mm L - Preferred min = 25 mm		Same as above			

Push button switches (continued)

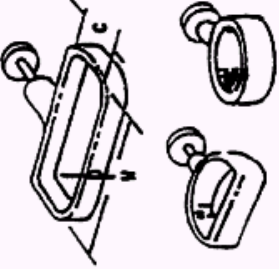

CONFIGURATION EXAMPLE	APPLICATION CRITERIA	DESIGN CRITERIA			
		DIMENSIONS		DISPLACEMENT	SEPARATION
	<p>PUSH-PULL CONTROL, LOW RESISTANCE, FOR TWO-POSITION, MECHANICAL AND/OR ELECTRICAL SYSTEMS.</p> <p>ALTERNATE THREE POSITION PLUS ROTARY FUNCTION ACCEPTANCE FOR APPLICATION SUCH AS VEHICLE HEADLIGHT PLUS PARKING LIGHTS, PANEL AND DOME LIGHTS PROVIDE SERRATED RIM.</p>	<p>D, MIN DIAM: 19 mm (0.75")</p> <p>C, MIN CLEARANCE: 25 mm (1") Add 13 mm (0.5") for gloved hand</p>	<p>25 ±13 mm (1 ±0.5")</p> <p>MIN BETWEEN PULL POSNS: 13 mm (0.5")</p>	<p>S, MIN SPACE BETWEEN: 35 mm (1.5") Add 13 mm (0.5") for gloved hand</p>	
	<p>ALTERNATE HANDLE; MINIATURE ELECTRICAL PANEL SWITCH ONLY. AVOID GLOVE USE APPLICATION.</p>	<p>N/A</p>	<p>L, MIN LGTH: 19 mm (0.75")</p>	<p>S, MIN SPACE BETWEEN: 23 mm (1")</p>	
	<p>HIGH-FORCE PUSH-PULL, FOR TWO-POSITION MECHANICAL SYSTEM ONLY.</p>	<p>W, MIN WIDTH: 100 mm (4")</p> <p>D, DEPTH: 16-38 mm (0.625-1.5")</p>	<p>C, MIN CLEARANCE: 38 mm (1.5") Add 6 mm (0.25") for gloved hand</p>	<p>MINIMUM: 25 mm (1")</p> <p>PREFERRED: 50 mm (2")</p>	
	<p>SAME AS ABOVE. PREFERRED WHERE POSSIBLE GARMENT OR CABLE-SNAG POSSIBILITY EXISTS.</p> <p>NOTE: 1 &amp; 2 FINGER PULLS ALSO ACCEPTABLE FOR LESS THAN 18 N (4lb) APPLICATIONS.</p>	<p>W, MIN WIDTH: 100 mm (4") Add 25 mm (1") for gloves</p> <p>D, DEPTH: 16-32 mm (0.625-1.25")</p>	<p>C, MIN CLEARANCE: 32 mm (1.25")</p>	<p>S, MIN SPACE BETWEEN: 13 mm (0.5")</p> <p>MINIMUM: 25 mm (1")</p> <p>PREFERRED: 50 mm (2")</p>	

## Push-pull controls

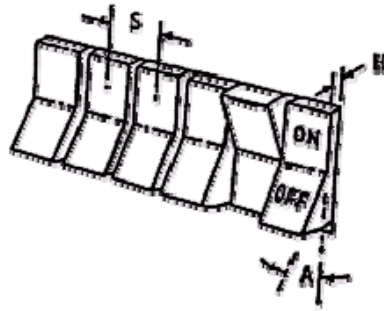

STANDARD ROCKER SWITCH; USE AS ALTERNATE TWO-POSN TOGGLE SWITCH TO PROVIDE LABELING SURFACE, EASE OF COLOR CODING, SWITCH ILLUMINATION.

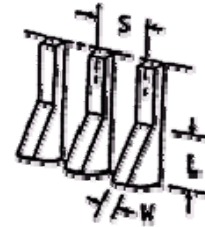

NARROW WIDTH, ESPECIALLY DESIRABLE FOR TACTILE DEFINITION WITH GLOVES.

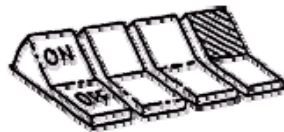

ALTERNATE (CONTRAST) COLOR FOR ON VERSUS OFF TO PROVIDE CONSPICUOUS CUE OF SWITCH POSITION. ILLUMINATED "ON" DESIRABLE AS SECOND FEEDBACK CUE.

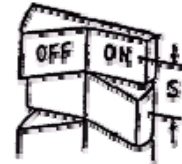

	DIMENSIONS		RESISTANCE
	W, WIDTH	L, LENGTH	
MINIMUM	6 mm (0.25")	13 mm (0.5")	2.8 N (10 oz.)
MAXIMUM			11 N (40 oz.)

	DISPLACEMENT		SEPARATION (Center-to-Center)	
	H, DEPRESSED	A, ANGLE	S (Bare Hand)	S (Gloved Hand)
MINIMUM	3 mm (0.125")	530 mrad (30°)	19 mm (0.75")	32 mm (1.125")

## Rocker switches

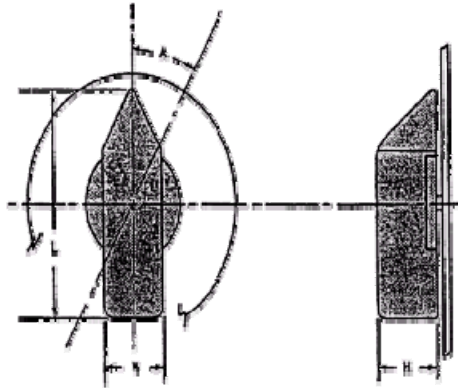



	DIMENSIONS			RESISTANCE
	L Length	W Width	H Depth	
Minimum	25 mm (1 in.)		16 mm (0.625 in.)	115 mN · m (1 in. -lb)
Maximum	100 mm (4 in.)	25 mm (1 in.)	75 mm (3 in.)	680 mN · m (6 in. -lb)
	DISPLACEMENT		SEPARATION	
	A		One-Hand Random	Two-Handed Operation
	•	••		
Minimum	262 mrad (15°)	525 mrad (30°)	25 mm (1 in.)	75 mm (3 in.)
Maximum	700 mrad (40°)	1570 mrad (90°)	•	•
Preferred	•	•	50 mm (2 in.)	125 mm (5 in.)

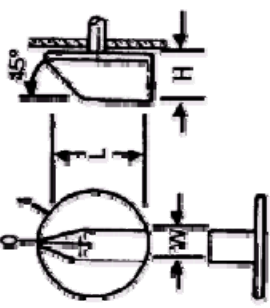

\* For facilitating performance

\*\* When special engineering requirements demand large separation or when tactually (“blind”) positioned controls are required.

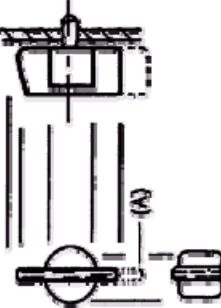

## Rotary selector switch

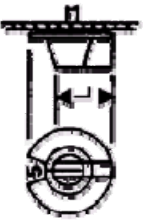
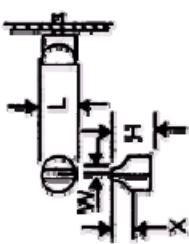
DESIGN GUIDELINES		SEPARATION	
APPLICATION GUIDELINES		DISPLACEMENT	
DIMENSIONS		SEPARATION	
 <p>Preferred for accurate identification of knob position by feel. For use on electronic, aircraft, and automotive control panels where high force switches are not required. Skirt optional.</p> <p>Switch resistance (approximate) max:  <math>L = 38 \text{ mm}</math>: 0.11 N·m  <math>L = 56 \text{ mm}</math>: 0.34 N·m  <math>L = 149 \text{ mm}</math>: 0.68 N·m</p> <p>Above guidelines acceptable as long as knob positions remain in upper 160°.</p>  <p>(A) Extended tail helpful for higher torque. Use only when pointer marking clearly visible.</p>	<p><math>L = 38 \text{ mm}</math> to 100 mm; if gloves are worn, add 13 mm</p> <p><math>W = 13 \text{ mm}</math> to 25 mm</p> <p><math>H = 14 \text{ mm}</math> to 75 mm</p> <p>min = 15°; minimum for blind position identification = 30°</p>	<p>See figure 16.</p> <p>For simultaneous operation of adjacent knobs (two hands), add 25 mm (38 mm for gloves).</p>	<p>See above</p> <p>See above</p> <p>See above</p> <p>See above</p>
 <p>Preferred alternative to (A) above where high torque is not required.</p>	<p>See above</p>	<p>See above</p>	<p>See above</p>

Rotary selector controls

DESIGN GUIDELINES		DIMENSIONS		DISPLACEMENT		SEPARATION	
APPLICATION GUIDELINES							
 <p>Preferred alternative to (A) above when only gross setting is required (major numbered positions) and where high torque is not required.</p>	<p>L - Min = 25 mm; other dimensions same as (A)</p>	See above	See above	See above	See above	See above	
 <p>Acceptable only for applications where panel space is limited and gloves not worn; switch resistance less than .012 N-m</p> <p>For heavy duty, high torque switches:</p>	<p>L - Min = 19 mm</p>	<p>K - Min = 6.5 mm</p>	<p>X - Min = 13 mm</p>	See above	See above	25 mm	
 <p>Preferred</p>	<p>Ø = 16 mm to 25 mm</p>	<p>L - Min = 109 mm</p>	<p>H - Min = 32 mm</p>	Min = 10°	See above	End to end handle separation = 75 mm	
 <p>Acceptable alternative</p>	<p>Ø = See above</p>	<p>L<sub>1</sub> - Min = 50 mm</p>	H = See above	See above	See above	See above	

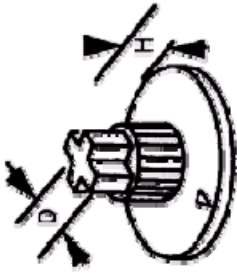
Rotary selector controls (continued)

DESIGN GUIDELINES			
APPLICATION GUIDELINES	DIMENSIONS	DISPLACEMENT	SEPARATION
 <p>Tactile control identification, preferred method for rotary controls</p>	<p>D - Min = 18 mm</p> <p>H - Min = 3.2 mm, max = 19 mm</p>		
 <p>Tactile cap for rotary selector knob</p>	<p>Same as above</p>	<p>Same as above</p>	

Rotary selector controls (continued)

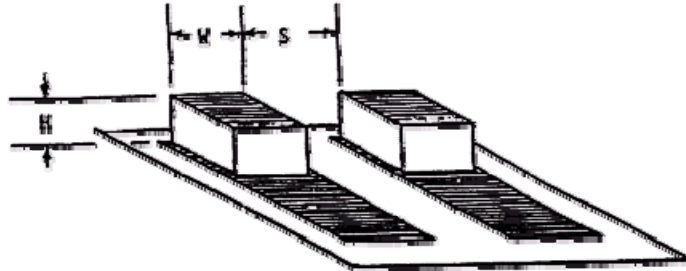

	DIMENSIONS		RESISTANCE		
	H ACTUATOR HEIGHT		W ACTUATOR WIDTH	SMALL SWITCH	LARGE SWITCH
	*	**			
MINIMUM	6 mm (0.25")	13 mm (0.5")	6 mm (0.25")	2.8 N (10 oz.)	2.8 N (10 oz.)
MAXIMUM	--	--	25 mm (1")	4.5 N (16 oz.)	11 N (40 oz.)

	SEPARATION, S		
	SINGLE FINGER OPERATION	SINGLE FINGER SEQUENTIAL OPERATION	SIMULTANEOUS OPERATION BY DIFFERENT FINGERS
MINIMUM	19 mm (0.75")	13 mm (0.5")	16 mm (0.625")
OPTIMUM	50 mm (2")	25 mm (1")	19mm (0.75")

\*Use by bare finger.

\*\* Use with heavy handwear.

## Slide switches

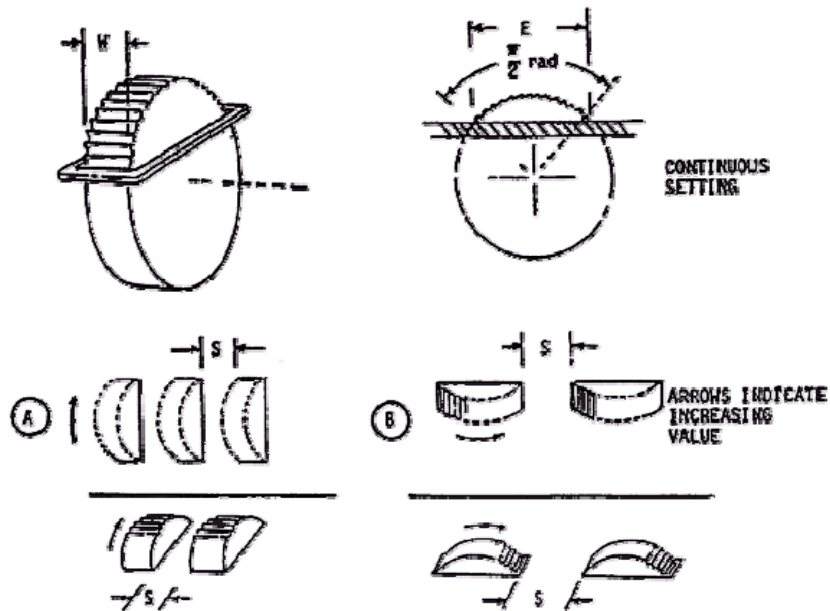

	E RIM EXPOSURE	W WIDTH	S		RESISTANCE
			Ⓐ	Ⓑ	
MINIMUM	25 mm * (1")	3 mm * (0.125")	25 mm (1") Add 13 mm (1/2") for gloves	50 mm (2") Add 25 mm (1") for gloves	TO MINIMIZE EFFECTS OF INADVERTENT INPUT IF OPERATOR SUBJECT TO MOTION
MAXIMUM	100 mm (4")	23 mm (0.875")	N/A	N/A	3.3 N (12 oz.)

\* Preferred. Some miniature applications may require less.

## Thumbwheel, continuous adjustment



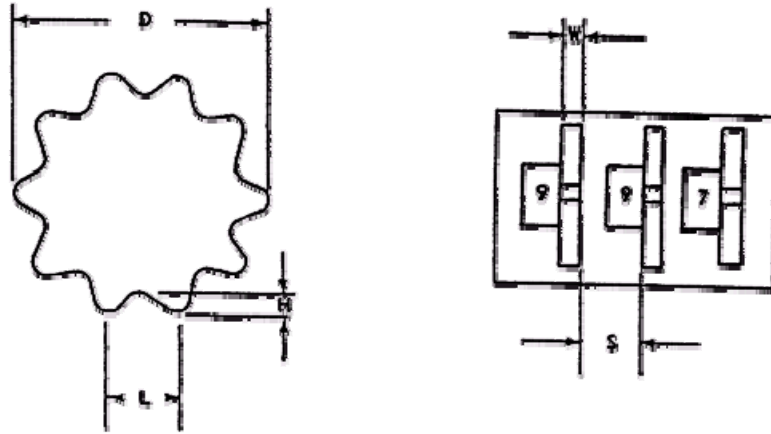





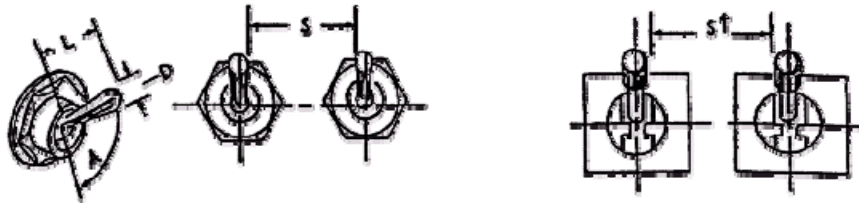

	D DIAMETER	L TROUGH DISTANCE	W WIDTH	H DEPTH	S SEPARATION	RESISTANCE
MINIMUM	29 mm (1.125 in)	11 mm (0.43 in)	3 mm (0.125 in)	3 mm (0.125 in)	10 mm (0.4 in)	1.7 N (6 oz)
MAXIMUM	75 mm (3 in)	19 mm (0.75 in)		6 mm (0.25 in)		5.6 N (20 oz)

Thumbwheel, discrete



	DIMENSIONS			RESISTANCE	
	L Arm Length		D Control Tip	Small Switch	Large Switch
	Use by bare finger	Use with heavy handwear			
Minimum	13 mm (0.5")	38 mm (1.5")	3 mm (0.125")	2.8 N (10 oz)	2.8 N (10 oz)
Maximum	50 mm (2.0")	50 mm (2.0")	25 mm (1.0")	4.5 N (16 oz)	11 N (40 oz)
	DISPLACEMENT BETWEEN POSITIONS				
	Two Position			Three Position	
	Minimum	30°			17°
	Maximum	80°			40°
	Preferred	---			25°
	SEPARATION, S				
	Single Finger Operation		Single Finger Sequential Operation	Simultaneous Operation by Different Fingers	
	Normal	Lever Lock Switch			
Minimum	19 mm (0.75")	25 mm (1.0")	13 mm (0.5")	16 mm (0.625")	
Optimum	50 mm (2.0")	50 mm (2.0")	25 mm (1.0")	19 mm (0.75")	

## Toggle switches

DESIGN GUIDELINES			DIMENSIONS		DISPLACEMENT	SEPARATION
APPLICATION GUIDELINES						
 <p>Miniature toggle switch: Limit use to indoor applications where limited panel space precludes standard size components.</p>	D - Diameter min = 3.3 mm	L - Length min = 13 mm				
 <p>Standard configuration: Use larger sizes for applications where gloved operation is likely.</p>	D - Diameter min = 4.5 mm max = 9.0 mm	L - Length min = 13 mm max = 50 mm				
 <p>Ball cap design applicable where firm grasp of toggle is needed because of vehicle or operator oscillation.</p>	D - Diameter min = 4.5 mm max = 9.8 mm (add 13 mm for sleeves)	Same as above				
 <p>Flat or applied tab handles provide improved visual position reference when operationally important.</p>			W - Handle width min = 4.5 mm			
 <p>Applied tab handle provides means for color coding.</p>				L - Length preferred = 16 mm min = 4.8 mm max = 19 mm		
 <p>Alternate to any standard size configuration above.</p>				Same as above		

Toggle switch controls

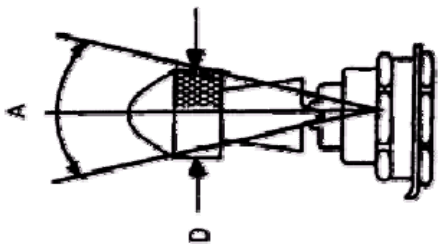
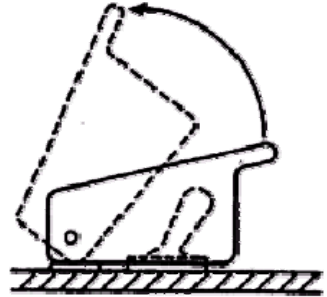
DESIGN GUIDELINES			
APPLICATION GUIDELINES	DIMENSIONS	DISPLACEMENT	SEPARATION
 <p>Typical two-step interlocking safety switch.</p>	<p>D - Diameter min = 10 mm</p>	<p>A - Angular displacement: Two positions min = 30°, max = 80°; three positions - min = 17°, max = 40°</p>	<p>Should not be closer than 50 mm to other control or structure.</p>
<p>Alternate cover guard switch. Cover easily color-coded. Not applicable for miniaturized toggles.</p> 			<p>May be horizontally spaced as close as 13 mm (25 mm for gloves).</p>

Toggle switch controls (continued)

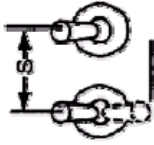
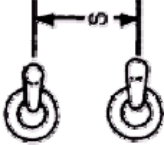
DESIGN GUIDELINES		APPLICATION GUIDELINES	DIMENSIONS	DISPLACEMENT	SEPARATION
	<p>Two-position switches only when visual recognition of switch position mandatory.</p>			D - Displacement angle Min = 30°	
				<p>Three-position switches.</p>	
	<p>Side-by-side arrangement vertical displacement.</p>				<p>S - Center-to-center spacing Min = 19 mm</p>
	<p>Vertical arrays</p>				<p>S - Min = 25 mm</p>

Toggle switch controls (continued)

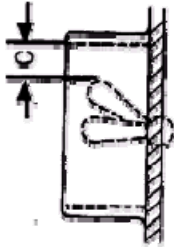
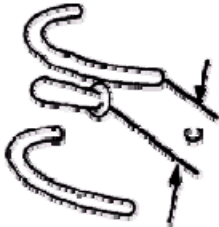
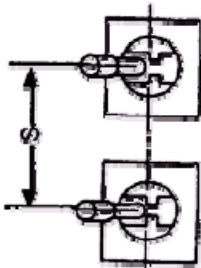
DESIGN GUIDELINES		DISPLACEMENT SEPARATION	
APPLICATION GUIDELINES		DIMENSIONS	
	<p>Guard switches where accidental displacement of a switch may be undesirable (not necessarily dangerous).</p>	<p>C - Tip - guard finger clearance MIN = 13 mm</p>	
	<p>Use two-motion safety switch when switch-use error could lead to dangerous consequence (pull to operate).</p>	<p>D - Min = 25 mm; 32 mm for gloves</p>	
			<p>S - Min = 25 mm (50 mm preferred); add 13 mm for gloves</p>

Toggle switch controls (continued)

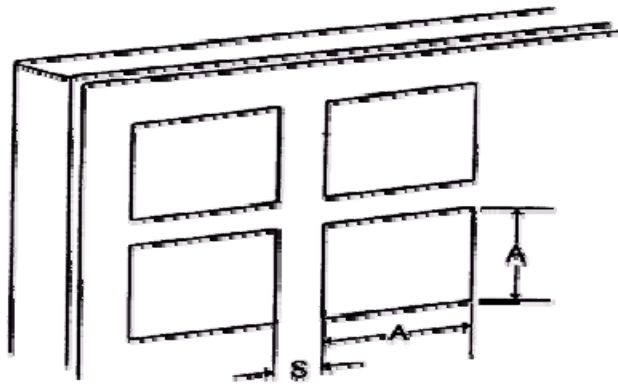

ALPHANUMERIC / NUMERIC KEYBOARDS			
	A (Actuation Area)	S (Separation) <sup>1</sup>	Resistance
MINIMUM	—	0	250 mN (0.9 oz)
PREFERRED	13 x 13 mm (0.5 x 0.5")	—	—
MAXIMUM	—	6 mm (0.25")	1.5 N (5.3 oz)

OTHER APPLICATIONS			
	A (Actuation Area)	S (Separation) <sup>1</sup>	Resistance
MINIMUM	16 x 16 mm (0.65 x 0.65")	3 mm (0.13 in)	250 mN (0.9 oz)
MAXIMUM	38 x 38 mm (1.5 x 1.5")	6 mm (0.25")	1.5 N (5.3 oz)

<sup>1</sup>For touch screens that use a “first contact” actuation strategy, separation between targets should be not less than 5 mm (0.2”). For touch screens that use a “last contact” strategy, separation between targets may be less than 5 mm (0.20”), but not less than 3 mm (0.12”) for applications other than alphanumeric/numeric keyboards.

## Touch screens

Type of Controller	Control Order Utilized	Acceptable Display Applications			
		XY Data Pickoff	Continuous Tracking	Free-Drawn Graphics	Setting Cross Hairs
Simultaneously-operated hand cranks	Position	Not Recommended	Not Recommended	Not Recommended	Good
Ball control	Position	Good	Fair	Poor	Good
Isometric joystick (Shift stick)	Position, Rate-Aided	Good	Good	Fair	Fair
Isotonic joystick (displacement stick)	Position, Rate-Aided	Good	Good	Good	Fair
Grid and stylus devices	Position	Good	Fair	Good	Good
Free-moving XY controller (mouse)	Position	Good	Not Recommended	Not Recommended	Fair
Light pen (augmented)	Position	Good	Fair	Good	Fair

Two-axis controllers for display applications

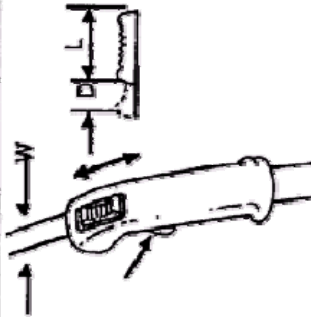
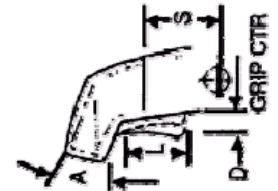
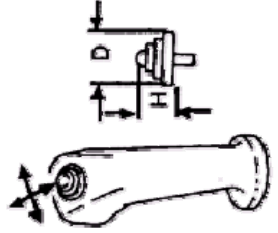

DESIGN GUIDELINES		DIMENSIONS		DISPLACEMENT	SEPARATION
APPLICATION GUIDELINES					
 <p>Thumb-actuated switch, two or three position, single axis. Typical application is supplemental on-off function coupled to primary control grip. Concave contact surface with serration desirable.</p>	<p>L - Switch length: Min = 16 mm</p> <p>W - Width: Min = 6.5 mm</p> <p>D - Min = 6.5 mm; Max = 19 mm</p>				N/A
 <p>Index finger operated trigger. Applications include hand weapons and joystick weapon firing control. Slight concave surface desirable.</p>	<p>L - Min = 25 mm</p> <p>A - Preferred angle between 30 and 45°</p> <p>S - Grip to trigger center spacing = 50 ± 6 mm</p>	<p>Same as above</p>			
 <p>Thumb-operated, two-dimensional switch, spring-centering. Typical application is trim control. Switch cap shown is typical.</p>	<p>D - Diameter = 19 ± 6 mm</p> <p>H = 19 ± 6 mm</p>				N/A

Grip switches

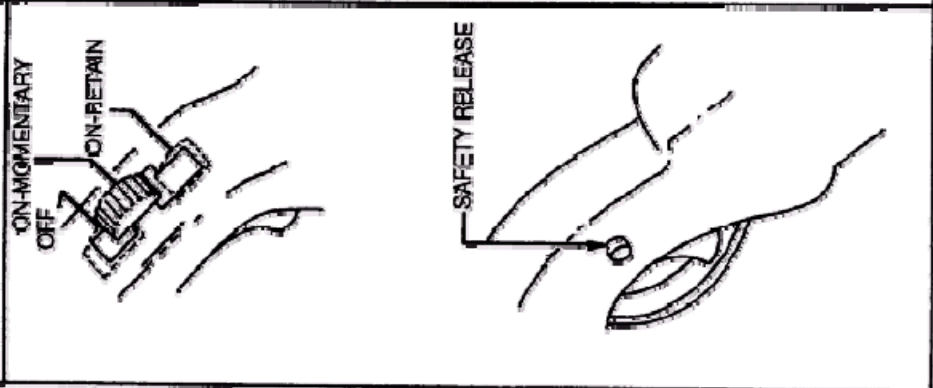
		DESIGN GUIDELINES			
		DIMENSIONS		DISPLACEMENT	SEPARATION
	<p><b>APPLICATION GUIDELINES</b></p>				
 <p>ON-MOMENTARY OFF ON-RETAIN</p> <p>SAFETY RELEASE</p>	<p>Active thumb-operated safety and trigger controls.</p> <p>Mechanical thumb switch guide (spring-loaded, momentary-to-off). Must have thumb switch in momentary or retain to actuate trigger.</p> <p>Momentary safety button. Must be held to actuate trigger.</p>				

Grip switches (continued)

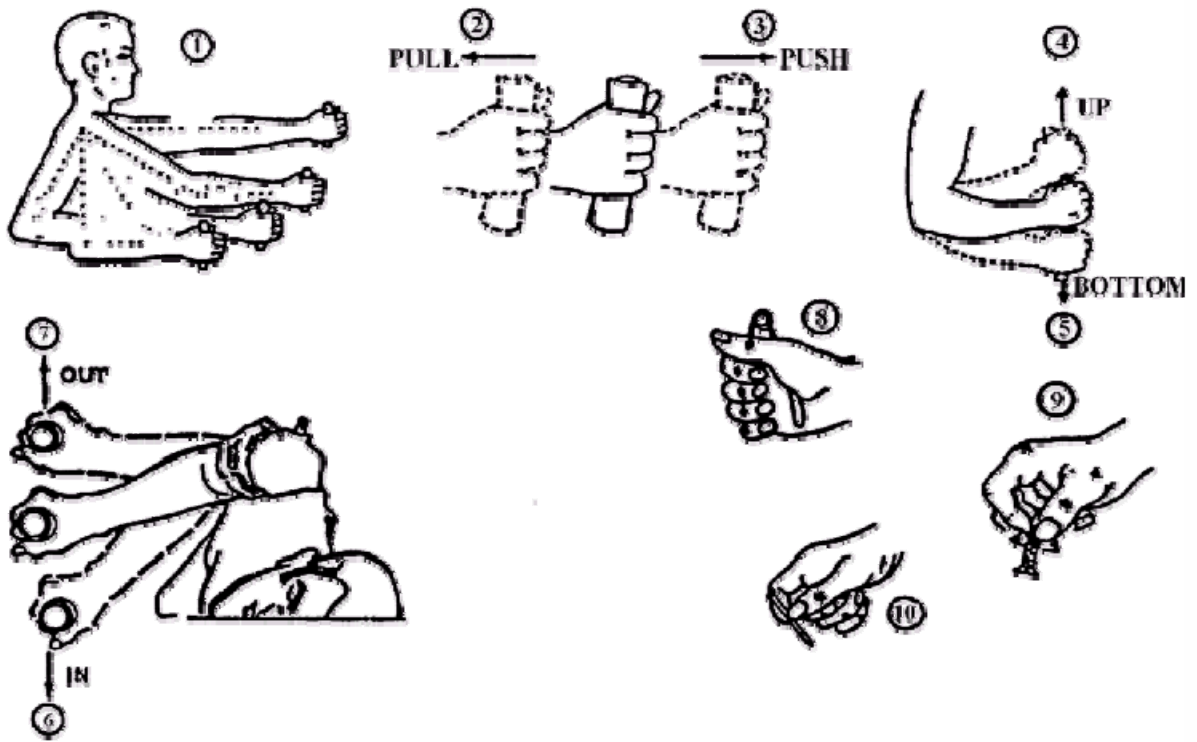

ARM STRENGTH (N)												
(1) DEGREE OF ELBOW FLEXION (deg)	(2) PULL		(3) PUSH		(4) UP		(5) DOWN		(6) IN		(7) OUT	
	L*	R*	L	R	L	R	L	R	L	R	L	R
180	222	231	187	222	40	62	58	76	58	89	36	62
150	187	249	133	187	67	80	80	89	67	89	36	67
120	151	187	116	160	76	107	93	116	89	98	45	67
90	142	165	98	160	76	89	93	116	71	80	45	71
60	116	107	98	151	67	89	80	89	76	89	53	76
HAND, AND THUMB-FINGER STRENGTH (N)												
	(8) HAND GRIP		(9) THUMB-FINGER GRIP (PALMER)				(10) THUMB-FINGER GRIP (TIPS)					
	L	R										
MOMENTARY HOLD	250		260				60		60			
SUSTAINED HOLD	145		155				35		35			

\*L = Left; R = Right

Arm, hand, and thumb-finger strength (5<sup>th</sup> percentile male)

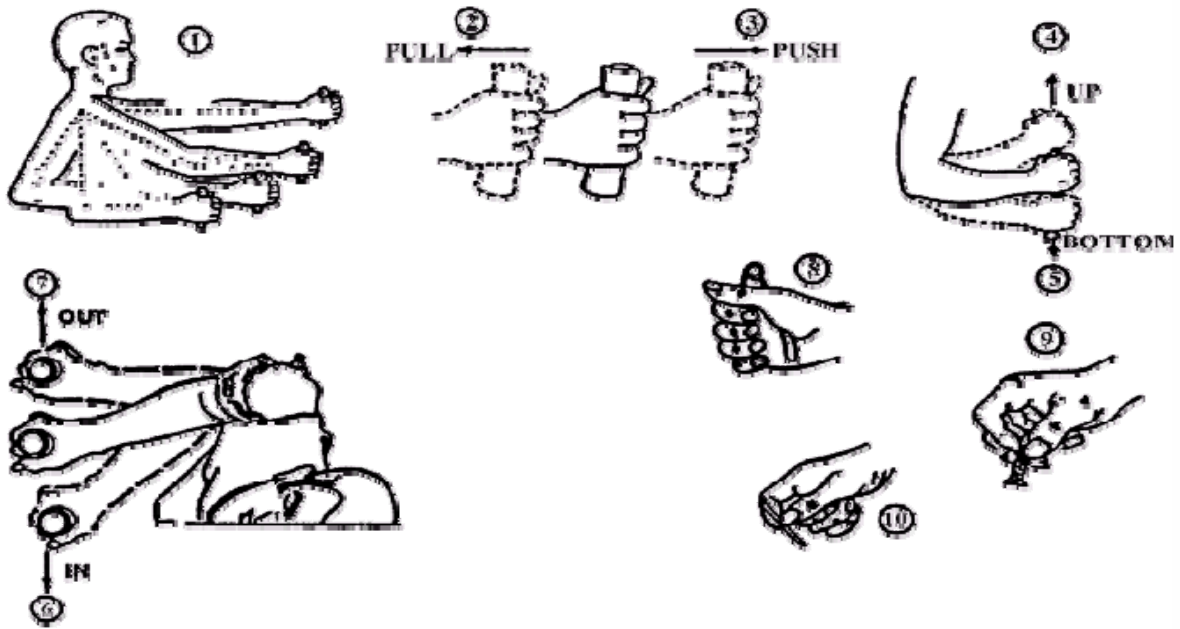

ARM STRENGTH (lb)												
(1) DEGREE OF ELBOW FLEXION (deg)	(2) PULL		(3) PUSH		(4) UP		(5) DOWN		(6) IN		(7) OUT	
	L	R*	L	R	L	R	L	R	L	R	L	R
180	50	52	42	50	9	14	13	17	13	20	8	14
150	42	56	30	42	15	18	18	20	15	20	8	15
120	34	42	26	36	17	24	21	26	20	22	10	15
90	32	37	22	36	17	20	21	26	16	18	10	16
60	26	24	22	34	15	20	18	20	17	20	12	17
HAND, AND THUMB-FINGER STRENGTH (lb)												
	(8) HAND GRIP		(9) THUMB-FINGER GRIP (PALMER)				(10) THUMB-FINGER GRIP (TIPS)					
	L	R										
MOMENTARY HOLD	56	59	13				13					
SUSTAINED HOLD	33	35	8				8					

\*L = LEFT; R = RIGHT

Arm, hand, and thumb-finger strength (5<sup>th</sup> percentile male) (continued)

MARKINGS	HEIGHT <sup>1</sup>	
	3.5 cd/m <sup>2</sup> (1 ft—L) OR BELOW	ABOVE 3.5 cd/m <sup>2</sup> (1 ft—L)
Critical markings with position variable (e.g., numerals on counters)	5—8 mm (0.20 —0.31 in)	3—5 mm (0.12—0.20 in)
Critical markings with position fixed (e.g., numerals on fixed scales, controls and switch markings, or emergency instructions)	4—8 mm 0.16 - 0.31 in)	2.5—5 mm (0.10 - 0.20 in)
Noncritical markings (e.g., identification labels, routine instructions, or markings required only for familiarization)	2.5—5 mm (0.10—0.20 in)	2.5—5 mm (0.10—0.20 in)

<sup>1</sup>Values assume a 710 mm (28 in.) viewing distance. For other distances, multiply the above values by D/710 mm (D/28 in.).

## Character height versus luminance

<b>Condition</b>	<b>Ratio of foreground to background</b>
Bright ambient illumination	> 7:1
Dark ambient illumination	3:1 to 5:1
To attract attention	> 7:1
To sharpen edges	> 7:1
Continuous reading	3:1 to 5:1
Camouflage images or smooth edges	< 3:1

Luminance contrast ratios for various conditions

<b>Pixels in upper case character height</b>	<b>Minimum stroke pixel count</b>	<b>Maximum stroke pixel count</b>
7 to 8	1	1
9 to 12	1	2
13 to 14	2	2
15 to 20	2	3
21 to 23	2	4

Stroke width for pixel-generated characters

<b>Pixels in upper case character height</b>	<b>Minimum width pixel count</b>	<b>Preferred width pixel count</b>	<b>Maximum width pixel count</b>
7	4	5	5
8	4	6	7
9	5	6	8
10	5	7	9
11	6	8	10
12	6	9	11
13	6	9	12
14	7	10	13
15 or 16	8	11	14

Height-width relationship for pixel-generated characters

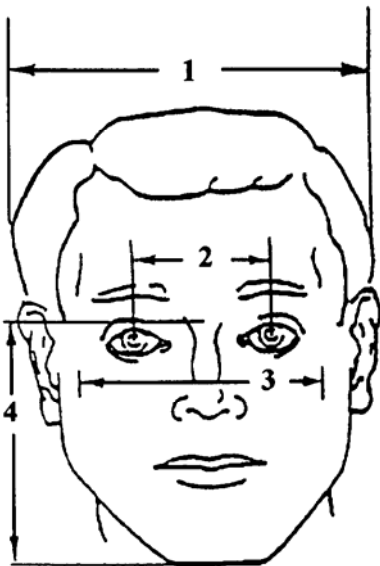

**1 Head breadth.** The maximum breadth of the head, usually above and behind the ears.

Sample		Percentiles					
		1st	5th	50th	95th	99th	
A	Men	cm (in)	13.9 (5.1)	14.3 (5.6)	15.2 (6.0)	16.11 (6.3)	6.5 (6.5)
B	Women	cm (in)	13.3 (5.2)	13.7 (5.4)	14.4 (5.7)	15.3 (6.0)	15.7 (6.1)

**2 Interpupillary breadth.** The distance between the centers of the pupils of the eyes (the eyes are looking straight ahead).

Sample		Percentiles					
		1st	5th	50th	95th	99th	
A	Men	cm (in)	5.7 (2.2)	5.9 (2.3)	6.5 (2.7)	7.1 (2.8)	7.4 (2.9)
B	Women	cm (in)	5.5 (2.2)	5.7 (2.2)	6.0 (2.4)	6.9 (2.7)	7.0 (2.8)

**3 Face breadth (bizygomatic).** The breadth of the face, measured across the most lateral projections of the cheek bones (zygomatic arches).

Sample		Percentiles					
		1st	5th	50th	95th	99th	
A	Men	cm (in)	12.8 (5.0)	13.2 (5.2)	14.0 (5.5)	15.0 (5.9)	15.4 (6.1)
B	Women	cm (in)	12.1 (4.8)	12.3 (4.8)	12.8 (5.1)	14.0 (5.5)	15.4 (5.7)

**4 Face length (menton-sellion).** The vertical distance from the tip of the chin (menton) to the deepest point of the nasal root depression between the eyes (sellion).

Sample		Percentiles					
		1st	5th	50th	95th	99th	
A	Men	cm (in)	10.8 (4.3)	11.2 (4.4)	12.2 (4.8)	13.3 (5.2)	13.7 (5.4)
B	Women	cm (in)	10.1 (3.4)	10.4 (4.1)	11.3 (4.5)	12.4 (4.9)	12.9 (5.1)

## Static human physical characteristics - head



- 5 **Biocular breadth.** The distance from the outer corners of the eyes (right and left ectocanthi).

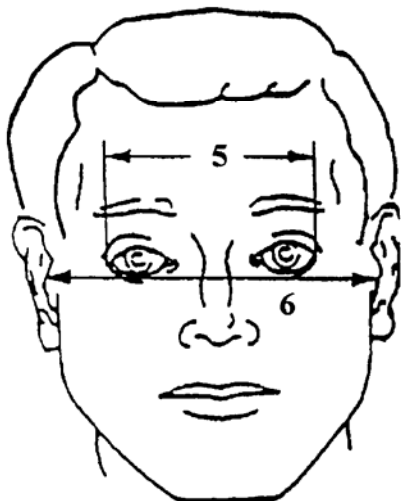

Sample			Percentiles				
			1st	5th	50th	95th	99th
A	Men	cm (in)	11.0 (4.3)	11.3 (4.5)	12.2 (4.8)	13.1 (5.2)	13.6 (5.4)
B	Women	cm (in)	10.8 (4.3)	11.1 (4.4)	11.6 (4.3)	12.9 (5.1)	13.3 (5.3)

- 6 **Bitragion breadth.** The breadth of the head from the right tragon to the left. (Tragon is the cartilaginous notch at the front of the ear).

Sample			Percentiles				
			1st	5th	50th	95th	99th
A	Men	cm (in)	13.1 (5.2)	13.5 (5.3)	14.5 (5.7)	15.5 (6.1)	15.9 (6.3)
B	Women	cm (in)	12.5 (4.3)	12.8 (5.4)	13.3 (5.4)	14.3 (5.7)	15.0 (5.9)

- 7 **Glabella to back of head.** The horizontal distance from the most anterior point of the forehead between the brow-ridges (glabella) to the back of the head, measured with a headboard.

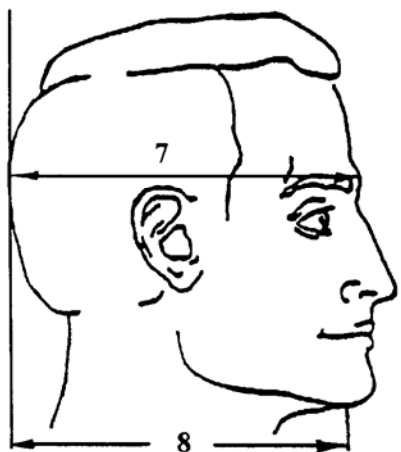

Sample			Percentiles				
			1st	5th	50th	95th	99th
A	Men	cm (in)	18.3 (7.2)	18.8 (7.4)	20.0 (7.9)	21.1 (8.3)	21.7 (8.5)
B	Women	cm (in)	17.5 (6.9)	18.0 (7.1)	19.1 (7.5)	20.2 (8.0)	20.7 (8.1)

- 8 **Menton to back of head.** The horizontal distance from the tip of the chin (menton) to the back of the head, measured with a headboard.

Sample			Percentiles				
			1st	5th	50th	95th	99th
A	Men	cm (in)	15.7 (6.2)	16.5 (6.5)	18.2 (7.2)	20.0 (7.9)	20.7 (8.2)
B	Women	cm (in)	15.2 (6.0)	15.8 (6.2)	17.3 (6.8)	18.9 (7.4)	19.6 (7.7)

Static human physical characteristics – head (continued)

- 9 Sellion to top of head.** The vertical distance from the nasal root depression between the eyes (sellion), to the level of the top of the head, measured with a headboard.

Sample			Percentiles				
			1st	5th	50th	95th	99th
A Men	cm	9.7	10.1	11.2	12.4	12.9	
	(in)	(3.8)	(4.0)	(4.4)	(4.9)	(5.1)	
B Women	cm	9.0	9.5	10.5	11.7	12.2	
	(in)	(3.5)	(9.5)	(4.1)	(4.6)	(4.8)	

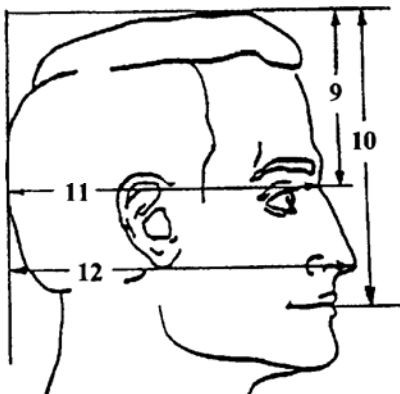

- 10 Stomion to top of head.** The vertical distance from the midpoint of the lips (stomion) to the level of the top of the head, measured with a headboard.

Sample			Percentiles				
			1st	5th	50th	95th	99th
A Men	cm	16.9	17.4	18.6	19.9	20.6	
	(in)	(6.7)	(6.6)	(7.3)	(7.8)	(8.1)	
B Women	cm	15.7	16.3	17.5	18.8	19.4	
	(in)	(6.1)	(6.4)	(6.9)	(7.4)	(7.6)	

- 11 Sellion to back of head.** The horizontal distance from the nasal root depression between the eyes (sellion), to the back of the head, measured with a headboard.

Sample			Percentiles				
			1st	5th	50th	95th	99th
A Men	cm	18.0	18.5	19.7	20.9	21.4	
	(in)	(7.1)	(7.3)	(7.8)	(8.2)	(8.4)	
B Women	cm	17.4	17.8	18.9	20.0	20.5	
	(in)	(6.6)	(7.1)	(7.4)	(7.9)	(8.4)	

- 12 Pronasale to back of head.** The horizontal distance from the tip of the nose (pronasale) to the back of the head, measured with a headboard.

Sample			Percentiles				
			1st	5th	50th	95th	99th
A Men	cm	20.0	20.5	22.0	23.2	23.9	
	(in)	(7.9)	(8.1)	(8.7)	(9.1)	(9.4)	
B Women	cm	19.2	19.7	21.0	22.2	22.8	
	(in)	(7.6)	(7.8)	(8.3)	(8.7)	(9.0)	

Static human physical characteristics – head (continued)

**13 Head length.** The maximum length of the head; measured from the most anterior point of the forehead between the brow-ridges (glabella) to the back of the head (occiput).

Sample		1st	Percentiles				
			5th	50th	95th	99th	
A	Men	cm (in)	18.0 (7.1)	18.5 (7.3)	19.7 (7.8)	20.9 (8.2)	21.3 (8.4)
B	Women	cm (in)	17.2 (6.8)	17.6 (7.0)	18.7 (7.4)	19.8 (7.8)	20.2 (8.0)

**14 Menton to top of head.** The vertical distance from the tip of the chin (menton) to the level of the top of the head, measured with a headboard.

Sample		1st	Percentiles				
			5th	50th	95th	99th	
A	Men	cm (in)	21.2 (8.4)	21.8 (8.6)	23.2 (8.6)	24.7 (9.1)	25.5 (9.4)
B	Women	cm (in)	19.8 (7.8)	20.4 (8.3)	21.8 (8.6)	23.2 (9.1)	23.8 (9.4)

**15 Menton-crinion length.** The vertical distance from the bottom of the chin (menton) to the midpoint of the hairline (crinion).

Sample		1st	Percentiles				
			5th	50th	95th	99th	
A	Men	cm (in)	16.6 (6.5)	17.4 (6.9)	19.1 (7.5)	20.9 (8.2)	21.6 (8.5)
B	Women	cm (in)	15.5 (6.1)	16.1 (6.3)	17.7 (7.0)	19.2 (7.6)	19.9 (7.8)

**16 Menton-subnasale length.** The distance from the bottom of the chin (menton) to the base of the nasal septum (subnasale).

Sample		1st	Percentiles				
			5th	50th	95th	99th	
A	Men	cm (in)	6.1 (2.4)	6.5 (2.7)	7.3 (2.9)	8.3 (3.3)	8.7 (3.3)
B	Women	cm (in)	5.7 (2.2)	6.0 (2.4)	6.5 (2.7)	7.8 (3.1)	8.3 (3.8)

Static human physical characteristics – head (continued)

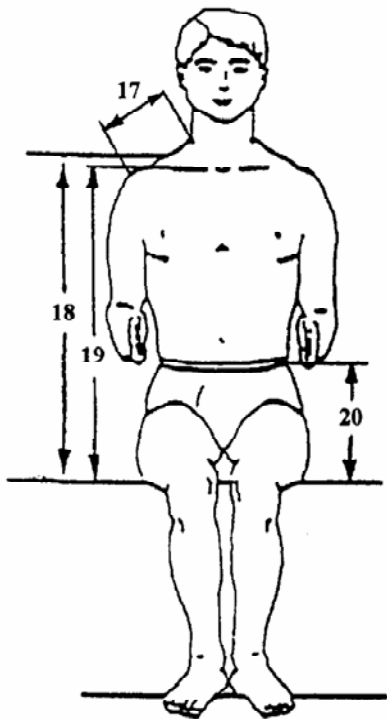

**17 Shoulder length.** The surface distance along the top of the shoulder from the junction of the neck and shoulder to the point of the shoulder (acromion).

Sample			Percentiles				
			1st	5th	50th	95th	99th
A	Men	cm (in)	12.4 (4.9)	13.3 (5.3)	15.0 (5.9)	16.9 (6.7)	17.7 (7.0)
B	Women	cm (in)	12.0 (4.7)	12.7 (5.0)	14.5 (5.7)	16.2 (6.4)	17.1 (6.7)

**18 Mid-shoulder height, sitting.** The vertical distance from the sitting surface of the shoulder halfway between the neck and the point of the shoulder, measured with the subject sitting.

Sample			Percentiles				
			1st	5th	50th	95th	99th
A	Men	cm (in)	56.3 (22.2)	58.3 (23.0)	63.0 (24.9)	67.7 (26.7)	69.4 (27.3)
B	Women	cm (in)	52.3 (20.6)	53.9 (21.2)	58.4 (23.0)	63.1 (24.8)	64.7 (25.5)

**19 Trunk (suprasternale) height, sitting.** The vertical distance from the sitting surface to the lowest point of the notch in the upper edge of the breast bone (suprasternale), measured with the subject sitting.

Sample			Percentiles				
			1st	5th	50th	95th	99th
A	Men	cm (in)	53.1 (20.9)	55.2 (21.7)	59.6 (23.5)	64.2 (25.3)	65.9 (25.9)
B	Women	cm (in)	49.8 (19.6)	51.1 (20.1)	55.3 (21.8)	59.6 (23.5)	61.2 (24.1)

**20 Waist height, sitting.** The vertical distance from the sitting surface to the level of the waist (natural indentation), measured with the subject sitting.

Sample			Percentiles				
			1st	5th	50th	95th	99th
A	Men	cm (in)	24.8 (9.8)	26.0 (10.2)	28.7 (11.3)	31.5 (12.4)	32.9 (13.0)
B	Women	cm (in)	22.8 (9.0)	24.4 (9.6)	28.0 (11.0)	31.5 (12.4)	32.7 (12.9)

## Static human physical characteristics - seated

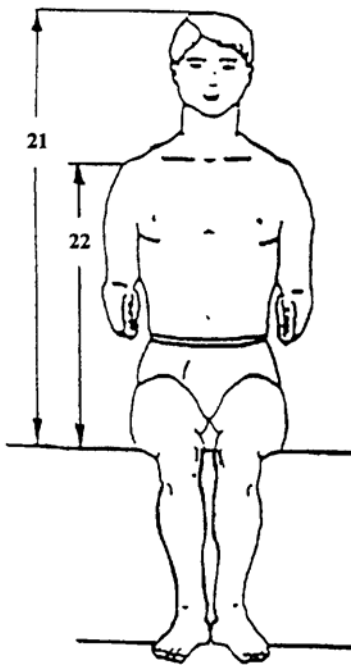

**21 Sitting height.** The vertical distance from the sitting surface to the top of the head, measured with the subject sitting.

Sample		Percentiles				
		1st	5th	50th	95th	99th
A	Men	cm 82.8 (in) (32.6)	85.5 (33.7)	91.4 (36.0)	97.2 (38.3)	99.1 (39.0)
B	Women	cm 77.5 (in) (30.5)	79.5 (31.3)	85.1 (33.5)	91.0 (35.8)	93.3 (36.7)

**22 Shoulder (acromiale) height, sitting.** The vertical distance from the sitting surface to the point of the shoulder (acromion), measured with the subject sitting.

Sample		Percentiles				
		1st	5th	50th	95th	99th
A	Men	cm 129.9 (in) (51.1)	134.2 (52.8)	144.2 (56.8)	154.6 (60.1)	158.4 (62.4)
B	Women	cm 120.4 (in) (47.4)	123.9 (48.8)	133.3 (52.5)	143.7 (56.6)	147.5 (58.1)

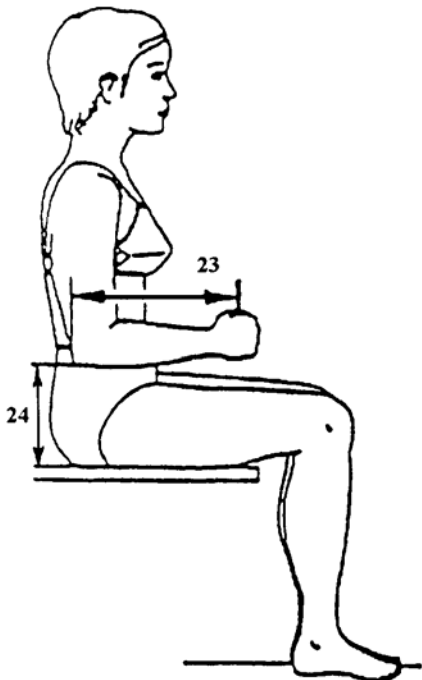

**23 Elbow-grip length.** The horizontal distance from the back of the elbow to the center of the clenched fist.

Sample		Percentiles				
		1st	5th	50th	95th	99th
A	Men	cm 32.3 (in) (12.7)	33.2 (13.1)	35.9 (14.1)	39.1 (15.4)	40.3 (15.9)
B	Women	cm 28.9 (in) (11.4)	30.0 (11.8)	32.8 (12.9)	35.8 (14.1)	37.2 (14.7)

**24 Elbow rest height.** The vertical distance from the sitting surface to the bottom of the tip of the elbow, measured with the subject sitting and the forearm held horizontally.

Sample		Percentiles				
		1st	5th	50th	95th	99th
A	Men	cm 16.8 (in) (6.6)	18.4 (7.2)	23.2 (9.1)	27.4 (10.8)	29.2 (11.5)
B	Women	cm 15.8 (in) (6.2)	17.6 (6.9)	22.1 (8.7)	26.4 (10.4)	28.2 (11.1)

Static human physical characteristics – seated (continued)

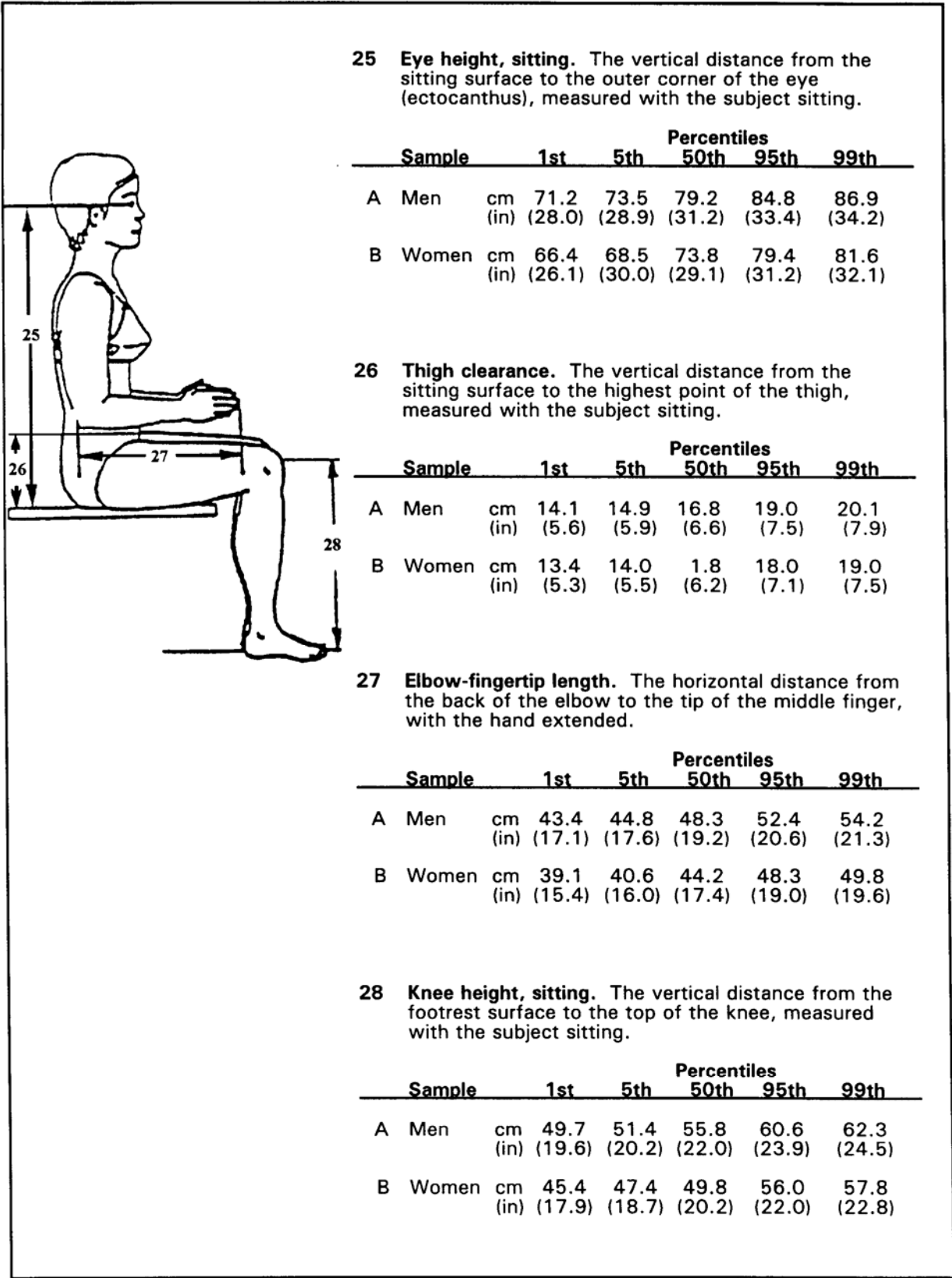

Static human physical characteristics – seated (continued)

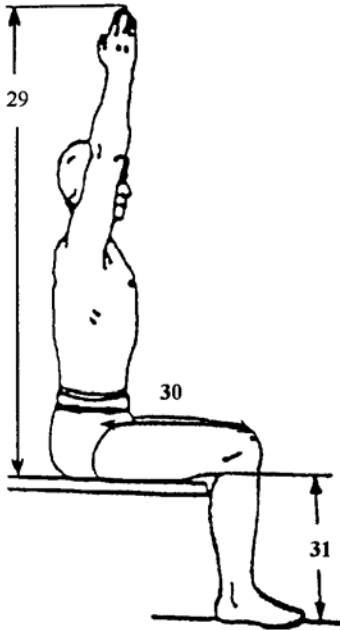

**29 Vertical reach, sitting.** The vertical distance from the sitting surface to the tip of the middle finger, measured with the subject sitting and the arm, hand, and fingers extended vertically.

Sample		Percentiles				
		1st	5th	50th	95th	99th
A	Men	cm 129.3 (in) (50.1)	133.8 (52.7)	143.3 (56.4)	153.2 (60.3)	156.7 (61.7)
B	Women	cm 119.7 (in) (47.1)	123.3 (48.5)	132.7 (52.2)	141.8 (55.8)	145.4 (57.2)

**30 Abdominal depth, sitting.** The depth of the abdomen, with the subject sitting.

Sample		Percentiles				
		1st	5th	50th	95th	99th
A	Men	cm 18.6 (in) (7.3)	19.9 (7.8)	23.6 (9.3)	29.1 (11.5)	31.4 (12.4)
B	Women	cm 17.3 (in) (6.1)	18.5 (7.3)	21.9 (8.6)	27.1 (10.7)	29.5 (11.6)

**31 Popliteal height, sitting.** The vertical distance from the footrest surface to the underside of the lower leg, measured with the subject sitting.

Sample		Percentiles				
		1st	5th	50th	95th	99th
A	Men	cm 37.8 (in) (14.9)	39.5 (15.6)	43.3 (17.1)	47.6 (18.7)	49.5 (19.5)
B	Women	cm 33.7 (in) (13.3)	35.1 (13.8)	38.9 (15.3)	42.9 (16.9)	44.6 (17.6)

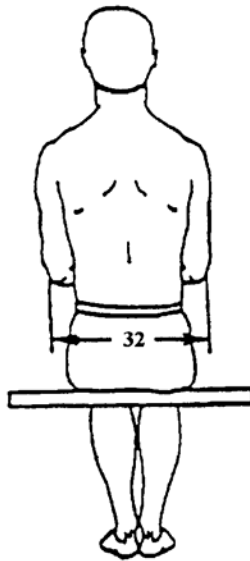

**32 Forearm-forearm breadth, sitting.** The horizontal distance across the body between the outer surfaces of the forearms, measured with the forearms flexed and held against the body.

Sample		Percentiles				
		1st	5th	50th	95th	99th
A	Men	cm 45.1 (in) (17.8)	47.79 (18.8)	54.5 (21.5)	62.1 (24.5)	65.3 (25.7)
B	Women	cm 39.4 (in) (15.5)	41.5 (16.3)	46.7 (18.4)	52.8 (20.8)	56.0 (22.1)

Static human physical characteristics – seated (continued)

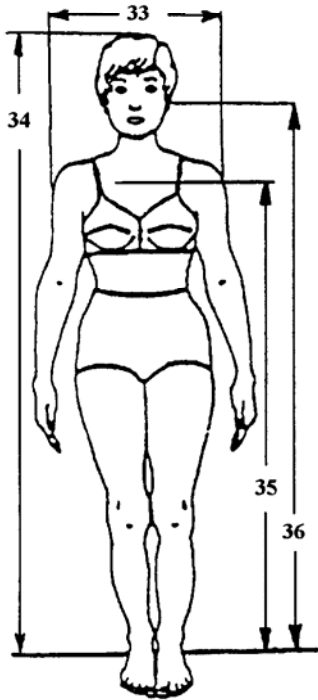

**33 Shoulder (bideloid) breadth.** The horizontal distance across the upper arms between the maximum bulges of the deltoid muscles; the arms are hanging and relaxed.

Sample		Percentiles				
		1st	5th	50th	95th	99th
A	Men	cm 43.4 (in) (17.1)	45.0 (17.7)	49.1 (19.3)	53.5 (21.1)	55.2 (21.7)
B	Women	cm 38.0 (in) (15.0)	39.7 (15.6)	43.1 (17.0)	47.2 (18.6)	49.2 (19.4)

**34 Stature.** The vertical distance from the floor to the top of the head.

Sample		Percentiles				
		1st	5th	50th	95th	99th
A	Men	cm 160.3 (in) (63.1)	164.7 (64.8)	175.5 (69.1)	186.7 (73.5)	190.9 (75.2)
B	Women	cm 148.3 (in) (58.4)	152.8 (60.2)	162.7 (64.1)	173.7 (68.4)	178.0 (70.1)

**35 Suprasternale height.** The vertical distance from the floor to the lowest point of the notch in the upper edge of the breast bone (suprasternale).

Sample		Percentiles				
		1st	5th	50th	95th	99th
A	Men	cm 130.2 (in) 51.3	134.3 (52.9)	143.7 (56.6)	153.7 (60.5)	157.5 (62.0)
B	Women	cm 120.7 (in) (47.5)	124.1 (48.9)	132.9 (52.3)	142.5 (56.1)	146.4 (57.6)

**36 Tragion height, standing.** The vertical distance from the floor to the tragion, the cartilaginous notch at the front of the ear.

Sample		Percentiles				
		1st	5th	50th	95th	99th
A	Men	cm 147.4 (in) (58.0)	151.9 (59.8)	162.4 (63.9)	173.4 (68.3)	177.5 (69.9)
B	Women	cm 136.3 (in) (53.7)	140.7 (55.4)	150.4 (59.2)	161.2 (63.5)	165.4 (65.1)

Static human physical characteristics - standing



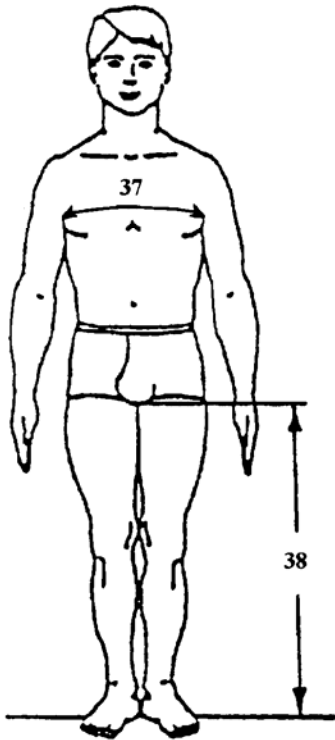

**37 Chest (bust) circumference.** The circumference of the torso measured at the level of the nipples.

Sample			Percentiles				
			1st	5th	50th	95th	99th
A	Men	cm	84.5	88.6	98.7	111.3	116.8
		(in)	(33.3)	(34.9)	(38.9)	(43.8)	(50.0)
B	Women	cm	78.1	81.4	90.1	102.2	107.7
		(in)	(30.8)	(32.1)	(35.5)	(40.2)	(42.4)

**38 Crotch height.** The vertical distance from the floor to the midpoint of the crotch.

Sample			Percentiles				
			1st	5th	50th	95th	99th
A	Men	cm	73.2	76.4	83.5	91.6	94.6
		(in)	(28.8)	(30.1)	(32.9)	(36.1)	(37.2)
B	Women	cm	67.0	70.0	77.0	84.6	88.1
		(in)	(26.4)	(27.6)	(30.3)	(33.3)	(34.7)

**39 Waist circumference (natural indentation).** The horizontal circumference of the torso at the level of the natural indentation of the waist.

Sample			Percentiles				
			1st	5th	50th	95th	99th
A	Men	cm	69.9	73.0	83.4	97.1	102.9
		(in)	(27.5)	(28.7)	(32.8)	(38.2)	(40.5)
B	Women	cm	60.7	63.7	71.7	84.3	91.0
		(in)	(23.9)	(25.1)	(28.2)	(33.2)	(35.8)

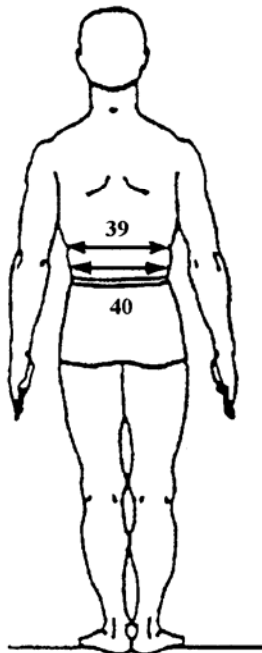

**40 Waist circumference (omphalion).** The horizontal circumference of the torso at the level of the navel (omphalion).

Sample			Percentiles				
			1st	5th	50th	95th	99th
A	Men	cm	70.0	73.3	85.6	101.6	107.7
		(in)	(27.6)	(28.9)	(33.7)	(40.0)	(42.4)
B	Women	cm	64.4	67.6	78.1	94.6	102.6
		(in)	(25.4)	(26.6)	(30.8)	(37.2)	(40.4)

Static human physical characteristics – standing (continued)

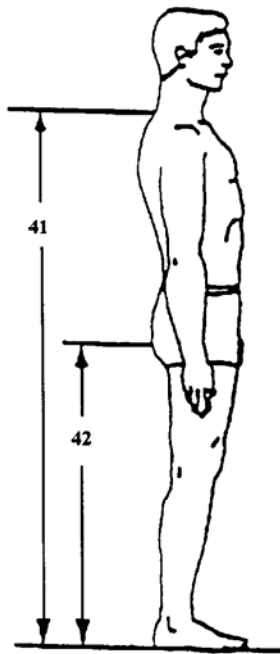

**41 Cervicale height.** The vertical distance from the floor to the cervicale, the tip of the spine of the seventh cervical vertebra at the base of the neck.

Sample		Percentiles				
		1st	5th	50th	95th	99th
A	Men	cm 137.4 (in) (54.1)	141.8 (55.8)	151.8 (59.8)	162.4 (63.9)	166.1 (65.4)
B	Women	cm 127.3 (in) (50.1)	131.4 (51.7)	140.6 (55.4)	150.8 (59.4)	154.8 (60.9)

**42 Buttock height.** The vertical distance from the floor to the maximum posterior protrusion of the buttock.

Sample		Percentiles				
		1st	5th	50th	95th	99th
A	Men	cm 78.4 (in) (30.9)	81.5 (32.1)	88.5 (34.8)	96.9 (38.1)	100.5 (39.6)
B	Women	cm 73.9 (in) (29.1)	76.7 (30.2)	83.7 (33.0)	91.5 (36.0)	94.9 (37.4)

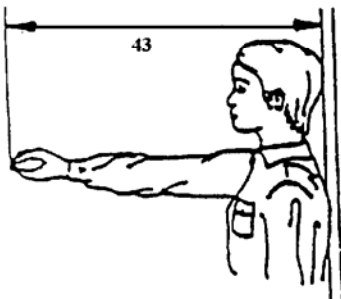

**43 Functional (thumb-tip) reach.** The horizontal distance from the wall to the tip of the thumb, measured with the subject's shoulders against the wall, the arm extended forward, and the index finger touching the tip of the thumb.

Sample		Percentiles				
		1st	5th	50th	95th	99th
A	Men	cm 72.0 (in) (28.4)	73.9 (29.1)	80.0 (31.5)	86.7 (34.1)	89.7 (35.3)
B	Women	cm 65.8 (in) (25.9)	67.7 (26.7)	73.4 (28.9)	79.7 (31.4)	82.4 (32.4)

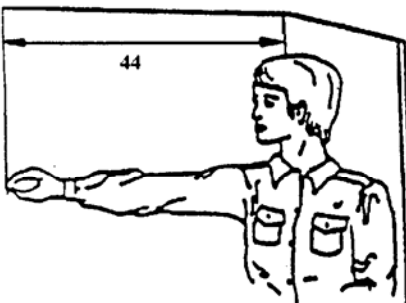

**44 Functional (thumb-tip) reach, extended.** Measured similarly to functional (thumb-tip) reach, except that the right shoulder is extended forward as far as possible, while the left shoulder is kept pressed firmly against the wall.

Sample		Percentiles				
		1st	5th	50th	95th	99th
A	Men	cm 77.9 (in) (30.7)	80.5 (31.7)	87.3 (34.4)	94.2 (37.1)	97.7 (38.5)
B	Women	cm 71.2 (in) (28.0)	73.5 (28.9)	79.6 (31.3)	86.2 (33.9)	89.0 (35.0)

Static human physical characteristics – standing (continued)

**45 Hand breadth.** The breadth of the hand, measured across the ends of the metacarpal bones (metacarpal-phalangeal joints).

Sample		1st	Percentiles				
			5th	50th	95th	99th	
A	Men	cm (in)	8.1 (3.2)	8.4 (3.3)	9.0 (3.5)	9.8 (3.9)	10.0 (3.9)
B	Women	cm (in)	7.1 (2.8)	7.3 (2.9)	7.9 (3.1)	8.6 (3.4)	8.9 (3.5)

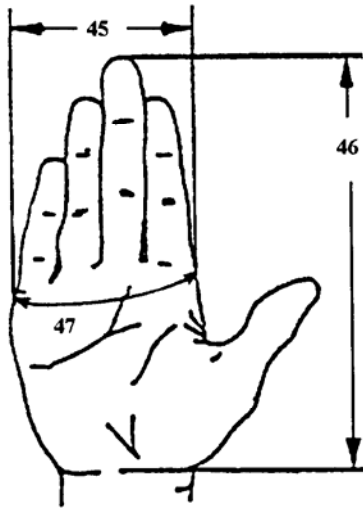

**46 Hand length.** The distance from the base of the hand at the wrist crease to the tip of the middle finger.

Sample		1st	Percentiles				
			5th	50th	95th	99th	
A	Men	cm (in)	17.3 (6.8)	17.9 (7.1)	19.3 (7.6)	21.1 (8.3)	21.9 (8.6)
B	Women	cm (in)	15.9 (6.3)	16.5 (6.5)	18.0 (7.1)	19.7 (7.8)	20.5 (8.1)

**47 Hand circumference.** The circumference of the hand, measured around the knuckles (metacarpal-phalangeal joints).

Sample		1st	Percentiles				
			5th	50th	95th	99th	
A	Men	cm (in)	19.2 (7.6)	19.9 (7.8)	21.3 (8.4)	23.0 (9.1)	23.7 (9.3)
B	Women	cm (in)	16.7 (6.6)	17.3 (6.8)	18.6 (7.3)	20.0 (7.9)	20.7 (8.2)

## Static human physical characteristics – hands

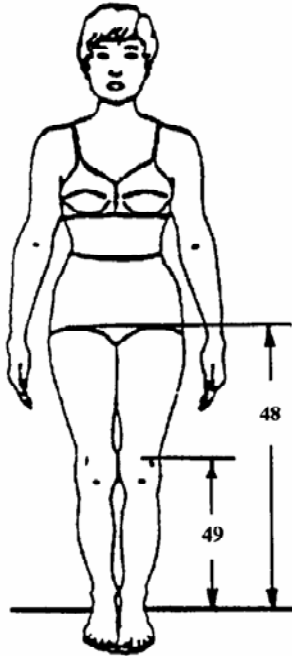

**48 Hip (trochanteric) height.** The vertical distance from the floor to the level of the maximum posterior protrusion of the greater trochanter of the femur (trochanterion).

Sample		Percentiles				
		1st	5th	50th	95th	99th
A Men	cm (in)	82.1 (32.3)	85.3 (33.6)	92.7 (36.5)	100.9 (39.7)	104.0 (40.9)
B Women	cm (in)	76.1 (30.0)	78.9 (31.1)	86.0 (33.9)	93.8 (36.9)	97.5 (38.4)

**49 Knee height, midpatella.** The vertical distance from the footrest surface to the top of the knee, measured with the subject sitting.

Sample		Percentiles				
		1st	5th	50th	95th	99th
A Men	cm (in)	44.3 (17.4)	46.1 (18.2)	50.4 (19.8)	55.2 (21.7)	56.8 (22.4)
B Women	cm (in)	39.9 (15.7)	41.7 (16.4)	45.8 (18.0)	50.3 (19.8)	52.3 (20.6)

Static human physical characteristics – standing position

	<b>Light clothing</b>	<b>Medium clothing</b>	<b>Heavy clothing</b>
Abdomen depth	2.39 cm (0.94 in)	3.00 cm (1.18 in)	6.45 cm (2.54 in)
Buttock-knee length	0.51 cm (0.20 in)	0.76 cm (0.30 in)	1.78 cm (0.70 in)
Chest depth	1.04 cm (0.41 in)	2.44 cm (0.96 in)	3.91 cm (1.54 in)
Elbow breadth	1.42 cm (0.56 in)	2.64 cm (1.04 in)	5.38 cm (2.12 in)
Hip breadth	1.42 cm (0.56 in)	1.93 cm (0.76 in)	3.56 cm (1.40 in)
Hip breadth, sitting	1.42 cm (0.56 in)	1.93 cm (0.76 in)	3.56 cm (1.40 in)
Knee breadth (both)	1.22 cm (0.48 in)	1.22 cm (0.48 in)	4.27 cm (1.68 in)
Knee height, sitting	3.35 cm (1.32 in)	3.35 cm (1.32 in)	3.66 cm (1.44 in)
Shoulder breadth	0.61 cm (0.24 in)	2.24 cm (0.88 in)	2.95 cm (1.16 in)
Shoulder-elbow length	0.36 cm (0.14 in)	1.27 cm (0.50 in)	1.57 cm (0.62 in)
Shoulder height, sitting	0.41 cm (0.16 in)	1.47 cm (0.58 in)	2.03 cm (0.80 in)

Additive effects of clothing on anthropometric measures

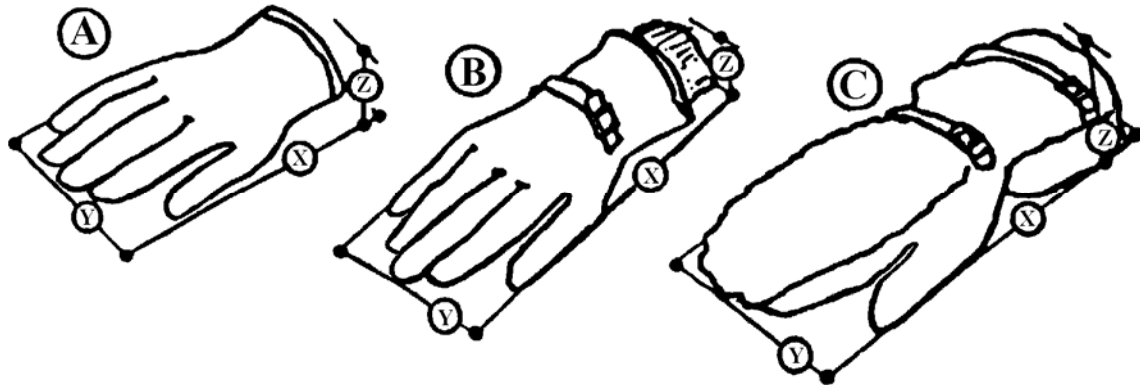

Hand position	A Anti-contact glove			B Wet-cold glove			C Arctic glove			
	X	Y	Z	X	Y	Z	X	Y	Z	
Extended flat	cm (in)	26.7 (10.5)	11.9 (4.7)	6.4 (2.5)	27.2 (10.7)	14.5 (5.7)	7.6 (3.0)	42.2 (16.6)	13.7 (5.4)	9.1 (3.6)
Closed as fist	cm (in)	17.8 (7.0)	12.7 (5.0)	8.4 (3.3)	18.5 (7.3)	14.7 (5.8)	9.4 (3.7)	36.3 (14.3)	13.2 (5.2)	13.7 (5.4)
Grasping handle										
0.6 cm (0.24 in) diameter	cm (in)	17.8 (7.0)	12.7 (5.0)	8.9 (3.5)	18.5 (7.3)	14.0 (5.5)	8.9 (3.5)	35.6 (14.0)	14.0 (5.5)	11.4 (4.5)
2.5 cm (1.0 in) diameter	cm (in)	17.8 (7.0)	12.7 (5.0)	8.9 (3.5)	18.5 (7.3)	13.5 (5.3)	10.2 (4.0)	35.6 (14.0)	13.2 (5.2)	11.4 (4.5)
5.0 cm (2.0 in) diameter	cm (in)	19.0 (7.5)	11.4 (4.5)	10.7 (4.2)	20.3 (8.0)	11.9 (4.7)	10.2 (4.0)	38.1 (15.0)	13.7 (5.4)	12.7 (5.0)
Grasping knob										
0.6 cm (0.24 in) diameter	cm (in)	20.3 (8.0)	9.7 (3.8)	10.9 (4.3)	22.9 (9.0)	11.7 (4.6)	10.2 (4.0)	39.4 (15.5)	12.2 (4.8)	11.4 (4.5)
2.5 cm (1.0 in) diameter	cm (in)	22.8 (9.0)	8.9 (3.5)	10.2 (4.0)	22.9 (9.0)	11.4 (4.5)	10.2 (4.0)	40.1 (15.8)	12.2 (4.8)	12.2 (4.8)
5.0 cm (2.0 in) diameter	cm (in)	24.1 (9.5)	9.4 (3.7)	9.4 (3.7)	23.4 (9.2)	11.4 (4.5)	10.7 (4.1)	40.5 (15.9)	11.9 (4.7)	12.2 (4.8)

Additive effects of clothing on anthropometric measures (continued)

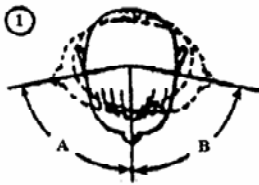

Neck Rotation,  
Right (A), Left (B)

Joint movement	Range of motion (degrees)			
	Males		Females	
	5th percentile	95th percentile	5th percentile	95th percentile
Neck, rotation right	73.3	99.6	74.9	108.8
Neck, rotation left	74.3	99.1	72.2	109.0



Neck Extension (A)  
Flexion (B)

Joint movement	Range of motion (degrees)			
	Males		Females	
	5th percentile	95th percentile	5th percentile	95th percentile
Neck, flexion	34.5	71.0	46.0	84.4
Neck, extension	65.4	103.0	64.9	103.0

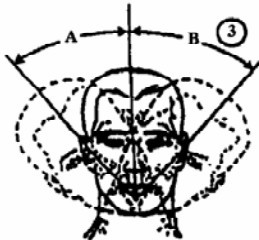

Neck Lateral Bend  
Right (A), Left (B)

Joint movement	Range of motion (degrees)			
	Males		Females	
	5th percentile	95th percentile	5th percentile	95th percentile
Neck, lateral right	34.9	63.5	37.0	63.2
Neck, lateral left	35.5	63.5	29.1	77.2

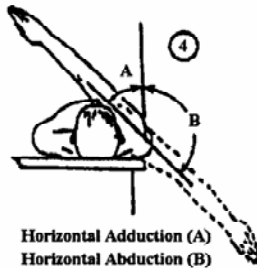

Horizontal Adduction (A)  
Horizontal Abduction (B)

Joint movement	Range of motion (degrees)			
	Males		Females	
	5th percentile	95th percentile	5th percentile	95th percentile
Shoulder, abduction	173.2	188.7	172.6	192.9

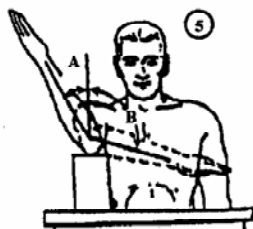

Shoulder Rotation,  
Lateral (A), Medial (B)

Joint movement	Range of motion (degrees)			
	Males		Females	
	5th percentile	95th percentile	5th percentile	95th percentile
Shoulder, rotation lat	46.3	96.7	53.8	85.8
Shoulder, rotation med	90.5	126.6	95.8	130.9

## Joint movement ranges

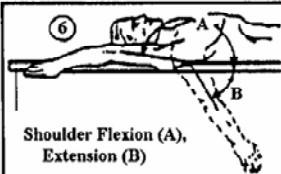

Shoulder Flexion (A),  
Extension (B)

Joint movement	Range of motion (degrees)			
	Males		Females	
	5th percentile	95th percentile	5th percentile	95th percentile
Shoulder, flexion	164.4	210.9	152.0	217.0
Shoulder, extension	39.6	83.3	33.7	87.9



Elbow Flexion (B),  
Extension (A)

Joint movement	Range of motion (degrees)			
	Males		Females	
	5th percentile	95th percentile	5th percentile	95th percentile
Elbow, flexion	140.5	159.0	144.9	165.9

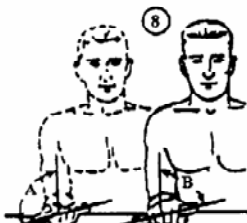

Forearm Supination (A),  
Pronation (B)

Joint movement	Range of motion (degrees)			
	Males		Females	
	5th percentile	95th percentile	5th percentile	95th percentile
Forearm, pronation	78.2	116.1	82.3	118.9
Forearm, supination	83.4	125.8	90.4	139.5



Wrist Ulnar Bend(A),  
Radial Bend (B)

Joint movement	Range of motion (degrees)			
	Males		Females	
	5th percentile	95th percentile	5th percentile	95th percentile
Wrist, radial	16.9	36.7	16.1	36.1
Wrist, ulnar	18.6	47.9	21.5	43.0

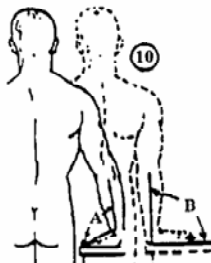

Wrist Flexion (A),  
Extension (B)

Joint movement	Range of motion (degrees)			
	Males		Females	
	5th percentile	95th percentile	5th percentile	95th percentile
Wrist, flexion	61.5	94.8	68.3	98.1
Wrist, extension	40.1	78.0	42.3	74.7

Joint movement ranges (continued)





Hip Flexion

Range of motion (degrees)

Males Females

<u>Joint movement</u>	<u>5th percentile</u>	<u>95th percentile</u>	<u>5th percentile</u>	<u>95th percentile</u>
Hip, flexion	116.5	148.0	118.5	145.0

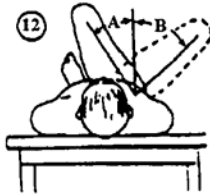

Hip Adduction (A),  
Abduction (B)

Range of motion (degrees)

Males Females

<u>Joint movement</u>	<u>5th percentile</u>	<u>95th percentile</u>	<u>5th percentile</u>	<u>95th percentile</u>
Hip, abduction	26.8	53.5	27.2	55.9



Knee Flexion, Prone

Range of motion (degrees)

Males Females

<u>Joint movement</u>	<u>5th percentile</u>	<u>95th percentile</u>	<u>5th percentile</u>	<u>95th percentile</u>
Knee, flexion	118.4	145.6	125.2	145.2



Ankle Plantar Extension (A),  
Dorsi Flexion (B)

Range of motion (degrees)

Males Females

<u>Joint movement</u>	<u>5th percentile</u>	<u>95th percentile</u>	<u>5th percentile</u>	<u>95th percentile</u>
Ankle, planar	36.1	79.6	44.2	91.1
Ankle, dorsi	8.1	19.9	6.9	17.4

Joint movement ranges (continued)

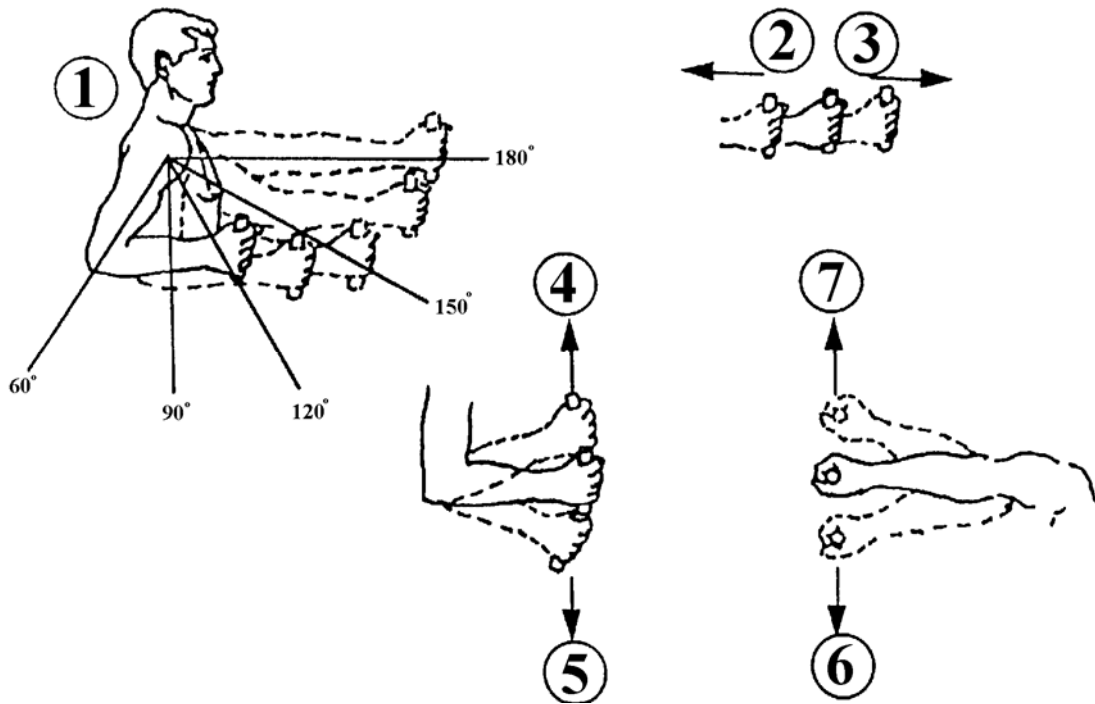

Arm strength N (lb) Design criteria levels

Degree elbow flexion	2 Pull		3 Push		4 Up		5 Down		6 In		7 Out	
	L	R	L	R	L	R	L	R	L	R	L	R
180°	177.6 (40)	184.8 (41.6)	149.6 (33.6)	177.6 (40)	32 (7.2)	49.6 (11.2)	46.6 (10.4)	60.8 (13.6)	46.6 (10.4)	71.2 (16)	28.8 (6.4)	49.6 (11.2)
150°	149.6 (33.6)	199.2 (44.8)	106.4 (24)	149.6 (33.6)	53.6 (12)	64 (14.4)	64 (14.4)	71.2 (16)	53.6 (12)	71.2 (16)	28.8 (6.4)	53.6 (12)
120°	120.8 (27.2)	149.6 (33.6)	92.8 (20.8)	128 (28.8)	60.8 (13.6)	85.6 (19.2)	74.4 (16.8)	92.8 (20.8)	71.2 (16)	78.4 (17.6)	36 (8)	53.6 (12)
90°	113.6 (25.6)	132 (29.6)	78.4 (17.6)	128 (28.8)	60.8 (13.6)	71.2 (16)	74.4 (16.8)	92.8 (20.8)	56.8 (12.8)	64 (14.4)	36 (8)	56.8 (12.8)
60°	92.8 (20.8)	85.6 (19.2)	78.4 (17.6)	120.8 (27.2)	53.6 (12)	71.2 (16)	64 (14.4)	71.2 (16)	60.8 (13.6)	71.2 (16)	42.4 (9.6)	60.8 (13.6)

**Note.** L = Left  
R = Right

Muscle strength of the arm, hand, and thumb (5<sup>th</sup> percentile male)

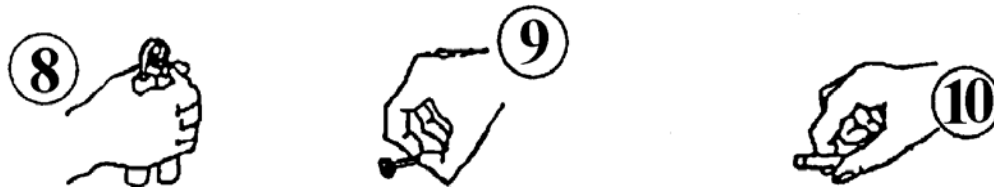

**Hand and thumb-finger strength N (lb)**

	8		9		10	
	Hand grip L	Hand grip R	Thumb-finger grip (palmer)	Thumb-finger grip (tips)	Thumb-finger grip (palmer)	Thumb-finger grip (tips)
Momentary hold	200 (44.8)	208 (47.2)	48 (10.4)	48 (10.4)		
Sustained hold	116 (26.4)	124 (28)	28 (6.4)	28 (6.4)		

**Note.** L = Left  
R = Right

Muscle strength of the arm, hand, and thumb (5<sup>th</sup> percentile male)  
(continued)



**A. Standing two-handed pull: 38 cm (15.0) level.** Standing with feet 45 cm (17.7 in) apart and knees bent; bending at the waist, grasping both sides of a 45 cm (17.7 in) handle located directly in front, 38 cm (15.0 in) above standing surface, and pulling, using primarily arms, shoulders, and legs

Strength measurements	5th percentile		95th percentile	
	Male	Female	Male	Female
Mean force (N)	737.5	330.9	1354.5	817.6
Mean force (lbf)	(165.80)	(74.39)	(304.50)	(183.80)
Peak force (N)	844.7	396.9	1437.2	888.3
Peak force (lbf)	(189.90)	(89.23)	(323.10)	(199.70)



**B. Standing two-handed pull: 50 cm (19.7 in) level.** Standing with feet 45 cm (17.7 in) apart and knees straight; bending at the waist, grasping both sides of a 45 cm (17.7 in) handle located directly in front, 50 cm (19.7 in) above standing surface, and pulling, using primarily arms and shoulders

Strength measurements	5th percentile		95th percentile	
	Male	Female	Male	Female
Mean force (N)	758.0	326.1	1341.6	840.7
Mean force (lbf)	(170.41)	(73.31)	(301.60)	(189.00)
Peak force (N)	830.9	374.1	1441.7	905.2
Peak force (lbf)	(186.79)	(84.10)	(324.11)	(203.50)



**C. Standing two-handed pull: 100 cm (39.4 in) level.** Standing erect with feet 45 cm (17.7 in) apart, grasping both sides of a 45 cm (17.7 in) handle located directly in front, 100 cm (39.4 in) above the standing surface, and pulling, using the arms

Strength measurements	5th percentile		95th percentile	
	Male	Female	Male	Female
Mean force (N)	444.4	185.0	931.0	443.0
Mean force (lbf)	(99.91)	(41.59)	(209.30)	(99.59)
Peak force (N)	504.0	218.0	988.4	493.3
Peak force (lbf)	(113.30)	(49.01)	(222.20)	(110.90)

Static muscle strength data for vertical pull exertions



D. **Standing two-handed push: 150 cm (59.1 in) level.** Standing erect with feet 45 cm (17.7 in) apart grasping from below, both sides of a 45 cm (17.7 in) handle located directly in front, 150 cm (59.1 in) above standing surface, pushing upward using arms and shoulders

Strength measurements	5th Percentile		95th Percentile	
	Male	Female	Male	Female
Mean force (N)	408.8	153.5	1016.9	379.9
Mean force (lbf)	(91.9)	(34.51)	(228.61)	(85.41)
Peak force (N)	472.8	187.7	1094.3	430.1
Peak force (lbf)	(106.29)	(42.20)	(246.02)	(96.69)



E. **Standing one-handed pull: 100 cm (39.4 in) level.** Standing erect with feet 15 cm (5.9 in) apart dominant hand grasping underside of D-ring located directly to the side, 100 cm (39.4 in) above standing surface, pulling upward while keeping shoulder square and other arm relaxed at side

Strength measurements	5th Percentile		95th Percentile	
	Male	Female	Male	Female
Mean force (N)	214.8	102.8	627.6	283.8
Mean force (lbf)	(48.29)	(23.11)	(141.09)	(63.8)
Peak force (N)	258.9	131.7	724.2	322.5
Peak force (lbf)	(58.20)	(29.61)	(162.81)	(72.50)



F. **Seated one-handed pull: seat centerline 45 cm (39.4 in) level.** Sitting erect with feet 55 cm (21.7 in) apart, dominant hand grasping underside of D-ring located directly to the front, 45 cm (17.7 in) above the floor, pulling upward while keeping shoulder square and other arm resting in lap

Strength measurements	5th Percentile		95th Percentile	
	Male	Female	Male	Female
Mean force (N)	222.3	106.3	678.4	391.9
Mean force (lbf)	(49.98)	(23.90)	(152.51)	(88.11)
Peak force (N)	273.1	127.2	758.4	450.6
Peak force (lbf)	(61.40)	(28.60)	(170.50)	(101.30)

Static muscle strength data for vertical pull exertions (continued)



**G. Seated one-handed pull: side of seat, 45 cm (17.7 in) level.** Sitting erect with feet 55 cm (21.7 in) apart, dominant hand grasping underside of D-ring located a short distance to side, 45 cm (17.7 in) above the floor, pulling upward while keeping shoulders square and other arm resting in lap

Strength measurements	5th percentile		95th percentile	
	Male	Female	Male	Female
Mean force (N)	408.8	153.5	1016.9	379.9
Mean force (lbf)	(91.90)	(34.51)	(228.61)	(85.41)
Peak force (N)	472.8	187.7	1094.3	430.1
Peak force (lbf)	(106.29)	(42.20)	(246.02)	(96.69)



**H. Seated two-handed pull: centerline of seat, 38 cm (14.96 in) level.** Sitting erect with feet 55 cm (21.7 in) apart, bending slightly at waist, grasping both sides of 15 cm (5.9 in) handle located directly to the front, 38 cm (15.0 in) above the floor, pulling upward using arms and shoulders, keeping arms off thighs

Strength measurements	5th percentile		95th percentile	
	Male	Female	Male	Female
Mean force (N)	214.8	102.8	627.6	283.8
Mean force (lbf)	(48.29)	(23.11)	(141.09)	(63.80)
Peak force (N)	258.9	131.7	724.2	322.5
Peak force (lbf)	(58.20)	(29.61)	(162.81)	(72.50)



**I. Seated two-handed pull: centerline of seat, 50 cm (19.7 in) level.** Sitting erect with feet 55 cm (21.7 in) apart, bending slightly at the waist, grasping both sides of 15 cm (5.9 in) handle located directly to the front, 50 cm (19.7 in) above the floor, pulling upward using arms and shoulders, keeping arms off thighs

Strength measurements	5th percentile		95th percentile	
	Male	Female	Male	Female
Mean force (N)	222.3	106.3	678.4	391.9
Mean force (lbf)	(49.98)	(23.90)	(152.51)	(88.11)
Peak force (N)	273.1	127.2	758.4	450.6
Peak force (lbf)	(61.40)	(28.60)	(170.50)	(101.30)

Static muscle strength data for vertical pull exertions (continued)

<b>Exertable horizontal force</b>	<b>Applied with</b>	<b>Condition (<math>\mu</math>: coefficient of friction)</b>
110 N (24.7 lbf) push or pull	both hands or one shoulder or the back	with low traction $0.2 < \mu < 0.3$
200 N (45.0 lbf) push or pull	both hands or one shoulder or the back	with medium traction $\mu = 0.6$
240 N (54.0 lbf) push	one hand	if braced against a vertical wall 510-1520 mm (20.08-59.84 in) from and parallel to the push panel
310 N (70.0 lbf) push or pull	both hands or one shoulder or the back	with high traction $\mu > 0.9$
490 N (110.2 lbf) push or pull	both hands or one shoulder or the back	if braced against a vertical wall 510-1780 mm (20.08-70.08 in) from and parallel to the panel or if anchoring the feet on a perfectly non-slip ground (like a footrest)
730 N (164.1 lbf) push	the back	if braced against a vertical wall 580-1090 mm (22.83-42.91 in) from and parallel to the push panel or if the anchoring the feet on a perfectly non-slip ground (like a footrest)

## Horizontal push and pull forces that can be exerted

**LOW/MEDIUM/HIGH TRACTION**

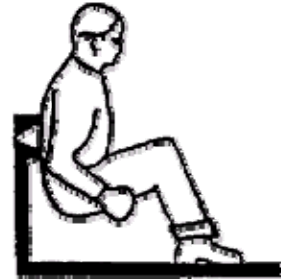
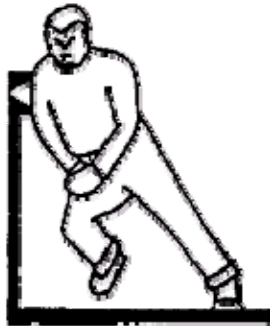
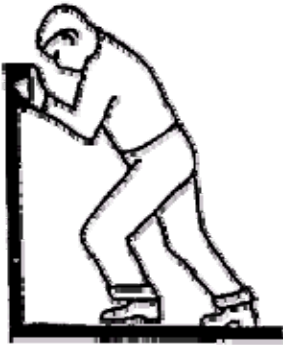

**USE OF FOOTREST**

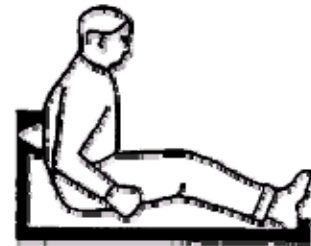
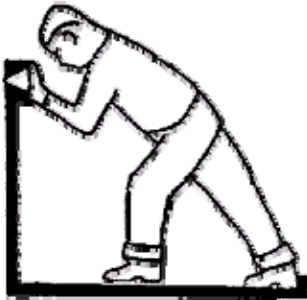

**BRACED AGAINST VERTICAL WALL**

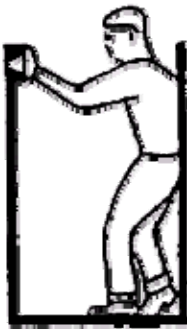

Examples of push force conditions



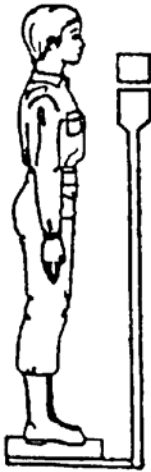

- A. Weight (clothed) wearing fatigues and combat boots; standing in center of scale.

	5th percentile		95th percentile	
	Male	Female	Male	Female
Weight (kg)	58.6	48.8	90.2	74.6
(lb)	129.1	107.6	198.8	164.5

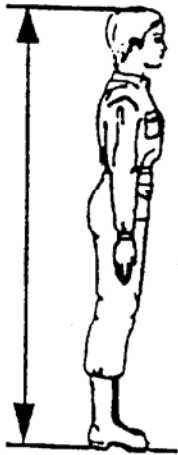

- B. Stature (clothed) standing erect; heels together; weight distributed equally on both feet; measured from standing surface to top of head.

	5th percentile		95th percentile	
	Male	Female	Male	Female
Stature (cm)	168.5	156.8	189.0	178.7
(in)	66.4	61.8	74.4	70.3

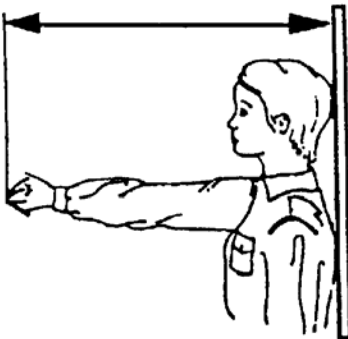

- C. Functional reach- standing erect; looking straight ahead; both shoulders against wall; right arm horizontal measured from wall to tip of index finger.

	5th percentile		95th percentile	
	Male	Female	Male	Female
Functional (cm)	72.6	64.0	86.4	79.0
reach (in)	28.6	25.2	34.0	31.1

## Anthropometric data for common working positions

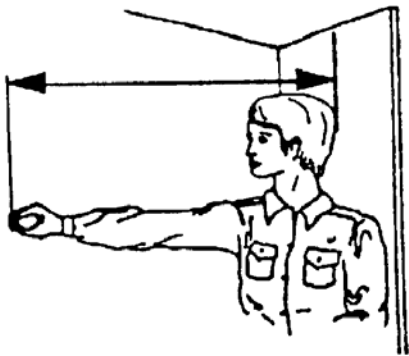

D. Functional reach, extended- standing erect; looking straight ahead; right shoulder extended as far forward as possible while back of left shoulder firmly against wall; arm horizontal measured from wall to tip of index finger.

	5th percentile		95th percentile	
	Male	Female	Male	Female
Functional reach(cm)	84.2	73.5	101.2	92.7
extended (in)	33.2	28.9	39.8	36.5

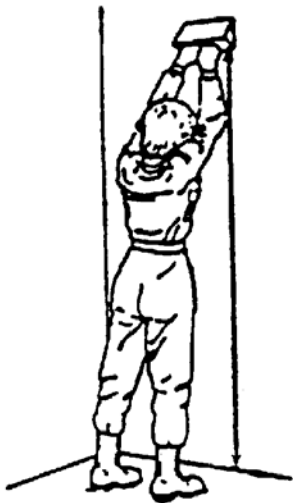

E. Overhead reach height- standing with heels 23 cm (9 in) apart and toes 15 cm (6 in) from wall; arms extended overhead with fists touching and against wall; 1st phalanges horizontal measured from floor to highest point on 1st phalanges.

	5th percentile		95th percentile	
	Male	Female	Male	Female
Overhead reach(cm)	200.4	185.3	230.5	215.1
height (in)	78.9	73.0	90.8	84.7



F. Overhead reach breadth- standing with heels 23 cm (9 in) apart and toes 15 cm (6 in) from wall; arms extended overhead with fists touching and against wall; 1st phalanges horizontal measured horizontally across arms or shoulders, whichever is wider.

	5th percentile		95th percentile	
	Male	Female	Male	Female
Overhead reach (cm)	35.2	31.5	41.9	37.9
breadth (in)	13.9	12.4	16.5	14.9

Anthropometric data for common working positions (continued)

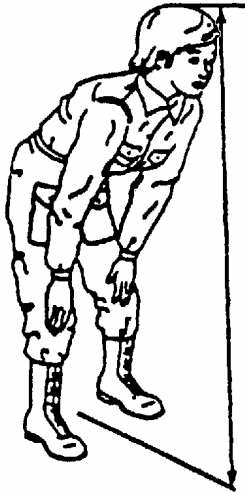

G. Bent torso height- standing with feet 30 cm (12in) apart; bending over and placing palms of the hands on kneecaps; elbows and knees locked; looking forward; head tilted as far back as possible; measured from floor to top of head.

	5th percentile		95th percentile	
	Male	Female	Male	Female
Bent torso height (cm)	125.6	112.7	149.9	138.6
(in)	49.4	44.4	59.0	54.6

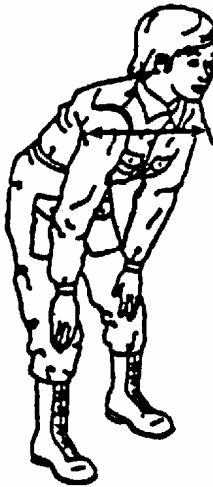

H. Bent torso breadth- standing with feet 30 cm (12 in) apart; bending over and placing the palms of the hands on kneecaps; elbows and knees locked; looking forward; head tilted as far back as possible; measured as maximum horizontal distance across shoulders.

	5th percentile		95th percentile	
	Male	Female	Male	Female
Bent torso breadth (cm)	40.9	36.8	48.3	43.5
(in)	16.1	14.5	19.0	17.1



I. Overhead reach, sitting- sitting erect; right side against wall; right arm extended upward with palm flat against wall and fingers extended; measured from sitting surface to tip of middle finger.

	5th percentile		95th percentile	
	Male	Female	Male	Female
Overhead reach sitting (cm)	127.9	117.4	146.9	139.4
(in)	50.3	46.2	57.9	54.9

Anthropometric data for common working positions (continued)

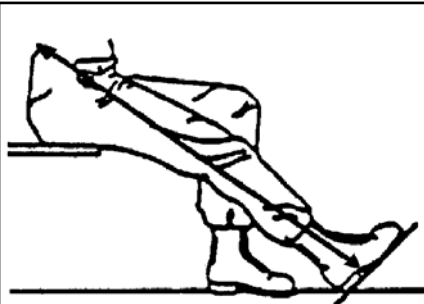

J. Function leg length- sitting erect on edge of chair; right leg extended forward with knee straightened; measured from heel along axis of leg to posterior waist.

	5th percentile		95th percentile	
	Male	Female	Male	Female
Functional leg length (cm)	110.6	90.6	127.7	118.6
(in)	43.5	35.7	50.3	46.7

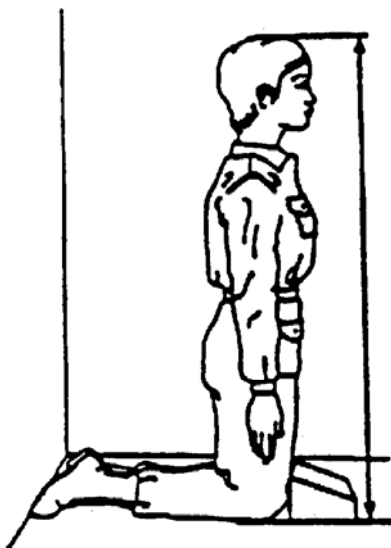

K. Kneeling height- kneeling with toes extended and lightly touching rear wall; torso erect with arms hanging loosely at sides; measured from floor to top of head.

	5th percentile		95th percentile	
	Male	Female	Male	Female
Kneeling height (cm)	121.9	114.5	136.9	130.3
(in)	48.0	45.1	53.9	51.3

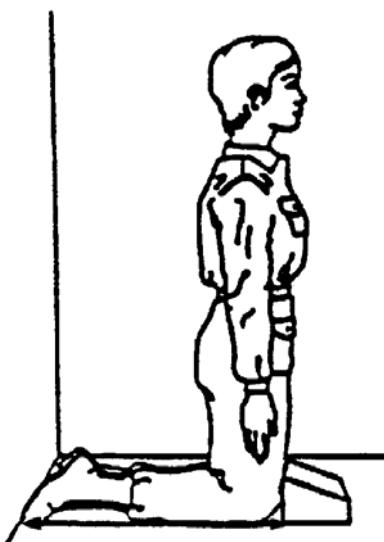

L. Kneeling leg length- kneeling with toes extended and lightly touching rear wall; torso erect with arms hanging loosely at sides; measured from wall to anterior portion of both knees.

	5th percentile		95th percentile	
	Male	Female	Male	Female
Kneeling leg length (cm)	63.9	59.2	75.5	70.5
(in)	25.2	23.3	29.7	27.8

Anthropometric data for common working positions (continued)

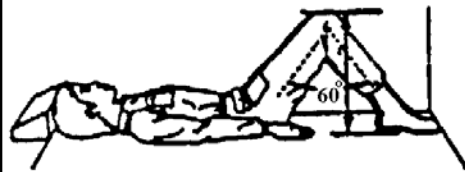

**M.** Bent knee height, supine- lying supine; knees raised until the angle between upper and lower legs approximates 60°; toes lightly touching wall; measured from floor to highest point on knees.

	5th percentile		95th percentile	
	Male	Female	Male	Female
Bent knee height (cm)	44.7	41.3	53.5	49.6
(in)	17.6	16.3	21.1	19.5



**N.** Horizontal length, knees bent- lying supine; knees raised until the angle between upper and lower legs approximates 60°; toes lightly touching wall; measured from wall to top of head.

	5th percentile		95th percentile	
	Male	Female	Male	Female
Horizontal length knees bent (cm)	150.8	140.3	173.0	163.8
(in)	59.4	55.2	68.1	64.5

### Anthropometric data for common working positions (continued)

	MAXIMUM TOTAL CONSOLE HEIGHT FROM STANDING SURFACE	SUGGESTED VERTICAL DIMENSION OF PANEL (INCLUDING SILLS)	WRITING SURFACE: SHELF HEIGHT FROM STANDING SURFACE	SEAT HEIGHT FROM STANDING SURFACE AT MIDPOINT OF G	MAXIMUM CONSOLE WIDTH (NOT SHOWN)
	A	B	C	D	
1. SIT (WITH VISION OVER TOP) <sup>1</sup>	1.170 m (46 in) 1.335 m (52.5 in) 1.435 m (56.5 in)	520 mm (20.55 in) 520 mm (20.55 in) 520 mm (20.55 in)	650 mm (25.5 in) 810 mm (32 in) 910 mm (36 in)	435 mm (17 in) 595 mm (23.5 in) 695 mm (27.5 in)	1.120 m (44 in) 1.120 m (44 in) 1.120 m (44 in)
2. SIT (WITHOUT VISION OVER TOP)	1.310 m (51.5 in) 1.470 m (58.0 in) 1.570 m (62.0 in)	660 mm (26 in) 660 mm (26 in) 660 mm (26 in)	650 mm (25.5 in) 810 mm (32 in) 910 mm (36 in)	435 mm (17 in) 595 mm (23.5 in) 695 mm (27.5 in)	910 mm (36 in) 910 mm (36 in) 910 mm (36 in)
3. SIT-STAND (WITH STANDING VISION OVER TOP)	1.535 m (60.5 in)	620 mm (24.5 in)	910 mm (36 in)	695 mm (27.5 in)	910 mm (36 in)
4. STAND (WITH VISION OVER TOP)	1.535 m (60.5 in)	620 mm (24.5 in)	910 mm (36 in)	NA	1.120 m (44 in)
5. STAND (WITHOUT VISION OVER TOP)	1.830 m (72 in)	910 mm (36 in)	910 mm (36 in)	NA	910 mm (36 in)

<sup>1</sup>THE RANGE IN "A" IS PROVIDED TO ALLOW LATITUDE IN THE VOLUME OF THE LOWER PART OF THE CONSOLE: NOTE  
RELATIONSHIP TO "C" AND "D".

## Standard console dimensions

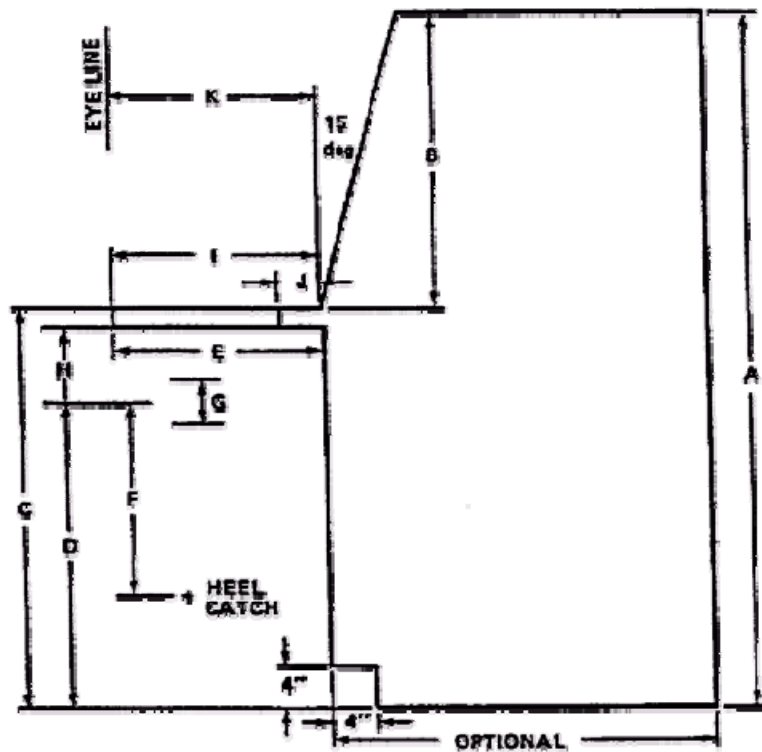

KEY	DIMENSIONS	mm	(in.)
A	MAXIMUM TOTAL CONSOLE HEIGHT FROM STANDING SURFACE		
B	SUGGESTED VERTICAL DIMENSION OF PANEL, INCL SILLS	SEE TABLE IV	SEE TABLE IV
C	WRITING SURFACE: SHELF HEIGHT FROM STANDING SURFACE		
D	SEAT HEIGHT FROM STANDING SURFACE AT MIDPOINT OF "G"		
E*	MINIMUM KNEE CLEARANCE	(460)	18
F*	FOOT SUPPORT TO SITTING SURFACE**	(460)	18
G*	SEAT ADJUSTABILITY	(150)	6
H*	MINIMUM THIGH CLEARANCE AT MIDPOINT OF "G"	(190)	7.5
I	WRITING SURFACE DEPTH INCLUDING SHELF	(400)	16
J	MINIMUM SHELF DEPTH	(100)	4
K	EYE LINE-TO-CONSOLE FRONT DISTANCE	(400)	16

\*NOT APPLICABLE TO CONSOLE TYPES 4 AND 5 OF TABLE XIV.

\*\*SINCE THIS DIMENSION MUST NOT BE EXCEEDED, A HEEL CATCH MUST BE ADDED TO THE CHAIR IF "D" EXCEEDS 460 mm (18 in.).

NOTE: A SHELF THICKNESS OF 25 mm (1 in.) IS ASSUMED. FOR OTHER SHELF THICKNESS, SUITABLE ADJUSTMENTS SHOULD BE MADE.

### Standard console dimensions key

		Fixed (mm)	Adjustment <sup>1</sup> (mm)
<u>Chair</u>			
Armrests:	A.	Length	255
	B.	Width	50
	C.	Height	215
	D.	Separation	460
Seat:	E.	Width	405
	F.	Height	460
	G.	Depth	405
Backrest:	H.	Space	150
	I.	Height	380
	J.	Width	405
Footrests:	L.	From center	180
	M.	Width	150
	N.	Length	255
<u>Workspace</u>			<u>Minimum</u>
			<u>Preferred</u>
	O.	Kneehole depth	460
	P.	Kneehold width	510
	Q.	Kneehole height (standard office)	635
	R.	Desk to wall	810
	S.	Armrest to wall	610
	T.	Lateral work clearance	
		(1) Shoulders	585
		(2) Elbows	635
		(3) Best overall	1 m
	U.	Height of work surface	735
	V.	Width of work surface	
		(1) Elbow rest alone	100
		(2) Writing surface	305
		(3) Desk work area	
			760
			200
			405
			910

<sup>1</sup>Adjustment range. Adjustability is preferred for these dimensions.

### Seated workspace dimensions



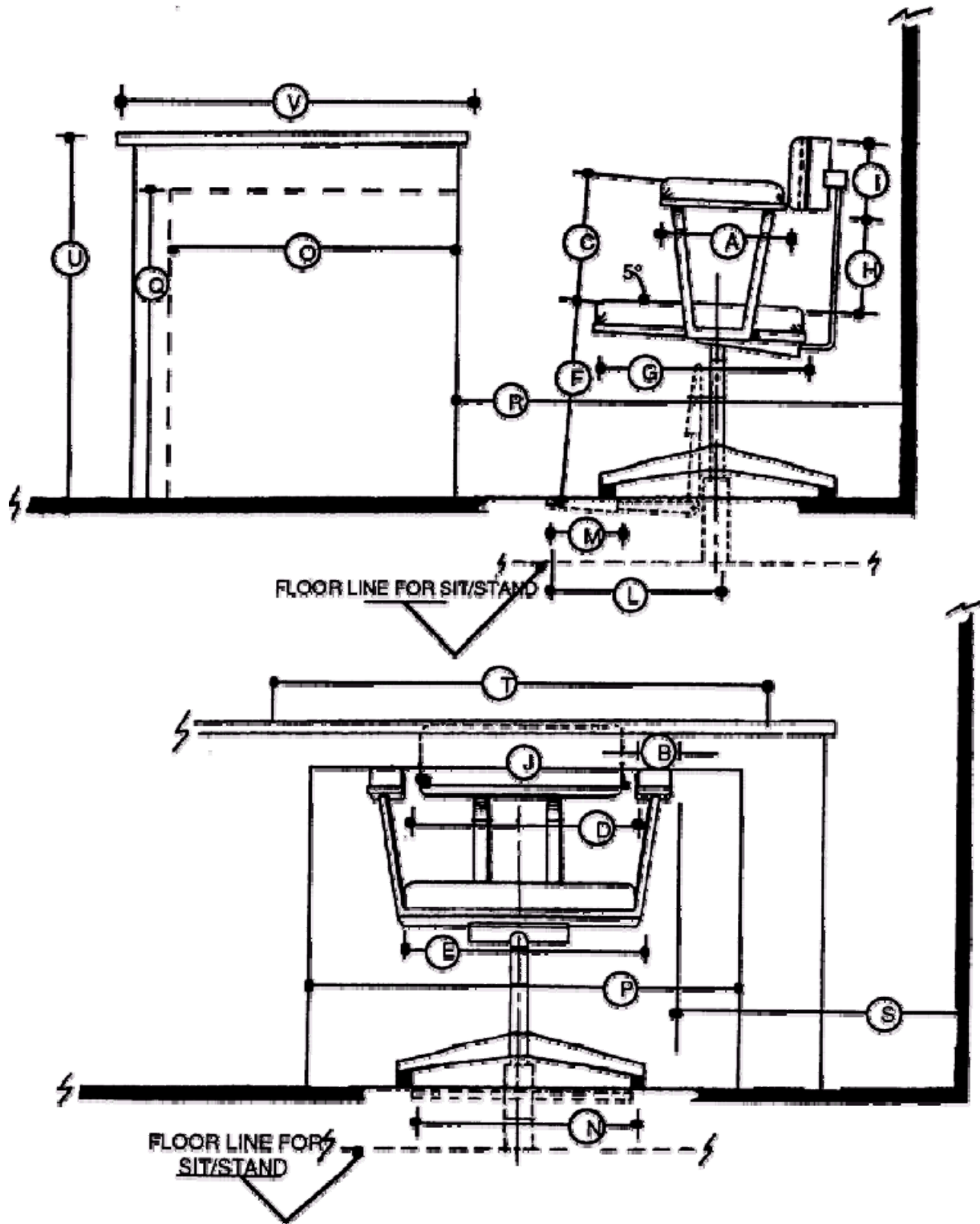

Seated workspace dimensions key

<u>Work Benches</u>			
Standard Type:	A.1 Height:	0.91 m above floor	
	B.1 Width:	0.99 m	
Podium Type:	A.2 Height:	1.04 m above floor	
	B.2 Width:	0.91 m	
<u>Work Clearances (mm)</u>	<u>Minimum</u>	<u>Preferred</u>	<u>Arctic</u>
c. Passing body depth	330	380	380
D. Standing space	760	910	
E. Foot space	100X100		
F. Overhead clearance	1855	2030	1930
G. Maximum overhead reach		685	635
H. Maximum depth of reach		585	585
I. Walking space width	305	380	380
J. Passing body width	510	810	810

### Standing workspace dimensions

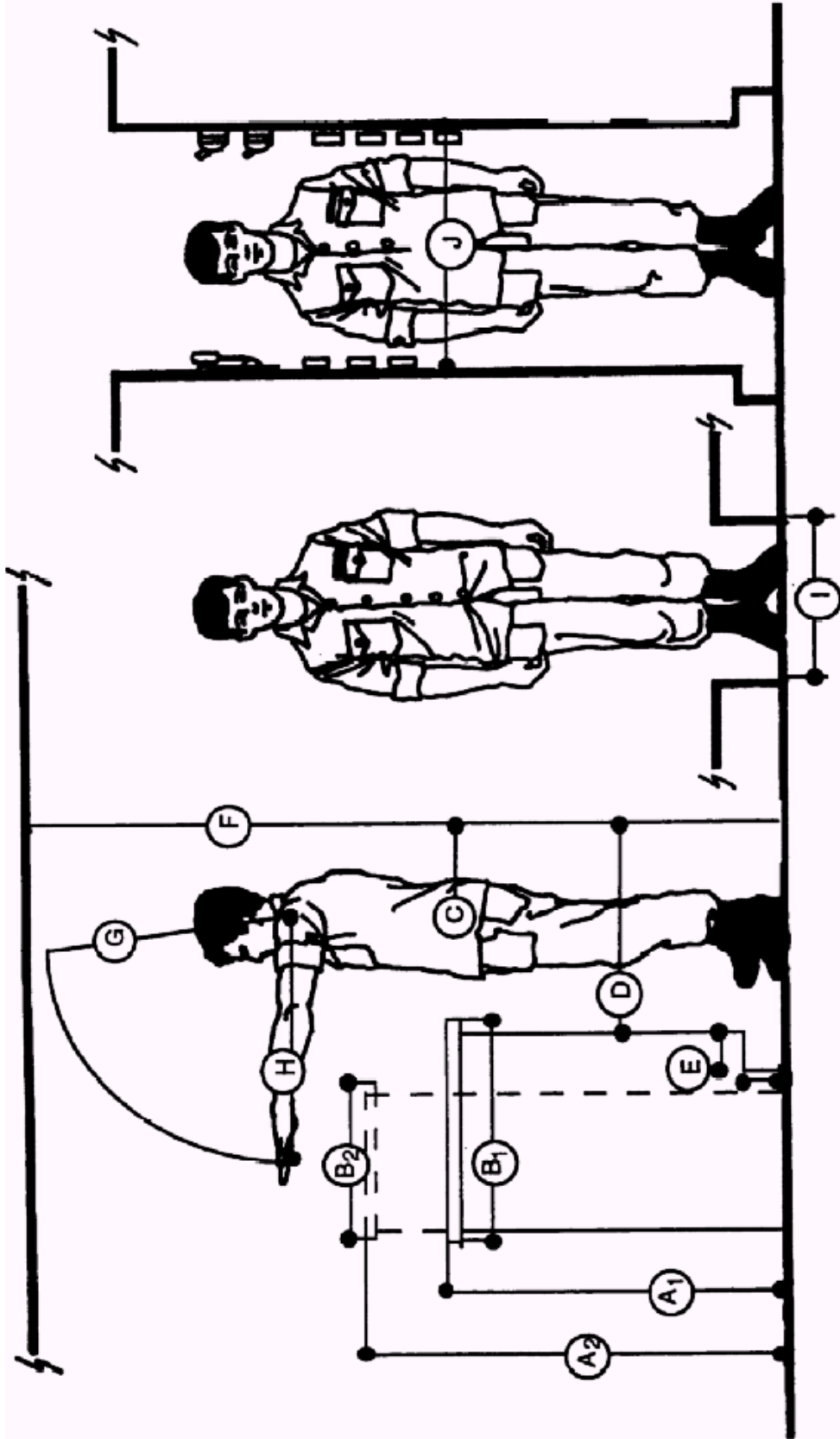

Standing workspace dimensions key

	<u>Dimensions (mm)</u>		
	Minimum	Preferred	Arctic Clothed
A. Two men passing abreast	1.06 m	1.37 m	1.53 m
B. Two men passing facing	760	910	910
Catwalk Dimensions			
C. Height	1.60 m	1.86 m	1.91 m
D. Shoulder width	560	610	810
E. Walking width	305	380	380
F. Vertical entry hatch			
Square	450	560	810
Round	560	610	
G. Horizontal entry hatch			
Shoulder width	535	610	810
Height	380	510	610
H. Crawl through pipe			
Round or square	635	760	810
Supine workspace			
I. Height	510	610	660
J. Length	1.86 m	1.91 m	1.98 m
Squatting workspace			
K. Height	1.22 m		1.29 m
L. Width	685	910	
Optimum display area	685	1.09 m	
optimum control area	485	865	
Stooping workspace			
M. Width	660	1.02 m	1.12 m
Optimum display area	810	1.22 m	
Optimum control area	610	990	
Kneeling workspace			
N. Width	1.06 m	1.22 m	1.27 m
O. Height	1.42 m		1.50 m
P. Optimum work point		685	
Optimum display area	510	890	
Optimum control area	510	890	
Kneeling crawl space			
Q. Height	785	910	965
R. Length	1.50 m		1.76 m
Prone work or crawl space			
S. Height	430	510	610
T. Length	2.86 m		

Mobile workspace dimensions

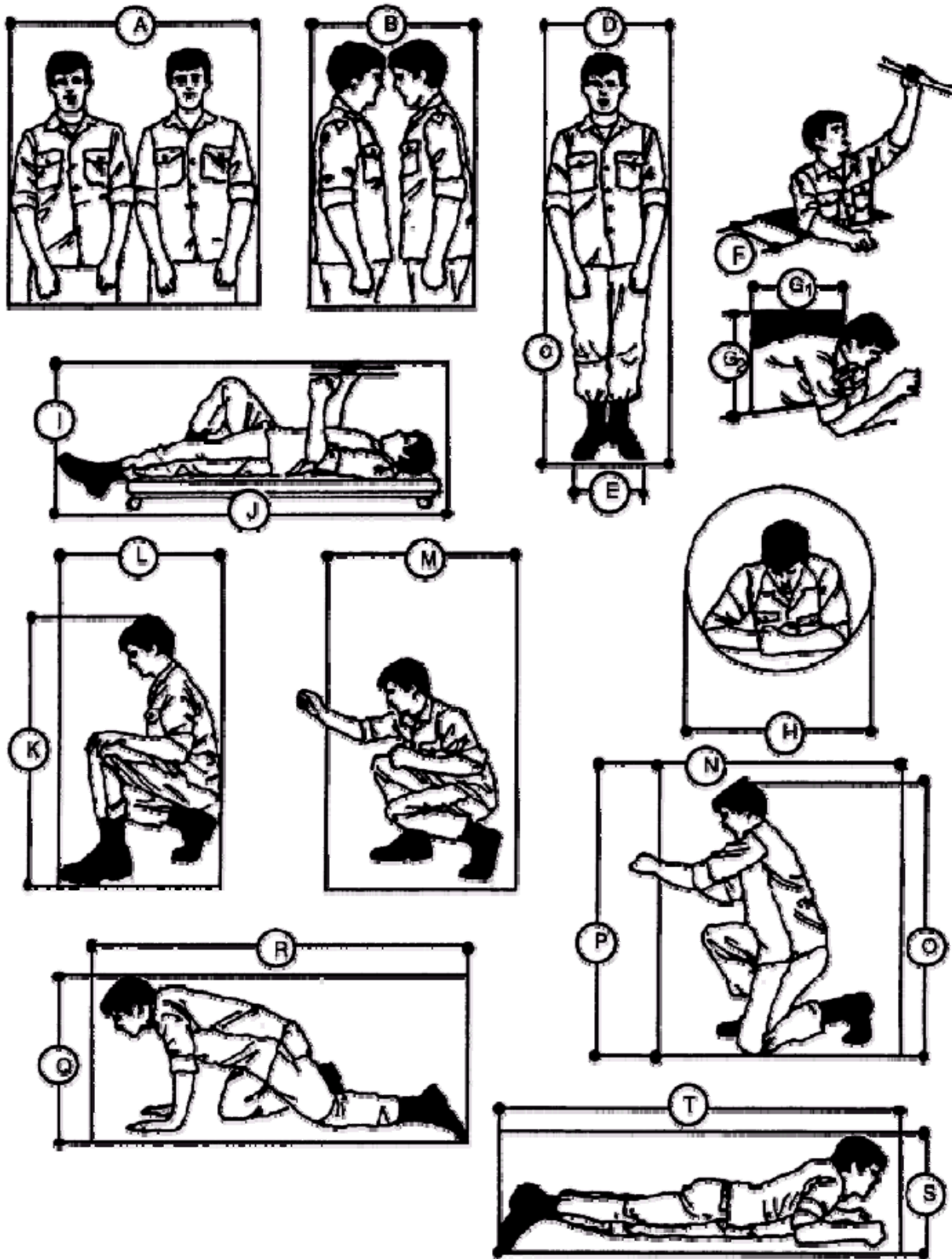

Mobile workspace dimensions key

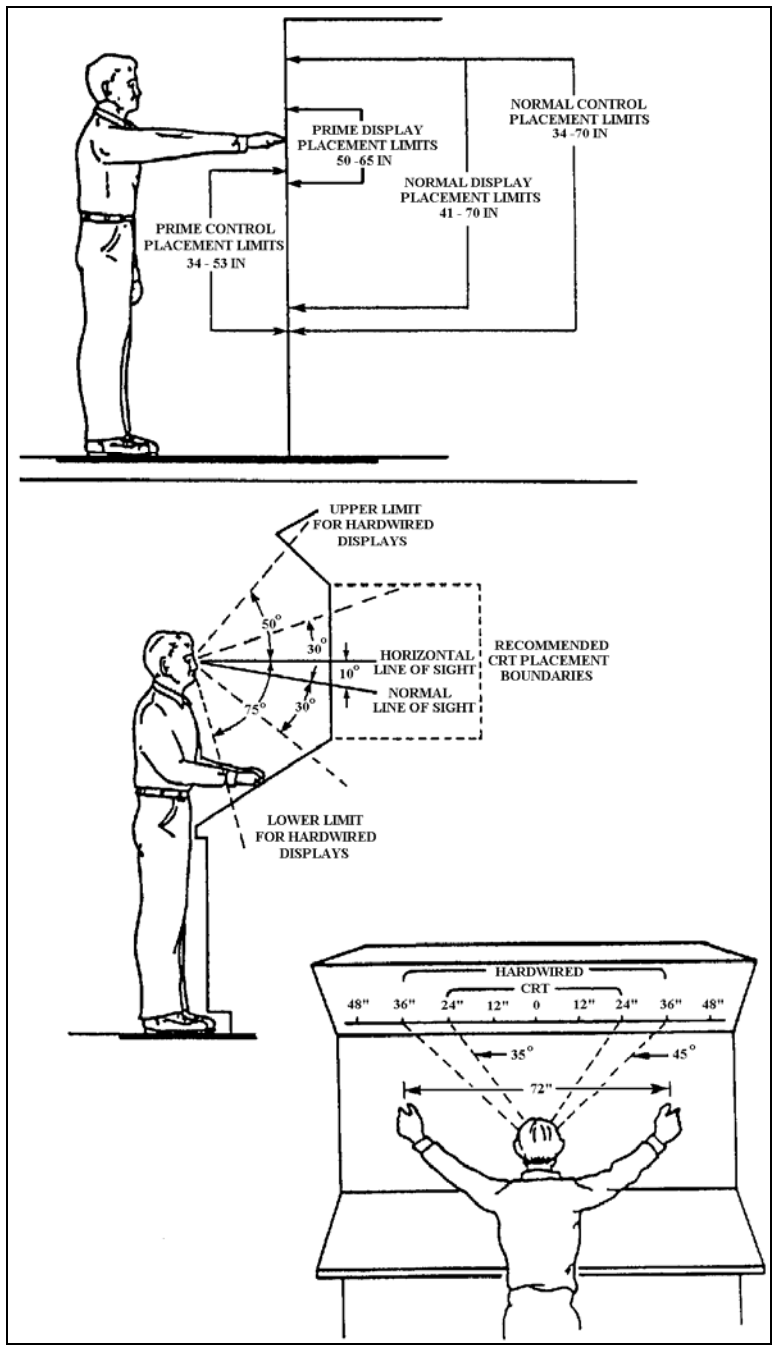

Recommended placement areas for controls and displays

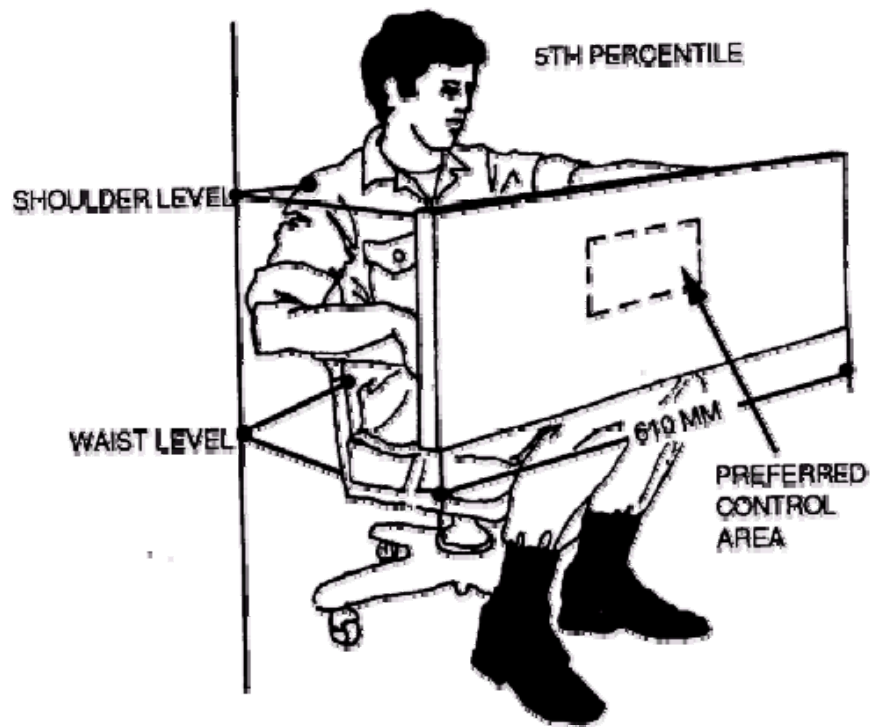
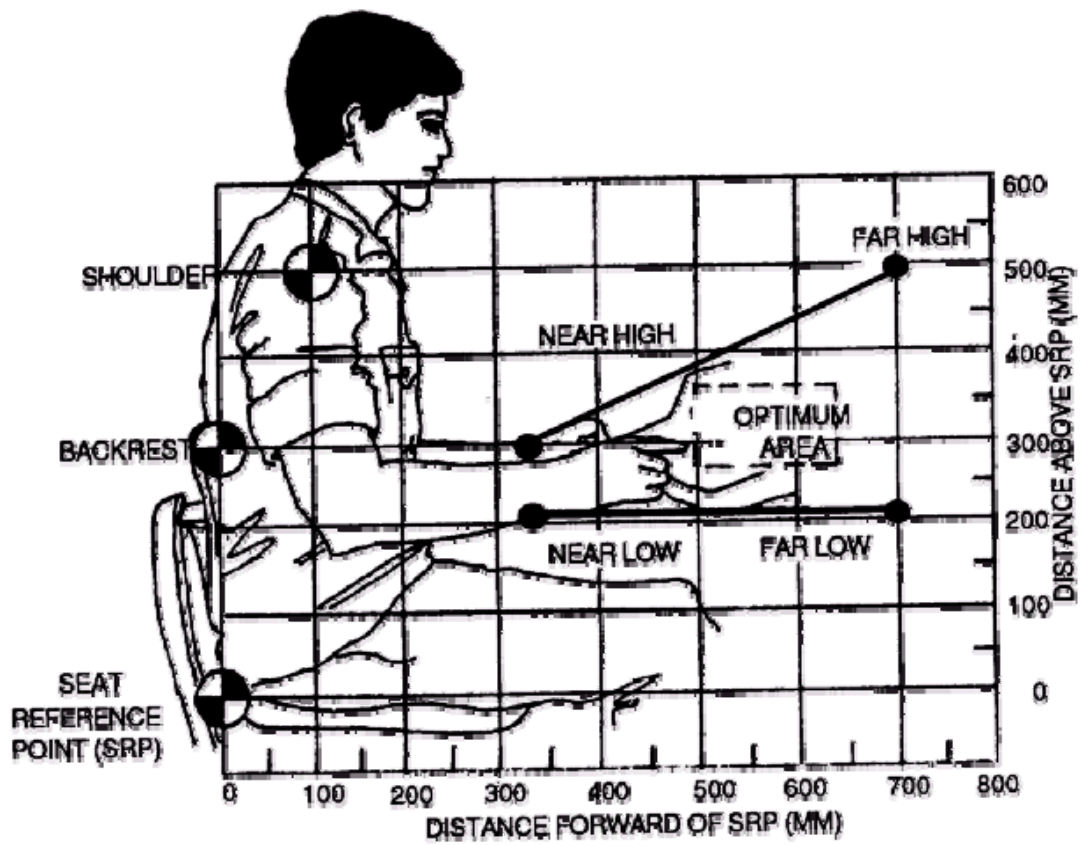

Seated optimum manual control space

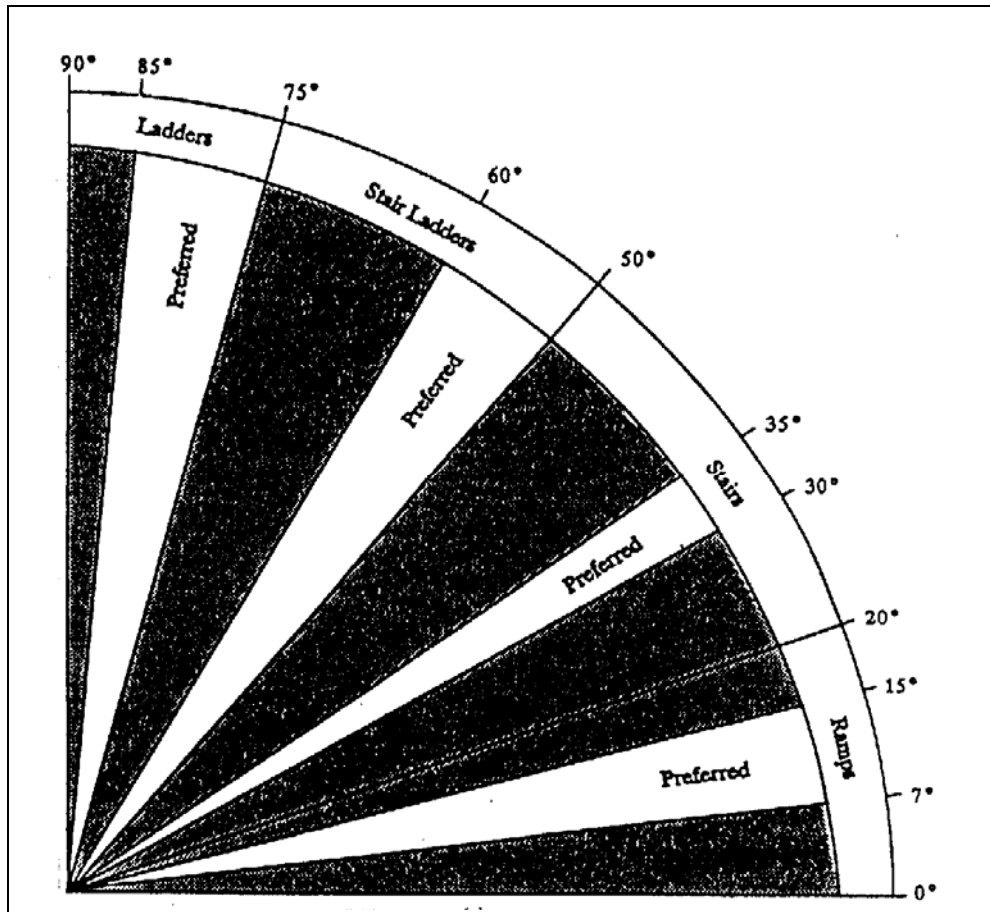

Type of structure in relation to angle of ascent



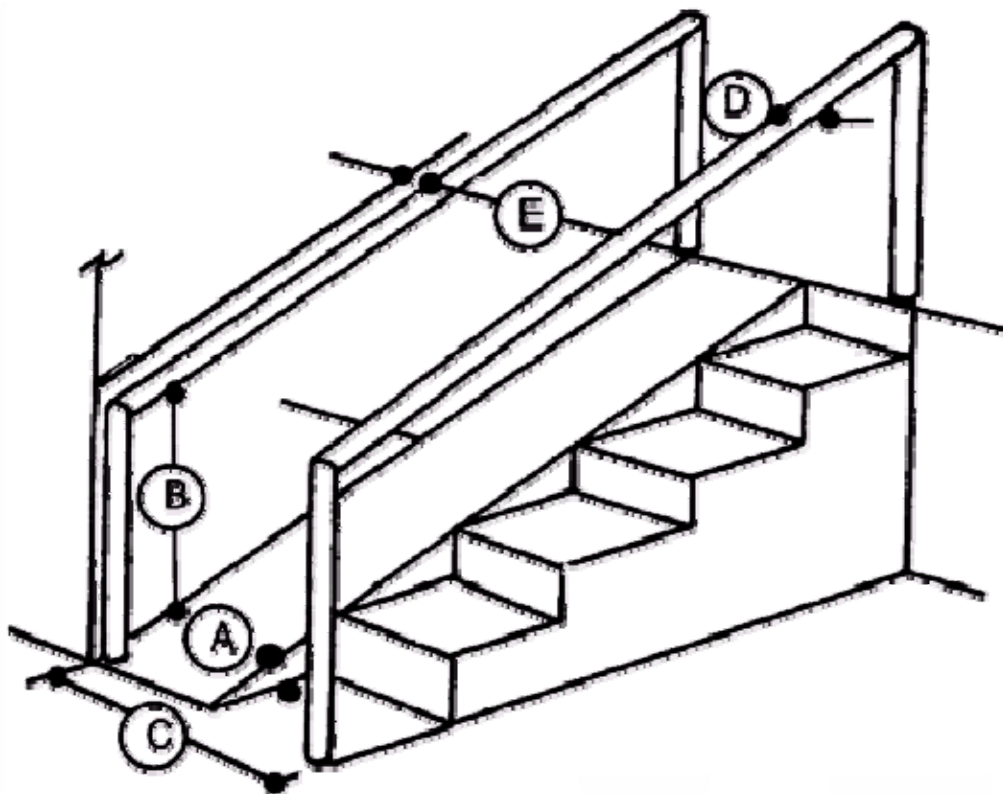

	<u>Minimum</u>	<u>Maximum</u>
A. Angle of rise:	-----	20°
B. Height of handrails:	960 mm	1.1 m
C. Width: Determined by function and usage; particularly size of rolling stock and loads .		
D. Diameter of handrail:	25 mm	75mm
E. Clearance around handrail:	50 mm	-----

### Ramp dimensions

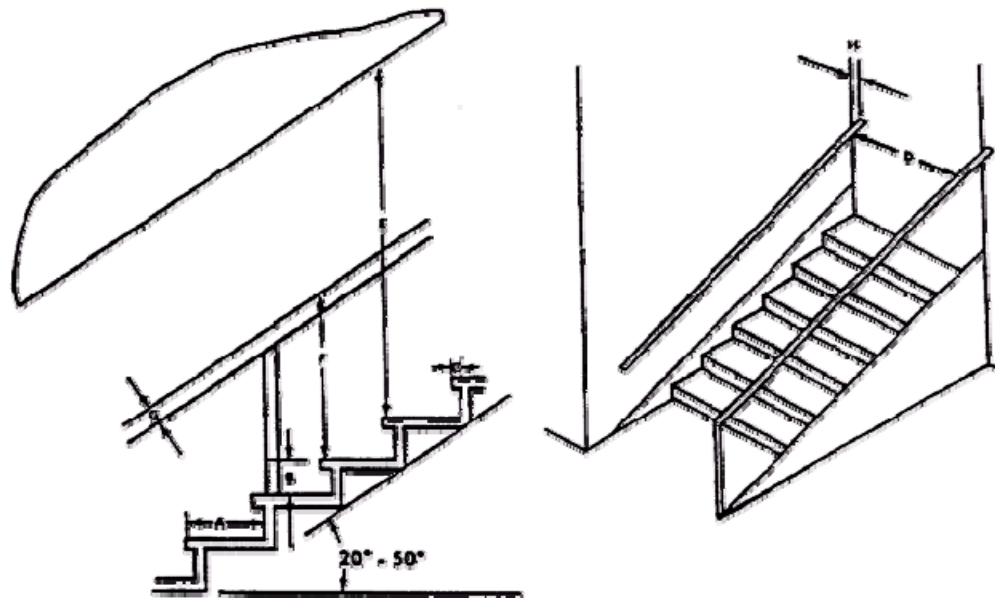

DIMENSION	MINIMUM	MAXIMUM	RECOMMENDED
A Tread depth (including nosing)	240mm (9.5 in.)	300 mm (12 in.)	280-300 mm (11-12 in.)
B Riser height	125 mm (5 in.)	200 mm (8 in.)	165-180 mm (6.5-7 in.)
C Depth of nosing (where applicable)	19 mm (0.75 in.)	38 mm (1.5 in.)	25 mm (1 in.)
D Width (handrail to handrail):			
One-way stairs	760 mm (30 in.)	---	910 mm (36 in.)
Two-way stairs	1220 mm (48 in.)	---	1300 mm (51 in.)
E Overhead clearance	1930 mm (76 in.)	---	1980 mm (78 in.)
F Height of handrail (from leading edge of tread)	840 mm (33 in.)	940 mm (37 in.)	840 mm (33 in.)
G Handrail diameter	32 mm (1.125 in.)	75 mm (3 in.)	38 mm (1.5 in.)
H Rail clearance from wall	45 mm (1.75 in.)	---	75 mm (3 in.)

## Stair dimensions

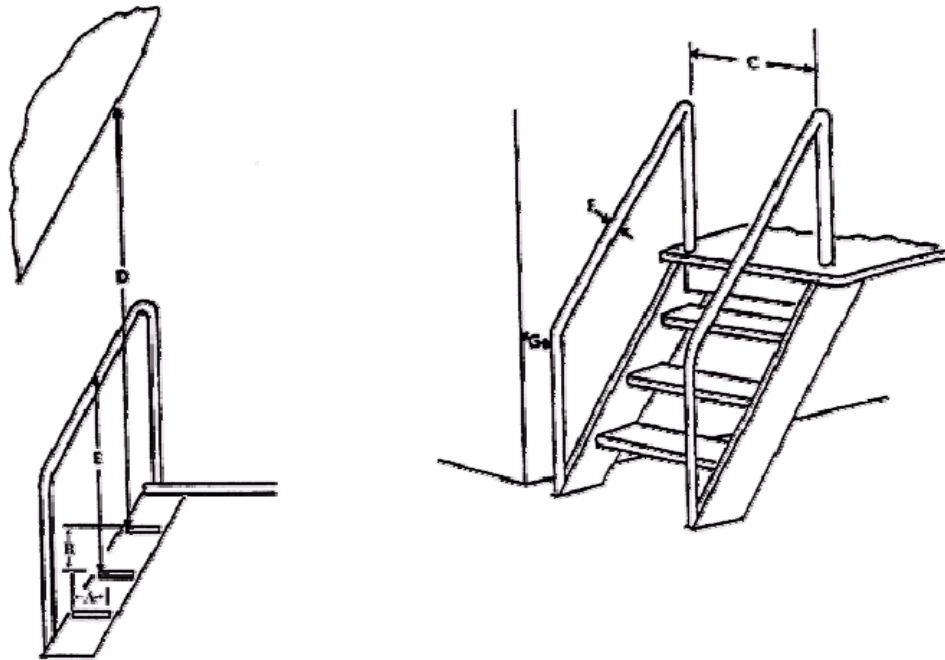

DIMENSION	MINIMUM	MAXIMUM	RECOMMENDED
A Tread depth range:			
For 50° rise	150 mm (6 in.)	250 mm (10 in.)	215 mm (8.5 in.)
For 75° rise (open ladders only)	75 mm (3 in.)	140 mm (5.5 in.)	100 mm (4 in.)
B Riser height	180 mm (7 in.)	300 mm (12 in.)	230 mm (9 in.)
C Width (handrail to handrail)	530 mm (21 in.)	610 mm (24 in.)	560 mm (22 in.)
D Overhead clearance	1730 mm* (68 in.)	---	1930 mm (78 in.)
E Height of handrail (from leading edge of tread)	860 mm (34 in.)	940 mm (37 in.)	890 mm (35 in.)
F Handrail diameter	32 mm (1.125 in.)	75 mm (3 in.)	38 mm (1.5 in.)
G Rail clearance from wall	50 mm (2 in.)	---	75 mm (3 in.)

\* Whenever the distance D is less than 1,880 mm (74 in.), the overhead obstruction should be painted with yellow and black stripes.

## Stair-ladder dimensions

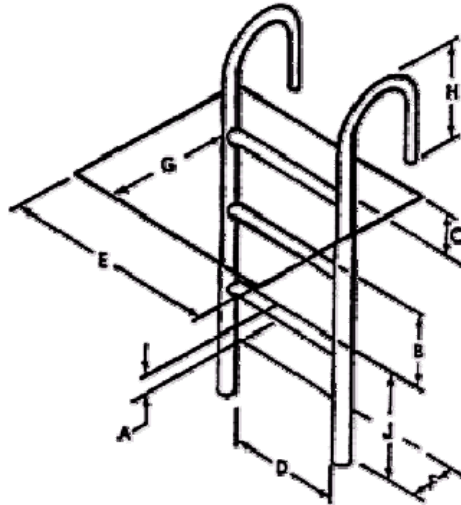

DIMENSION	MINIMUM	MAXIMUM	RECOMMENDED
A Rung thickness:			
Wood	32 mm (1.125 in.)	38 mm (1.5 in.)	35 mm (1.375 in.)
Protected metal	19 mm (0.75 in.)	38 mm (1.5 in.)	35 mm (1.375 in.)
Corrosive metal	25 mm (1 in.)	38 mm (1.5 in.)	35 mm (1.375 in.)
B Rung spacing	230 mm (9 in.)	380 mm (15 in.)	300 mm (12 in.)
C Height, rung to landing	150 mm (6 in.)	380 mm (15 in.)	380 mm (15 in.)
D Width between stringers	300 mm (12 in.)	---	460-530 mm (18-21 in.)
E Climbing clearance with Clearance depth:	610 mm (24 in.)	---	760 mm (30 in.)
F In back of ladder	150 mm (6 in.)	---	200 mm (8 in.)
G On climbing side (range)	910 mm (36 in.) for 75° to 760 mm (30 in.) for 90°		
H Height of stringer above landing	840 mm (33 in.)	---	910 mm (36 in.)
J Height from lower elevation to bottom rung		380 mm (15 in.)	

## Fixed-ladder dimensions

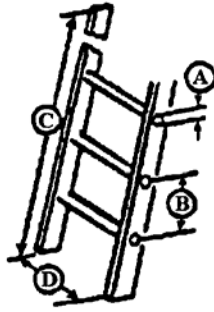

	Min	Max	Best
A Rung diameter			
wood	3 cm (1.13 in)	4 cm (1.5 in)	4 cm (1.4 in)
protected metal	2 cm (0.75 in)	4 cm (1.5 in)	4 cm (1.4 in)
metal that may rust	3 cm (1.0 in)	4 cm (1.5 in)	4 cm (1.4 in)
B Rung spacing	30 cm (12 in)	30 cm (12 in)	30 cm (12 in)
C Maximum ladder length			
single section ladder		9.1 m (30 ft)	
two-section metal ladder		14.6 m (48 ft)	
over two-section wood ladder		18.3 m (60 ft)	
D Minimum width between side rails			
metal ladders	30 cm (12 in)		
wood ladders			
up to 3.0 m (10 ft)	29 cm (11.5 in)		
add .64 cm (.25 in)			
for each added 61 cm (24 in) of length			

## Portable rung-ladder dimensions

- A. Height of cage from base of ladder: 2.1 m
- B. Flare at bottom of cage: 810 mm
- c. Depth of cage from center of ladder: 710 mm
- D. Max. distance between cage ribs : 460 mm
- E. Width of cage: 680 mm
- F. Rung diameter: See fixed ladders
- G. Rung spacing: See fixed ladders
- H. Maximum ladder length:
  - Single ladders: 9.1 m
  - Two-section metal ladders: 14.6 m
  - Two-section wood ladders: 18.3 m
- I. Min. width between siderails:
  - Metal ladders: 300 mm
  - Wood ladders up to 3 m long: 290 mm

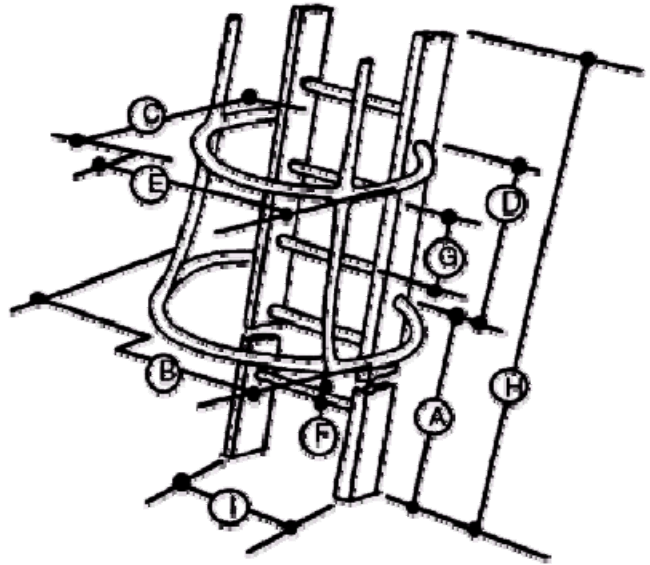

(Add 6 mm for each additional 610 mm in length.)

### Rung-ladder and ladder-cage dimensions

- A. Spread: 290 mm per meter length of front section plus 160 mm per length of back section
- B. Tread depth: Min. 75 mm; best 75 - 100 mm
- C. Step spacing: min. 230 mm; best 280 - 300 mm
- D. Min. width between top of siderails:
  - Metal ladders: 300 mm
  - Wood ladders: 290 mm
- E. Width at bottom: Add 90 mm per meter of length
- F. Length of ladder: Maximum of 6 m

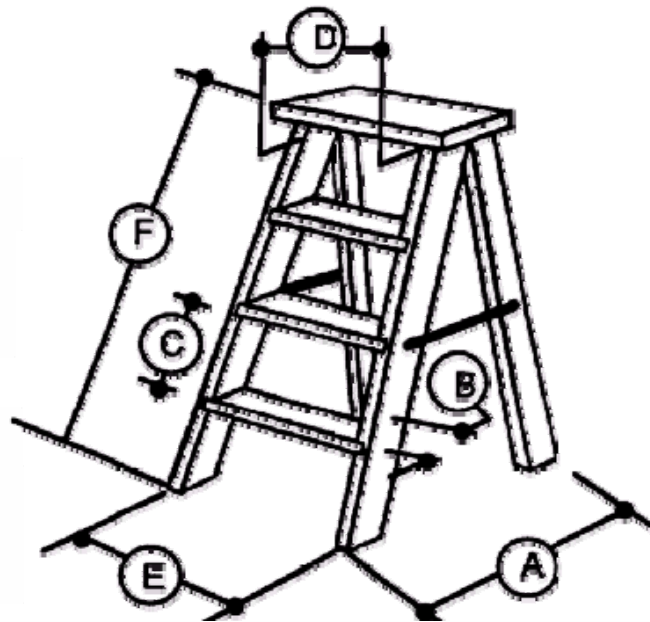

Stepladder dimensions

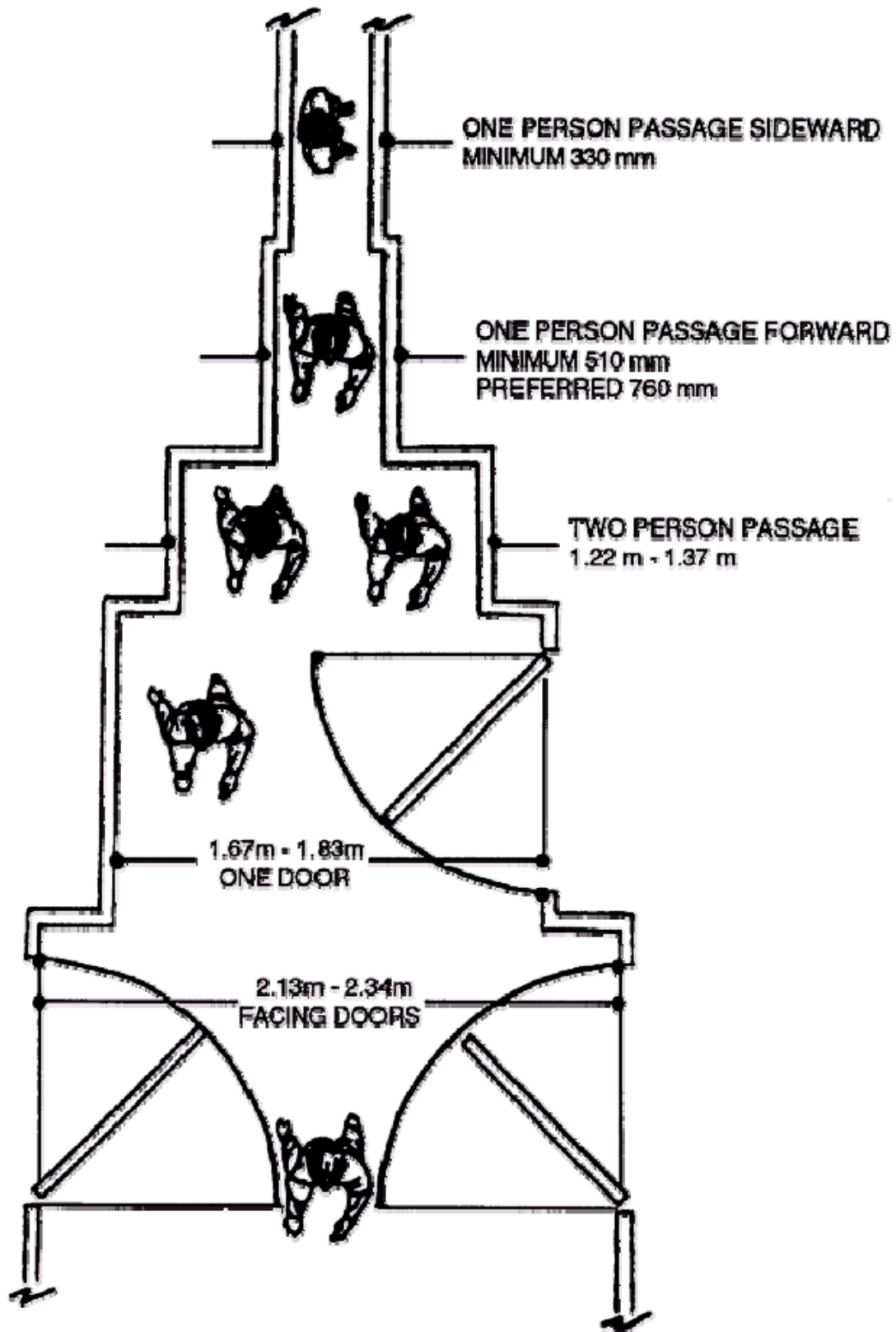

Walkway and passageway dimensions



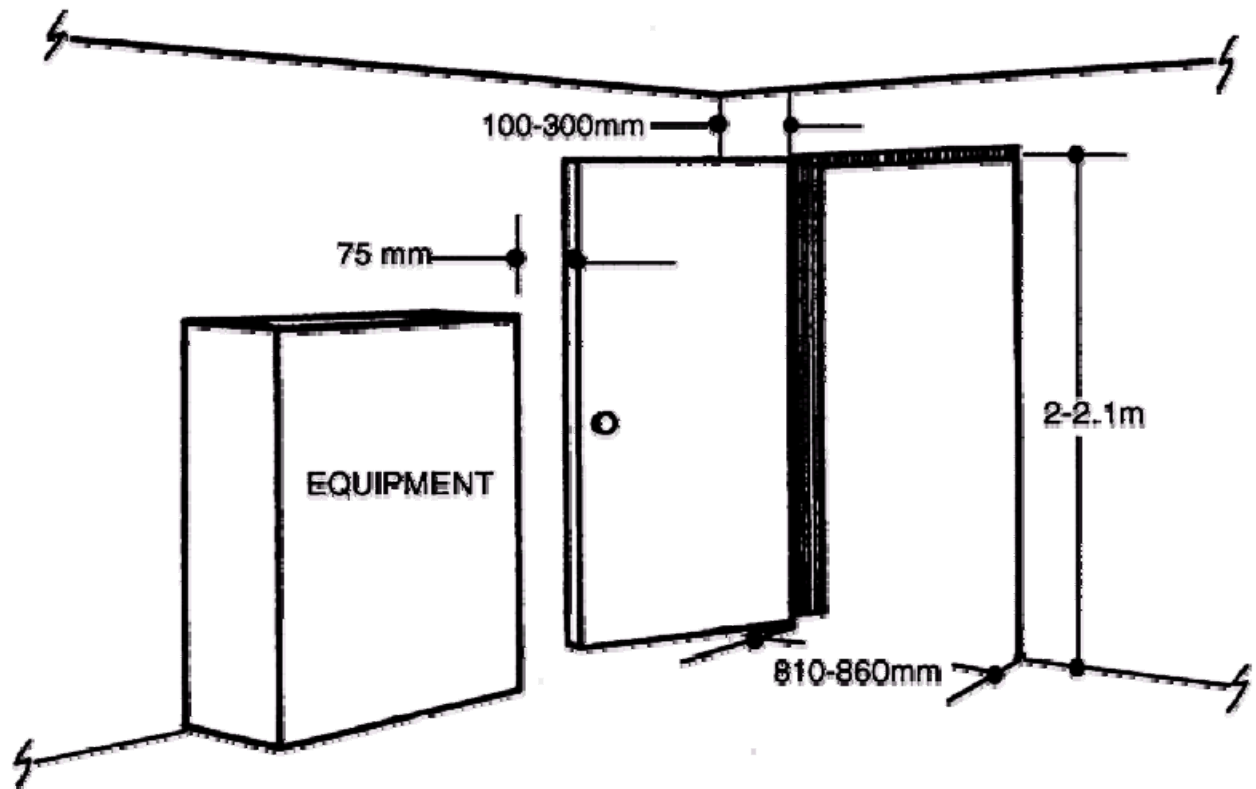

Door dimensions

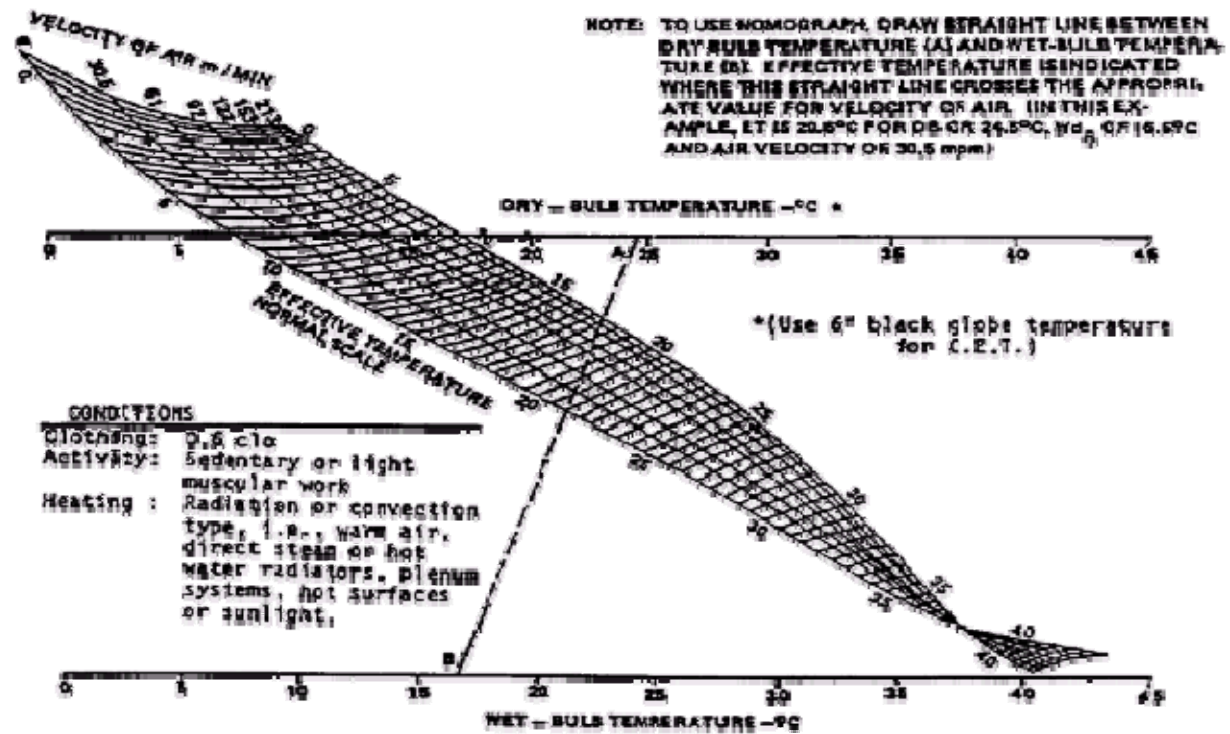

Effective temperature or corrected effective temperature



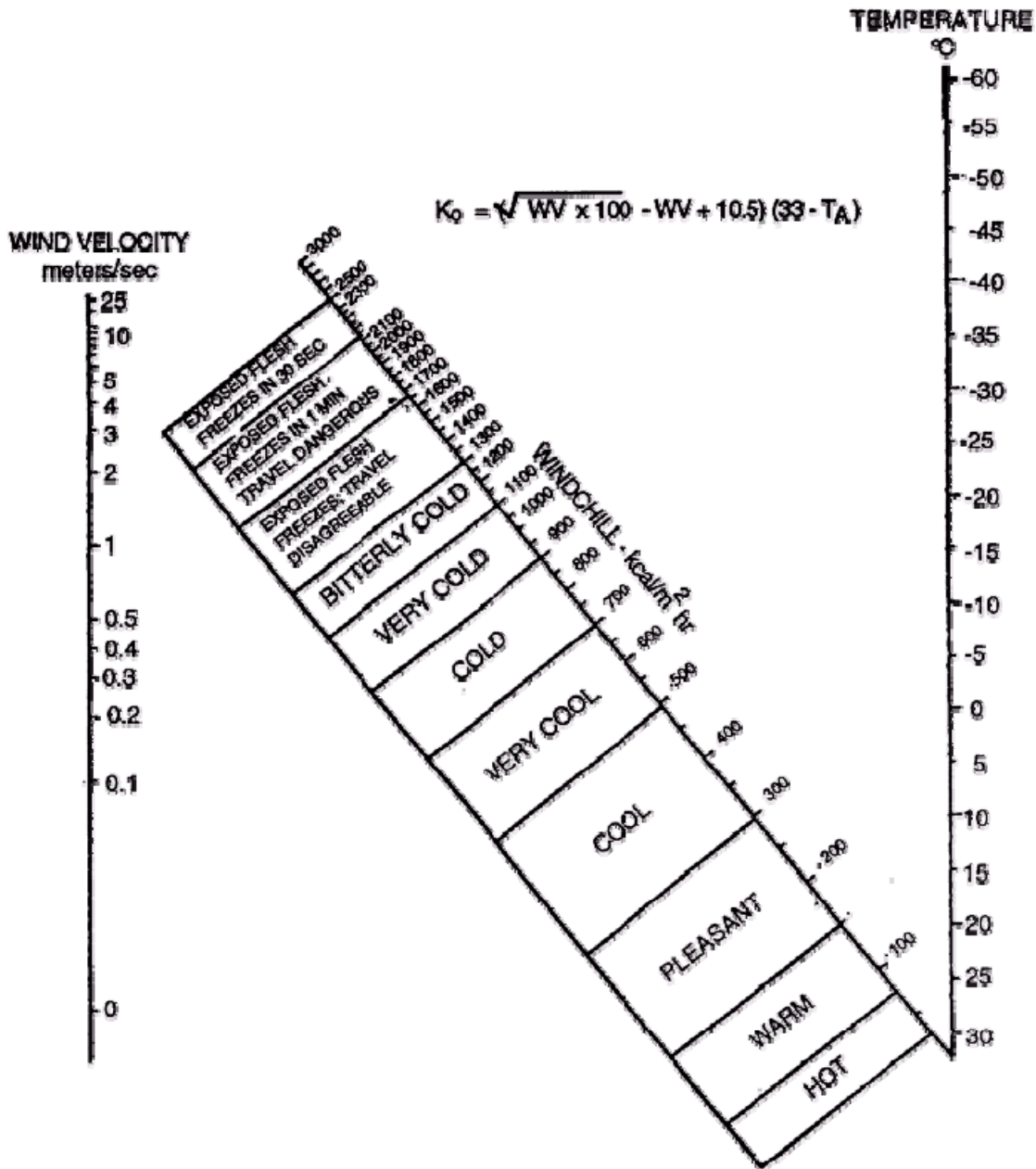

In outdoor cold weather, the wind velocity has a profound, sometimes decisive, effect on the hazard to men who are exposed. The windchill concept dramatizes this by providing a means of quantitative comparison of various combinations of temperature and wind speed. Note for example that  $-45^{\circ}\text{C}$  with an air movement of  $0.045\text{ m/s}$  has the same windchill value, and therefore is predicated to produce same sensation on exposed skin as  $-8^{\circ}\text{C}$  with a wind of only  $0.45\text{ m/s}$  or  $-10^{\circ}\text{C}$  with a wind of  $2.2\text{ m/s}$ . The windchill index does not account for physiological adaptation or adjustments. It is based on field measurements of the rate of cooling of a container of water by Paul Siple during World War II.

Windchill chart



Windchill Value	Human Reaction
100	warm
200	Pleasant
800	Cold
1000	Very Cold
1200	Bitterly Cold
1400	Exposed Flesh Freezes

### Human reaction to windchill

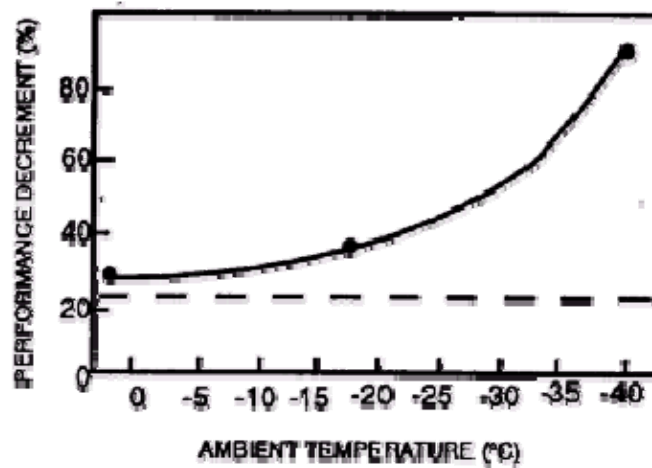

Performance decrement at different ambient temperatures

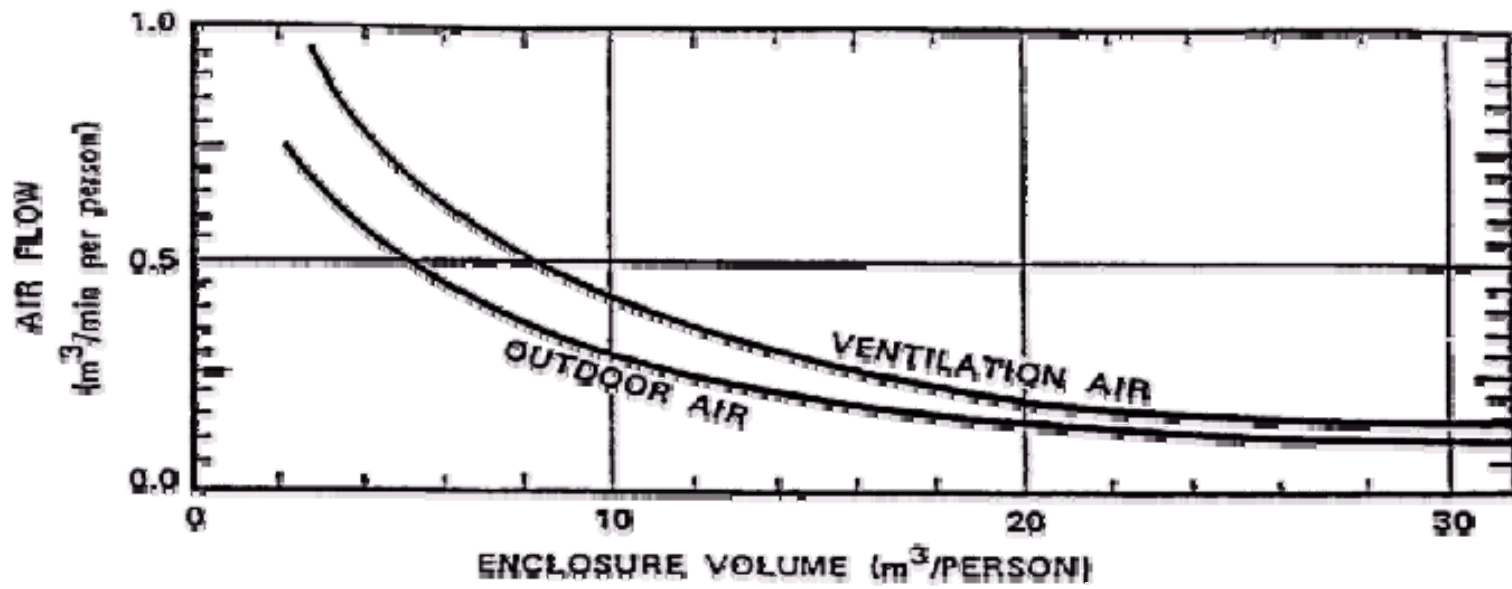

Ventilation requirements

Work area of type of task	Illumination Levels	
	lux (foot-candles) <sup>1</sup>	
	Recommended	Minimum
Assembly, missile component	1075 (100)	540 (50)
Assembly, general		
Coarse	540 (50)	325 (30)
Medium	810 (75)	540 (50)
Fine	1075 (100)	810 (75)
Precise	3230 (300)	2155 (200)
Bench work		
Rough	540 (50)	325 (30)
Medium	810 (75)	540 (50)
Fine	1615 (150)	1075 (100)
extra fine	3230 (300)	2155 (200)
Bomb shelters and mobile shelters, when used for rest and relief	20 (2)	10 (1)
Business machine operation (calculator, digital input, etc.)	1075 (100)	540 (50)
Console surface	540 (50)	325 (30)
Corridors	215 (20)	110 (10)
Circuit diagram	1075 (100)	540 (50)
Dials	540 (50)	325 (30)
Electrical equipment testing	540 (50)	325 (30)
Emergency lighting	NA	30 (3)
Gages	540 (50)	325 (30)
Hallways	215 (20)	110 (10)
Inspection tasks, general		
Rough	540 (50)	325 (30)
Medium	1075 (100)	540 (50)
Fine	2155 (200)	1075 (100)
extra fine	3230 (300)	2155 (200)
Machine operation, automatic	540 (50)	325 (30)
Meters	540 (50)	325 (30)
Missiles:		
repair and servicing	1075 (100)	540 (50)
storage areas	215 (20)	110 (10)
general inspection	540 (50)	325 (30)

## Specific task illumination requirements



Work area of type of task	Recommended	lux (foot-candles) <sup>1</sup>
		Minimum
Office work, general	755 (70)	540 (50)
Ordinary seeing tasks	540 (50)	325 (30)
Panels:		
Front	540 (50)	325 (30)
Rear	325 (30)	110 (10)
Passageways	215 (20)	110 (10)
Reading:		
large print	325 (30)	110 (10)
newsprint	540 (50)	325 (30)
handwritten reports, in pencil	755 (70)	540 (50)
small type	755 (70)	540 (50)
prolonged reading	755 (70)	540 (50)
Recording	755 (70)	540 (50)
Repair work:		
General	540 (50)	325 (30)
Instrument	2155 (200)	1075 (100)
Scales	540 (50)	325 (30)
Screw fastening	540 (50)	325 (30)
Service areas, general:	215 (20)	110 (10)
Stairways	215 (20)	110 (10)
Storage:		
inactive or dead	55 (5)	30 (3)
general warehouse	110 (10)	55 (5)
live, rough or bulk	110 (10)	55 (5)
live, medium	325 (30)	215 (20)
live, fine	540 (50)	325 (30)
Switchboards	540 (50)	325 (30)
Tanks, containers	215 (20)	110 (10)
Testing:		
Rough	540 (50)	325 (30)
Fine	1075 (100)	540 (50)
extra fine	2155 (200)	1075 (100)
Transcribing and tabulation	1075 (100)	540 (50)
<sup>1</sup> As measured at the task object or 76 cm (30 in) above the floor. Note: As a guide in determining illumination requirements the use of a steel scale with 1/64 inch divisions requires 1950 lux (180 foot-candles) of light for optimum visibility.		

### Specific task illumination requirements (continued)

Condition of use	Lighting Technique <sup>1</sup>	Brightness of markings cd/m <sup>2</sup> (footlamberts)	Brightness Adjustment
Indicator reading, dark adaptation necessary	Red flood, indirect, or both, with operator choice	0.07–0.35 (0.02–0.1)	Continuous throughout range
Indicator reading, dark adaptation not necessary but desirable	Red or low-color-temperature white flood, indirect, or both, with operator choice	0.07–0.35 (0.02–1.0)	Continuous throughout range
Indicator reading, dark adaptation not necessary	White flood	3.5-70 (1-20)	Fixed or continuous
Panel monitoring, dark adaptation necessary	Red edge lighting, red or white flood, or both, with operator choice	0.07–3.5 (0.02–1.0)	Continuous throughout range
Panel monitoring, dark adaptation not necessary	White flood	35-70 (10–20)	Fixed or continuous
Possible exposure to bright flashes, restricted daylight	White flood	35-70 (10–20)	Fixed
Chart reading, dark adaptation necessary	Red or white flood with operator choice	0.35–3.50 (0.1–1.0)	Continuous throughout range
Chart reading, dark adaptation not necessary	White flood	17–70 (5–20)	Fixed or continuous

<sup>1</sup> Where detection of ground vehicles or other protected assets by image intensifier night vision devices must be minimized, blue-green light (incandescent filament through a filter which passes only wave lengths shorter than 600 nm) should be used in lieu of red light.

## Recommendations for display lighting

Comparison	Environmental Classification*		
	A	B	c
Between tasks and adjacent darker surroundings	3:1	3:1	5:1
Between tasks and adjacent lighter surroundings	1:3	1:3	1:5
Between tasks and more remote darker surfaces	10:1	20:1	***
Between tasks and more remote lighter surfaces	1:10	1:20	***
Between luminaries and adjacent surfaces	20:1	***	***
Between the immediate work area and the rest of the environment	40:1	***	***

- \*A Interior areas where reflection off entire space can be controlled for optimum visual conditions.
- B Areas where reflection off immediate work area can be controlled, but there is only limited control over remote surroundings.
- C Areas (indoor and outdoor) where it is impractical to control reflection and difficult to alter environmental conditions.
- \*\*\* Brightness ratio control not practical

## Brightness ratios

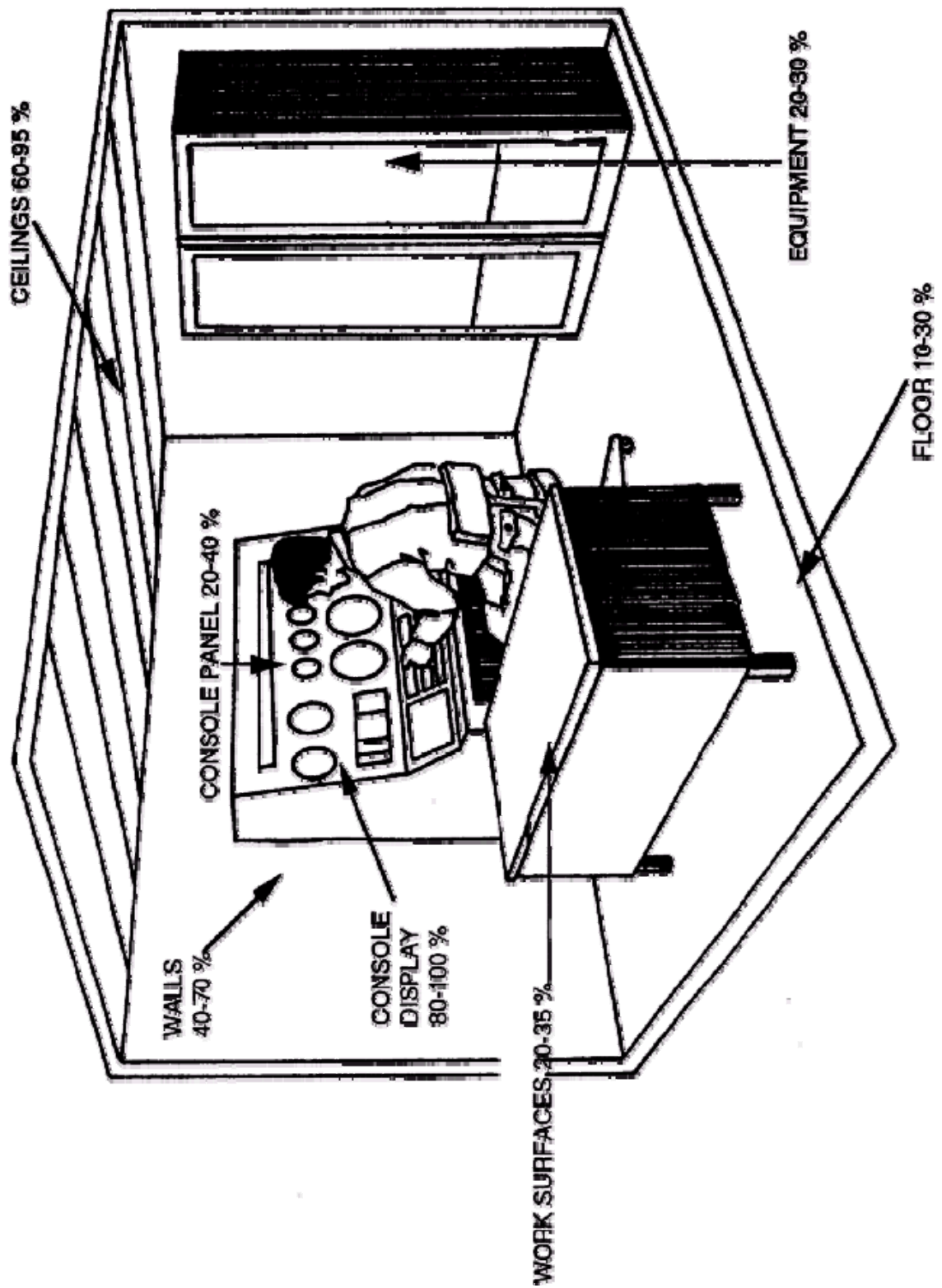



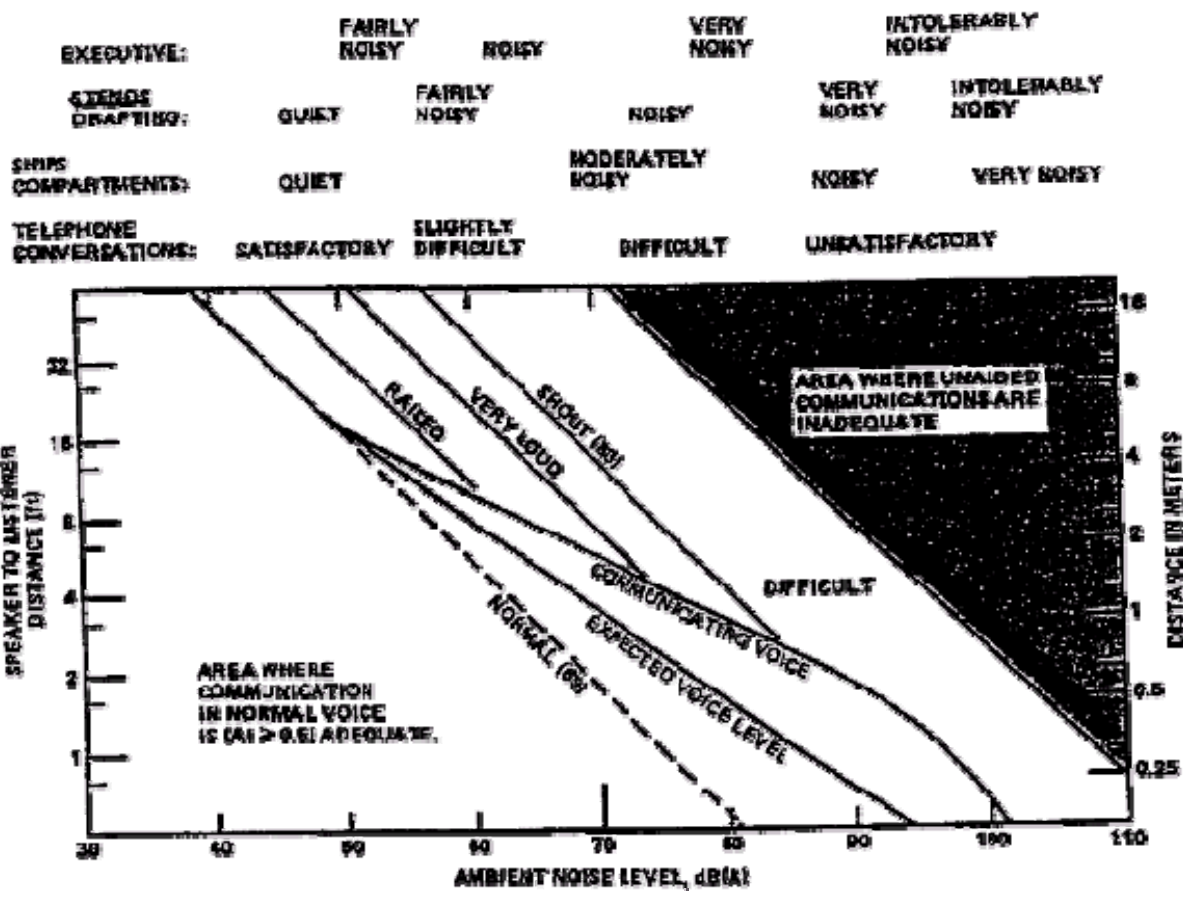



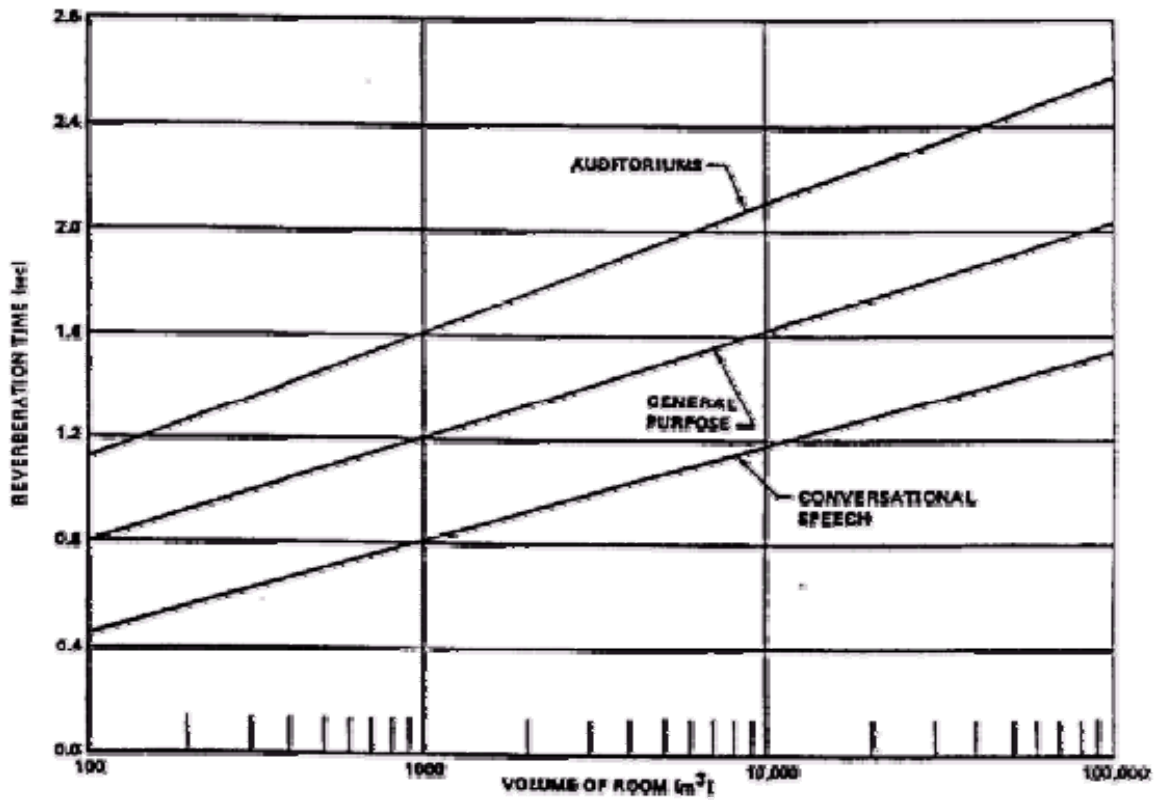



Workspace reflectance values

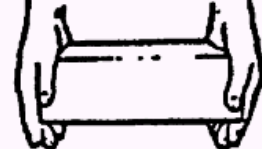

Permissible distance between a speaker and listeners

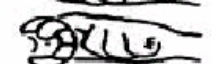

Range of acceptable reverberation time

MINIMAL TWO-HAND ACCESS OPENING WITHOUT VISUAL ACCESS																																																																																
<p>Reaching with both hands to depth of 150 to 490mm:</p> <table border="0"> <tr> <td>Light clothing:</td> <td>Width:</td> <td>200mm or the depth of reach*</td> </tr> <tr> <td></td> <td>Height:</td> <td>125mm</td> </tr> <tr> <td>Arctic clothing:</td> <td>Width:</td> <td>150mm plus 3/4 the depth of reach</td> </tr> <tr> <td></td> <td>Height:</td> <td>180mm</td> </tr> </table>		Light clothing:	Width:	200mm or the depth of reach*		Height:	125mm	Arctic clothing:	Width:	150mm plus 3/4 the depth of reach		Height:	180mm	  																																																																		
Light clothing:	Width:	200mm or the depth of reach*																																																																														
	Height:	125mm																																																																														
Arctic clothing:	Width:	150mm plus 3/4 the depth of reach																																																																														
	Height:	180mm																																																																														
<p>Reaching full arm's length (to shoulders) with both arms:</p> <table border="0"> <tr> <td></td> <td>Width:</td> <td>500mm</td> </tr> <tr> <td></td> <td>Height:</td> <td>125mm</td> </tr> </table>			Width:	500mm		Height:	125mm																																																																									
	Width:	500mm																																																																														
	Height:	125mm																																																																														
<p>Inserting box grasped by handles on the front:</p> <p>13mm clearance around box, assuming adequate clearance around handles</p>																																																																																
<p>Inserting box with hands on the sides:</p> <table border="0"> <tr> <td>Light clothing:</td> <td>Width:</td> <td>Box plus 115mm</td> </tr> <tr> <td></td> <td>+ Height:</td> <td>125mm or 13mm around box*</td> </tr> <tr> <td>Arctic clothing:</td> <td>Width:</td> <td>Box plus 180mm</td> </tr> <tr> <td></td> <td>+ Height:</td> <td>215mm or 15mm around box*</td> </tr> </table> <p>*Whichever is larger.</p> <p>+If hands curl around bottom, allow an extra 38mm for light clothing, 75mm for arctic clothing.</p>		Light clothing:	Width:	Box plus 115mm		+ Height:	125mm or 13mm around box*	Arctic clothing:	Width:	Box plus 180mm		+ Height:	215mm or 15mm around box*																																																																			
Light clothing:	Width:	Box plus 115mm																																																																														
	+ Height:	125mm or 13mm around box*																																																																														
Arctic clothing:	Width:	Box plus 180mm																																																																														
	+ Height:	215mm or 15mm around box*																																																																														
MINIMAL ONE-HAND ACCESS OPENING WITHOUT VISUAL ACCESS																																																																																
<table border="0"> <thead> <tr> <th></th> <th>Height</th> <th>Width</th> </tr> </thead> <tbody> <tr> <td colspan="3"><u>Empty hand, to wrist:</u></td> </tr> <tr> <td>Bare hand, rolled:</td> <td>95mm</td> <td>sq or dia</td> </tr> <tr> <td>Bare hand, flat:</td> <td>55mm</td> <td>x 100mm or 100mm dia</td> </tr> <tr> <td>Glove or mitten:</td> <td>100mm</td> <td>x 150mm or 150mm dia</td> </tr> <tr> <td>Arctic mitten:</td> <td>125mm</td> <td>x 165mm or 165mm dia</td> </tr> <tr> <td colspan="3"><u>Clenched hand, to wrist:</u></td> </tr> <tr> <td>Bare hand:</td> <td>95mm</td> <td>x 125mm or 125mm dia</td> </tr> <tr> <td>Glove or mitten:</td> <td>115mm</td> <td>x 150mm or 150mm dia</td> </tr> <tr> <td>Arctic mitten:</td> <td>180mm</td> <td>x 215mm or 215mm dia</td> </tr> <tr> <td colspan="3"><u>Hand plus 1" dia object, to wrist:</u></td> </tr> <tr> <td>Bare hand:</td> <td>95mm</td> <td>sq or dia</td> </tr> <tr> <td>Gloved hand:</td> <td>150mm</td> <td>sq or dia</td> </tr> <tr> <td>Arctic hand:</td> <td>180mm</td> <td>sq or dia</td> </tr> <tr> <td colspan="3"><u>Hand plus object over 1" in dia, to wrist:</u></td> </tr> <tr> <td>Bare hand:</td> <td>45mm</td> <td>clearance around object</td> </tr> <tr> <td>Glove or mitten:</td> <td>65mm</td> <td>clearance around object</td> </tr> <tr> <td>Arctic mitten:</td> <td>90mm</td> <td>clearance around object</td> </tr> <tr> <td colspan="3"><u>Arm to elbow:</u></td> </tr> <tr> <td>Light clothing:</td> <td>100mm</td> <td>x 115mm</td> </tr> <tr> <td>Arctic clothing:</td> <td>180mm</td> <td>sq or dia</td> </tr> <tr> <td>With object:</td> <td></td> <td>Clearances as above</td> </tr> <tr> <td colspan="3"><u>Arm to shoulder:</u></td> </tr> <tr> <td>Light clothing:</td> <td>125mm</td> <td>sq or dia</td> </tr> <tr> <td>Arctic clothing:</td> <td>215mm</td> <td>sq or dia</td> </tr> <tr> <td>With object:</td> <td></td> <td>Clearances as above</td> </tr> </tbody> </table>			Height	Width	<u>Empty hand, to wrist:</u>			Bare hand, rolled:	95mm	sq or dia	Bare hand, flat:	55mm	x 100mm or 100mm dia	Glove or mitten:	100mm	x 150mm or 150mm dia	Arctic mitten:	125mm	x 165mm or 165mm dia	<u>Clenched hand, to wrist:</u>			Bare hand:	95mm	x 125mm or 125mm dia	Glove or mitten:	115mm	x 150mm or 150mm dia	Arctic mitten:	180mm	x 215mm or 215mm dia	<u>Hand plus 1" dia object, to wrist:</u>			Bare hand:	95mm	sq or dia	Gloved hand:	150mm	sq or dia	Arctic hand:	180mm	sq or dia	<u>Hand plus object over 1" in dia, to wrist:</u>			Bare hand:	45mm	clearance around object	Glove or mitten:	65mm	clearance around object	Arctic mitten:	90mm	clearance around object	<u>Arm to elbow:</u>			Light clothing:	100mm	x 115mm	Arctic clothing:	180mm	sq or dia	With object:		Clearances as above	<u>Arm to shoulder:</u>			Light clothing:	125mm	sq or dia	Arctic clothing:	215mm	sq or dia	With object:		Clearances as above	     
	Height	Width																																																																														
<u>Empty hand, to wrist:</u>																																																																																
Bare hand, rolled:	95mm	sq or dia																																																																														
Bare hand, flat:	55mm	x 100mm or 100mm dia																																																																														
Glove or mitten:	100mm	x 150mm or 150mm dia																																																																														
Arctic mitten:	125mm	x 165mm or 165mm dia																																																																														
<u>Clenched hand, to wrist:</u>																																																																																
Bare hand:	95mm	x 125mm or 125mm dia																																																																														
Glove or mitten:	115mm	x 150mm or 150mm dia																																																																														
Arctic mitten:	180mm	x 215mm or 215mm dia																																																																														
<u>Hand plus 1" dia object, to wrist:</u>																																																																																
Bare hand:	95mm	sq or dia																																																																														
Gloved hand:	150mm	sq or dia																																																																														
Arctic hand:	180mm	sq or dia																																																																														
<u>Hand plus object over 1" in dia, to wrist:</u>																																																																																
Bare hand:	45mm	clearance around object																																																																														
Glove or mitten:	65mm	clearance around object																																																																														
Arctic mitten:	90mm	clearance around object																																																																														
<u>Arm to elbow:</u>																																																																																
Light clothing:	100mm	x 115mm																																																																														
Arctic clothing:	180mm	sq or dia																																																																														
With object:		Clearances as above																																																																														
<u>Arm to shoulder:</u>																																																																																
Light clothing:	125mm	sq or dia																																																																														
Arctic clothing:	215mm	sq or dia																																																																														
With object:		Clearances as above																																																																														
MINIMAL FINGER ACCESS TO FIRST JOINT																																																																																
<p><u>Push button access:</u></p> <table border="0"> <tr> <td>Bare hand:</td> <td>32mm dia</td> </tr> <tr> <td>Gloved hand:</td> <td>38mm dia</td> </tr> </table>		Bare hand:	32mm dia	Gloved hand:	38mm dia	 																																																																										
Bare hand:	32mm dia																																																																															
Gloved hand:	38mm dia																																																																															
<p><u>Two finger twist access:</u></p> <table border="0"> <tr> <td>Bare hand:</td> <td>object plus 50mm</td> </tr> <tr> <td>Gloved hand:</td> <td>object plus 65mm</td> </tr> </table>		Bare hand:	object plus 50mm	Gloved hand:	object plus 65mm																																																																											
Bare hand:	object plus 50mm																																																																															
Gloved hand:	object plus 65mm																																																																															

Arm and hand access dimensions

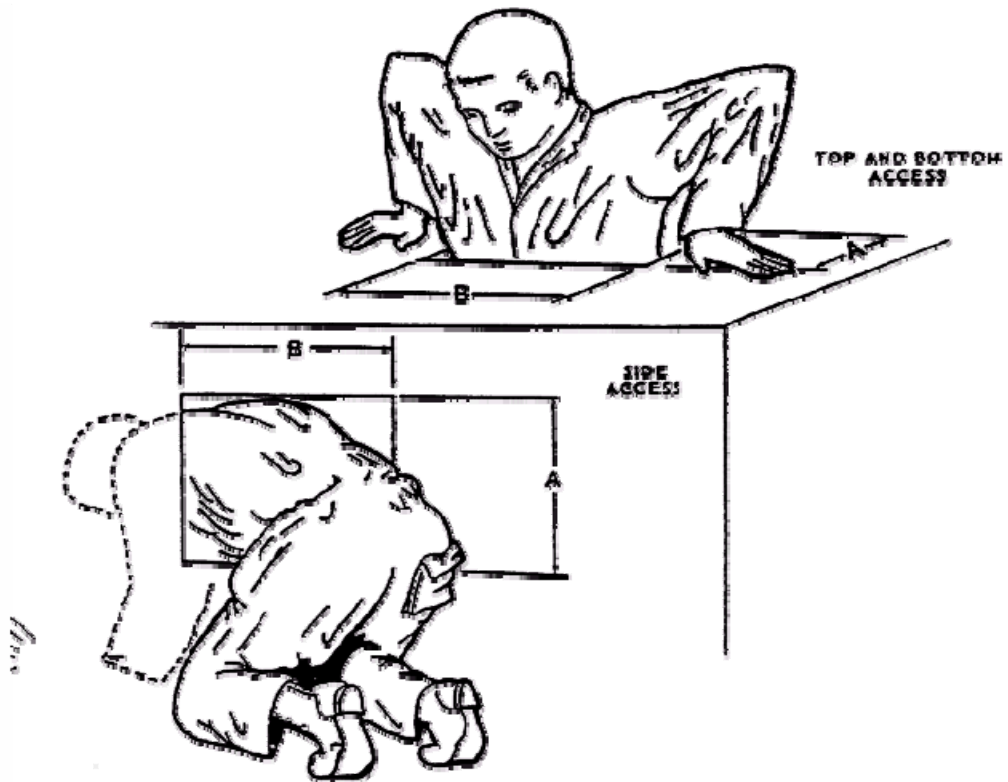

DIMENSIONS CLOTHING	A. DEPTH		B. WIDTH	
	LIGHT	BULKY	LIGHT	BULKY
TOP AND BOTTOM ACCESS	330 mm (13 in.)	410 mm (16 in.)	580 mm (23 in.)	690 mm (27 in.)
SIDE ACCESS	660 mm (26 in.)	740 mm (29 in.)	760 mm (30 in.)	860 mm (34 in.)

NOTE: DIMENSIONS SHOWN BASED ON MALE DATA.

Whole body access opening



Height to which lifted	Distance between body and grip			
	150 mm (6 in)	300 mm (12 in)	460 mm (18 in)	610 mm (24 in)
.9 m (3 ft)	20.2 kg (44 lb)	13.3 kg (29.3 lb)	10.1 kg (22 lb)	6.6 kg (14.7 lb)
1.5 m (5 ft)	16.8 kg (37 lb)	11.2 kg (24.7 lb)	8.4 kg (18.5 lb)	5.6 kg (12.3 lb)



Maximum weight of units to be lifted by one person (male or female)

HANDLING FUNCTION	POPULATION	
	Male and Female	Male Only
A. Lift an object from the floor and place it on a surface not greater than 152 cm (5 ft) above the floor.	16.8 kg (37 lb)	25.4 kg (56 lb)
B. Lift an object from the floor and place it on a surface not greater than 91 cm (3 ft) above the floor.	20.0 kg (44 lb)	39.5 kg (87 lb)
C. Carry an object 10 m (33 ft) or less.	19.0 kg (42 lb)	37.2 kg (82 lb)



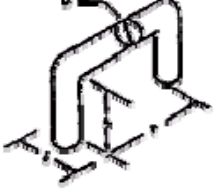
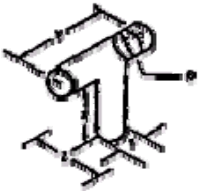

Maximum design weight limits

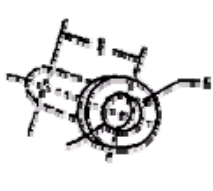
	Operability Hand-Held		Portability	
	Optimum	Maximum	One Person	Two Persons
Dimensions			Maximum	Maximum
Weight (kg)	1.4	2.3	11.3	40.8
Height (mm)	50	100	460	485
Length (mm)	200	255	460	
Width (mm)	100	125	255	

Weight and dimension limits of portable test equipment

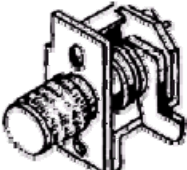
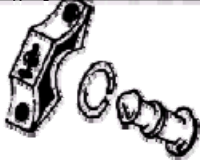
ILLUSTRATION	TYPE OF HANDLE	DIMENSIONS IN mm (in inches)								
		'Bare Hand)			(Gloved Hand)			(Mittened Hand)		
		X	Y	Z	X	Y	Z	X	Y	Z
	Two-finger bar	32 (1.27)	66 (2.6)	75 (3)	38 (1.5)	75 (3)	75 (3)	Not Applicable		
	One-hand bar	48 (1.875)	111 (4.375)	75 (3)	50 (2)	125 (5)	100 (4)	75 (3)	135 (5.25)	150 (6)
	Two-hand bar	48 (1.875)	215 (8.5)	75 (3)	50 (2)	270 (10.6)	100 (4)	75 (3)	280 (11)	150 (6)
	T-bar	38 (1.5)	100 (4)	75 (3)	50 (2)	115 (4.5)	100 (4)	Not Applicable		
	J-bar	50 (2)	100 (4)	75 (3)	50 (2)	115 (4.5)	100 (4)	75 (3)	125 (5)	150 (6)
	Two-finger recess	32 (1.25)	66 (2.6)	80 (3)	38 (1.5)	75 (3)	50 (2)	Not Applicable		
	One-hand recess	50 (2)	110 (4.25)	80 (3.1)	50 (2)	135 (5.25)	100 (4)	90 (3.5)	135 (5.25)	125 (5)
	Finger-tip recess	18 (0.75)	-	13 (0.5)	25 (1)	-	19 (0.75)	Not Applicable		
	One-finger recess	32 (1.25)	-	50 (2)	38 (1.5)	-	50 (2)	Not Applicable		
Curvature of Handle or Edge		Weight of Item			Minimum Diameter			Gripping efficiency is best if finger can curl around handle or edge to any angle of $\frac{2}{3}\pi$ rad (120°) or more.		
<b>(DOES NOT PRECLUDE USE OF OVAL HANDLES)</b>		Up to 6.8 kg (15 to 15 lbs)			D = 6 mm (0.25 in)					
		6.8 to 9.0 kg (15 to 20 lbs)			D = 13 mm (0.5 in)					
		9.0 to 18 kg (20 to 40 lbs)			D = 19 mm (0.75 in)					
		Over 18 kg (over 40 lbs)			D = 25 mm (1 in)					
		T-bar Post			T = 13mm (0.5 in)					

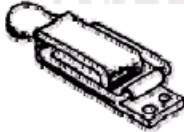
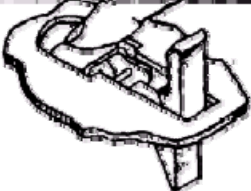
Minimum handle dimensions

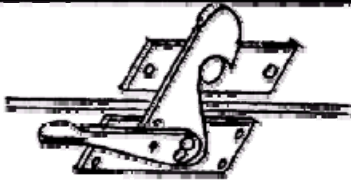
TYPE	DESCRIPTION
	<p>Adjustable pawl fastener.</p> <p>As knob is tightened, the pawl moves along its shaft to pull back against the frame. 90° rotation locks, unlocks fastener.</p>
	<p>"Dzus" type fastener with screwdriver slot.</p> <p>Three-piece 1/4-turn fastener. Spring protects against vibration. 90° rotation locks, unlocks fastener.</p>
	<p>Wing head. "Dzus" type.</p> <p>90° rotation locks, unlocks fastener.</p>
	<p>Captive fastener with knurled, slotted head.</p> <p>Retaining washer holds the threaded screw captive.</p>
	<p>Draw-hook latch.</p> <p>Two-piece, spring latch, base unit and striker. When engagement loop is hooked over striker, depressing lever closes unit against force of springs. Lever is raised to unhook.</p>
	<p>Trigger-action latch.</p> <p>One-piece, bolt latch. Depressing trigger releases bolt, which swings 90° under spring action and opens latch. To close, move bolt back into position.</p>
	<p>Snapslide latch.</p> <p>One-piece snapslide. Latch is opened by pulling lever back with finger to engage release lever.</p>
	<p>Hook latch.</p> <p>Hook engages knob on striker plate. Handle is pulled up locking in place. To release, reverse procedure.</p>

Fastener examples

Instructions	Number of Conductor	Basic Color	Tracer
1. Find the number of the conductor to be color coded.	1	Black	None
	2	White	None
	3	Red	None
	4	Green	None
2. The colors at the right of the number are the appropriate combination for that conductor. For example, if a cable consists of 12 conductors, the twelfth color combination would be black with white tracer. The eighth color combination would be red with black tracer. The fifth color combination would be orange without tracer, and so on.	5	Orange	None
	6	Blue	None
	7	White	Black
	8	Red	Black
	9	Green	Black
	10	Orange	Black
	11	Blue	Black
	12	Black	White
	13	Red	White
	14	Green	White
	15	Blue	White
	16	Black	Red
	17	White	Red
	18	Orange	Red
	19	Blue	Red
	20	Red	Green
	21	Orange	Green

NOTE: If a cable has concentrically laid conductors, the first combination or color applies to the center conductor. If a cable contains various sizes of conductors, the first color applies to the largest, continuing in order of conductor size.

## Electrical cable coding

Function	Color	Definition of Function
Intensified pressure	Black	Pressure in excess of supply pressure induced by a booster or intensifier.
Supply pressure	Red	Pressure of the power-actuating fluid.
Charging pressure	Intermittent Red	Pump-inlet pressure, higher than atmospheric pressure.
Reduced pressure	Intermittent Red	Auxiliary pressure lower than supply pressure.
Metered flow	Yellow	Fluid at a controlled flow rate (other than pump delivery).
Exhaust	Blue	Return of the power-actuating fluid to reservoir.
Intake	Green	Subatmospheric pressure, usually on the intake side of the pump.
Drain	Green	Return of leakage of control-actuating fluid to reservoir.
Inactive	Blank	Fluid within the circuit but not serving a functional purpose during the phase being represented.

## Hydraulic and pneumatic coding

Significant figures	Color	Multiplier	Color	Tolerance
0	Black	1	Black or no color	±20%
1	Brown	10		
2	Red	100	Silver	±10%
3	Orange	1,000	Gold	± 5%
4	Yellow	10,000		
5	Green	100,000		
6	Blue	1,000,000		
7	Violet	--		
8	Gray	--		
9	White	--		
--	Gold	0.1		
--	Silver	0.01		

Values for color-coded fixed resistors and small capacitors

Contents	Valve handwheels and operating levers	Fed. Std 595 color number and chip
Steam	White	17886
Potable water	Dark blue	15044
Nitrogen	Light gray	16376
High pressure air	Dark gray	16081
Low pressure air	Tan	10324
Oxygen	Light green	14449
Salt water	Dark green	14062
Fuel oil	Yellow	13538
Lube oil	Yellow	13538
Fire protection	Red	11105
Foam discharge	Striped red/ green	11105 14062
Gasoline	Yellow	13538
Feedwater	Light blue	15200
Hydraulic	Orange	12246
Freon	Dark purple	17100
Hydrogen	Chartreuse	23814
Sewage	Gold	17043

Color coding of fluid conductors

A - SUPERCILIARY ARCH REQUIREMENT	-----	17 mm (0.74")
B - NASAL BONE REQUIREMENT	-----	22 mm (0.875")
C - GREATER ALAR CARTILAGE REQUIREMENT	-----	32 mm (1.25")
D - SEPTAL CARTILAGE REQUIREMENT	-----	44 mm (1.75")

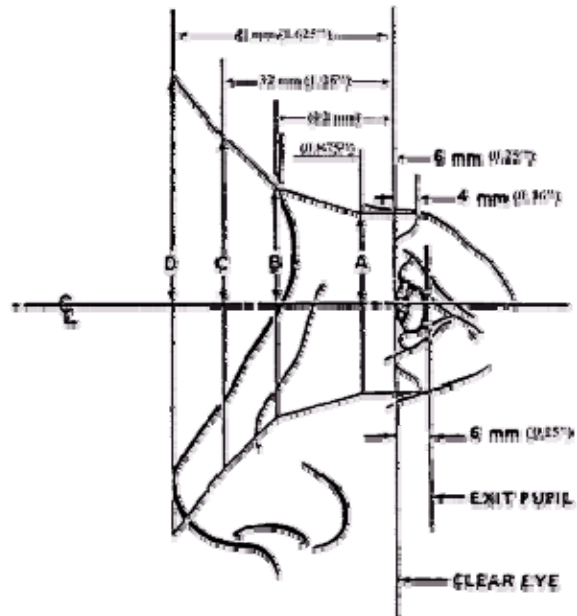
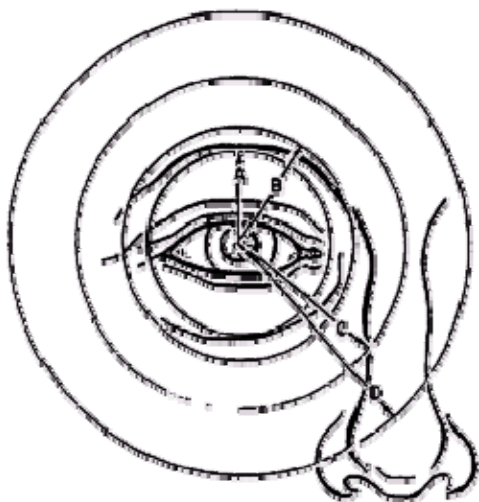

Anatomical limits on axially symmetrical ocular metal parts

A. Elbow (dynamic)	91 cm (36 in)
B. Elbow (static)	71 cm (28 in)
C. Shoulder	58 cm (23 in)
D. Knee width (minimum)	46 cm (18 in)
E. Knee width (optimum)	61 cm (24 in)
F. Boot (provide adequate clearance to operate brake pedal without inadvertent acceleration operation)	15 cm (6 in)
G. Pedals (minimum)	5 cm (2 in)
H. Boot (provide adequate clearance to operate accelerator without interference by brake pedal)	15 cm (6 in)
1. Head (seat reference point (SRP) to roof line)	107 cm (42 in)
2. Abdominal (seat back to steering wheel)	41 cm (16 in)
3. Front of knee (seat back to manual controls on dash)	74 cm (29 in)
4. Seat depth (seat reference point to front edge of seat pan)	41 cm (16 in)
5. Thigh (under side of steering wheel to seat pan)	24 cm (9.5 in)
6. Seat pan height	38 cm (15 in)
7. Boot (front of seat pan to heel point of accelerator)	36 cm (14 in)
8. Minimum mitten clearance around steering wheel	8 cm (3 in)
9. Knee–leg–thigh (brake/clutch pedals to lower edge of steering wheel)	66 cm (26 in)

### Recommended clearances around equipment operator's station



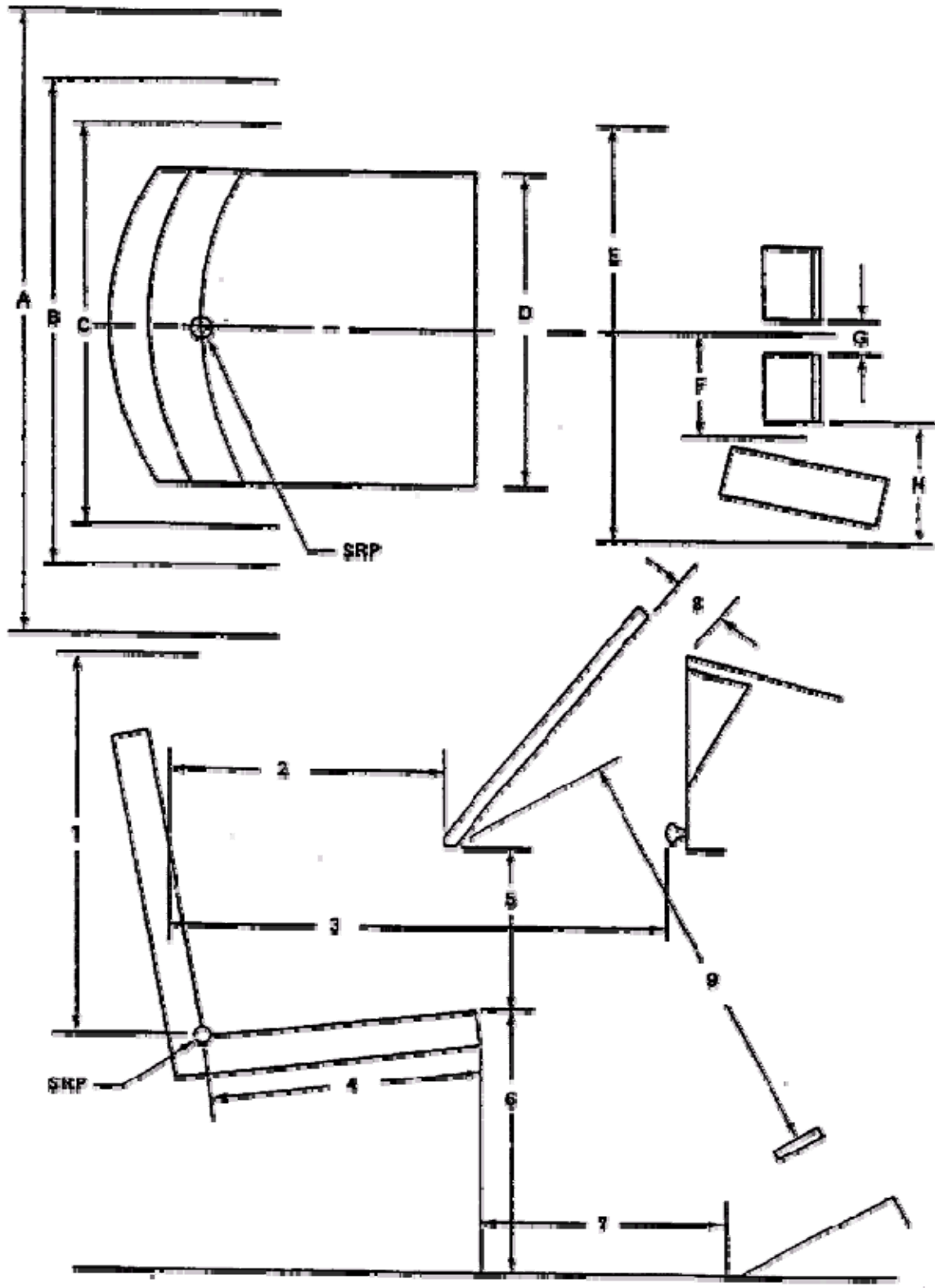

Recommended clearances around equipment operator's station key

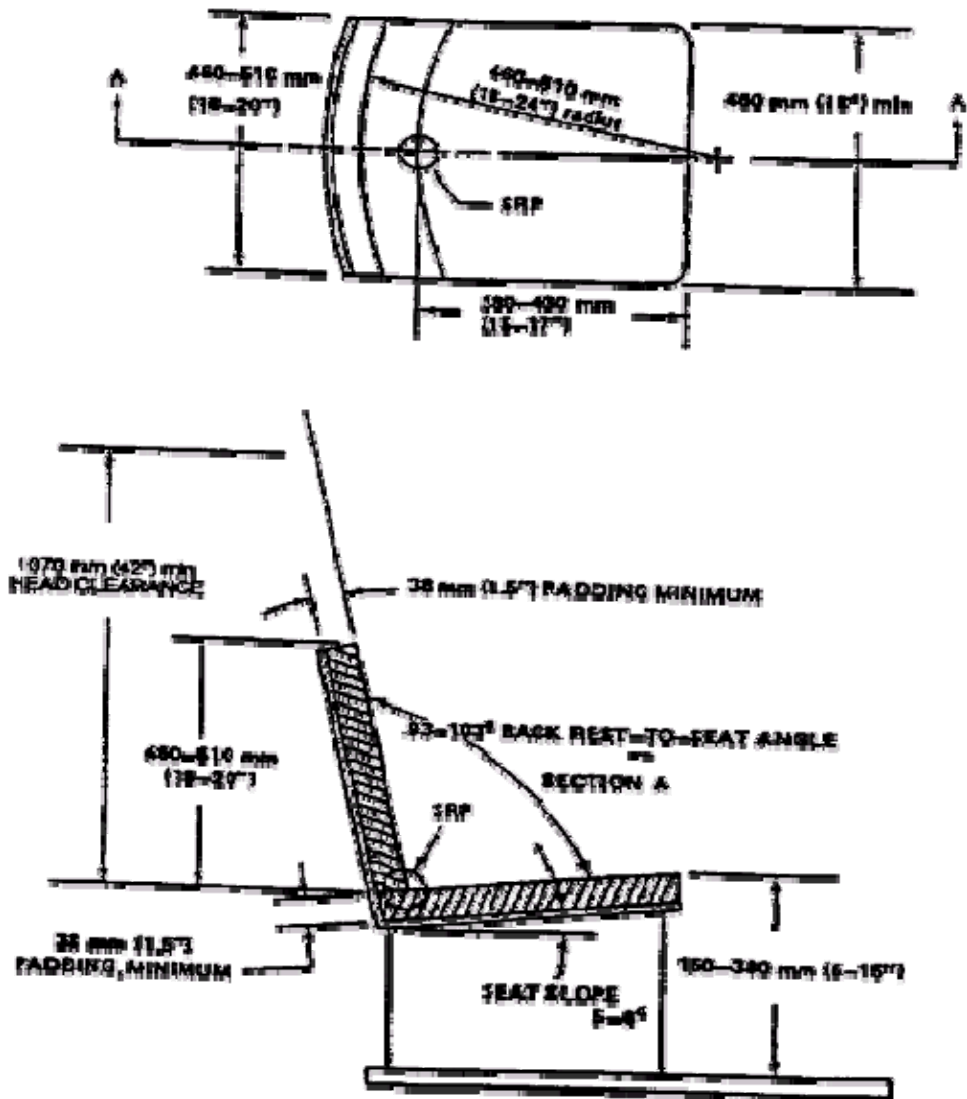

Dimensions for vehicle operator's seat

EXPOSURE	TEMPERATURE LIMITS		
	Metal	Glass	Plastic or wood
Momentary contact	60°C (140°F)	68°C (154°F)	85°C (185°F)
Prolonged contact or handling	49°C (120°F)	59°C (138°F)	69°C (156°F)

### Temperature exposure limits

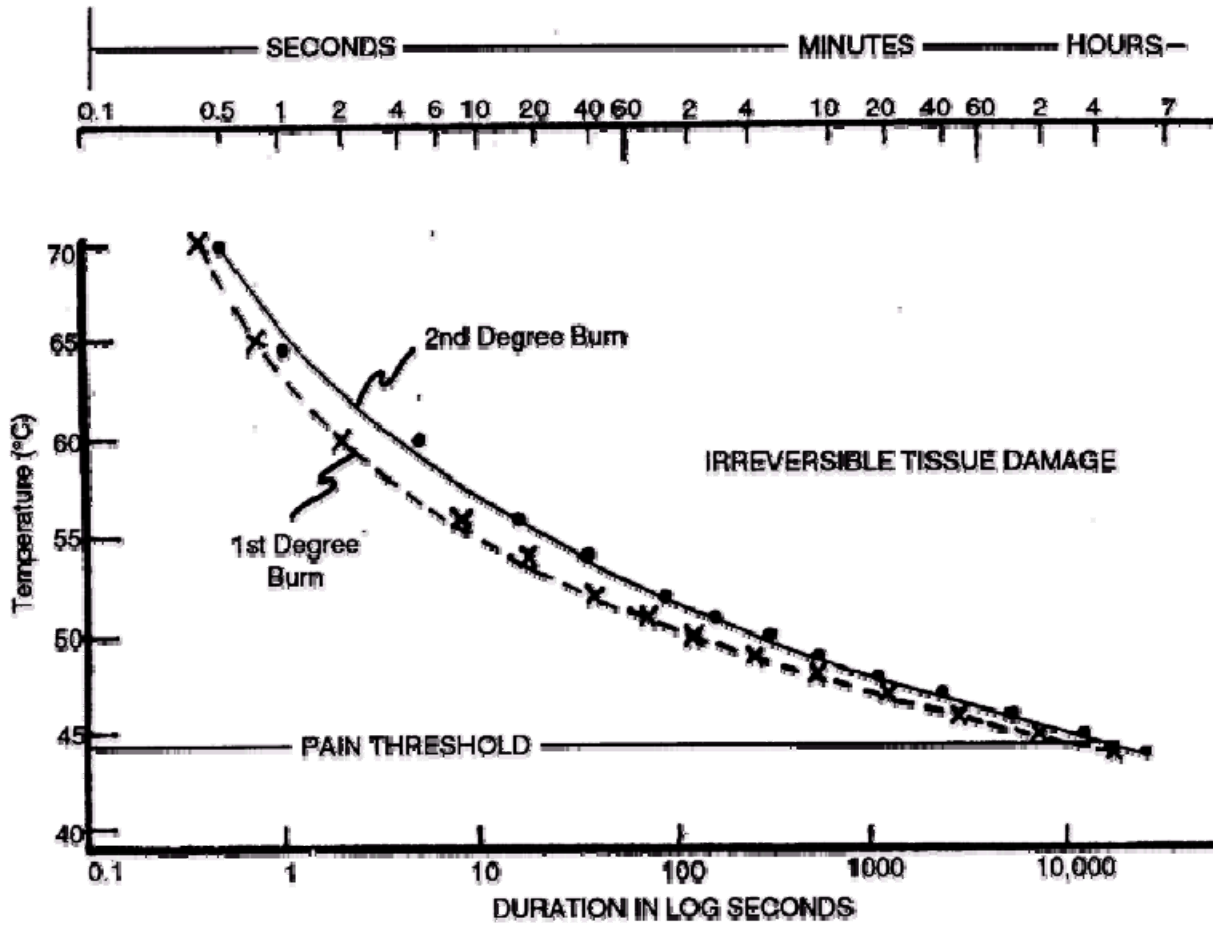

Burn criteria for human skin

$$E_{\text{eff}} = \sum E_{\lambda} S_{\lambda} \Delta_{\lambda}, \text{ where:}$$

$E_{\text{eff}}$  = Effective irradiance in the 200 nm to 315 nm

$E_{\lambda}$  = Measured spectral irradiance in  $\text{mW}/\text{cm}^2 \text{ nm}$

$S_{\lambda}$  = Relative spectral effectiveness (dimensionless) (see below)

$\Delta_{\lambda}$  = Bandwidth in nanometers (nm)

Wavelength (nm)	Relative spectral effectiveness ( $S_{\lambda}$ )	Daily exposure limit ( $\text{mJ}/\text{cm}^2$ )	Effective irradiance $E_{\text{eff}}$ ( $\text{mW}/\text{cm}^2$ )	Maximum exposure per day*
200	0.03	100	0.0001	8 hr
210	0.0075	40	0.0002	4 hr
220	0.12	25	0.0004	2 hr
230	0.19	16	0.0008	1 hr
240	0.3	10	0.0017	30 min
250	0.43	7	0.0033	15 min
254	0.5	6	0.005	10 min
260	0.65	4.6	0.01	5 min
270	1.0	3.0	0.05	1 min
280	0.88	3.4	0.10	30 sec
290	0.64	4.7	0.30	10 sec
300	0.30	10.0	3.00	1 sec
305	0.06	50.0	6.00	0.5 sec
310	0.015	200	30.00	0.1 sec
315	0.003	1000		

\* These values assume that no other occupational exposure occurs

## Exposure limit for ultraviolet radiant energy (200 – 315 nm)

Maximum hours per day	Sound level dBA (slow response) equivalent A-weighted sound level
--------------------------	--

8.0	90
6.0	92
4.0	95
3.0	97
2.0	100
1.5	102
1.0	105
0.5	110
0.25	115
Maximum impulse noise	140 (peak sound pressure level)

If daily exposure involves two or more periods at differing levels, the combined effect is used.  $C_j/T_j$  is the total time of exposure at a specified level over the time of permissible exposure for that typical level,  $j$ . When the sum,  $\sum(C_j/T_j)$  of the fractions,  $C_1/T_1 + C_2/T_2 + \dots + C_j/T_j + \dots + C_n/T_n$  is greater than one, the combined exposure exceeds the permissible noise limit value.

## Permissible noise exposure

CURRENT (milliamperes)		EFFECTS
AC (60 Hz)	DC	
0 - 1	0 - 4	Perception
1 - 4	4 - 15	Surprise
4 - 21	15 - 80	Reflex Action
21 - 40	80 - 160	Muscular Inhibition
41 - 100	160 - 300	Respiratory Block
Over 100	Over 300	Usually Fatal

Shock current intensities and their probable effects

<u>System Interpretation</u>	<u>Response Time Definition</u>	<u>Time (Secs)</u>
Key Response	Key depression until positive response, e.g., "click"	0.1
Key Print	Key depression until appearance of character	0.2
Page Turn	End of request until first few lines are visible	1.0
Page Scan	End of request until text begins to scroll	0.5
XY Entry	From selection of field until visual verification	0.2
Function	From selection of command until response	2.0
Pointing	From input of point to display point	0.2
Sketching	From input of point to display of line	0.2
Local Update	Change to image using local data base, e.g., new menu list from display buffer	0.5
Host Update	Change where data is at host in readily accessible form, e.g., a scale change of existing image	2.0
File Update	Image update requires an access to a host file	10.0
Inquiry (Simple)	From command until display of a commonly used message	2.0
Inquiry (Complex)	Response message requires seldom used calculations in graphic form	10.0
Error Feedback	From entry of input until error message appears	2.0

### Maximum acceptable system response times