

Unclassified Submission

Title of Data Item: Q1 2007 Progress Report

Data Item No.: A004

Contract Line Item No.: 0001

Contract: N00014-06-C-0068 (Metal Storm Active Protection System)

Submission Date: April 2007

SUMMARY OF WORK PERFORMED:

Program Activities:

TRC completed final integration testing with the FC440 and the XROWS. See exhibits 1 and 2. TRC traveled to the US Metal Storm office in March 2007 to demonstrate the completed user interface of the APS. The user interface shows the types of loaded ammunition, the number of rounds of each type remaining, and whether that ammunition type's launcher is armed. The user can select an ammunition type, and arm or disarm that ammunition type. "Arm all" / "Disarm all" buttons are also provided. Once an ammunition type is selected and armed, the user can fire a selected number of rounds of that ammunition at preselected targets.

(Exhibit 1)



(Exhibit 2)



Issue: Integration testing was performed in the Metal Storm facility on a static stand. All system components work, though some issues with cabling and the user interface of the software have been discovered. Also, the main system

Report Documentation Page

*Form Approved
OMB No. 0704-0188*

Public reporting burden for the collection of information is estimated to average 1 hour per response, including the time for reviewing instructions, searching existing data sources, gathering and maintaining the data needed, and completing and reviewing the collection of information. Send comments regarding this burden estimate or any other aspect of this collection of information, including suggestions for reducing this burden, to Washington Headquarters Services, Directorate for Information Operations and Reports, 1215 Jefferson Davis Highway, Suite 1204, Arlington VA 22202-4302. Respondents should be aware that notwithstanding any other provision of law, no person shall be subject to a penalty for failing to comply with a collection of information if it does not display a currently valid OMB control number.

1. REPORT DATE APR 2007	2. REPORT TYPE N/A	3. DATES COVERED -	
4. TITLE AND SUBTITLE Q1 2007 Progress Report		5a. CONTRACT NUMBER	
		5b. GRANT NUMBER	
		5c. PROGRAM ELEMENT NUMBER	
6. AUTHOR(S)		5d. PROJECT NUMBER	
		5e. TASK NUMBER	
		5f. WORK UNIT NUMBER	
7. PERFORMING ORGANIZATION NAME(S) AND ADDRESS(ES) Metal Storm, Inc. 4350 N. Fairfax Drive, Suite 810 Arlington, VA 22203		8. PERFORMING ORGANIZATION REPORT NUMBER	
9. SPONSORING/MONITORING AGENCY NAME(S) AND ADDRESS(ES)		10. SPONSOR/MONITOR'S ACRONYM(S)	
		11. SPONSOR/MONITOR'S REPORT NUMBER(S)	
12. DISTRIBUTION/AVAILABILITY STATEMENT Approved for public release, distribution unlimited			
13. SUPPLEMENTARY NOTES The original document contains color images.			
14. ABSTRACT			
15. SUBJECT TERMS			
16. SECURITY CLASSIFICATION OF:			17. LIMITATION OF ABSTRACT
a. REPORT unclassified	b. ABSTRACT unclassified	c. THIS PAGE unclassified	SAR
			18. NUMBER OF PAGES 5
			19a. NAME OF RESPONSIBLE PERSON

power is limited to using only 110VAC, when it was also supposed to be capable of using 28 VDC as is typical voltage on the UGV.

Fix: The cabling will be repaired and the software bugs will be documented for TRC. The power source may require separation from the system controller so that it accepts the proper input supply voltages from an AC/DC converter.

Continuation: Discuss the necessary changes with TRC and complete the integration effort.

Issue: The latest iteration of the Metal Storm MK16 munition displayed significantly improved ignition reliability; however, a weakness in the burner design was discovered to cause internal rupturing and premature fragmentation of the projectile body while still in the launcher assembly.

Diagnosis of the failures indicated that the press fit of the upper burner assembly was insufficient for the peak internal pressures.

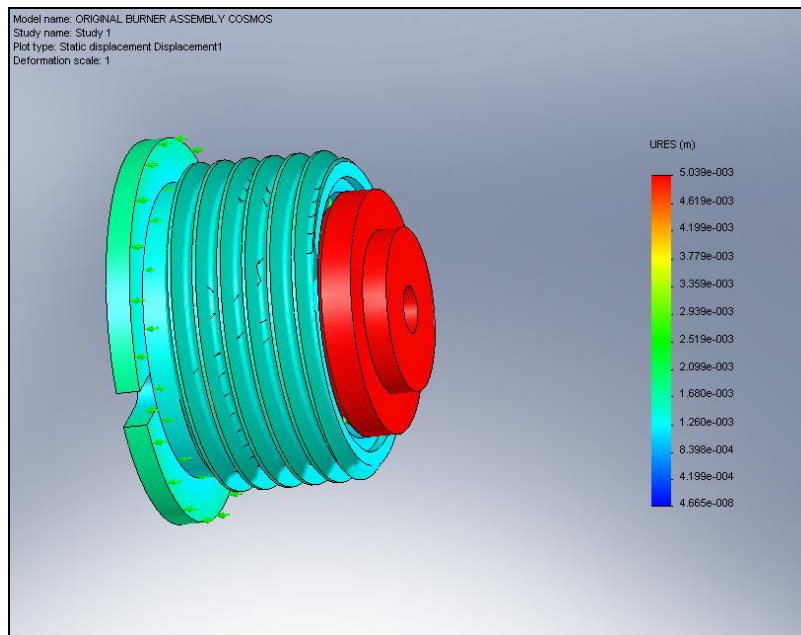

Displacement of Press-Fit Upper Burner Under Peak Pressure.

Fix: As a corrective action, Metal Storm initiated a quick react redesign to include a material change and a threaded interface of the burner components.

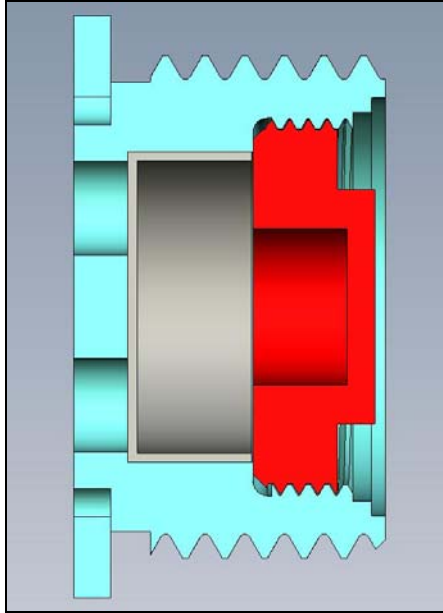

Threaded Mild Steel (vs Aluminum) Burner Assembly

Continuation: A statistically significant sample of the redesigned burner assemblies and their corresponding main level projectile assemblies will be tested this month to achieve confidence in munition reliability.

The adaptation of the M433 HEDP 40MM grenade to the Metal Storm launching technology has progressed to include an ogive design that has modeled to be suitable for testing. A bid to produce engineering models was initiated with American Ordnance. They were presented a SOW to support this development effort and have responded with an acceptable cost proposal. They were required to ask the US Army for a "use of facility" and which has been recently granted. The first ten engineering models will be completed by mid April and will be tested within a week upon arrival. Concurrently, the propulsion tail will evolve through a collaborative effort with the Brisbane office. The main focus of this effort is to confirm the modified ogive design so that it can withstand the forces unique to the Metal Storm weapon system with no or minimal negative effects on the performance of the fuze.

Static modeling of the modified ogive design shows that it should be more than capable of withstanding the stacking forces and pressures inside the launcher.

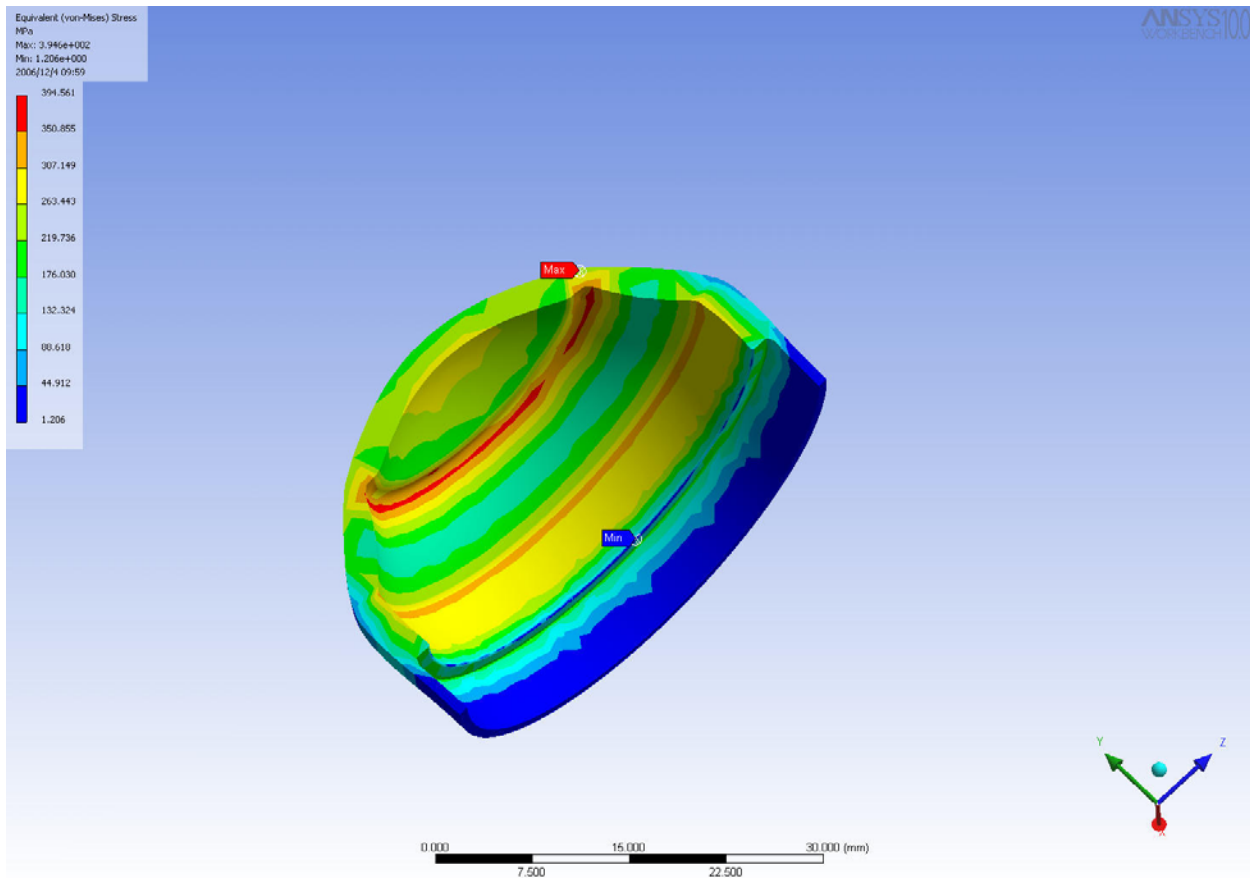

This was achieved by eliminating the actuator and integrating the functional features into the inside of the ogive such that it produced a thicker wall capable of surviving a launch of a preceding round. We do not have the capability to dynamically model the impact scenario, so that will be the focus of the post firing analysis. Each modified projectile manufactured by AO will be inert filled for accurate weight and CG for flight dynamics and the fuze will contain a witness, in place of the detonator, so that fuze functionality can be verified.

A suggestion to hold the anti-RPG capability demonstration in Singapore was presented to the ONR PM in the May/June 2007 timeframe. A detailed test plan and schedule are currently in development.

Metal Storm Products Scheduled For Use During The Phase 1 Trial:

- 96 MK16: TP (48), KE (48) projectiles
- 4 LVV4040: Metal Storm 40mm grenade launcher
- 1 FC440: Metal Storm 4 barrel fire control unit

- Custom cradle
- Custom T&E – TRC

PLANS FOR NEXT REPORTING PERIOD:

- Continue to solve the MK16 projectile issues so that the Phase I trial can be performed.
- Continue with the Phase 2 preliminary design through testing of engineering models.
- Resolve issues with the TRC system.
- Submit a test plan for the anti-RPG demonstration portion of this effort.