

**SAND2005-1701C**

**Unlimited Release**

**Printed February, 2002**

## **A Modified Perspective of Decision Support in C<sup>2</sup>**

Michael Senglaub, PhD,  
Dave Harris  
Sandia National Laboratories  
P.O. Box 5800  
Albuquerque, New Mexico 87185

### **Abstract**

Information processing and transformation in support of operations in combat environments have evolved well beyond the capabilities of classic deductive-inductive information systems. Unconventional warfare, and modern terrorism operate under conditions that do not lend themselves to pattern recognition techniques. The effort at Sandia National Laboratories is approaching the problem from an adaptive decision aid perspective in which new technologies are being hybridized to provide new and unique capabilities to deal with this new threat. These technologies are founded in Peircean reasoning and provide support for the various components needed to formulate a solution. The supporting technologies include formal concept analysis for knowledge representation, modal logic to provide guidelines for the movement and transformation of data and information, and a unique neural construct based on Hawkins concept of the neocortex. When integrated into a co-evolutionary game theoretic environment we believe we can provide capabilities of predicting the trends that will emerge in insurgency use of IEDs against combatants and non-combatants in theater.



*Sandia is a multiprogram laboratory operated by Sandia Corporation, a Lockheed Martin Company, for the United States Department of Energy's National Nuclear Security Administration under contract DE-AC04-94AL85000.*



# Report Documentation Page

Form Approved  
OMB No. 0704-0188

Public reporting burden for the collection of information is estimated to average 1 hour per response, including the time for reviewing instructions, searching existing data sources, gathering and maintaining the data needed, and completing and reviewing the collection of information. Send comments regarding this burden estimate or any other aspect of this collection of information, including suggestions for reducing this burden, to Washington Headquarters Services, Directorate for Information Operations and Reports, 1215 Jefferson Davis Highway, Suite 1204, Arlington VA 22202-4302. Respondents should be aware that notwithstanding any other provision of law, no person shall be subject to a penalty for failing to comply with a collection of information if it does not display a currently valid OMB control number.

1. REPORT DATE <b>FEB 2002</b>		2. REPORT TYPE		3. DATES COVERED <b>00-00-2002 to 00-00-2002</b>	
4. TITLE AND SUBTITLE <b>A Modified Perspective of Decision Support in C2</b>				5a. CONTRACT NUMBER	
				5b. GRANT NUMBER	
				5c. PROGRAM ELEMENT NUMBER	
6. AUTHOR(S)				5d. PROJECT NUMBER	
				5e. TASK NUMBER	
				5f. WORK UNIT NUMBER	
7. PERFORMING ORGANIZATION NAME(S) AND ADDRESS(ES) <b>Sandia National Laboratories, PO Box 5800, Albuquerque, NM, 87185</b>				8. PERFORMING ORGANIZATION REPORT NUMBER	
9. SPONSORING/MONITORING AGENCY NAME(S) AND ADDRESS(ES)				10. SPONSOR/MONITOR'S ACRONYM(S)	
				11. SPONSOR/MONITOR'S REPORT NUMBER(S)	
12. DISTRIBUTION/AVAILABILITY STATEMENT <b>Approved for public release; distribution unlimited</b>					
13. SUPPLEMENTARY NOTES <b>The original document contains color images.</b>					
14. ABSTRACT					
15. SUBJECT TERMS					
16. SECURITY CLASSIFICATION OF:			17. LIMITATION OF ABSTRACT	18. NUMBER OF PAGES <b>48</b>	19a. NAME OF RESPONSIBLE PERSON
a. REPORT <b>unclassified</b>	b. ABSTRACT <b>unclassified</b>	c. THIS PAGE <b>unclassified</b>			

## Contents

<b>A MODIFIED PERSPECTIVE OF DECISION SUPPORT IN C<sup>2</sup></b> .....	<b>1</b>
<b>ABSTRACT</b> .....	<b>1</b>
<b>CONTENTS</b> .....	<b>2</b>
<b>INTRODUCTION</b> .....	<b>3</b>
<b>PHILOSOPHICAL SOLUTION APPROACH</b> .....	<b>3</b>
<b>ARCHITECTURE</b> .....	<b>6</b>
<b>COMPONENTS</b> .....	<b>7</b>
REQUIREMENTS .....	8
TECHNOLOGIES .....	9
<i>Peircean Reasoning</i> .....	9
Reasoning Operators .....	9
<i>Knowledge Representation</i> .....	10
<i>Modal Logics</i> .....	12
<i>Neo-cortex Models</i> .....	12
<i>Co-evolutionary Models</i> .....	14
<b>CONCLUSION</b> .....	<b>14</b>
<b>REFERENCES</b> .....	<b>15</b>

## **Introduction**

The great military historians and scholars talk of the uncertainty associated with command in war, which we believe we are solving by the “information revolution”. A question we need to be asking ourselves, are we trading uncertainty due to an insufficiency of information with uncertainty due to a deluge of data. When we design elements of an information system we need to recognize the differences between reasoning and cognition, between data collection and fusion, between data presentation and situational awareness. Instead, we are integrating massive sensing capabilities into our combat systems, building huge data conduits and reservoirs into the infrastructures of our systems, and larding layers of complex, un-testable controllers and protocols onto the evolving architectures. What we are not doing is evolving the theoretical foundations needed to deal with these massive data collection capabilities. We see this failure in the design of fusion systems, in the inadequacies in the inherent security of the information systems and we see it in architectural constructs that run counter to the lessons of military history that van Creveld has shown lead to success.

In order to provide predictive decision aids we need to begin with an understanding of the processing and transformation of data and information as well as the flows of information. There also needs to be recognition or a perspective that information has value, and that information value is temporally and spatially dependent. Only then can we begin to understand the impact of information on the performance of decision aids within systems that support command and control. If we take a step back to explore the essence of command and control, we begin to recognize that decisions are based on a “belief state” of a decision maker or of a cognitive collective. With these fundamental perspectives we can begin to integrate research and ideas from the fields of logic, philosophy of science, and information science to identify potential solutions. Interestingly, we need to consider augmenting systems engineering principles to employ pragmatism as a validation mechanism for problems in these domains. To deal with these new problems we need to explore a number of new and potentially unorthodox avenues of research.

At Sandia National Labs we have begun a research effort that is beginning to examine the implications of these technologies in providing new capabilities in the areas of decision support. The focus of these initial efforts is the co-evolutionary problem of improvised explosive devices (IEDs). The co-evolutionary aspect of the problem is based on evidence associated with the IRA bombing campaign in Northern Ireland. In the sections to follow we begin to explore technologies and provide some justifications for pursuing them in support of adaptive decision support systems. We will take brief looks at models of command and control, provide arguments for including modal logics in the design solutions, identify systems of reasoning and explore knowledge representation systems. With these stretch technologies we will also provide some discussion of the architectures needed to address the co-evolutionary and operational aspects of the problem.

## **Philosophical Solution Approach**

The design and development of decision aids, which could be integrated into the military decision making process (MDMP), provides an opportunity to take a step back and examine the problem from a fundamental perspective. This permitted us to examine in

greater detail the requirements and the potential technologies that could be accessed in an endeavor to find viable solutions. The decision aid problem can be naturally split into understanding the decision making process, understanding information and the various transformation performed on information, understanding reasoning and logic, and recognizing the constraints associated with operational issues. Within these areas are a number of sub-categories that must also be considered.

The first area of consideration involves the decision making process and how we reason in that process. Research has shown that decisions are based on a belief state. As we gather data and information with respect to some situation we correlate that data with knowledge we possess. The knowledge represents capabilities in tactics for example, or in our ability to generate, detect or mitigate a threat. In a combat environment decisions have to be made quickly and under varying degrees of uncertainty. The belief state constitutes a decision makers best estimate of the tactical situation. Given that estimate or belief state, actions are identified that will lead to mission success, or mitigate a threat. Decision making can be represented by the next figure.

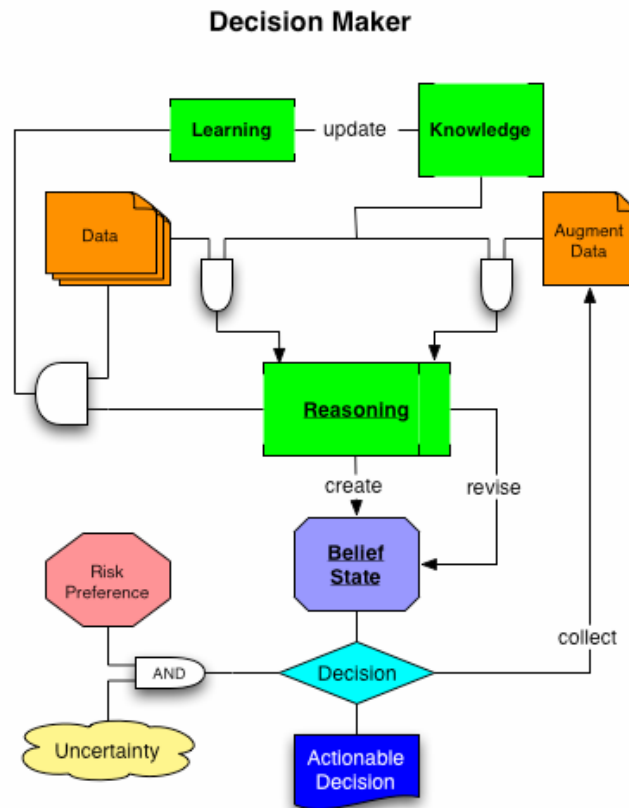

Figure 1. Model of decision making by a commander or cognitive collective.

Decision making is a complex process in which learning becomes an element that forms the basis for updating knowledge. Similarly we see mechanisms in which the decision makers “belief” state is revised with the introduction of new information. Within this complex process we see that the belief state can be conditioned by such intangibles as risk aversion. What has not been included in this figure are many of the social

psychological factors that also affect the belief state. The model does provide a framework for developing and optimizing decision aids to maximize their effectiveness.

The next major consideration in the design of decision aids concerns the reasoning engines used through out the implementation. We have focused on a Peircean construct after a number of years of exploration into the problem of reasoning under uncertainty and dealing with problems that require hypothesis generation. The construct is based on the work of the philosopher C.S. Peirce. His work recognized and articulated the human reasoning process as being comprised of three components; abduction, deduction, and induction. This foundation was characterized as the method of scientific inquiry. His work goes far beyond the mere characterization of reasoning to include insights into the communication of ideas and the logic that enables that communication. Any attempt to develop systems that endeavor to solve previously unseen problems must consider abduction as integral to the solution strategy.

The next figure captures the three components of human reasoning as defined by Peirce. Each box attempts to show the characteristic of the component.

### Components of Peircean Reasoning

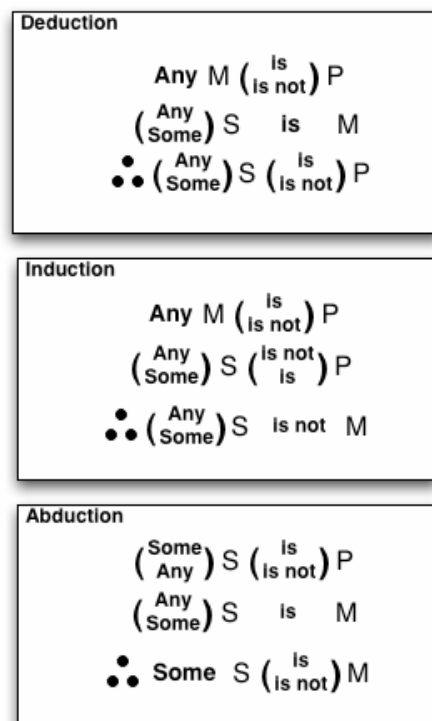

Figure 2. Foundation elements of Peircean reasoning.

Interestingly Induction serves two major roles in human reasoning, it provides the basis for validating hypotheses generated in the abduction process and it provides a basis for learning. The best treatise on induction is D. Mayo's work on statistics and her concept of severe testing.

A third area of concern involves knowledge representation (KR). Issues associated with KR include; the capture, organization, and retrieval of large amounts of domain knowledge for use in an abductive process. Davis identifies five roles crucial to knowledge representation systems. These five roles consist of: it being a surrogate for an object, an ontological commitment, a partial theory of reasoning, a medium for efficient computation, and it is a medium for human expression. Interestingly there is a great deal of overlap in Davis's roles for a KR system and Peirce's concepts of reasoning and his theory of "sign". A technological approach for dealing with KR has been satisfied by exploring formal concept analysis.

The last major piece(s) deal with the problem domain. In this case we are exploring the design issues associated with a problem domain considered co-evolutionary, i.e. the improvised explosive device (IED) problem and an operational environment that is not conducive to real time analyses. The evolutionary nature of the problem is being addressed through an evolutionary game theoretic methodology. The real time issues are being dealt with by splitting the problem into a background, probably offline analysis, that supports a real time fusion augmentation application that is integrated into a MDMP capability.

### **Architecture**

As indicated in the last section the solution approach being proposed consists of two major pieces. The first piece is a game theoretic system that uses elements of the command decision-making paradigm to postulate threats and solutions based on tactical and IED domain specific knowledge. That knowledge is augmented with knowledge domains identified by the inherent abductive algorithms and an intelligence estimator. The basic structure of the evolutionary game theoretic is symmetric and employs Peircean derived reasoning engines in both components of the system. This permits all players in the selected domain to adapt to changing situations and ideally adjust to local conditions as these factor impact the competitive environments.

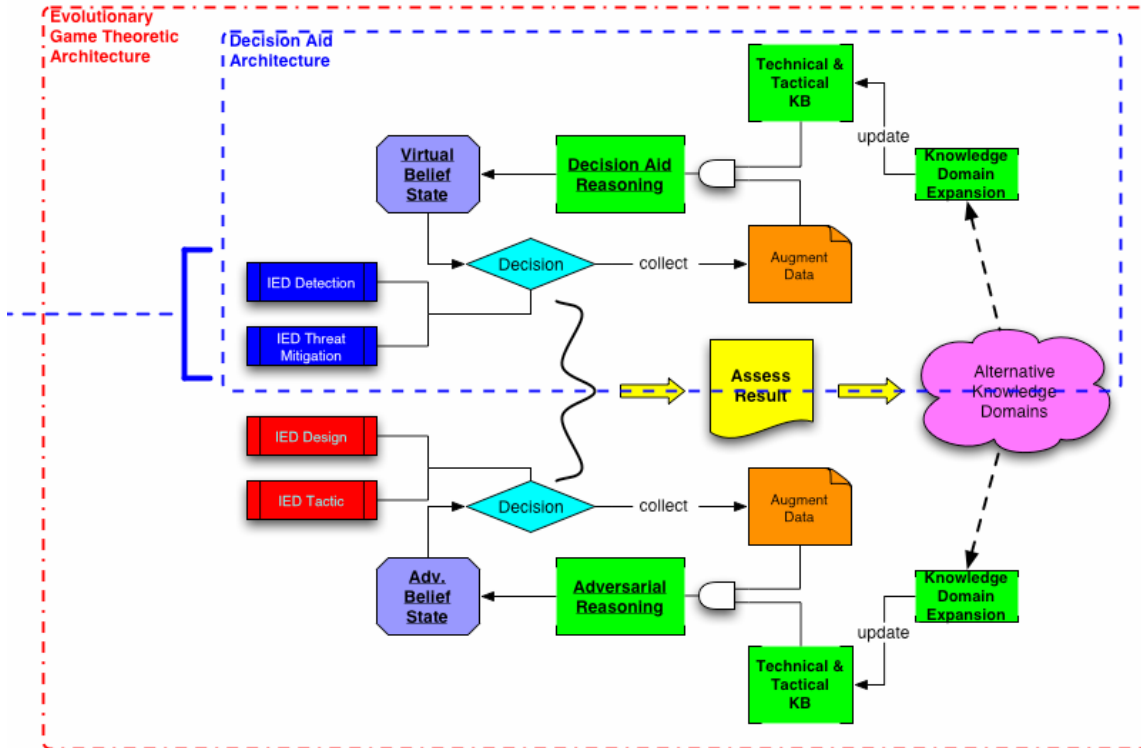

Figure 3. Co-evolutionary architecture used in the adaptive decision aid.

The reasoning engines provide the basis for the virtual belief systems of the competing entities. This can be seen in the architectural figure above. What is different from the command and control model is the fact that in the virtual environment we are not integrating risk aversion into the adversarial players. For the application domain under consideration risk aversion will not significantly impact the results of the models.

The second piece of the adaptive decision aid architecture is a light weight component that can be integrated into either the military decision making systems or can be developed as a support function for use by task commanders. The current proposed approach is to use a partially observed Markov decision process (POMDP) to provide process alternatives based on current and desired states for the command task leader. This lightweight component could be implemented in PDA or something as simple as a “post-it” note approach. The computation power required by the co-evolutionary algorithms do not lend themselves to real time solutions, so would run independently.

### Components

As indicated by the architectural section, a number of basic components need to be assembled in a hybrid structure in order to realize a system solution. In today’s environment we are generating a true system of systems solution because we will rely on an information coupling of a number of the component or sub-systems of the decision aid solution. The major components of this system solution consist of the reasoning engines which are based on Peirce’s philosophy of science and the reasoning system he proposed. This system consists of an abductive, deductive and inductive structure in which we propose using abductive algorithms based on John Stewart Mills’ canons. The inductive



component must provide a capability that reflects Debra Mayo's concepts of statistical induction and in particular her idea of severe testing. These subcomponents comprise the core elements of the reasoning engine.

The second major component of this system consists of the knowledge representation system. Knowledge provides the reference by which data is assessed and belief states generated. Belief provides the basis on which the ultimate decisions rest. The work being conducted in Germany and in Australia in the fields of formal concept analysis provide the most robust and flexible system of knowledge representation in the literature. This system also is founded on a significant body of mathematical knowledge, lattice theory. This mathematical foundation provides proven methodologies for the manipulation and transformation of the knowledge that these structures capture.

The third major component of the system requires the integration of the sensor / intelligence component of the system. What has been discovered by this team is a model of the neo-cortex which supports efforts in psychologically based cognition, and more importantly, supports the extensive work identified by Peircean reasoning. This work identifies the natural feed-back mechanisms articulated by Peirce in his philosophically based reasoning descriptions and provides for the potential use of modern neural networks combined with lattice structures to enable the movement of information from a sensing space to a knowledge space.

A final component concerns the linkage of the major components of the system. Information provides the basis for linking the data collection, knowledge storage and retrieval and the belief system. The transformation and flow of information must be governed by the rules of modal logics. The fact that information possesses a temporal as well as spatial value seems to elude the majority of researchers in the information communities. Research in the domain of modal logic aids in the design of and the measurement of information flow and transformation (fusion) systems.

### **Requirements**

At a qualitative level, requirements are most severe on the knowledge representation system. This system must be flexible, since new knowledge will be continually added to the system as well as fast. In this case the storage and recovery of knowledge will occur many times during the course of an evolutionary cycle. The lattices will be searched many times as methods of IED assembly are explored and counter measures are assessed in a tactical environment. Additionally, the environment should support an explanation function, which many decision aid designs seem to forgo. Providing a tactical commander with information concerning the solutions being suggested gives him/her the ability to augment the proposed solutions with local real time information in a much more effective manner.

The second area of qualitative requirements assessment resides in the reasoning engine domains. The solutions being proposed have already incorporated many of these qualitative requirements, which consist of a reasoning engine that generates hypotheses. The domains being addressed by this research do not lend themselves to "pattern matching" solution technologies. Approaches based on pattern matching require prior examples with an extensive signature database to generate high reliability solutions. The realm of insurgency activity, terrorism, and in general unconventional warfare are forms

of conduct in which new problems are the rule of warfare rather than the exception. The solutions must be able to adapt to or better anticipate the actions of this type of adversary. A second major qualitative requirement of this reasoning engine revolves around the inductive component. In this case evidence must provide discrimination of hypotheses. Mayo's concept of severe testing provides the basis for discrimination. The difficulty being faced in this tactical domain concerns the fact that Peirce as well as Mayo are statistical frequentist' while the domain is a very Bayesian domain. Some follow-on research needs to be conducted that explores / assesses the impact on the theoretical foundations of this Bayesian bias.

**Technologies**

The sections that follow provide information related too the components of the adaptive decision aid being developed in this research effort. It is hoped that there is sufficient information to entice the reader to explore the subject mater in further detail rather than supply a definitive answer. There is insufficient space to provide that degree of detail.

**Peircean Reasoning**

The core component or principle of this effort revolves around the system of reasoning defined by C.S. Peirce. This work, which was completed around the turn of 1900, provides a basis for information operations and the various transformations on information. The key defining rational for use in an adaptive information applications is the concept of abduction in Peirce's system of reasoning. This concept, which was also referred to as retrodution by Peirce, when combined with induction provides a mechanism for hypothesis generation. It is this function that is required by a reasoning system to begin to tackle the daunting task of predicting / anticipating future actions.

In Peirce's philosophy of science, he identified a model of reasoning which is the core process of human cognition. What Peirce did not address in his work were the elements of psychology that color and make unique the decisions we make and the conclusion that we draw as individuals. Peirce's contributions to the fields of philosophy of science, ethics, and logic are substantial. The fragment we are employing concerns the reasoning system, consisting of the three components identified in the next figure.

**Peircean System of Reasoning**

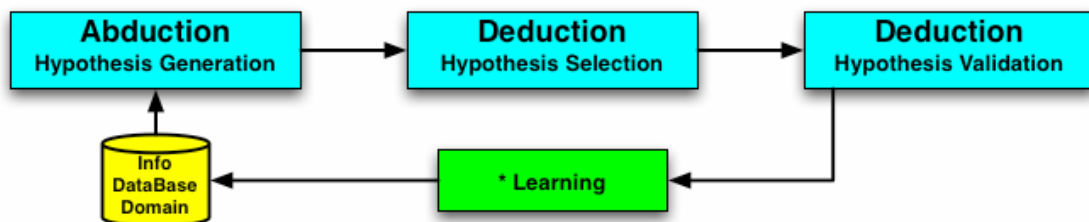

Figure 4. Peircean system of reasoning with \* Nozawa's learning observation.

Reasoning Operators

The operators being defined or designed for this reasoning construct are based on the five canons of John Stuart Mill. Initial work by Burch and Finn have focused on the first canon and involved significant effort at validating these canons in a much larger philosophical and logic context. In this effort we are taking a more Peircean, pragmatic approach to selecting and implementing the operators. The five canons consist of those identified in the next figure.

- **Method of Agreement**
- **Method of Differences**
- **Indirect Method**
- **Method of Residues**
- **Method of Concomitant Variations**

Figure 5. J.S. Mill's canons.

The first canon: *If two or more instances of the phenomenon under investigation have only one circumstance in common, the circumstance in which alone all the instances agree, is the cause (or effect) of the given phenomenon.*

The second canon: *If an instance in which the phenomenon under investigation occurs, and an instance in which it does not occur, have every circumstance save one in common, that one occurring only in the former; the circumstance in which alone the two instances differ, is the effect, or cause, or a necessary part of the cause, of the phenomenon.*

The third canon: *If two or more instances in which the phenomenon occurs have only one circumstance in common, while two or more instances in which it does not occur have nothing in common save the absence of the circumstance; the circumstance in which alone the two sets of instances differ, is the effect, or cause, or a necessary part of the cause, of the phenomenon.*

The fourth canon: *Subduct from any phenomenon such part as is known by previous inductions to be the effect of certain antecedents, and the residue of the phenomenon is the effect of the remaining antecedents."*

The fifth canon: *Whatever phenomenon varies in any manner whenever another phenomenon varies in some particular manner, is either a cause or an effect of that phenomenon, or is connected with it through some fact of causation.*

The descriptions of the canons come directly from Mill's *System of Logic*, and will form the basis for the knowledge operators in the system.

### Knowledge Representation

The effort has focused on the use of formal concept analysis as knowledge representation mechanism. The technology has an extensive following in Germany and Australia and is founded on lattice theory. This provides a powerful mechanism for manipulation of knowledge in a manner consistent with epistemic theories of logic. Formal concept analysis provides a user with multiple domains of representation as indicated in the next figure.

Animals	Preying	Flying	Bird	Mammal
Lion	x			x
Finch		x	x	
Eagle		x	x	
Hare				x
Ostrich			x	

Figure 6. Formal concept representation alternatives.

Figure 6. Formal concept representation alternatives.

Some of the properties that make the technology desirable include the expandability of a context, “Animals” in the figure. The mathematical foundations of lattice theory provide powerful theorems for various operations on the lattices. Ganter & Wille formally define concept lattices to be complete, closed and possess a sub / super concept structure. As a result, the decomposability and extensibility are key features needed in this problem domain.

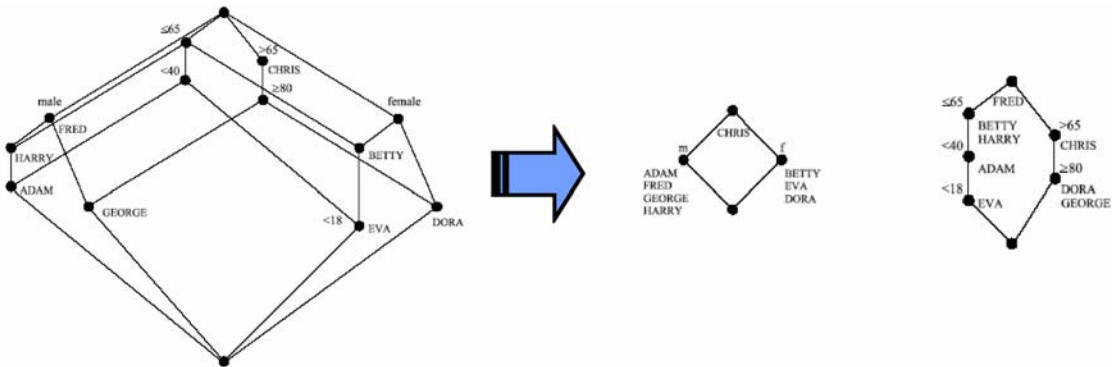

Figure 7. Decomposability of a formal concept lattice.

If you consider a dimensionality with either the matrix or the lattice you could consider alternative dimensions representing different functionality. In this case the concepts could be parsed in such a manner that the construction of IEDs is one dimension while detection and mitigation would be two additional dimensions.

There is a significant research effort in the area of formal concept analysis and lattice theory. One area of effort involves enhancing the utility and readability of the concept

lattice. Efforts by Pogel at NM State provides methodologies for the visualization based on notions of semantics. A significant amount of research may be leveraged to tackle the representation problems of this effort.

### Modal Logics

As a result of efforts in support of vulnerability assessments in the information domain, a serious gap seems to exist between the perception of what needs protecting and the theoretical roots for building systems that support information operations. These roots lie in the obscure fields of modal logics. I say obscure only because conversations concerning the research topic can quickly give an old systems engineer a serious headache. What we find is extensive work in these areas that provides a basis for the various transformations that must be performed on information in modern combat systems. When we examine information in greater detail we begin to recognize the temporal and special value associated with information. Neglecting these considerations in the design of systems that operate on information produces solutions that have a patchwork quality, that are cumbersome, and have security holes large enough to drive an M1 through.

Study of epistemic logic begins to improve the situation by providing a foundation for the operational transformations of knowledge. Belief being based on a convolution of knowledge and data from the battle space requires a theoretical foundation for knowledge acquisition, knowledge retrieval, and the knowledge update process by providing control and validation to the knowledge underpinnings of the system.

Doxastic logic provides the theoretical foundation for the belief system and the belief revision that forms the decision support structure. Since command decisions are based on belief, we must understand the theoretical structure for this part of the system. Doxastic logic provides a structure and adds rigor to a belief revision system that aids in ensuring new information remains consistent with what has already been established.

Information possesses a definite temporal dimension, which enters this problem domain through the intelligence function and the desire to identify avenues of development. Again, this modal logic aids in the processing of information whose relevancy is of limited duration. Temporal logic must augment the doxastic and epistemic systems since belief and knowledge is required to evolve over time. The knowledge foundations, which are conditioned using epistemic logic, are being forced to evolve by the co-evolutionary nature of the game theoretic.

While real world information systems must deal with emotions or personalities and certain ROE's the initial systems will not address deontic logic issues.

### Neo-cortex Models

Hawkins regarding the structure and the function of the human brain has proposed a number of novel, and innovative ideas. He concludes that the primary functions of the neocortex are independent of the high level functions associated with a sensory region. He has also recognized a representational invariance of knowledge stored within the neocortex. These two facts provide goals for the algorithms to be used in the knowledge representation system.

Of significant interest is the description of the six layers of the neocortex and the “wiring” between the layers. There is a classic neural, feed-forward architecture, which is temporally based, and a feedback mechanism. The feedback mechanism seems to connect each abstraction layer to all layers of lesser abstraction. This feedback loop provides the basis for a predictive type function. The predictions serve to inform an input layer what might be expected given preliminary sensory input. It seems to the authors that this might constitute a physical manifestation of Peirce’s abduction function.

The description of the neocortical structure and function provides an interesting opportunity to hybridize modern neural nets (NN) with lattice structures to provide a very efficient data to concept knowledge representation and transformation model. The various levels of abstraction could be viewed as the output of one NN providing the input to the next level NN abstraction. A crude view of this hybridization is provided in the next figure. What is not shown are the additional “cross linkages” between the various high level functional regions of the neocortex. Capturing these linkages in computer simulation may provide insights into multi-spectral data fusion.

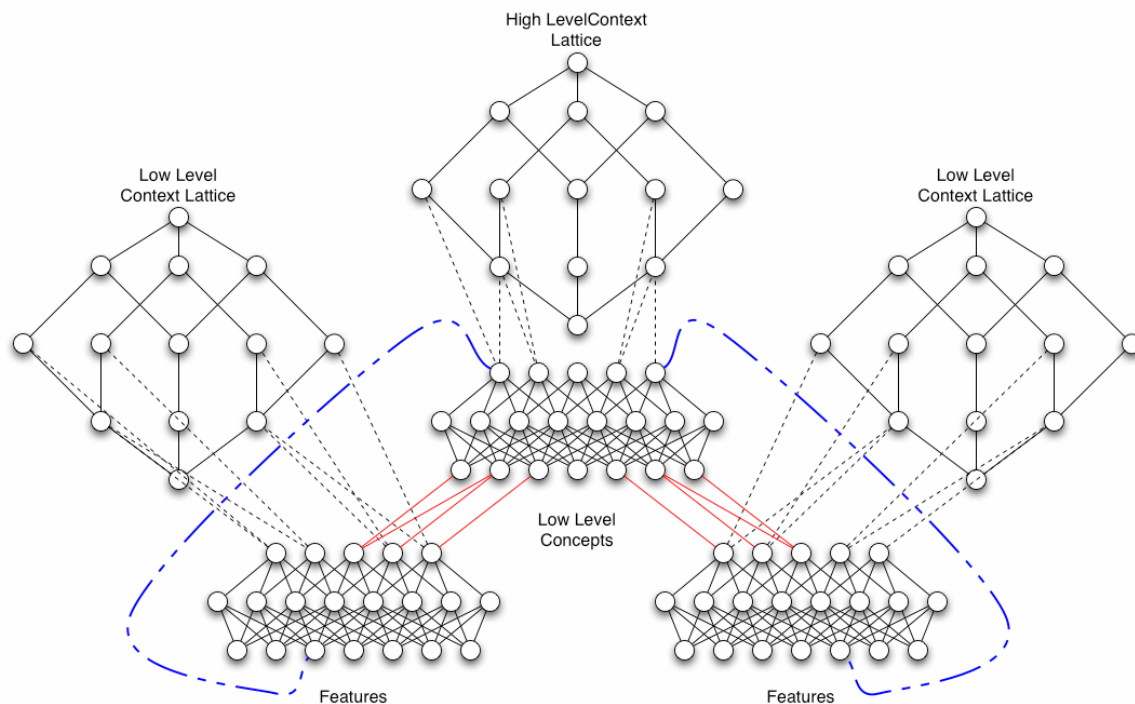

Figure 8. Hybrid neural net and lattice model of knowledge representation and transformation.

The linked lattice structures provide a mechanism for machine understanding and manipulation of knowledge, potentially acting as probes.

One aspect of Hawkins revelations involves the temporal nature of the neocortical functions. He identifies a spacial and temporal dimension to sensory input such as touch requiring moving the hand to get the feel of surface roughness, or the eye saccade as part of the mechanism of capturing visual information. It needs to be explored how these hybrid structures can be made to reflect the spacial and temporal qualities needed in this effort.

## Co-evolutionary Models

The co-evolutionary aspect of the problem has its roots in game theory in which a non-cooperative game is played using pure and mixed strategies. Under these conditions the game is played one time with a payoff matrix defining the results of the game based on the strategies. In pure game theory Nash equilibrium is the condition that results from a mixed strategy and constitutes the best possible result of the game in which the players are rational players.

Evolutionary game theory modifies the game by playing repeated games, again in a non-cooperative environment. In this approach, each time the game is played the game participants are drawn from a population of players each having the same or different strategies of play. Under the rules of this game a process is defined for modifying the population of players. The operators defining the modification can be designed based on the objectives of the game. The other significant difference of this game theoretic approach involves the fact that there is no guarantee that the solution will evolve to a Nash equilibrium. In the case of evolutionary game theory the solutions evolve to the evolutionary stable strategy or ESS.

Finally, in a co-evolutionary game theoretic environment we are removing all restrictions on the nature of the game. In this case it could be thought of as a game in which the rules are changing as well as the playing pieces. The strategies, rather than being defined by a population of potential players, are being defined by reasoning entities integral to the game. The implications of this approach are not yet clear, but we expect to see behavior similar to the evolutionary game theoretic in which we evolve to an ESS. This ESS then provides the basis for defining and constructing the lightweight decision aid to become part of the MDMP process.

## Conclusion

Extensive work and experience is being brought to bear to tackle the difficult problem of IED detection in a highly adaptive environment. Technologies have been identified that support the qualitative requirements of an adaptive decision system. While a number of the technologies have been validated in isolated applications, the highly hybridized solution proposed has not yet been validated. Part of the objectives of this effort are also to bring an awareness of innovative technologies and the much needed theoretical roots of an information based approach to finding robust solutions to decision support. The ultimate objective is to provide a war-fighter with tools that reduce his/her workload while enhancing their situational awareness. Solutions that add to the workload of a soldier under fire display a lack of operational consideration and should be field-tested by the designer.

## References

1. R. Davis, H. Shrobe, & P. Szolovits, "What is a Knowledge Representation?", AAAI Publication, Menlo Park, Ca; Spring 1993, 0738-4602-1993, pp17-33.
2. Ganter, B. & Wille, R., "*Applied Lattice Theory: formal Concept Analysis*", exact citation UNK. ( [www.mathematik.th-darmstadt.de](http://www.mathematik.th-darmstadt.de) )
3. Hawkins, Jeff, "On Intelligence", Times Books, N.Y., 2004, ISBN 0-8050-7456-2.
4. K. Ketner, editor "Reasoning and the Logic of Things", Harvard University Press, Cambridge, 1992, ISBN 0-674-74967-7.
5. D. Mayo, "Error and the Growth of Experimental Knowledge", University of Chicago Press, Chicago, 1996, ISBN 0-226-51198-7.
6. Mill, J.S., "System of Logic, Ratiocinative and Inductive", Harper-Brothers, N.Y., 1850.
7. E.T. Nozawa, *Peircean Semeiotic A New Engineering Paradigm for Automatic and Adaptive Intelligent Systems Design*, LM Aero, Marietta Ga. 30063. [www.d.kth.se/~tessy/Nozawa.pdf](http://www.d.kth.se/~tessy/Nozawa.pdf)
8. Pogel, A., Hannan, T., Miller, L., "Visualization of Concept Lattices Using Weight Functions", Physical Science laboratory, NM State University., ([Alex.Pogel@psl.nmsu.edu](mailto:Alex.Pogel@psl.nmsu.edu))
9. P. Turrisi, editor, "Pragmatism as a Principle and Method of Right Thinking", State University of New York Press, Albany, 1997, ISBN 0-7914-3266-1.
10. van Creveld, M.; "*Command in War*"; Harvard University Press, Cambridge Mass., 1985, ISBN 0-674-14441-
11. Weibull, J., "Evolutionary Game Theory", MIT Press, Cambridge, 1996, ISBN 0-262-23181-6.





SAND2005-2938C

# **A Modified Perspective of Decision Support in C<sup>2</sup>**

**June 14, 2005**

**Michael Senglaub, PhD  
Dave Harris  
Sandia National Labs**



# Briefing Outline

---

- **Decision Making Paradigm**
- **Problem Domain**
- **Solution Concept**
- **Technologies**
  - **Peircean Reasoning**
  - **Knowledge Representation**
  - **Modal Logics**
  - **Neo-cortical Model**
  - **Co-evolutionary Models**
- **Wrap-up**



# Decision Making Fundamentals

---

- **Knowledge**
  - Tactical skills, technical understanding, adversarial capabilities, capabilities of his force, etc.
- **Data / Information**
  - Adversarial disposition of forces (numbers, locations), weather, terrain, etc.
- **Belief**
  - Convolution of knowledge and information.
    - Basis for situational projections
    - Basis for decisions
  - Influenced by
    - Data / information uncertainty
    - Risk aversion

# Command & Control Model

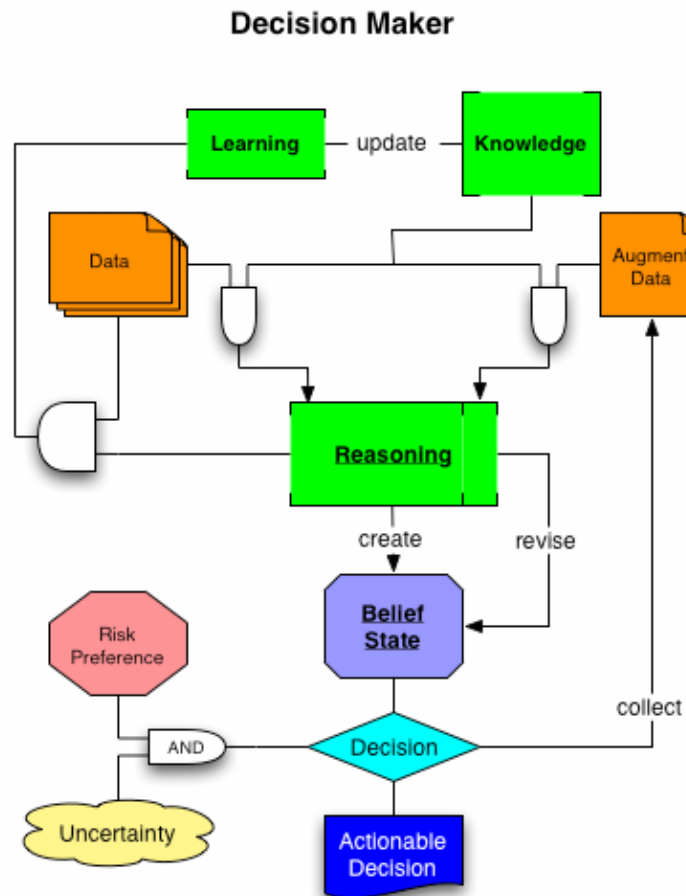



# Problem Domain

---

- **IED Threat Space.**
  - **IRA bombing campaign analogue.**
  - **Antagonists adjusting to each others tactics.**
  - **Not amenable to “pattern matching” technologies.**
- **Problem is a multi-sided game in which all sides evolve a dominant strategy.**
  - **i.e. co-evolutionary game theory with n evolving players.**



# Solution Concept

---

- **Co-evolutionary framework**
- **Reasoning Engines**
  - **Modified evolutionary game theoretic**
  - **Peircean reasoning**
    - **Abduction, deduction, & induction**
- **Knowledge Representation**
  - **Formal Concept Analysis (FCA)**
    - **Strong mathematical foundations**
      - **Ordered set theory, lattice theory**

# Architectural Graphic

## Game Theoretic Environment

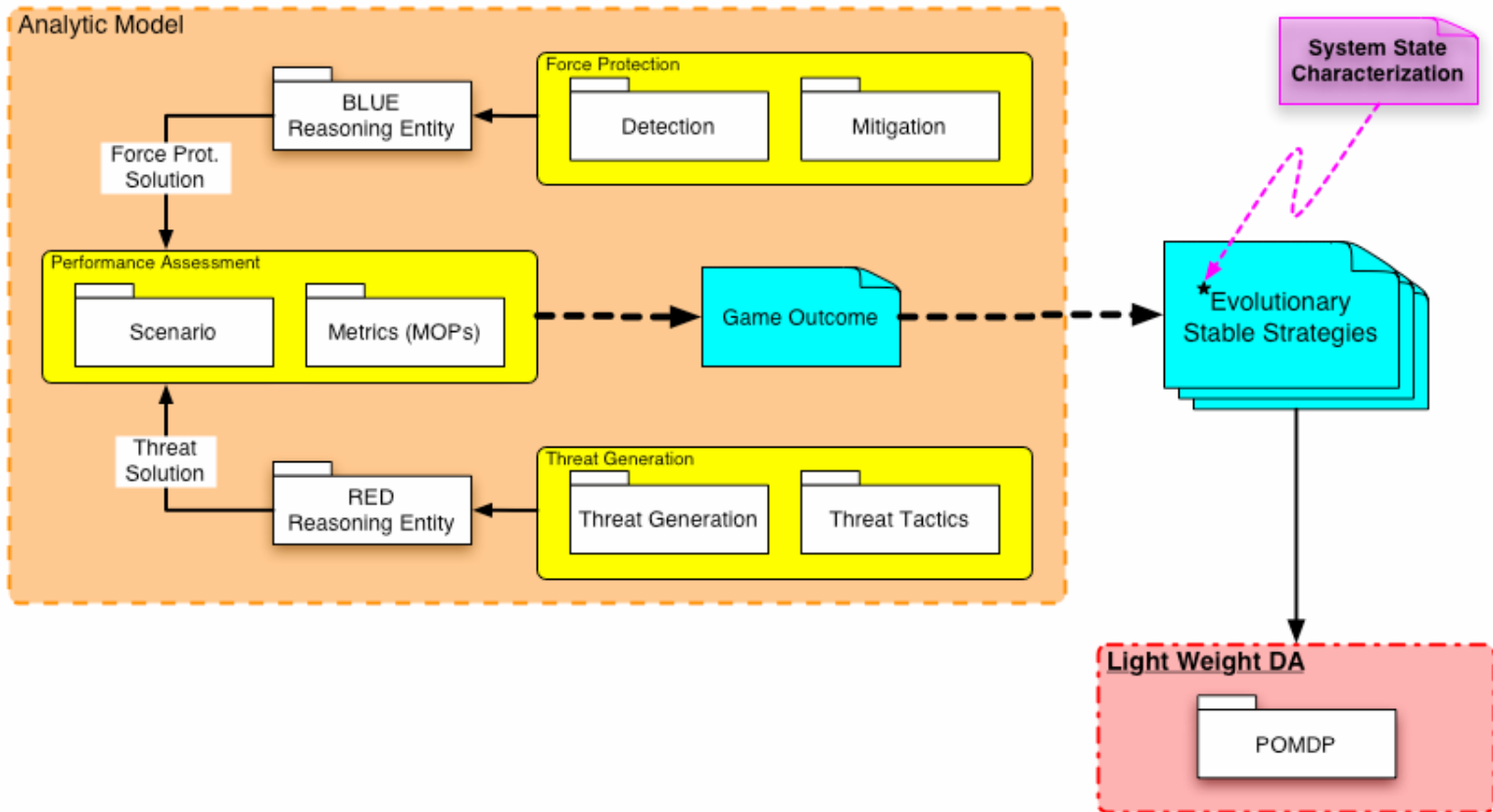



# Technologies

---

- **Peircean Reasoning**
  - Logic of reasoning
  - Reasoning operators
- **Knowledge Representation**
- **Modal Logics**
- **Hawkin's Neo-cortical Model**
  - Physical manifestation of philosophically based Peircean reasoning.
- **Co-evolutionary Models**
- **Fusion**



Reasoning consists of the formulation of a hypothesis through abduction, from which a series of experiments are postulated using deductive techniques. The results are inductive evidence used to verify or confirm the hypothesis.

### Peircean System of Reasoning

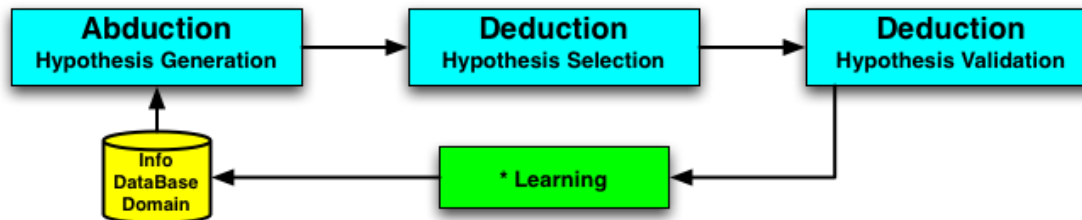

\* Basic Peircean Model with Ed Nozawa's cognitive interpretation.



# Peirce's Reasoning Model

---

- **Deduction**
  - The argument which shows a necessary connection between premises and the conclusion.
    - Logical deduction has its basis in mathematical reasoning.
- **Induction**
  - Draws a rule from the results of sample cases.
    - Three types: crude, quantitative, and qualitative.
      - Crude: Denying an event because it seldom happens.
      - Quantitative: Arguments based on a random sample.
      - Qualitative: Involves the verification or confirmation of a hypothesis.
- **Abduction**
  - The formulation of hypotheses, the process by which we arrive at plausible explanations of unique events.
  - **Analogic**
    - The formulation of hypotheses through analogy.

# Peircean Reasoning Logic

## Components of Peircean Reasoning

### Deduction

$$\begin{array}{l} \text{Any } M \text{ (} \begin{array}{c} \text{is} \\ \text{is not} \end{array} \text{) } P \\ \text{(} \begin{array}{c} \text{Any} \\ \text{Some} \end{array} \text{) } S \text{ is } M \\ \bullet \bullet \text{(} \begin{array}{c} \text{Any} \\ \text{Some} \end{array} \text{) } S \text{ (} \begin{array}{c} \text{is} \\ \text{is not} \end{array} \text{) } P \end{array}$$

### Induction

$$\begin{array}{l} \text{Any } M \text{ (} \begin{array}{c} \text{is} \\ \text{is not} \end{array} \text{) } P \\ \text{(} \begin{array}{c} \text{Any} \\ \text{Some} \end{array} \text{) } S \text{ (} \begin{array}{c} \text{is not} \\ \text{is} \end{array} \text{) } P \\ \bullet \bullet \text{(} \begin{array}{c} \text{Any} \\ \text{Some} \end{array} \text{) } S \text{ is not } M \end{array}$$

### Abduction

$$\begin{array}{l} \text{(} \begin{array}{c} \text{Some} \\ \text{Any} \end{array} \text{) } S \text{ (} \begin{array}{c} \text{is} \\ \text{is not} \end{array} \text{) } P \\ \text{(} \begin{array}{c} \text{Any} \\ \text{Some} \end{array} \text{) } S \text{ is } M \\ \bullet \bullet \text{Some } S \text{ (} \begin{array}{c} \text{is} \\ \text{is not} \end{array} \text{) } M \end{array}$$



# Reasoning Operators

---

## J.S. Mill's Canons

Method of Agreement

Method of Differences

Indirect Method

Method of Residues

Method of Concomitant Variations



# Knowledge Representation

---

- **Formal concept analysis**
  - **Mathematical foundations**
    - **Ordered set theory**
    - **Lattice theory**
  - **Transformations of concepts into other dimensions**
    - **Galois transformation**
    - **Kuznetsov's chemical grouping research**
  - **Readily extensible**

# Alternative FCA Representations

- **Formal Concept Analysis**
  - Context is expandable.
    - E.g. “Animals”
  - Orthogonal dimension of a context can capture different functionality.
    - IED: construction, detection, mitigation.

- **Lattice or Matrix representation**
  - Columns represent features
  - Rows represent concepts

Note: Lattice reading rule:

- Object possess attributes above it, if there are lines connecting the object and attribute.
- E.g. Lion attributes {preying, mammal}

Feature Matrix

Animals	Preying	Flying	Bird	mammal
Lion	x			x
Finch		x	x	
Eagle		x	x	
Hare				x
Ostrich			x	

FCA Lattice

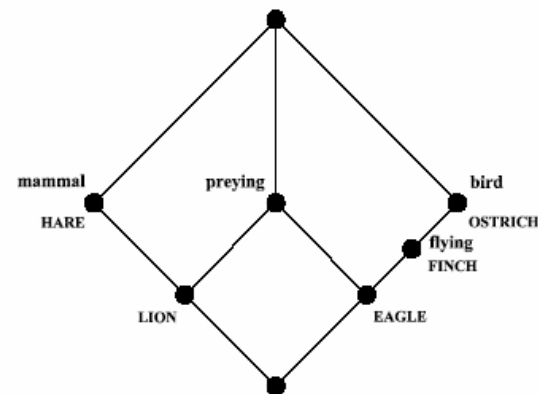

# Unique Strengths of FCA

- **Extensible**
  - New Information can be integrated into existing lattice.
  - Addition of Bat & Bee
- **Decomposable or modular**
  - Male-female & age
- **Mathematical foundations in Lattice Theory**

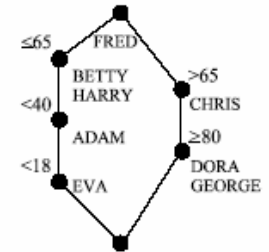
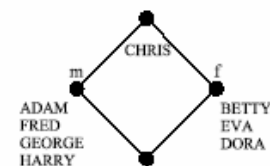
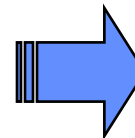
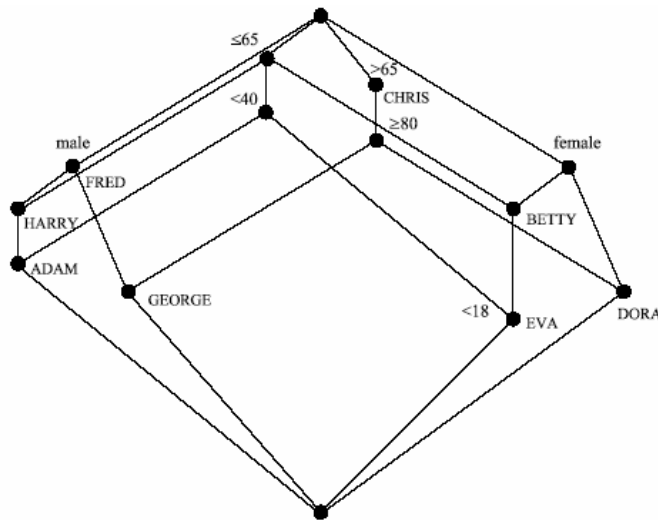
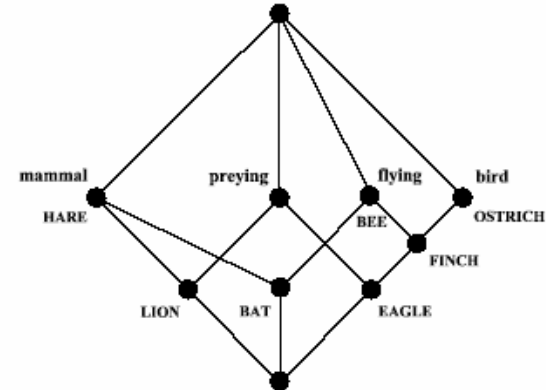



# Logic's Role in Information Ops

---

- **Provides a framework for operations on and with information.**
  - **Algebra / Calculus of information combinatorics.**
    - **Defines permitted operations and transformations.**
- **Multiple Logics.**
  - **Modal logics address many dimensions of information.**
    - **Knowledge, belief, morality, time.**
- **Provide a basis for revision and update.**





# Sample Modal Logics

---

- **Modal Logics Applicable to Information processing**
  - (theoretical basis for information operations / functionality!)
- **Epistemic Logic**
  - Basis for treatment of Knowledge
    - Tactical, Operational, Strategic skills
- **Doxastic Logic**
  - Basis for treatment of Belief
    - Decision making
- **Deontic Logic**
  - Basis for the handling of moral issues
    - ROEs
- **Temporal Logic**
  - Dealing with temporal aspects of information



# Logic / Reasoning

---

- **Logic foundations**

- **K** ~ Knowledge
- **B** ~ Belief
- $\Box$  = ~ “logically valid”
- $\alpha, \beta$  represent blocks of information/knowledge
- $\perp$  ~ logical contradiction

- **Update and Revision**

- Principles 7-11
- Contraction & expansion operators
  - “-”, “+”, “\*”
  - “\*” expansion under consistency

*(Consistency)*

*(Veridicality of Positive Introspection)*

*(Veridicality of Negative Introspection)*

*(Positive Introspection)*

*(Negative Introspection)*

## Veridicality of Knowledge

$$(1) \models K(\alpha \rightarrow \beta) \rightarrow (K\alpha \rightarrow K\beta)$$

$$(2) \models B(\alpha \rightarrow \beta) \rightarrow (B\alpha \rightarrow B\beta)$$

$$(3) \models K\alpha \rightarrow \alpha$$

$$(4) \models K\alpha \rightarrow B\alpha$$

$$(5) \text{ if } \models \alpha, \text{ then } \models K\alpha$$

$$(6) \text{ if } \models \alpha, \text{ then } \models B\alpha$$

$$(7) \neg B\perp$$

$$(8) BB\alpha \rightarrow B\alpha$$

$$(9) \neg B\perp \rightarrow (B\neg B\alpha \rightarrow \neg B\alpha)$$

$$(10) B\alpha \rightarrow BB\alpha$$

$$(11) \neg B\alpha \rightarrow B\neg B\alpha$$

Ref. Lindstroem & Rabinowicz



# Neo-Cortex Model

---

- **Abstraction Levels**
- **Feed Back Loops**
- **Linkage Between Regions**
- **Parallels to Peircean Reasoning**
- **Architecture(?)**

# Neo-Cortical Model (Hawkins)

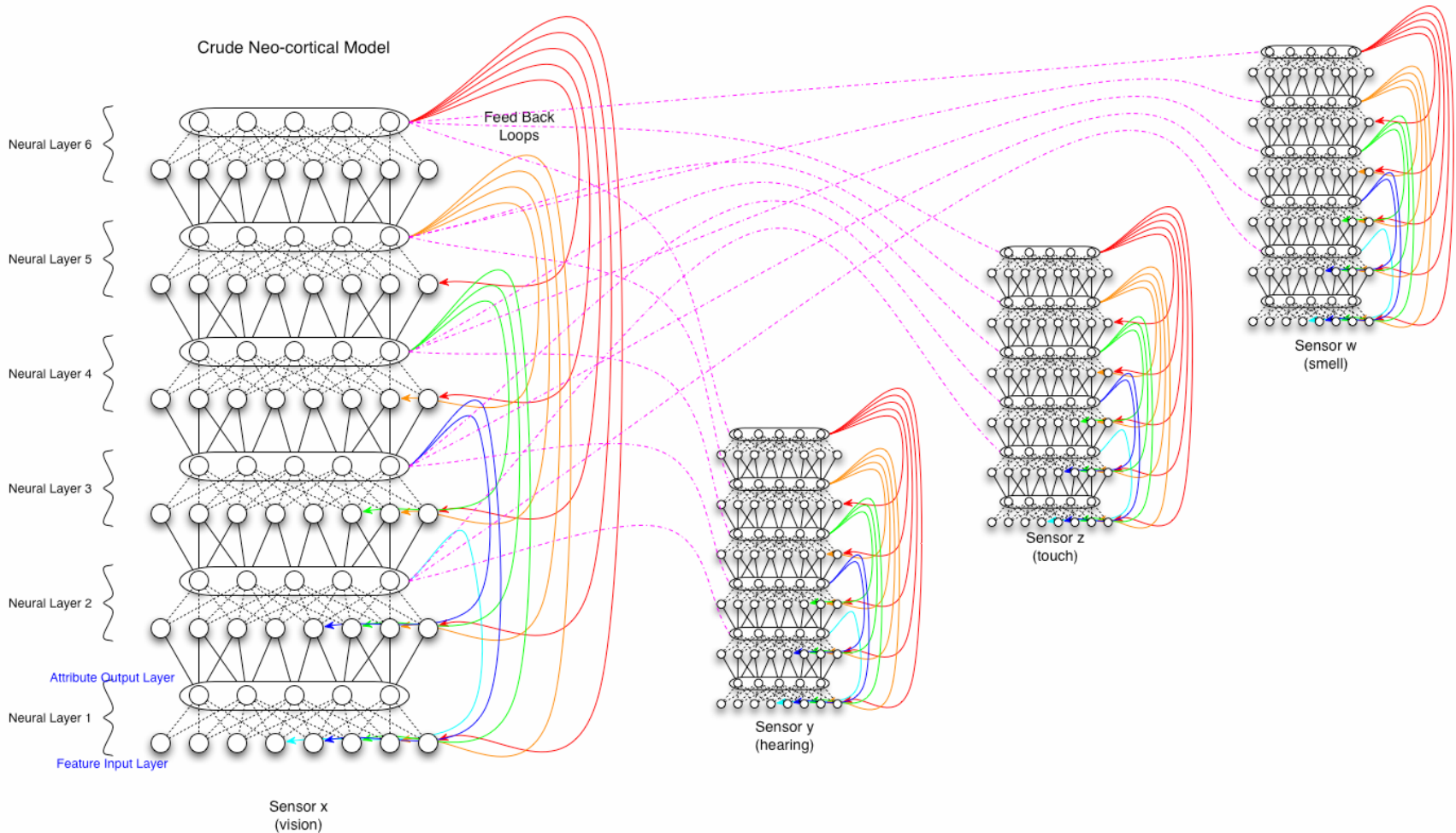

# Architecture for Reasoning

Hybridization of J. Hawkins concept of the neo-cortex, NEAT neural net technology, and formal concept analysis (FCA)

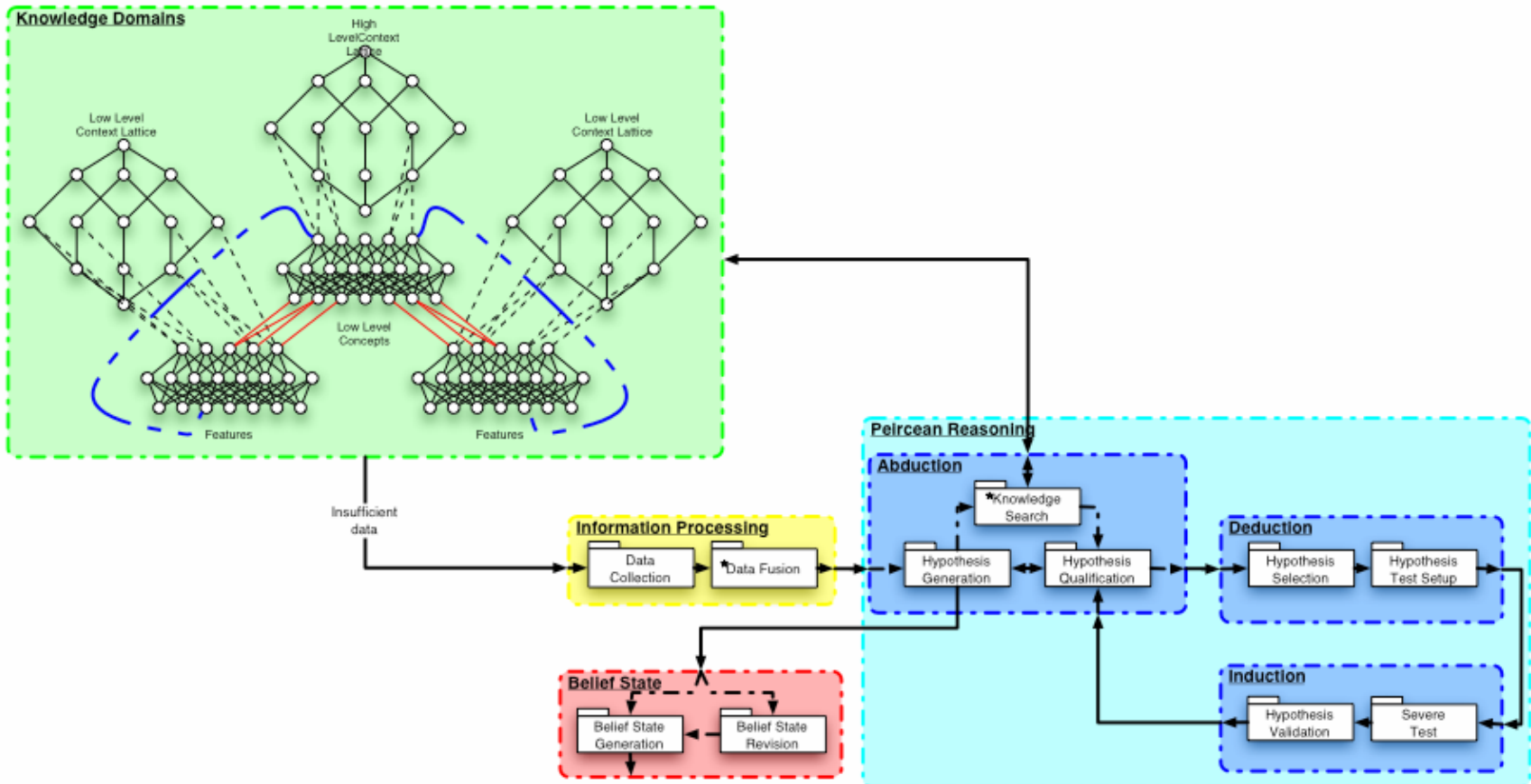



# Game Theory

---

- **Essentials of Game theory**
  - **Non cooperative game.**
    - **With pure and mixed strategies.**
  - **Game is played one time.**
    - **Can have many players.**
  - **Payoff matrix defines results.**
    - **Payoff matrix provides a basis for selecting game strategies.**
  - **Nash equilibrium.**
    - **Characteristic that emerges in mixed strategy games.**



# Evolutionary Game Theory

---

- **Essentials of Evolutionary Game theory.**
  - Non cooperative game.
  - Played many times.
    - “Players” are randomly drawn from a population.
    - Each member of the population can have a unique strategy.
  - Evolutionary process impacts the population from which players are drawn.
  - No guarantee that the ultimate strategy will lead to a Nash equilibrium.



# Co-Evolutionary Game Theory

---

- **Multi-sided game in which all sides evolve a dominant strategy.**
  - Is evolutionary game theory with  $n$  evolving players.
- **Objective**
  - Provide basis for an automated system to search for optimal solutions against adaptive opponents.



# Architectural Graphic

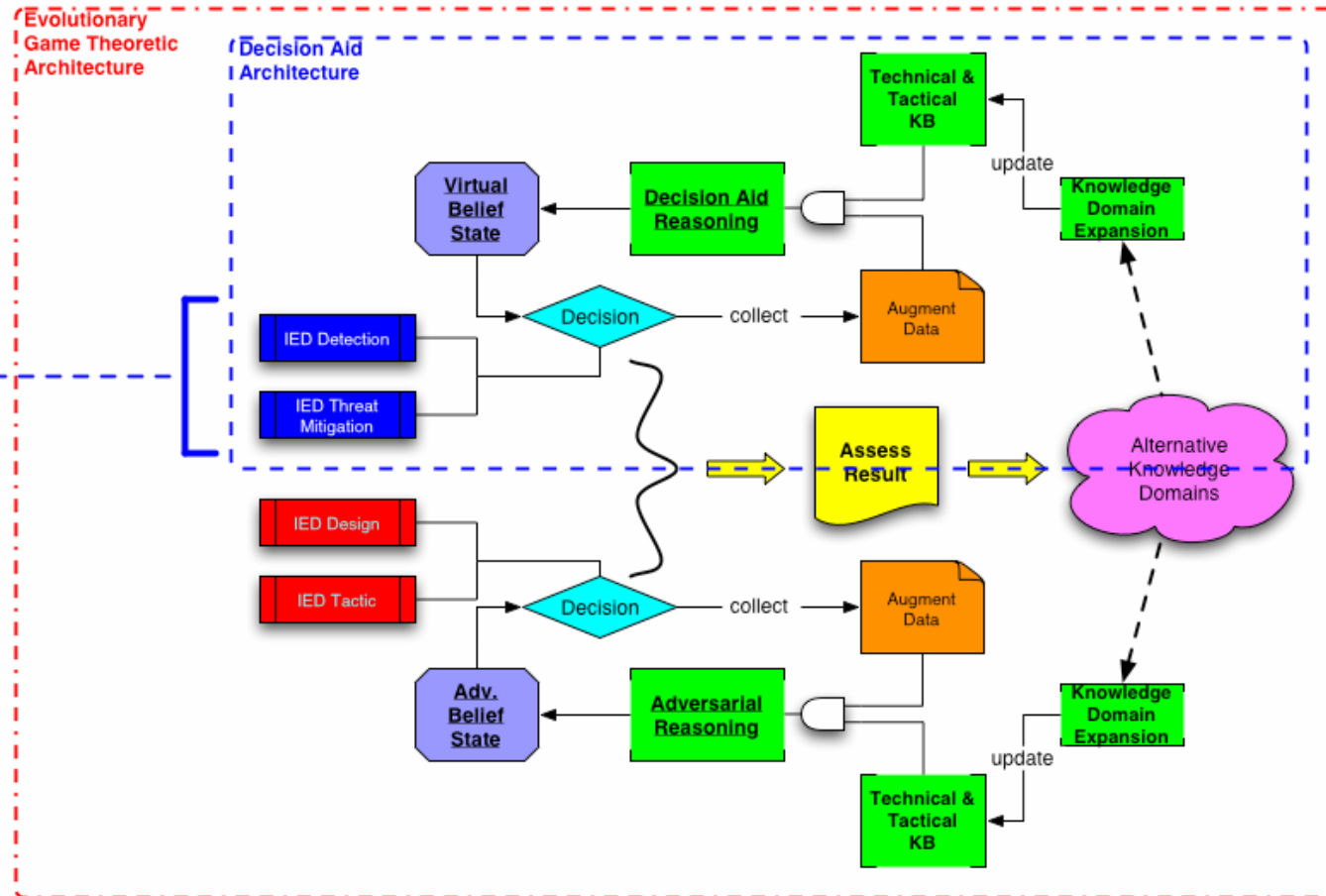



# Fusion

---

The foundations of fusion system designs must be rooted in an understanding of and the replication of human reasoning.



# Fusion Systems

---

- **Elements required of a DA, support Fusion Solutions**
- **Theoretical Foundations of Fusion**
  - **Peircean Based Reasoning**
    - Provides the basis for tailoring fusion design solutions.
  - **Modal Logics**
    - Defines the “algebra/calculus” of information combinatorics.
  - **Knowledge Representation (FCA)**
    - Defines the “currency” of information operations.
  - **Neural Paradigms (J. Hawkins)**
    - Provides a basis for architectures needed for fusion solutions.
- **Fusion Levels**
  - **Conventional definitions**
    - An arbitrary construct based on the information pyramids.
  - **Generic interpretation**
    - Enables solutions custom fitted to functional requirements.
      - Abduction, deduction, induction, pragmatism,...



# Conclusion(s)

---

- **Systems View of Decision Aid Design.**
  - Identified relatively untapped research domains.
  - Identified a decision making construct for use in the design process.
  - Identified fundamental deficiencies in our approaches for dealing with massive information infusion.
- **We must move beyond reactive solutions.**
  - The abductive component is imperative in the domains of unconventional warfare and current terrorist environments.
- **We have found a potential approach that links the physical with the philosophical.**
  - In the process we believe we have identified the model which needs to be applied in the design of data and information fusion systems.



# Backup Slides

---



---

## Information has “value” when convolved with a system.

Information possesses temporal and spatial value or worth.

The dynamics of information can not be assessed isolated from the system employing that information.

Philosophically, in isolation can information have value?



# Information Fundamentals

---

- **Information / data functionality.**
  - It is: collected, transported, transformed, stored and utilized.
- **Information has “value”**
  - Information is temporally and spatially dependent.
- **Information supports the command decision making process.**
  - When convolved with knowledge it forms the basis of a belief state which provides the foundation for decisions.
- **Information is a systems integration medium.**
  - Complex combat systems exhibit this characteristic.



# Why Bother With Modal Logic ?

---

## Algebraic Rules

Distributive Law ???

$$\left. \begin{array}{l} 3x+1 = 7 \\ \text{or} \\ 3(x+1) = 7 \end{array} \right\} \longrightarrow x = 2$$

Associative Law ???

$$\left. \begin{array}{l} (x + 2) + 1 = 6 \\ \text{or} \\ x + (2 + 1) = 7 \end{array} \right\} \longrightarrow \begin{array}{l} x = 3 \\ \text{and} \\ x = 4 \end{array}$$

Are you ready to fly on a plane designed under these “rules”?





# Peircean Philosophical Contributions

---

- **Reasoning Model (Peirce)**
  - **Model of scientific inquiry**
    - **Technical systems engineering model defined in MIL-STD499A**
  - **Abduction (Analogic), Deduction, Induction**
  - **Peirce’s “semeiotic”**
    - **Grammar**
      - **The study of what must be true for signs**
    - **Critical Logic**
      - **The study of the conditions of the proper use of signs**
    - **Formal Rhetoric**
      - **The study of the formal conditions under which signs can be communicated, developed, understood, and accepted**