

Course of Action Development and Evaluation*

Lee W. Wagenhals and Alexander H. Levis

System Architectures Laboratory,

C3I Center MSN 4D2,

George Mason University

Fairfax, VA 22030

<lwagenha>, <alevis>@gmu.edu

Tel: 703 993 1712; 703 993 1619 Fax: 703 993 1708

Abstract

This paper describes a set of procedures that will enhance the analysis, synthesis, and execution of courses of action (COA). The paper presents a set of formal methods for extending the capability of probabilistic models (influence nets) to produce rigorous mathematical models that reveal the impact of the sequence and timing of actionable events on the outcome and effects desired in a situation. By incorporating timing information, such a model can be converted to a Discrete Event System (DES) model in the form of a Colored Petri Net. The DES model, when run as a simulation, can reveal the changes in the likelihood of the desired effects over time for any timed sequence of actionable events that comprise a COA. The paper presents DES analysis techniques that can generate all of the possible sequences of probability values of the outcome given any COA without simulation. Procedures are presented to select desirable sequences from the set of all sequences and determine the temporal relationship among the actionable events that will generate a selected sequence of probability values.

1. Introduction

In our modern world, complex situations arise that require the coordinated actions of many resources to achieve desired outcomes or *effects*. The first step in dealing with these complex situations is to develop and select a *Course of Action* that will lead to a desired outcome. A Course of Action is composed of a timed sequence of *actionable events*. In current practice, probabilistic models that relate causes to effects are used to identify the set of actionable events that yield the greatest likelihood of achieving the desired outcomes and effects. Note that no timing information is provided by these models. The selected set of actionable events is provided to planners who use experience to select, assign, and schedule resources to perform task that will cause the actionable events to occur. The schedule of tasks with the assigned resources constitutes a plan. Outcomes, in terms of effects, are critically dependent on the timing of the

* This research was sponsored in part by the Office of Naval Research under Grant No. N00014-00-1-0267 and in part by the Air Force Office of Scientific Research under contract No. F 49620-98-0-0179.

Report Documentation Page

Form Approved
OMB No. 0704-0188

Public reporting burden for the collection of information is estimated to average 1 hour per response, including the time for reviewing instructions, searching existing data sources, gathering and maintaining the data needed, and completing and reviewing the collection of information. Send comments regarding this burden estimate or any other aspect of this collection of information, including suggestions for reducing this burden, to Washington Headquarters Services, Directorate for Information Operations and Reports, 1215 Jefferson Davis Highway, Suite 1204, Arlington VA 22202-4302. Respondents should be aware that notwithstanding any other provision of law, no person shall be subject to a penalty for failing to comply with a collection of information if it does not display a currently valid OMB control number.

1. REPORT DATE 2000		2. REPORT TYPE		3. DATES COVERED 00-00-2000 to 00-00-2000	
4. TITLE AND SUBTITLE Course of Action Development and Evaluation				5a. CONTRACT NUMBER	
				5b. GRANT NUMBER	
				5c. PROGRAM ELEMENT NUMBER	
6. AUTHOR(S)				5d. PROJECT NUMBER	
				5e. TASK NUMBER	
				5f. WORK UNIT NUMBER	
7. PERFORMING ORGANIZATION NAME(S) AND ADDRESS(ES) George Mason University, System Architectures Laboratory, C3I Center, Fairfax, VA, 22030				8. PERFORMING ORGANIZATION REPORT NUMBER	
9. SPONSORING/MONITORING AGENCY NAME(S) AND ADDRESS(ES)				10. SPONSOR/MONITOR'S ACRONYM(S)	
				11. SPONSOR/MONITOR'S REPORT NUMBER(S)	
12. DISTRIBUTION/AVAILABILITY STATEMENT Approved for public release; distribution unlimited					
13. SUPPLEMENTARY NOTES The original document contains color images.					
14. ABSTRACT					
15. SUBJECT TERMS					
16. SECURITY CLASSIFICATION OF:			17. LIMITATION OF ABSTRACT	18. NUMBER OF PAGES 18	19a. NAME OF RESPONSIBLE PERSON
a. REPORT unclassified	b. ABSTRACT unclassified	c. THIS PAGE unclassified			

actionable events which is determined in the planning process without the use of the probabilistic models.

In the military context, US Forces are undertaking a wide spectrum of operations ranging from Major Theater War (e.g., the Gulf War) to Humanitarian Operations / Disaster Relief. The US Forces are expected to operate with coalition partners and with domestic, foreign, and international non governmental organizations (NGOs). In Military Operations other than Conventional War, there is need to develop multiple Courses of Action to respond quickly to changing situations. The increase in tempo, the proliferation of sensors, the enhancement of communications has pointed to the need to integrate planning and execution. The wide visibility of operations is forcing near real time effects assessment with concomitant consideration of alternative courses of action. Since Desert Storm, the concept of integrated Planning and Execution is becoming accepted and systems and procedures are being implemented to achieve it (e.g., concepts are being tested in Advanced Warfighting Experiments by the Services). Integrated Planning and Execution enables dynamic battle control, (sometimes referred to as dynamic re-planning). Bosnia and especially operation Allied Force in Kosovo have focused broad attention on effects-based planning and effects assessment (see Washington Post, Sept. 20-22, 1999). This leads to closer interaction of intelligence and planning: intelligence is not only an input to the process, but is a key component of the effects assessment feedback loop. Given the potential complexity of future situations and the many consequences of the responses, an approach is needed that (a) relates actions to events and events to effects; (b) allows for the critical time phasing of actionable events for maximum effect, and (c) provides in a timely manner the ability to carry out in near real time trade-off analyses of alternative COAs. This paper presents such an approach and illustrates how new technology can be applied to assist in effects based operations.

2. Background

In the traditional command and control environment, developing, selecting, planning, and implementing specific courses of action to achieve objectives and goals are accomplished by a team of experts. The team, comprised of intelligence analysts, operational planners, logisticians, and operational controllers, collaborate in a series of at least four activities. These activities include analysis of the situation, selection of a specific course of action, developing the operational plans to implement the COA, and directing, coordinating and controlling the execution of the plan.

In the first activity, intelligence analysts, by observing the environment and assessing the situation, develop models that attempt to assess potential events and outcomes based on incomplete and uncertain understanding of both physics-based and perception-based processes. The intelligence analysts may have to rely on incomplete and sometimes inaccurate information collected via surveillance and reconnaissance activities that are sorted and stored in a variety of databases. Often they create probabilistic models based on the stored information to suggest what outcomes might occur given sets of controllable actions and uncertain exogenous events. These models are used in the second activity, where the intelligence analysts review sets of controllable actions that will comprise the COA and select the ones that they believe provide the

best chance of achieving the desired objectives. The selected COA is an input to the third type activity, planning. The planning activity uses detailed models and algorithms for planning when and how to use available assets to implement the COA. This activity is performed by operational planners who have expertise in the employment of the resources. The output of the planning function is directives to the assets so they can prepare for and execute the COA. During execution, the fourth activity, operational controllers monitor and control the COA making real time adjustments to the actions as needed. A commander (or supervisor in a business context) oversees all activities, providing guidance and approvals as appropriate.

Effects Based Operations

In the traditional approach to military operations, tasks are proposed by specialists and are sorted, selected, and prioritized so military assets can be selected to accomplish those tasks. Presumably these tasks are nominated based on a strategy that will result in accomplishing the overall objectives of the military operation. During the process of selecting and scheduling military resources to perform the tasks, and during the execution of the plan, the metric for measuring success has been the number or percentage of tasks that have been successfully completed. In the Air Force, the phrase “bombs on target” represents this concept of effectiveness. Recently, it has been recognized that this type of metric can become de-coupled from the overall objective or effects that the military action is designed to achieve. The notion of "effects based" operations has arisen that will provide a direct relationship between planned military actions and the objectives or effects that are desired. This paper addresses this notion, specifically defining the types of models that can be used for effects based operations and describing how to use these models to support collaboration between situation analysts, operational planners, and the operational controllers who develop and execute these plans.

Situation Modeling

In the current practice, complex political, economic, and military situations are analyzed and evaluated using a combination of models and simulations. Many of the models deal with well known, physics based systems, where classic discrete or continuous dynamical models can be created to evaluate the behavior or performance of systems over a range of stimuli. Detailed models of integrated air defense systems that can be used to determine the expected attrition of air strikes, or define the best suppression techniques, are readily available. But many aspects of situations involve phenomena that are difficult or impossible to model by precise, classic, physics-based models. Decision and policy making and command and control processes of nations or organizations, and intelligent systems are examples of such phenomenon.

Recently, the use of probabilistic models has been incorporated in the analysis of such processes and their role in political, economic, and military situations. In particular, Bayesian networks and variants called influence nets have been incorporated in the analysis of situations. In a Bayesian net or influence net, the nodes of the network represent hypotheses or propositions and the arcs represent direct dependency relationships between the hypotheses. Conditional probabilities are associated with the nodes of the net that encode the strengths of the dependencies. Algorithms have been developed that efficiently compute new values of all the variables whenever any variable value is specified.

Influence Nets

One of the challenges in creating a Bayesian net is that a large number conditional probability values must be assigned. To extend their use to subject matter experts who are unfamiliar with probability theory or are unable to spend resources and time to fully specify a Bayesian net, Rosen and Smith [1996] incorporated Causal Strength Logic [Changet al., 1994] into a Unix based application called the Situation Influence Assessment Module [SIAM, 1998]. When a situation requiring positive action arises, a team of SMEs can create an influence net model to identify the set of actionable events that collectively have the maximum positive influence on the objectives modeled in the network. Analysts create the influence net model of a situation using three types of nodes (hypotheses). The first are nodes that represent the effects or objectives that are desired as the result of actions to be taken. Each of the second type of node models the action or actionable event that may directly or indirectly influence or cause the objectives to occur. The third type of node is the intermediate node. These nodes model propositions that provide influencing links between the actionable events and the objectives. The SMEs specify the cause effect relationships between the nodes of the influence net and specify the strength of each relationship using qualitative measures. SIAM converts these qualitative inputs into conditional probability values that can be used to update the marginal probabilities of the net including the objective nodes given probability values of the input actions. Once the model is constructed, pressure point analysis is performed which identifies the actions that collectively have the most desired impact on the objectives. This set of actions represents the un-sequenced and un-timed elements of a COA.

Four observations can be made.

1. The current probabilistic equilibrium models (Influence nets) used for situation assessment contain a great deal of information in the form of beliefs about the relationships between events and the ultimate outcome or effect. They have an underlying rigorous mathematical model that supports analysis.
2. They provide only a single probability value for a given set of actionable events. They do not capture the effect of the sequence or timing of the actionable events.
3. Given the information that they contain and the method of construction, it seems that it is possible to enhance these model so that the impact of timing of the inputs on the outcomes/effects can be determined.
4. This impact could be represented by the timed sequence of changes in the likelihood of the outcomes/effects determined by the timing of the actionable events. The sequence of changes in probability is called the *probability profile*.

Indeed, this concept was tested and proven when a conversion algorithm was developed that takes the information contained in an influence net and converts it to a discrete event system (DES) model [Wagenhals et al., 1998]. Once timing information is added, the DES model will generate a timed sequence of probability values for the overall effect given a timed input of actionable events. The success of this conversion algorithm set the stage for a research effort to

create a comprehensive techniques for COA development and evaluation that directly addresses the actionable event timing issues.

2. Problem Statement

The problem that was addressed in the research can be summarized in the following manner. Current methods for dealing with complex situations require the development and evaluation of course of action defined as a timed sequence of actionable events. The probabilistic models used do not provide information about the impact of sequencing or timing of actionable events on the outcome/effect. The determination of timing is based on the experience of the planners and the availability of resources needed to cause the actionable events to occur. There is no analytical way to determine the impact of the timing of the actionable events on the outcomes. What is needed is a rigorous method for determining the impact of the timing of actionable events on the outcomes plus a method for determining the timing of the actionable events that will produce any particular probability profile.

The following hypotheses were established to guide the research.

- A method can be developed that uses the information contained in the influence nets to produce rigorous mathematical models that reveal the impact of the sequence and timing of actionable events on the outcome and effects desired in the situation.
- If timing information is incorporated with an influence net, a formal method can be developed to convert it to a Discrete Event System (DES) model in the form of a Colored Petri net (CP net).
- Such a DES model, when run as a simulation, can reveal the changes in the likelihood of the desired effects over time for any timed sequence of actionable events (COA).
- Using standard analysis techniques, the DES model can generate all of the possible sequence of probability values of the outcome given any COA.
- Procedures can be established to discriminate and select desirable sequences from the set of all sequences.
- A procedure can be devised that will determine the temporal relationship among the actionable events that will generate a selected sequence of probability values.

The remained of this paper highlights the procedure that was developed that satisfies the problem statement and evaluates the hypotheses. The next section briefly describes influence nets and how timing information can be associated with them. The resultant Discrete Event System view is described in Section 4 along with a high level description of the conversion technique in Section 5. The conclusions from State Space Analysis of the DES model is presented in Section 6 followed by a description of an approach to generating all of the possible probability profiles given a set of actionable events. Section 7 describes the technique for determining the temporal relationships between the actionable events that will generate a specific probability profile. Section 8 discusses the process of selecting “good” probability profiles. Section 9 illustrates

how the techniques can be used in the collaborative process of developing selecting and implementing a COA. Sections 10 and 11 provide conclusions and areas for further research.

3. Definition of Influence Nets

An Influence net is a directed acyclic graph with M nodes and E a set of directed arcs. Figure 1 provides an example.

Let M be the set of nodes representing Boolean variables

- m_j is a parent of node m_i if there exists an arc from m_j to m_i
- Π_i is the set of parents of m_i
- For each m_i with parents, there is a conditional probability $P[m_i | \Pi_i]$

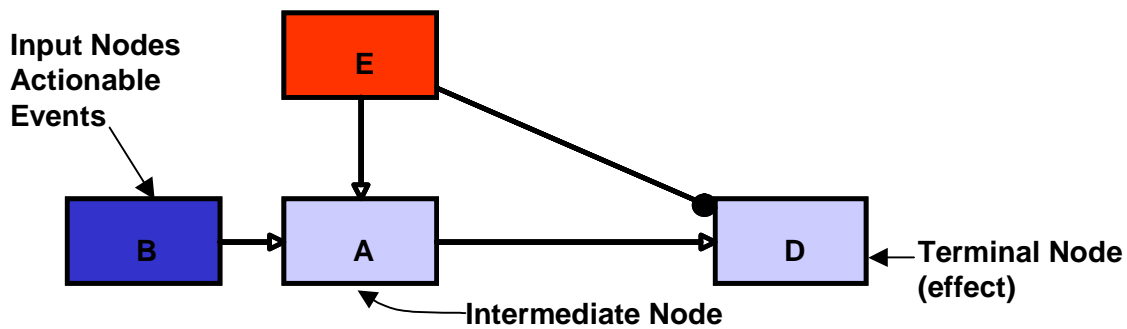

Figure 1 Example of an Influence Net

The arcs in the Influence net represent causal relationships between nodes. To use the influence net to determine the effect of actionable events, a forward propagation of probability is used to determine the likelihood of effects (usually nodes with no children) based on the occurrence of controllable causes (nodes with no parents). To implement this propagation, the marginal probability of each node m_i is calculated using the following equation:

$$P[m_i] = \sum_{k=1}^{2^n} \left[P[m_i | \Pi_i]_k \times \prod_{\pi_j \in \Pi_i} P[\pi_j] \right]$$

Incorporating Timing Information

A fundamental premise of this research that in creating an influence net of a situation, the causal influencing mechanisms are realized by a real world phenomenon to which a time delay may be associated. In many cases, influence nets model the effects of command and control or distributed decision making processes. In these models, the nodes are either actionable events or propositions about the results of a C2 process. The actionable events, the source nodes in the influence net, can be associated with a time stamp. The nodes representing propositions about the results of a C2 process can be grouped into three categories. The first are propositions about

sensors; they are either sensor events (a radar detects an aircraft) or the state of a sensor (the radar is operating). The second category contains propositions about decisions, (the leader decides to negotiate or issues the launch command). The probability of a proposition about a decision changes when the probability about propositions that influence that decision change. The third category of propositions concerns actions (a missile is launched, an aircraft is shot down, etc.). In the C2 system, the evidence of the truth or non-truth of a proposition is transferred from one process to another over some transfer mechanism such as a communications channel or courier system.

The strategy is to incorporate knowledge about the time delays of the mechanisms into the model based on the structure of the influence net that will reflect the concurrent and distributed nature of the underlying process. The resultant model will generate a timed sequence of probability changes of each proposition for a given set of timed initial causal events: a probability profile of the change in the likelihood of a proposition as a function of time. Thus a probability profile is composed of a set of time windows. In each time window, there is a probability that the proposition about an event or state is true. The probability is based on the state of the evidence in the model during the time window, specifically the state of the probabilities of the set of parents of the proposition.

Because influence nets assume the independence of causal influences, it is possible to associate time with the arcs of the influence net. These times represent the amount of time it takes for knowledge about a change in the status of any variable to be propagated by some real world phenomenon to the node that is affected by that change. Thus, we associated time delays with the arcs representing the influence in the influence net. The update in the marginal probability of a node occurs immediately after the time delay. Figure 2 illustrates the concept. This is the influence net shown in Figure 1 with time delays associated with the arcs. A time line is shown in the figure that indicates when various updates occur. Assume both events E and B (both actionable events) occur simultaneously at time zero. When Events E and B occur, both nodes A and D receive the updates in one time unit and node D receives an update about node A one time unit later. Node A gets a second update after five time units and node D receives the resultant update about node A one time unit after that.

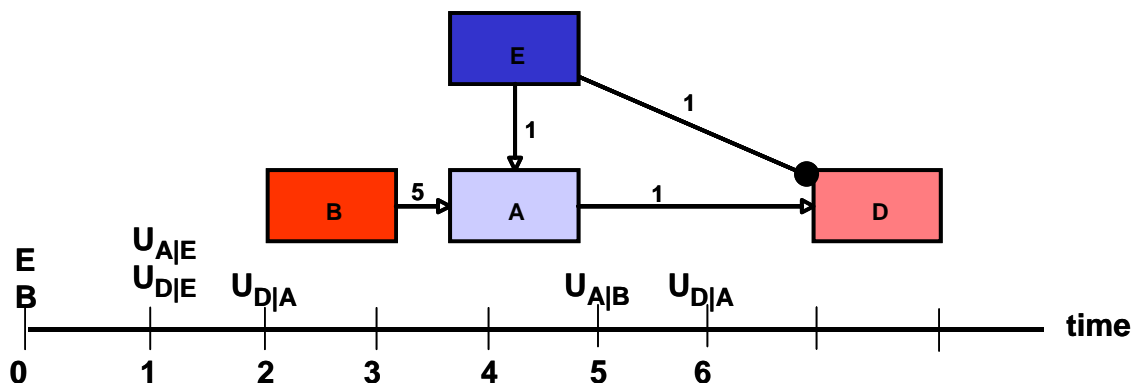

Figure 2 Associating Time with an Influence Net

4 Discrete Event System View

Once time has been added to the influence net, it represents a dynamic system composed of a set of distributed processes. This new model can generate a probability profile for each node in the net including nodes that represent to prime objectives in the situation. Each probability profile consists of a timed sequence of probability values for the node. Both the probability values and the timed sequence are dependent on not only the certainty of the actionable events, but also on the temporal relationships between those events. The final values in the sequences are the same values provided by the standard untimed influence net. The intermediate values in the probability profile are interpreted as the probability of the proposition being true during the time interval of that value in the profile. This concept is shown notionally in Figure 3 and can be described formally as follows.

- Let M be the total number of nodes in the influence net partitioned into input, output, and intermediate nodes.
- Let the *State* of the system be the set of marginal probabilities of the nodes, $P[m_i]$.
- Let an *event*, $e \in E$, be the updating of a $P[m_i]$.
- Consider input, U , and output, Y , spaces composed of the set of probabilities of the input and output nodes.
- *Initial state*: Same as the equilibrium model with $U = 0$.
- *Admissible inputs*: During an input episode, each actionable event occurs at some time, therefore, each element of U changes once from zero to one.
- There is a single final state, regardless of the sequencing of the actionable events, that is the set of probability values computed by the static equilibrium model with all input nodes set to one.

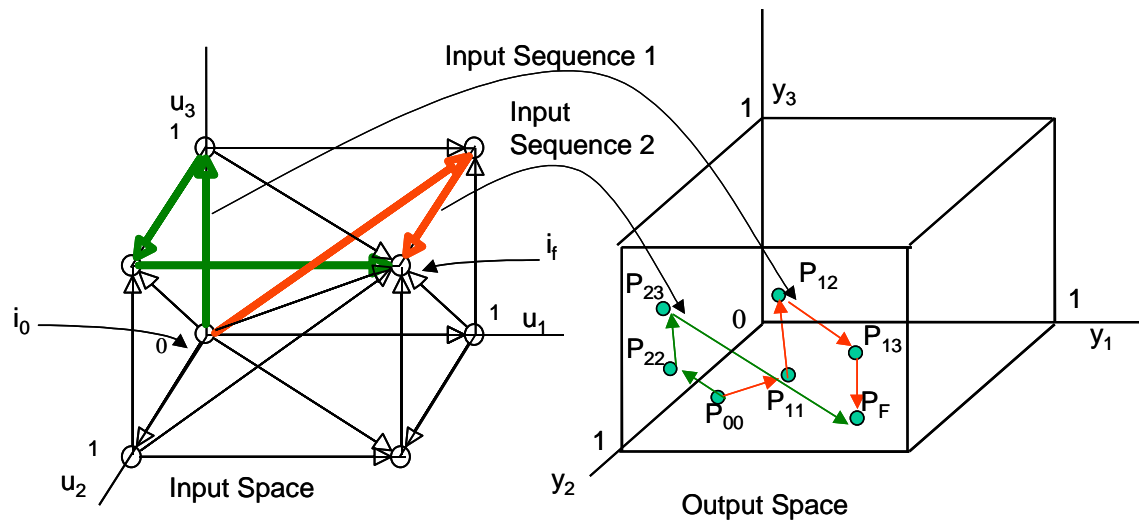

Figure 3 Discrete Event System View of Influence Net with Timing

5 Conversion of Influence Net to a Discrete Event System Model

As mentioned in Section 1, a procedure has been developed to convert an influence net with timing information into a Discrete Event System model. Colored Petri Nets (CP nets) [Jensen, 1997] were used as the DES system model using the software application, Design/CPN™ [http://www.daimi.au.dk/designCPN]. Figure 4 illustrates the conversion of a three node influence net to the CP net. Each node in the influence net is converted to a module that is a CP net and the modules are interconnected. The CP net is a bipartite directed multi-graph. This means it is a directed graph with two types of nodes, places (ovals) and transitions (rectangles). Arcs go between nodes of different types. Tokens can reside in the places. In CP nets, the tokens can have attributes with values.

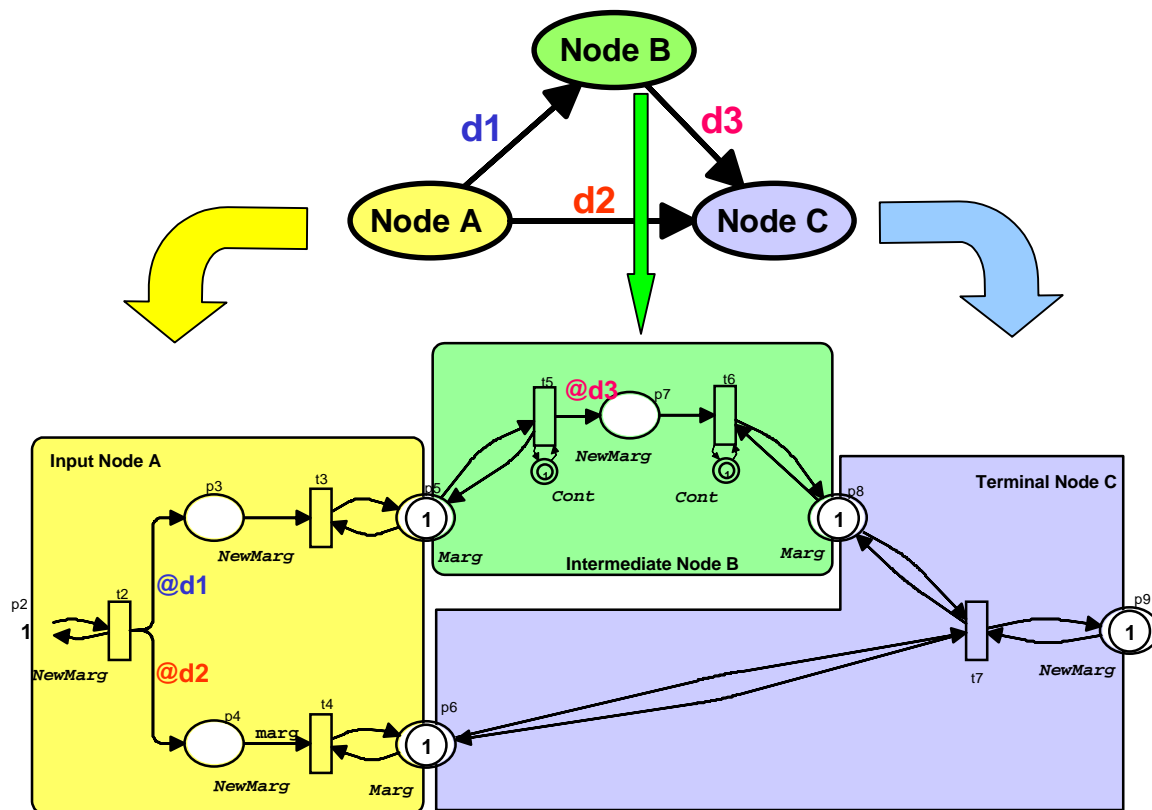

Figure 4 Conversion of Influence Net to a CP Net

A DES is a discrete state, event driven system whose evolution depends on the occurrence of asynchronous discrete events [Cassandras, 1993]. From a given initial state, all of the possible future states can be represented as a reachability tree, sometimes called an occurrence graph.

In a CP net, the state of the system is defined as the distribution of tokens in the CP net. One of the strengths of CP nets is that analysis can be performed with them. One type of analysis is called State Space Analysis. In this analysis, important properties of the CP net can be determined and the occurrence graph can be generated. The Design/CPN tool automates this

process [Kristensen et al., 1998]. The behavior of the DES model of the influence net was investigated using the State Space Analysis techniques. By concentrating of the values of the tokens generated in the Terminal or Objective node of the CP net, the following observations were made.

1. The set of output states can be arranged in a partial order (it is a lattice) with a single initial state and single final state.
2. The basis for the ordering is the combination of inputs to the objective node that is used in calculating the marginal probability value associated with the state.
3. Because it is a partial order, the states can be arranged in levels. There is a finite number of levels.
4. The transitions always go from one level to a lower level. Maximum and minimum values are each level can be identified (Local Extrema).
5. Every path from the initial state to the final state represents a potential sequence of probability values contained in any timed probability profile that will be generated by a set of timed inputs.
6. The number of steps of any sequence is less than or equal to the number of levels in the partial order.

These observations mean that it is possible to generate a model of all of the probability profiles of a set of actionable events in a situation using state space analysis of the CP net model of the influence net. Unfortunately, the state space of these models grows combinatorially with the size of the influence net and state space explosion may make the use of state space analysis of the CP net intractable.

6. Generating the Output State Space

To address the state space explosion problem, it was noted that the state space analysis of the CP net includes a very large number of variables that are not of interest. Indeed, we are only interested in determining the probability profiles of the objective node of the influence net represented by a single place in the CP net. An approach was formulated to generate the state space of this single node in the CP net.

The behavior of the objective node can be represented by a state transition diagram (STD). To create this representation, three steps were developed. (1) generate the states with probability values, (2) determine the events that cause the transitions between states and (3) determine restrictions on the reachability and the sequence of transitions due to the time delays of the influence net structure.

One the prime enablers of this approach is the fact that the “branchless” version of an influence net has the same behavior as the original (as long as the replicated inputs are the same) [Wagenhals and Levis, 1999]. An influence net can be converted to a “branchless” source-to-

sink path graph using a variant of the “find path” algorithm of Jin [1986]. The result is a net of concatenated joins as shown in Figure 5.

The input to the objective join can be reflected back to the input nodes of the source-to-sink path graph. The net in Figure 5 is composed of two concatenated joins, Node B and Node C, and there are three distinct paths from the two sources to the sink node. In an untimed CP net, Node C could be updated by any combination of the four marginal probabilities of Node B and the two probabilities of Node A1. There are eight possible combinations: $P[C|P[B|\neg D, \neg A2], \neg A1]$, $P[C|P[B|\neg D, A2], \neg A1]$, $P[C|P[B|D, \neg A2], \neg A1]$, $P[C|P[B|D, A2], \neg A1]$, $P[C|P[B|\neg D, \neg A2], A1]$, $P[C|P[B|\neg D, A2], A1]$, $P[C|P[B|D, \neg A2], A1]$, and $P[C|P[B|D, A2], A1]$. Each of these values is based on one of the possible combinations of the binary values corresponding to the occurrence or non-occurrence of each of the three input nodes of the source-to-sink path graph. We define the corresponding states by an encoding scheme based on the set of updates from the input or source nodes that were used to calculate the marginal probability of the state. In this case there are three, and the encoding scheme is a triple. Letting the first, second and third elements represent nodes, D, A1 and A2, respectively, the eight states are $[0, 0, 0]$, $[0, 0, 1]$, $[1, 0, 0]$, $[1, 0, 1]$, $[0, 1, 0]$, $[0, 1, 1]$, $[1, 1, 0]$, and $[1, 1, 1]$. Table 1 tabulates the states and the corresponding marginal probability values. A STD of Node C can be created by defining the transitions between states using the encoding scheme previously described. The transitions are caused by the arrival and use of updates from the source nodes in the computation of a new marginal probability value. These events are denoted in lower case. The STD of node C is shown in Figure 5.9. The concatenation of joins can be carried out as many times as necessary to create the complete source-to-sink path graph of an influence net. The main result is that the state of the objective node can always be represented by the vector s that reflects back to the decomposed source nodes.

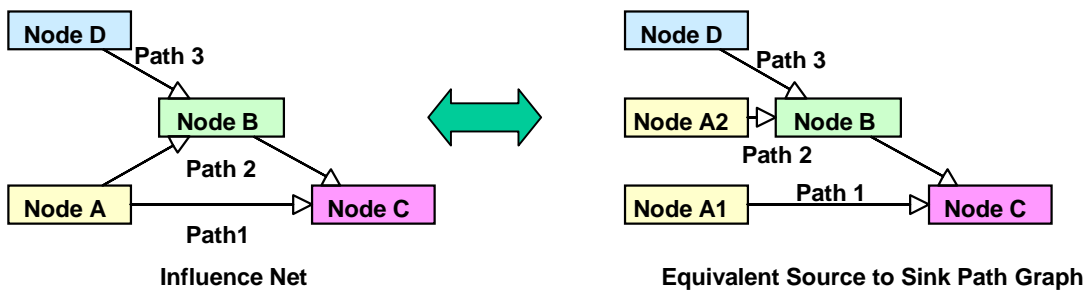

Figure 5 Creating Source to Sink Path Graph

Table 5.2 States of Node C

State $[P[D], P[A1], P[A2]]$	Marginal Probability of Node C
$[0, 0, 0]$	$P[C P[B \neg D, \neg A2], \neg A1]$
$[0, 0, 1]$	$P[C P[B \neg D, \neg A2], A1]$
$[0, 1, 0]$	$P[C P[B \neg D, A2], \neg A1]$
$[1, 0, 0]$	$P[C P[B D, \neg A2], \neg A1]$
$[1, 0, 1]$	$P[C P[B D, \neg A2], A1]$
$[1, 1, 0]$	$P[C P[B D, A2], \neg A1]$
$[0, 1, 1]$	$P[C P[B \neg D, A2], A1]$
$[1, 1, 1]$	$P[C P[B D, A2], A1]$

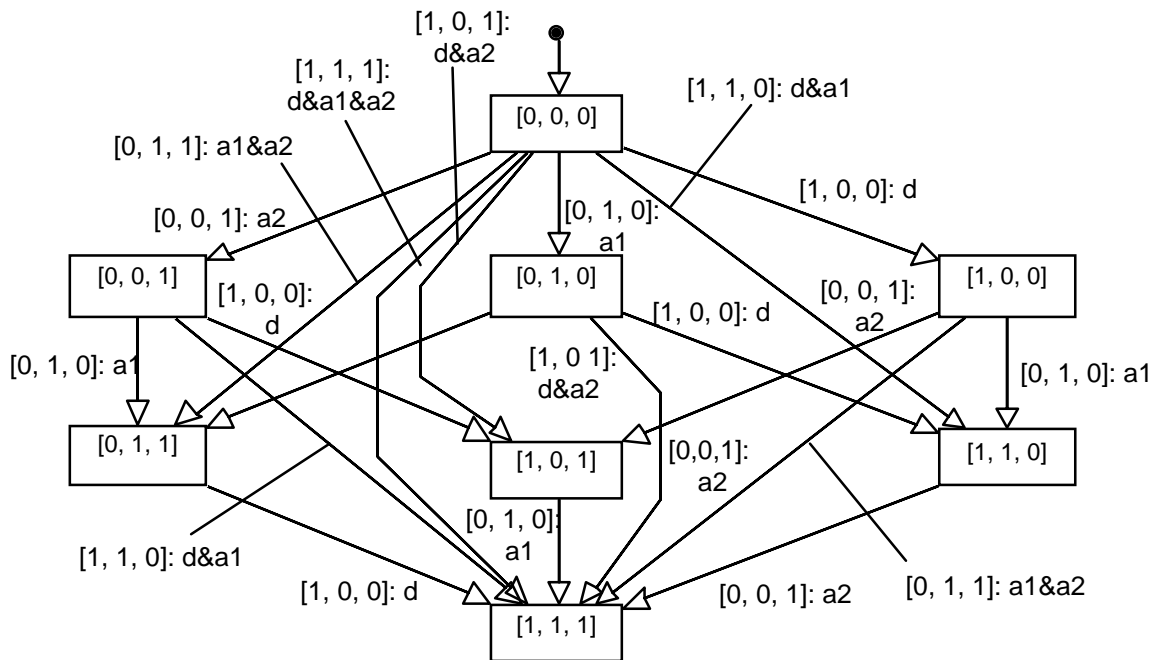

Figure 6 Full State Transition Diagram of the Influence Net of Figure 5.

Because of the time delays associated with the arcs, not all states in the untimed STD are reachable. In addition, not all paths from the initial state to the final state are feasible. A procedure, based on Timed Point Graphs [Zaidi, 1999], is used to determine the reachable states and feasible paths.

As an example, assume the four-node net of Figure 5 had path lengths of 1, 3, and 4, for paths 1, 2, and 3, respectively. The number of reachable states would be reduced from eight to six. The resultant STD is shown in Figure 7.

The set of feasible states can be arranged in a partial order (a lattice) that is based on the number of paths that have arrived at the sink node. This can be identified by the number of ones in each state. Since there are three paths in the example, there are four levels in the partial order, starting with all zeros and ending with all ones.

7 Determining Temporal Relationships Between Actionable Events

Once the final STD is created along with the set of feasible paths from initial to final state, it is possible to determine all possible sequences of the probability values that can be generated by the timed sequence of actionable events. Given that a particular sequence is desired, a procedure has been developed to determine the temporal relationship between the actionable events that will generate the selected profile. Figure 8 shows a set of Timed Point Graphs from a hypothetical influence net that has four actionable events, a, b, c, and d. The Timed Point Graph on the left shows independent chains of updates to the objective node. Assume that a path through the STD has been selected. The sequence of transitions for the path through the STD

specifies relationships that must exist between the chains of the timed point graph. For example, if the desired sequence is {a1, a2, b1, c1, a3, d1, c2, a4, b2, b3, d2}, this translates to the temporal specification {a1 < a2 < b1 < c1 < a3 < d1 < c2 < a4 < b2 < b3 < d2} and the resultant Timed Point Graph is shown on the right side of Figure 8.

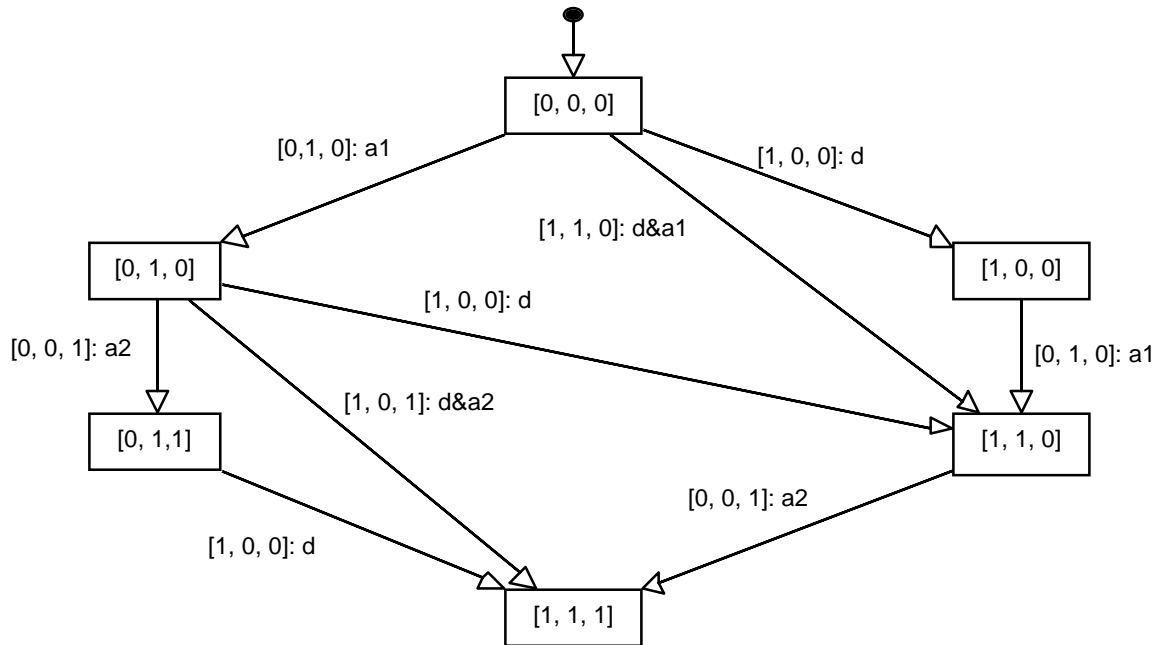

Figure 7 STD of Influence Net with Time Delays

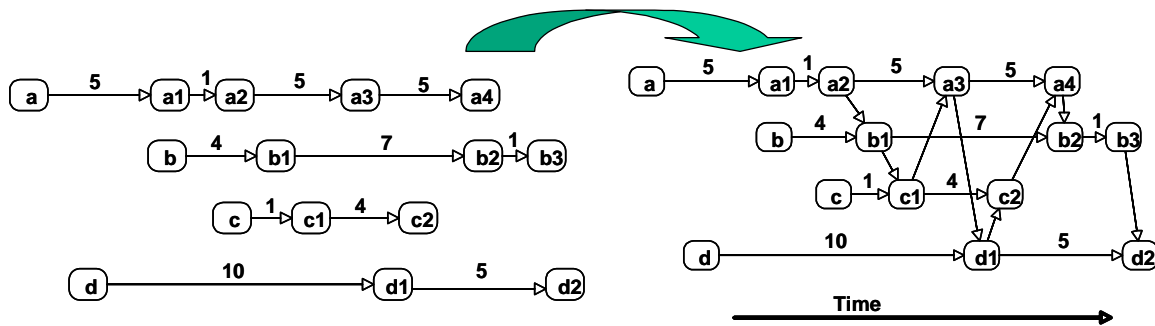

Figure 8 Timed Point Graphs

The relationship between the unconstrained chains on the left side of Figure 8 are sufficient to determine the temporal relationships between the actionable events. In the example of Figure 8, the pair wise relationships between the chains are {a2 < b1}, {b1 < c1}, [c1 < a3], [a3 < d1], {d1 < c2}, {c2 < a4}, {a4 < b2}, and {b3 < d2}.

Each of these relationships can be converted to relationships between the input nodes of each chain by substituting the equivalent time point referenced to the input node. For example, the length of the interval between node a and node a2 in the point graph is 1 + 5 = 6. This means that the time point represented by a + 6 is at the same time point as a2, and therefore, a + 6 can

be substituted for a_2 in the expression. Similar substitutions can be made for all of the time points. Table 6.1 tabulates the result of these substitutions.

Table 6.1 Conversion of Inter-Chain Relationships to Input Relationships

Original Relationship	Substitution	Input Relationships
$\{a_2 < b_1\}$	$a + 6 < b + 4$	$a < b - 2$
$\{b_1 < c_1\}$	$b + 4 < c + 1$	$b < c - 3$
$\{c_1 < a_3\}$	$c + 1 < a + 11$	$c < a + 10$
$\{a_3 < d_1\}$	$a + 11 < d + 10$	$a < d - 1$
$\{d_1 < c_2\}$	$d + 10 < c + 5$	$d < c - 5$
$\{c_2 < a_4\}$	$c + 5 < a + 16$	$c < a + 11$
$\{a_4 < b_2\}$	$a + 16 < b + 11$	$a < b - 5$
$\{b_3 < d_2\}$	$b + 12 < d + 15$	$b < d + 3$

To complete the determination of the temporal relationships, non-dominant relationships are identified and eliminated. In the example, the final set of temporal relationships is $\{b < c - 3\}$, $\{c < a + 10\}$, $\{a < d - 1\}$, $\{d < c - 5\}$, $\{a < b - 5\}$, and $\{b < d + 3\}$. Any timing of the set of input actionable events that simultaneously meets these six relationships will generate the original probability profile.

8. Selection of COAS Using A Common Planning Problem

We have now described a procedure for creating a model of a situation in which uncertainty plays an important role, that can be used to develop, analyze, and select a course of action, defined as a timed set of actionable events designed to achieve an overall effect or objective. We presented a set of tools and techniques that support this COA evaluation and selection process. This set, called the common planning problem (CPP), is comprised of five elements:

- Influence net with timing information,
- CP net model of influence net,
- STD of objective node with list of infeasible sequences,
- Timed point graph (TPGs) of the events,
- Procedure of determining COA given a sequence through the STD

As was discussed in Section 1, it is envisioned that this set of models can be the basis of a methodology used by a team composed of analysts and planners charged with the responsibility of analyzing a situation, developing an effective course of action, and developing and implementing plans for the scheduled use of resources to implement the COA.

In general, there will be a very large set of feasible sequences through the STD. Each represents an untimed probability profile. To effectively use the CPP, we need an approach for selecting good candidate untimed profiles using the STD and the TPGs so that they can be evaluated as timed probability profiles using the CP net. While this may seem to be straight forward, i.e. select the profile with the best probability values at every step, the process is more complex. This is because there is a non-fixed, non-linear mapping from each untimed probability profile to the timed probability profile. This is illustrated in Figure 9.

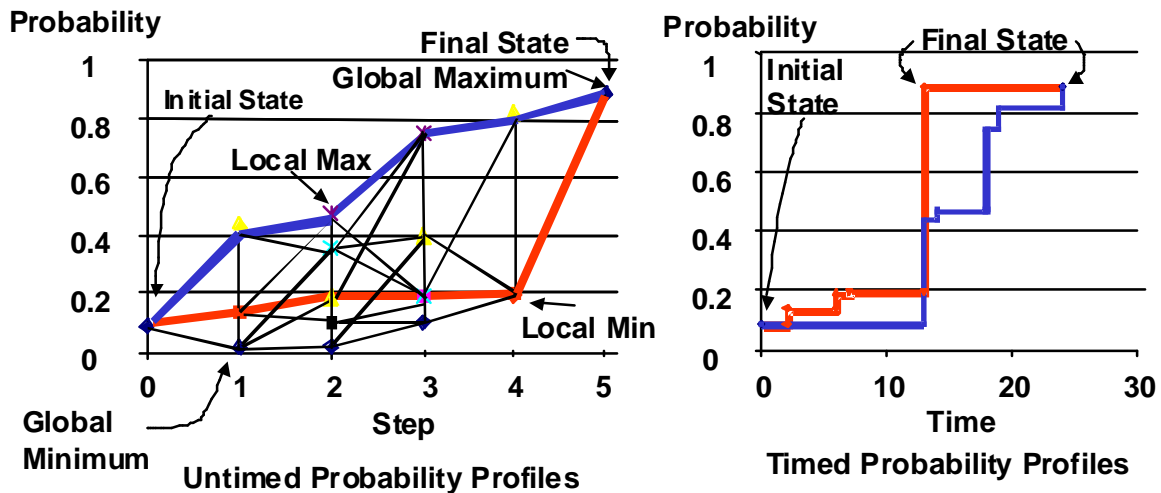

Figure 9 Non-Linear Mapping Between Un-timed and Timed Probability Profiles

The left side of Figure 9 shows a representation of the STD of an DES model of an influence net. Presented in a plot format, it shows the probability values for each state arranged in layers or steps. Several parameters that characterize the profiles are shown on the figure. There is a single initial probability value and a single final value. Highlighted is a probability profile that traverse the local maximum probability values at each step. A second probability profile is shown that traverses the middle of the plot. The timed versions of the two profiles is shown on the right side of the figure. While the profile that traverses the local maxima is always higher in the un-timed case, this is not the case in the timed profile. Indeed, one could argue that the second profile is preferred over the apparent best selection in the untimed profile.

Some characteristics of the set of untimed probability profiles (initial and final states and global extrema) map to the timed probability profiles while others only apply to the untimed profiles. For example the local extrema apply only to the untimed profile while the initial, final values and the global extrema apply to both types of profiles. Needed are parameters whose values can be determined using CPP that discriminate the timed probability profiles. Time parameters are candidates, e.g. time to final state, time to global extrema, as well as the minimum time to final state and global state. Indeed, second profile of Figure 9 was obtained by using a combination of the minimum time to global maximum and the local extrema.

9. Collaboration Using the Common Planning Problem

A team of situation analysts, operational planners, and operations controllers can use the common planning problem models and analysis techniques to develop and evaluate COAs and support effects based dynamic control of resultant plans. The concept is shown using the IDEF0 formalism [IDEF0, 1996] in Figure 10.

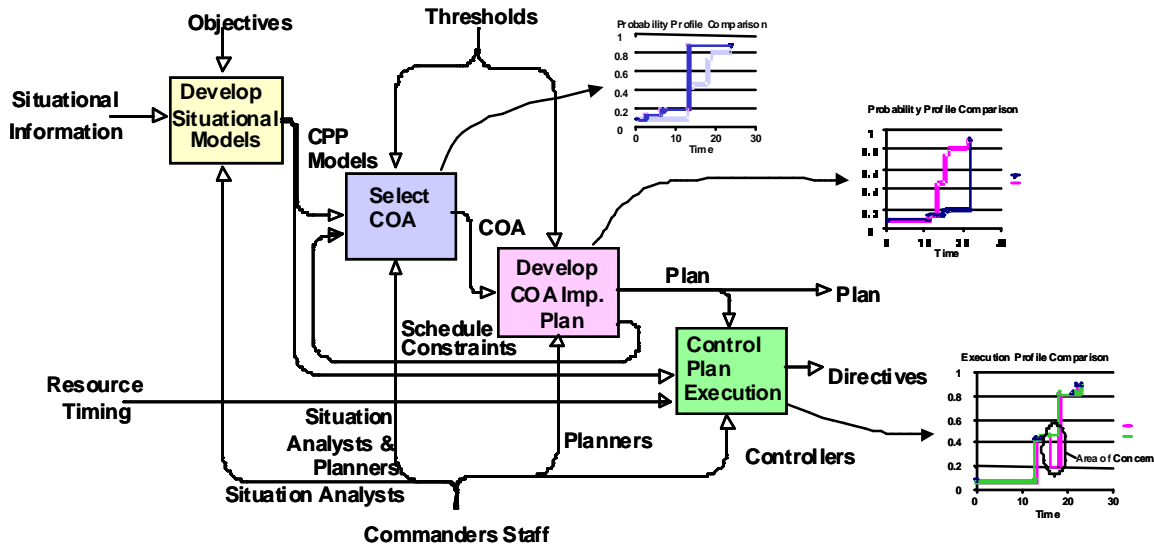

Figure 10 Using the CPP in a Collaborative Manner

The four activities described in Section 1 are shown with the members of the Commanders Staff that perform those activities indicated as mechanisms. The output of the first activity is the set of Common Planning Problem models that have been described in this paper. An initial COA is selected using the approach described in Section 8. The selected COA is provided to the team of planners who attempt to build a plan that will implement the COA. It may turn out that resource constraints prohibit the timing required by the COA. If this is the case the CPP tools can be used to refine the selection given those constraints. Once the plan has been created and approved, it is provided to the field and to the controllers for execution. During execution, the controllers can use the CPP to determine the impact that changes in scheduled actions may have on the expected probability profile. If schedule changes adversely affect the probability profile, the CPP can be used to determine the best adjustments to the COA.

10. Conclusions

We have presented a method that addresses the problem presented in Section 2. A method was developed that uses the information contained in the influence nets to produce rigorous mathematical models that reveal the impact of the sequence and timing of actionable events (a COA) on the outcome and effects desired in the situation. It has been demonstrated that by adding timing information to an influence net model it can be transformed into a discrete event system model that can be used to generate all timed sequences of probability values for any timing of the set of inputs. State space analysis techniques have been used create a set of models that comprise a common planning problem. A STD, sequence rule mode, and timed point

graphs, created using the timed influence net and the CP net, can generate all probability sequences of an objective node. A method has been developed to determine the temporal relationships among inputs that will generate any feasible untimed probability profile using a set of models that comprise the common planning problem. Together, these procedures support a vision of collaborative COA development and evaluation for effects based planning and execution.

11. Future Directions

Three areas of current research are: (a) extending the fixed time delays to stochastic time delays, (b) expanding the evaluation of untimed and timed probability profiles, and (c) incorporating feedback during plan execution for determining when to change COAs. We plan to incorporate a portion of the CPP process in upcoming demonstrations and exercises to assess the practicality of the collaborative process proposed in this paper. The first demonstration will be in Global 2000 at the Naval War College.

References

- [Design/CPN, 1999] Design/CPN Online. <http://www.daimi.au.dk/designCPN/>
- [IDEF0, 1996] Integrated Definition Language 0 (IDEF0), Federal Information Processing Standard 184, National Institute of Standards and Technology, Washington DC.
- [SIAM, 1998] *Situational Influence Assessment Module User's Guide*, Version 2.0, Science Applications International Corporation, McLean Virginia.
- [Buede and Wagenhals, 1996] Buede, D. M. and L. W. Wagenhals (1996) "Influence Diagram Representation of Dynamic, Distributed Decision Making," *Proc. Command and Control Research and Technology Symposium*, Naval Post Graduate School, Monterey CA, June 25-28, 1996.
- [Chang, et al., 1994] Chang, K.C., P. E. Lehner, A. H. Levis, S. A. K. Zaidi, and X. Zhao (1994) On Causal Influence Logic, Technical Report, George Mason University, Center of Excellence for C3I, December 3, 1994.
- [Cassandras, 1993] Cassandras, C. G. (1993), *Discrete Event Systems, Modeling and Performance Analysis*, Aksen Associates Incorporated, Boston MA.
- [Genrich, 1991] Genrich, H. (1991). Predicate Transition Nets. *High Level Petri Nets: Theory and Application*. Jensen K. and Rozenberg G., Editors. Springer-Verlag, Berlin, Germany.
- [Hershovits, 1991] Hershovits, E. (1991). Computer-Based Probabilistic-Network Construction, Doctoral Dissertation, University of Pittsburgh, Pa.
- [Jensen, F., 1996] Jensen, F. V. (1996) *An Introduction of Bayesian Networks*, UCL Press limited, London.

- [Jensen, K., 1997] Jensen K. (1997). *Coloured Petri Nets: Basic Concepts, Analysis Methods and Practical Use. Volumes 1, 2, and 3. Basic Concepts*. Monographs in Theoretical Computer Science, Springer-Verlag, Berlin, Germany.
- [Jin, 1986] Jin, V. Y. (1986) Delays for Distributed Decisionmaking Organizations, LIDS-TH-1459, Laboratory for Information and Decision Systems, MIT, Cambridge, 1986.
- [Kristensen, et al., 1998] Kristensen, L. M., S. Christensen, and K. Jensen (1998) “The Practitioner's Guide to Coloured Petri Nets,” *International Journal for Software Tools for Technology Transfer*. Springer_Verlag.
- [Mott, et al., 1986] Mott, J., A. Kandel, and T. Baker (1986), *Discrete Mathematics for Computer Scientist and Mathematicians*, Prentice Hall, Englewood Cliffs, N.J.
- [Murata, 1989] Murata, T. (1989). “Petri Nets: Properties, Analysis and Applications,” *Proceedings of the IEEE*, Vol. 77, No. 4, April 1989.
- [Peral and Verma, 1991] Pearl, J. and T. S. Verma (1991), “A Theory of Inferred Causation,” *Principles of Knowledge Representation and Reasoning: Proceedings of the Second International Conference*, Allen, J., Fikes, R. and Sandewall, E. (Eds.) San Mateo, CA Morgan Kaufmann.
- [Rosen and Smith, 1996] Rosen, J. A. and W. L. Smith (1996) “Influence Net Modeling with Causal Strengths: An Evolutionary Approach,” *Proceedings of the Command and Control Research and Technology Symposium*, Naval Post Graduate School, Monterey CA, June 25-28, 1996.
- [CPN Group, 1999] The CPN Group (1999). <http://www.daimi.au.dk/Cpnets>.
- [Wagenhals and Levis, 1999] Wagenhals, L. W. and A. H. Levis (1999), “Converting Influence Nets With Timing Information To A Discrete Event System Model, A Colored Petri Net,” *Proc. of 2nd Workshop on Practical Uses of Coloured Petri Nets and Design/CPN*, DAIMI PB-532, Aarhus University, Denmark, October, 1999.
- [Wagenhals, et al., 1998] Wagenhals, L. W., I. Shin, and A. H. Levis(1998), “Creating Executable Models of Influence Nets with Colored Petri Nets,” *International Journal for Software Tools for Technology Transfer*. Springer_Verlag, Berlin.
- [Zaidi, 1999] Zaidi, A. (1999). “On Temporal Logic Programming Using Petri Nets,” *IEEE Transactions on SMC–Part A: Systems and Humans*, vol. 29, no. 3, May 1999.