

Modeling and Simulation Support for the Standing Joint Force Headquarters Concept

**Susan G. Hutchins,¹ Gordon E. Schacher,² James Dailey,³ John P. Looney,¹
Steven E. Saylor,³ Jack J. Jensen,² John S. Osmundson,¹ and Shelley P. Gallup¹**

**¹Information Sciences Department
²Meyer E. Institute of Systems Engineering
Naval Postgraduate School,
Monterey, CA 939432
³The Boeing Company
Seattle, WA 98124-2207**

Paper for the Modeling and Simulation Track: **Paper # 366**

10th International Command and Control Research & Technology Symposium

Report Documentation Page

Form Approved
OMB No. 0704-0188

Public reporting burden for the collection of information is estimated to average 1 hour per response, including the time for reviewing instructions, searching existing data sources, gathering and maintaining the data needed, and completing and reviewing the collection of information. Send comments regarding this burden estimate or any other aspect of this collection of information, including suggestions for reducing this burden, to Washington Headquarters Services, Directorate for Information Operations and Reports, 1215 Jefferson Davis Highway, Suite 1204, Arlington VA 22202-4302. Respondents should be aware that notwithstanding any other provision of law, no person shall be subject to a penalty for failing to comply with a collection of information if it does not display a currently valid OMB control number.

1. REPORT DATE JUN 2005		2. REPORT TYPE		3. DATES COVERED 00-00-2005 to 00-00-2005	
4. TITLE AND SUBTITLE Modeling and Simulation Support for the Standing Joint Force Headquarters Concept				5a. CONTRACT NUMBER	
				5b. GRANT NUMBER	
				5c. PROGRAM ELEMENT NUMBER	
6. AUTHOR(S)				5d. PROJECT NUMBER	
				5e. TASK NUMBER	
				5f. WORK UNIT NUMBER	
7. PERFORMING ORGANIZATION NAME(S) AND ADDRESS(ES) Naval Postgraduate School, Information Sciences Department, Monterey, CA, 93943				8. PERFORMING ORGANIZATION REPORT NUMBER	
9. SPONSORING/MONITORING AGENCY NAME(S) AND ADDRESS(ES)				10. SPONSOR/MONITOR'S ACRONYM(S)	
				11. SPONSOR/MONITOR'S REPORT NUMBER(S)	
12. DISTRIBUTION/AVAILABILITY STATEMENT Approved for public release; distribution unlimited					
13. SUPPLEMENTARY NOTES The original document contains color images.					
14. ABSTRACT					
15. SUBJECT TERMS					
16. SECURITY CLASSIFICATION OF:			17. LIMITATION OF ABSTRACT	18. NUMBER OF PAGES 42	19a. NAME OF RESPONSIBLE PERSON
a. REPORT unclassified	b. ABSTRACT unclassified	c. THIS PAGE unclassified			

Modeling and Simulation Support for the Standing Joint Force Headquarters Concept

Susan G. Hutchins,¹ Gordon E. Schacher,² James Dailey,³ John P. Looney,¹ Steven E. Saylor,³ Jack J. Jensen,² John S. Osmundson,¹ and Shelley P. Gallup¹

¹Information Sciences Department

²Wayne E. Meyer Institute of Systems Engineering
Naval Postgraduate School, Monterey, CA 93943

³The Boeing Company, Seattle, WA 98124-2207

{shutchins@nps.edu; schacher@nps.edu; jim@james-dailey.com; jplooney@nps.edu;
steven.e.saylor@boeing.com; jjjensen@nps.edu; osmundson@nps.edu; spgallup@nps.edu}

Abstract

A computational model of Standing Joint Force Headquarters (SJFHQ) processes was developed using EXTEND simulation software. In this paper we describe the use of this modeling and simulation approach for analyzing time-critical information systems and performing trade studies. An object-oriented model was constructed of the processes performed by SJFHQ members and simulations were run to obtain system measures of performance. This model focuses on the planning processes performed by SJFHQ members to support the Effects-Based Planning processes and the Operational Net Assessment update. A complete four-level architecture was developed that captures all processes, sub-processes, information flows, and personnel task assignments. It includes detailed architectures and was based on US Joint Forces Command publications and subject-matter expertise. The model focuses on pre-crisis operations (where indications and warnings intimate an impending crisis for which an existing ONA has relevancy) and a SJFHQ that is integrated with a Regional Combatant Commander staff. Distributed operations with organizations outside the SJFHQ are also represented. The simulation was structured to focus on personnel issues, including individual workload levels, multitasking effects, and how these workload and personnel issues affect the overall time to perform the entire SJFHQ planning process.

1. Introduction

The Standing Joint Force Headquarters (SJFHQ) concept was introduced at the Joint Experimentation Command during Millennium Challenge 2000. The purpose is to provide a standing element that will provide information and collaboration support for Regional Combatant Commanders and/or Joint Task Forces. This element will consist of 58 people plus additional system analysis personnel (initially seven). Responsibilities for the SJFHQ are to maintain and provide information databases, collaboration capabilities, and subject-matter experts (SMEs) to assist in conducting the Effects-Based Planning (EBP) processes. SJFHQ personnel provide a core of trained experts who are essential to conduct planning using the new EBP processes.

The SJFHQ will integrate directly with any regional command structure established to manage a crisis, assist in using information from an Operational Net Assessment¹ (ONA) database, and participate in the overall command planning and decision-making cycle. Implementation of this new SJFHQ concept is expected to greatly enhance a region's command, control, communications and intelligence (C3I) processes and crisis management. SJFHQ is a new concept that has not yet been fully implemented and personnel are currently being trained to occupy these billets.

Detailed information about this organization's operation does not yet exist, such as the amount of time or effort involved to conduct all the various tasks that comprise SJFHQ responsibilities. The goal for this modeling and simulation work is to better understand personnel issues, in terms of how many people are needed to perform specific functions, what types of personnel are needed, improve the assignment of tasks to personnel, and understand the impact of workload on the time to complete the overall EBP process.

Osmundson (2002) points out that a strength of systems engineering is the ability to analyze complex systems problems in terms of fundamental parameters, formulate alternate architectural solutions, perform trade-off analyses of the alternate solutions, and select a best solution based on a reasonable set of selection criteria. Modeling and simulation of SJFHQ operations provides an efficient and cost effective means to obtain data to provide inputs to answer key questions of interest to concept developers. Information developed through SJFHQ implementation simulation runs can be used to examine details regarding SJFHQ processes and task performance and make decisions so that initial use of these units can be as efficient as possible.

There is an increasing need for application of systems engineering principles to the analysis and design of complex, expensive, and performance-critical information systems (Osmundson, 2002). A systems engineering approach was applied to produce data that will help system developers make informed decisions. The goal is to gain insight into the effectiveness of the processes as performed by the designated personnel and organizational design issues in a cost-effective manner.

2. Background

The SJFHQ is not designed as a standing Joint Task Force (JTF), but rather as a standing element that focuses on a Commander in Chief's (CINC) operational trouble spots. This knowledge-centric, cross-functional organization takes advantage of knowledge and information flow. The SJFHQ functions at the operational level of national defense as the joint C2 element to support a rapid decisive operation. When fully operational, this important and emerging C2 structure will transform the preemptive and follow-on options a unified CINC will have (U.S. Joint Forces Command, 2002). It will provide the CINC an increased range of options for crisis response within his Area of Responsibility (AOR).

The SJFHQ will provide each regional CINC an informed and in-place C2 capability. The goal is to have at least one operational SJFHQ in each regional command by FY05. It is anticipated that the SJFHQ will reduce the *ad hoc* nature of standing up today's JTF Headquarters and provide

¹Operational Net Assessment (ONA) is a product of collaboration among analysts at strategic, operational, and tactical levels. The ONA views a potential adversary as an interdependent system of systems, all of which contribute to some degree toward his societal coherence, will, and capability to pursue a course of action inimical to friendly interests.

increased stability as a result of the deep situational understanding developed prior to SJFHQ employment. The expectation is that the SJFHQ will give the CINCs an advantage of time, perhaps the most critical resource. (*ibid*) This C2 capability should enable improved pre-crisis planning on CINC-directed focus areas. For example, having a SJFHQ should provide an enhanced C2 capability based on a more timely and improved situational awareness and an augmented understanding of the adversary and friendly capabilities.

It is expected that different combatant commanders (COCOMs) will use their SJFHQ element in a variety of ways, and that SJFHQ utilization will also vary with the situation. It will be some time before a body of information is available that provides the input needed to help establish optimal manning and utilization of SJFHQ. A methodology to develop an understanding of SJFHQ implementation is needed so that initial use of these units can be as efficient as possible. Process modeling and simulation of SJFHQ operations is an efficient and cost effective means to obtain data to provide inputs to answer key questions of interest to concept developers. Simulation runs can be used to examine details regarding SJFHQ processes and task performance.

The SJFHQ modeling and simulation project, at Naval Postgraduate School (NPS), in Monterey, CA, in partnership with Boeing, developed an initial version of the simulation and produced initial runs and results. This paper provides a brief description of the steps that were taken to develop the simulation, its current status, and discussion of the way it can be used to make informed decisions about structuring the emerging SJFHQ. We also describe work needed to configure the simulation to produce more detailed implementation versions and produce additional information required by the program office.

Naval Postgraduate School supported the SJFHQ program office, RADM O'Hanlan, Joint Forces Command, by developing an executable model of the core SJFHQ processes. A complete four-level architecture was developed that captures all processes, sub-processes, information flows, and personnel task assignments. The simulation was developed using EXTEND simulation software using an advanced database approach in partnership with Boeing under an NPS-Boeing Cooperative Research and Development Agreement (CRADA). As the simulation is run, analyses focus on personnel, in particular, on work assignments, the effects of multi-tasking, and efficiencies in planning gained by having the SJFHQ as a central component of the Effects-Based Planning and Operations processes. Results of the analyses produced by the simulation model can be used by the program office to propose and examine improvements to the SJFHQ.

3. Work Accomplished

The following simulation development tasks were completed. Tasks are listed in the order they were accomplished to illustrate the logical process of simulation development.

1. Determine all SJFHQ processes.
2. Decompose processes into three levels of sub-processes, down to the individual task level.
3. Develop an SJFHQ operational architecture.
4. Vet the architecture with J89.
5. Identify tasks that are performed to accomplish these processes.
6. Determine task sequencing, interdependences, and information flow.
7. Identify the individuals, by title, who work on these tasks.
8. Define task workgroups (all processes are decomposed to the task level).

9. Develop a methodology and accompanying tables that map people, task workgroups, and processes to provide the database foundation for the simulation.
10. Develop a multi-tasking module that represents human work performance.
11. Create the baseline SJFHQ simulation.
12. Perform rigorous tests of the simulation to insure proper operation (verification).
13. Develop and report the results of simulation runs to illustrate use of the methodology.

Each of these simulation development tasks is briefly described below. Source documents for this development included: Concept of Employment, June 03, (US Joint Forces Command, 2003) and Standard Operating Procedures, October 03 (US Joint Forces Command, 2003). Detailed review of this work was provided by CDR John Looney, a subject matter expert (SME), and a former SJFHQ team member.

3.1 Determine SJFHQ Processes: The first step entailed developing an understanding of the scope of the overall processes performed by the SJFHQ. The majority of this information was obtained from the following US Joint Forces Command reference documents. Concept of Employment has chapters describing staff relationships between the Regional Combatant Commander (RCC) and SJFHQ, staff relationships between the Joint Task Force (JTF) and SJFHQ, pre-crisis planning, and how these members of the SJFHQ collaborate to conduct an ONA and EBP. Additional information included in the Concept of Employment document is included in appendices that describe the processes employed for conducting Effects Based Operations (EBO), Operational Net Assessment (ONA), and other detailed SJFHQ organization and billet descriptions.

Standard Operating Procedures is a more extensive document, which contains six chapters describing the activities of the following SJFHQ sub-organizations:

- Command Group
- Information Superiority Group
- Operations Group
- Logistics Group
- Planning Group
- Knowledge Management Team

This publication includes appendices that describe the activities of each sub-organization, including details on EBP and ONA. There is also an appendix that describes responsibilities of the following Boards, Centers, Cells, and Working Groups:

- | | |
|--------------------------------------|---------------------------------------|
| • Joint Information Superiority Cell | • Time-Sensitive Targets Cell |
| • Joint Collection Management Cell | • Logistics Coordination Board |
| • Joint Coordination Board (JCB) | • Blue/Red Cell |
| • JCB Working Group | • Joint Planning Group (at JTF level) |
| • Joint Fires Working Group | • Joint Knowledge Management Board |

Considerable interpretation of the material in these reports was needed to produce the process maps and tables that comprise the base of the simulation. In many cases the experience of the SME had to be used to provide correct interpretations. The end result is a process mapping that captures significant SJFHQ EBP process details and ONA updating operations, and places them in correct relationship to each other.

3.2 Decompose into Sub-Processes: The simulation tool used for this project, EXTEND, allows one to employ an object-oriented, hierarchical approach. This approach simplifies setting up the underlying model. Relatively few top-level process blocks are defined that capture the major operational processes undertaken. The six top-level process blocks for SJFHQ are shown in Table 1. Within each process there are a large number of tasks that must be performed. In the following section we describe how these six processes are decomposed into three levels of sub-processes. Each level of sub-processes contains logical groupings; they are similar in function, they are performed by the same personnel, they address the same tactical operation, etc. The end result is a hierarchy of processes and sub-processes that correctly represents the operation and that also provide the structure needed for the model and simulation. A general rule for doing this type of decomposition is to decompose no further than necessary for the particular study being done. Table 1 shows the processes and the number of sub-processes at each level.

Table 1. SJFHQ Top-Level Processes and Number of Sub-Processes for each Sub-Level within the Model

Process	Sub-Processes		
	Level-1	Level-2	Level-3
Command Directives	6	4	19
Effects-Based Planning	4	15	76
Operational Net Assessment	7	35	235
Collaborative Info Environment	3	3	10
Training/Exercises	3	3	15
Deployment/Logs/Transport	3	3	22

Level-3 is the task level, the level at which personnel produce information. There are 377 of these task-level sub-processes. The process table contained in the SJFHQ Simulation technical report (Schacher, Dailey, Looney, Saylor, Jensen, Osmundson, Hutchins & Gallup, 2004) presents the details of this decomposition.

3.3 Develop a SJFHQ Operational Architecture: The architecture required for process simulation utilizes components from the Department of Defense Architecture Framework (DODAF) but requires more detail. The decomposition referred to above was captured in process maps that are presented in the SJFHQ Simulation report. (Due to space limitations these tables cannot be included here.) These maps provide an easy visualization of information flow and process interrelationships. Depending on the simulation technique employed, one directly uses architecture maps or the process table to build the simulation. For the standard technique where process blocks are laid out on a visual template and connections made between them, the maps are used. For the database method reported here, the tables are used. Even so, developing the maps was a necessary step to ensure that information flow is correct, logical, and contains neither sinks (processes that have no output) nor infinite loops.

3.4 Vet the Architecture with J-89: J-89 has the mandate to develop operational architectures for the SJFHQ and JTF. It is important that the architecture developed for this project is in agreement with the SJFHQ architecture that is officially approved. Architectures developed for this project go to a lower level of detail than required by J89, thus we vetted our architectures only at the top levels.

3.5 Identify Tasks: Several different types of SJFHQ responsibilities were identified and tracked: scheduled meetings, information production, command and team decisions, information assessment, etc. Many involve sub-processes, such as producing individual, specific pieces of information. These have been broken down to individual tasks, to the level where one can identify the groups of personnel that work on them.

3.6 Determine Task Sequencing, Interdependences, and Information Flow: Processes, and their included tasks, are performed in an order such that information is produced and moves through the processes in the correct order. Some processes occur in a pre-determined sequence; some occur in parallel. This has been mapped in order to set up the simulation correctly. Maps that allow visualization of this flow are contained in Schacher, et al., 2004.

3.7 Identify Individuals, by Title, and their Associated Work Tasks: The purpose of developing the simulation is to track and measure latencies associated with personnel activities, the work SJFHQ members have on their desktops, how processing their tasks is affected by multitasking, and so on. Accomplishing this requires knowledge of the specific personnel who are assigned to each task. The reference reports show processes assigned to major groups and also the personnel within these groups. For most cases they do not specify personnel information down to the task level. SME knowledge was required to specify lower-level tasks and individual personnel assignments.

3.8 Define Task Workgroups: In order to account for task sharing among several individuals, it is convenient to define groups that are responsible for carrying out each task. These can be, but are not necessarily, groups that are defined in the SJFHQ documents. There is some artificiality in defining these task workgroups in that they are not necessarily actual operational/tactical groups. They are a modeling convenience because they provide a simple way to record personnel assignments for different SJFHQ configurations. The task workgroups to which an individual is assigned can be simply entered into a table to produce a unique configuration. At this point in the project, personnel assignments are contained in the master table presented in Schacher, et al., 2004.

3.9 Develop Maps of People, Task Workgroups, and Processes: Assignment of people to task-level sub-processes has been completed. As noted above, assignment of workgroup titles and subsequent association of these workgroups with sub-processes has not been done. This does not affect simulation operation. What is missing is a convenient graphical user-interface to facilitate database manipulation to make changes to reassign personnel.

3.10 Develop a Human Multi-Tasking Module: At the core of the simulation is the ability to model an individual performing tasks under conditions where he/ she can be interrupted by meetings or higher-priority tasks, have several tasks on their desk at the same time, and need to coordinate work with others. A module has been developed to model these human performance modalities. The simulation contains a human multi-tasking module for each of the SJFHQ personnel. A step that remains to be done is assigning individual skill levels. This will enable conducting simulation runs that take into account varying skill levels of SJFHQ members.

3.11 Create the Baseline SJFHQ Simulation: It is not possible at this time to develop a simulation that is representative of “SJFHQ reality” because such a reality does not yet exist. The baseline that has been developed contains all of the known processes and tasks that are performed by the SJFHQ organization. From this baseline, and the modular database simulation configuration, one can easily reconfigure the SJFHQ simulation to produce a simulation that

represents various realities, such as variations on SJFHQ utilization by specific Combatant Commanders (COCOMs). It is also easy to reconfigure the simulation to do “what-if” analyses.

3.12 Perform Simulation Tests: The SJFHQ simulation has been run for a range of conditions to test proper performance of task routing, the human performance module, and information passing between processes. Conditions have been set so that the work distribution causes overload and blocking of task performance at task workgroups. Task performance times have been adjusted to test process synchronization and to determine critical process nodes (processes where delays will cause significant disruptions in SJFHQ performance).

3.13 Develop and Report Results from Simulation Runs: The results produced thus far are representative of the types that can be produced and represent one step toward simulation validation. True validation cannot be done until field data is available from SJFHQ operations.

3.14 Required Future Work

The initial simulation produced is a baseline. The SJFHQ simulation methodology, structure, and analysis methods are now in place. Results that have been produced were obtained to validate correct simulation performance, not SJFHQ performance in an operational situation. Additional work needed to provide results that apply to operational situations or for program office planning are described below. We refer to steps A, B, and C below in defining follow-on work.

Step A. The baseline simulation has the following principal attributes: (1) It contains all required EBP and ONA updating processes; (2) it contains a methodology for conducting simulation runs and analysis; (3) it is modular so that rapid reconfiguration can be accomplished; and (4) it has been validated for proper operation.

Step B. A principal step in simulation development is parameterization of its process modules/blocks. Parameters most often used are: (i) processing time, (ii) process capacity, (iii) information input and output requirements for initiation and completion, (iv) information content and formats, and (v) conditions such as mandated schedules and synchronization. Strictly speaking, information content, formats, schedules, and synchronization are not process parameters, rather they are treated as process interface requirements.

Step C. Simulation results are produced in response to a set of questions or requirements. Before results can be produced, the simulation requires the following information: (1) a statement of the question(s) to be answered, (2) a set of results parameters (measures) to be produced to answer the questions, and (3) specification of the conditions under which the results are to be determined. In order to quantify data latency in an information system the analysis technique must explicitly express the system in terms of variables, or design factors that can be summed to give an overall system response time (Osmundson, 2000).

The baseline simulation containing the principal attributes (step A) is complete. Parameterization of the process modules and blocks (step B) was accomplished using the SME’s expertise, however, this parameterization is not necessarily representative of an existing or planned operational situation. Simulation results produced in response to a set of questions or requirements (step C) remains to be done. In the following section we begin with step C then proceed to step B, which is the normal method for study development. All studies require that the baseline exist, step A, which has been accomplished.

Study Definition: We envision two types of studies: (1) What-if analyses defined to meet Program Office objectives and (2) determination of the effectiveness of proposed and actual COCOM use of the SJFHQ. For the first type of study the simulation would be configured to match the what-if situation. For example, one could determine the effectiveness of adding particular types of personnel to SJFHQ, or the effectiveness of reconfiguring workgroups.

COCOMs use-effectiveness studies require a definition of the proposed configuration. SJFHQ could be fully integrated, used as a stand-alone unit, be responsible for some decisions, etc. It may be that not all 58 people (or 65 if considering System-of-System Analysis personnel) would be available, and thus the model's structure would be altered to correspond to the particular configuration.

4. SIMULATION METHODOLOGY

The SJFHQ simulation was developed with EXTEND simulation software, a highly respected off-the-shelf discrete event simulation methodology that can rapidly develop a wide range of process models (<http://www.imaginethatinc.com>). Boeing's Phantom Works group has substantial expertise in utilizing EXTEND simulation software having developed simulation analysis tools for a wide variety of military and commercial system architectures. Validated simulations have been developed for several domains, including network-centric communication systems, time-critical targeting scenarios, and resource/logistical optimization.

Models in EXTEND are structured by connecting library block components that logically describe the process or system that is modeled. EXTEND provides a library of validated base-blocks to work with and more than 95% of the SJFHQ model was developed with these standard components. These libraries were then augmented with custom block components that were developed to model a number of unique characteristics of the SJFHQ processes. These customized Boeing/SJFHQ blocks are stored and delivered in an EXTEND library file that is installed before launching the model file.

The SJFHQ model leverages EXTEND's strong hierarchical capabilities, where base library block components are further encapsulated for model organization, library storage and replication. For example, each of the 65 personnel in the SJFHQ element is represented by a Person hierarchical block (see the multiple "P" blocks in the top-level view, in figure 1). The Person h-block is added from the customized SJFHQ library and is made up of basic EXTEND library components. Note that within this Person h-block is another h-block called "Working on Assignments" which groups the model constructs for multi-tasking assignments and prioritizing of assignments by an individual. Figure 2 depicts the model construct of a Person H-block.

EXTEND is uniquely powerful in its ability to structure scenario input data within its own internal relational database. For the SJFHQ application, the simulation database structure is an EXTEND replication of the Excel spreadsheet that specifies information flow between the processes and sub-processes (for more detail on the EXTEND database see Schacher, et al., 2004). Database tables are directly (and efficiently) accessed by the model constructs during run-time. The database can then be easily modified with an alternative scenario for comparison.

The SJFHQ simulation database is used to collect specific customized outputs. As the primary objective for use of this simulation will focus on personnel utilization and time to complete tasks,

one of the principal outputs collected is personnel work hours by task. A plotter for each team member shows the number of tasks on their desk at any given time during the simulation timeline. The model also logs each “instance” of a layer that has been initiated by the model.

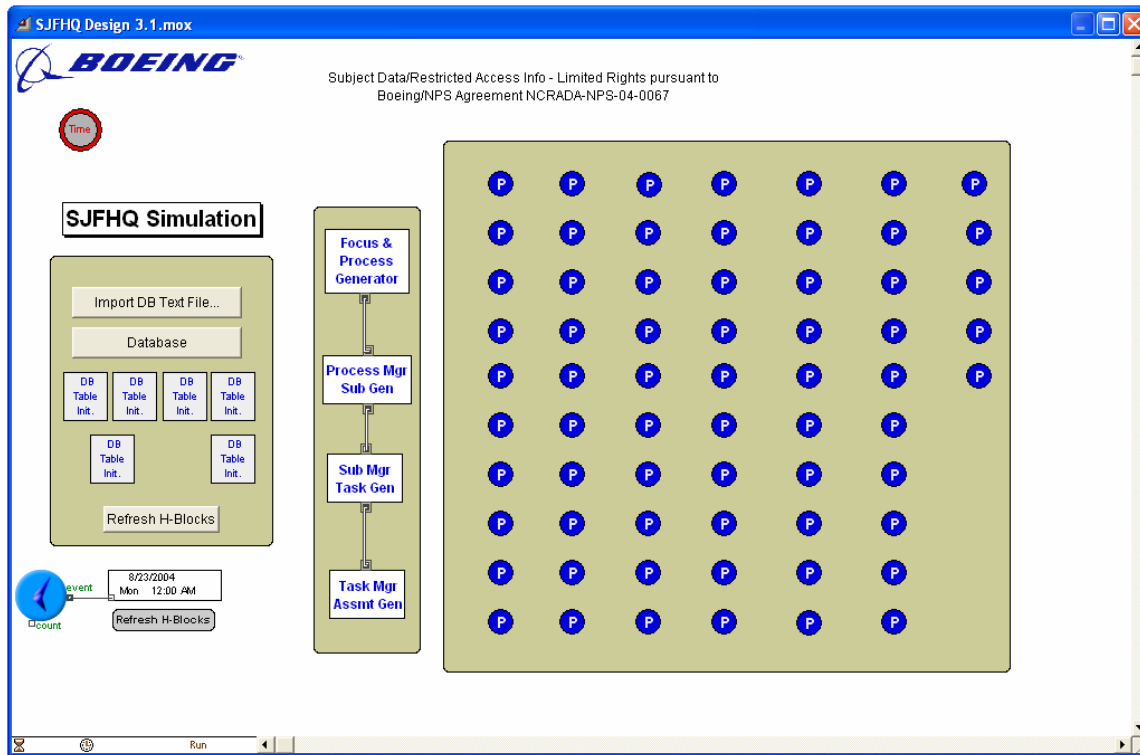
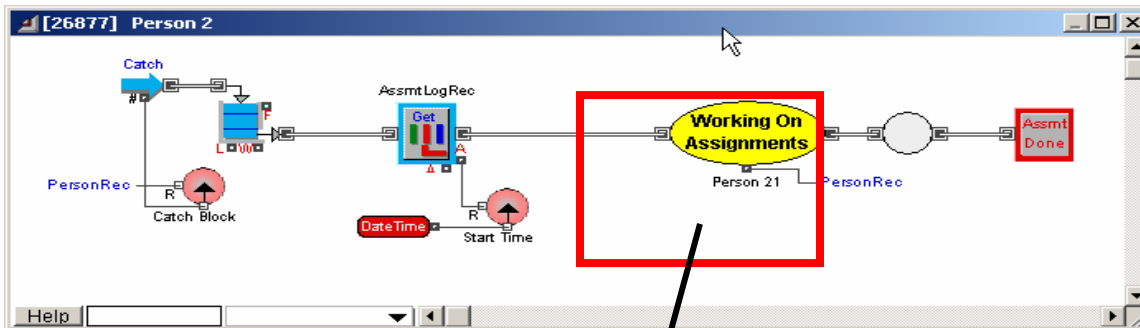

Figure 1. Top-level view of the EXTEND Standing Joint Force Headquarters Model.



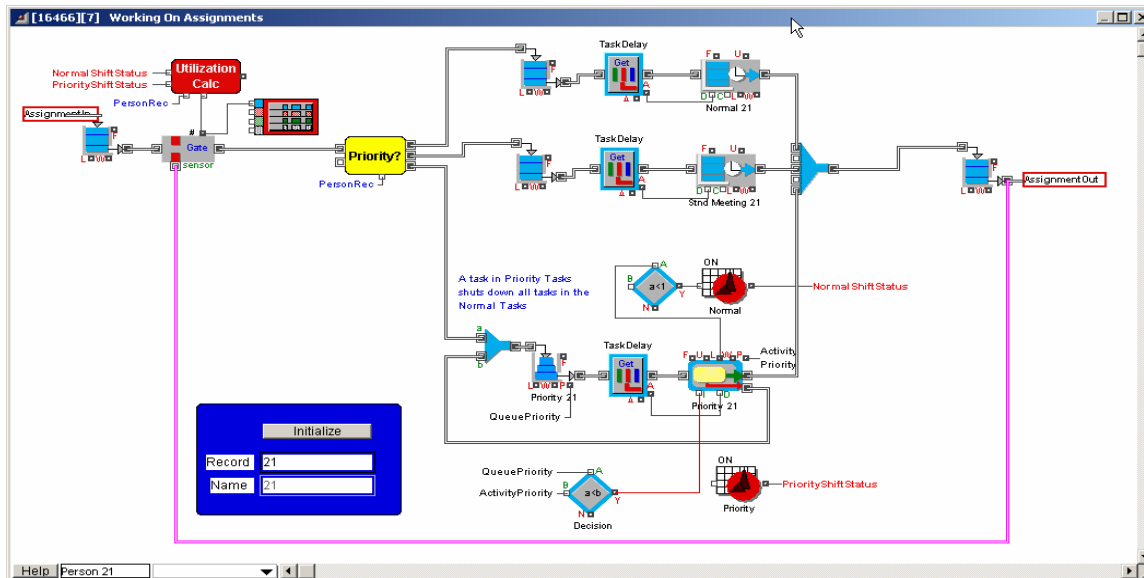

Figure 2. Model Constructs, Person H-Block.

Records in the log tables (Focus, Process, Sub-Process, Task and Assignment levels) capture start time, completion time, and show the number of hours elapsed from start to finish.

5. SJFHQ PROCESSES STRUCTURE

5.1 Core, Top-Level, Processes and Levels Structure

The six “core” processes included in the SJFHQ model and the three levels of sub-processes within each are depicted in Figure 3. Figure 3 shows the sub-process levels under Effects-Based Planning. Under each of the sub-processes in Level-1 there are a number of Level-2 sub-processes, with further decomposition down to Level-3. Sub-processes are indicated by white boxes. A logical numbering scheme for all processes and sub-processes is used to track their relationships, for example:

- 3.0 Effects-Based Planning
 - 3.2 Mission Analysis
 - 3.2.8 Determine End State Objectives
 - 3.2.8.3 Develop Recommended Priority Effects List (PEL)

Figure 3 also shows a Level-3 sub-process sending a task to a work-unit (referred to as boards, centers, cells, and work groups/units). A large number of work-units comprise the SJFHQ, the composition of each depending on the tasks assigned to them. A task can be sent to a work-unit only from a Level-3 sub-process.

To some extent a sense of time is indicated in figure 3 by the length and positions of the process bars. For example, ONA originates farthest to the left because that process is ongoing almost continuously, long before a crisis is declared. Similarly, Logistics and Transportation planning is also ongoing, although it is not as lengthy a process as ONA. Command Group Directions will initiate all other processes.

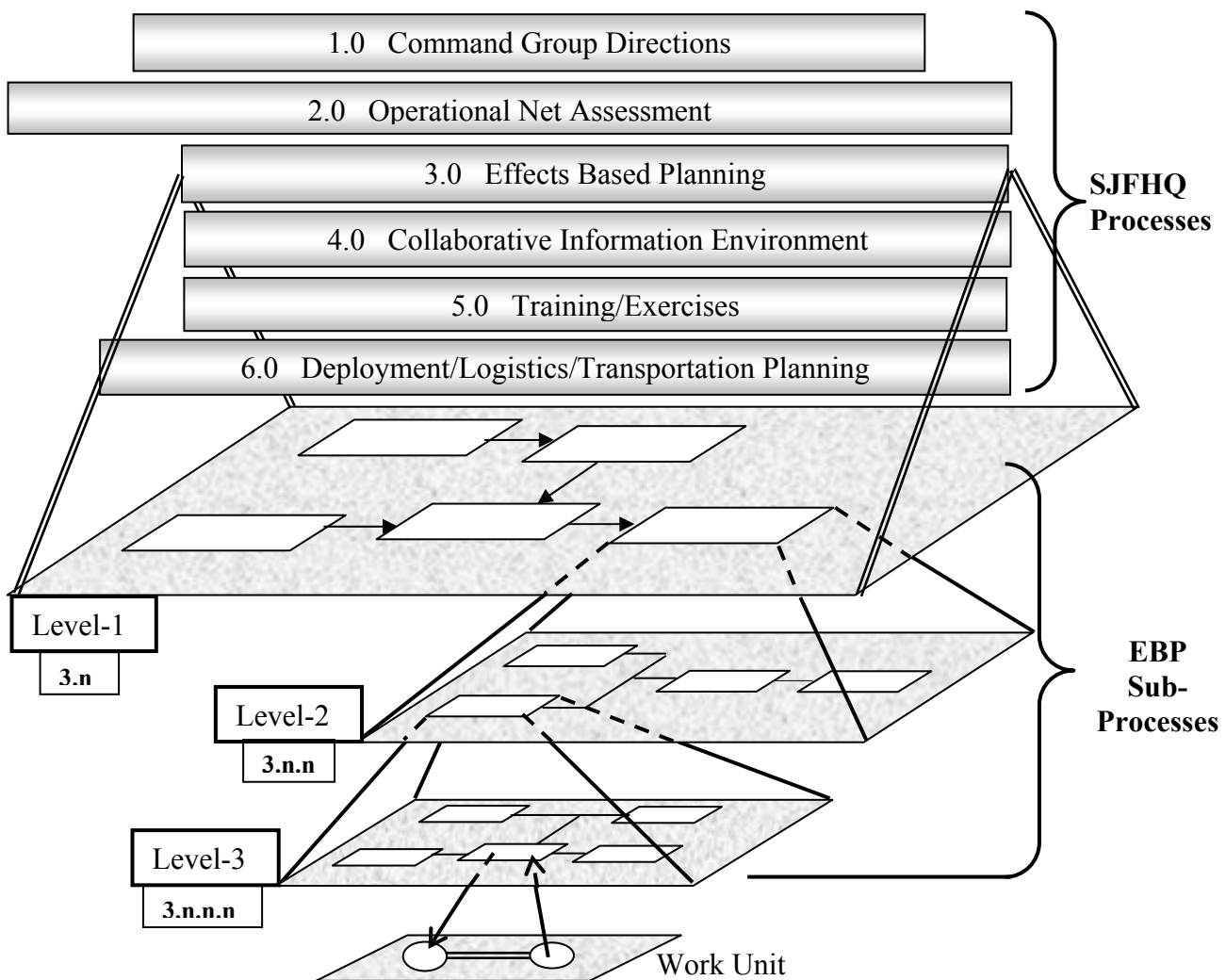

Figure 3. Core, Top-Level Processes and three levels of Sub-Processes.

Figure 3 also shows a Level-3 sub-process sending a task to a work-unit (referred to as boards, centers, cells, and work groups/units). A large number of work-units comprise the SJFHQ, the composition of each depending on the tasks assigned to them. A task can be sent to a work-unit only from a Level-3 sub-process.

To some extent a sense of time is indicated in figure 3 by the length and positions of the process bars. For example, ONA originates farthest to the left because that process is ongoing almost continuously, long before a crisis is declared. Similarly, Logistics and Transportation planning is also ongoing, although it is not as lengthy a process as ONA. Command Group Directions will initiate all other processes.

5.2 Sub-Process Definitions

A table in the SJFHQ Simulation report lists all sub-processes and their numbers. Table 2, below, shows a few rows from the first columns in that table for explanation purposes.

Table 2. SJFHQ Sub-Process Definitions

1st Lvl	2nd Lvl	3rd Lvl	Processes and Sub-Processes
Command Group Directions			
1.1	Assess National Guidance		
	1.1.1.1	Dummy	
1.2	Assess AOR Plans		
	1.2.1.1	Dummy	
1.3	Develop Initial Guidance		
	1.3.1	Assess Transition and Provide Guidance	
	1.3.1.1	Dummy	
	1.3.2	Commander's Intent Development	
	1.3.2.1	Develop Commander's Intent	
	1.3.2.2	Transmit Cdr's Intent for Mission Analysis	

Command Group Directions (1.0) is the core, or basic overall process. Develop Initial Guidance (1.3) is the third first-level sub-process, Commander’s Intent Development (1.3.2) its second second-level sub-process, and Transmit Commander’s Intent for Mission Analysis (1.3.2.2) its second third-level sub-process. This last sub-process is at Level-3, which sends that task directly to a task workgroup.

In reality, tasks can be sent to a task workgroup from any level, but in the simulation tasks can be sent to task workgroups only from the third sub-process level. Thus, when a higher-level process sends a task, it is necessary to put dummy levels in the simulation so that the task is sent from the appropriate level. This is the reason for the “Dummy” entries. They have no effect on simulation results, and are only present so that the controlling database can be set up correctly. Table 3 includes the same rows as shown in Table 2 but shows the last columns from the master table. (The middle columns list personnel assigned to a task and are described in a later section of this report.)

Table 3. Example of Required Input Sources, Task Duration, External Delay, and Task Priority

Inputs From	Duration	Delay	Priority
SECDEF	1		10
RCC	0.5		10
SECDEF, 3.1.1.10	0.2		1
1.3.1.1, 1.1.1.1, 1.2.1.1	0.4		5
1.3.2.1	0.2		1

“Inputs From” refers to those sub-processes from which information must be received before the current sub-processes task assignment can begin. For the initial processes shown here, input

must also be received from outside the SJFHQ organization, from the Secretary of Defense (and/or also the Chairman of the Joint Chiefs of Staff) and the Regional Combatant Commander. Note that input for one of the tasks must be received from one of process 3's sub-processes. Such interconnections are more easily seen in the process maps discussed below.

Duration is the estimated amount of time the task will require with full manning of the task workgroup. In a few instances, information must be requested from an organization outside SJFHQ before a task can be completed. Delay is the amount of time the task will have to idle if such a request must be made.

Priority is used to control the order in which personnel perform tasks, with 1 being the highest and 10 the lowest priority. Several priority 10 tasks can be on a person's desk at the same time and will be worked on in the order they arrive. Higher priority tasks will interrupt lower priority tasks.

5.3 Process Architecture Maps

A process architecture map is required at each sub-level. Figure 4 contains the first-level architecture map. Second- and third-level maps are too large to be included here and are presented in Schacher, et al., 2004. Examples of small sections of the lower-level maps are included in the following sections with explanations.

The first-level map shows the six basic processes and their first-level sub processes. The arrows show the flow of information from one sub-process to those following it in time. This figure does depict a time flow, e.g. from top to bottom. The dashed boxes indicate processes that occur outside this version of the simulation.

The processes are not depicted in numerical order in figure 4 because it is easier to depict the connection arrows using the order shown. Figure 5 shows a portion of the second-level sub-processes. In this figure, the arrows more accurately represent information flow than is seen in the first-level diagram. The level of detail included in this Second-Level map is probably the best for visualizing information flow, but does not identify the tasks that consume and produce information. Those tasks are seen in the third-level map, a portion of which is shown in Figure 5.

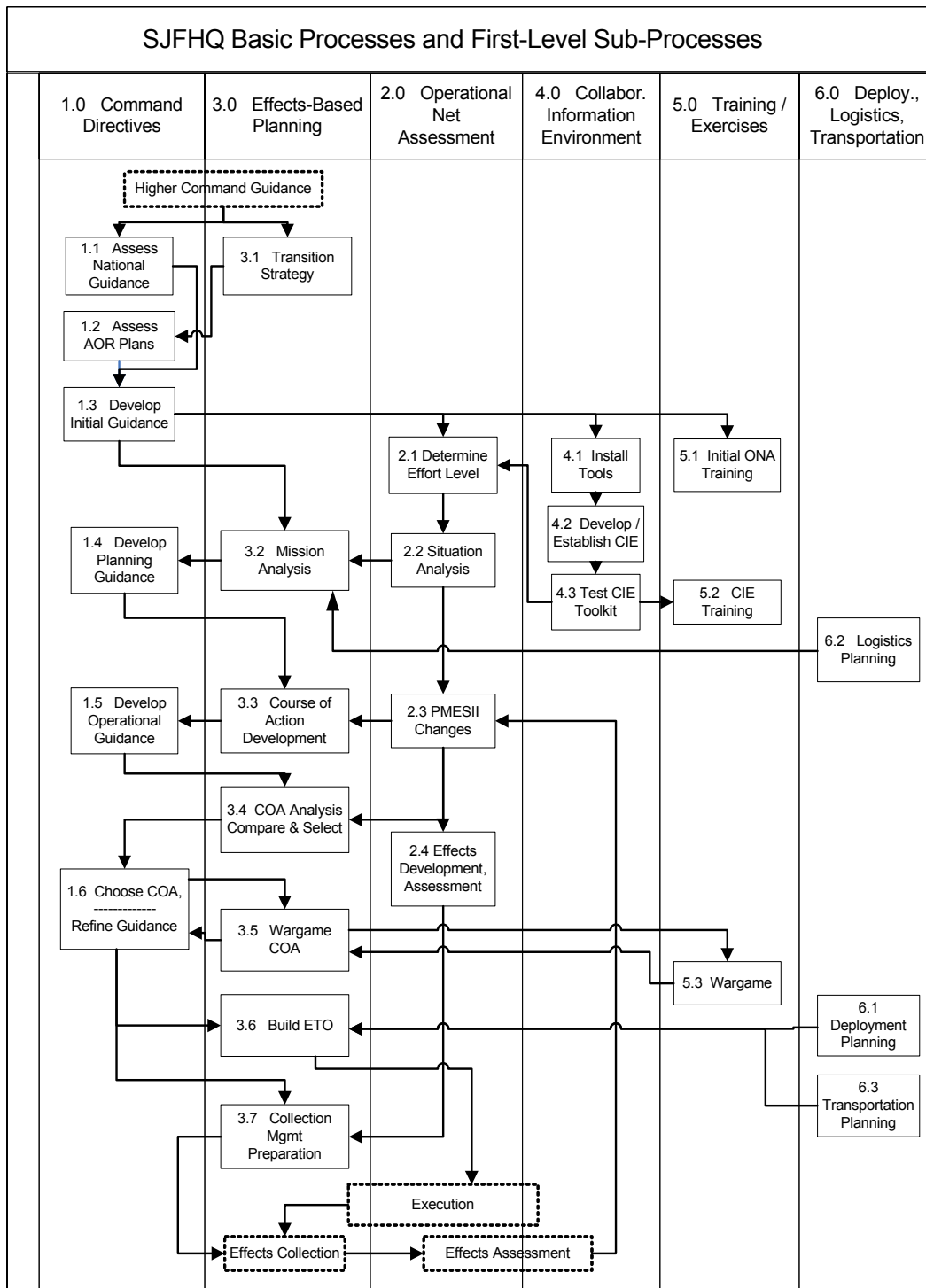

Figure 4. Basic and First-Level Processes and Information Flow.

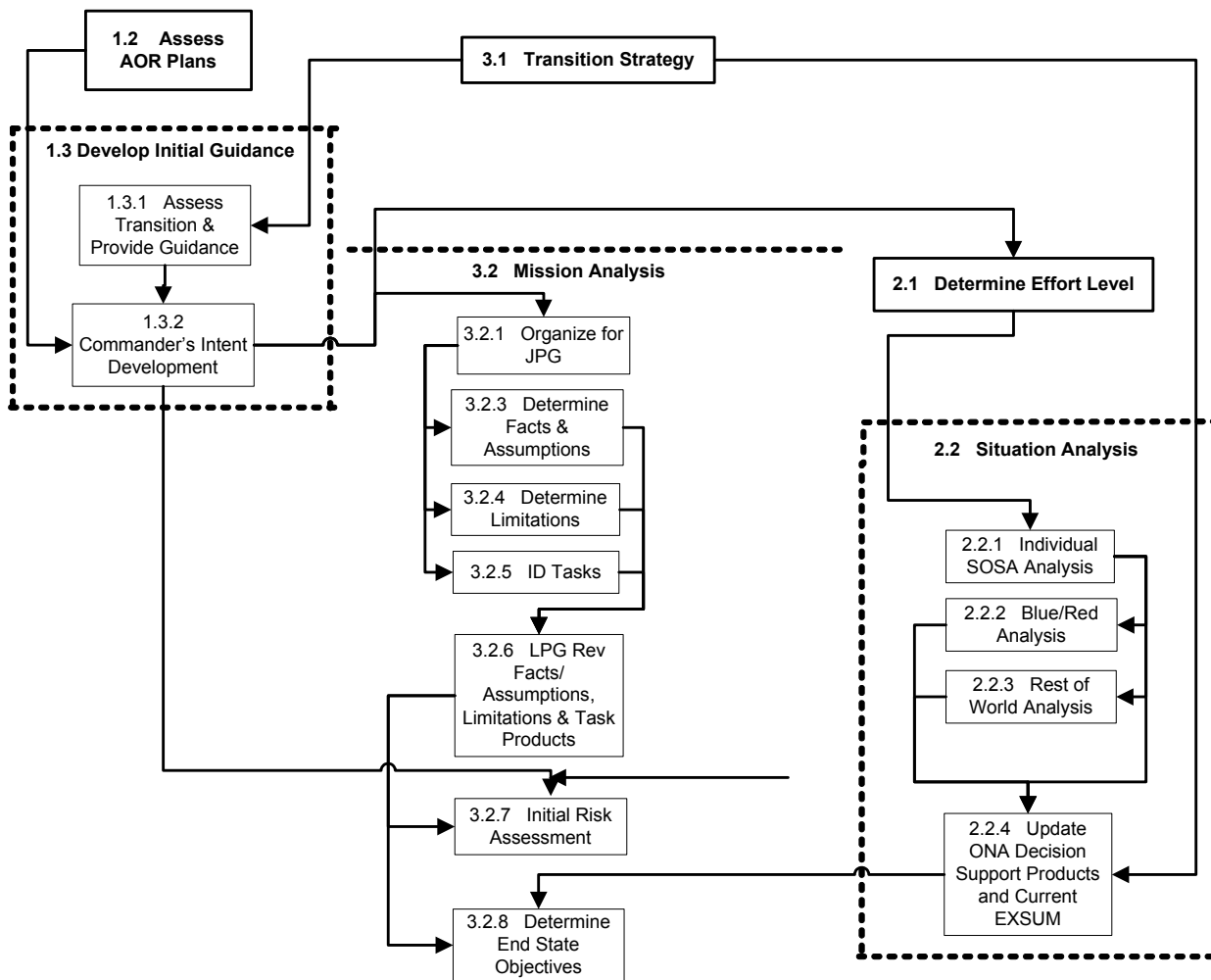

Figure 5. Example of a Portion of the Second-Level Sub-Processes.

Some arrows in Figure 5 are incomplete because they connect to process boxes that are not included in this example. The heavy dashed boxes delineate First-Level sub-processes and show the second-level processes included in each higher-level process.

Figure 6 shows a small portion of the Third-Level sub-process map. This map contains no titles, only sub-process numbers, because titles would take up too much space. (For example, in the second- and third-level maps take up three and five pages, respectively.) Dashed lines are used for some of the information flows to reduce visual confusion. The type of line has no other significance. Sub-process blocks that are in sequence, and for which information flows from one to the next in order of sequence, are placed in direct contact rather than showing an arrow in order to save space.

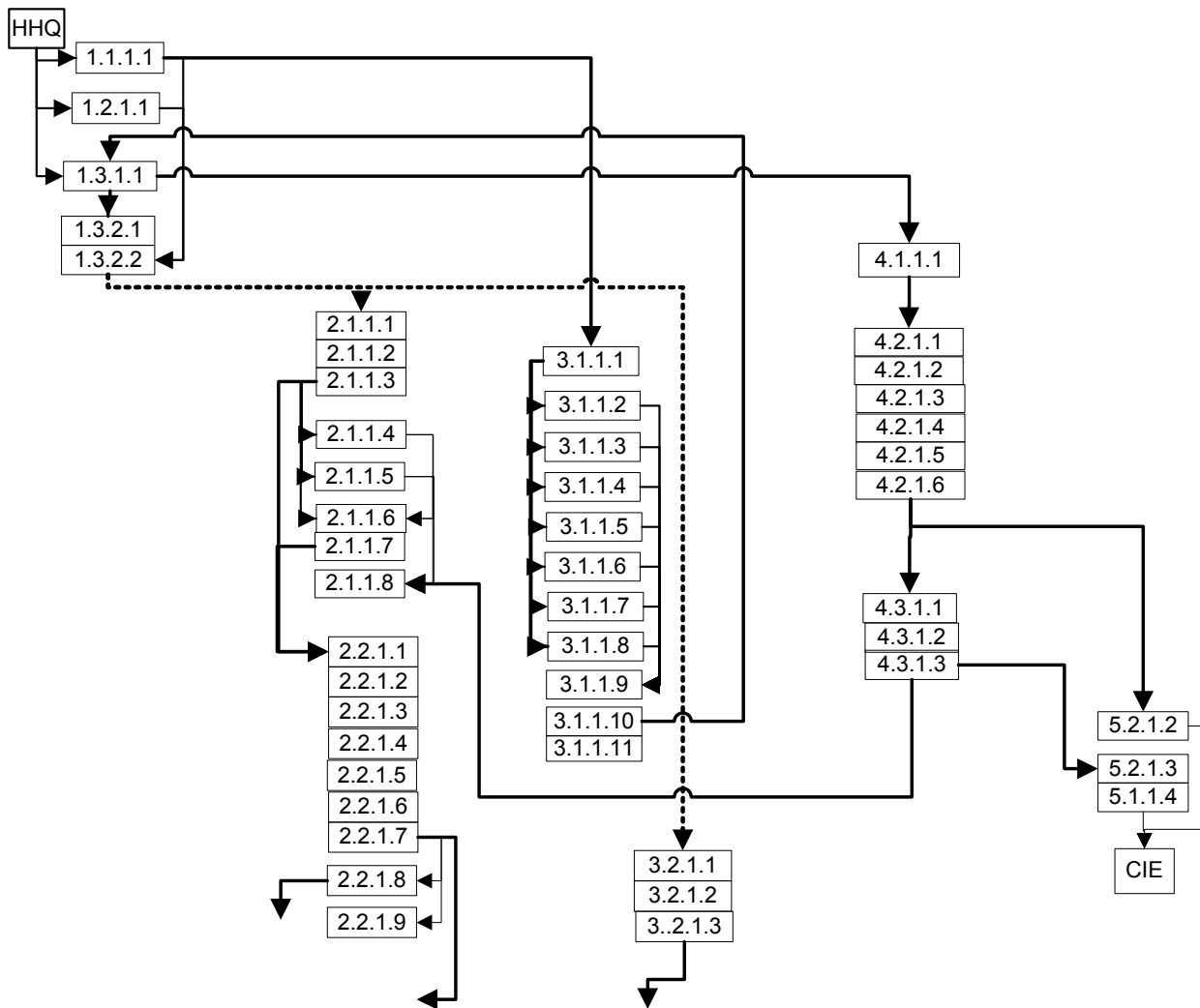

Figure 6. Third-Level Map of Standing Joint Force Headquarters Sub-Processes.

5.3.1 Study Results Parameters: The simulation was set up to obtain time measures for start and end times for all processes and sub-processes and for all individuals working on each task. A large number of utilization and efficiency studies can be accomplished with such output. Definition of the questions for which data is desired is needed at the outset of a simulation run; output tables can then be configured to produce data to answer the specified questions.

One could determine the effect on product quality of having a cutoff time for tasks (such as stopping work on a product to meet a delivery time). In order to produce such data one would change task performance work rules and also produce an information quality measure. Such a situation is realistic, e.g., whether the effects analysis process is complete, or if personnel who perform this task have the information needed to accomplish the task.

5.3.2 Study Conditions and Simulation Configuration: A simulation is configured for a set of conditions: Operational conditions, systems to be used, number of personnel, and their assignments. Changes in conditions can produce changes in either (or both) the simulation architecture or parameters included in the database tables.

5.3.3 Simulation Parameters: The simulation contains several types of parameters: (1) task completion times, (2) personnel work rules, (3) task priority rules, (4) meeting and briefing priorities, and (5) task performance work rules.

6. PERSONNEL TASKING

6.1 Work Assignments

All tasks are “sent” to a group of defined individuals. The individuals are identified by number, as is shown in the following segment of the table from Schacher, et al., 2004.

Table 4. Sample of Work Assignments and Personnel Tasking

2.1.1.1	Assess Intel, Cdrs' Guidance, Geospatial Info	35, 36, 37, 42, 43, 46, 47, 48, 49, 50, 52, 53, 54, 55, 56, 57, 58, 64
2.1.1.2	Compare Situation & Intel with ONA Baseline	50, 51, 52, 53, 54, 55, 56, 57
2.1.1.3	Identify changes in Environment	50, 51, 52, 53, 54, 55, 56, 57

The titles of the numbered individuals are shown in table 5. Table 5 also shows assignments of SJFHQ personnel to the Teams, Groups, and Cells as listed in the reference documents. This information, and SME knowledge, was used to define the personnel assignments shown in the table.

6.2 Assignments to Task Workgroups

Table 5 shows the various organizations and the people who are assigned to them as defined by the reference documents.

Using the database methodology, the simulation runs on a set of tables that specify processes and how they are interconnected. Task assignments are defined in the same table that specifies who works on each task. Table 5 shows major assignments and is too coarse to use for task assignments. A table was developed to use the numbers of the personnel assigned to a workgroup as a string title for that workgroup. This saves a great deal of time when reassigning personnel to tasks. However, it is not an intuitive method for workgroup identification. A Graphical-User-Interface (GUI) that uses named workgroup identifiers, names that would be agreed to by users, remains to be developed.

6.3 Simulation Human Tasking Module

In order to accurately model the multitasking regime of each SJFHQ team member, a unique simulation block construct was developed that warrants some detailed explanation. The modeling constructs for this section are encapsulated in each Person’s h-block, in a sub h-block called “Working On Assignments.” As assignment items are generated by the Tasks layer and sent to individual team members, they are assigned a priority attribute (generally from 1 to 15). In addition, each individual team member has a specific “priority cusp” that is used for prioritizing tasks within an individual’s desktop. A combination of an assignment’s priority value and the team member’s priority cusp leads to the proper routing of assignments within the multitasking constructs. This comparison subsequently determines how an arriving assignment impacts other assignments already being worked on.

Table 5. Personnel Assignments in the SJFHQ Organization.

		Groups and Teams										Boards, Centers, Cells, Working Groups																
		Command Group	Info Superiority Grp	Info Superiority Trm	ONA Section	Intel Section	IO Section	Eff Assessment Cell	Operations Group	Logistics Group	Operations Team	Logistics Group	Planning Team	Effects Working Grp	KM Group	KM Team	JISC	JCMC	JCB (Virtual)	JCB Working Group	JFE Working Group	TSCCT	LCB (virtual)	Blue/Red Cell	JTF-JPG (virtual)	Effects Working Grp	JKM Board	ONA Working Grp
Position																												
1	Director SJFHQ	X																										
2	Chief of Staff	X																										
3	Deputy Chief of Staff	X																										
4	Admini/Supt Coord #1	X																						A				
5	Admin/Suprt Coord #2	X																						A				
6	Plans Chief												L	L									X		L			
7	Deployment Plans Off												X	T									X		X			
8	Ops Law Planner												X	T							X		X					
9	Planner (Aerospace)				X								X	T						X					X			
10	Planner (Army)				X								X	T											X			X
11	Planner (USMC)				X								X	T											X			X
12	Planner (Maritime)				X		X						X	T											X			X
13	Planner (Space-STO)				X								X	T											X			X
14	SOF Planner				X								X	T											X			X
15	Pol/Mil Planner				X								X	T	X						X		X	X	A			X
16	Blue/Red Planner #1				X								X	T	X		A							X	A			X
17	Blue/Red Planner #2				X								X	T	X		A							X	A			X
18	FP Plnr (TBE/WME)				X								X	T							X		X		X			X
19	Operations Chief		A						XL	TL												L		X				
20	Aerosp Ops Off #1				X				X	T											X	X		X				X
21	Aerosp Ops Off #2				X				X	T											X			X				X
22	Land Ops Officer #1				X				X	T											X	X		X				X
23	Land Ops Officer #2				X				X	T											X			X				X
24	SOF Ops Officer #1				X				X	T											X	X		X				X
25	SOF Ops Officer #2				X				X	T											X			X				X
26	Maritime Ops Off #1				X				X	T											X	X		X				X
27	Maritime Ops Off #2				X				X	T											X			X				X
28	Fires/Targeting Off				X				X	T											L	X		A				X
29	Logistics Ops Chief				A					T	S												L					A
30	Transport Ops Off				A					T	X												X	A				A
31	Logs Coordinator										S		T										X					
32	Strat Mobil Plans Off										X		T										X					
33	Sustain Plans Off				X						X		T								X		X					X
34	Personnel Plans Off										X		T										X					
35	Info Superiority Chief	L	L														L	X			X			X	X			
36	Info Superiority Ops Off	X	T														X	X						X				
37	Intelligence Supervisor	X	T		L												X	X										
38	Intelligence Planner				X								T		X									X				
39	ISR Collection Planner				A								A		X													
40	Current Intel Integrator				A	X				T								X										A
41	ISR Operations Officer				A	X				T												X						A
42	ISR Collection Manager				X												L							X				
43	Info Ops Supervisor	X	L	X	X	L			AL				A								X							X
44	Info Ops Planner				A	X	X			A			AL	X								X		A	X	X		X
45	Info Ops Officer				A	X	X			A			A									X						X
46	PSYOP Specialist				A	A	A	X		A			A															A
47	EW Specialist				A			X		A			A															
48	Comp Net Ops Spec				A	A	A	X		A			A		X	L												
49	ONA Supervisor	X			L																							XL
50	ONA Network Analyst				X																	X						X
51	ONA Effects Planner				X			X					T		X				X						X			X
52	SoSA Analyst (Pol)				X										X													X
53	SoSA Analyst (Mil)				X										X										X			X
54	SoSA Anal (Econ)				X										X													X
55	SoSA Anal (Social)				X										X													X
56	SoSA Analyst (Info)				X										X													X
57	SoSA Anal (Infrastr)				X										X													X
58	Eff Assess Super	X						L							X													
59	Eff Assess Planner				X			X					T	XL								X			X			X
60	Knowledge Mgt Chief														L	L											X	
61	Network Mgt Specialist														X	T											X	
62	KM Officer (Plans)														X	T											X	
63	KM Officer (Ops)									T					X	T											X	
64	KM Off (Info Superior)				X										X	T	X										X	X
65	Jt Network Cntrl Off														X	T											X	

6.3 Simulation Human Tasking Module

In order to accurately model the multitasking regime of each SJFHQ team member, a unique simulation block construct was developed that warrants some detailed explanation. The modeling constructs for this section are encapsulated in each Person’s h-block, in a sub h-block called “Working On Assignments.”

As assignment items are generated by the Tasks layer and sent to individual team members, they are assigned a priority attribute (generally from 1 to 15). In addition, each individual team member has a specific “priority cusp” that is used for prioritizing tasks within an individual’s desktop. A combination of an assignment’s priority value and the team member’s priority cusp leads to the proper routing of assignments within the multitasking constructs. This comparison subsequently determines how an arriving assignment impacts other assignments already being worked on.

For multitasking purposes, an arriving assignment is given one of three classifications: (1) Normal Assignment, (2) Standard Meeting, or (3) Priority Meeting or Assignment. Within the Priority sub h-block of Working On Assignments, an assignment’s classification is determined by comparing the priority attribute with the priority cusp. If the attribute value has a higher priority (lower value) than the cusp, this is a Priority Meeting or Assignment. If it has a priority equal or lower than the cusp (higher value) than it is a Normal Assignment.

A further comparison is then made to determine if this is a Standard Meeting. It is important to note that for this iteration of the SJFHQ simulation a convention was adapted for all team members to have a cusp of 7. A value of 8 was then adapted for all assignments that were to be classified as a Standard Meeting. This priority-to-cusp construct is anticipated to be more fully leveraged in later model versions.

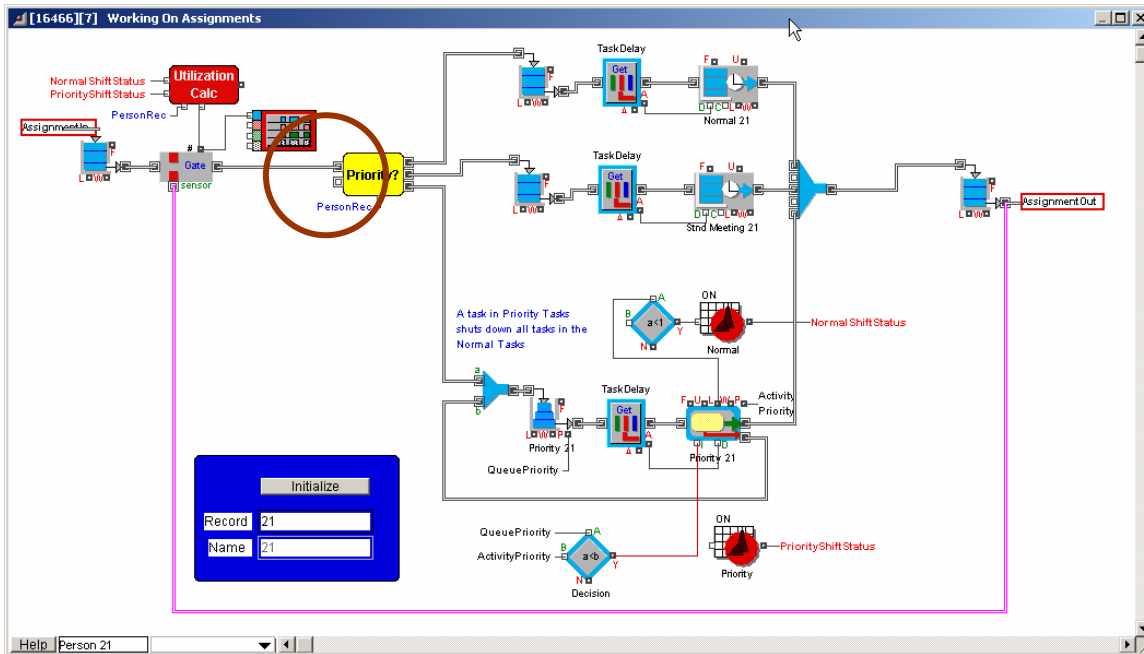

Figure 6. Model Constructs, Working On Assignments Sub H-Block (Person H-Block).

6.3.1 Normal Assignments: Normal assignments are considered multi-tasking equals for completion by the team member. A standard EXTEND Activity, Multiple block is utilized with the “Simulate multitasking activity” option set to On. The related Help section for this block provides the following description for how multitasking delays are handled:

When selected, the processing time of each item will be dynamically changed based on the number of items in the Activity. This will simulate the behavior of a single, shared resource among all of the items in the activity. If there are two items in the activity, the processing for each item will be twice as long as the dialog indicates, if there are three items the processing will be three times as long and so on. This can be used to easily simulate a single worker that has many tasks to perform, but can only do one at a time”

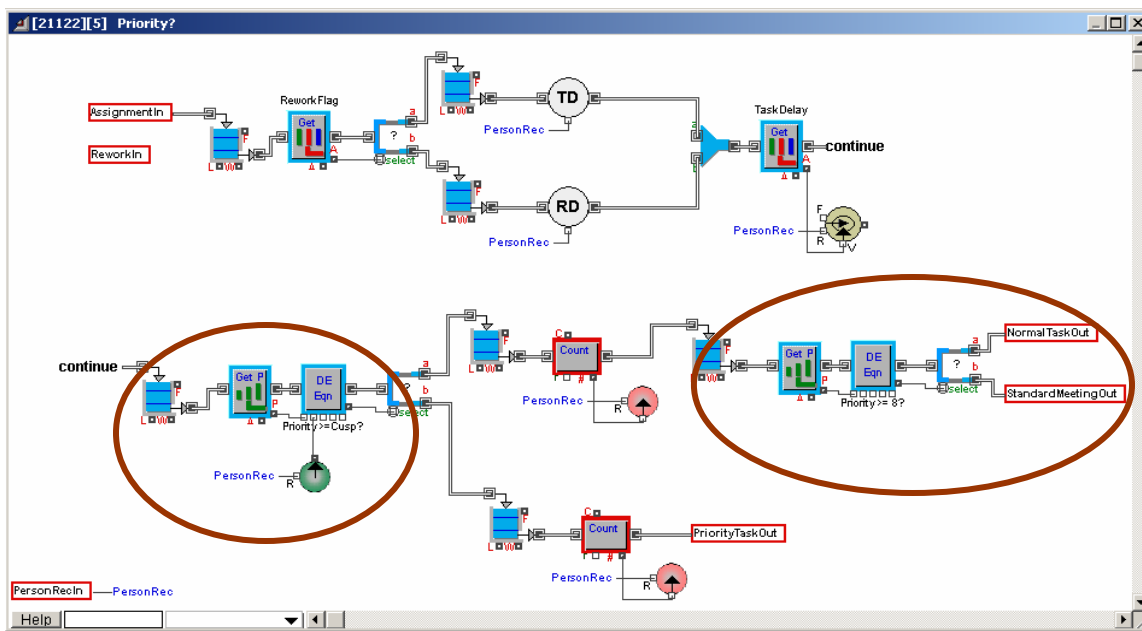

Figure 7. Model Constructs, Priority Sub H-Block (Working On Assignments).

6.3.2 Standard Meetings: Standard Meeting assignments are time-specific assignments that an individual would typically participate in from their desk (such as a on-line collaboration). Because of this decentralized involvement, Normal multitasking desktop activity can (and typically does) continue. From a model construct point of view, the Standard Meeting assignments are routed to a separate EXTEND Activity, Multiple block, but in this case the multitasking option is not selected so that involvements start and end as scheduled. Delay times in the Normal Assignments activity block continue to progress in parallel with Standard Meeting Assignments.

6.3.3 Priority Meetings or Assignments: Priority Meetings and Assignments are handled in a third path of modeling constructs. If an assignment enters this area, all activities in the Normal and Standard Meetings area are set aside (stop processing), and the team member is assumed to be completely focused on the Priority assignment until completion.

The shutdown of the Normal and Standard Meeting activity is accomplished as a part of the daily Shift blocks. If an item enters the Priority activity block, the Shift block receives a value greater than zero from the activity length connector and interprets this as a signal to shutdown. The

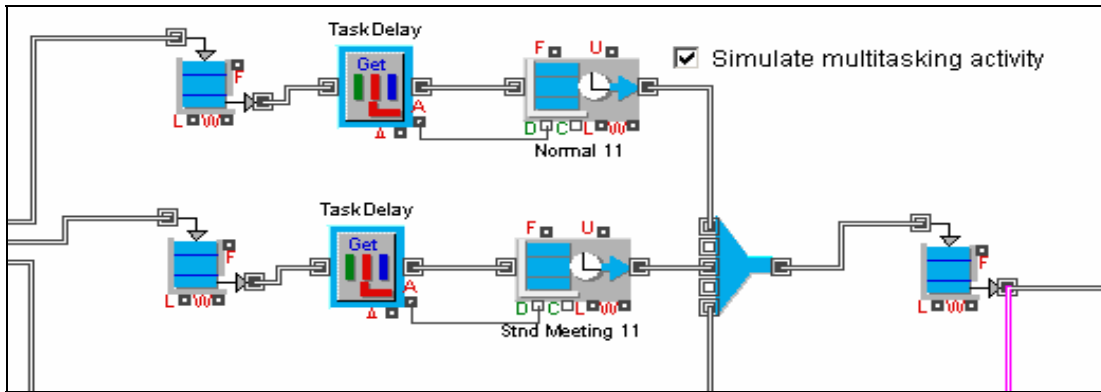

Figure 8. Normal Assignments (top path) and Standard Meeting (bottom path).

priority construct can also accommodate the possibility of a team member having more than one priority assignment on their desk at a time. If an individual is currently working on a priority assignment when another arrives, a comparison is made to the priority attribute values. The assignment with the highest priority (lower value) will be focused on first, with the arriving assignment able to “pre-empt” the current task if necessary. Assignments with equal priority values are handled as FIFO.

7. Results

Simulation results indicate there are large differences in individual workload levels. The percentage of time different personnel devoted to SJFHQ tasks ranged from 94% for the Political/Military Planner to 55% for the Aerospace Planner. While these numbers represent approximations, they do indicate that adjustments in manning, cross-training, or utilization may be needed. The simulation easily reveals the results of personnel multi-tasking and associated work rules. Current work rules assume that all individuals involved with a task work the full duration of time assigned to the task before it can be completed. Modifying this rule will change simulation performance. This also translates into work rules needed to optimize SJFHQ performance during an operation.

The simulation takes approximately three seconds to run through one full cycle of processes. This simulates 260 hours of operational work time and 6000 individual task assignments. The database methodology is highly efficient in that it allows one to use a set of rules to drive the model architecture and simulation parameters. Modification to replicate different real instantiations of SJFHQ utilization and people tasking should be easy to accomplish, including what-if studies.

8. Conclusions

The lack of any systems engineering methodology applicable to perform trade studies for complex information systems has been a deficiency in view of the current focus on the power of information. There is an increasing need for the application of systems engineering principles to the analysis and design of complex, expensive, and performance-critical information systems (Osmundson, 2004). Until recently, system solutions for complex information systems have usually been developed without extensive trade studies and without a solid understanding of system sensitivities to design factors and system input variations.

References

- Osmundson, J. S., Gottfried, R., Kum, C. Y., Boon, L. H., Lian, L. W., Patrick, P. S. W., and Thye, T. C. (2004). Process Modeling: A Systems Engineering Tool for Analyzing Complex Systems. *Systems Engineering*, Vol. 7, No. 4, 2004.
- Osmundson, J. S. (2002). A Systems Engineering Methodology for Information Systems. *Systems Engineering*, Vol. 3, No. 2, 2000.
- Schacher, G., Dailey, J., Looney, J., Saylor, S., Jensen, J. J., Osmundson, J. S., Hutchins, S. G., and Gallup, S. P. (2004). SJFHQ Simulation. Naval Postgraduate School Technical Report, NPS-IS-04-001, Monterey, CA. Prepared for SJFHQ Program Office, Joint Forces Command.
- U.S. Joint Forces Command. (2002). Standing Joint force Headquarters – Fact Sheet. 28 February 2002.
- U.S. Joint Forces Command. (2003). Standing Joint Force Headquarters, Concept of Employment, June 03, Suffolk, VA.
- U.S. Joint Forces Command. (2003). Standing Joint Force Headquarters, Standard Operating Procedures, October 03, Suffolk, VA.
- <http://www.imaginethatinc.com>



USJFCOM

United States Joint Forces Command



Modeling and Simulation Support for the Standing Joint Force Headquarters Concept

Susan G. Hutchins,¹ Gordon E. Schacher,¹ James Dailey,²

John P. Looney,¹ Steven E. Saylor,² Jack J. Jensen,¹

John S. Osmundson,¹ and Shelley P. Gallup¹

¹Naval Postgraduate School, Monterey, CA

²The Boeing Company Seattle, WA



Standing Joint Force Headquarters Background

- Provides a standing element that focuses on a Commander in Chief's (CINC) operational trouble spots
 - Knowledge-centric, cross-functional organization takes advantage of knowledge and information flow
 - Functions at the operational level of national defense as the joint C2 element to support a rapid decisive operation
 - Provides information and collaboration support for Regional Combatant Commanders and/ or Joint Task Forces
- Provide each regional CINC an informed and in-place C2 capability
 - 65 people integrate directly w/ any regional command structure
 - SMEs for Effects-Based Planning and Operations processes
 - Reduce the *ad hoc* nature of standing up today's JTF Hqtrs
 - Provide increased stability as a result of the deep situational understanding developed prior to SJFHQ employment
 - SJFHQ will give the CINCs an advantage of time, perhaps the most critical resource

Groups and Teams

Boards, Centers, Cells, Working Groups

T=Team Member
 X=Assigned
 A=Augment/Support
 C=Coordinates
 L=Assigned Lead
 S=Secondary Lead

Position	Command Group	Info Superiority Grp	Info Superiority Tm	ONA Section	Intel Section	IO Section	Eff Assessment Cell	Operations Group	Logistics Group	Operations Team	Logistics Group	Planning Team	Effects Working Grp	KM Group	KM Team	JISC	JCMC	JCB (Virtual)	JCB Working Group	JFE Working Group	TSCT	LCB (virtual)	Blue/Red Cell	JTF-JPG (virtual)	Effects Working Grp	JKM Board	ONA Working Grp
1 Director SJFHQ	X																										
2 Chief of Staff	X																										
3 Deputy Chief of Staff	X																										
4 Admini/Supt Coord #1	X																					A					
5 Admin/Suprt Coord #2	X																					A					
6 Plans Chief										L	L											X	L				
7 Deployment Plans Off										X	T											X	X				
8 Ops Law Planner										X	T								X			X					
9 Planner (Aerospace)				X						X	T												X			X	
10 Planner (Army)				X						X	T												X			X	
11 Planner (USMC)				X						X	T												X			X	
12 Planner (Maritime)				X		X				X	T												X			X	
13 Planner (Space-STO)				X						X	T															X	
14 SOF Planner				X						X	T												X			X	
15 Pol/Mil Planner				X						X	T	X								X		X	X	A		X	
16 Blue/Red Planner #1				X						X	T	X		A								X	A			X	
17 Blue/Red Planner #2				X						X	T	X		A								X	A			X	
18 FP Plnr (TBE/WME)				X						X	T										X	X	X			X	
19 Operations Chief		A					XL	TL													L		X			X	
20 Aerosp Ops Off #1				X			X	T												X	X		X			X	
21 Aerosp Ops Off #2				X			X	T												X			X			X	
22 Land Ops Officer #1				X			X	T												X	X		X			X	
23 Land Ops Officer #2				X			X	T												X			X			X	
24 SOF Ops Officer #1				X			X	T												X	X		X			X	
25 SOF Ops Officer #2				X			X	T												X			X			X	
26 Maritime Ops Off #1				X			X	T												X	X		X			X	
27 Maritime Ops Off #2				X			X	T												X			X			X	
28 Fires/Targeting Off				X			X	T												L	X		A			X	
29 Logistics Ops Chief				A					T	S												L				A	
30 Transport Ops Off				A					T	X												X	A			A	



Goal for Modeling and Simulation

- **Gain insight into personnel issues**
 - Number and types of people needed to perform specific functions
 - Where bottlenecks occur in conducting the EBP processes
 - Impact of workload on time to complete overall EBP process
 - Use results to
 - Improve assignment of tasks to personnel
 - Identify critical nodes where delay in processes will cause disruptions in SJFHQ performance
- **SJFHQ responsibilities identified and tracked**
 - Scheduled meetings
 - Information production
 - Command and team decisions
 - Information assessment
- **Many involve sub-processes, e.g., producing specific information**
 - Broken down – individual tasks
 - Identify groups of people that perform tasks
- **Tracked personnel activities, work on desktop, how performing tasks is affected by multi-tasking**



USJFCOM

United States Joint Forces Command



Simulation Development Tasks

- 1. Determine all SJFHQ processes**
- 2. Decompose processes into three levels of sub-processes, down to the individual task level**
- 3. Develop an SJFHQ operational architecture**
- 4. Vet the architecture with J89**
- 5. Identify tasks that are performed to accomplish these processes**
- 6. Determine task sequencing, interdependences, and information flow**
- 7. Identify the individuals, by title, who work on these tasks**
- 8. Define task workgroups (all processes decomposed to the task level)**
- 9. Develop methodology and accompanying tables that map people, task workgroups, and processes to provide the database foundation for the simulation**
- 10. Develop a multi-tasking module that represents human work performance**
- 11. Create the baseline SJFHQ simulation**
- 12. Perform rigorous tests of the simulation to insure proper operation (verification)**
- 13. Report the results of simulation runs to illustrate use of the methodology**



USJFCOM

United States Joint Forces Command

Determine SJFHQ Processes



➤ SJFHQ sub-organizations:

- Command Group
- Information Superiority Group
- Operations Group
- Logistics Group
- Planning Group
- Knowledge Management Team

➤ Boards, Centers, Cells, and Working Groups:

- Joint Information Superiority Cell
- Joint Collection Management Cell
- Joint Coordination Board (JCB)
- JCB Working Group
- Joint Fires Working Group
- Time-Sensitive Targets Cell
- Logistics Coordination Board
- Blue/Red Cell
- Joint Planning Group (at JTF level)
- Joint Knowledge Management Brd



Decompose processes into three levels of sub-processes

SJFHQ Top-Level Processes and Number of Sub-Processes for each Sub-Level within the Model

<u>Process</u>	<u>Sub-Processes</u>		
	<u>Level-1</u>	<u>Level-2</u>	<u>Level-3</u>
Command Directives	6	4	19
Effects-Based Planning	4	15	76
Operational Net Assessment	7	35	235
Collaborative Info Environment	3	3	10
Training Exercises	3	3	15
Deployment/Logs/Transport	3	3	22
Total # task-level sub-processes			<hr/> 377



Develop a SJFHQ Operational Architecture

- **Architecture required for process simulation uses components from the Department of Defense Architecture Framework**
 - **Decomposition EBP process captured in process maps**
 - **Provide way to visualize information flow and process interrelationships**
 - **Process blocks laid out on a visual template and connections made between them, when maps are used**
 - **Database method reported here, tables were used**
 - **Developing the maps was a necessary step to ensure that information flow is correct, logical, and contains neither sinks (processes that have no output) nor infinite loops**



Simulation Methodology

- **EXTEND simulation software, discrete event application**
 - **Rapidly develop wide range of process models**
 - **Boeing's Phantom Works group expertise using EXTEND**
 - **Developed simulation analysis tools for wide variety military/commercial system architectures**
- **Models structured by connecting library block components**
 - **Logically describe process/system being modeled**
- **Library of validated base blocks**
 - **>95% SJFHQ model developed with standard EXTEND components**
 - **Augmented with custom Boeing/SJFHQ block components**
 - **Model unique characteristics of SJFHQ scenario**
 - **Stored and delivered in EXTEND library file – installed before launching model file**
- **Leverages EXTEND's strong hierarchical capabilities**
 - **Powerful ability to structure scenario input data within its own internal relational database**



Top-level view of the EXTEND Standing Joint Force Headquarters Model

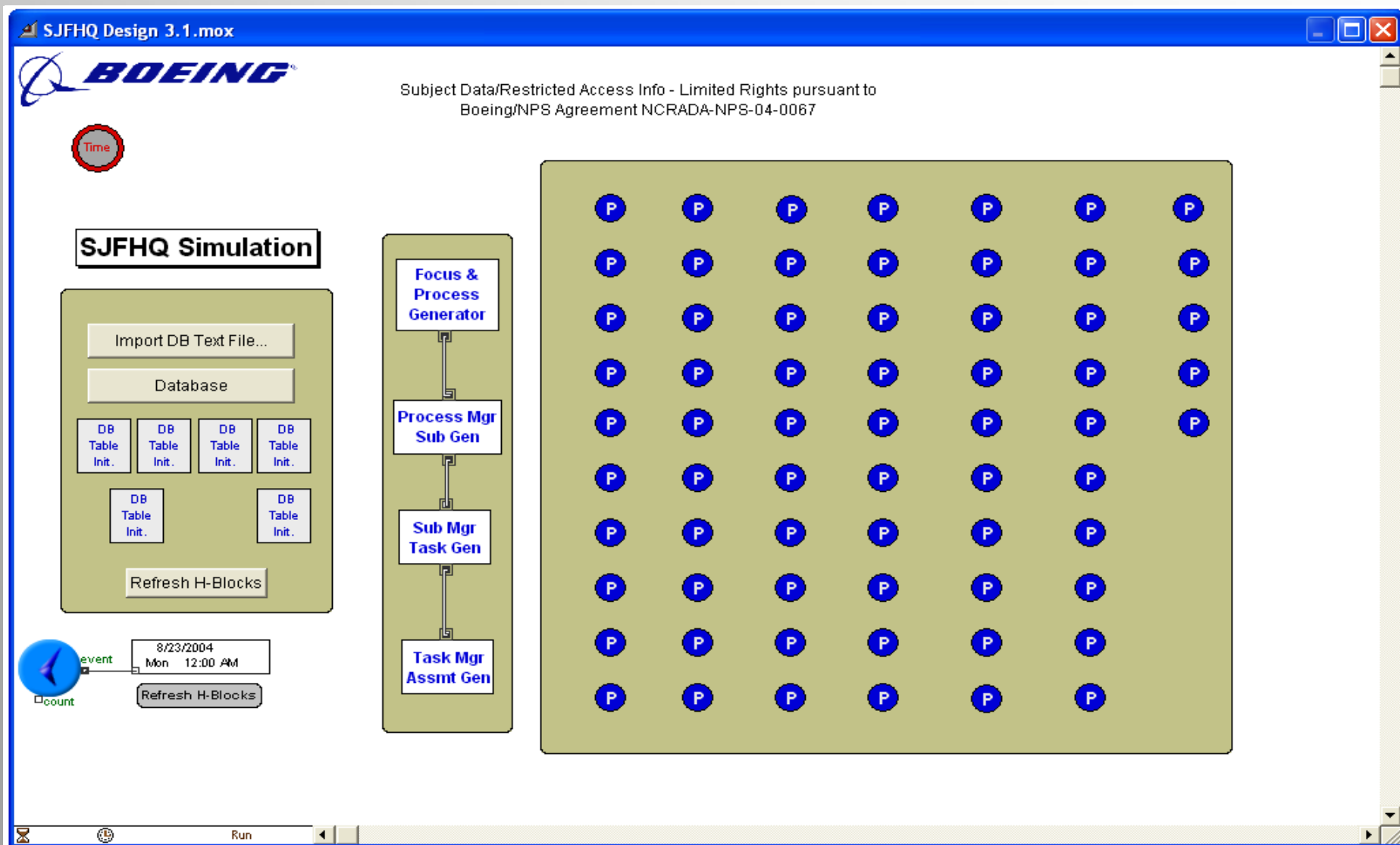



Model Constructs, Person H-Block

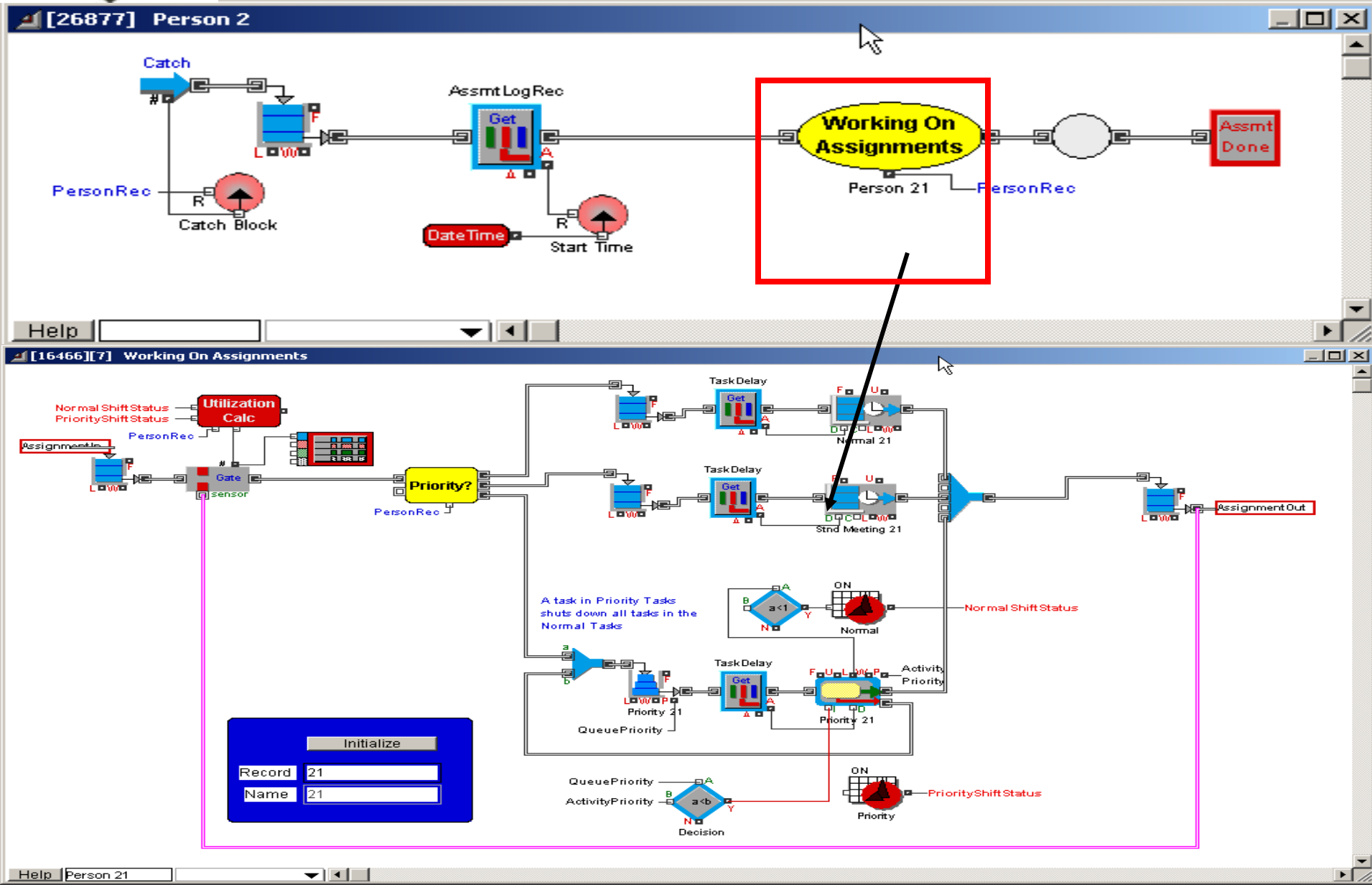



Core, Top-Level Processes and three levels of Sub-Processes

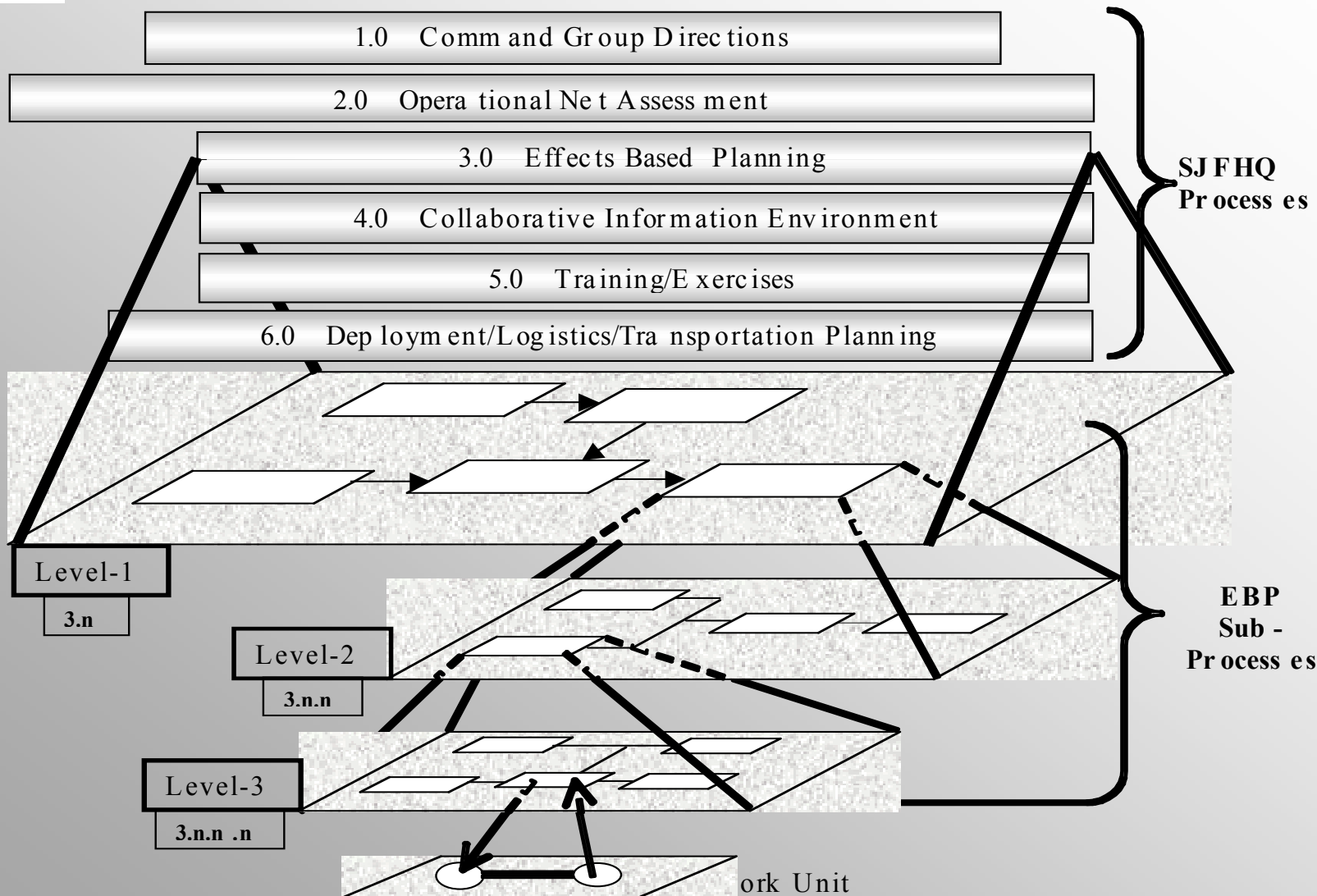



SJFHQ Sub-Process Definitions

1st	2nd	3rd	Level	Processes and Sub-Processes
1.0				Command Group Directives
1.1				Assess National Guidance
		1.1.1.1		Dummy
1.2				Assess AOR Plans
		1.2.1.1		Dummy
1.3				Develop Initial Guidance
		1.3.1		Assess Transition and Provide Guidance
		1.3.1.1		Dummy
		1.3.2		Commander's Intent Development
		1.3.2.1		Develop Commander's Intent
		1.3.2.2		Transmit Cdr's Intent for Mission Analysis



Example of Required Input Sources, Task Duration, External Delay, and Task Priority

Inputs From	Duration	Delay	Priority
SECDEF	1		10
RCC	0.5		10
SECDEF, 3.1.1.10 1.3.1.1,	0.2		1
1.1.1.1, 1.2.1.1	0.4		5
1.3.2.1	0.2		1



Example of a Portion of the Second-Level Sub-Processes

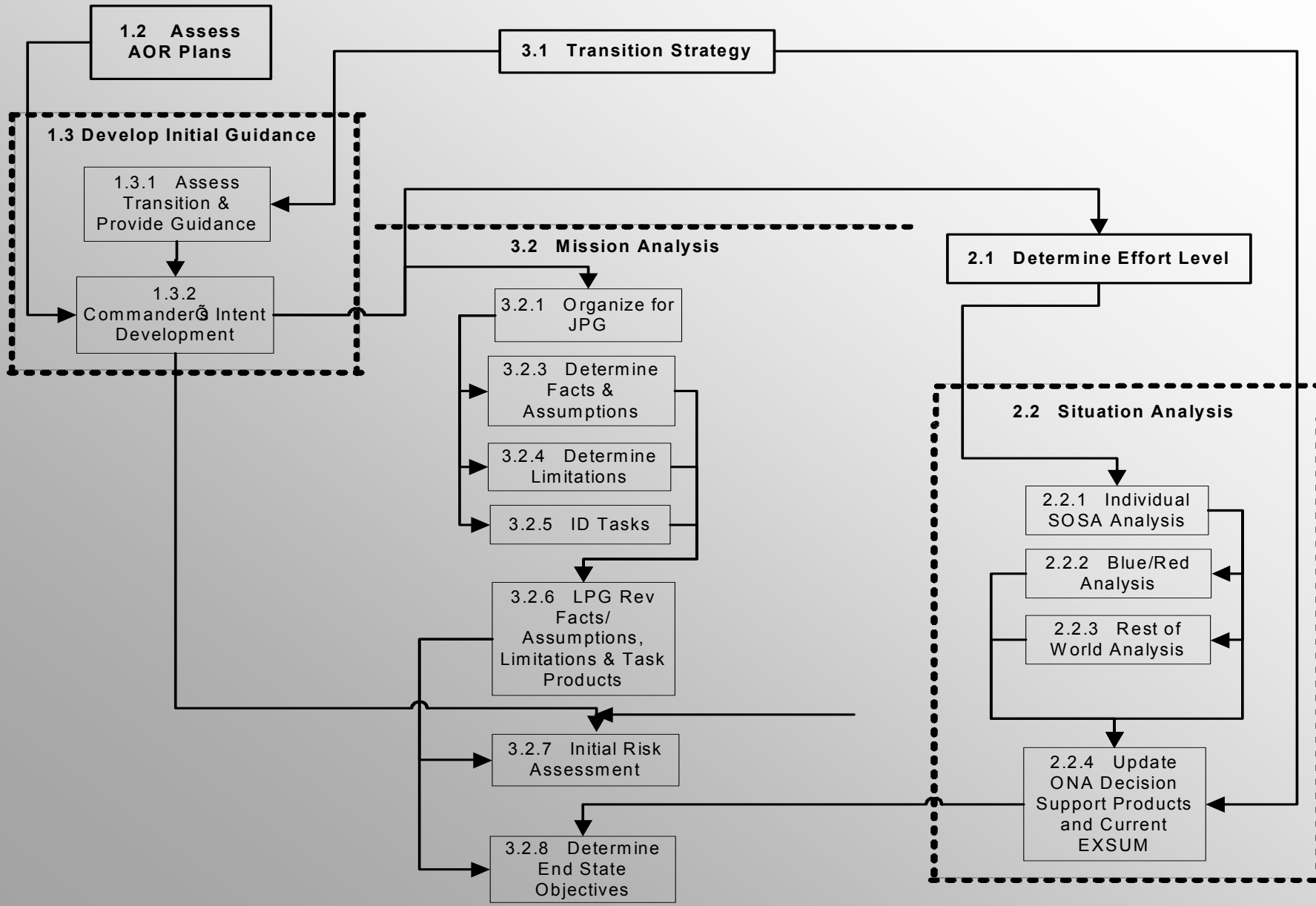



Third-Level Map of Standing Joint Force Headquarters Sub-Processes

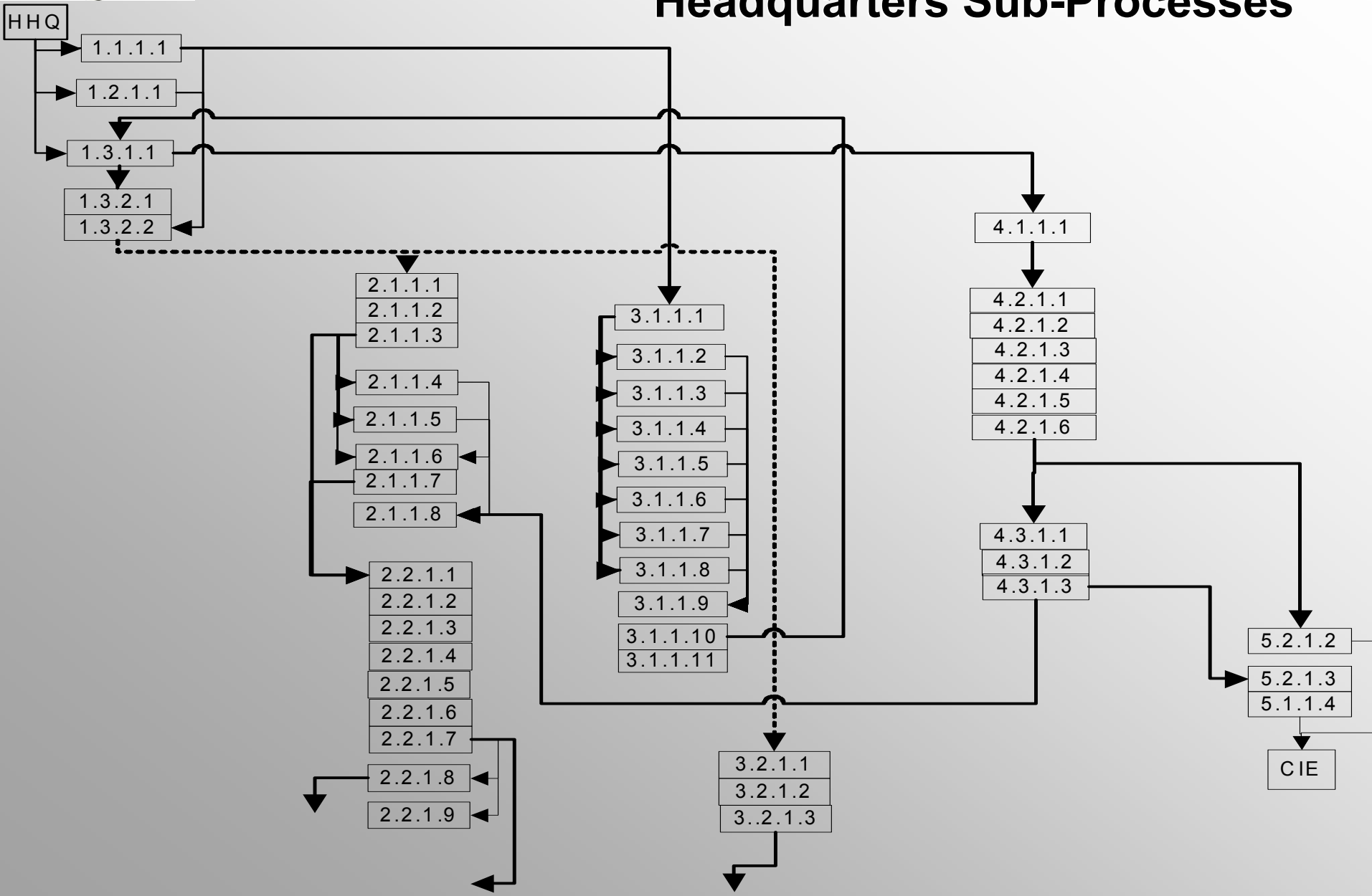



PERSONNEL TASKING

Sample of Work Assignments

2.1.1.1	Assess Intel, Cdr's Guidance, Geospatial Info	35, 36, 37, 42, 43, 46, 47, 48, 49,...55, 56, 57, 58, 64
2.1.1.2	Compare Situation & Intel with ONA Baseline	50, 51, 52, 53, 54, 55, 56, 57
2.1.1.3	Identify Changes in Environment	50, 51, 52, 53,54, 55, 56, 57



Normal Assignments (top path) and Standard Meeting (bottom path)

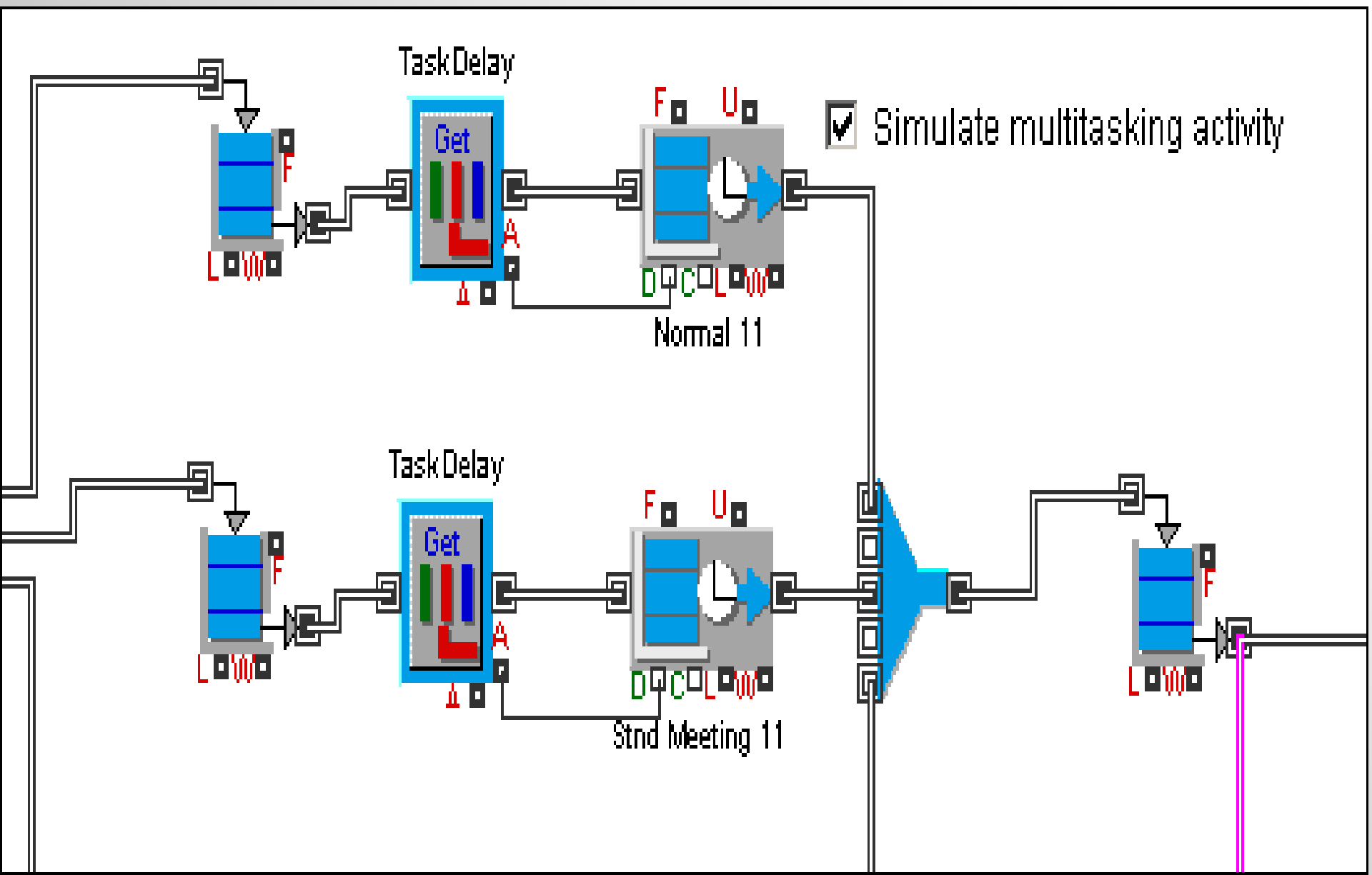



Results and Conclusions

- **M&S provides an efficient and cost effective means to obtain data to provide inputs to answer key questions of interest to concept developers**
- **Information can be used to examine details regarding SJFHQ processes and task performance and make decisions so that initial use of these units can be as efficient as possible**
- **Total Simulation run time – ~3 seconds**
 - **260 Total work hours**
- **Large variations in personnel use**
 - **Pol/Mil Planner 246 tasks worked 94% of time**
 - **Aerospace Ops Off'r #1 66 29%**
 - **Aerospace Ops Off'r #2 14 5%**
- **Possible solutions to workload inequities**
 - **Modify number of personnel types assigned**
 - **Cross train so people can perform a wider range of tasks**