

REPORT DOCUMENTATION PAGEForm Approved
OMB No. 0704-0188

Public reporting burden for this collection of information is estimated to average 1 hour per response, including the time for reviewing instructions, searching existing data sources, gathering and maintaining the data needed, and completing and reviewing this collection of information. Send comments regarding this burden estimate or any other aspect of this collection of information, including suggestions for reducing this burden to Department of Defense, Washington Headquarters Services, Directorate for Information Operations and Reports (0704-0188), 1215 Jefferson Davis Highway, Suite 1204, Arlington, VA 22202-4302. Respondents should be aware that notwithstanding any other provision of law, no person shall be subject to any penalty for failing to comply with a collection of information if it does not display a currently valid OMB control number. **PLEASE DO NOT RETURN YOUR FORM TO THE ABOVE ADDRESS.**

1. REPORT DATE (DD-MM-YYYY) 10-09-2006		2. REPORT TYPE Conference Paper POSTPRINT		3. DATES COVERED (From - To) 2001 - 2006	
4. TITLE AND SUBTITLE Fiber Laser Component Testing for Space Qualification Protocol Development				5a. CONTRACT NUMBER F29601-01-D-0078	
				5b. GRANT NUMBER	
				5c. PROGRAM ELEMENT NUMBER	
6. AUTHOR(S) 1. Suzanne Falvey, Marisol Buelow, Burke Nelson, Yuji Starcher 2. Lee Thienel, Charley Rhodes 3. Thomas Drape, Caleb Westfall				5d. PROJECT NUMBER	
				5e. TASK NUMBER	
				5f. WORK UNIT NUMBER	
7. PERFORMING ORGANIZATION NAME(S) AND ADDRESS(ES) 1. Northrop Grumman 2600 Yale Blvd. SE, Albuquerque, NM 87106-4217 2. Jackson and Tull Space and Aeronautics Technology Division 1601 Randolph Road SE, Suite 100N Albuquerque, NM 87106-4360				8. PERFORMING ORGANIZATION REPORT NUMBER	
9. SPONSORING / MONITORING AGENCY NAME(S) AND ADDRESS(ES) 3. Air Force Research Laboratory Space Vehicles Directorate 3550 Aberdeen Ave SE Kirtland AFB, NM 87117-5776				10. SPONSOR/MONITOR'S ACRONYM(S) AFRL/VSSV	
				11. SPONSOR/MONITOR'S REPORT NUMBER(S) AFRL-VS-PS-TP-2007-1001	
12. DISTRIBUTION / AVAILABILITY STATEMENT Approved for public release; distribution is unlimited. (Clearance #VS06-0546)					
13. SUPPLEMENTARY NOTES Published in the Proceedings of the 2006 AMOS Technical Conference, 10-14 Sep 06, Maui, HI, pp. 298-310. Government Purpose Rights					
14. ABSTRACT A test protocol for the space qualifying of Ytterbium (Yb)-doped diode-pumped fiber laser (DPFL) components was developed as a deliverable on the Bright Light program. A literature search was performed and summarized in a conference paper that formed the building blocks for the development of the test protocol. The test protocol was developed from the experience of the Bright Light team, the information in the literature search, and the results of a study of the Telcordia standards. Based on this protocol developed, test procedures and acceptance criteria for a series of vibration, thermal-vacuum, and radiation exposure tests were developed for selected components. Northrop Grumman in Albuquerque led the effort in vibration and thermal (no vacuum) testing of these components at the Aerospace Engineering Facility (AEF) on Kirtland Air Force Base (KAFB), NM. The results of these tests have been evaluated. Aerospace Corporation led the effort in destructive physical analysis and radiation testing of these components at their facility in El Segundo, CA. This paper discusses the vibration and thermal testing that was executed to validate the test protocol. The lessons learned will aid in future assessments and definition of space qualification protocols.					
15. SUBJECT TERMS Ytterbium, Yb, DPFL, Telcordia, Thermal-Vacuum, Vibration, Radiation Testing, Fiber Laser, Bright Light					
16. SECURITY CLASSIFICATION OF:			17. LIMITATION OF ABSTRACT Unlimited	18. NUMBER OF PAGES 14	19a. NAME OF RESPONSIBLE PERSON Major Thomas Drape
a. REPORT Unclassified	b. ABSTRACT Unclassified	c. THIS PAGE Unclassified			19b. TELEPHONE NUMBER (include area code) 505-853-3247

Fiber Laser Component Testing for Space Qualification Protocol Development

Suzanne Falvey, Marisol Buelow, Dr. Burke Nelson, Yuji Starcher
Northrop Grumman, 2600 Yale Blvd. SE, Albuquerque, NM 87106-4217

Lee Thienel*, Dr. Charley Rhodes
*Jackson and Tull, Space and Aeronautics Technology Division,
 1601 Randolph Road, SE, Suite 100N, Albuquerque, NM 87106-4360*

Major Thomas Drape, Lieutenant Caleb Westfall**
*Air Force Research Laboratory, Air Force Materiel Command,
 3550 Aberdeen Avenue SE, KAFB, NM 87117-5776*

1. INTRODUCTION

A test protocol for the space qualifying of Ytterbium (Yb)-doped diode-pumped fiber laser (DPFL) components was developed as a deliverable on the Bright Light program. A literature search was performed and summarized in a conference paper that formed the building blocks for the development of the test protocol.¹ The test protocol was developed from the experience of the Bright Light team, the information in the literature search, and the results of a study of the Telcordia standards.²

Based on this protocol developed, test procedures and acceptance criteria for a series of vibration, thermal-vacuum, and radiation exposure tests were developed for selected components.³ Northrop Grumman in Albuquerque led the effort in vibration and thermal (no vacuum) testing of these components at the Aerospace Engineering Facility (AEF) on Kirtland Air Force Base (KAFB), NM. The results of these tests have been evaluated. Aerospace Corporation led the effort in destructive physical analysis and radiation testing of these components at their facility in El Segundo, CA.

This paper discusses the vibration and thermal testing that was executed to validate the test protocol. The lessons learned will aid in future assessments and definition of space qualification protocols. This project was sponsored by the United States Air Force, Air Force Materiel Command, Air Force Research Laboratory (AFRL), 3550 Aberdeen Avenue SE, KAFB, NM 87117-5776, with Jackson and Tull as the prime contractor, under contract number F29601-01-D-0078.

1.1. *Test Mission*

The primary goal for the Bright Light effort is a completed taxonomy that lists all relevant laser components, modules, subsystems and interfaces, and cites the documentation for space-qualification of each of these all the way to the system-level. A validated protocol for the space qualification of DPFLs was the result of this effort, where validation via selected tests was mostly limited to the component-level. It is the aim of this effort to validate selected aspects of the protocol with the limited set of tests proposed in the Bright Light test plan.³

1.2. *Background*

The proposed protocol was tested using selected articles. Test articles for this phase of the program were limited to individual components (or units) and parts (e.g. fibers). The test articles did not include subsystems or systems. Fig. 1 illustrates three (3) generic systems showing the various types of components and parts composing a fiber

* Currently with LSM Services, Inc., 3200 Carlisle NE, Albuquerque, NM 87110

** Currently with the Oregon National Guard

¹ "Background Survey of Work Related to Space Qualification of Laser Systems," S. Falvey, S. Hendow, B. Nelson, L. Thienel, Maj. T. Drape, Col. N. Anderson, 2005 AMOS Technical Conference, September 2005, Maui, HI.

² "Qualification of Fiber Lasers and Fiber Optic Components for Space Applications," S. Hendow, S. Falvey, B. Nelson, L. Thienel, Maj. T. Drape, SPIE LASE 2006, Conference 6102-59.

³ Bright Light Test Plan, Version 4.1, 19 December 2005.

laser. These components and parts may not be available commercial-off-the-shelf (COTS), and, in fact, many are custom articles, or newly developed by the manufacturer.

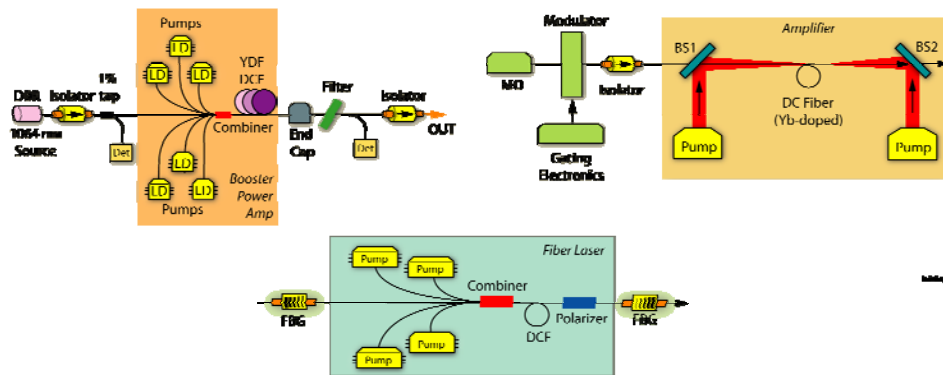

Figure 1. Example generic fiber laser systems.

Components representative of major items within a Yb-doped DPFL were selected for testing, to aid in the development of a generic protocol for space qualification of these DPFLs. Selection of the components was based on guidelines to test multiple models of typical laser fiber components.

If the program were to actually qualify the components, extensive pre-purchase activities would have been performed. Prior to ordering components a site survey would have been performed to discuss and review the components’ materials and parts list to determine the suitability for flight. If any materials were found that were not suitable for flight, changes would have been included in the order. Suitability for vibration, thermal, vacuum, and radiation environments would all be reviewed. Once the suggested changes were incorporated, a determination would be made as to whether or not there remained reasons for vacuum testing (questionable hermetic seals, etc.). If material changes could not be made or if materials information could not be provided then vacuum testing would be performed. Many of these issues were not dealt with since they were outside of the focus for this effort to assess and update the protocol.

1.3. Test Article Selection

A list of potential fiber laser components and parts, including fibers, from various different vendors as potential candidate samples for testing was generated. This list was reviewed and concurred with by the task order officer and then these components and parts were procured. The test articles that were selected are shown in Table 1. There were nominally five of each article procured, providing one for destructive physical analysis (DPA), three for environmental testing, and one to serve as a spare. A goal of the effort was to test two models (i.e. different manufacturers) of each type of article selected, representing different technologies for the same type of device. Selection was based on relevance to high-power fiber lasers in space applications at 106x nm.

Table 1. Selected Test Articles

Component or Part	Description
Double-Clad Ytterbium-doped Fibers	<ul style="list-style-type: none"> Wide-mode area Photonic crystal Various doping concentration Various manufacturers
Combiners	<ul style="list-style-type: none"> 6+1 : 1 16 : 1
Fiber Bragg Gratings	<ul style="list-style-type: none"> ASE Filter Custom
Isolators	<ul style="list-style-type: none"> Fiber pigtailed unit High power bulk unit
Pump Laser Diodes	<ul style="list-style-type: none"> 915 and 976 nm Pigtailed, multimode, no TEC, and high power
Laser Diode Seed Sources	<ul style="list-style-type: none"> Distributed Bragg reflector, with TEC, pigtailed
Pump-Combiner Modules	<ul style="list-style-type: none"> Integrated module using OFS combiner, has 6 laser diodes, 7:1 combiner, with TEC

1.4. Test Objectives

The objective of the environmental tests executed as part of this task was to verify the test protocol developed under Bright Light. There were some aspects of this task that are different than nominal since we were testing the protocol and not space qualifying the test articles. Following the objective of the test program to verify the test protocol and not to directly qualify the selected test articles, certain assumptions were made from which the environmental test program was defined. The assumptions for the vibration and thermal tests performed by Northrop Grumman are discussed in this paper.

The order of testing as given in the protocol⁴ is vendor research (materials analysis), DPA, vibration, thermal/vacuum, and radiation. Therefore the vibration testing was performed first, followed by thermal testing. Performance measurements for each article were taken in the laboratory prior to and after each test to determine if any degradation in article performance occurred.

Nominal loads for component-level vibration testing are 14.1g_{rms}. Pre- and post-vibration performance measurements were made to determine if any degradation in component performance was observed. In addition, the power spectral density (PSD) outputs of the vibration sensors were examined for any resonances indicating potential failure of the component. The nominal loads for part-level vibration testing are different than that for component-level, at 20g_{rms}. The only test articles at the part-level were the fibers which were not vibration tested due to the lack of applicability to testing of the protocol, since fibers would be secured in a system and tested at that level during qualification. The non-fiber articles were all at the component-level.

Since the materials analysis was being conducted in parallel to these tests, and not in the order outlined in the protocol, we had to assume that the materials in the test articles were suitable for flight. Hence, the decision was made that the components would be subjected to thermal cycling only, instead of normal thermal-vacuum testing. In addition, the thermal cycling range (minimum to maximum temperatures) was altered from that defined in the protocol for the active laser components, due to their fragile nature and expensive cost. In reality this is not a problem since an acceptable limited operational range for these components can be defined when part of a flight system.

1.5. Test Methodology

The test articles were evaluated against the protocol developed in vibration and thermal environments.⁴ With the exception of one article for control and one for DPA, all component-level articles received all tests. The part-level articles received thermal cycling tests only. The order of the testing was vibration, then thermal cycling. The assumptions made for the test objectives were discussed above.

1.6. Scope and Limitations

The scope was limited to the specific vibration and thermal environments chosen (typical NASA/Goddard Space Flight Center levels). These environment conditions are summarized in Reference 4. There were some aspects of this task that are different than nominal due to the fact that we were testing the protocol and not space qualifying the test articles. Such aspects included no vibration testing of part-level articles (Yb fibers), thermal cycling only (no vacuum), and reduction in temperature range for thermal cycling of the active laser components.

2. TESTING OVERVIEW

The vibration and thermal tests were conducted starting from mid-August 2005 through December 2005, with the exception of Isolator B which didn't arrive until March 2006. The tests were performed in batches, as illustrated in Table 2. The pre- and post-test performance measurement activities were conducted in laboratory #3 at the Northrop Grumman Information Technology facility in Albuquerque, NM. Vibration and thermal cycling testing were performed at the AFRL AEF at Kirtland AFB, NM.

Table 2. Component Testing was done in Batches

⁴ "Taxonomy and Qualification Protocol of Fiber Laser Systems for Space Applications," S. Hendow, CDRL A002, 27 July 2005.

Component Testing Grouping and Sequencing		
Test Batch	Vibration	Thermal†
1	<ul style="list-style-type: none"> ▪ Isolator A ▪ Combiner B 	<ul style="list-style-type: none"> ▪ Fiber A ▪ Fiber B ▪ Combiner A ▪ Combiner B
2	<ul style="list-style-type: none"> ▪ Fiber Bragg Grating A ▪ Combiner A 	<ul style="list-style-type: none"> ▪ Isolator A ▪ Fiber E (non-active)
3	<ul style="list-style-type: none"> ▪ Laser Diode A (Pump) ▪ Fiber Bragg Grating B 	<ul style="list-style-type: none"> ▪ Laser Diode A (Pump) ▪ Fiber Bragg Grating A ▪ Fiber Bragg Grating B
4	<ul style="list-style-type: none"> ▪ Laser Diode C (PCM) 	<ul style="list-style-type: none"> ▪ Fiber C ▪ Fiber D
5	<ul style="list-style-type: none"> ▪ Laser Diode B (Seed) 	<ul style="list-style-type: none"> ▪ Laser Diode A (Pump) ▪ Laser Diode B (Seed) ▪ Laser Diode C (PCM)
6	<ul style="list-style-type: none"> ▪ Isolator B 	<ul style="list-style-type: none"> ▪ Isolator B (non-active)

† Active measurements were conducted, unless otherwise noted

Performance measurements for each article were taken in the laboratory prior to and after each test (vibration and thermal) to determine if any degradation in article performance occurred. The performance measurements were selected based on the dominant component failure modes. Table 4 lists the parameters to monitor and types of measurements to perform for the different components’ dominant failure modes.

The performance measurements utilized three experimental setups:

- 1) Insertion Loss (IL) to measure the transmitted light throughput. These measurements were taken for fibers, combiners, isolators, and fiber Bragg gratings (FBGs). This same setup was used to also measure the amount of isolation for the isolator components.
- 2) Light-Current (LI) curve to measure the output power as a function of current and obtain the threshold value. These measurements were taken for the laser diodes, laser seed source, and Pump Combiner Modules (PCMs).
- 3) Spectrum to measure the center wavelength, 3dB bandwidth, in-band reflectivity, and sideband rejection. These measurements were taken for the laser diode pumps, laser seed source, FBGs, and PCMs.

The optical properties measured for the performance metrics listed above, for each component, are listed in Table 3. Note that the spectrum for the PCMs was not measured due to the complexity of the splice needed to connect to the Optical Spectrum Analyzer (OSA).

Table 3. Optical Properties measured for Performance Metrics

Component	Test Performance Metrics	Test Type
Ytterbium Fibers	IL	Passive, before and after
Combiners, Pump	IL	Passive, before and after
Fiber Bragg Gratings (FBGs)	IL, Isolation	Passive, before and after
	Spectrum	Active thermal testing
Isolators	IL, Isolation	Passive, before and after
Laser Diode Pumps	LI	Passive, before and after
	LI, Spectrum	Active thermal testing
Pump-Combiner Modules (PCMs)	LI, Isolation	Passive, before and after
	LI, Spectrum*	Active thermal testing
Laser Seed Source	LI	Passive, before and after
	Spectrum	Active thermal testing

* Not tested due to complexity of splice to connect with OSA

Table 4. Parameters to Monitor for the Dominant Component Failure Modes
(IL = Insertion Loss, TEC = Thermo-electric cooler, λ = wavelength)

Item	Parameter to Monitor	Type of Measurement	Dominant Failure Modes
Fiber (all)	IL of core	Active	• Increase in IL leading to optical damage during operation at peak power (catastrophic)
	Absorption rate of clad at pump λ	Before and after	
	Absorption and emission spectra	Occasional	
Combiner (ITF, JDSU)	IL, thru fiber	Active	• Decrease in transfer efficiency from the pump arm to output cladding and overheating of combiner.
	IL, three of multimode input ends	Before and after	
Pump LD (JDSU)	Output Power	Active	• Gradual degradation or sudden failure with radiation exposure. • High environmental temp may lead to wavelength drift
	λ & spectrum	Active	
	Threshold	Before and after	
Pump-Combiner Module (Alfalight)	Output power at max current	Active	• Gradual degradation with radiation. • Overheating at high environmental temp may lead to wavelength drift. • Combiner may have thermal drift.
	λ and spectrum at max current	Active	
	TEC current at 20°C	Before and after	
	Power vs. current	Before and after	
Fiber Bragg Grating (FBG, SPI, Corvis)	Isolation	Before and after	• Athermal property may get damaged leading to wavelength drift (catastrophic). • IL degradation with radiation damage.
	Reflectivity	Occasional	
	Reflectivity spectrum	Occasional	
Laser Seed Source (Sacher)	Sideband reflectivity	Before and after	• Wavelength drift. • Gradual or sudden failure due to high thermal operation or radiation exposure.
	Output power at max current	Active	
	Output spectra	Occasional	
	Output power vs. current	Before and after test	
Isolator, fiber pigtailed (Novawave)	TEC current at 20°C	Before and after	• Increase in IL with vibration, thermal or radiation exposure.
	IL	Active	
Isolator, free space (EOT)	Isolation	Before and after test	• Increase in IL with radiation. • Degradation of isolation. • Misalignment with vibration.
	IL	Before and after test	

To perform the IL measurements, fiber pigtailed were added to the components, where possible, on both the input and output ends. As can be seen from Table 3, these components included the fibers, isolators, combiners and FBGs. Pigtailed were also added to the output fiber of the laser diode pumps since those originally provided with the pumps were only 1 meter in length. Further discussion regarding splices and issues involved is presented in Section 2.3 on Pigtail Splicing.

2.1. Test Measurements

The performance parameters listed in Table 3 were measured for the respective components, for the defined environmental tests.

2.2. Test Layouts

The test layouts for the performance measurement setups, the vibration testing setups, and thermal testing setups are discussed in this section.

2.2.1. Performance Measurement Setups

The IL (and isolation) performance measurement setup is shown in Figure 2. This setup was used to measure the transmitted throughput for the device-under-test (DUT) at a wavelength of 1064 nm. The isolation measurement is just the IL measured in reverse for the component. The reference leg monitored the laser power output variation as a function of time, so that this variation could be later removed from the data. The laser throughput was measured before and after insertion of the DUT, to be able to calculate the IL. The splice losses with and without the DUT were taken into account. The data acquisition system (DAQ) recorded 1000 data points as a function of time onto the PC for later analysis.

The measurements that were made for LI performance include the power output as a function of the current setting, and the threshold current value where the power output is first observed. These measurements were performed at the default TEC temperature of 25°C for the Laser Diodes B and Laser Diodes C components. The wavelengths of these lasers for which measurements were made are 910 nm, 976 nm, and 1060 nm for the Laser Diodes A, Laser Diodes C, and Laser Diodes B, respectively.

The experimental setup to measure the spectrum of the FBG components is shown in Figure 3. To measure the spectrum for the active laser components, the Newport detector in each respective setup for LI performance measurements was replaced with the OSA. A cable with an FC/APC connector was spliced into the setup for mating to the OSA. The OSA recorded the spectrum information, including power throughput, center wavelength,

spectral full width half max (FWHM), and the side-bands. The insertion loss was computed. The splice losses with and without the DUT were taken into account.

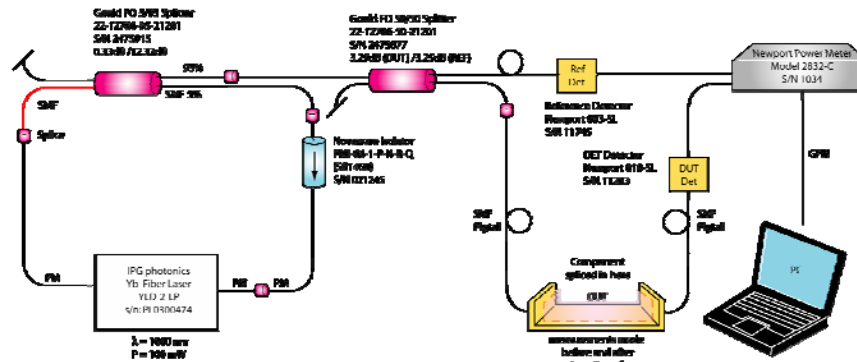

Figure 2. IL (and isolation) performance measurement setup.

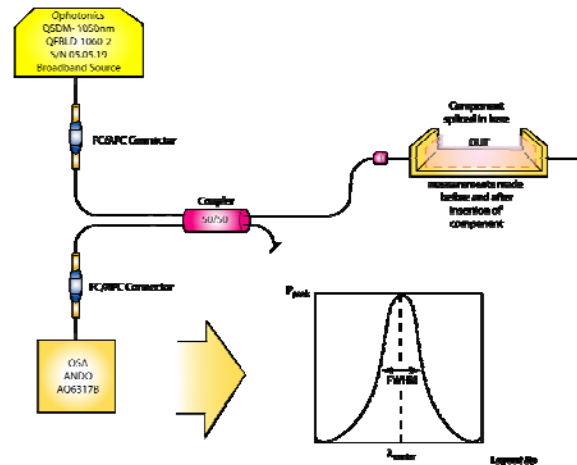

Figure 3. FBG LI performance measurement setup.

2.2.2. *Vibration Testing Setups*

The vibration tests were passive, i.e., none of the components were powered (or lit) during testing. There was also no data collection during the vibration tests other than the vibration test apparatus PSD. The components for vibration testing are listed in Table 1, excluding the Yb fiber. The vibration tests were conducted in batches as shown in Table 2. Note that the groupings are designated based on parallel processing of the various components.

There were three (3) samples of each component listed in Table 2 that were subjected to the vibration tests. One sample of each component within a batch was tested first, followed by testing of the remaining samples. When tested, all components were attached to the vibration mount fixture and vibrated in 3 axes (x, y, and z). The vibration apparatus with the mount fixture is shown in Figure 4. The components were mounted to the 16-inch diameter fixture in the desired orientation (x, y, or z). Changing the orientation of this mounting fixture with respect to the apparatus changed the direction of vibration.

2.2.3. *Thermal Testing Setups*

Most of the components were continuously monitored and data recorded during the thermal cycling tests. The thermal tests were conducted in batches as listed Table 2. For flexibility in performing the complete thermal cycle profile for any batch of components, the cycles were interrupted on the upward slope at the ambient room temperature for insertion of additional components or removal of completed components, to aid in testability (and scheduling) of the components. This is a common procedure used when testing many batches of components.

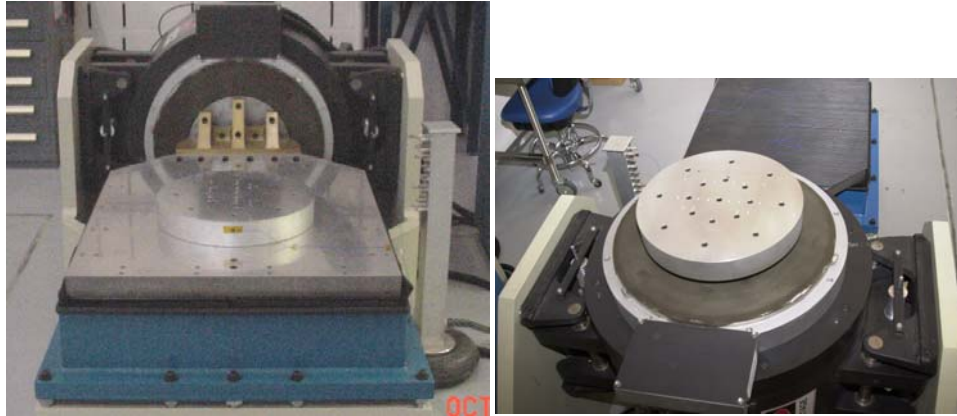

Figure 4. Vibration apparatus for x, y (left) and z (right) orientations.
The 16-inch diameter fixture is shown attached to the vibration apparatus.

2.3. *Pigtail Splicing*

To perform the IL measurements, fiber pigtails were added to the components, where possible, on both the input and output ends. These components included the fibers, isolators, combiners, and FBGs. Pigtails were also added to the output fiber of the laser diode pumps since those originally provided with the pumps were only 1 meter in length. The splicing was typically done with a fusion splicer that controls the alignment of the two fibers to keep losses as low as possible.

The ideal splice of one fiber to another would have two fibers that are optically and physically identical and aligned on their center axes. However, in the real world, system loss due to fiber splices is a factor.⁵ IL is the primary consideration for performance. If two different types of fibers are connected, then numerical aperture (NA) mismatch loss and diameter mismatch loss must be accounted for. NA mismatch loss occurs when the NA of the transmitting fiber (t) is larger than that of the receiving fiber (r). NA mismatch loss is illustrated in part A of Figure 5, where the approximated formula for the calculated loss is also displayed.

The core diameter mismatch occurs when the core diameter of the transmitting fiber (t) is larger than the core diameter of the fiber at the receiving end (r), as shown in part B of Figure 5. Cladding diameter mismatch is similar to core diameter mismatch loss except the cladding of the transmitting fiber differs in diameter from the cladding of the receiving fiber. Either mismatch prevents the cores from aligning. Both types of diameter mismatch loss are approximated by the formula given in part B of the Figure.

Concentricity, also known as eccentricity, occurs because the core may not be perfectly centered in the cladding. Ellipticity or ovality describes the fact that the core or cladding may be elliptical rather than circular. The alignment of the two elliptical cores will vary depending on how the fibers are brought together. These forms of connector loss are illustrated in part C of Figure 5.

The Fujikura FSM-40PM arc fusion splicer was utilized to perform most splicing operations. The splicer uses image processing to identify abnormal conditions that sometimes occur during the splicing process⁶. A small portion of these defects sometimes goes undetected and a poor quality splice occurs. The fiber image on the monitor is visually inspected to confirm acceptance or rejection during the various stages of the splicing process. The splicer measures and reports each fiber's cleave angle. An audible alarm sounds and an error message is displayed when the threshold of cleave angle error is exceeded, or the state of the fiber end-face is unacceptable (e.g., a crack, lip, or incline is present). The splicer performs an alignment operation and produces a high voltage arc discharge to fuse the fibers together. The splice is visually examined for possible deformities that could have happened during the splicing process due to contaminants located on the surface or end-face. The loss estimation

⁵ "Fiber Optic Reference Guide, A Practical Guide to the Technology," David R. Goff, 2nd edition, Focal Press, 1999.

⁶ Fujikura FSM-40PM Arc Fusion Splicer Instruction Manual, KSP75-1002-16-01 (3).

function of the splicer reports the cleave angles in degrees and splice loss in dB.

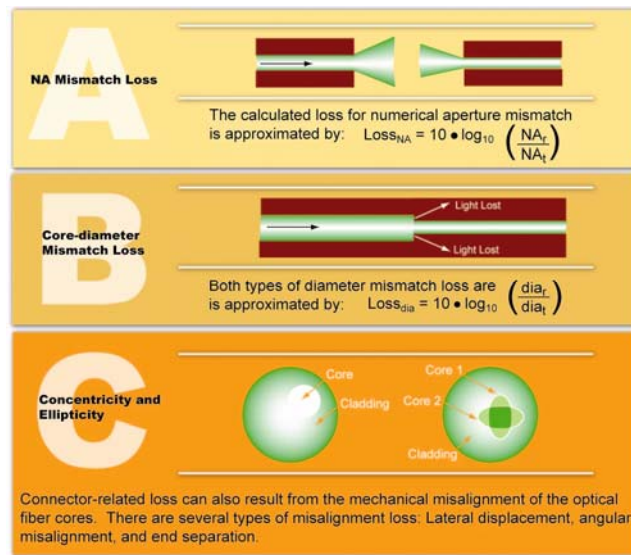

Figure 5. Typical textbook splice losses.⁵

The FSM-40PM splicer has 40 splice modes whose settings could be changed. Before splicing, the most appropriate splice mode is selected for the fiber that is spliced. In each of the 40 auto splice modes, the following settings are stored: (1) setting to control the arc discharge, (2) setting to calculate estimated loss, (3) setting to control aligning and splicing operations, and (4) threshold at which an error occurs. These settings finely control the aligning and splicing operations. The splice mode settings are optimized according to the types of fibers. The auto splice modes used for the Bright Light effort include numbers 14 and 23. Auto mode 14 is for splicing 400 μ m Panda (PM) fiber to 250 μ m SMF, and auto mode 23 is for splicing 125 μ m SMF fibers together.

Most components tested had fiber pigtailed added to prevent shortening of the original fibers for repeated performance testing before and after each environmental test, and to allow for enough fiber to reach out of the thermal chamber to the DAQ equipment. The Combiners A output fiber was the only component manually spliced. For this process, a Helium Neon laser at 633nm wavelength was used to measure the throughput before and after gluing the fibers together. This value was then extrapolated to a wavelength of 1060nm for estimation of splice loss.

Knowing the splice loss information enables direct comparison of results, due to testing of the components without the loss effects of the splices.

3. TESTING RESULTS

The results of the vibration and thermal (no vacuum) tests in support of the Bright Light protocol development effort are presented in this section. Individual component results for the performance measurement tests and the environmental tests are given in the sections that follow. Table 5 shows the summary of the component testing. Several components were seen to degrade during environmental testing and handling, and three components failed during testing.

Note that degradation is a subjective rating made by the author based on relative performance measurements of the particular component before and after testing. And although degraded, the component may still perform within the mission requirements, but not within the vendor specifications. The rating of “failure”, however, is not subjective and due to the component actually failing.

Table 5. Component Testing Results Summary

Component	Description	Item #	Degradation (D) or Failure (F) Observed			Component	Description	Item #	Degradation (D) or Failure (F) Observed		
			Vibration	Thermal	Handling				Vibration	Thermal	Handling
Fiber A	PM SMF 5/125/250µm	1				Combiner A	6+1 : 1 SMF core fiber MMF port fibers	1			
		2	N/A					2	D	F	
		3			D			3			
Fiber B	30/250µm DCF with FC/PC connectors	1				Combiner B	16 : 1 MMF input fibers DCF output fibers	1	D	D	
		2	N/A	F				2			
		3						3			
Fiber C	30/250/400µm large mode area fiber	1				FBG A	Custom, ASE Filter, 1064 nm, Athermal Package	1			D
		2	N/A					2			
		3						3			
Fiber D	45/49/250µm fiber under development	1				FBG B	ASE Filter, 1062 nm, Demonstrator	1			
		2	N/A					2			
		3						3			
Fiber E	40/170/650µm high NA fiber, with ends sealed	1				Laser Diode A	Pump, Pigtailed, multimode, no TEC, high power	1			
		2	N/A	N/A				2			
		3						3			D
Isolator A	1064nm, PM, single stage, pigtailed	1				Laser Diode B	Seed Source, DBR with TEC, pigtailed, low power	1			
		2						2			
		3						3			D
Isolator B	Bulk unit	1	N/A	D		Laser Diode C	PCM, integrated using 7:1 combiner & 6 LDs, with TEC	1		D	
		2	F	N/A				2	D	D	
										3	

Only three components were seen to fail as a result of these tests. These components include a Fiber B, a Combiner A, and an Isolator B. The Fiber B and Combiner A components failed during thermal testing. The Fiber B split on chamber start and the Combiner A failed after one full cycle. Isolator B failed during vibration testing when the component physically shook apart. Suggestions are made in Section 4 on Lessons Learned, to aid in future assessments and definition of space qualification protocols.

Note that although most components passed vibration testing to 14.1G, three components did degrade after vibration testing and continued to degrade further in thermal testing. These three components were a Combiner A, a Combiner B, and a Laser Diode C, as indicated in Table 5.

The three components that degraded due to handling include a Fiber A, an FBG A, and a Laser Diode A. Fiber A did not degrade due to thermal testing, as seen in the actively collected data; however, the IL for this fiber decreased by a factor of 2 in the post-thermal performance measurement. Since the fiber was snagged upon removal from its packaged container, it is concluded that this degradation is due to handling. The FBG A fiber was very fragile and broke on both the input and output sides of the FBG as its position-holding tapes were removed from the vibration fixture. The FBG fibers were re-spliced without any loss of throughput, but these are indicated as a handling issue. The Laser Diode A performed well during thermal testing and during post-thermal performance measurements while in the thermal test setup. However, once the device was de-soldered from the thermal test setup to test individually, the performance of this device was degraded. The heating process to remove the solder connections injured the Laser Diode, and this is considered a handling issue.

Although components were seen to degrade, these are still operational and may still perform within the mission requirements, as defined by the particular system design. And even though some components failed during our testing, it was only one of three provided components. These interesting results emphasize the need for testing of multiples of components as outlined in Telcordia testing procedures. It was the purpose of these tests to assess the protocols for testing components, not testing of the components themselves. Therefore, no recommendations for the space qualification of any particular component are made, only lessons learned that will aid in the development of this protocol.

3.1. Performance Measurements

Performance measurements for each component were taken in the laboratory prior to and after each environmental test to determine if any degradation in performance occurred. Since we are interested in the comparison of relative measurements, not absolute, only the splice losses measured by the arc fusion welder were taken into consideration, and not the losses due to NA mismatch or core-diameter mismatch.

Since the fibers were not vibration tested, pre-vibe performance measurements were not taken. The inconsistency

in the performance measurements for thermal batch #1 components (Fibers A and Fibers B, Combiners A and Combiners B) led to a dedicated setup for performance measurement testing for all future measurements. Due to limits in our ability to test polarization effects, the Combiners A displayed negative IL in some cases. The Fibers E were not tested due to the complexity of the splices and inadequate splicing equipment to handle the size of the core.

The applicable components for performance measurements of the spectrum include the Laser Diodes A, the FBGs A, the FBGs B, the Laser Diodes B, and the Laser Diodes C. The Laser Diodes C spectrum was not measured due to the complexity of splice to connect to the OSA. The Laser Diodes A and Laser Diodes B spectra were measured actively during thermal testing and not as part of the performance measurements.

The LI performance measurements for the active lasers, the slope efficiency, were measured over the 20% to 80% emission range of the device. The LI curves for these components readily shown that a Laser Diode A, a Laser Diode B, and all the Laser Diodes C, degraded in performance.

3.2. Vibration Testing Results

The conditions for vibration testing, as defined in the protocol, are shown in Table 6. The components were subjected to both a random vibration spectrum as well as a sine sweep. The vibration tests were done in three axes (x, y, and z). Also, the vibration apparatus performs a ¼G sweep before and after component testing to verify system operation.

The components were characterized before vibration and then again after vibration to determine if any degradation in component performance was observed. Degradation is a subjective rating made by the author, and although degraded, the component may still perform within the mission requirements but not within the vendor specifications.

Table 6. Vibration Testing Levels*

Frequency (Hz)	Component Testing	Units
20	0.026	G ² /Hz
20-50	+6	dB/octave
50-800	0.16	G ² /Hz
800-2000	-6	dB/octave
2000	0.026	G ² /Hz
Overall	14.1	G _{rms}

* 3 minutes per axis

The typical vibration PSDs for the vibration mounting fixture, sine sweep and random sweep are shown in Figure 6. The vibration mounting fixture itself was shown in Figure 4.

The Laser Diodes C PSD plots displayed resonances in the sine sweep at ~600 and ~1200 Hz. The reason for this was the placement of that vibration sensor on the lid of the device. These results were expected since the lid is a thin piece of metal suspended above the internal components and only secured around the edge of the device.

The results of the vibration testing are shown in Table 7. Typically only one channel was used with its sensor placed either on the front of the fixture, or on the top near the center amongst the components. Most of the components were too small to accommodate a sensor, so it was placed on the fixture itself. The Laser Diodes C in vibration batch #4A and #4B were large enough to accommodate a sensor, so additional channels were run to measure the PSDs on the devices as well as on the mounting fixture. The auxiliary RMS output is that measured for the component (placed on the fixture), and the control RMS output is that measured by the control sensor for the operator’s diagnostics.

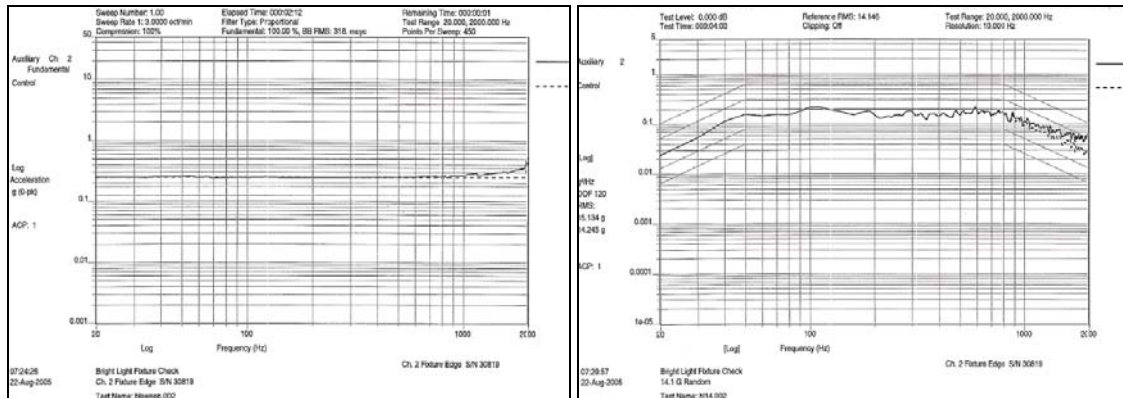

Figure 6. Typical vibration PSD for vibration mounting fixture; sine (left) and random (right) sweep.

3.3. Thermal Testing Results

All components listed in Table 2 were continuously monitored during the thermal environment testing, with the exception of the Fibers E and Isolators B. The range of cycling, minimum to maximum temperature, was batch dependent. Component vendors were contacted to determine their survivability range.

Thermal batches #1 through #4 were cycled from -40°C to +70°C. Thermal batch #5 was cycled from -10°C to +60°C. The limiting component for batch #5 was the circuit boards in the Laser Diodes C. It was known through the vendor that these circuit boards would not survive the same cycling range as the other batches and therefore the cycling range was reduced. And even though the vendor suggested cycling range for the Laser Diodes B was less than the test range, their operating and storage range values were adequate for this testing.

Table 7. Vibration Test Results

Batch	Axis	Channel	RMS Output (G)		Post Vibration Component Status
			Auxiliary	Control	
1A	X	1	14.109	14.109	No damage or degradation
		Y	14.219	14.219	
		Z	14.124	14.124	
1B	Y	1	13.966	13.966	No damage or degradation
		Y	14.340	14.340	
		Z	14.021	14.021	
2A	X	1	14.210	14.210	No damage or degradation
		Y	14.369	14.369	
		Z	14.212	14.212	
2B	X	1	14.268	14.268	1 Combiner A saw ~2.2 dB degradation
		Y	14.163	14.163	
		Z	14.177	14.177	
3A	X	1	14.103	14.103	1 Laser Diode A saw 1.44±0.27 dB degradation
		Y	14.079	14.079	
		Z	14.332	14.332	
3B	Z	1	14.181	14.181	No damage or degradation
		Y	14.271	14.271	
		X	14.297	14.297	
4A	X	1	14.115	14.115	No damage or degradation
		2	14.452	14.115	
		Y	14.118	14.118	
4B	Y	2	14.823	14.118	1 Laser Diode C saw 7.8% degradation in output power
		1	14.127	14.127	
		Z	56.218	14.127	
5A	X	1	14.373	14.373	No damage or degradation
		2	14.633	14.373	
		3	14.344	14.373	
5B	Y	1	14.106	14.106	1 Laser Diode B saw a +5.7% change in the output power
		2	14.614	14.106	
		3	14.645	14.106	
6A	Z	1	14.268	14.268	1 Isolator B physically shook apart
		2	51.253	14.268	
		3	50.728	14.268	

The dwell time at the minimum and maximum temperature extremes, and the number of cycles, was based on the type of component. The determination of the number of cycles was based on the mass of the component. Components with low mass were cycled at 2°C per minute with 25 minute plateaus, and higher mass components were cycled at 2°C per minute with 100 minute plateaus. The longer plateaus for the higher mass components were selected to provide time for the component to reach thermal equilibrium at the rate of 2°C per minute. The thermal cycling profiles for short and long dwell times are illustrated in Figure 7. The test was automated to minimize the amount of test operator interaction required. The duration of the test was nominally 11 days for each batch, with the exception of batch #5. It turns out that all of the higher mass components were tested together in batch #5. The batch #5 thermal tests were run for 40 cycles instead of the listed 50 cycles due to scheduling of the facility resources. This reduced time was not an issue since we were already testing a reduced temperature range, and it was the protocol procedures that were really being tested, not the components themselves. Batch 6 (Isolator B) underwent 50 cycles from -40 to +70°C with 100 min plateaus.

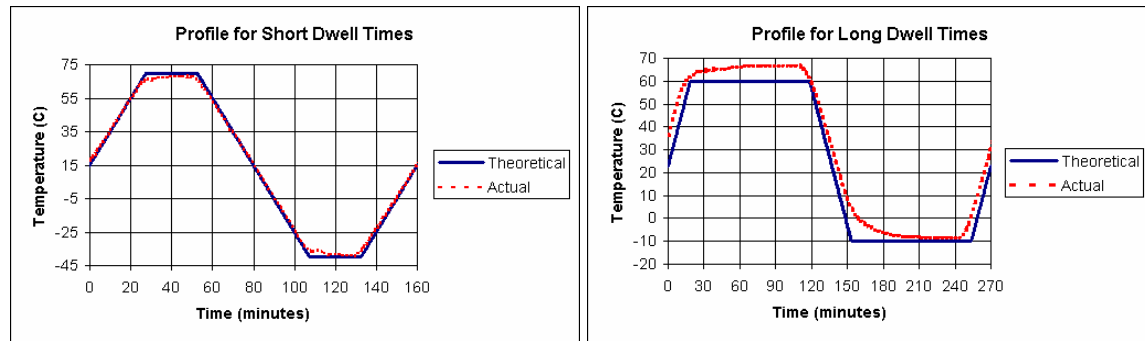

Figure 7. Thermal cycling profile for batches #1 through #4 (left) and batch #5 (right).

For flexibility in performing the complete thermal cycling profile for any batch of components, the cycles were interrupted on the upward slope at the ambient room temperature for insertion of additional components or removal of completed components, to aid in testability of the components. This is a common procedure used when testing many batches of components. Initially, the Fibers A and Combiners A components of batch #1 was inserted into the chamber, then the Fibers B were added the next day, followed by adding the Combiners B 3 days later, to completely assemble batch #1. The chamber was opened again 3 days later to insert batch #2. When batch #1 was completed, the chamber was opened again to allow removal of those components and insertion of batch #4 components. The thermal testing results were shown in Table 5.

4. LESSONS LEARNED

Components representative of major items within an Yb-doped DPFL were selected for testing, to aid in the development of a generic protocol for space qualification of these DPFLs. Based on this protocol developed, test procedures and acceptance criteria for a series of vibration, thermal/vacuum, and radiation exposure tests were developed for selected components. Northrop Grumman led the effort in vibration and thermal (no vacuum) testing of these components at the AEF on Kirtland AFB, NM.

The results of the tests conducted have been evaluated. In an effort to aid in future assessments and definition of space qualification protocols, recommendations for areas of improvement were provided, in addition to contributing to a growing repository of valuable information and lessons learned. We have provided a very straight-forward discussion of lessons learned to include actions that went wrong, mistakes made, improvements desired (equipment and procedures), including assessments applicable to upgrading the protocol. We emphasize that the errors reported were due to the developmental nature of the program and to the typical struggles of establishing protocol for a new series of test procedures.

The lessons learned have naturally fallen into five (5) separate categories, applicable to the major areas of concern for testing of fiber laser components: 1) fiber handling, 2) test equipment, 3) component testing, 4) data acquisition, and 5) safety issues. It was the goal to aid in future efforts for performing these types of tests. The lessons learned are being incorporated into the revised protocol.

5. SUMMARY and CONCLUSIONS

The test protocol for space qualification of Yb-doped DPFLs was updated as a result of this effort. Testing was performed to improve the fidelity of the draft test protocol. The revised protocol documents appropriate tests that are performed at the part, component, and subsystem level to increase probability of success on orbit. The lessons learned will aid in future assessments and definition of space qualification protocols, and provide recommendations for areas of improvement. The lessons learned are being incorporated into the revised protocol. The revised protocol will have more of a bottoms-up view, including a utilitarian approach, where the actual test procedures that were run are attached. Improvements to the protocol document also include discussions on COTS vendor interaction and involvement, including engineering issues, survivability and reliability, materials analysis at process start, and an expanded fiber splicing section.

The primary objective of this effort was to test the protocol and its procedures for space qualification of COTS fiber laser components, but testing of these components does not answer the question of how well they performed for space qualification. The data results presented here do not reflect on vendors or their abilities to produce products for space applications, as many vendors are eager to meet space qualification requirements. A subjective judgment for space qualification of components is summarized and presented in Table 8.

Table 8. Component Testing Summary

Component	Space Qualification		
	DPA	Vibration	Thermal
Fiber A	Acceptable Results	Acceptable Results	Acceptable Results
Fiber B	Acceptable Results	Acceptable Results	Unacceptable Results
Fiber C	Acceptable Results	Acceptable Results	Acceptable Results
Fiber D	Acceptable Results	Acceptable Results	Acceptable Results
Fiber E	Acceptable Results	Acceptable Results	Acceptable Results
Isolator A	Caution, more data needed	Acceptable Results	Acceptable Results
Isolator B	Unacceptable Results	Unacceptable Results	Caution, more data needed
Combiner A	Acceptable Results	Caution, more data needed	Unacceptable Results
Combiner B	Acceptable Results	Caution, more data needed	Caution, more data needed
FBG A	Acceptable Results	Acceptable Results	Acceptable Results
FBG B	Caution, more data needed	Acceptable Results	Acceptable Results
Laser Diode A	Acceptable Results	Acceptable Results	Acceptable Results
Laser Diode B	Caution, more data needed	Acceptable Results	Caution, more data needed
Laser Diode C	Caution, more data needed	Caution, more data needed	Caution, more data needed

Key:	
Acceptable Results	Acceptable Results
Caution, more data needed	Caution, more data needed
Unacceptable Results	Unacceptable Results
TBD	TBD

6. ACKNOWLEDGEMENTS

This project was sponsored by the USAF, AF Materiel Command, AFRL, 3550 Aberdeen SE, KAFB, NM 87117, with Jackson and Tull as the Prime Contractor, under contract number F29601-01-D-0078. I wish to acknowledge the following participants without whose help I could not have accomplished all that was done: Pat Cavenee, Matthew Larsen and Will Graveman from Northrop Grumman, Joseph Kelley from Jackson and Tull, Melanie Ott from NASA/Goddard Space Flight Center, Dr. Sami Hendow from Spectra-Physics in San Jose, CA, and Colonel Norman Anderson from the USAF/AFRL.

For further information, send an email request to suzanne.falvey@ngc.com. A detailed final report including the background study, test plans, reports from all subcontractors (e.g. DPA and radiation testing of these components by Aerospace Corporation) has been written and uploaded into the Defense Technical Information Center (DTIC) scientific and technical information network and can be accessed by Department of Defense contractors. The DTIC report number is TR-2006-1095.