

**Paper for the 10<sup>th</sup> International Command & Control Research & Technology Symposium**

Title: *Establishing a Community of Interest (COI) for Global Force Management*

Submitted by: Sam Chamberlain, Ph.D  
U.S. Army Research Laboratory  
ATTN: AMSRD-ARL-CI-CT  
APG, MD 21005-5067  
410-278-8948  
Fax: 2934 / 9223  
[sam.chamberlain@us.army.mil](mailto:sam.chamberlain@us.army.mil)  
<http://www.arl.army.mil/~wildman>

and

Mike Boller  
Science Applications International Corporation  
In Support of The Joint Staff / J-8 / MASO  
8000 Joint Staff Pentagon  
Washington, DC 20318-8000  
703-614-6772  
[michael.oller@js.pentagon.mil](mailto:michael.oller@js.pentagon.mil)

and

George Sprung  
Chief, Model and Analysis Support Office  
The Joint Staff / J-8 / MASO  
8000 Joint Staff Pentagon  
Washington, DC 20318-8000  
703-693-4605  
[george.sprung@js.pentagon.mil](mailto:george.sprung@js.pentagon.mil)

and

Victor Badami, LTC, USA  
Deputy, Model and Analysis Support Office  
The Joint Staff / J-8 / MASO  
8000 Joint Staff Pentagon  
Washington, DC 20318-8000  
703-693-2552  
[victor.badami@js.pentagon.mil](mailto:victor.badami@js.pentagon.mil)

Recommended Track: Policy

# Report Documentation Page

Form Approved  
OMB No. 0704-0188

Public reporting burden for the collection of information is estimated to average 1 hour per response, including the time for reviewing instructions, searching existing data sources, gathering and maintaining the data needed, and completing and reviewing the collection of information. Send comments regarding this burden estimate or any other aspect of this collection of information, including suggestions for reducing this burden, to Washington Headquarters Services, Directorate for Information Operations and Reports, 1215 Jefferson Davis Highway, Suite 1204, Arlington VA 22202-4302. Respondents should be aware that notwithstanding any other provision of law, no person shall be subject to a penalty for failing to comply with a collection of information if it does not display a currently valid OMB control number.

1. REPORT DATE <b>JUN 2005</b>		2. REPORT TYPE		3. DATES COVERED <b>00-00-2005 to 00-00-2005</b>	
4. TITLE AND SUBTITLE <b>Establishing a Community of Interest (COI) for Global Force Management</b>				5a. CONTRACT NUMBER	
				5b. GRANT NUMBER	
				5c. PROGRAM ELEMENT NUMBER	
6. AUTHOR(S)				5d. PROJECT NUMBER	
				5e. TASK NUMBER	
				5f. WORK UNIT NUMBER	
7. PERFORMING ORGANIZATION NAME(S) AND ADDRESS(ES) <b>Army Research Laboratory,ATTN: AMSRD-ARL-CI-CT,Aberdeen Proving Ground,MD,21005-5067</b>				8. PERFORMING ORGANIZATION REPORT NUMBER	
9. SPONSORING/MONITORING AGENCY NAME(S) AND ADDRESS(ES)				10. SPONSOR/MONITOR'S ACRONYM(S)	
				11. SPONSOR/MONITOR'S REPORT NUMBER(S)	
12. DISTRIBUTION/AVAILABILITY STATEMENT <b>Approved for public release; distribution unlimited</b>					
13. SUPPLEMENTARY NOTES <b>The original document contains color images.</b>					
14. ABSTRACT					
15. SUBJECT TERMS					
16. SECURITY CLASSIFICATION OF:			17. LIMITATION OF ABSTRACT	18. NUMBER OF PAGES <b>28</b>	19a. NAME OF RESPONSIBLE PERSON
a. REPORT <b>unclassified</b>	b. ABSTRACT <b>unclassified</b>	c. THIS PAGE <b>unclassified</b>			

## Establishing a Community of Interest (COI) for Global Force Management

### Dr. Sam Chamberlain

U.S. Army Research Laboratory  
ATTN: AMSRD-ARL-CI-CT  
Aberdeen Proving Ground, MD 21005-5067  
410-278-8948  
[sam.chamberlain@us.army.mil](mailto:sam.chamberlain@us.army.mil)  
<http://www.arl.army.mil/~wildman>

### Mr. George Sprung

Chief, Model and Analysis Support Office  
The Joint Staff / J-8 / MASO  
8000 Joint Staff Pentagon  
Washington, DC 20318-8000  
703-693-4605  
[george.sprung@js.pentagon.mil](mailto:george.sprung@js.pentagon.mil)

### Mr. Mike Boller

Science Applications International Corporation,  
In Support of The Joint Staff / J-8 / MASO  
8000 Joint Staff Pentagon  
Washington, DC 20318-8000  
703-614-6772  
[michael.boller@js.pentagon.mil](mailto:michael.boller@js.pentagon.mil)

### LTC Victor Badami, US Army

Deputy, Model and Analysis Support Office  
The Joint Staff / J-8 / MASO  
8000 Joint Staff Pentagon  
Washington, DC 20318-8000  
703-693-2552  
[victor.badami@js.pentagon.mil](mailto:victor.badami@js.pentagon.mil)

### Abstract

The objective for Global Force Management (GFM) is to establish a transparent and universal process to manage, assess and display the worldwide disposition of US forces. This includes US force availability, readiness and capability in order to assess the risks associated with proposed allocation, assignment and apportionment options. Fundamental to GFM and foundational to transformation is the GFM Data Initiative (GFM DI), which addresses organizing force structure data in a joint hierarchal way for integration across Service lines. To address the GFM data problem, provide the data in network centric environment, and manage the data, a Community of Interest (COI), as described in the Net Centric Data Strategy<sup>1</sup> (NCDS)<sup>1</sup>, was established in the summer of 2003. The GFM COI is co-chaired by the Joint Staff, Force Structure, Resources, and Assessment Directorate (J-8)<sup>2</sup> and the Office of the Under-Secretary of Defense for Personnel and Readiness (USD(P&R)).<sup>3</sup> The GFM COI is a governing body now implementing a set of organization servers, maintained by OSD, the Services, and the Joint community, that will provide high resolution, default force structure data for a diverse set of users. This paper describes some of the challenges encountered during the establishment, evolution, and first 18 months of operation of a COI. Not surprisingly, a COI is not a magical solution and it does not displace the difficult task and extensive intellectual efforts required to establish agreements among diverse users of data, even when the data set is restricted.

---

<sup>1</sup> From the Department of Defense Net-Centric Data Strategy, 9 May 2003; see:  
<http://www.defenselink.mil/nii/org/cio/doc/Net-Centric-Data-Strategy-2003-05-092.pdf>

<sup>2</sup> See: <http://www.dtic.mil/jcs/core/j8.html>

<sup>3</sup> See: <http://www.dod.mil/prhome/readiness.html>

## 1. A Community of Interest (COI) Should Be Created To Solve A Problem

In January 2003, the Department of Defense began development of the force structure lay-down for the second rotation of forces to deploy to Iraq. This process, known as the *allocation of forces*, is the Secretary of Defense's responsibility and is based upon recommendations submitted by the joint force provider that are reviewed by the Joint Chiefs of Staff (JCS). In this process, the world-wide disposition of forces is examined and assessed to determine the recommended force rotation based on a number of factors including (but not limited to) current force locations, what their past employment has been, their current readiness status, and the requirements for all Combatant Commanders' plans.

The information requirements for this process are significant and demanding. The process requires detailed data on current information, future commitments, potential capabilities of all forces, and the ability to assess the risk to all existing plans and commitments. Difficulties in developing a recommendation include: the processes of pulling data from multiple Service specific (and some joint) systems, augmenting the data via significant manual, labor-intensive intervention to reconcile inconsistencies, and then applying planner judgment and expertise to resolve the numerous data discrepancies. Today, this process cannot be accomplished with a fine degree of precision in a timely manner, thus requiring multiple reviews and significant planner coordination. In fact, only combat force elements and select enablers are tracked.

In addition to the major combat units, OEF/OIF<sup>4</sup> required specific capabilities supplemented within the theater. Many of these capabilities were met by sourcing only partial units to meet the requirement. As these additional capabilities were added, the tracking of decomposed unit level organizations throughout the process became unmanageable. Moreover, determining residual capability and tracking of remaining partial units was problematic. A new approach had to be developed to be able to handle this process, as exiting systems did not support tracking of decomposed units. Moreover, linkage to combat support (CS) and combat service support (CSS) units were only fully considered after decisions had been made on the combat units.

In an effort to perform this function, the J-8 developed an automated tool to assist in the process. Using only major combat formations, the tool laid out forces allocated to OEF/OIF, the future OEF/OIF allocation, and residual capabilities for apportionment for other Combatant Commanders' contingency planning. Although most of this information is available somewhere, it cannot be easily discovered or accessed in a timely manner, and does not render itself for easy manipulation by computers. The tool is helpful, but does not resolve the underlying data concerns.

The requirements for this new process were fairly straightforward. It must be able to handle any task-organized force (based upon the capabilities desired), include the entire US force structure inventory (as contrasted to just the major combat organizations), be able to show the current and future operational availability, and have the data organized and accessible within the joint community. Simultaneously, the joint community also wanted to be able to track forces once they

---

<sup>4</sup> OEF: Operation Enduring Freedom; OIF: Operation Iraqi Freedom.

were deployed, accounting for both the location of these forces and the “activities/events” these forces were performing.

As the J-8 worked on the Assignment, Allocation, and Apportionment process, the first problem was to identify what data exists to facilitate answering these questions. The initial data store used was the data collected for the Force Structure Screening Tool (FSST). Three major problems were discovered when attempting to use the FSST for real operational/actual data:

- Data latency. Although the data may have been available, it was not kept current.
- Level of Detail. Most of the data collected only went to the Unit Identification Code (UIC) level of detail. The current deployment schedule demanded a level of detail well below that of UIC.
- Lack of a Standard Terminology. Each of the Services presented their data differently. For example, when comparing a USMC battalion to a US Army battalion, there were no common representations between the two elements. Common factors that everyone understood had to be developed, so that one could compare the two units (e.g., “boots on the ground” to account for the number of people that were actually deployed/deploying).

The problem that had to be solved was the collection of information necessary to make an informed decision for the future OIF/OEF rotations. It was decided, at the very highest levels, to use the venerable “brute force” method to create the global force laydown for OIF/OEF.

- Information requirements were developed for an Excel spreadsheet called the “Global Force Laydown” (GFL).
- The real “operational” data, as reported by the Services, was the initial source for populating the GFL. This operational data was used to populate some, but not all, of the data requirements for the GFL.
- A special data call went to the Services requesting an update to this information for all major combat units. Notice that “major combat units” specifically excludes all CS and CSS units that are considered later in the process. A standardized format (in an Excel spreadsheet) was provided. A month was required to receive this information and consolidate it into a single list. Recently, this data request was sent to Joint Forces Command rather than directly to the Services.
- Once the list was completed, it went to the Service planners to verify that the information was still accurate. All Services continued to change, refine, or update the information, basically stating that changes to the operational status were not reflected in the “operational” data. Even after this refinement, it took weeks to derive what really “was” the current operational laydown (as of the beginning of the month).
- The data was “correct,” but a month out of date. Decisions were made based on this information. After the decisions were finalized for the Combat units, CS and CSS requirements were defined and sourced under a separate process.
- The entire process took approximately five months and several thousand man-hours to complete. A month after completion, the entire process was restarted for the next rotation cycle.

Another major problem was conflicting data requests that asked for the same “type” of information, but with a slightly different flavor or format. Several requests for information could be made by different offices within the Joint Staff Directorate or within the Joint Staff itself, each asking for the data in a slightly different way.

Adding to these problems was the fact the data changed on a daily basis. There was simply no way to keep the data accurate, current and be able to use it in the decision making process. Compounding these problems was the need for High Density, Low Demand (HDL) specialties (e.g., dog handling teams, prison guards, etc.) that needed to be manipulated at the individual level rather than at the UIC level of detail.

In May 2003, the *Department of Defense Net-Centric Data Strategy* (NCDS) was released to address the new capabilities created by the Internet and Web Services. The intent of the NCDS is to outline the vision for managing data within DoD. The key attributes of the strategy are:

- Ensuring data are visible, available and useable when needed and where needed to accelerate decision making.
- “Tagging” of all data (intelligence, non-intelligence, raw, and processed) with metadata to enable discovery of data by users.
- Posting of all data to shared spaces to provide access to all users except when limited by security, policy, or regulation.
- Advancing the Department from defining interoperability through point-to-point interfaces to enabling the “many-to-many” exchanges typical of a net-centric data environment.

The Strategy also introduces management of data within communities of interest (COIs) rather than standardized data elements across the Department. COI is the inclusive term used to describe collaborative groups of users who must exchange information in pursuit of their shared goals, interests, missions, or business processes and who therefore must have shared vocabulary for the information they exchange, including any external authorized, but unanticipated users.<sup>5</sup> With the advent of the NCDS, it was decided to try using a COI to solve the GFM data problems.

## **2. The GFM DI’s Scope Is Enterprise Wide, Making It A Special Challenge For A COI**

In 2003, the Force Structure, Resources, and Assessment Directorate (J-8) of the Joint Staff, sought resolution of these force management issues. The desire to address this issue began with discussing the problem with all of the potential (high-level) stakeholders and gaining their perspectives. Although the primary impetus for creating the GFM COI was the governance and maintenance of force structure data, it soon became apparent that the lack of consistent force structure data affected every major area within DoD. Although everything in DoD relates to force structure, no single authoritative data source exists.

---

<sup>5</sup> From the Department of Defense Net-Centric Data Strategy, 9 May 2003;  
See: <http://www.defenselink.mil/nii/org/cio/doc/Net-Centric-Data-Strategy-2003-05-092.pdf>

The “G” in GFM DI is real. Force structure data is pervasive across the systems that comprise the DoD enterprise, and all the stakeholders quickly recognized this. GFM force structure data was needed for:

- The Defense Integrated Military Human Resources Systems (DIMHRS)
- The Global Directory Services
- The Defense Readiness Reporting System
- Tying resources to capabilities and capabilities to force structure
- Unique Item Identification (UID)
- Command and Control systems
- And a host of other automation systems.

As is indicated by this list, much of the “GFM Domain” (per NCDS vernacular) intersects a large percentage of DoD data systems, thus making the task of the GFM COI an enterprise-wide task which is an anomaly per the intent of COIs in the NCES data strategy:

Communities provide an organization and maintenance construct for data such that their data goals are realized. Moving these responsibilities to a COI level reduces the coordination effort as compared to managing every data element Department-wide.<sup>6</sup>

As a result, the GFM COI is being used to address problems that cross the Business Management Modernization Program (BMMP) data domains, whose boundaries are already ambiguous. This was not an insignificant problem. The J-8 recognized that an unprecedented level of collaboration would have to be met to achieve a truly transformational evolution of data within the Department. With the publishing of the NCDS, he now had a vehicle to address the force management issue.

To achieve high-level buy-in, the J-8 looked to several authoritative decision making bodies to adopt and accept a force structure construct that would transform how the Department will use data in the future. The first step was to brief the force structure construct to the Senior Readiness Oversight Council (SROC<sup>7</sup>). The SROC directed that:

The Joint Staff, in coordination with USD (P&R), will structure the implementation of enterprise-wide unit identifiers. This initiative shall be consistent with Net-Centric Data Strategy, preclude redundancy with other identifiers efforts, and synchronize roadmaps for ongoing force management initiatives. USD (P&R) will draft a DoD Directive that formalizes implementation of organizational force structure identifiers across the Department.<sup>8</sup>

Accomplishing this intent across DoD resulted in Strategic Planning Guidance (SPG) language creating the Global Force Management Data Initiative (GFM DI).

---

<sup>6</sup> Ibid.

<sup>7</sup> The SROC is comprised of the DepSecDef, OSD Primary staff members, Service Secretaries and Chiefs and the Commandant of the Marine Corps.

<sup>8</sup> Memorandum dated 20 Jan 2004, from Deputy Secretary of Defense, Subject: Actions from the Senior Readiness Oversight Council of December 10, 2003

To support Global Force Management, the CJCS will develop, by 31 October 2004, a joint hierarchical way to organize force structure data for integration across Service lines. The Service Secretaries, Combatant Commanders, D(DISA), CJCS, USD(P&R), and JPEC will identify and develop common standards and parameters for data semantics, sources, timeliness, accuracy, collection, and recording methods specific to force management.<sup>9</sup>

To keep the momentum going and to ensure funding would be applied to the GFM DI, the Initiative became an Enhanced Planning Process (EPP) Issue. As an EPP Issue, the GFM DI was briefed several times to Service 3-Star Programmers. Once all the Service Programmers accepted the concept, Joint Programming Guidance (JPG) language was written that provided the funding necessary for the GFM DI. The JPG directed:

Global Force Management: Joint Staff, Air Force, Navy, Marine Corps add money during FY 2006-2011 from within existing resources for development of standardized force structure data that will provide on-demand information in a net-centric environment.<sup>10</sup>

### **3. COI Representatives Fluctuate As The Solution Evolves**

As mentioned previously, the “G” in “GFM” really does mean it is global. GFM DI crosses each of the BMMP mission areas and domains. Selecting the “right” COI membership was going to be a problem, as the focus of the COI would change over time. One should not expect COI membership to be static.

The initial set of members included representatives from the Military Services,<sup>11</sup> members of the OSD primary staff, the Defense Agencies, USSOCOM, and JFCOM. The initial problem set clearly rested in the Force Management area, but the initial representatives did not necessarily represent these communities within their proponents. After a few adjustments the right representatives were attending the meetings.

COI meetings were initially held every week. The main thrust of these meetings was to get the right people there and then educate them to the problem, all the while keeping them very narrowly focused on the problem set that they had to address – namely making the “authoritative” force structure data available in a net-environment. As part of the education process, each of the members presented their perspectives on force management, in an attempt to reach a common perspective for the Department.

Workshops were held between regular COI meetings to identify and cover technical issues. In these workshops, the COI representatives normally changed from the “policy” force management people to the “functional” people with specific skills and expertise. This increased collaboration, requiring more horizontal integration within the Department, was a necessary, although painfully slow, step. Significant coordination efforts to ensure that the correct representatives attended the “right” meetings were essential to maintain the progress of the COI.

---

<sup>9</sup> Strategic Planning Guidance Fiscal Years 2006-2011, 15 Mar 2004, page 30-31

<sup>10</sup> Joint Planning Guidance Fiscal Year 2006-2011, 9 Jun 2004, page 3

<sup>11</sup> Including the Coast Guard.



An intellectually difficult task of a COI is determining the common set of semantics. Once the group agrees on what something means, the entire process runs smoother. For example, if one hears the term “squadron,” a certain type of unit comes to mind. Depending on your experiences, one may be thinking of a destroyer squadron, an F-16 squadron, or a cavalry squadron. Each of the proponents will contend that their definition of a squadron is the “correct” one - and it is, for them. But until a common understanding is reached that all of these terms are types of “units,” progress cannot continue.

Each of the Services does force management differently and rightfully so, as they perform different functions within the Department. But, even inside of the Services (supposedly “common”), many differences and inconsistencies exist. The only thing that each of the Services really have in common is that they all require flexibility to support the warfighter. Guiding the COI to a common solution set, which by definition is not the way business is currently done, is challenging and time consuming.

Because force structure is represented in some way, shape, or fashion in every domain, the GFM COI *requires* membership that spans every domain. The COI representatives must have the ability to span the complexity of the solution set, going from high-level policy (and the impacts upon the Department), to the minor, annoying technical details (which are required to make the solutions work.) Not only is understanding the topics at several different levels required, but one must also have meaningful, “implementable” agreements. This is due to the fact that the Services must provide the majority of this data.

Over time, the frequency of the COI meetings has diminished, primarily because the “education” phase takes significant time up-front. This was followed by the “problem definition” and “initial solution set” phases. The GFM COI is now in the “put real data in and test it” phase. The interesting observation of the COI membership is that as time goes on, attendance of the COI has grown to “standing room only.” COI meetings are currently held once a month, with a robust information package sent to the membership, as the situation warrants.

#### **4. Vision Without Funding Is Hallucination – the COI-EPP Interaction**

The GFM DI is recognized as being foundational for the transforming DoD. It has received tremendous momentum by being designated as both an SPG Issue and one of only eleven EPP Issues. But the bottom line is that a vision without funding is hallucination. Regardless of the top-level interest, without funding this initiative would die since no one likes change and everyone resists new, unfunded requirements.

To ensure that it would be pushed forward throughout the DoD budgeting process, an EPP Issue Team was established in parallel to the COI to ensure that the results of the COI were funded for implementation. Using the Service points of contacts and other key members of the GFM COI as its members, the EPP Issue Team was tasked to develop and examine the funding needed for the development of standardized force structure data that will provide on-demand information in a net-centric environment. The EPP Issue Team did just that, but no new funding was available unless offsets were provided. Most of the details were worked out within the context of the COI, and the EPP Issue Team briefed the results to the Service 3-Star programmers. The Service

programmers agreed to add money during FY 2006-2011 from within existing resources for development of standardized force structure data, thus driving the JPG language.

## 5. A COI Requires a Set of Guiding Principles and Tenets

It was known early in this process that the GFM COI would drive new policies needed to address the integration to achieve the desired effects across the DoD. But knowing that policies need to be written and figuring out what to write are two entirely different processes.

The initial solution set began with a marriage of past force structure construct research,<sup>12</sup> the NCDS, and the Command and Control Information Exchange Data Model (C2IEDM), now known as the Joint Consultation, Command and Control Information Exchange Data Model (JC3IEDM). The JC3IEDM is a collaborative effort between the Multilateral Interoperability Program (MIP)<sup>13</sup> and the NATO Data Administration Group (NDAG); and it provides a set of information elements, entities, and relations that describes the information exchange requirements within tactical military operations. This solution set is now known as the GFM “Force Structure Construct” (FSC)<sup>14</sup>, and is described in DoD Directive 8260.3 (Draft, distribution pending approval).

The GFM FSC provides the framework and the foundation to link authorization data together with the actual organizations, equipment, and personnel, as well as other associated resource, readiness, and capability information needed to answer the GFM DI questions. This will provide DoD Components the ability to use the organization structure for reporting data to meet real-time, future, and unanticipated requirements in a joint environment. The FSC, as developed by the GFM COI, will be used to represent all organizational structures, both administrative and combatant, within DoD. The FSC consists of three major elements: documenting, identifying, and disseminating.

Documenting the authorized force structure in an authoritative data source using the Global Force Management Information Exchange Data Model (GFMIEDM) format is the first element. The GFMIEDM, an augmented subset of the JC3IEDM, is a reference model that can be used to exchange information between two systems to reach a common understanding of the data. The GFMIEDM contains the minimum essential set of data elements that the GFM COI has determined needs to be exchanged. Documenting the force structure includes:

- Defining the comprehensive, hierarchal, default force structure for use by all systems within the DoD enterprise.

---

<sup>12</sup> Chamberlain, S., *Default Operational Representations of Military Organizations for Joint and Coalition Operations*, 1999 Command & Control Research & Technology Symposium, Naval War College, Newport, RI; 29 Jun-1 Jul 1999; see: [http://www.dodccrp.org/events/1999/1999CCRTS/pdf\\_files/track\\_5/056chamb.pdf](http://www.dodccrp.org/events/1999/1999CCRTS/pdf_files/track_5/056chamb.pdf).

<sup>13</sup> See: <http://www.mip-site.org>.

<sup>14</sup> Chamberlain, S. and Sprung, G. *A Unifying Strategy for Data Integration for Global Force Management*, 9th International Command and Control Research and Technology Symposium, Copenhagen, Denmark, 14-16 Sep 2004; See: [http://www.dodccrp.org/events/2004/CCRTS\\_San\\_Diego/CD/track02.htm](http://www.dodccrp.org/events/2004/CCRTS_San_Diego/CD/track02.htm).

- Presenting this force structure data in a “top-to-bottom” hierarchical structure, down to the billet level, and including both the operational (doctrine, tactics, techniques, and procedures) and administrative (i.e., functional representations) aspects.
- Controlling and operating an “organization server.” An organization server is the single authoritative data source for the authorized force structure. It is a web-enabled database containing default operational organizations available via the GFMIEDM format.
- The entire authorized force, to include active, guard, reserve, and civilian forces will be represented in the organization servers.
- The GFMIEDM is used to provide common semantics and rules for documentation.

Uniquely identifying each force structure element in the GFMIEDM across the GIG is the second element. All force structure data within the GFMIEDM is uniquely tagged with Force Management Identifiers (FMIDS). This unique identification provides the DoD components the ability to manage and have greater visibility for any war fighting or administrative structure, from an individual to a joint task force for a Combatant Command. It allows data to be easily associated and linked to meet real-time and unanticipated requirements.

All force structure data (organizations, manpower and equipment authorizations) within the organization servers are tagged and permanently associated with the data it identifies. The intent is to share this data within and across the Warfighting, Business, and Intelligence Mission Areas, including administrative and operational, permanent and temporary data items.

The FMIDS data tag will be retained by the systems that use force structure data and will be assigned to all existing and future GFM process data that will be shared across the Mission Areas. Inherent in the FMIDS design is its ability to enable data sharing throughout DoD, with consideration for tactical-level communication systems.

Disseminating the force structure information in a net-centric environment is the third element. In addition to uniquely identifying force structure data, each organization server, regardless of the U.S.C. Title Authority, uses the same Extensible Markup Language (XML) schema. The use of FMIDS in the XML will be detailed in the DoD Instructions for the GFM FSC. The GFMIEDM XML has one consistent schema, as approved by the GFM COI. Net-centric tools will provide the functionality, and FMIDS will provide the means to link and integrate data.

## **6. Development of a Prototype Is Instrumental to the GFM COI**

One cannot overstate the importance of developing a prototype. Many concepts appear clear in the generic, but as soon as details are introduced, contradictions seem to arise, and suddenly basic assumptions come under question and require clearer definitions. The modeling process epitomizes this problem.

Recall that the objective for GFM DI is to establish a transparent and universal process to manage, assess, and display the world-wide disposition of US forces, including availability, readiness, and capability, that enables insight into global availability of US forces. To have this insight, it is first necessary to have the force structure (organizational hierarchy) data that can support all of the automation systems and have the flexibility to adapt for any operational warfighting use. To

enable this, GFM DI uses the “authorized” force structure as the central integrating theme for the DoD. Using the GFM FSC and implementing it via the GFMIEDM requires that three tasks must be accomplished:

- The authorized force structure must be formally documented electronically for easy manipulation within a computer. This requires the development and implementation of joint, hierarchical force structure data for integration across Service lines. It is also necessary to rigorously and unambiguously specify the semantics and formats so that sophisticated computer programs can economically exploit it.
- Each piece of force structure data must be uniquely identified for computer usage.
- The data must be capable of dissemination in accordance with the DoD Net-centric Data Strategy, with a minimal amount of translation required by any end-users that requires the data.

It is important to remember that the primary goal of the COI was the creation of a process to create reliable and maintainable data. Defining how the organization servers would be populated with authorization data was selected as first priority. A set of prototype organization servers are being developed that contain a typical operational slice (task organized force) from each of the Services. This will clarify the vision of organization servers, assist in the evaluation of the underlying force structure concept, and identify subtle problem areas. Working with the Services, the following four operational slices were selected:

- An Expeditionary Strike Group (ESG) of the US Navy,
- A Marine Expeditionary Unit (MEU) of the USMC,
- A Brigade Combat Team (BCT) of the US Army, and
- A Provisional Wing of the USAF.

The development of these slices provides a forum to interact with each Service to identify concrete issues of a detailed nature. This, in turn, provides precise examples for evaluation and comparison that may impact the development of general principles applicable across the Services.

Recall that an organization server contains default authorization data with the intent that, when populated carefully, it will provide a set of default organizations, down to the billet level, that serve as building blocks for the creation of arbitrary orders of battle. It may appear ironic (or confusing) that operational slices are selected for demonstration, when what is actually being created is the default subset of the Service Organization Server required to build the operational slice. However, this is exactly how the concept is implemented. The operational slices are task-organized forces created *from* the force structure data within the Service Organization Servers. The selection of the operational slice allows the minimal subset of default organizations to be identified, thus making the task of building a prototype tractable.<sup>15</sup> In addition, a portion of the “top” few echelons of the Services are created to provide a continuous default structure down to

---

<sup>15</sup> This approach was selected because the alternative would have been to build the entire Service structure, which was far beyond the capability of the COI.

the subordinate organizations being used for the operational slice. Thus, the top node in each of the Service Organization Servers is their department (e.g., Department of the Air Force).

A detailed discussion of the second task, unique identification, is not included in this paper because it has been described in detail in past Command & Control Research & Technology Symposium papers.<sup>16</sup> Current plans are to use a common identification scheme, the set of which are called FMIDS, that implement the data type and procedures described in the referenced paper. This data type is currently named an Enterprise-wide Identifier (EwID) and is a 64-bit non-intelligent number. Ultimately, as bandwidth becomes available at the lowest (fighting) echelons, existing FMIDS will be converted to Version 3 (name based) UUIDs (Universally Unique Identifier),<sup>17</sup> while new FMIDS can be created using any of the UUID types.

The third task, dissemination, requires that an interface specification be developed. There are many ways to accomplish this task, and all require that significant time and intellectual effort be expended to carefully and rigorously define the required properties and semantics of the data. Two criteria agreed to by the COI were: one, to take full advantage of the plethora of work already done in this area, and two, to try to address Allied interoperability in concert with its joint counterpart. This second criterion was based in part on the concept that joint and Service battle command requirements are actually super sets of the multinational core requirements.<sup>18</sup> For these reasons, an information exchange data model (IEDM) developed under the MIP was chosen as the starting point for the GFM DI interface specification. IEDM's are one method for defining information exchange specifications and offer extensive features for defining detailed semantics. More important, the MIP JC3IEDM has been under development for years and has been adopted and implemented in several NATO battle command systems.

As stated previously, the GFMIEDM is an augmented subset of the JC3IEDM. Whenever possible, the JC3IEDM values are used. A major tenet is to keep the specification to a minimal size. To date, the GFMIEDM contains 46 entities of which 7 are new, most notably to support manpower authorization requirements. When new items are added, care is taken not to duplicate JC3IEDM resources and to consider how the new values would be mapped into the JC3IEDM attributes.

COIs and XML are no panacea. Even though discovery mechanisms and meta-data tags are included via the NCDS, there are still a myriad of opportunities to create and interpret force structure data in many different contexts. Perhaps this is the most difficult challenge of the COI: to develop a force structure construct rigorous enough so that applications can share data and interpret the resulting information uniformly. Without a prototype to expose subtle differences, this task could not be accomplished. Terms like "assign," "attach," and "operational control" have English definitions, but when one begins to explore their use across the Services and echelons, ambiguities arise that can be surprising. These definitions must be clearly defined by the COI membership.

---

<sup>16</sup> See: *Implementation of an Enterprise Identifier Seed Server for Joint and Coalition Systems*, 7<sup>th</sup> ICCRTS at [http://www.dodccrp.org/html/events\\_0102.html](http://www.dodccrp.org/html/events_0102.html) or <http://www.arl.army.mil/~wildman/PAPERS/7thc2rt.html>.

<sup>17</sup> UUID: From the ISO-11578 (Remote Procedure Call, RPC) standard that is based upon The Open Group Distributed Computing Environment (DCE) RPC standard.

<sup>18</sup> See CCRP Paper *Multinational Interoperability Requirements – A Core Competency* from the 5<sup>th</sup> ICCRTS, [http://www.dodccrp.org/events/2000/5th\\_ICCRTS/cd/papers/Track3/010.pdf](http://www.dodccrp.org/events/2000/5th_ICCRTS/cd/papers/Track3/010.pdf).

The Service Organization Server interfaces may provide as many features (e.g., web services) as desired by their maintainers, but the minimum requirement is to be able to delivery organization server data in an XMLized GFMIEDM format. It is important to understand that the GFMIEDM is an information exchange standard and does not dictate how the data is physically stored within an organization server. The internal design of the organization server is left to the discretion of the owners. However, this does not detract from the rigor required in the design, implementation, and adherence to the GFMIEDM.

## 7. Summary

This paper described a few of the challenges and discoveries associated with the establishment of a Community of Interest to provide solutions to information problems associated with the Global Force Management Data Initiative task. The GFM COI has evolved considerably since its inception on 11 July 2003. Not surprisingly, a COI is no panacea; and it does not displace the difficult task and extensive intellectual efforts required to establish agreements among diverse users of data, even when the data set is restricted. Reflecting back on its short history, the realization of several prominent characteristics seems to have facilitated moderate success to date.

a. *A Community of Interest (COI) Should Be Created To Solve A Problem.* The GFM COI was established to address a real, concrete problem. This may appear to be an obvious criterion, but it is tempting to establish a COI for a general domain or problem area without identifying a particular problem on which to work. Throughout its existence, a significant portion of the effort of the COI has been the continual development and refinement of a rigorous definition of the GFM DI problem.

b. *The GFM DI's Scope Is Enterprise Wide, Making It A Special Challenge For A COI.* The GFM DI realm, or more specifically, organization and force structure information, crosses every mission area and domain in the DoD. A primary purpose stated for creating COIs, per the NCDS, is that, "Moving these responsibilities to a COI level reduces the coordination effort as compared to managing every data element Department-wide." Unfortunately, by its nature, the majority of data associated with the GFM realm is inherently Department-wide, thus the COI concept did not attenuate this challenge. However, by continually defining the GFM domain, the COI is able to restrict the focus of the group to major issues, thus reducing distractions from less immediate problems. Because of the enterprise-wide nature of the GFM DI objectives, significant assistance and participation from senior DoD leadership was sought and obtained. The Joint Staff Director, J-8 and his senior staff continue to be major participants in securing cooperation from and establishing policy with the Services, Joint Staff, and other DoD agencies. Simply stated, the success of this COI is dependent on the participation of the Services. Without the emphasis placed by senior leadership, the GFM COI would not have achieved the successes it has.

c. *COI Representatives Fluctuate As The Solution Evolves.* COI membership requirements fluctuate with the problem set or phase being addressed. One should not expect to have a static set of COI representatives. Although an attempt is made to maintain a stable group of leaders from the participating agencies, one of the most challenging tasks is to bring the right set of experts together as the meetings are assembled. This means that meeting agendas have to be carefully considered and published well in advance, with specific topics prepared and exit criteria defined. One of the most time consuming facets of a COI is educating its membership. Consequently,

there is a constant effort to achieve a balance between maintaining a stable membership and acquiring the right expertise. To be successful, significant time must be allocated to educating new and transient members.

d. *Vision Without Funding Is Hallucination.* The dedication and hard work of a COI membership will only lead to success if funding is provided to implement its results. For this reason, the COI leadership also participated in the Enhanced Planning Process to ensure that the Services were funded when required. This included both securing “seed” funding for the initiation of the Service organization servers and ensuring that the Services budgeted for their care and maintenance in future years.

e. *A COI Requires a Set of Guiding Principles and Tenets.* It is essential to specify a set of principles and tenets to guide the COI data development process. For example, the primary goal of the GFM COI is not merely the specification of data and services, but the actual creation and maintenance of the data in an unambiguous form. Paramount to this objective is the identification and sanctioning of authoritative data sources. No other task of the COI has been more challenging than this one, particularly because it is not one of time obligation, but requires a continuing commitment to provide highly detailed, quality data to the DoD, and ultimately, to our Allied partners. Further, the principles must apply to both technical strategies and policies so that informed decisions can be made to compromise when necessary, but still maintain enough constraints to ensure the solutions converge to a workable and interoperable end state.

f. *Development of a Prototype Is Instrumental.* To evaluate the principles, policies, and technical strategies accepted by the GFM COI, the development of a prototype remains instrumental in producing a realistic, workable, and minimal solution to a very difficult set of criteria. The importance of the GFM DI cannot be overstated. Actual force structure slices of the four Services are being created to identify problems and ambiguities in the data and operational definitions that could otherwise easily go undiscovered. The results of the prototype provide concrete examples that make it possible for the COI members to assimilate the general problems and provide explicit solutions to subtly difficult concepts that have been taken for granted for years because they have been hidden within their English definitions. It is a difficult task to create rigorous and formal definitions of military operational concepts so that they can be “understood” by computer algorithms. Perhaps this daunting task was best reiterated by Gen Bruce C. Clarke who often repeated a statement by one of his English professors: “If you're going to be successful in the military where you have to issue instructions and orders, you must have the ability to issue them, not just to be understood, but so you can't be misunderstood.”<sup>19</sup>

---

<sup>19</sup> See: <http://www.trumanlibrary.org/oralhist/clarkeb.htm>.



# *Establishing a Community of Interest (COI) for Global Force Management*

**Sam Chamberlain, Ph.D.** US Army Research Laboratory; (410) 278-8948 // DSN 298  
[chambesc@js.pentagon.mil](mailto:chambesc@js.pentagon.mil), or [sam.chamberlain@us.army.mil](mailto:sam.chamberlain@us.army.mil)  
<http://www.arl.army.mil/~wildman>

**Mike Boller**  
Science Applications International Corporation,  
In Support of The Joint Staff / J-8 / MASO;  
(703) 614-6772; [michael.boller@js.pentagon.mil](mailto:michael.boller@js.pentagon.mil)

**George Sprung**  
Chief, Model and Analysis Support Office, The Joint Staff / J-8  
8000 Joint Staff Pentagon, Washington, DC 20318-8000  
(703) 693-4605, [george.sprung@js.pentagon.mil](mailto:george.sprung@js.pentagon.mil)

**Vic Badami, LTC, USA**  
Deputy, Model and Analysis Support Office, The Joint Staff / J-8  
(703) 693-2552, [victor.badami@js.pentagon.mil](mailto:victor.badami@js.pentagon.mil)

**10<sup>th</sup> ICCRTS, McLean, VA - 15 June 2005**



- 
- a. A Community of Interest (COI) Should Be Created To Solve A Problem.***
  - b. The Global Force Management Data Initiative's (GFM DI) Scope Is Enterprise Wide, Making It A Special Challenge For A COI.***
  - c. COI Representatives Fluctuate As The Solution Evolves***
  - d. Vision Without Funding Is Hallucination***
  - e. A COI Requires a Set of Guiding Principles and Tenets***
  - f. Development of a Prototype Is Instrumental***

# A Community of Interest (COI) Should Be Created To Solve A Problem

## Today's Processes

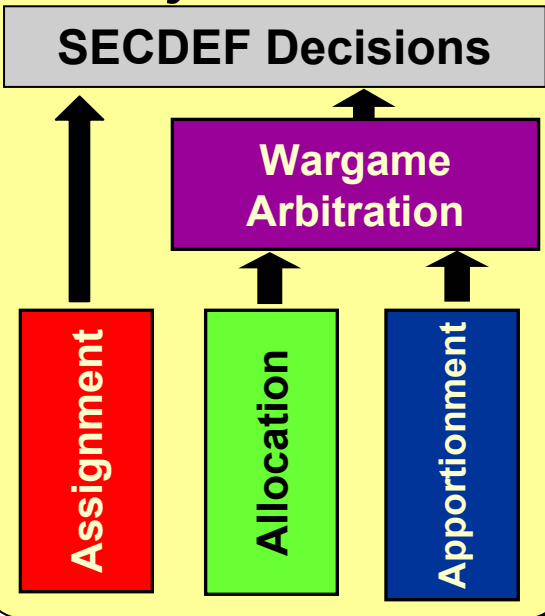

Process is not integrated

Data is not visible,  
accessible or usable



## GFM Data Needs

- Force Structure Data
  - Current Unit Locations
  - “Event” data
  - Operational Availability
  - Total US Inventory
  - Joint hierarchically organized
- Historical archive
- Timely, reliable, and authoritative

## Directives

1. Per SecDef's Memo, JS to integrate assignment, allocation and apportionment processes
2. Per SROC Guidance, the JS will implement enterprise-wide unit identifiers
3. Per SPG FY06-11, CJCS to develop/organize force structure data across Service lines
4. Per JPG DepSecDef Memo, USN, USAF, USMC add \$ during FY 2006-2011 for development of standardized force structure data to provide on-demand information in a net-centric environment

# The GFM DI's Scope Is Enterprise Wide, Making It A Special Challenge For A COI

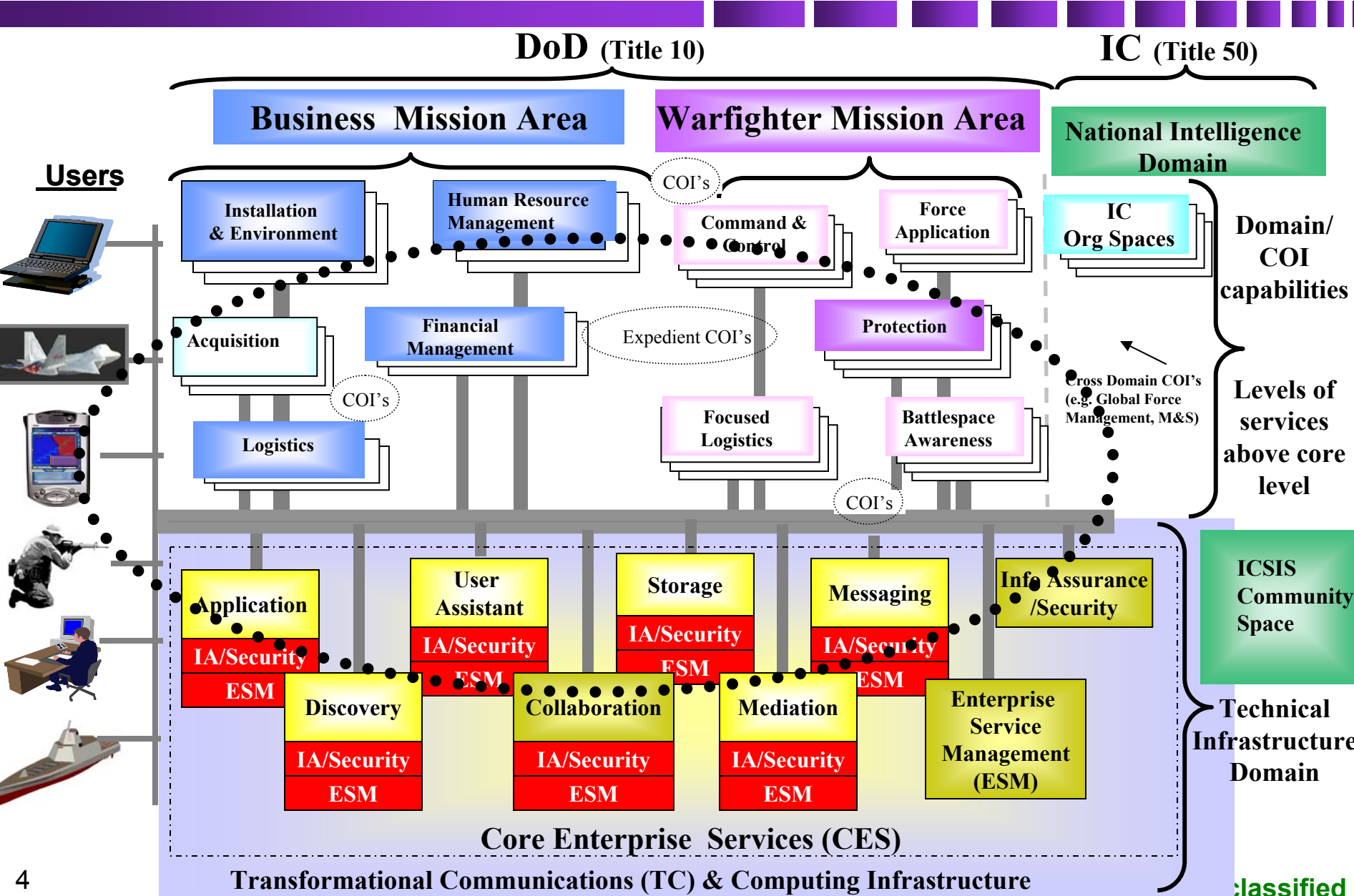

# COI Representatives Fluctuate As The Solution Evolves

## Personnel/Manpower



## Resources



## Materiel



## Plans/Readiness



## Capabilities

Orders      C2      +  
 Objectives      Targeting      +

**Uses Force Structure (FS) to integrate data**

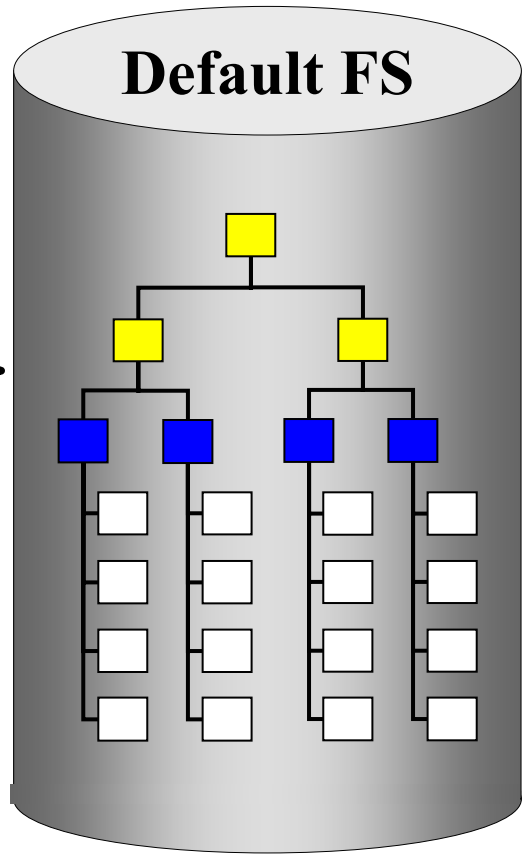

- **Hardcore computer science problem**
  - No “silver bullet”
  - Must create the data
- **Must document all organizations**
  - Administrative
  - Combatant
  - Operational
  - Rigorously reported
  - Starting point for any joint task organization
- **Common identification (XML & FMIDS)**
- **Disseminate from a single authoritative data source**

## *Vision Without Funding Is Hallucination (GFM EPP Tasks)*

- **Task 1**: Joint Staff, J-8 identifies required GFM data elements (unit, location, event, ...) to include Defense readiness Reporting System (DRRS) data elements NLT 2 Feb 04
- **Task 2**: Components identify all GFM authoritative sources (databases) to match the data model resulting from Task 1 NLT 17 Feb 04
- **Task 3**: Components will identify and develop roadmaps on when these GFM authoritative sources will be created and web-service-enabled NLT 1 Mar 04
- **Task 4**: Joint Staff and GFM Enhanced Planning Process (EPP) Issue Team will evaluate the roadmaps to web-service-enabled GFM authoritative sources to achieve desired capabilities NLT 1 Apr 04
- **Task 5**: Joint Staff and GFM EPP Issue Team develop draft Joint Programming Guidance (JPG) language NLT 15 Apr 04
- **Task 6**: Components review draft JPG language NLT 1 May 04

# A COI Requires a Set of Guiding Principles and Tenets

## Document

A hierarchical way to organize (document) force structure data for integration across Service-lines

- Top to bottom (billet level) organizations with operational organizational aspects (Tactics, Techniques, and Procedures)
- The **GFMIEDM** provides common semantics and rules
- Documented in an single authoritative data source call the **Organizational Server**.

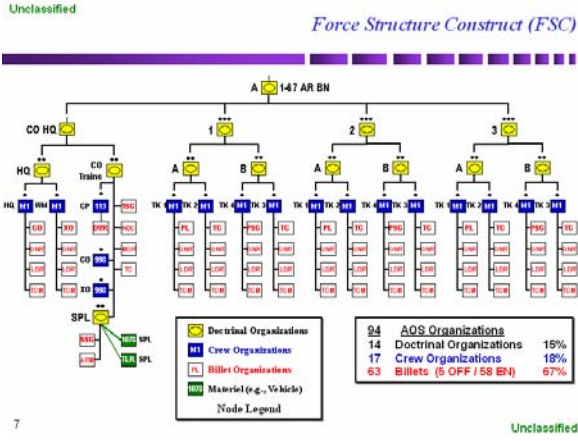

## Identify

- XML tagging for web services (e.g., discovery, collaboration, mediation, etc.)

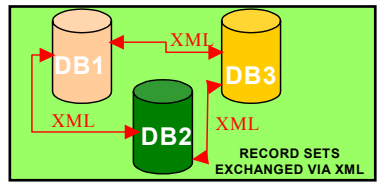

- FMIDS (unique data identifiers) to allow data integration

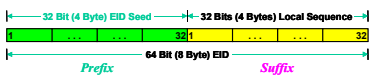

## Disseminate

- Org Servers are the Authoritative Data Source
- Web-service-enabled

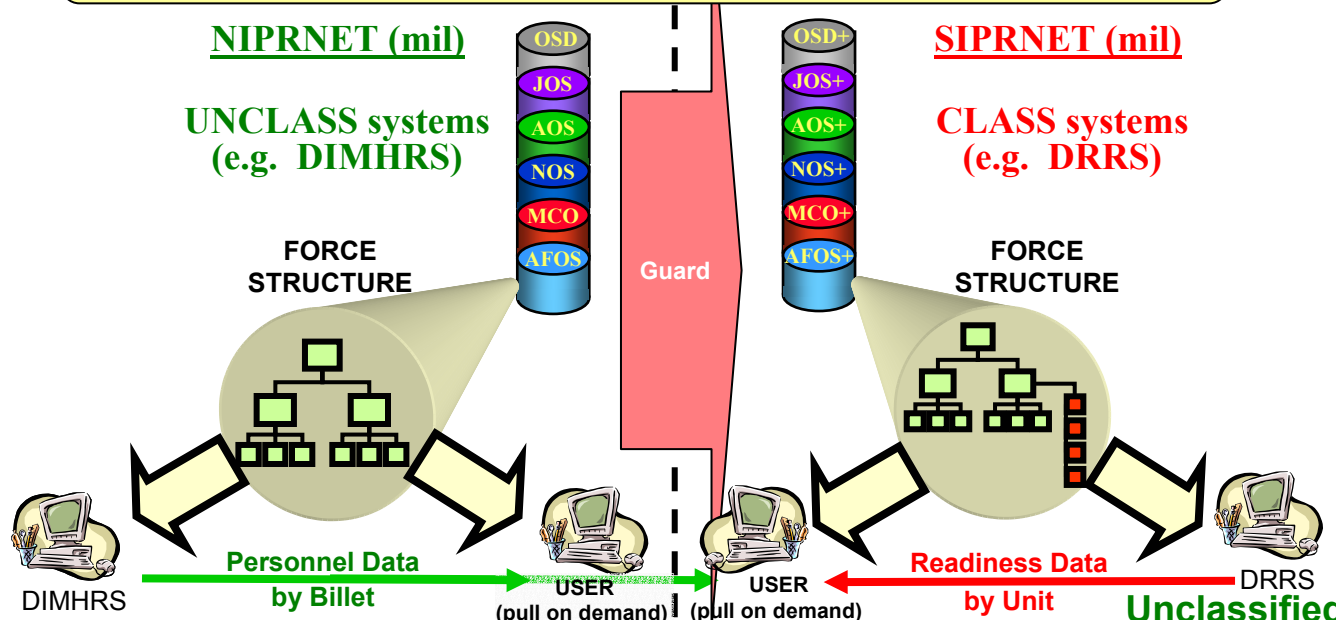

## *Development of a Prototype Is Instrumental [1]*

- **Preparing a “Combat Slice” from each of the Services and putting it into GFMIEDM format**
  - Navy – 2<sup>nd</sup> Expeditionary Strike Group (ESG)
  - USMC – 26<sup>th</sup> Marine Expeditionary Unit (MEU)
  - Army – 1<sup>st</sup> Brigade Combat Team, 1<sup>st</sup> Cavalry Division
  - Air Force – 4404<sup>th</sup> Wing (Provisional) - AEW
- **Simultaneously preparing the Concept of the Operations (CONOPS) in three areas:**
  - Organization Server Operations
  - Allocation, Assignment & Apportionment process
  - GFM in a net-centric environment

***Objectives: Define business rules, flush out GFMIEDM, and demonstrate capabilities of GFM DI prototype***

# Development of a Prototype Is Instrumental [2]

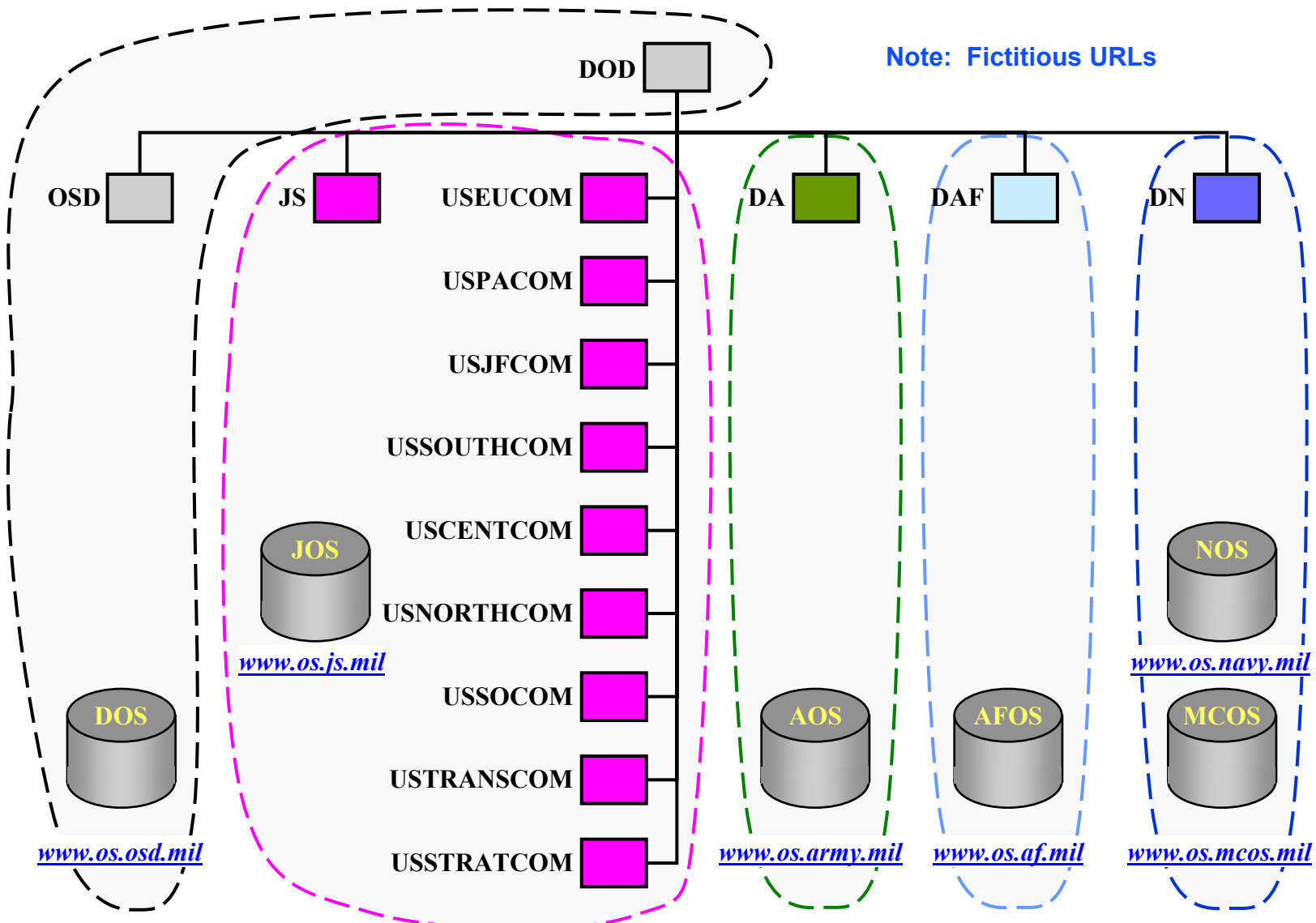



# Development of a Prototype Is Instrumental [3]

Organization Chart Demo (build 49): dtrp9cavfinalchart3 @ 2005-05-09 Mike = 01000244

File Settings Find Print Tools Show Help

Org Type Tree Organization Tree

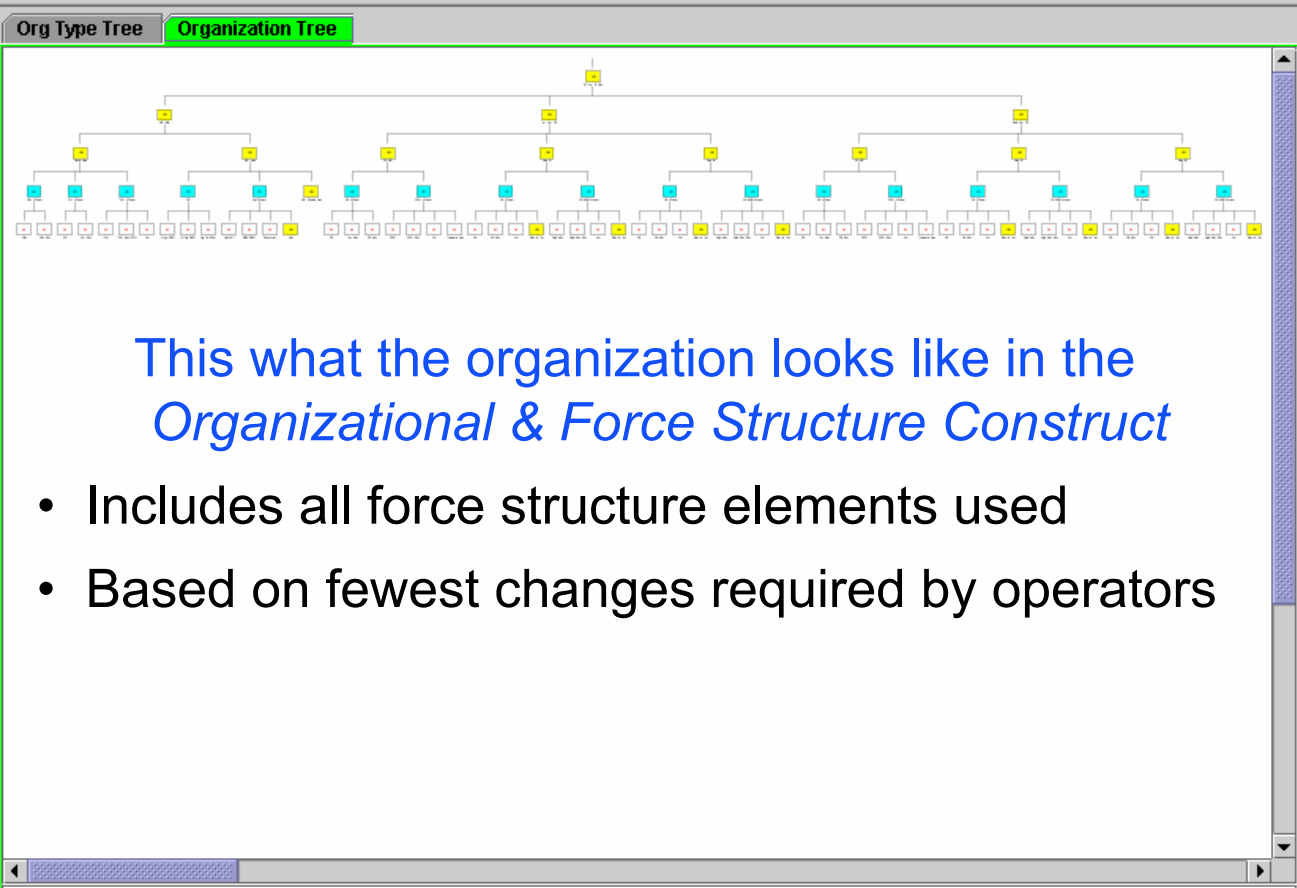

This what the organization looks like in the *Organizational & Force Structure Construct*

- Includes all force structure elements used
- Based on fewest changes required by operators

D Troop, 9<sup>th</sup> Cavalry in the Organizational & Force Structure Construct (OFSC)

D Troop, 9th Cavalry is the selected node.

# Development of a Prototype Is Instrumental [4]

Organization Chart Demo: dtv3chart3 @ 2005-03-28 Mike = 01000244

File Settings Find Print Show Help

Org Type Tree Organization Tree

Org Type or Organization

Materiel Type Estab

Person Type Estab

Skill Type

1<sup>st</sup> Platoon, D Troop, 9<sup>th</sup> Cavalry OFSC

First Scout Platoon is the selected node.

# Development of a Prototype Is Instrumental [5]

Organization Chart Demo: dtv3chart3 @ 2005-03-28 Mike = 01000244

File Settings Find Print Show Help

Org Type Tree **Organization Tree**

```

graph TD
    UN1[UN  
Sct Sec A] --- CR1[CR  
SL Vec]
    UN1 --- CR2[CR  
Sqd Ldr Vec]
    CR1 --- BL1[BL  
Sec Ldr]
    CR1 --- BL2[BL  
Sct Dvr]
    CR1 --- BL3[BL  
Sct]
    CR1 --- UN2[UN  
Dmtd Tm]
    CR2 --- BL4[BL  
Sqd Ldr]
    CR2 --- BL5[BL  
Sct Dvr]
    CR2 --- BL6[BL  
Sct]
    CR2 --- UN3[UN  
Dmtd Tm]
  
```

Org Type or Organization

**Matériel Type Estab**

**Person Type Estab**

**Skill Type**

Scout Section "A", 1<sup>st</sup> Platoon, D Troop, 9<sup>th</sup> Cavalry OFSC

Scout Section A is the selected node.

## Summary

- 
- a. A Community of Interest (COI) Should Be Created To Solve A Problem.***
  - b. The Global Force Management Data Initiative's (GFM DI) Scope Is Enterprise Wide, Making It A Special Challenge For A COI.***
  - c. COI Representatives Fluctuate As The Solution Evolves***
  - d. Vision Without Funding Is Hallucination***
  - e. A COI Requires a Set of Guiding Principles and Tenets***
  - f. Development of a Prototype Is Instrumental***