

# Sensor Ontology Integration for the Knowledge Management for Distributed-Tracking (KMDT) Program

Marion G. Ceruti, Code 246206 and Dwight R. Wilcox, Code 246207  
Space and Naval Warfare Systems Center, San Diego (SSC-SD)  
53560 Hull Street, San Diego, CA 92152-5001

Tel. 619 553-4068, FAX 619 553-5136, marion.ceruti@navy.mil, dwight.wilcox@navy.mil

## Abstract

This paper describes Knowledge Management for Distributed-Tracking (KMDT), which is an ongoing research and development project to explore methods to improve military functions in the battle space, such as command, control, and decision support. It features a hypothetical use-case scenario that shows how knowledge-management technologies, such as ontologies and intelligent agents, can be used to improve battle-space awareness and the decision-making process in command centers with respect to distributed tracking and threat identification of platforms. The KMDT sensor ontology is based partly on concepts described in the MIL-STD-2525B and STANAG 4420 specifications, which define symbology to represent level-one data-fusion information, such as the classification of platforms and targets in the battle space. The paper includes a discussion of ontology-integration examples of this with this symbology as it relates to fusion and tracking.

**Topics:** Autonomous agents, command and control, decision support, knowledge management, MIL-STD-2525B, modeling and simulation, ontology, sensors, STANAG 4420, symbols, tracking

## 1. Introduction

Knowledge Management for Distributed-Tracking (KMDT) is a U.S. Navy program to explore methods to implement FORCEnet, which is the Navy's operational construct and architectural framework for naval warfare in the information age [9]. FORCEnet's goal is to integrate warriors, sensors, command and control, platforms, and weapons into a networked, distributed combat force [9]. FORCEnet brings together disparate and separately developed capabilities in general, and multiple sensor types in particular. (See, for example, [23]). KMDT assembles enabling technologies to assess the information content exchanged

in the battle space and develop enhanced awareness and control in command centers through a net-based capability for Navy Command, Control, Communications, Computers, Intelligence, Surveillance, and Reconnaissance (C4ISR).

New approaches to tracking, command and control are explored using knowledge-management technologies [6] such as sensor ontologies [4] and intelligent agents [2] [5]. A goal of the KMDT program is to show that during their task execution, intelligent agents can access sensor ontology [15] to obtain information relevant to current sensor-data requirements. Analysis and Monte Carlo simulation [8] can assess information flows in the battle space and the effect of the information on target detection, tracking and the ability of sensors to align to a common frame of reference in time and in space. Not only can multiple homogeneous sensors track individual platforms, but also multiple sensor types can participate in a level-one data fusion task [22] (detection, localization, classification, and identification) coordinated by intelligent agents, thus reducing uncertainty in command and intelligence centers.

Distributed tracking is defined as determining successive locations of objects, using multiple nodes on a network to coordinate sensor measurements of targets. The information necessary for distributed tracking also contributes to target classification and identification. A method is needed to facilitate and automate distributed tracking in the battle space. A key component of this work is focused on data needed for distributed, heterogeneous level-one data fusion using Lines Of Bearing (LOBs).

Another key component of KMDT is the sensor ontology and its development method. KMDT is aimed at developing procedures and methods that will allow analysts, operators, and war fighters alike to reduce

# Report Documentation Page

*Form Approved  
OMB No. 0704-0188*

Public reporting burden for the collection of information is estimated to average 1 hour per response, including the time for reviewing instructions, searching existing data sources, gathering and maintaining the data needed, and completing and reviewing the collection of information. Send comments regarding this burden estimate or any other aspect of this collection of information, including suggestions for reducing this burden, to Washington Headquarters Services, Directorate for Information Operations and Reports, 1215 Jefferson Davis Highway, Suite 1204, Arlington VA 22202-4302. Respondents should be aware that notwithstanding any other provision of law, no person shall be subject to a penalty for failing to comply with a collection of information if it does not display a currently valid OMB control number.

1. REPORT DATE <b>JUN 2006</b>	2. REPORT TYPE	3. DATES COVERED <b>00-00-2006 to 00-00-2006</b>	
4. TITLE AND SUBTITLE <b>Sensor Ontology Integration for the Knowledge Management for Distributed-Tracking (KMDT) Program</b>		5a. CONTRACT NUMBER	
		5b. GRANT NUMBER	
		5c. PROGRAM ELEMENT NUMBER	
6. AUTHOR(S)		5d. PROJECT NUMBER	
		5e. TASK NUMBER	
		5f. WORK UNIT NUMBER	
7. PERFORMING ORGANIZATION NAME(S) AND ADDRESS(ES) <b>Space and Naval Warfare Systems Center San Diego, 53560 Hull Street, San Diego, CA, 92152-5001</b>		8. PERFORMING ORGANIZATION REPORT NUMBER	
9. SPONSORING/MONITORING AGENCY NAME(S) AND ADDRESS(ES)		10. SPONSOR/MONITOR'S ACRONYM(S)	
		11. SPONSOR/MONITOR'S REPORT NUMBER(S)	
12. DISTRIBUTION/AVAILABILITY STATEMENT <b>Approved for public release; distribution unlimited</b>			
13. SUPPLEMENTARY NOTES <b>The original document contains color images.</b>			
14. ABSTRACT			
15. SUBJECT TERMS			
16. SECURITY CLASSIFICATION OF:			17. LIMITATION OF ABSTRACT
a. REPORT <b>unclassified</b>	b. ABSTRACT <b>unclassified</b>	c. THIS PAGE <b>unclassified</b>	
			18. NUMBER OF PAGES <b>40</b>
			19a. NAME OF RESPONSIBLE PERSON

uncertainty in command and control by better organizing and using the data collected from existing sensors.

This paper is organized as follows. Section 2 describes the motivation for KMDT. Section 3 discusses the background and method. Section 4 discusses concepts found in symbology that relate to data fusion. Section 5 describes the sensor-ontology structure and component integration, including observations about the noun ontology. Section 6 discusses the verb ontology and assertions based on actions related to data sensor-fusion. Section 7 summarizes the conclusions of the paper.

## 2. Motivation for KMDT

Cross LOBs using heterogeneous sensor data and other information from multiple platforms in the battle space can reduce the uncertainty in platform detection, localization, classification and identification. Sensors deployed on a single platform, such as a ship, can provide LOB information on unknown contacts and potential targets in their vicinity (Fig. 1). Historically, cross LOB targeting (i.e. using data from two ships) either is not done at all or it is limited to homogeneous sensor systems (e.g. all RADAR or all acoustic sensors). For this reason, information about multiple LOBs that could localize the position of a target often does not reach a command center in time to support the decision process. Sometimes information does not arrive at a command center at all because operators do not know what to do with new data that are not correlated with existing data. Such data fail to reach the threshold of information that is complete enough to support decision confidence.

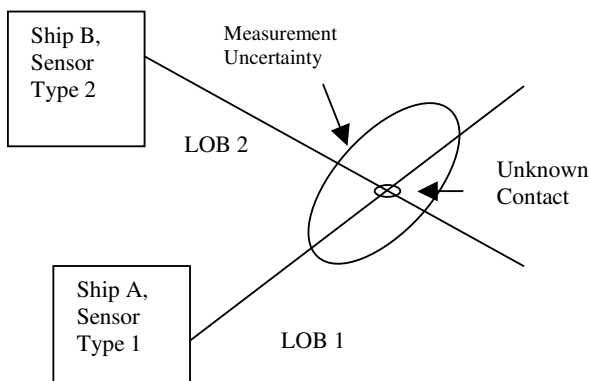

Figure 1. Platform detection geometry showing lines of bearing from ships A and B detecting an unknown contact with heterogeneous sensor types 1 and 2 [7], [8].

Commanders and equipment operators often are overloaded with tasks and uncorrelated information. They sometimes have difficulty in obtaining correct information they need to make decisions in a timely manner. Often urgent decisions are made using uncertain information. Uncertainty, in turn, contributes to battle stress. Sometimes tracks and other data are lost because they cannot be transmitted efficiently or there is no perceived payoff for their propagation. To respond to a threat, the commander may need the data that are neither available locally nor transmitted from remote sensors.

## 3. Background and Method

KMDT is exploring new approaches to FORCEnet [23] that combine technologies in novel ways to amplify the effect of each technology. KMDT is focused on knowledge management technologies such as sensor ontologies, and intelligent agents to upgrade command and intelligence centers. One goal of KMDT is to assess the impact of these technologies on information flow in the battle space and command-center operations. Improvements can be realized through the application of heterogeneous sensor data from multiple platforms to distributed tracking of unknown contacts. KMDT-related technologies, such as knowledge-management techniques, are essential for the design of next-generation tracking systems that support network-based command and control. KMDT includes modeling and simulation (M&S) of information flow in the battle space. M&S is a relatively inexpensive way to depict both baseline use and more efficient future uses of existing sensor data without costly field trials.

Distributed tracking, that is, fusing tracking information from multiple platforms at possibly different sites, is fundamental to FORCEnet. Distributed localization and tracking can be demonstrated by cross fixing of multiple LOBs obtained from heterogeneous (e.g. acoustic, magnetic) sensor data. Cross LOBs from homogeneous sensor data are used routinely in ship and aircraft navigation to determine position. However, the use of heterogeneous sensor data to determine the position, classification and identity of unknown contacts and potential targets in the battle space has not been utilized effectively. Often new track and other data are discarded when they are incomplete or too fragmented to correlate with existing data. However, tracks may be lost because correlated data from other sensors and observations are not available in a timely manner.

The LOB calculation requires different sensors, and in some cases, disparate sensor types to localize platform positions and reduce tracking uncertainty and errors. To a first approximation, the uncertainty of the target's position is minimized when LOBs cross at right angles. With sensors distributed on various ships, the intelligent agents can seek to select LOB data from a ship with near-right-angle geometry. (See Fig. 1).

Multiple sensor ontologies combined in a single format can increase understanding of message content and provide agents reference material for selecting the right platforms from which to retrieve data. Intelligent agents can access the sensor ontology [17], obtain tasking from command centers, and provide alerts when critical thresholds are crossed. The agents can relieve overloaded operators by retrieving more complete information from existing heterogeneous sources. The availability in the battle space of this additional information aims to reduce tracking uncertainty and targeting errors.

The focus of the modeling-and-simulation phase of the program is on the information required in messages to improve command-decision efficiency. In the KMDT modeling-and-simulation scenario, sensor data are transmitted in messages from intelligent agents on a network. This involves examination of the content of web pages posted by various ships on the network as well as messages that arrive in a command center via existing message systems. The design of the simulation includes both simulated baseline measurements and the same measurements made after the deployment of agents to acquire and process sensor data. It utilizes the results of agent-based data fusion by improving message-content comprehensiveness to reduce uncertainty. The KMDT design calls for data that are generated in the simulation to be posted to web portals. Intelligent agents access these web portals to search for specific data needed in the command centers that deploy them. In the simulation, this represents information flowing between various platforms in the battle space. Each friendly platform has a web portal and each sensor has a page where data are posted about that sensor, which constitutes a de facto message system.

An example scenario that is designed to model the situation depicted in Figs. 1 and 2 is under development to show how KMDT can be used in future command-and-control operations. A commander on board ship A receives a report from local sensors of an unknown contact that cannot be classified or local-

ized using only the information in the report. An operator who supports the commander tasks an intelligent track-fusion agent, depicted in Fig. 2, to search the network for the web sites of friendly platforms and shore-based sensor stations that have observed the unknown contact as demonstrated by the cross LOBs posted to the web portal during the same time period. If possible, the agent-assisted operator will select LOBs situated roughly at 90 degrees to the unknown contact, as depicted in Fig. 1. Using the secure network as depicted in Fig. 2, the agent locates the web portal ship B, the position of which fits the criteria for cross LOB, preferably at or near a right angle. Thus, the unknown contact can be localized. In the case of heterogeneous fusion, in which the sensor types are different, the agent can use the sensor ontology to determine classes of contacts that could generate the signals observed on ships A and B.

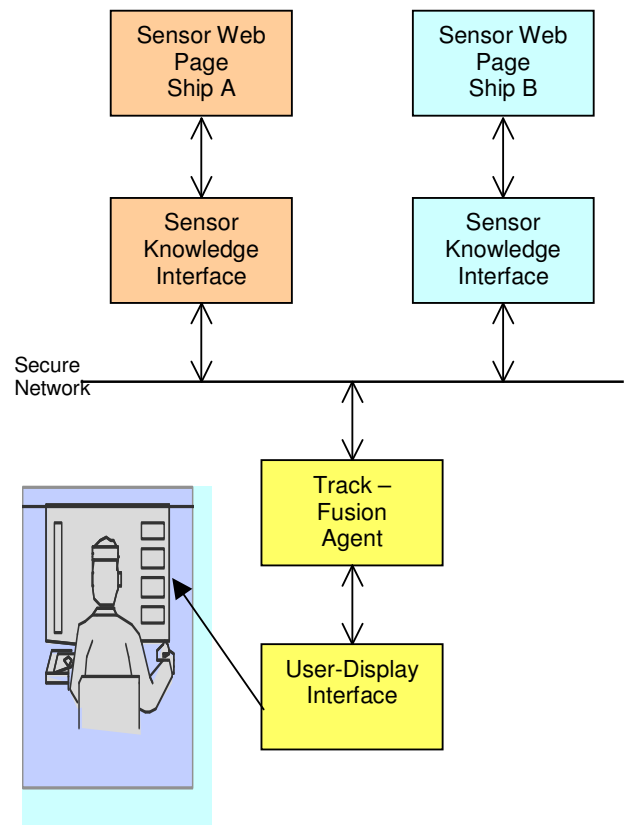

Figure 2. KMDT concept of operations, as shown in this agent - application functional diagram [8]

Agents and ontologies also can be used to assist operators in classification when the position of the target is already known. In this case, the agent also uses the sensor ontology to correlate the known capabilities of the friendly ship with the kinds of informa-

tion that could be combined with the radar data of Ship A to yield a positive classification of the unknown contact. The agent obtains detailed information about the unknown contact, such as a LOB, sensor type, and sensor data from Ship B and returns this information to the operator on ship A. The operator fuses this information with the radar contact from ship A and recommends a classification (hostile, friendly or neutral) of the unknown contact to the commander who now has enough information to take action.

#### 4. Concepts implicit in symbology

A discussion of sensor concepts in level-one sensor-data fusion is incomplete without invoking concepts from data fusion at levels two (situation assessment) and three (threat assessment). Our divisions into levels one, two, three, etc. are arbitrary categorizations of what in practice is a more continuous and connected flow of activity. For example, what is commonly viewed as level-one data fusion, such as the classification of an entity in the battle space as hostile, friendly or neutral, involves concepts from situation and threat assessment. Moreover, by limiting classification categories to hostile, friendly or neutral, we automatically exclude other concepts designed to express qualitative uncertainty, confidence of the situation, or potential threat level.

Data elements, data sets, and data structures, whether they are found in databases or on web pages, are abstractions of the physically observable world. (See, for example, [1]). Databases constitute a state of information [3] that represents measurable or otherwise observable facts about physical objects, events, experiences, and concepts. Symbols used in military command-and-control displays and decision-support

system are higher-order abstractions that represent data on the location, classification, type and capabilities of platforms and targets in single integrated picture (SIP). Thus, symbols are meta-abstractions, or abstractions about abstractions. As such, a study of the symbology of a particular military community provides an insight into the concepts that are used in that community and the relative importance each concept or category of concepts in a particular community. The more important the concept, the more detailed and category-intensive that concept will be within that community.

Consider the dichotomy of the tactical and the analytical mindsets. In tactical operations, quick decisions often are required using limited amounts of information. Thus to support decisive action, the symbols used in the tactical community tend to be concise and limited in detail to concepts such as hostile, friendly, neutral or unknown, air, surface and subsurface.

For example, the Naval Tactical Display System (NTDS) target classification ontology is depicted in Fig. 3. It is based on the category type and color coding standard symbology in [20], as well as the MIL-STD-2525B [14] symbology [20]. NTDS includes the NATO 2019 symbology designed for ground forces. NTDS is an engagement-related symbology designed to support situation awareness and rapid perception of the common operating picture. Symbols in this minimal representation have small footprints for minimal display clutter. The NTDS symbols, which also are included in the OTH-gold specification, are simple enough to be rendered as font characters for efficiency of communication.

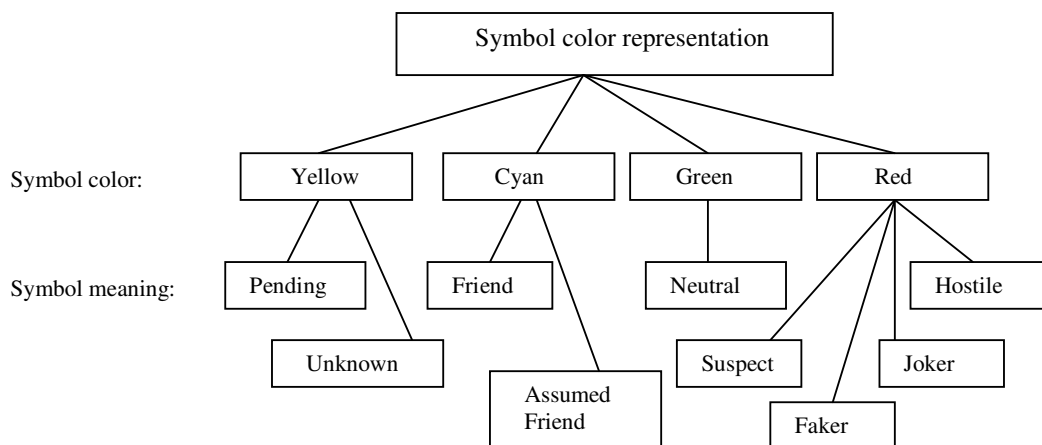

Figure 3. Target-classification ontology implicit in the NTDS frame and color-coding symbology standard [11], [20].

In contrast, force-domain symbology, described in MIL-STD-2525B [14], is preferred in the planning and analysis communities, which are not constrained by time criticality. These symbols have a larger footprint with ample surrounding text. The analytical community that uses these symbols requires more fine structure showing various details about each platform or target. These details surpass in number and in complexity the list used in the tactical community. Analysts generally do not need to make quick decisions that immediately affect operations in the same way that tacticians do. They are more concerned with the completeness, accuracy and reliability of their results. Since the devil always seems to be in the details, planners and analysts favor more detailed approaches in general. For example, the MIL-STD-2525B symbols have more fine structure and need to be rendered as graphics as opposed to font characters.

MIL-STD-2525B [14] specifies standard situation awareness symbology for practically everything that could appear on a tactical-display map. The specification has a hierarchical structure similar to a class hierarchy, starting with the most-basic concepts through very specific object classes. The hierarchy of a symbol object is specified by a sequence of numbers where each successive number represents a different level of the hierarchy. Using this sequence of numbers, and associated parameters such as location and time, display application software can identify the symbol to draw and where to put it on the user's display. A sequence of numbers is defined for line of bearing in general. By appending another number to the sequence, lines of bearing for various types of sensors, depending on the appended number's value, can be represented. Although the specification doesn't describe it this way, one can conceptualize the sensor-type LOB sequence as inheriting from the general LOB sequence similar to sub-classes inherit from super-classes. Using MIL-STD-2525B to define the basic structure of the ontology saves time because considerable effort has been dedicated to documenting an exhaustive understanding of the spatial tactical battle space in a widely known and used standard.

Consider the example of symbology from NTDS on frame and color coding [11]. This symbology includes the widely used classification of platforms and targets in the battle space that can be summarized as unknown, friendly, neutral and hostile. However, it also includes an extended more detailed list of distinct symbols that express degrees of confidence about a

target's classification. These distinct symbols represent concepts such as assumed friend (cyan), suspect (red), joker (red), and faker (red). The result of sensor data fusion can lead to platform classification according to an ontology derived in part from the NTDS Frame and color codes, as shown in Fig. 3.

The concepts encoded in the NTDS symbology are focused primarily on the status of platforms and targets in the battle space. They are used to report the best estimate of the battle situation in terms of location and classification that was determined or implied by the use of sensors and their data products. Whereas this ontology is not related directly to sensor characteristics per se, it relates very well to the products of sensor-data fusion and the expression of these results in decision-support systems designed to communicate the common-operating picture in command centers.

### 5. Sensor Ontology Structure and Integration

Sensors can be classified in various ways, such as by the physical property they detect, by whether they are active or passive, by their accuracy, by their availability, by their owner, etc. In an integrated sensor ontology, these various ways of classifying sensors would be represented by multiple inheritance links.

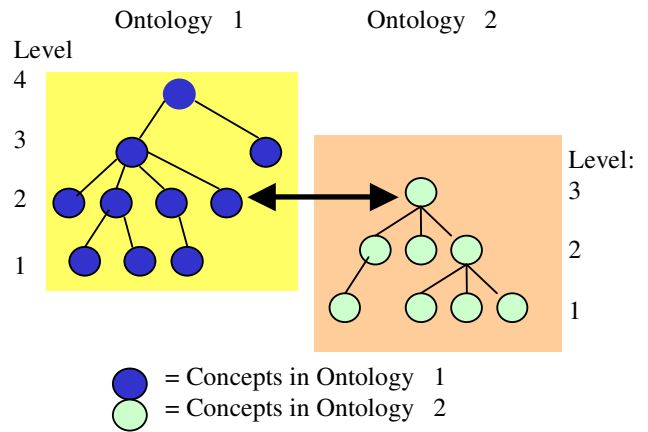

Figure 4. Example of a concept that occurs at different levels of abstraction in different ontologies.

A survey of existing sensor ontologies reported in [8] summarized some of the mappings for the ontologies found in the survey. Several ontologies were found but none was complete and no two ontologies were exactly alike [8]. No single ontology included all of the concepts in sensor-data acquisition, fusion, in-

terpretation, and usage, nor did any of the existing ontologies include all of the concepts of any other sensor ontology. Moreover, the ontologies found in the survey [8] addressed primarily noun concepts and did not contain explicit references to verbs, with the possible exception of Cyc [10], [21], which covers some sensor-related verb concepts implicitly in its upper ontology. Some concepts that occur in one ontology also can occur in another ontology but at a different level, as shown for the hypothetical example, in Fig. 4, where a concept at level 2 in ontology 1 also occurs in ontology 2 but at level 3.

Some noun concepts that pertain to sensor fusion were not found explicitly in any of the surveyed ontologies. For example, although ‘signal’ was found in three of the ontologies [8], [12], [21], characteristics that pertain to signals such as “frequency,” “period,” “wavelength,” “pulse-repetition rate,” “signal strength” and “spectrum,” were not covered in explicit detail. Also, the concept of “noise” was not covered in the sensor ontologies, although it could be part of a more general, upper ontology. Concepts associated with noise, such as “broadband” and “narrow band” were not found. The concept of a “propagation medium,” such as “air,” “water,” and “space” did not occur explicitly in any surveyed ontology, although here again, it may be present an upper ontology that does not pertain specifically to sensors. Depending on the placement of these concepts within the ontological structure, the specific data-fusion concepts will inherit characteristics from the higher and more general levels of abstraction.

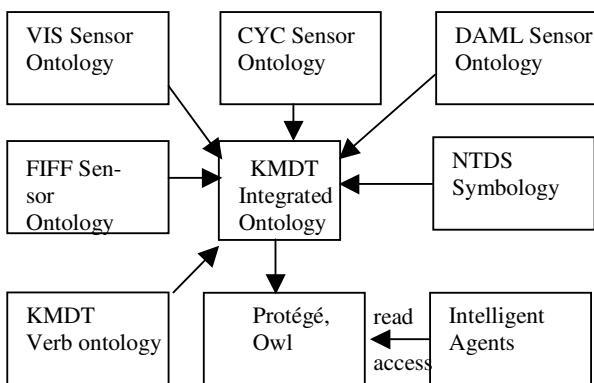

Figure 5. Sensor ontology and platform symbology integration

In Fig. 5, the various ontologies are as follows: “VIS Sensor Ontology” [8]; Cycorp’s Cyc ontology for sensor concepts [21]; the Formal Information Fu-

sion Framework [12]; J. Hendler’s sensor ontology in DAML [16], [18], [19]; and the ontology implicit in the NTDS [11], [14], [20] described in section 4.

The concept of ontology-based data fusion is discussed in [15]. Content ontology specifies concepts that include a description of what is believed to be the true nature of objects [15]. The content ontology together with the states of interest associated with a task, and the relationships within and between these states are also important parts of a sensor ontology [15]. This ontology also includes concepts about the distinction between observations such as signals from sensors and the objects that give rise to these signals [15]. Using a complete sensor ontology and database of sensor-performance characteristics, intelligent agents can obtain data available on the secure network more efficiently.

## 6. Verb Ontology and Assertions

Table 1 displays some concepts in the verb ontology. The first two rows, pertaining to signal and noise, contain assertions that are equivalent. The next two also contain equivalent statements negating the first two. The concept of negation is not needed explicitly in an ontology of this level of detail as will be part of an upper ontology from which the sensor ontology will inherit characteristics.

Table 1 also shows some examples of predicates of various arity [10], [13], [24]. In general, true ternary and quaternary predicates cannot be decomposed further into a set of predicates of lower arity, such as binary predicates. This is a result of applying the general principle of keeping arity low [10]. The ternary predicates and quaternary predicate shown in table 1 are true higher-arity predicates that express key concepts of level-one sensor-data fusion. For example, in signal detection, a human operator is “in the loop” to interpret the signals and decide what they mean. The human cannot detect, classify, identify, etc. the target without the help of sensors, including but not limited to biological sensors (e.g. eyes and ears). Sensor data alone, without processing, correlation and interpretation are of no value. If a target is not present, the sensor operator in conjunction with the sensor cannot detect anything. Thus, “operator plus signal detects target” is a true ternary predicate. The same is true for the other ternary predicates listed.

Because two signals may be required to localize a target, as in Fig. 1, “operator plus two signals localize target” can be a quaternary predicate. If the signal pertains to radar, only one may be necessary for localization, depending on the required resolution. To construct a track, at least two signals and maybe many more may be necessary. Therefore, “operator plus signals track target” is a predicate of variable arity.

Table 1. Verbs and some example assertions that express concepts in the KMDT in sensor ontology.

Subject	Verb	Object	Relationship Type; arity
Noise	Masks	Signal	Equivalent 1; Binary predicate
Signal	Is masked by	Noise	Equivalent 1; Binary predicate
Noise	Does not mask	Signal	Equivalent 2; Binary predicate
Signal	Is not masked by	Noise	Equivalent 2; Binary predicate
Signal	Propagates in	Medium	Binary predicate
Period	Is reciprocal of	Frequency	Noun inverse; Binary predicate
Frequency	Is reciprocal of	Period	Noun inverse; Binary predicate
Target	Changes	Location	Binary predicate
Target	Emits	Signal	Binary predicate
Sensor	Receives	Signal + noise	Ternary predicate
Algorithm	Processes	Signal + noise	Ternary predicate
Operator + Signal	Detect	Target	Ternary predicate
Operator + Signal	Detect	False alarm	Ternary predicate
Operator + Signal	Classify	Target	Ternary predicate
Operator + Signal	Identify	Target	Ternary predicate
Operator + Two signals	Localize	Target	Quaternary predicate
Operator + Signals	Track	Target	Variable-arity predicate
Environment	Enhances	Resolution	Verb inverse
Environment	Degrades	Resolution	Verb inverse

Inverse ontological relationships can be noun or verb inverses. For example, “period” and “frequency” are reciprocal concepts. Here the subject and object are inverses. Because the subject and object can be interchanged resulting in a valid assertion, “period” and “frequency” are called “noun inverses” in the KMDT ontology. This is different from verb inverses, an example of which is the verb pair, “enhance” and “degrade.” For example you could not interchange “environment” and “resolution” and still have valid assertions. Note that the assertion, “Environment does not degrade resolution” is not the inverse of the assertion, “Environment degrades resolution,” because it is possible (at least conceptually) that the environment could have no effect on the resolution.

## 7. Summary

A major goal of the KMDT program is to simulate network-based level-one data fusion, which directly contributes to the implementation of FORCEnet. The major technologies addressed in this program, such as ontologies, intelligent agents, LOB cross fixing and modeling are needed in command centers as future upgrades. More specifically, ontologies can organize concepts at various levels that can be of use to intelligent agents during their task execution. These concepts range from the fundamental sensor characteristics and performance that pertain to activity early in the data-fusion process to concepts in the symbology that represents data about the targets and products of sensor-data fusion displayed in command centers.

## Acknowledgements

The authors thank the Office of Naval Research and SSC, San Diego, Science and Technology Initiative for their support of this work. This paper is the work of U.S. Government employees performed in the course of employment and no copyright subsists therein. It is approved for public release with an unlimited distribution.

## References

- [1] M.G. Ceruti, “An Expanded Review of Information-System Terminology.” *Proceedings of the AFCEA Federal Database Colloquium '99*, pp. 173-191, Sep. 1999.
- [2] M.G. Ceruti, “Mobile Agents in Network-Centric Warfare,” *Institute of Electronics Information and Communication Engineers Transactions on Communications*, Japan, vol. E84-B, no. 10, pp. 2781-2785, Oct. 2001.



- [3] M. G. Ceruti, "States of Matter and States of Information," *Proceedings of ISCA's 15<sup>th</sup> International Conference on Computer Applications in Industry and Engineering (CAINE 2002)*, pp. 170-175, 7-9 Nov. 2002.
- [4] M.G. Ceruti, "Ontology for Level-One Sensor Fusion and Knowledge Discovery," *Proceedings of the 2004 International Knowledge Discovery and Ontology Workshop (KDO-2004)*, 20-24 Sep. 2004.
- [5] M.G. Ceruti and B.J. Powers, "Intelligent Agents for FORCEnet: Greater Dependability in Network-Centric Warfare," *Supplemental Volume of the Proceedings of the IEEE International Conference on Dependable Systems and Networks (DSN 2004)*, pp. 46-47, June 2004.
- [6] M.G. Ceruti, D.R. Wilcox and B.J. Powers, "Knowledge Management for Command and Control," *Proceedings of the 9<sup>th</sup> Annual Command and Control Research and Technology Symposium, CCRTS'04*, June 2004.
- [7] M.G. Ceruti and T.L. Wright, "Knowledge Management for Distributed Tracking and the Next-Generation Command and Control," *Proceedings of the IEEE International Software Metrics Symposium (METRICS-2005)*, Sep. 2005.
- [8] M.G. Ceruti, T.L. Wright, D.R. Wilcox, and Scott C. McGirr, "Modeling and Simulation for the Knowledge Management for Distributed Tracking (KMDT) Program," *Proceedings of the International Workshop on Modeling and Applied Simulation (MAS-2005)*, pp. 67-75, Oct. 2005.
- [9] V. Clark, ADM, USN, "Sea Power 21 Series – Part I: Projecting Decisive Joint Capabilities," *Naval Institute Proceedings*, vol. 128, no. 10, pp. 32-41, Oct. 2002.
- [10] Cycorp, 2002, *Predicates and Denotational Functions*, <http://72.14.203.104/search?q=cache:IUnMibkutwwJ:www.cyc.com/doc/tut/DnLoad/Arity.pdf+arity&hl=it&gl=us&ct=clnk&cd=17>
- [11] K. Fernandes, *MIL-STD 2525 Symbology Update*, Space and Naval Warfare Systems Center, San Diego.
- [12] H. Gao, *Formal Information Fusion Framework (FIFF)*, Dec. 2000, <http://www.ece.neu.edu/groups/ifg/demo.ppt>
- [13] R. Green, *Arity: Java Glossary*, 1996-2006, <http://mindprod.com/jgloss/arity.html>
- [14] Lead Standardization Activity (LSA), Center for Standards (CFS), *Department of Defense Interface Standard Common Warfighting Symbology*, MILSTD2525B, Reston, VA, Jan. 1999.
- [15] J. Llinas, C. Bowman, G. Rogova, A. Steinberg, E. Waltz and F. White, "Revisiting the JDL Data Fusion Model II," *The 7<sup>th</sup> International Conference on Information Fusion (FUSION 2004)*, June 2004.
- [16] J. Hendler, *DAML Sensor Ontology*, <http://www.mindswap.org/~evren/services/sensor-jpa.daml>
- [17] C.J. Matheus, D. Tribble, M.M. Kokar, M.G. Ceruti and S.C. McGirr, "Towards a Formal Pedigree Ontology for Level-One Sensor Fusion," *Proceedings of the 10<sup>th</sup> International Command and Control Research and Technology Symposium (ICCRTS 2005)*, June 2005.
- [16] D.L. McGuinness, R. Fikes, J. Hendler and L.A. Stein, "DAML+OWL An Ontology Language for the Semantic Web," *IEEE Intelligent Systems*, vol. 17, no. 5, Sep./Oct. 2002.
- [17] D. McGuinness and F. van Harmelen, *OWL Web Ontology Language Overview*, 2003, <http://www.w3.org/TR/owl-features/>
- [20] North Atlantic Treaty Organization (NATO) Military Agency for Standardization (MAS), *Draft Standardization Agreement Subject: Display Symbology and Colours for NATO Maritime Units*, STANAG 4420 Edition 1, Feb. 1990.
- [21] S.L. Reed and D.B. Lenat, "Mapping Ontologies into Cyc," *Proceedings of the AAAI 2002 Conference Workshop on Ontologies for the Semantic Web*, Edmonton, Canada, July 2002
- [21] E. Waltz and J. Llinas, *Multisensor Data Fusion*, Artech House, Boston 1990.
- [23] J. Waters, M. Stelmach and M.G. Ceruti, "Concepts and Applications of Composable FORCEnet," *World Science and Engineering Academy and Society Transactions on Information Science and Applications*, vol. 2 no. 12, pp. 2080 – 2087, Dec. 2005. <http://www.wseas.org>.
- [24] Wikipedia, *Arity*, Ma. 2006, <http://en.wikipedia.org/wiki/Arity>.

**Dr. Marion G. Ceruti** is a senior scientist in the Advanced Technology and Transition Branch of the Command and Control Technology and Experimentation Division at the Space and Naval Warfare Systems Center, San Diego. Dr. Ceruti's professional activities include information-systems research and analysis for command and control decision-support systems, sensor fusion, and research management. She is the author of 90 publications. Dr. Ceruti is a senior member of the IEEE and a member of the IEEE Computer Society, the Association for Computing Machinery, the Acoustical Society of America, the Armed Forces Communications and Electronics Association the International Society for Computers and Their Applications, and the New York Academy of Sciences.

**Mr. Dwight R. Wilcox** is a senior computer scientist in Effects-Based Information Systems Branch of the Command and Control Technology and Experimentation Division at the Space and Naval Warfare Systems Center, San Diego. His professional interests include many aspects of software and systems development. He is an author of papers about knowledge management for command and control.



# Sensor Ontology Integration for the Knowledge Management for Distributed Tracking (KMDT) Program

**Dr. Marion Ceruti and Dwight Wilcox,  
Space and Naval Warfare Systems Center,  
San Diego, CA, USA**

**Command and Control Research and Technology  
Symposium (CCRTS 2006)**

**20 – 22 June 2006**

**Loews Coronado Bay San Diego, CA**

# Presentation Outline

- **Introduction to KMDT**
  - Motivation for project
  - Impact on operational forces
  - Technical objectives
- **Objective 1: Line of bearing cross fixing**
- **Objective 2: Intelligent software agents**
- **Objective 3: Sensor-ontology integration**
  - Description of noun and verb ontology
- **Objective 4: Modeling and simulation**
  - Description, concepts
  - M&S Scenario

# Why KMDT?

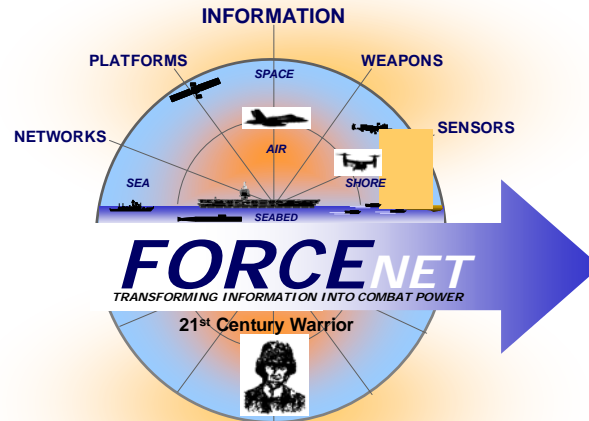

- Navy & Marines need more complete information on unknown contacts in the battle space.
- The Navy needs a better way to use more sensor information for level-one sensor fusion (<40% used.)
- Data are lost because they cannot be correlated with other data to reach the threshold of information on which decisions can be based.

# KMDT Automates Integration - Disparate Information Sources

- Automation includes network-based messages and software agents.
- Integration involves level-one data fusion.
- Heterogeneous sensor types are located on in different platforms – mobile and fixed.

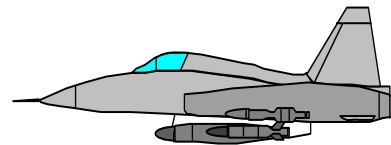
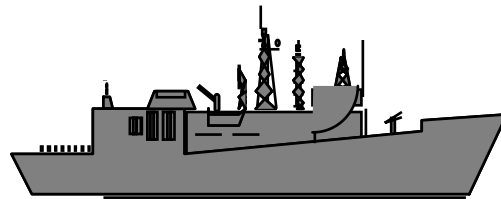

# KMDT's Operational Impact

- Agent-acquired information will support the Navy and Marine Corps to reduce uncertainty in command centers.
- Distributed homogeneous and heterogeneous sensor information will be used more efficiently.
- The network will be used to meet the same requirements as current message systems.
- Sensor ontologies will enable integration of information bases and increase understanding of the battle space.
- Help prevent fratricide incidents through better target classification.

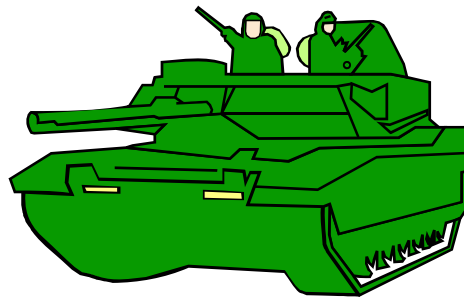

# KMDT Technical Objectives

- Develop **cross-correlation algorithm** -provides localization of unknown platforms.
- Use intelligent software **agents** to search secure networks for line-of-bearing (LOB) cross correlation and other information. **(Metrics)**
- Merge **sensor ontologies** - concepts re: different sensor types & their capabilities. **(Metrics)**
- Implement **modeling and simulation**. **(Metrics)**

**KMDT**

# KMDT Technical Objective 1: Cross-Correlation Algorithm

- Localizes unknown platforms using Line-Of-Bearing cross fixing.
- Uses both similar and disparate sensor types (e.g. electro-magnetic and acoustic) localize platform position and
- Reduces tracking uncertainty and errors

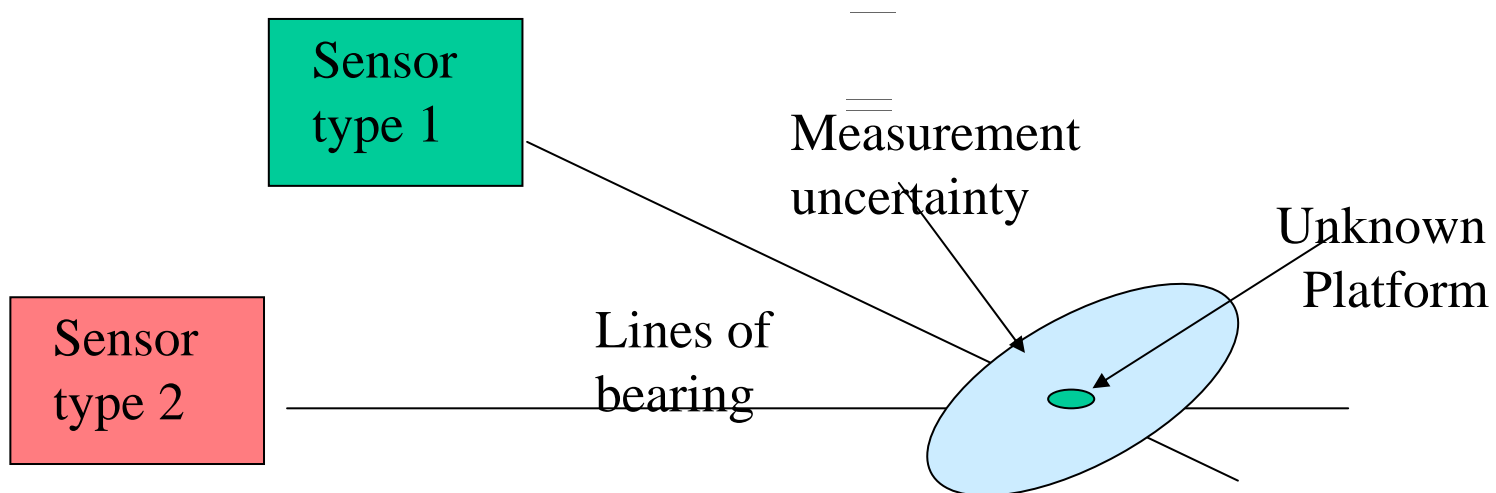



# KMDT Technical Objective 2: Intelligent Agents



- Search secure networks for line-of-bearing (LOB) cross correlation and other information.
- Access sensor ontology & database for task coordination
- Acquire sensor information at the message level for network-based correlation and tracking.
- Using the network as a medium of data sharing, agents perform message-level data retrieval, fusion and integration, thus bringing key missing data to the attention of ship commanders. =



# KMDT Application - Agent Functional Diagram

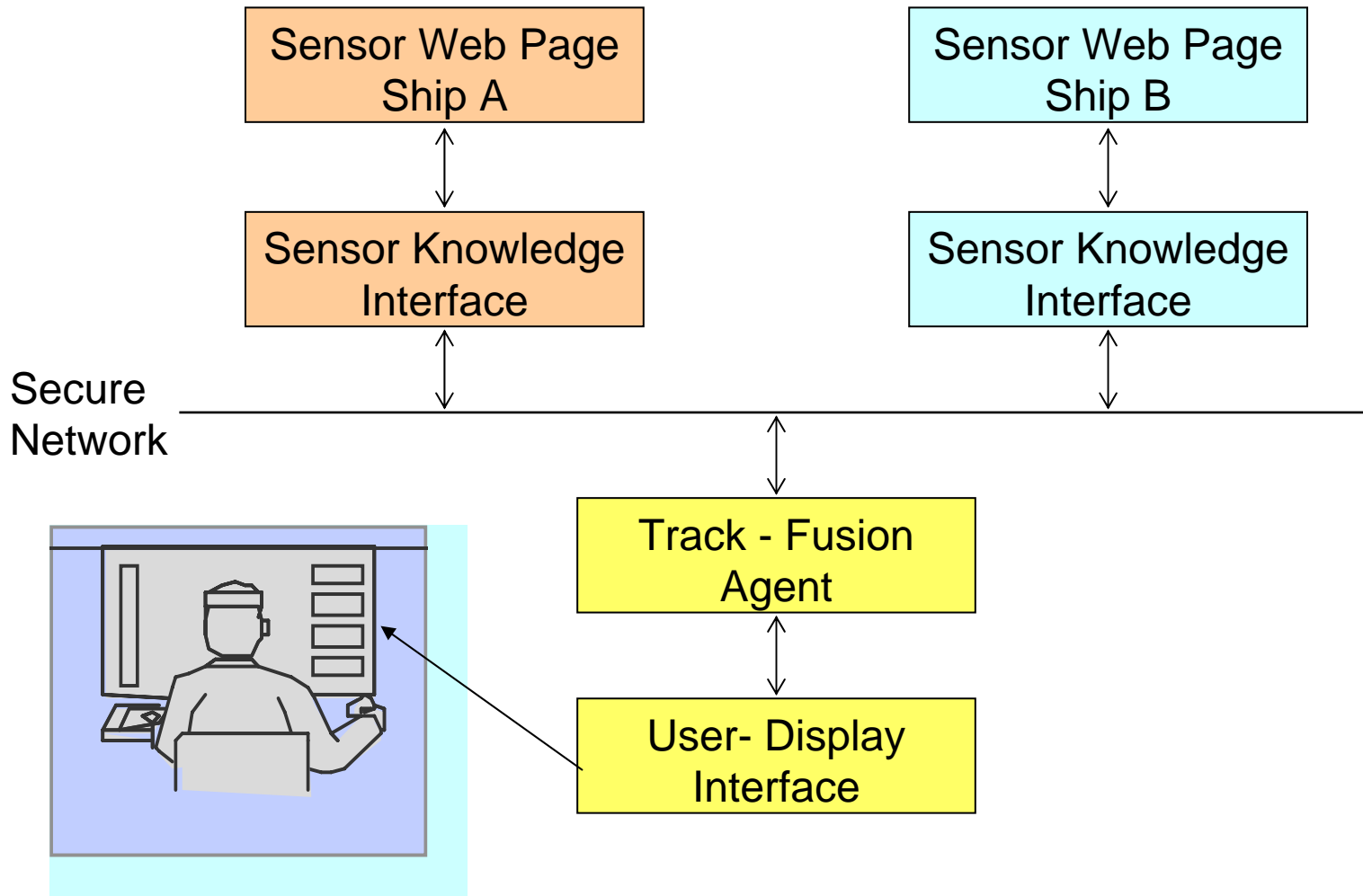

# Agent Input Screen

**Kind of Agent**

**Start Processing**

**Modify Settings**

Operator selects the the kind of agent, then modifies the parameters, instantiates, and then start processing.

The screenshot displays the KMDT Agent Manager application. In the background, a command prompt window shows the process of adding a new agent class: `C:\kmdt\agent\manager>C:\java1.5\jre\bin\java -Xmx256m -Xms20m -cp .;.. Manager rApp Adding agent class ... FileAgent java.beans.IntrospectionException: Method not found: settasks at java.beans.Introspector.<init>(PropertyDescriptor.java:93) at java.beans.PropertyDescriptor.<init>(PropertyDescriptor.java:31) at introspector.<init>(Introspector.java:285) at introspector.<init>(Introspector.java:475) at introspector.<init>(Introspector.java:385)`. The main window shows a table of agents with columns for Name, State, and Task. A context menu is open over the 'detect-log-watch' agent, with 'Start processing' selected. The 'FileAgent Customizer' dialog is also visible, showing configuration for the 'detect-log-watch' agent, including a name, file path, condition, threshold, and action string.

Agent	State	Task
detect-log-watch	Initiated	Watching file=C:\kmdt\det...

# KMDT Information Flow

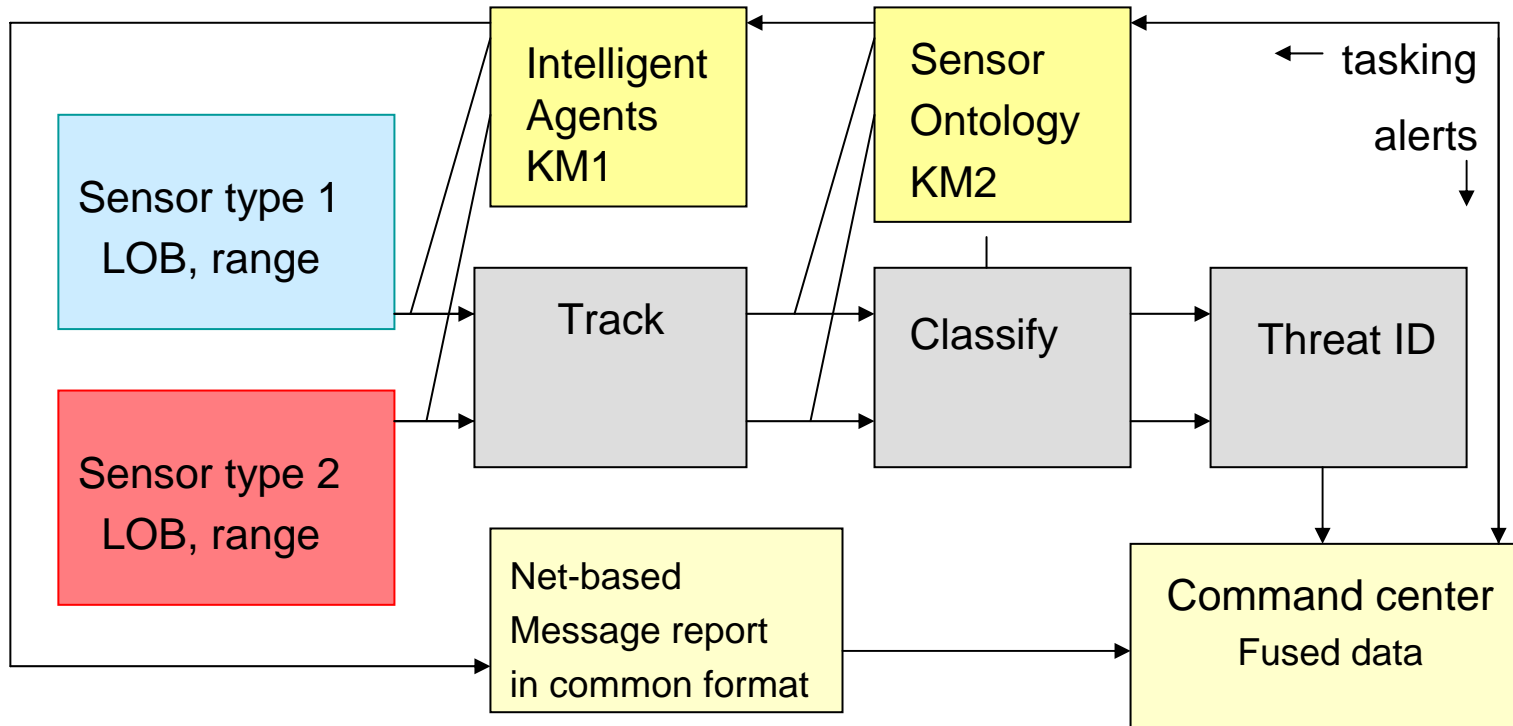

Operators in command centers task intelligent agents to find sensor data at the message level on the network.

# KMDT Technical Objective 3: Ontology - Terminology Definitions - 1



- Database - A state of information. A collection of facts structured according to a model that allows information to be stored **implicitly**. Conclusions can be **inferred** from the data.
- Ontology – Systematic account of existence. Concepts and their relationships are represented in a hierarchy that includes object and and action concepts. Every knowledge base is a representation of one or more ontologies.

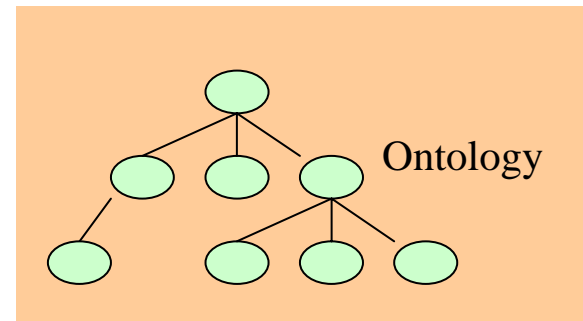
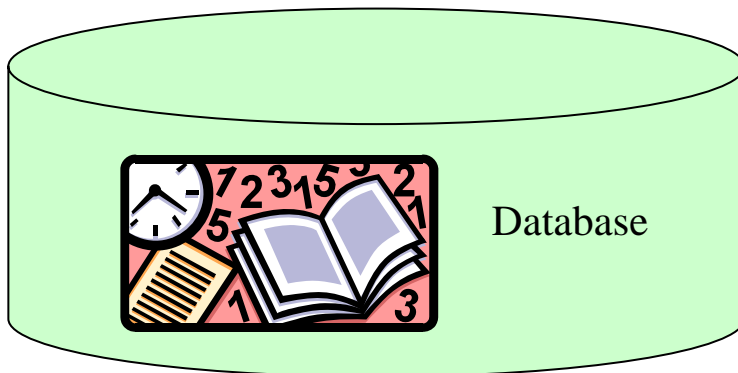

# Ontology Terminology Definitions - 2

- Knowledge base - A state of information. Can be a collection of rules structured according to an ontology that allows assertions to be stored **explicitly**. Conclusions can be drawn using an inference engine. Higher level of aggregation.

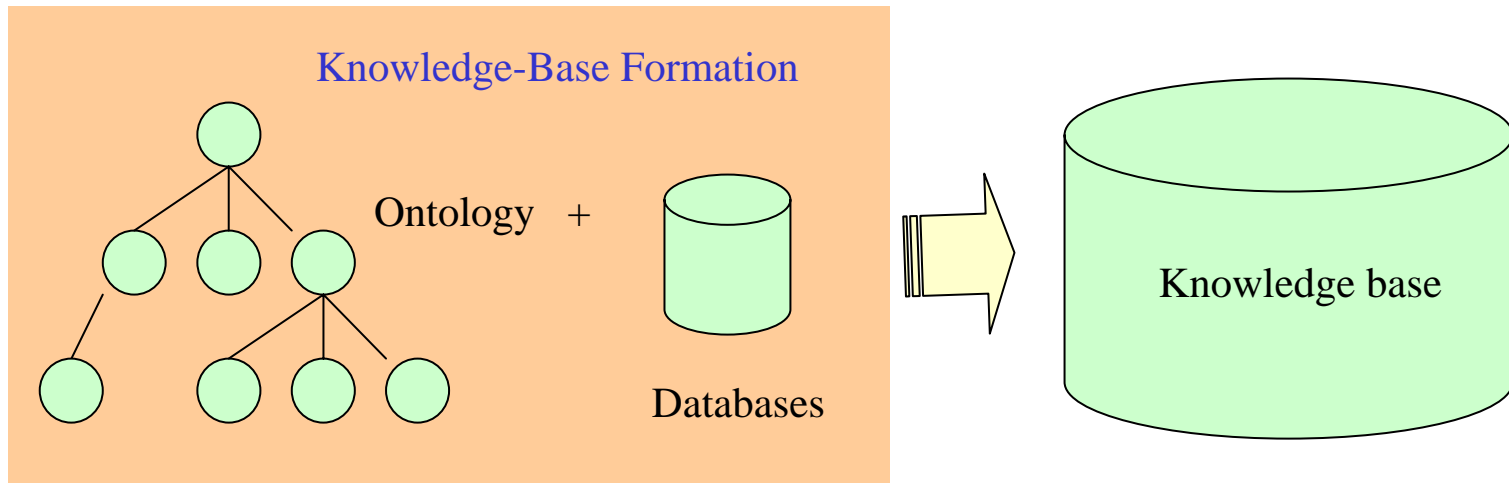

# KMDT Sensor Ontology Integration

- Common, merged sensor ontology defines concepts, maps metadata about disparate sensor systems, fills gaps not covered explicitly in an existing sensor ontology. Example: verb ontology.
- Ontology serves as the basis for a knowledge base and agent-based data fusion.
- Intelligent agents coordinate their tasks.
  - Match commander's requirements to sensor capabilities
  - Data correlation and platform tracking

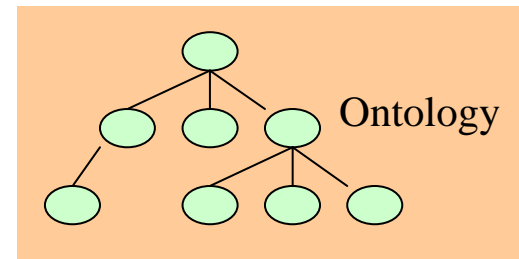

# KMDT Ontology Integration and Use

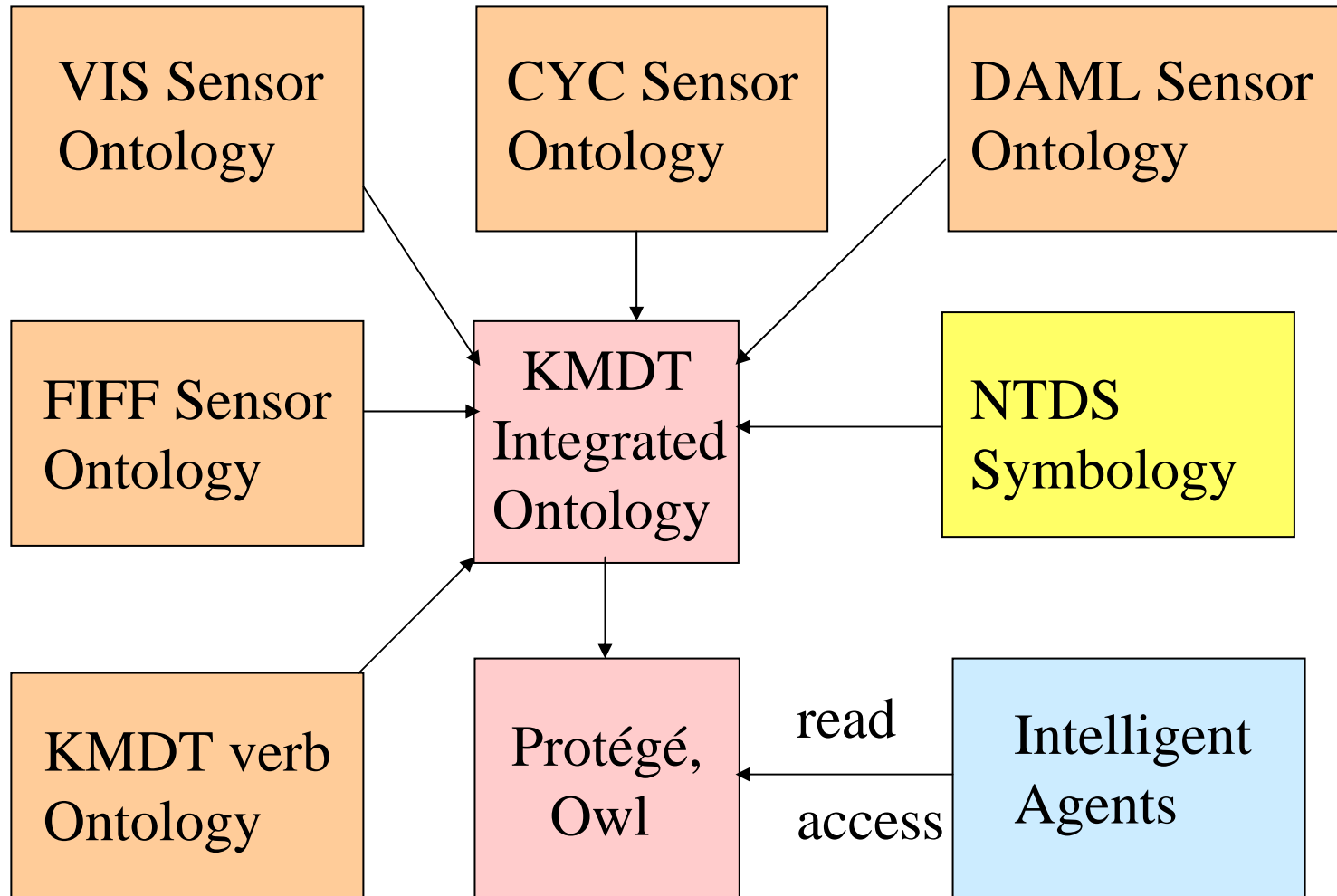



# Target-classification ontology implicit in the NTDS symbology standard

Symbol color representation

Symbol color:

Yellow

Cyan

Green

Red

Symbol meaning:

Pending

Friend

Neutral

Hostile

Unknown

Assumed  
Friend

Suspect

Faker

Joker

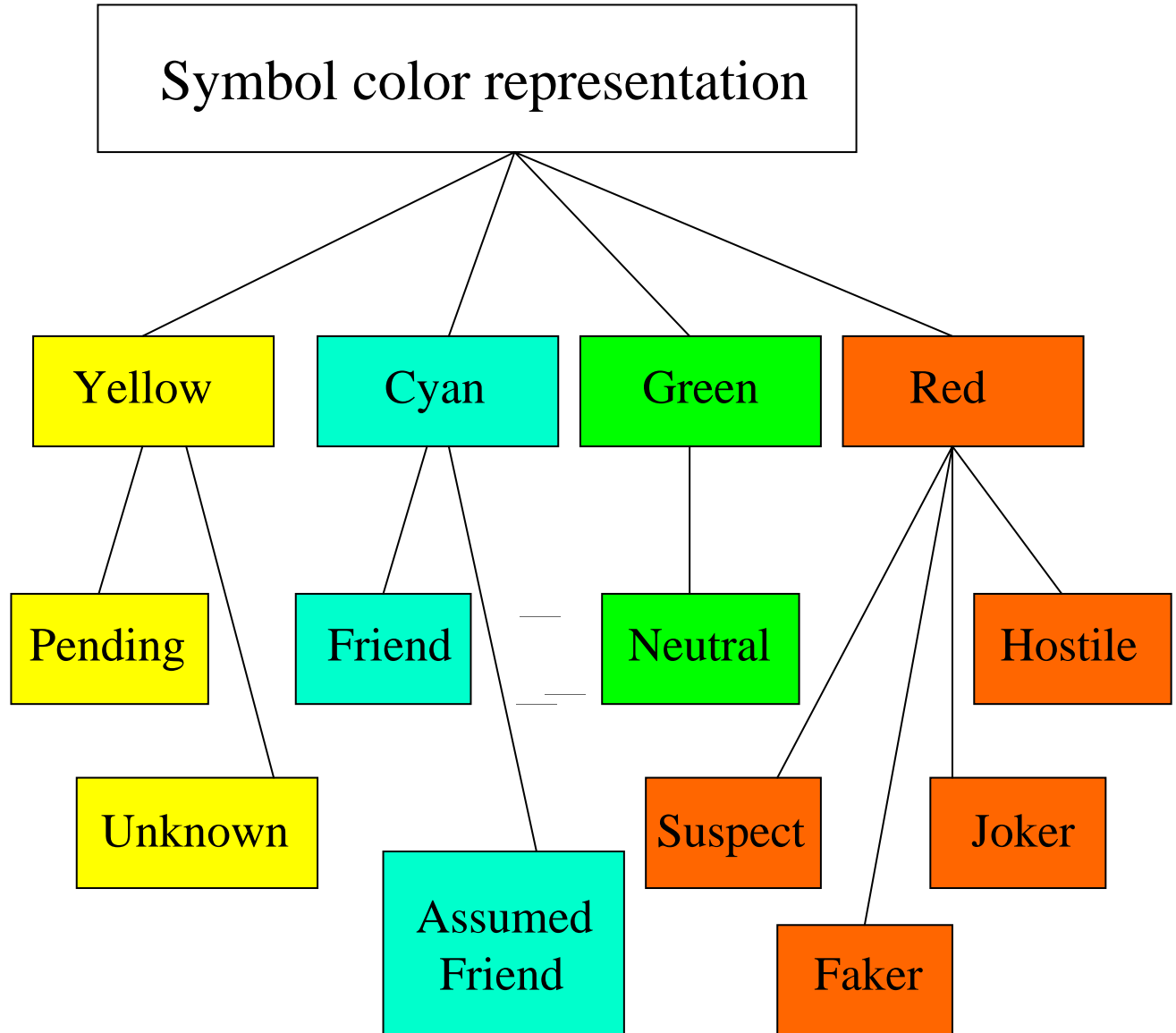

# KMDT Noun Ontology Components

Concept   Ontology	VIS	Cyc	DAML	FIFF	Davis
Sensor type:	x	x	x	x	x
Active	x	x	x	x	x
Passive		x	x	x	x
Radar		x		x	x
Acoustic	x	x			
Magnetic	x	x			
Electro-optic	x	i		x	
Electro-Magnetic		x	x	i	x
Mechanical		i	x		
Biological		x	x		
Chemical		x	x		
Radioactive			x		
Cyber		i	x		
Optical	i	x	x		
Microwave			—	x	
Geometry	x	x		x	
Track	x	i	—		
Signal	x	x	i		x
Resolution			x		
Environment	x	x			
Contact	x		x	x	
Range		x	x	x	
Goal		x	i	x	
Sensor mode			x		
Sensor location	x	x	x		i
Sensor data	x	x	x		



Systems Center  
San Diego

# Verb & Predicate Components



<u>Subject</u>	<u>Verb</u>	<u>Object</u>	<u>Relationship Type</u>	<u>Arity</u>
Noise	Masks	Signal	Equivalent 1	Binary predicate
Signal	Is masked by	Noise	Equivalent 1	Binary predicate
Noise	Does not mask	Signal	Equivalent 2	Binary predicate
Signal	<b>Is not masked by</b>	Noise	Equivalent 2	Binary predicate
Signal	Propagates in	Medium		Binary predicate
Period	Is reciprocal of	Frequency	Noun inverse	Binary predicate
Frequency	Is reciprocal of	Period	Noun inverse	Binary predicate
Target	Changes	Location		Binary predicate
Target	Emits	Signal		Binary predicate
Sensor	Receives	Signal+noise		Ternary predicate
Algorithm	Processes	Signal+noise		Ternary predicate
Operator + Signal	Detect	Target		Ternary predicate
Operator + Signal	Detect	False alarm		Ternary predicate
Operator + Signal	Classify	Target		Ternary predicate
Operator + Signal	Identify	Target		Ternary predicate
<b>Operator+2 signals</b>	Localize	Target		Quaternary predicate
Operator +Signals	Track	Target		<b>Variable-arity predicate</b>
Environment	Enhances	Resolution	Verb inverse	
Environment	Degrades	Resolution	Verb inverse	

# The Same Concept Occurs in Multiple Ontologies

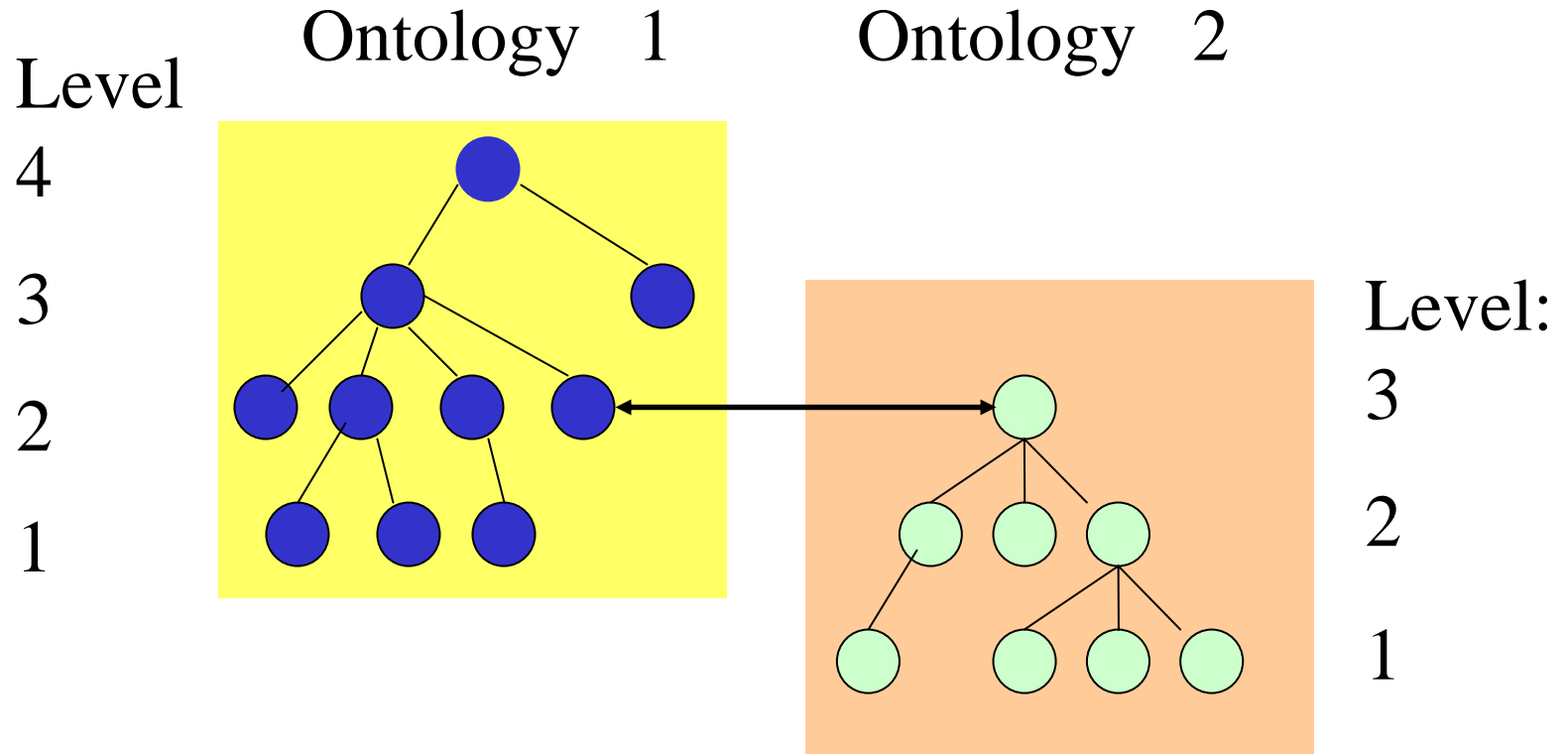

● = Concepts in Ontology 1

● = Concepts in Ontology 2

# KMDT Technical Objective 4

**Modeling and simulation.** – Focus is on agent and ontology performance at the message level to improve command-decision efficiency. Simulate agent-assisted data fusion in FORCEnet-based scenarios. (Ref. 14)

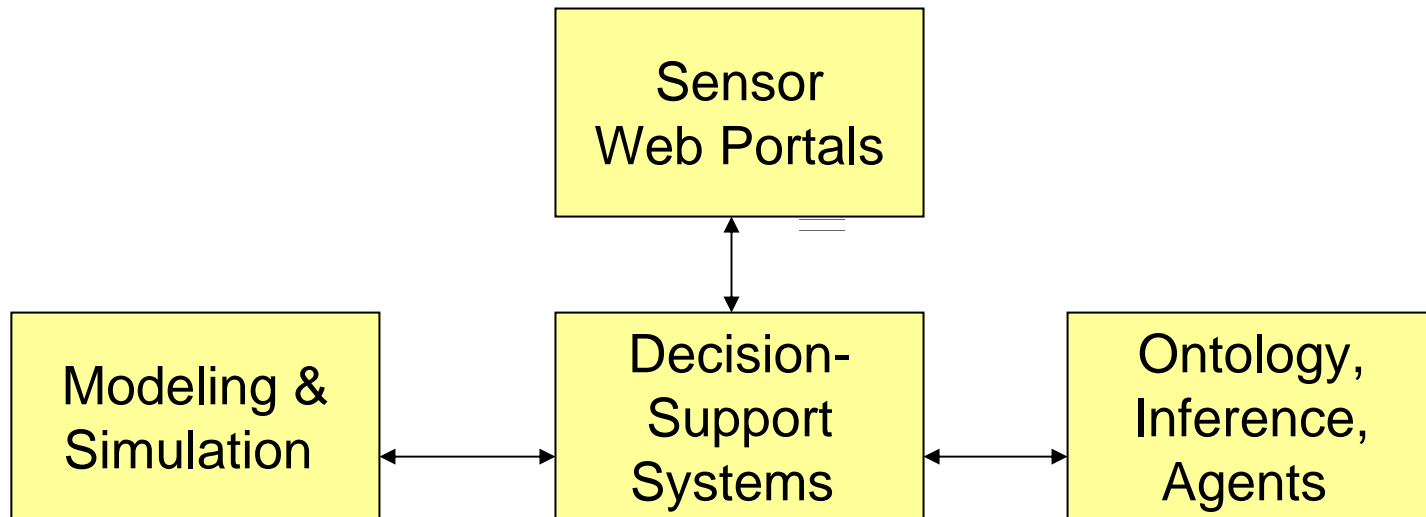

# Modeling and Simulation: Motivation

- Allows many tests to be conducted using software without costly field trials.
- Enables progressively more complex models, scenarios, and technologies to be tested systematically.
- Helps predict system behavior.

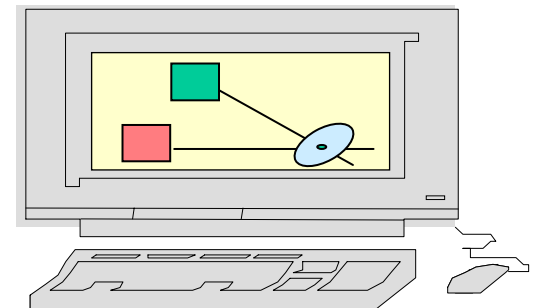

# Modeling and Simulation: Concept of Operations

- Initial effort focus is on simplified concept of operations, scenarios.
- Software intelligent agents access processed, message-level data on web portals.
- Unprocessed, "raw" sensor data:
  - Are difficult for agents to interpret.
  - Increase bandwidth requirements over the LAN.
- Messages posted to the web portals consist mainly of
  - LOB information
  - Contact frequency data derived from sensors of various types (active, passive; acoustic, optical, etc.)
  - Metadata about the contact and the remote, friendly platform that generated the LOB.

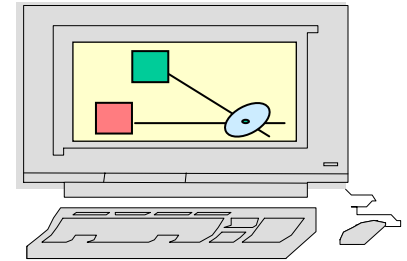

# Modeling and Simulation: Approach

- Each sensor platform has a standard web portal.
- Each sensor has a web page within the portal of the platform that controls it.
- URL are known to all nodes on the secure LAN.
- An intelligent agent is deployed to find pertinent web portals, reads data on these web portals, and evaluates whether the data on the pages satisfy a pre-determined set of criteria.
- Agents perform passive query of web portals that does not involve platform response.
- Agents access the sensor database and ontology for information in addition to that provided in the operator's input screen. – most important in heterogeneous fusion



# Modeling & Simulation Area

- Theater of operations  
(E. China sea and vicinity)
  - Littoral and deep-water environments
  - Sea access via straits and open ocean
  - Proximity of mainland and islands
    - Land-based sensor sites
    - Air bases
    - Ports of opportunity

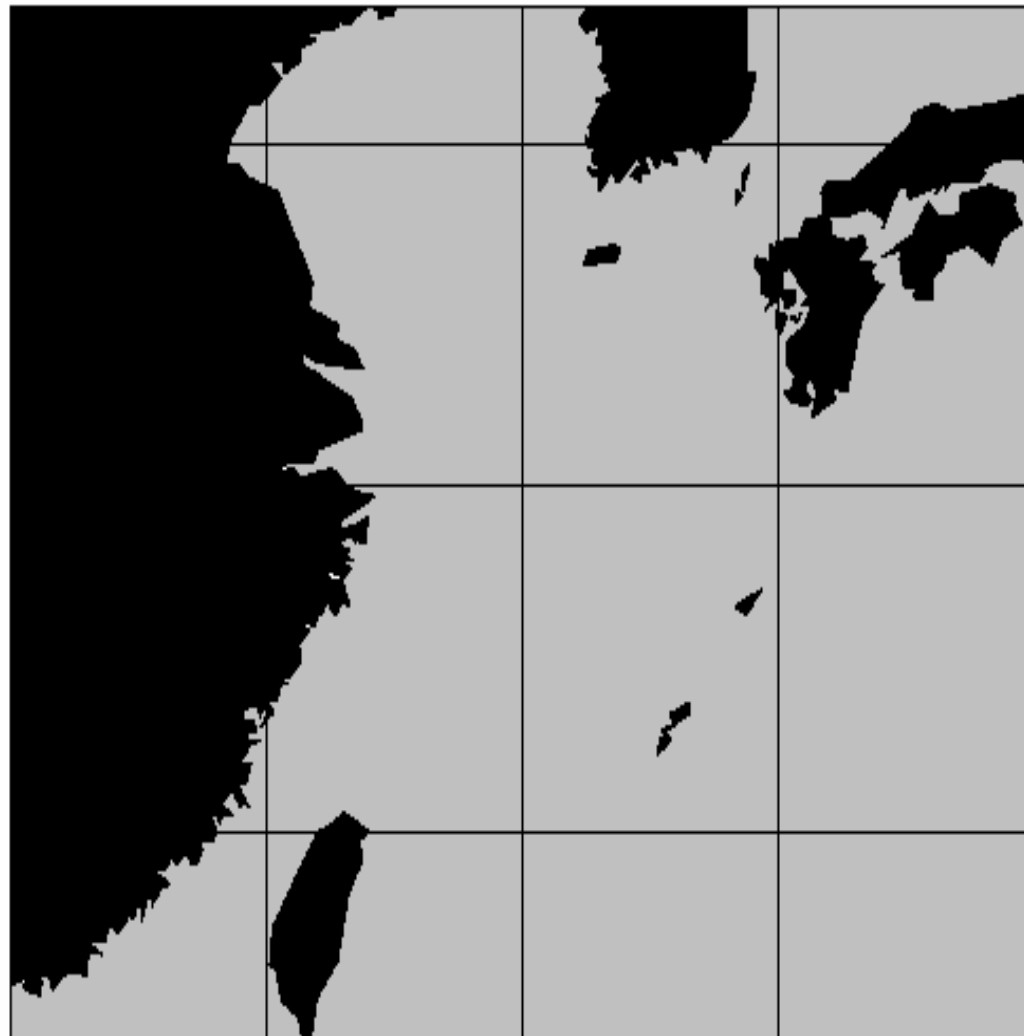

# Modeling & Simulation Features

- Targets (classification initially unknown)
  - Surface
  - Submarine (future model extension)
  - Air (future model extension)
- Sensor platforms
  - Mobile
    - Surface vessel
    - Aircraft
  - Fixed
    - Deep-water array
    - Barrier
    - Land-based
- Motion models
  - Quasi-random
  - Waypoint track

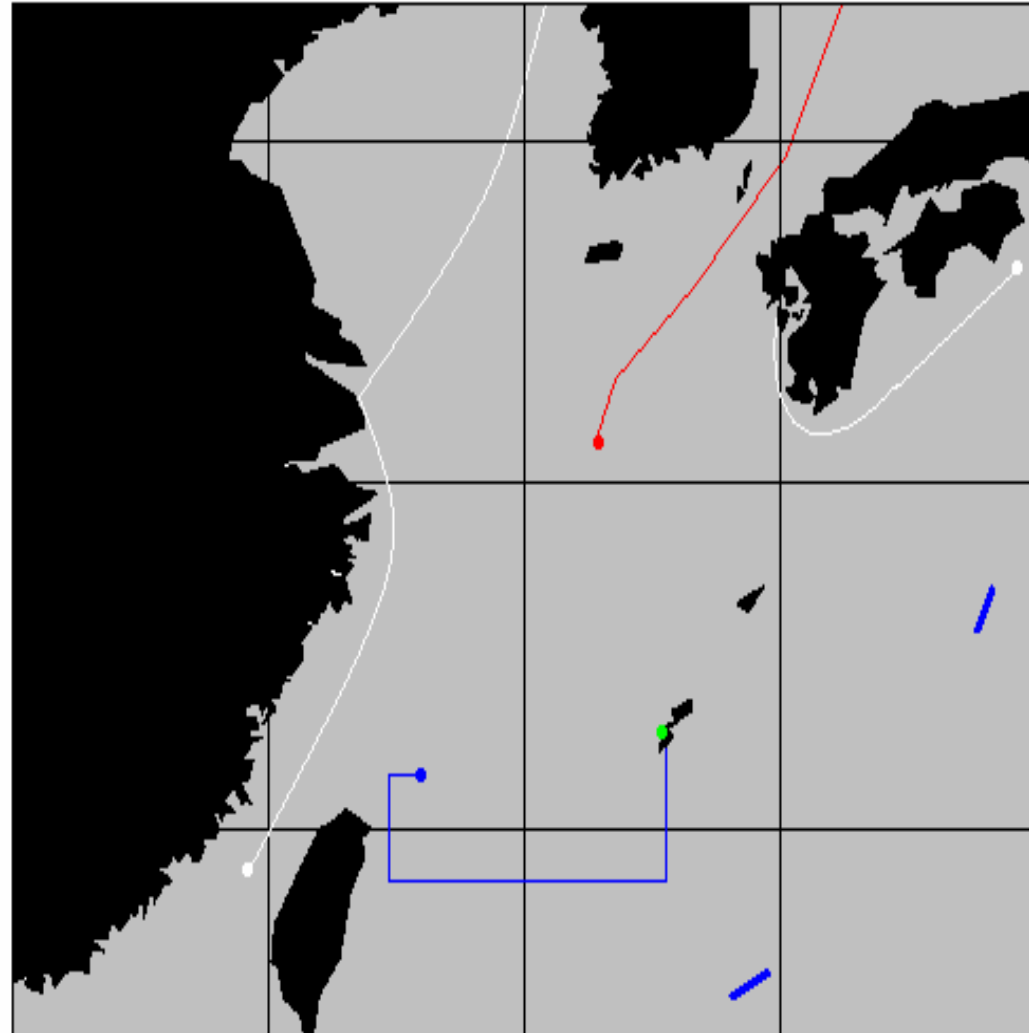

# Modeling & Simulation

## Sensor Types & Data

- Sensor systems
  - Acoustic (fixed or mobile)
    - Passive
    - Active
  - Electromagnetic (fixed or mobile)
    - Passive
    - Active
  - Optical
- Target measurements
  - Azimuth (LOB), elevation angle
  - Range, range rate
  - Pulse length, rep. Rate
  - Received SNR
  - Other classification attributes

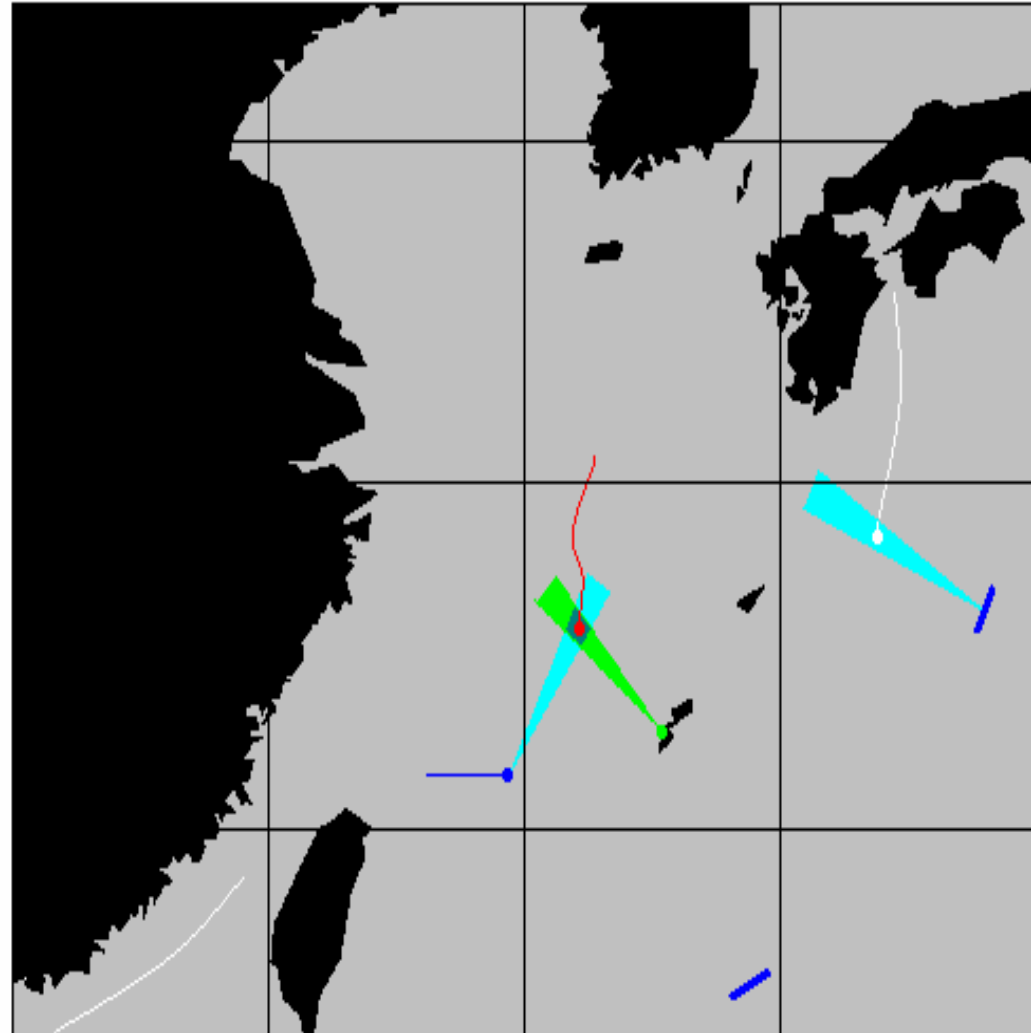



# BACKUP SLIDES



**Intelligent agents for line-of-bearing tracking.** – Agents access web portals, respond to sensor analyst tasking, seek missing data from other sensors, perform correlation and report the results on the network. Agents also can alert command-center personnel.

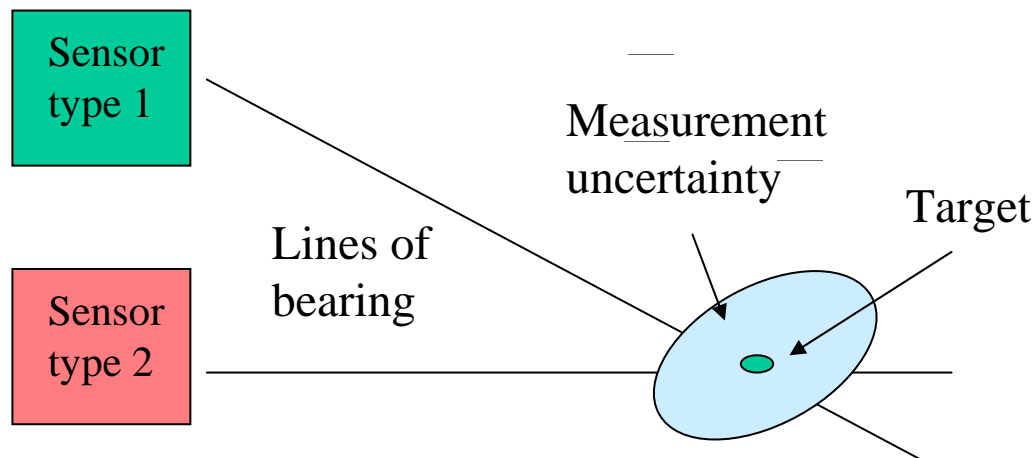

# M&S Design Details

- Platforms update their web portals when new data are received and processed at the message level.
- Each mobile platform updates its position on the web portal frequently.
- Sensor data posted on the web portal have an associated date and time.
- Frequency of update is under operator control in the simulation.
- The initial simulation design is illustrated on the next slide.

# Summary – KMDT Supports Composable FORCEnet

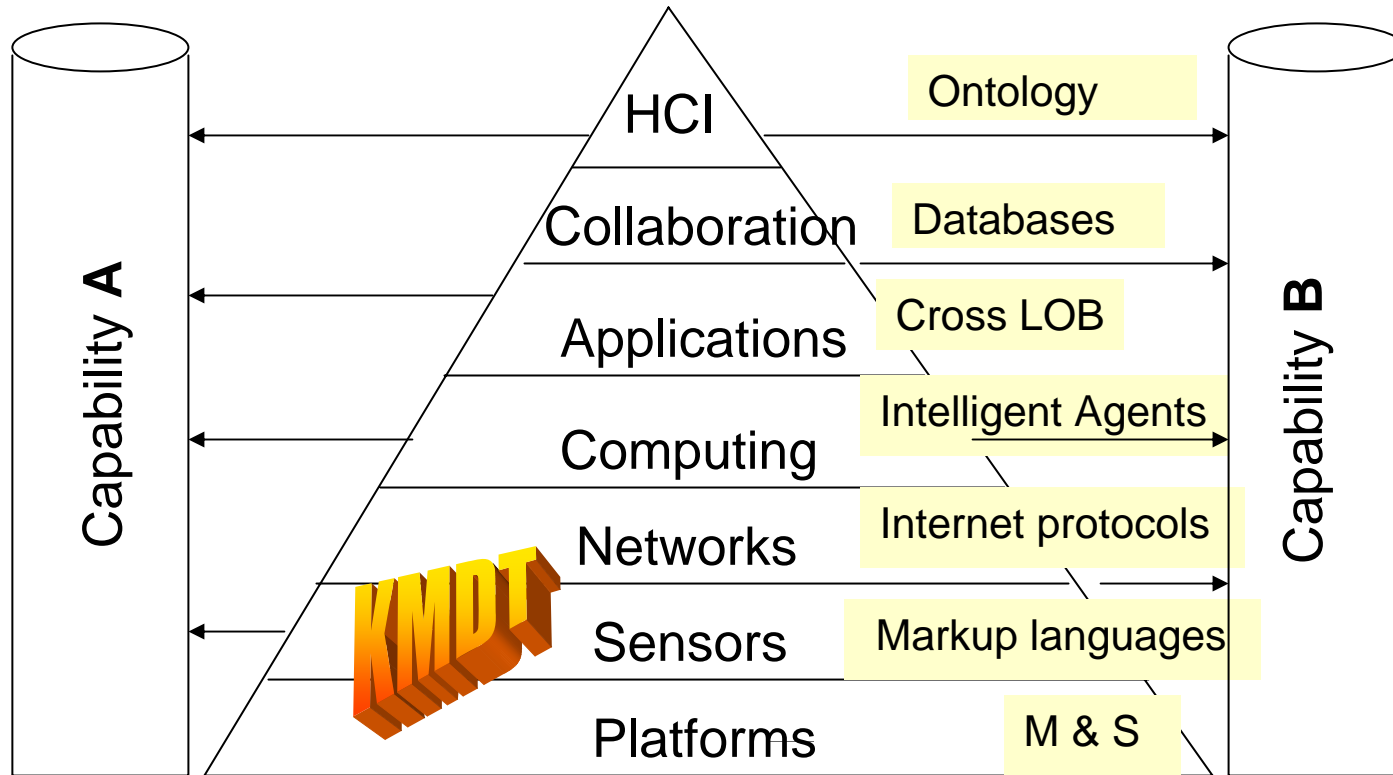

KMDT provides key enabling technologies to support composable FORCEnet. KMDT bridges the gap between capabilities: heterogeneous sensor types that otherwise would be stovepipes.

1. M.G. Ceruti, “Mobile Agents in Network-Centric Warfare,” *Institute of Electronics Information and Communication Engineers Transactions on Communications*, E84-B(10), pp. 2781-2785, Oct., 2001.
2. M.N. Kamel and M.G. Ceruti, “Knowledge Discovery in Heterogeneous Environments,” Chapter 13 in *Heterogeneous Information Exchange and Organizational Hubs*, edited by H.Bestougeff, J. E. Dubois, and B.Thuraisingham, pp. 181-204, Kluwer Publishers, June 2002. Invited chapter.
3. M. G. Ceruti and S.C. McGirr, “Data Sources Used For Target Classification” (U), *MSS National Symposium on Sensor and Data Fusion*, Aug., 2002.
4. M.G. Ceruti and J. Kaina, “Enhancing Dependability of the Battlefield Single Integrated Picture Through Metrics for Modeling and Simulation of Time-Critical Scenarios.” *Ninth International IEEE Workshop on Object-oriented Real-time Dependable Systems*, (WORDS 2003F), pp. 69-76, 1-3 Oct. 2003.
5. M.G. Ceruti, D.R. Wilcox and B.J. Powers, “Knowledge Management for Command and Control,” *Proceedings of the Command and Control Research and Technology Symposium, CCRTS’04*, June 2004.
6. M.G. Ceruti and B.J. Powers, “Intelligent Agents for FORCEnet: Greater Dependability in Network-Centric Warfare,” *IEEE International Conference on Dependable Systems and Networks (DSN 2004)*, pp. 46-47, July 2004,
7. J. D. Neushul and M.G. Ceruti, “Using XML Schema as a Validation Mechanism to Provide Semantic Consistency for Dependable Information Exchange,” *IEEE Intl. Conference on Dependable Systems and Networks July 2004*
8. J Waters, M. Stelmach and M. Ceruti, “Concepts and Applications of Composable FORCEnet,” *World Science and Engineering Academy and Society Transactions on Information Science and Applications*, 2(12), pp. 2080 – 2087, Dec. 2005.



1. M.G. Ceruti, “Ontology for Level-One Sensor Fusion and Knowledge Discovery,” *Proceedings of the 2004 International Knowledge Discovery and Ontology Workshop (KDO-2004)*, Sep. 2004.
2. C.J. Matheus, D. Tribble, M.M. Kokar, S.C. McGirr and M.G. Ceruti, “Towards a Formal Pedigree Ontology for Level-One Sensor Fusion,” *Proceedings of the Command and Control Research and Technology Symposium, ICCRTS’05*, June 2005.
3. J. D. Neushul and M.G. Ceruti, “Sensor Data Access and Integration Using XML Schemas for FORCEnet,” *SSCSD Biennial Review*, 2005. In press.
4. . M. G. Ceruti and T. L. Wright, “Knowledge Management for Distributed Tracking and the Next-Generation Command and Control,” *IEEE International Software Metrics Symposium (METRICS-2005)* Sep. 2005.
5. M. G. Ceruti, T. L. Wright, D. R. Wilcox, and S. C. McGirr, “Modeling and Simulation for the Knowledge Management for Distributed Tracking (KMDT) Program,” *Proceedings of the International Workshop on Modeling and Applied Simulation (MAS-2005)* Oct. 2005, pp. 67-75.