



REPLY TO
ATTENTION OF

DEPARTMENT OF THE ARMY
US ARMY DEFENSE AMMUNITION CENTER
1 C TREE ROAD
MCALESTER, OK 74501-9053

SJMAC-DEV (70-1pp)

6 February 2007

MEMORANDUM FOR SEE DISTRIBUTION

SUBJECT: Report No. 06-04C, "Transportability Testing of the Joint Modular Intermodal Platform (JMIP)", TP-94-01, "Transportability Testing Procedures"

1. Enclosed please find subject report dated January 2007.
2. The POC is the undersigned, SJMAC-DEV, DSN 956-8908.

FOR THE DIRECTOR:



JERRY W. BEAVER
Chief, Validation Engineering Division

Encl
as

DISTRIBUTION:

Commander,
ARDEC Logistics Research & Engineering Directorate (AMSRD-AAR-AIL-P) Al Galonski,
Bldg 455, Picatinny Arsenal, NJ 07806-5001
ARDEC Logistics Research & Engineering Directorate (AMSRD-AAR-AIL-F)
Robert Holt/Tom Sieffert, Picatinny Arsenal, NJ 07806-5001
U.S. Army Joint Munitions Command (AMSJM-TT) Richard Nesbitt, Rock Island, IL
61299-6000
ARDEC Logistics Research & Engineering Directorate (AMSRD-AAR-AIL-P-(R))
Dave Piskorik, Rock Island, IL 61299-7300
U.S. Army Aviation & Missile Command (AMSAM-MMC-MM-DT), Redstone Arsenal, AL
35898-5070
U.S. Army Materiel Command (AMSAM-LG), 5001 Eisenhower Avenue, Alexandria, VA
22333-0001

(CONT)

SJMAC-DEV

SUBJECT: Report No. Report No. 06-04C, "Transportability Testing of the Joint Modular Intermodal Platform (JMIP)", TP-94-01, "Transportability Testing Procedures"

DISTRIBUTION (CONT):

Director,

Defense Technical Information Center, 8725 John J. Kingman Road, Suite 0944, Fort Belvoir,
VA 22060-6218

Military Traffic Management Command-Transportation Engineering Agency (MTTE-DPE/
Mr. Cato), 720 Thimble Shoals Blvd., Newport News, VA 23606-2574

Commandant,

U.S. Army Ordnance Missile & Munitions Center & School

(ATSK-CMT-Z), James Kisner, Redstone Arsenal, AL 35897-6095

U.S. Army Transportation School (ATSP-CDT), Fort Eustis, VA 23604

**FINAL REPORT
JANUARY 2007**

REPORT NO. 06-04C



**TRANSPORTABILITY TESTING OF THE JOINT MODULAR
INTERMODAL PLATFORM (JMIP)
TP-94-01,
“TRANSPORTABILITY TESTING PROCEDURES”**

Prepared for:

Distribution Unlimited:

TACOM/ ARDEC
Logistics Research and Development Activity
ATTN: AMSRD-AAR-AIL-F
Picatinny Arsenal, NJ 07806



**DEFENSE AMMUNITION CENTER
VALIDATION ENGINEERING DIVISION
MCALESTER, OKLAHOMA 74501-9053**

AVAILABILTY NOTICE

A copy of this report will be furnished each attendee on automatic distribution. Additional copies or authority for reprinting may be obtained by written request from:

Director
U.S. Army Defense Ammunition Center
ATTN: SJMAC-DEV
1 C Tree Road, Bldg. 35
McAlester, OK 74501-9053

DISTRIBUTION INSTRUCTIONS

Destroy this report when no longer needed. Do not return.

Citation of trade names in this report does not constitute an official endorsement.

The information contained herein will not be used for advertising purposes.

**TRANSPORTABILITY TESTING OF THE
JOINT MODULAR INTERMODAL PLATFORM (JMIP)
TP-94-01, REV. 2, JUNE 2004,
“TRANSPORTABILITY TESTING PROCEDURES”**

ABSTRACT

The U.S. Army Defense Ammunition Center (DAC), Validation Engineering Division (SJMAG-DEV), was tasked by the Logistics Research and Development Activity (AMSRD-AAR-AIL-F), Picatinny Arsenal, NJ to conduct transportability retesting on the Joint Modular Intermodal Platform (JMIP) manufactured by SEA BOX Inc, East Riverton, NJ. The testing was conducted in accordance with TP-94-01, Revision 2, June 2004, “Transportability Testing Procedures.”

The change on the JMIP from the unit previously tested (Report 06-04 A3) was that the pin and locking mechanism that supported the A-frame in the container transport position was redesigned.

The objective of the testing was to evaluate the change in the design of the pin and locking mechanism that secured the A-frame in the container transport position when transportability tested in accordance with TP-94-01, Revision 2, June 2004.

The following observations resulted from the testing of JMIP:

1. Movement of the adjustment bolt on the cams did occur during the testing. The movement of the cam locking bolt was not significant enough to cause excessive movement of the JMIP. Future designs of the cam locking devices should prevent the bolts from moving in or out.
2. The pin and locking mechanism that held the A-frame in the container transport position completed the testing without failure or damage.

The JMIP, with interface frames, as currently designed, is adequate to be used to transport the Navy JMIC containers with ammunition, on/off road, in an intermodal container during the LMUA.

The maximum gross weight (platform and payload weight) is **not to exceed 15,000 pounds** during the LMUA.

Prepared by:

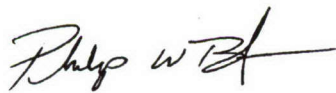

PHILIP W. BARICKMAN
Lead Validation Engineer

Reviewed by:

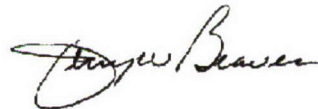

JERRY W. BEAVER
Chief, Validation Engineering Division

U.S. ARMY DEFENSE AMMUNITION CENTER

VALIDATION ENGINEERING DIVISION
MCALESTER, OK 74501-9053

REPORT NO. 06-04C

**Transportability Testing of the Joint Modular Intermodal Platform (JMIP)
TP-94-01, Revision 2, June 2004 "Transportability Testing Procedures"**

TABLE OF CONTENTS

PART	PAGE NO.
1. INTRODUCTION	1-1
A. BACKGROUND	1-1
B. AUTHORITY	1-1
C. OBJECTIVE.....	1-1
D. OBSERVATIONS	1-1
E. CONCLUSION.....	1-2
2. ATTENDEES.....	2-1
3. TEST EQUIPMENT	3-1
4. TEST PROCEDURES	4-1
A. RAIL TEST	4-1
B. ON/OFF ROAD TESTS	4-3
1. HAZARD COURSE	4-3
2. ROAD TRIP.....	4-4
3. PANIC STOPS	4-4
4. WASHBOARD COURSE	4-4
C. OCEAN-GOING VESSEL TEST. STS	4-4
5. TEST RESULTS.....	5-1
5.1 TESTING DATE –17 November 2006	5-1
A. ON/OFF ROAD TESTS.....	5-2
1. HAZARD COURSE	5-2
2. ROAD TRIP	5-3
3. PANIC STOPS	5-3
4. HAZARD COURSE	5-4
5. WASHBOARD COURSE.....	5-5
B. OBSERVATIONS.....	5-5
C. CONCLUSIONS	5-5
DRAWINGS.....	6-1

PART 1 – INTRODUCTION

A. BACKGROUND. The U.S. Army Defense Ammunition Center (DAC), Validation Engineering Division (SJMAC-DEV), was tasked by the Logistics Research and Development Activity (AMSRD-AAR-AIL-F), Picatinny Arsenal, NJ to conduct transportability retesting on the Joint Modular Intermodal Platform (JMIP) manufactured by SEA BOX Inc, East Riverton, NJ. The testing was conducted in accordance with TP-94-01, Revision 2, June 2004 “Transportability Testing Procedures.”

The change on the JMIP from the unit previously tested (Report 06-04 A3) was that the pin and locking mechanism that supported the A-frame in the container transport position was redesigned.

B. AUTHORITY. This test was conducted IAW mission responsibilities delegated by the U.S. Army Joint Munitions Command (JMC), Rock Island, IL. Reference is made to the following:

1. AR 740-1, 15 June 2001, Storage and Supply Activity Operation.
2. OSC-R, 10-23, Mission and Major Functions of U.S. Army Defense Ammunition Center (DAC) 21 Nov 2000.

C. OBJECTIVE. The objective of the testing was to evaluate the change in design of the pin and locking mechanism that secured the A-frame in the container transport position when transportability tested in accordance with TP-94-01, Revision 2, June 2004.

D. OBSERVATIONS.

1. Movement of the adjustment bolt on the cams did occur during the testing. The movement of the cam locking bolt was not significant enough to cause excessive movement of the JMIP. Future designs of the cam locking devices should prevent the bolts from moving in or out.

2. The pin and locking mechanism that held the A-frame in the container transport position completed the testing without failure or damage.

E. CONCLUSION.

The JMIP, with interface frames, as currently designed, is adequate to be used to transport the Navy JMIC containers with ammunition, on/off road, in an intermodal container during the LMUA.

The maximum gross weight (platform and payload weight) is **not to exceed 15,000 pounds** during the LMUA.

PART 2 - ATTENDEES

ATTENDEE

Philip Barickman
DSN 956-8992
(918) 420-8992

MAILING ADDRESS

Director
U.S. Army Defense Ammunition Center
ATTN: SJMAC-DEV
1 C Tree Road, Bldg. 35
McAlester, OK 74501-9053

PART 3 - TEST EQUIPMENT

1. Joint Modular Intermodal Platform
Manufactured by SEA BOX, East Riverton, NJ
Model Number: J-MIP LN702
Serial Number: 00002
Date of Manufacture: 27 February 2006
Tare Weight: 3,960 pounds

2. Joint Modular Intermodal Container
Manufactured by British Aerospace Engineering
Weight: 310 pounds
Length: 51-3/4 inches
Width: 43-3/4 inches
Height: 43-1/4 inches

3. Joint Modular Intermodal Container
Designed by Naval PHST Center - Earle, NJ
Weight: 325 pounds
Length: 51-3/4 inches
Width: 43-3/4 inches
Height: 43 inches

4. Truck, Tractor, MTV, M1088 A1
ID #: J0229
NSN: 232001-447-3893
VSN: NL1FSC
MFG Serial #: T-018488EFJM
Weight: 19,340 pounds

5. Semitrailer, flatbed, breakbulk/container transporter, 34 ton

Model #: M872A1

Manufactured by Heller Truck Body Corporation, Hillsdale, NJ

ID #: 11-1505 NX05NZ

NSN: 2330 01 109 8006

Weight: 19,240 pounds

8. Intermodal Container

ID # CMCU 200006-8

Date of Manufacture: 06/99

Manufactured by Charleston Marine Containers, Charleston, SC

Tare Weight: 4,870 pounds

Maximum Gross Weight: 67,200 pounds

PART 4 - TEST PROCEDURES

The test procedures outlined in this section were extracted from TP-94-01, "Transportability Testing Procedures," Revision 2, June 2004, for validating tactical vehicles and outloading procedures used for shipping munitions by tactical truck, railcar, and ocean-going vessel.

The rail impact will be conducted with the loaded intermodal container secured directly to the railcar. Inert (non-explosive) items were used to build the load. The test loads were prepared using the blocking and bracing procedures proposed for use with munitions (**see Part 6- Drawings for procedures**). The weight and physical characteristics (weights, physical dimensions, center of gravity, etc.) of the test loads were similar to live (explosive) ammunition.

A. RAIL TEST. RAIL IMPACT TEST METHOD. The test load or vehicle will be secured to a flatcar. The equipment needed to perform the test will include the specimen (hammer) car, four empty railroad cars connected together to serve as the anvil, and a railroad locomotive. The anvil cars will be positioned on a level section of track with air and hand brakes set and with draft gears compressed. The locomotive unit will push the specimen car toward the anvil at a predetermined speed, then disconnect from the specimen car approximately 50 yards away from the anvil cars allowing the specimen car to roll freely along the track until it strikes the anvil. This will constitute an impact. Impacting will be accomplished at speeds of 4, 6, and 8.1 mph in one direction and at a speed of 8.1 mph in the reverse direction. The tolerance for the speeds is plus 0.5 mph, minus 0.5 mph for the 4 mph and 6 mph impacts, and plus 0.5 mph, minus 0 mph for the 8.1 mph impacts. The impact speeds will be determined by using an electronic counter to measure the time for the specimen car to traverse an 11-foot distance immediately prior to contact with the anvil cars (see Figure 1).

ASSOCIATION OF AMERICAN RAILROADS (AAR)

STANDARD TEST PLAN

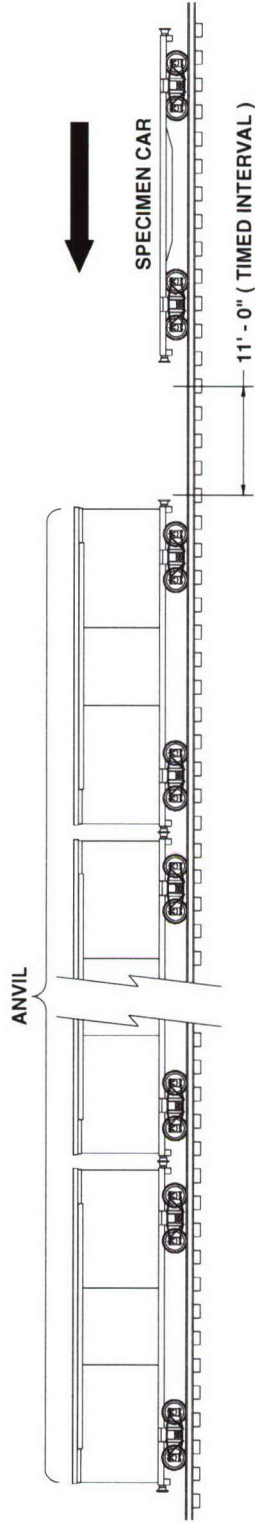

**4 BUFFER CARS (ANVIL)
WITH DRAFT GEAR
COMPRESSED AND AIR BRAKES IN A SET
POSITION**

ANVIL CAR TOTAL WT. 250,000 LBS (APPROX)

**SPECIMEN CAR IS RELEASED BY SWITCH ENGINE
TO**

ATTAIN: IMPACT NO. 1 @ 4 MPH

IMPACT NO. 2 @ 6 MPH

IMPACT NO. 3 @ 8.1 MPH

**THEN THE CAR IS REVERSED AND RELEASED BY
SWITCH ENGINE TO ATTAIN:**

IMPACT NO. 4 @ 8.1 MPH

Figure 1. Rail Impact Sketch

B. ON/OFF ROAD TEST.

1. HAZARD COURSE. The test load or vehicle will be transported over the 200-foot-long segment of concrete-paved road consisting of two series of railroad ties projecting 6 inches above the level of the road surface. The hazard course will be traversed two times (see Figure 2).

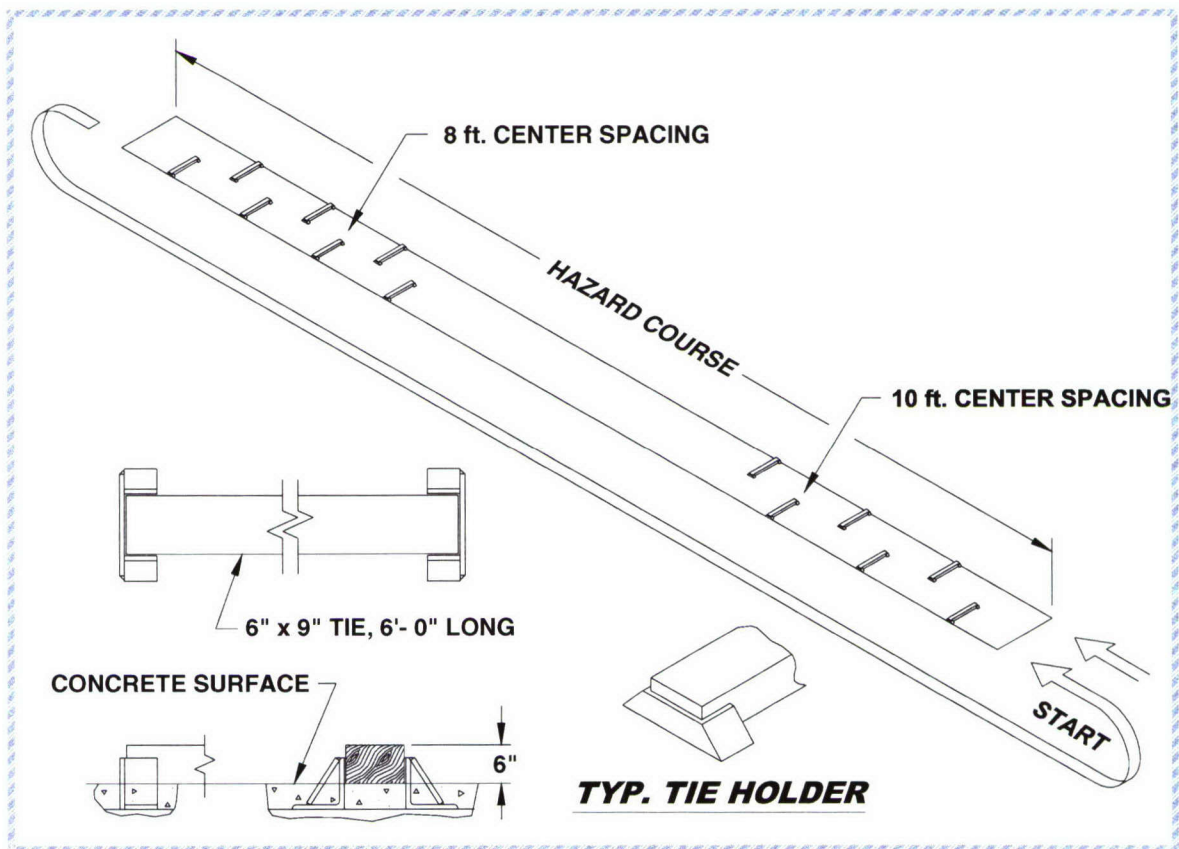

Figure 2. Hazard Course Sketch

a. The first series of 6 ties are spaced on 10-foot centers and alternately positioned on opposite sides of the road centerline for a distance of 50 feet.

b. Following the first series of ties, a paved roadway of 75 feet separates the first and second series of railroad ties.

c. The second series of 7 ties are spaced on 8-foot centers and alternately positioned on opposite sides of the road centerline for a distance of 48 feet.

d. The test load is driven across the hazard course at speeds that will produce the most violent vertical and side-to-side rolling reaction obtainable in traversing the hazard course (approximately 5 mph).

2. ROAD TRIP. The test load or vehicle will be transported for a distance of 30 miles over a combination of roads surfaced with gravel, concrete, and asphalt. The test route will include curves, corners, railroad crossings and stops and starts. The test load or vehicle will travel at the maximum speed for the particular road being traversed, except as limited by legal restrictions.

3. PANIC STOPS. During the road trip, the test load or vehicle will be subjected to three (3) full airbrake stops while traveling in the forward direction and one in the reverse direction while traveling down a 7 percent grade. The first three stops are at 5, 10, and 15 mph while the stop in the reverse direction is approximately 5 mph. This testing will not be required if the Rail Impact Test is performed.

4. WASHBOARD COURSE. The test load or vehicle will be driven over the washboard course at a speed that produces the most violent response in the vertical direction.

C. OCEAN-GOING VESSEL TEST. Shipboard Transportation Simulator (Test Method 5). The Shipboard Transportation Simulator (STS) is used for testing loads in 8-foot-wide by 20-foot-long intermodal freight containers. The specimen shall be positioned onto the STS and securely locked in place using the cam lock at each corner. Using the procedure detailed in the operating instructions, the STS shall begin oscillating at an angle of 30 degrees, plus or minus 2 degrees, either side of vertical center and a frequency of 2 cycles-per-

minute (30 seconds, plus or minus 2 seconds) for a duration of two (2) hours. This frequency shall be observed for apparent defects that could cause a safety hazard. The frequency of oscillation shall then be increased to 4 cycles-per-minute (15 seconds, plus or minus one second per cycle) and the apparatus operated for two (2) hours. If an inspection of the load does not indicate an impending failure, the frequency of oscillation shall be further increased to 5 cycles-per-minute (12 seconds, plus or minus one second per cycle), and the apparatus operated for four (4) hours. The operation does not necessarily have to be continuous; however, no changes or adjustments to the load or load restraints shall be permitted at any time during the test. After once being set in place, the test load (specimen) shall not be removed from the apparatus until the test has been completed or is terminated.

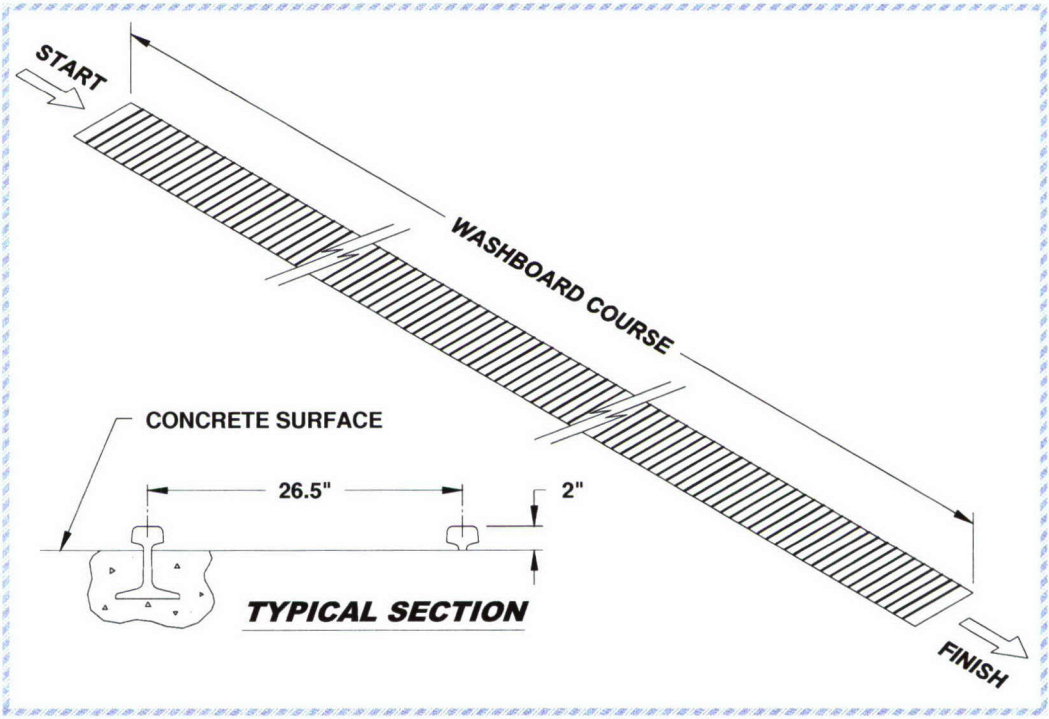

Figure 3. Washboard Course Sketch

PART 5 - TEST RESULTS

5.1

Test Specimen: SEA BOX JMIP in an Intermodal Container.

Payload: 4 BAE JMICs and 1 Navy JMIC.

Testing Date: 17 November 2006

Gross Weight: 16,740 pounds (Including JMIP, interface frames, JMICs and intermodal container).

Note: The pin and locking mechanism to hold the A-frame in the container transport position had been redesigned on the JMIP. The previous design was a pin that engaged a block that was welded to the A-frame (see Photo 1). The new design used a lever operated pin to engage a hole in the A-frame (see Photo 2).

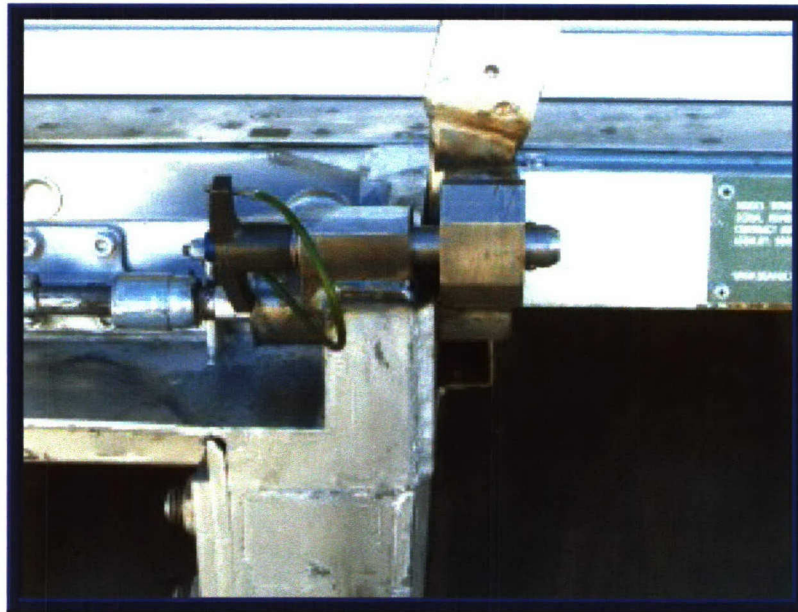

Photo 1. Previous Container Transport Position Pin Design

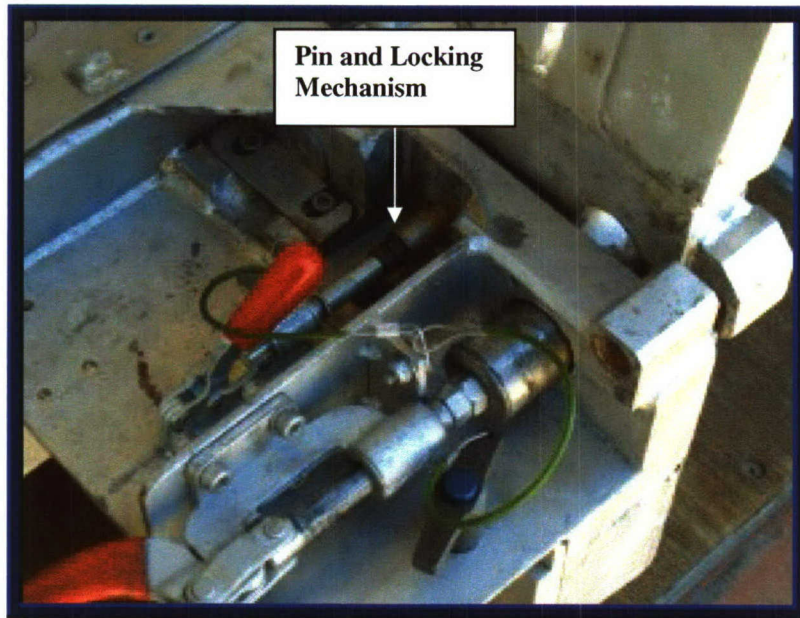

Photo 2. Updated Container Transport Position Pin Design

A. ON/OFF ROAD TESTS.

1. HAZARD COURSE.



Photo 3. Hazard Course Testing of the JMIP in the Intermodal Container.

Pass No.	Elapsed Time	Avg. Velocity (mph)
1	24 Seconds	6
2	24 Seconds	6

Figure 4.

Remarks:

1. Figure 4 lists the average speeds of the test load through the Hazard Course.
2. The adjustment bolts on the cams moved during Passes 1 & 2. The JMIP remained secure in the container.
3. Inspection following the completion of Pass #1 revealed that the JMIP had moved toward the driver's side 0.25 inches.
4. No damage or failure occurred with the pin and locking mechanism that held the A-frame in the container transport position.

2. ROAD TRIP.

Remarks:

1. The Road Trip was conducted between the Road Hazard Course Passes #2 and #3.
2. Inspection following the Road Trip revealed no damage or movement of the JMIP or the pin and locking mechanism.

3. PANIC STOPS.

- a. Inspection following the Panic Stops revealed no damage to the JMIP or the pin and locking mechanism.
- b. Inspection following the 10 MPH panic stop revealed that the JMIP had moved 0.125 inches toward the closed end of the container.

4. HAZARD COURSE.

Pass No.	Elapsed Time	Avg. Velocity (mph)
3	24 Seconds	6
4	25 Seconds	6

Figure 5.

Remarks:

1. Figure 5 lists the average speeds of the test load through the Hazard Course.
2. The adjustment bolts on the cams moved during Passes #3 & #4. The JMIP remained secure in the container. Following Pass #3 one cam was not fully engaged in the container shoring slot. (See Photo 4).
3. Inspection following the Road Trip revealed no damage or movement of the JMIP or the pin and locking mechanism.



Photo 4. Cam not fully engaging shoring slot.

5. WASHBOARD COURSE.

Remark: Inspection following the Road Trip revealed no damage or movement of the JMIP or the pin and locking mechanism.



Photo 5. Washboard Course Testing JMIP.

B. OBSERVATIONS.

1. Some movement of the adjustment bolt on the cams did occur during the testing. The movement of the cam locking bolt was not significant enough to cause excessive movement of the JMIP. Future designs of the cam locking devices should prevent the bolts from moving in or out.

2. The pin and locking mechanism that held the A-frame in the container transport position completed the testing without failure or damage.

C. CONCLUSION. The JMIP, with interface frames, as currently designed, is adequate to be used to transport the Navy JMIP containers with ammunition, on/off road, in an intermodal container during the LMUA.

The maximum gross weight (platform and payload weight) is **not to exceed 15,000 pounds** during the LMUA.

PART 6 – DRAWINGS

The following drawing represents the load configuration that was subjected to the test criteria.

TEST SKETCH

LOADING AND BRACING OF JOINT MODULAR INTERMODAL CONTAIN- ERS (JMICS) ON THE JOINT MODU- LAR INTERMODAL PLATFORM (JMIP)

**THIS EIGHT PAGE DOCUMENT DEPICTS NAVY AND
BAE JMIC PROTOTYPES ON A SEABOX PROTOTYPE
JMIP FOR TRANSPORTABILITY TESTING TO TEST
OF NEW PINS ON BALE ARM**

PREPARED DURING JULY 2006 BY:
U.S. ARMY DEFENSE AMMUNITION CENTER
ATTN: SJMAC-DET
POC: MICHAEL BARTOSIAK
DSN 956-8083
COMM (918) 420-8083
FAX (918) 420-8811
E-MAIL: MICHAEL.BARTOSIAK@US.ARMY.MIL

LAURAA. FIEFFER
CHIEF, TRANSPORTATION ENGINEERING DIVISION

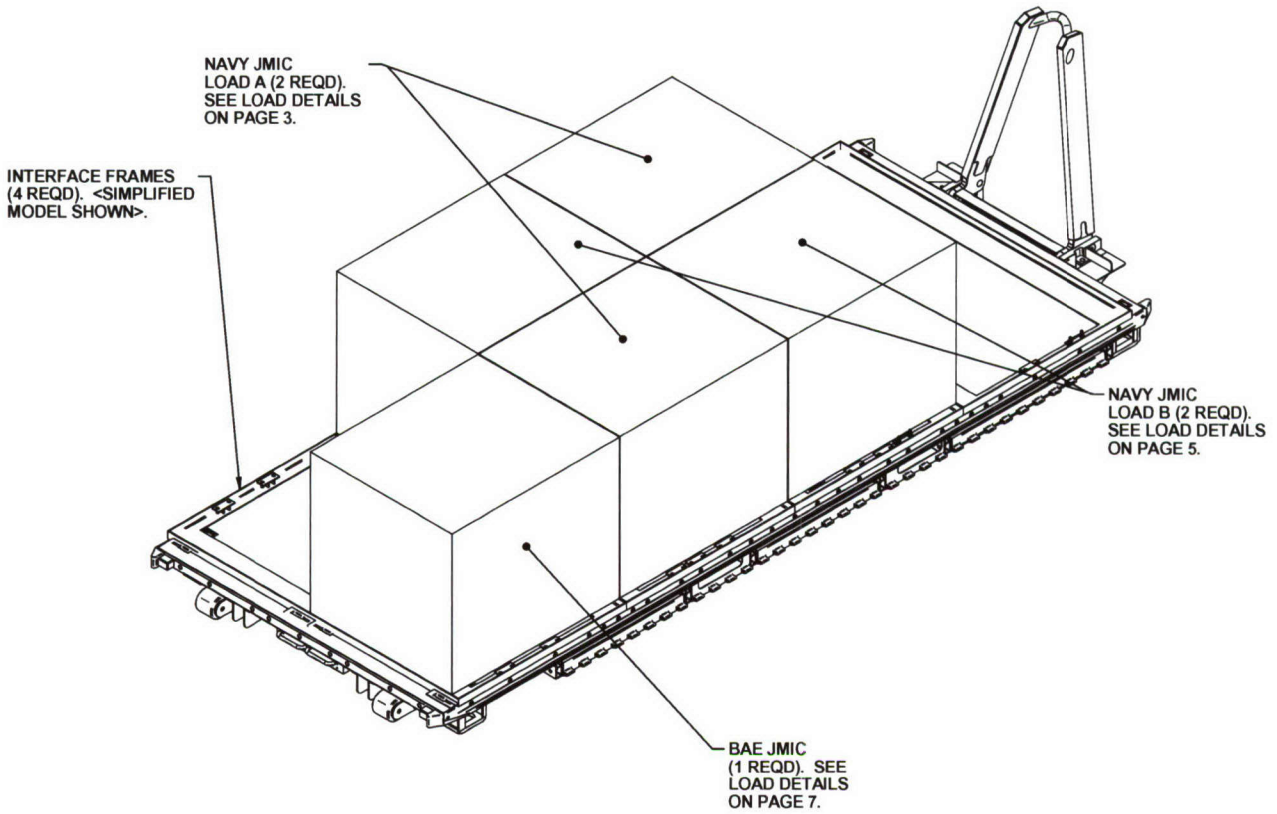

ISOMETRIC VIEW

LOAD AS SHOWN

ITEM	QUANTITY	WEIGHT (APPROX)
NAVY JMIC LOAD A	2	5,942 LBS
NAVY JMIC LOAD B	2	4,728 LBS
BAE JMIC (4 BOXES)	1	909 LBS
INTERFACE FRAMES	4	580 LBS
JMIP		3,950 LBS
TOTAL WEIGHT		16,109 LBS (APPROX)

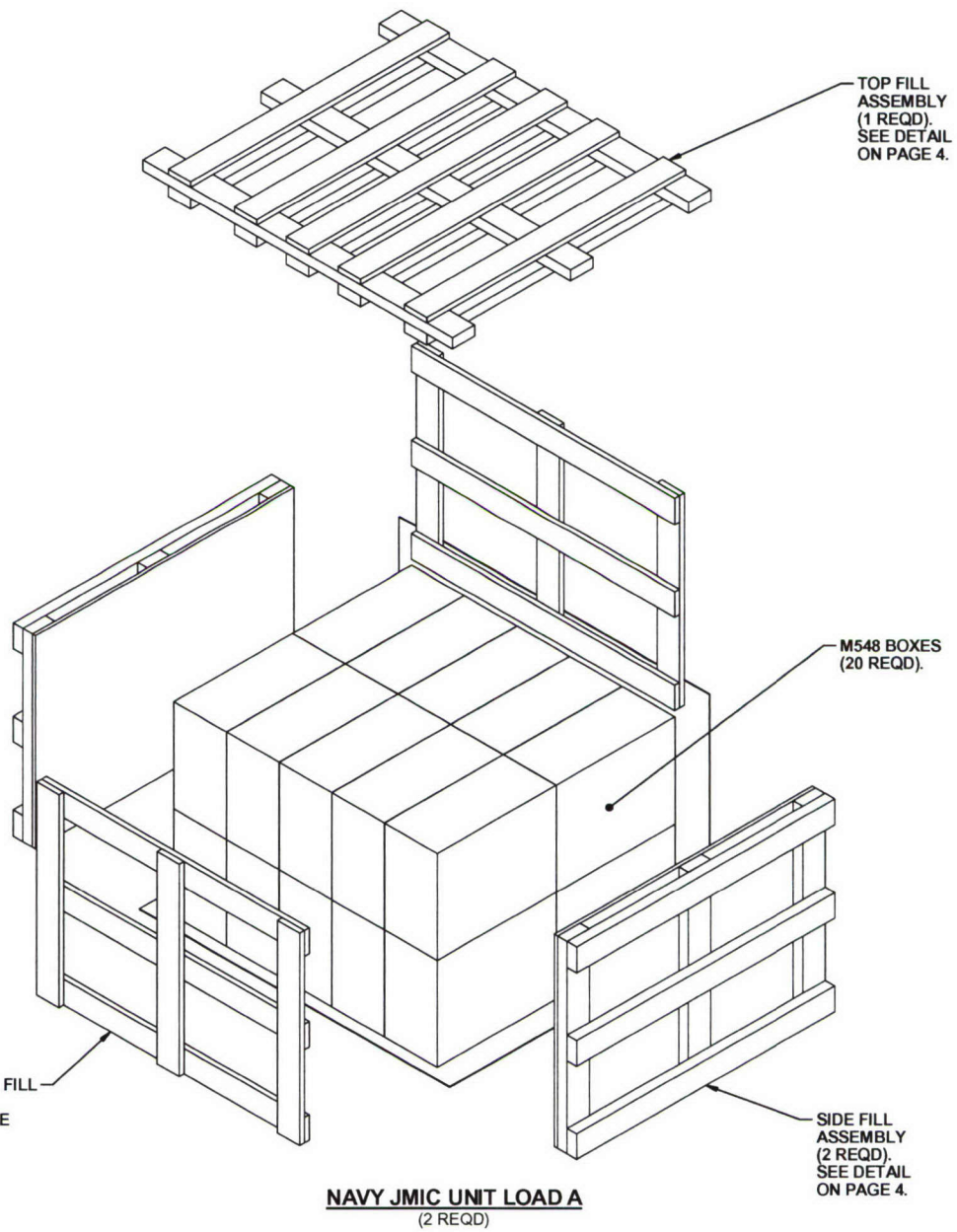

20 M548 BOXES @ 125 LBS - - - - - 2,500 LBS
 DUNNAGE - - - - - 146 LBS
 CLOSED PANEL NAVY JMIC - - - - - 325 LBS

TOTAL WEIGHT - - - - - 2,971 LBS (APPROX)
 CUBE - - - - - 56.4 CU FT (APPROX)

BILL OF MATERIAL		
LUMBER	LINEAR FEET	BOARD FEET
1" X 4"	52	18
2" X 4"	64	43
NAILS	NO. REQD	POUNDS
3d (1-1/4")	84	.16
6d (2")	60	.35
10d (3")	36	.54
NAVY PANEL JMIC - - - - -	1 REQD - - - - -	325 LBS
1/2 PLYWOOD - - - - -	17 SQ FT - - - - -	23 LBS

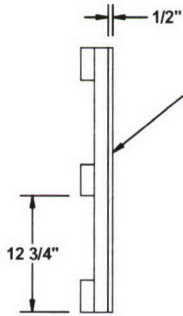
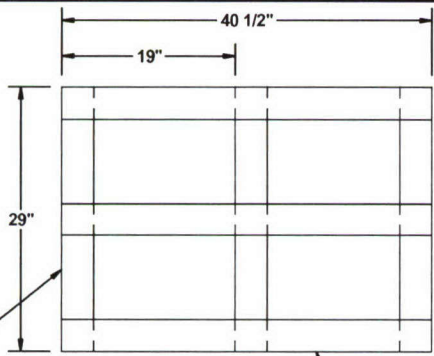

PLYWOOD
40-1/2" X 29" X 1/2"
(1 REQD). NAIL TO
VERTICAL PIECES
W/1-3d NAIL
EVERY 4".

VERTICAL PIECE
2" X 4" X 29"
(3 REQD).

HORIZONTAL PIECE
2" X 4" X 40 1/2"
(3 REQD). NAIL TO
VERTICAL PIECES
W/2-10d NAILS AT
EACH JOINT.

SIDE FILL ASSEMBLY
(2 REQD)

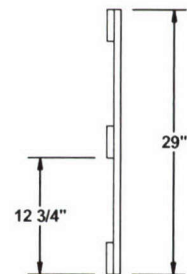
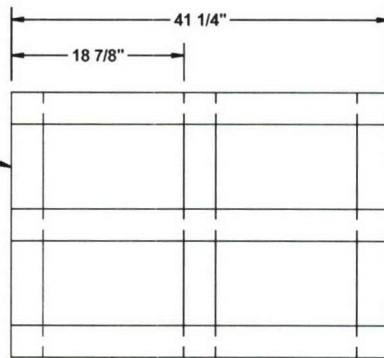

VERTICAL PIECE
1" X 4" X 29"
(3 REQD). NAIL TO
HORIZONTAL PIECES
W/2-3d NAILS AT
EACH JOINT.

HORIZONTAL PIECE
1" X 4" X 41-1/4"
(3 REQD).

FRONT/REAR FILL ASSEMBLY
(2 REQD)

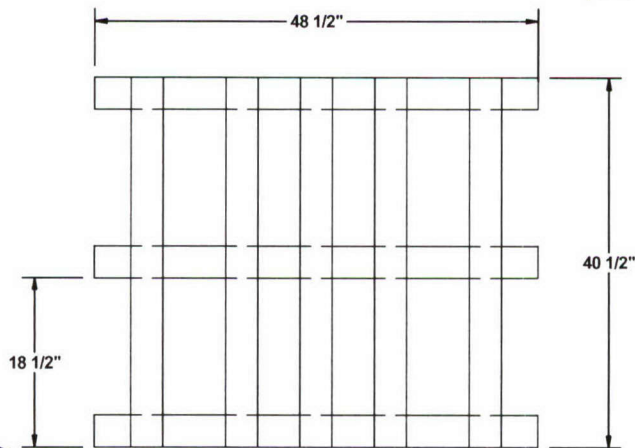

SECONDARY LONGITUDINAL
PIECE, 1" X 4" X 40 1/2"
(5 REQD). NAIL TO LATERAL
PIECES W/2-6d NAILS AT
EACH JOINT.

LATERAL PIECE
2" X 4" X 48-1/2"
(3 REQD). NAIL TO
LONGITUDINAL
PIECES W/2-6d NAILS
AT EACH JOINT.

LONGITUDINAL PIECE
2" X 4" X 40 1/2"
(5 REQD).

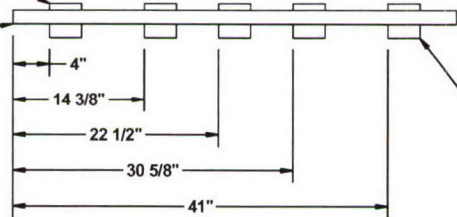

TOP FILL ASSEMBLY
(1 REQD)

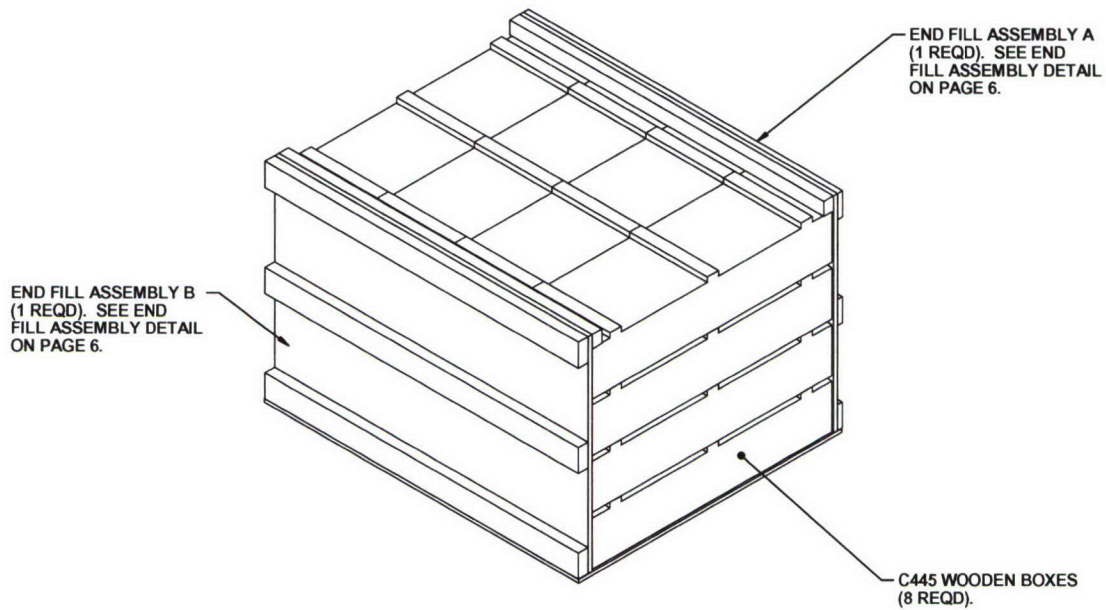

NAVY JMIC LOAD B
(2 REQD)

16 C445 BOXES @ 120 LBS	-----	1,920 LBS
DUNNAGE	-----	119 LBS
NAVY JMIC	-----	325 LBS
<hr/>		
TOTAL WEIGHT	-----	2,364 LBS (APPROX)
CUBE	-----	56.7 CU FT (APPROX)

BILL OF MATERIAL		
LUMBER	LINEAR FEET	BOARD FEET
2" X 4"	65	44
NAILS		POUNDS
6d (2")	60	.35
10d (3")	32	.48
NAVY JMIC	1 REQD	325 LBS
1/2 PLYWOOD	22 SQ FT	30 LBS

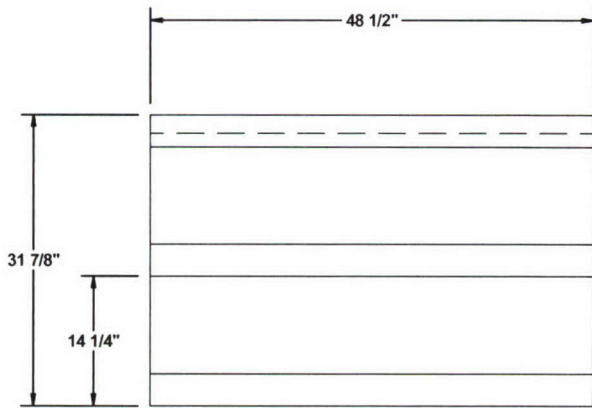

FILL PIECE
2" X 4" X 48-1/2" FOR
ASSEMBLY B.
(FOR ASSEMBLY A
1" X 4" X 48-1/2")
(3 REQD). NAIL TO
PLYWOOD W/1-3d
NAIL EVERY
6 INCHES.

HOLD DOWN PIECE
2" X 2" X 48-1/2"
(1 REQD). NAIL TO
PLYWOOD W/1-3d
NAIL EVERY
6 INCHES.

PLYWOOD
31-7/8" X 48-1/2" X 1/2"
(1 REQD).

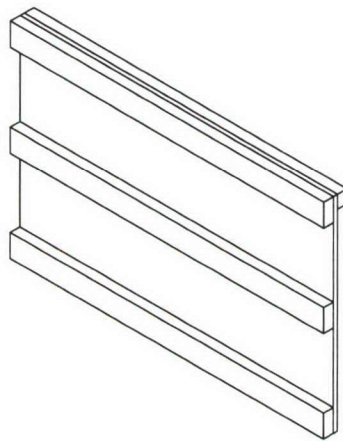

END FILL ASSEMBLY
(ASSEMBLY A - 1 REQD)
(ASSEMBLY B - 1 REQD)

END FILL ASSEMBLIES
(2 REQD). SEE END
FILL ASSEMBLY A DETAIL
ON PAGE 8.

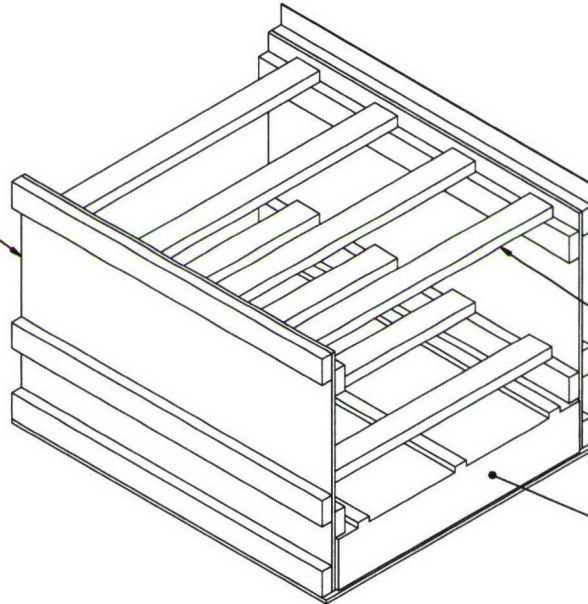

STRUTS, 2" X 4" X
CUT TO FIT (37-11/32 REF)
(8 REQD). NAIL TO LEDGE
PIECES ON END FILL
ASSEMBLIES W/2-10d NAILS
AT EACH JOINT.

C445 WOODEN BOXES
(4 REQD).

BAE JMIC UNIT
(1 REQD)

4 C445 BOXES @ 120 LBS	-----	480 LBS
DUNNAGE	-----	119 LBS
BAE JMIC	-----	310 LBS

TOTAL WEIGHT	-----	907 LBS (APPROX)
CUBE	-----	56.7 CU FT (APPROX)

BILL OF MATERIAL		
LUMBER	LINEAR FEET	BOARD FEET
2" X 4"	65	44
NAILS	NO. REQD	POUNDS
6d (2")	60	.35
10d (3")	32	.48
BAE JMIC	1 REQD	310 LBS
1/2 PLYWOOD	22 SQ FT	30 LBS

