

Retromodulator for Optical Tagging for LEO Consumables

G. C. Gilbreath, Timothy J. Meehan, W. S. Rabinovich, Michael J. Vilcheck, Rita Mahon¹, Mena Ferraro²,
John A. Vasquez, Ilene Sokolsky, D. Scott Katzer, K. Ikossi-Anastasiou, and Peter G. Goetz

Naval Research Laboratory
Washington, DC 20375
202-767-0170
gilbreath@rsd.nrl.navy.mil

Abstract— In this paper, we report the results of a recent demonstration in which a Multiple Quantum Well retromodulator array was used as a low power, lightweight means to provide optical tagging of a remotely located object. A laser diode integrated on a tracker/pointing system scanned without cueing for a modulated retroreflected beam. The retroreflected energy was received and the embedded code demodulated for tagging identification. Ranges were on the order of 40 meters using an array of 1/2 cm MQW devices. Data were transferred at a rate of one mega chip per second over the link. Device power requirements were on the order of several milliwatts.

TABLE OF CONTENTS

1. INTRODUCTION
2. RETROMODULATORS AND MQW DEVICES
3. FIELD TEST
4. RESULTS
5. SUMMARY
6. REFERENCES

1. INTRODUCTION

Future long-range manned NASA missions will require very large reserves of consumables, such as food, and fuel. The cost of launching these consumables into orbit using conventional rocket technology is prohibitive and so alternative methods must be found. A proposed solution to the problem is to launch consumables into space with non-conventional means, such as a rail gun. Once the problem of getting these packages to orbit has been solved a new problem of locating and identifying them arises. These consumables will initially be located in a variety of orbits and it would be necessary to locate them and then aggregate

them into a “warehouse in the sky”. This task would involve finding the consumables, identifying them, and then guiding them to a central warehouse facility.

Modulating retro-reflector systems using Multiple Quantum Well (MQW) technology provide a low power, low weight, multi-functional solution to some of these problems. [1-3] A modulating retro-reflector is a solid-state device that allows optical communication, ranging, and relative orientation determination between two platforms. MQW shutters are particularly suited to these applications because the technology enables fast data rates, requires very low drive powers, is lightweight, robust, and is not polarization-sensitive.

Implementation of such a device requires that only one of the platforms have onboard a laser, telescope, and tracker. Thus, the device is well suited to problems in which one platform has a large payload capacity and can serve as the interrogator and the other platform does not. The interrogator illuminates the platform carrying the modulating retro-reflector with a laser beam. The laser beam is automatically reflected back with no need for pointing or tracking. The reflected return is modulated in an On Off Keying (OOK) mode.

Bi-directional communications can occur if a lower data rate is imposed on the interrogation beam. The modulated retroreflected signal is then received in a burst communications mode. Detectors on the retro-reflector platform can receive the transmitted signal, which may inform the smaller platform of interrogator ID, or location details, etc. These detectors can also receive photonic information which can be used in acquisition and tracking. A representative concept is illustrated in Figure 1.

¹ Author is with Jaycor, Inc., McLean, VA 22102

² Author is with Research Support Instruments, Inc., Lanham, MD 20706

Report Documentation Page

*Form Approved
OMB No. 0704-0188*

Public reporting burden for the collection of information is estimated to average 1 hour per response, including the time for reviewing instructions, searching existing data sources, gathering and maintaining the data needed, and completing and reviewing the collection of information. Send comments regarding this burden estimate or any other aspect of this collection of information, including suggestions for reducing this burden, to Washington Headquarters Services, Directorate for Information Operations and Reports, 1215 Jefferson Davis Highway, Suite 1204, Arlington VA 22202-4302. Respondents should be aware that notwithstanding any other provision of law, no person shall be subject to a penalty for failing to comply with a collection of information if it does not display a currently valid OMB control number.

1. REPORT DATE 2007	2. REPORT TYPE	3. DATES COVERED 00-00-2007 to 00-00-2007			
4. TITLE AND SUBTITLE Retromodulator for Optical Tagging for LEO Consumables		5a. CONTRACT NUMBER			
		5b. GRANT NUMBER			
		5c. PROGRAM ELEMENT NUMBER			
6. AUTHOR(S)		5d. PROJECT NUMBER			
		5e. TASK NUMBER			
		5f. WORK UNIT NUMBER			
7. PERFORMING ORGANIZATION NAME(S) AND ADDRESS(ES) Naval Research Laboratory, 4555 Overlook Avenue, SW, Washington, DC, 20375		8. PERFORMING ORGANIZATION REPORT NUMBER			
9. SPONSORING/MONITORING AGENCY NAME(S) AND ADDRESS(ES)		10. SPONSOR/MONITOR'S ACRONYM(S)			
		11. SPONSOR/MONITOR'S REPORT NUMBER(S)			
12. DISTRIBUTION/AVAILABILITY STATEMENT Approved for public release; distribution unlimited					
13. SUPPLEMENTARY NOTES The original document contains color images.					
14. ABSTRACT					
15. SUBJECT TERMS					
16. SECURITY CLASSIFICATION OF:			17. LIMITATION OF ABSTRACT	18. NUMBER OF PAGES 9	19a. NAME OF RESPONSIBLE PERSON
a. REPORT unclassified	b. ABSTRACT unclassified	c. THIS PAGE unclassified			

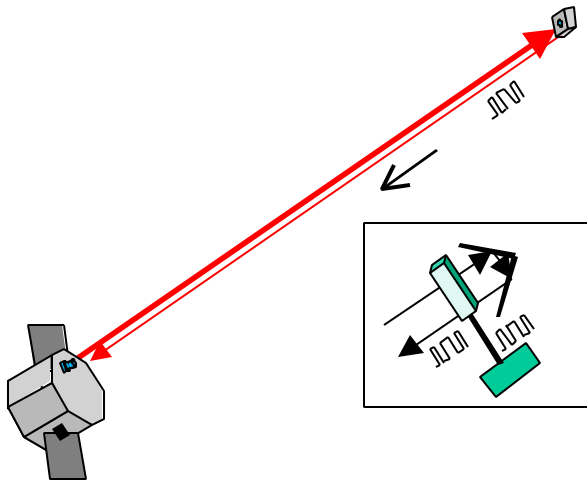

Figure 1. Concept drawing for MQW retromodulators used as ID tags for consumables in orbit. The devices are compact, lightweight, and low power and can serve as transceivers which identify LEO consumable contents as well as aid in acquisition and tracking.

2. RETROMODULATORS AND MQW DEVICES

The Concept

The idea of a retromodulator for communications is not a new one. The concept was successfully demonstrated by the Air Force in 1997 using Ferro Liquid Crystal devices. [4] The concept has also been explored using the Stark effect at 10.6 microns [5] and in the microwave regime [6]. However, these device technologies are inherently slow, can be fragile, and can require high power draws.

Over the past three years, a cross-divisional program at the Naval Research Laboratory (NRL) has demonstrated MQW modulating retro-reflectors with data rates up to 12 Mbps while consuming only about 100 mW of power. In addition, these devices have been used in field tests with a small unmanned airborne vehicle (UAV). In these tests, a ground-based laser tracked the UAV and a modulating retro-reflector optical link was demonstrated. [2] The mounted retromodulator used in this test has about a twenty-degree field-of-view (FOV), full half width maximum. If a modulating retro-reflector system uses an array of corner cubes, this relatively small FOV can be expanded. Such an array can have an arbitrarily large field-of-view while maintaining a very low divergence on the return beam (typically, between 100 and 200 microradians). Thus, a modulating retro-reflector system has the loose pointing tolerances of an omni-directional antenna while still maintaining a very high gain. Such a feature lends itself to a number of applications.

The NRL MQW retroreflector concept is readily adaptable to

the recoverable consumable problem and can be used to (1) uniquely frequency-tag a given “container”; and (2) provide acquisition, rendezvous, and docking. This former point has implications for other problems as well, such as Identification of Friend or Foe (IFF).

MQW Retromodulators

As has been discussed in previously referenced work, the modulator must have several characteristics to make a link possible. The shutter must have a high switching speed, low power consumption, large area, wide FOV, and high optical quality. In addition, it must work at wavelengths where good laser sources are available, be radiation-tolerant (for space applications) and rugged. Semiconductor multiple quantum well modulators are one of the few technologies that meet all these requirements. [7,8] These devices are based upon the same materials technology as laser diodes. They consist of several hundred very thin (~10 nm) layers of semiconductor material, such as GaAs, deposited on a large (7.6 cm diameter) semiconductor wafer. Electrically, they take the form of a P-I-N diode. Optically, the thin layers induce a sharp absorption feature at a wavelength that is determined by the constituent materials and the structure that is grown. When the device has a moderate (~15V) voltage placed across it in reverse bias, the absorption feature changes, both shifting to longer wavelengths and dropping in magnitude. Thus, the transmission of the device near this absorption feature changes dramatically and can serve as an on-off shutter. This switching capability is shown in Figure 2 for an InGaAs-based MQW modulator that was designed and grown for use in a tagging demonstration for Low Earth Orbiting (LEO) spacecraft.

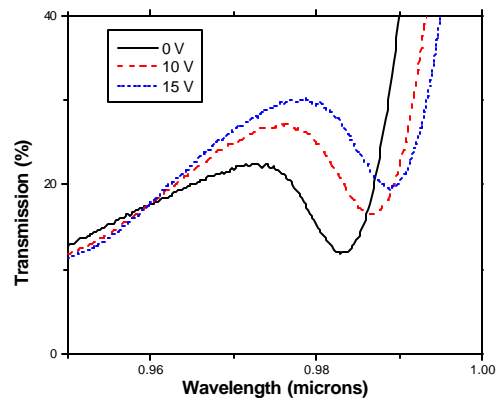

Figure 2. Transmission as a function of wavelength for various applied voltages for an InGaAs-based MQW Modulator

The modulator for this experiment consists of 75 periods of InGaAs wells surrounded by AlGaAs barriers. The device is grown on an n-type GaAs wafer and is capped by a p-type contact layer, thus forming a P-I-N diode. It is a transmissive

modulator designed to work at a wavelength of 980 nm, compatible with many good laser diode sources.

Unlike liquid crystal modulators, MQW modulators have very high switching speeds. Small devices (diameters of microns) have been operated at speeds in the tens of GHz. In practice, the speed is limited primarily by the RC time of the device. Thus, the large area devices (on the order of a centimeter) used for retromodulator-based communications typically have speeds between 1 and 10 Mbps. Higher speeds are possible, however, depending on range and the sophistication of the fabrication process. In practice, data rates like these are appropriate for many of the sensors carried on the small platforms for which these devices are intended.

Robustness

The devices are also extremely robust. They are not polarization-sensitive and except for detuning which can be compensated for using a variety of techniques, are functional over large temperature ranges. Recently, radiation tests were performed on these devices and results are discussed in depth in Reference 9. InGaAs/AlGaAs modulators were characterized optically and electrically and then exposed to a sequence of bombardments of 1MeV protons. One of the devices was irradiated while under a normal operating reverse bias voltage of 15 V; the other devices were unbiased.

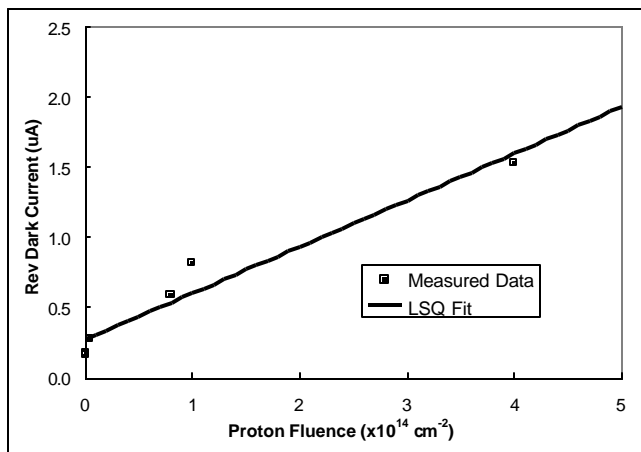

Figure 3 - Reverse leakage current measured at 20V reverse bias after irradiation by increasing 1 MeV proton fluences. The solid line represents a LSQ fit of the data, and the data are seen to increase linearly with fluence.

After each exposure the electronic, optical and modulation characteristics of the modulators were evaluated. No degradation was observed until a cumulative fluence of 1×10^{14} protons/cm², equivalent to an ionizing radiation dose of approximately 200 Mrad(Si). Figure 3 shows some of these results. Table I shows equivalencies in orbit to the fluences tested. As can be seen from these results, there

was no deleterious effect on the devices due to radiation indicating that the MQW shutter will survive in a radiation environment characteristic of Low Earth Orbit (LEO) and Mid Earth Orbit (MEO) for many years.

3. FIELD TEST

The Interrogator

A field test was conducted at the NRL Chesapeake Bay Detachment to demonstrate the concept using a static target and an uncued optical tracker/interrogator. The test simulated a search for one of many packages, each with different tags. For this experiment, a simple optical configuration for the Transmit/Receive (Tx/Rx) interrogator was used. A 100 mW distributed Bragg reflector laser diode operating at 976 nm was fiber-coupled to a lens pair. The beam was given a relatively broad divergence of 3 milliradians to avoid laser safety issues with traffic. The outgoing beam passed through a 7.62 cm diameter 50 percent beam splitter. Half the light went out and half went into a beam dump. This beam splitter to a 5.08 cm diameter lens reflected the retro-reflected light where it was focused onto a silicon avalanche photodiode. A 10 nm bandwidth optical filter was used to remove background sunlight. A 3 MHz

Table I. - Comparison of irradiation with that in Low Earth Orbit

Fluence (cm ⁻²)	Equivalent D _d (MeV/g)	Equivalent number of Years in LEO Orbit
1×10^{11}	5.40×10^9	3.5
8×10^{11}	4.32×10^{10}	28.0
4×10^{12}	2.16×10^{11}	140.2
4×10^{13}	2.16×10^{12}	1402.4
1×10^{14}	5.40×10^{12}	3505.9
4×10^{14}	2.16×10^{13}	14023.6

bandwidth amplifier amplified the resulting signal. The output was read out on an oscilloscope and fed into a computer for matched filter signal correlation and code identification.

The optical assembly was mounted on a motorized gimbal to allow for uncued acquisition of the target. The gimbal was controlled directly with a laptop computer, over an RS232 interface. The laptop set the signal return thresholds to trigger different acquisition modes. It also set the search area. It then commanded the gimbal to work in an automated search pattern to find the target and maximize the return signal. The optics mounted on the gimbal is shown in Figure 4.

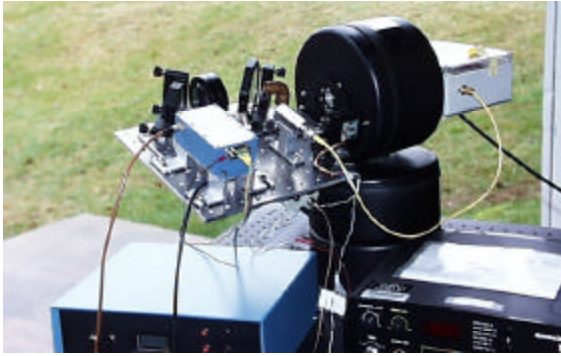

Figure 4. Optical Transmit/Receiver with gimbal.

The receive electronics consisted of an Avalanche Photodiode (APD), amplifier, low pass filter, analog-to-digital converter, Field Programmable Gate Array (FPGA), and computer. The return light was received by the APD, amplified, filtered, and then sampled by the A/D card. The sampled data was then read by the FPGA card that performed the processing described in the next section. The results of the processing were read by the receive computer which archived the data and passed on the levels to the tracking computer over the RS232 link.

The MQWRetromodulator

Five 0.5 mm MQW modulators were arranged in an array for the demonstration. The modulators used had a 75 period InGaAs/AlGaAs MQW structure with an exciton resonance at 981 nm. Each modulator was affixed to a mount centered above a corner-cube retro-reflector. Wire bonds to the p and n contact layers on the modulators were used to bias each device, which were then run in parallel with a prescribed code sequence.

Each retromodulator was mounted in a lightweight, ten-gram package, which was comprised of the holder, the modulator, a 6.33 mm diameter AR coated retro, cover glass window,

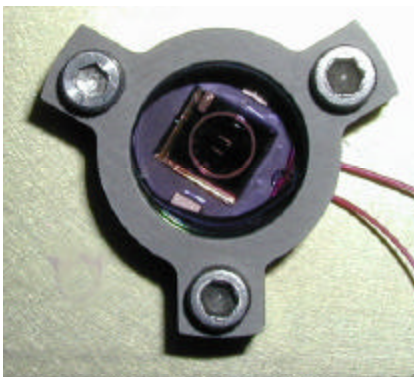

Figure 5. Compact, lightweight mount used in demonstration. Unit is 10g with all parts.

and wire bonds. The FOV of each mounted device was about 30 degrees, dark-to-dark. The devices were arranged into an array to present a 60-degree FOV to the interrogator. A photo of single mounted device is shown in Figure 5.

The modulators used in this demonstration required a ~ 15 Volt swing to achieve a sufficient optical contrast between the on and off states at Mega chip per second rates. Each modulator drew about 75 milliwatts. The five-element array when configured in parallel required about .375 watts. An FPGA was used to encode the data for the driver. FPGA technology was chosen to enable the user to quickly modify encoded data streams, change format, add error correction, etc. Each driver drew about 80 milliwatts for a 0.4 watt total power draw for the array for the drivers only.

The Algorithms

At the heart of the feasibility test were the control algorithms used to identify the signals, correlate gain, control the tracker, and decode the received signals into information. A description of the process has two parts: (1) The tracking algorithm; and (2) the signal received.

The acquisition software initiates a series of ever decreasing rectangular searches based on pre-set threshold levels, t_n . A given swath is painted by the 3 mRad beam and stepped through a given pattern. The gimbal controller receives a relative signal level from the receiver controller and compares the received signal level to the thresholds to command the gimbal through four modes of target acquisition and signal optimization.

As the beam begins to paint the modulator array, the return signal level increases and the next threshold level is reached, initiating the smaller pattern. This continues until a maximum signal level is obtained and the interrogator locks onto the maximum signal. If the signal is lost for some reason, or if the dwell time is too short, after a period, the search pattern “restarts” from the beginning. A hypothetical search pattern is shown in Figure 6.

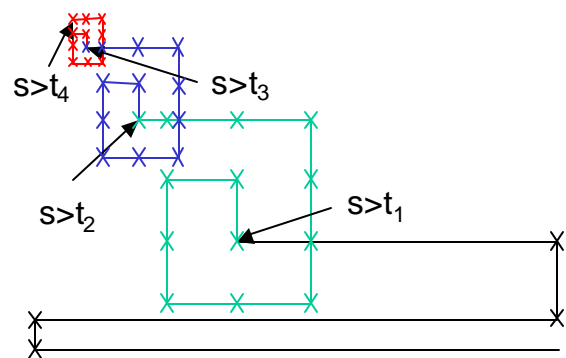

Figure 6. Simulated search pattern is shown above. S denotes signal level, t_n denotes threshold level, and X denotes gimbal stop.

When a signal is received by the photodetector, the receive algorithm processes the bit stream in accordance with the following relationships for the matched filter and envelope detector respectively:

$$s_{(filter)}[n] = c_{(seq)}[n] * s_{(rec)}[n] = \sum_{i=1}^N c_{(seq)}[n-i] \cdot s_{(rec)}[n] \quad (1)$$

$$S_{(out)}(n) = \max(s_{(filter)}[n-k]), \{0 \leq k \leq N\} \quad (2)$$

where: $s_{(filter)}$ is the filtered signal value, $c_{(seq)}$ is the chip sequence which defines a symbol, and $s_{(rec)}$ is the signal received from the APD. N is the product of the number of samples per chip and the number of chips per symbol. A signal level, $S_{(out)}$, is sent to the tracking algorithm when the correlation gain between the received sequence and the matched sequence in the receiver software is maximized for a given tracking position. Figure 7 shows how the above equations are implemented into hardware.

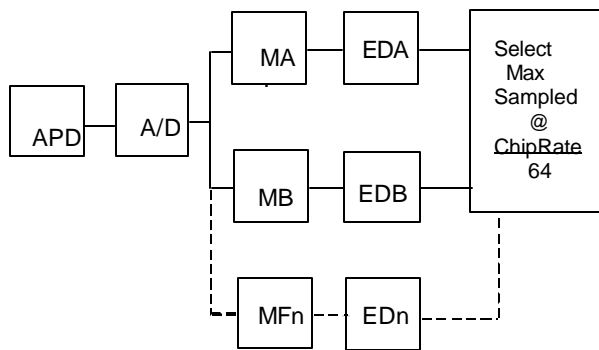

MA, MB, MFn = Matched Filter for Code A, B, ...n
 EDA, EDB, EDn = Envelope Detector for A, B, ...n

Figure 7. Block diagram showing how received signal from the APD is translated into the chip stream used to generate correlation gain for the acquisition sequence and for tag identification.

An important feature in the algorithm set is that more than one bit stream can be processed if each stream is channeled to its own matched filter and envelope detector. This means that more than one identification can be made for (1) discrimination in clutter; or for (2) transmission of additional information with a primary identification tag.

All values for $S_{(out)}$ are sent to the tracker. However, the search algorithm only initiates when the value is greater than a given set threshold as described earlier. When a threshold is exceeded and subsequent tighter patterns are initiated, the target is finally located and identified. If there is more

than one ID sequence, the pattern can be analyzed to determine additional information such as location, contents, received photon level, if a photo detector were put onboard the consumable, etc. Figure 8 is an illustration of the relationship between levels sent and thresholds.

Tests

Two tests were made. Both were conducted at the NRL Chesapeake Bay Detachment in winter months of 2000. The first employed a relatively simple robust data stream of binary F's, i.e.: 111100001111..., transmitted at one Mega chip per second, with 4 samples per chip, 32-chip sequence per symbol. The dwell limit was 32 microseconds and the signal out to the tracking algorithm was sent at about one

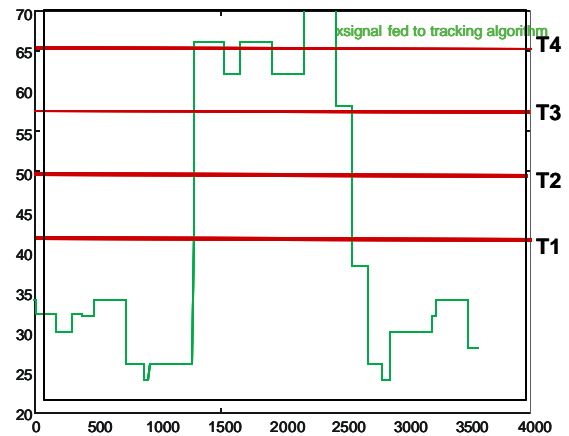

Figure 8. Levels sent from matched filter sequences to tracking controller. All green levels are sent to the controller for acquisition. Only those values above the arbitrarily set thresholds are used to reduce the acquisition pattern area.

kilohertz, limited by the RS232 bandwidth. Laser light was transmitted and data received down a corridor in room light at room temperature to establish a baseline and to more closely replicate propagation conditions in space. Then, laser light was transmitted and modulated light signals received over a range of approximately 43 meters, out of doors, in the daylight. The beam was progressively attenuated to emulate photon levels characteristic of longer ranges.

In the second test, two separate bit streams were sent, characterizing two different ID tags. Again, corridor as well as field data was taken to establish baselines and emulate propagation conditions in space. The two bit streams were generated by two different pseudo random code sequences in 64 chips per symbol sequences with 4 samples per chip. The dwell time was 64 microseconds with a chip transfer rate of one Mega chip per second as before. The two pseudo random code sequences were alternated approximately every ten seconds

4. RESULTS

Test I

In the first test, chip streams were received at a range of approximately 43 meters, out-of-doors, during the daylight. Laser output powers were decreased to observe algorithm response at lower signal levels. Figure 9 is a photograph of the acquisition system and the modulator array in the field.

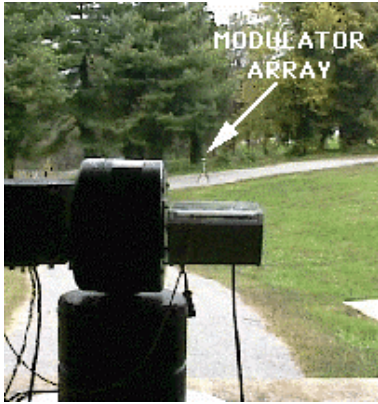

Figure 9. Photo of Tx/Rx and NRL retromodulator array in the field at Chesapeake Bay Detachment.

Representative data from the chip streams recorded using the parameters described is shown in Figure 10. The robust data sequence provided clean signals for the receiver algorithm, even at the lower laser output values. The test showed that the uncued tracker could successfully acquire and lock onto a modulated signal for decreasing levels of photon flux in the presence of sunlight.

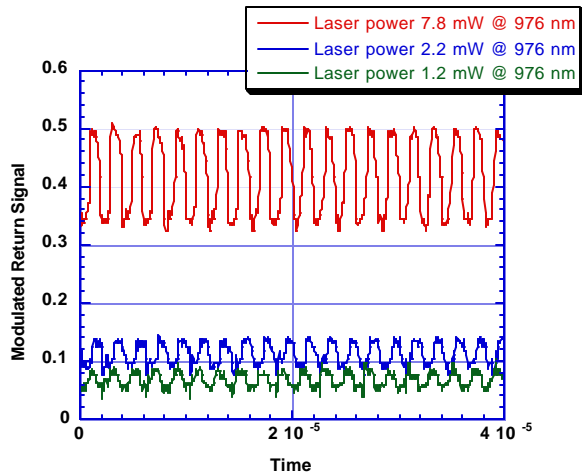

Figure 10. Received data from retromodulator array using MQW modulators for decreasing output laser levels.

Test II

In the second test, two different chip streams were alternately sent to the receiver controller as described

previously. The processed levels were sent to the gimbal controller as well. Again, the output laser power was decreased. The chip streams were more stressing than in the first test as they were generated from pseudo random codes. Consequently, they were potentially more susceptible to scattering. Received chip streams are shown in Figure 11 for 3.6 mW out (30 ma) and 1.1 mW out (15 ma)

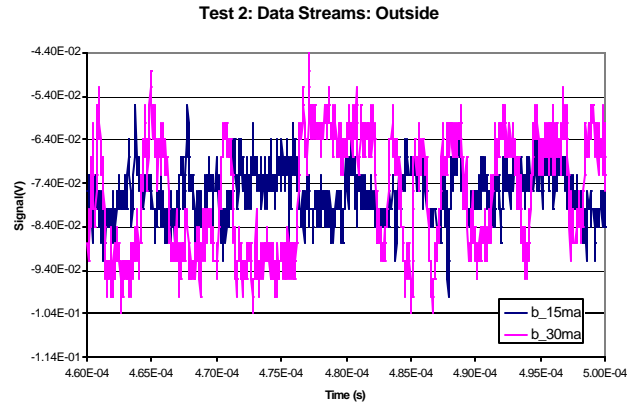

Figure 11. Chip streams received in field test for 1.1 mW laser output (15 mA drive) and 6.4 mW (30 mA).

for the field data obtained in daylight. Considerable scatter in the received bit streams, most likely due to atmospheric turbulence, is apparent even at the higher flux level. The relative levels for the 1.1 mW chip stream is shown in Figure 12. These levels are derived from the chip streams characteristic of those shown in the previous figure. The

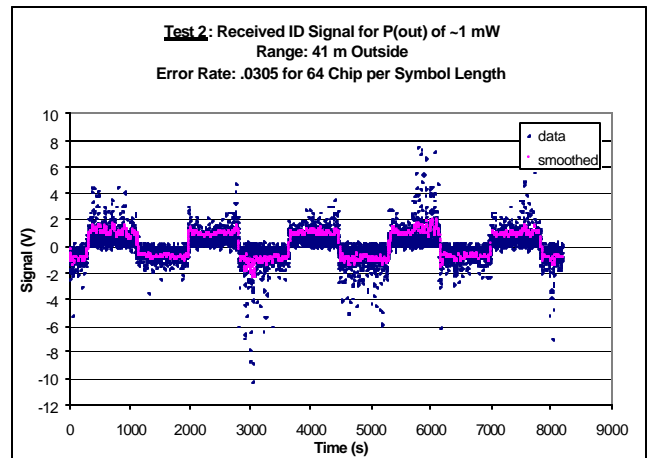

Figure 12. Level sent to gimbal controller from receiver algorithm at lowest output power, outside, during day.

graph in Figure 12 shows the impact of scattering at low light levels (long ranges) on errors, hence, error rate. As can be seen from the figures, the acquisition and tag ID process was robust even at low light levels.

To understand the impact of transmission through a turbulent atmosphere, corridor results were compared to field

results for levels processed for gimbals control. These results can be directly compared to the field data in Figures 11 and 12 and are shown in Figure 13 and 14. The data in these

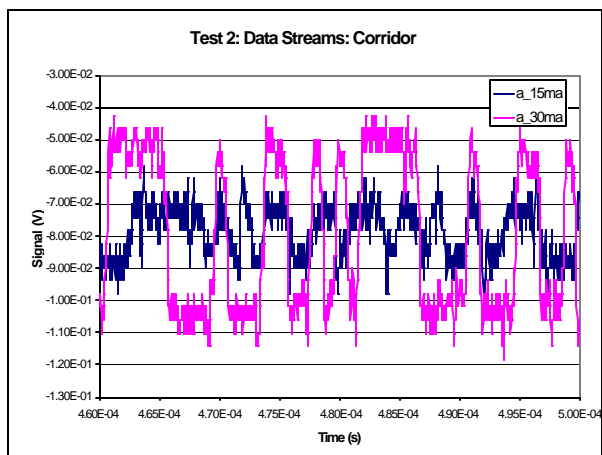

Figure 13. Chip streams received in corridor for 1.1 mW laser output (15 mA drive) and 6.4 mW (30 mA).

figures for the more stressing case of 1.1 mW output power, are interesting because they are characteristic of signals received over a longer range, in the sunlight. The graphs show that even at the low light levels, recovered levels are robust with essentially no errors. Essentially, the inherent “notch” nature of the MQW shutter combined with a

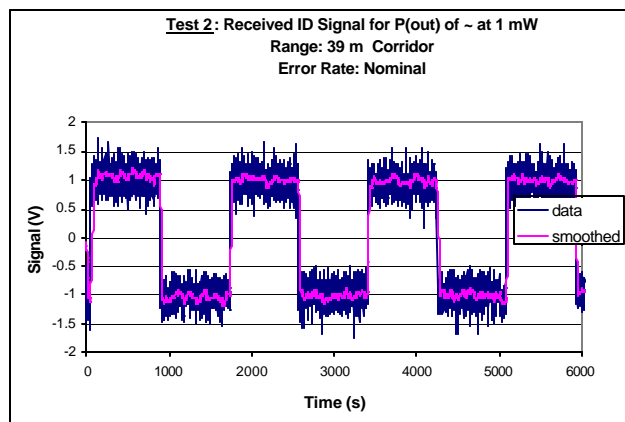

Figure 14. Level sent to gimbal controller from receiver algorithm at lowest output power, down corridor in ambient light.

quiescent propagation channel enable effective data transfer for space applications. As the power received is proportional to the product of the power transmitted times the square of the channel loss, divided by the range to the fourth power, a quiet channel can have an important impact on link closure at longer ranges and/or lower transmit power densities.

Error rates for corridor and field tests are summarized in Table II. Errors of one or less for a 64-bit word were counted as "nominal". It is clear from this table that turbulence has

Table II. Errors and Error Rates Compared

P(out)	Corridor			Field
(mW)	Errors	Error Rate	Errors	Error Rate
6.8	(Nominal)	---	(Nominal)	---
5.2	(Nominal)	---	(Nominal)	---
4.4	(Nominal)	---		
3.6	(Nominal)	---	(Nominal)	---
1.9	(Nominal)	---	(Nominal)	---
1.5			154	0.012533
1.3			250	0.030518
1.1	(Nominal)	---	1044	0.10923
0.97			1804	0.17617
0.94	517	0.094654		
0.794	516	0.15114		

an impact on effectively longer range acquisition. However, in space, where this is not a factor, the comparative output powers can maintain a link at longer ranges for acquisition and tag identification with nominal errors.

5. SUMMARY

In this paper, results have been reported which demonstrate how a Multiple Quantum Well retromodulator can be effectively used as an identification tag for remotely located consumables. Modulated, retroreflected laser light was received and processed to provide levels for acquisition algorithms. These levels were established through a discrete convolution of the received chip sequence. Thresholds were set by the acquisition software to use the levels to search for the consumable in ever decreasing rectangular patterns.

Data was obtained from field tests at the NRL Chesapeake Bay Detachment. Chip streams were obtained at rates of one megachip per second over ranges on the order of 40 meters. Baselines were established from propagation down a corridor for comparable ranges and compared to results taken from field tests out doors in daylight.

When two sequences were alternatively sent and demodulated, the process demonstrated that a tag could be identified out of a crowded environment. The method also demonstrated that additional information, such as geolocation, photonics, or container content, could be sent with alternating data streams without affecting acquisition efficacy.

MQW retromodulators are particularly useful as they can support faster data rates, hence longer ranges, at lower powers than other devices presently on the market. Recent radiation tests also indicate considerable robustness for space applications.

6. REFERENCES

- [1] G.C. Gilbreath, S.R. Bowman, W.S. Rabinovich, C.H. Merk, H.E. Senasack, "Modulating Retroreflector Using Multiple Quantum Well Technology", U.S. Patent No. 6,154,299, awarded November, 2000.
- [2] G. C. Gilbreath, W. S. Rabinovich, T. J. Meehan, M. J. Vilcheck, R. Mahon, Ray Burris, M. Ferraro, I. Sokolsky, J. A. Vasquez, C. S. Bovais, K. Cochrell, K. C. Goins, R. Barbehenn, D. S. Katzer, K. Ikossi-Anastasiou, and Marcos J. Montes, "Compact, Lightweight Payload for Covert Data Link using a Multiple Quantum Well Modulating Retroreflector on a Small Rotary-Wing Unmanned Airborne Vehicle," *SPIE Annual Meeting Proceedings*, **4127**, pp. 57-67, 2000.
- [3] D.S. Katzer, W.S. Rabinovich, K. Ikossi-Anastasiou, and G.C. Gilbreath, "Optimization of buffer layers for InGaAs/AlGaAs PIN optical modulators grown on GaAs substrates by molecular beam epitaxy", *J. Vac. Sci. Technol. B* **18**, pp. 1609-1613 (2000).
- [4] Charles M. Swenson, Clark A. Steed, Imelda A. A. DeLaRue, and Robert Q. Fugate, *SPIE Proceedings*, **2290**, pp. 296-310, 1997.
- [5] M. B. Klein and R. H. Sipman, "Large Aperture Stark Modulated Retroreflector at 10.8 μm ", *J. Appl. Phys.* **51**, pp. 6101-6104 (1980).
- [6] Gordon E. Peckham and Robert A. Suttie, "Microwave Reflection Properties of a Rotating Corrugated Metallic Plate Used as a Reflection Modulator", *IEEE Trans on Antennas and Propagation*, **36**, pp. 1000-1006 (1988).
- [7] W. S. Rabinovich, S. R. Bowman, D. S. Katzer, and C. S. Kyono, "Intrinsic multiple quantum well spatial light modulators", *Appl. Phys. Lett.* **66**, pp. 1044-1046 (1995).
- [8] C. S. Kyono, K. Ikossi-Anastasiou, W. S. Rabinovich, S. R. Bowman, D. S. Katzer, and A. J. Tsao, "GaAs/AlGaAs multiquantum well resonant photorefractive devices fabricated using epitaxial lift-off," *Applied Physics Letters* **64** (17), pp. 2244-2246, 25 April 1994.
- [9] Peter G. Goetz, W. S. Rabinovich, Robert J. Walters, Scott R. Messenger, G. Charmaine Gilbreath, Rita Mahon, M. Ferraro, Kiki Ikossi-Anastasiou, and D. Scott Katzer, "Effects of Proton Irradiation on InGaAs/AlGaAs Multiple Quantum Well Modulators", *Proceedings of IEEE Aerosense Conference*, Paper No. 470, March, 2001.

Dr. G. Charmaine Gilbreath received her B. S. in Physics from Georgia Institute of Technology in 1982, her MSE in

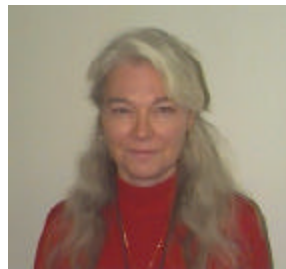

Electrical Engineering and Ph.D. from The Johns Hopkins University in 1986 and 1989, respectively. She has been with the Naval Research Laboratory since 1982. Her specialties are in nonlinear optics, free space optical data transfer, and optical device development. She is the Lead Principal Investigator for NRL's MQW retromodulator programs.

Timothy J. Meehan received his BSEE from the University of Maryland in 1996 and his MSEE from The Johns Hopkins University in 2000. He has been with the Naval Research Laboratory since 1993 where he came as an engineering coop. He joined the permanent staff as electrical engineer in 1996. He is the electronics lead for the MQW modulating retroreflector program.



Dr. William S. Rabinovich received the B. S. in Physics from State University of New York at Stony Brook in 1982 and the MS and Ph.D. degrees, also in Physics, from Brown University, in 1984 and 1987, respectively. He has been with the Naval Research Laboratory since 1987, starting as a Postdoctoral Associate. He is presently the Head of the Photonics Materials and Devices Section and is the co-PI for the MQW modulating retroreflector program at NRL.

Michael J. Vilcheck graduated from Allegheny College with a BS degree in physics. He joined NRL as a coope in 1997 and became permanent with the Electro-Optics Technology Section in 1999. He is currently working toward a MS degree in Mechanical Engineering at the University of Maryland. He is the optical tracker lead for the MQW modulating retroreflector program.



Rita Mahon received the B.Sc. and the Ph.D. degrees in Physics from Imperial College at the University of London in 1970 and 1973, respectively. She did postdoctoral research at York University in Toronto followed by a research associate position in Plasma Physics at the University of Maryland College Park. She works in the Photonics Technology branch of the Optical Science Division at NRL under contract with Jaycor.



Mena Ferraro received the B.S. in Aerospace Engineering and B.S. in Applied Physics from Illinois Institute of Technology in Chicago, IL in 1995. She works in the Electro-Optics Technology section of the Space Systems Development Department at the Naval Research Laboratory under contract with RSI, Inc.

John Vasquez received his B.S. in aerospace engineering in 1997 from the University of Cincinnati. He joined NRL as a coop in 1994 and became permanent in 1997. His specialty is mechanical design and he works in the Spacecraft Engineering Department

Ilene Sokolsky received B.S. in mechanical engineering in 1996 from the University of Maryland. She joined NRL in 1997 as a contractor and became a permanent staff in 1999. Her specialty is in structural analysis and she is the mechanical engineering lead on the MQWQ retro modulator program.

D. Scott Katzer received the B.A. degree in physics from the University of Chicago in 1983, and the Ph.D. in solid-state electronics from the University of Cincinnati, in 1988. In 1989, he joined the Naval Research Laboratory, as an Office of Naval Technology Postdoctoral Fellow. Since 1991, he has been an Electronics Engineer in the High Frequency Devices and Materials Section of the Microwave Technology Branch at the NRL.

Kiki Ikossi received the B.S. in Electrical Engineering from the National Technical University of Athens, Greece in 1977 and M.S. and Ph.D. degree in Electrical Engineering from the University of Cincinnati in 1982 and 1986, respectively. In 1998, she joined the Naval Research Laboratory. She has worked optoelectronic devices, MQW modulators, resonant tunneling diodes, photovoltaic cells, non-destructive electrical characterization techniques and Deep Level Transient Spectroscopy. She is the fabrication lead in the MQW retro modulator program.

Peter G. Goetz received the BSEE from the University of Maryland, in 1988. He received the M.S.E. and Ph.D. degrees in electrical engineering from the University of Michigan, in 1996 and 1998, respectively. In 1999, he joined the Photonics Technology Branch at the NRL, where he has worked in the fields of large-area, low-power multiple quantum well modulating retroreflectors for free space optical communication as well as high current photodiodes.

