

Copyright 2006 Society of Photo-Optical Instrumentation Engineers. This paper was (will be) published in Advances in Stellar Interferometry, SPIE and is made available as an electronic reprint Proc. 6268 with permission of SPIE. One print or electronic copy may be made for personal use only. Systematic or multiple reproduction, distribution to multiple locations via electronic or other means, duplication of any material in this paper for a fee or for commercial purposes, or modification of the content of the paper are prohibited.

Report Documentation Page

Form Approved
OMB No. 0704-0188

Public reporting burden for the collection of information is estimated to average 1 hour per response, including the time for reviewing instructions, searching existing data sources, gathering and maintaining the data needed, and completing and reviewing the collection of information. Send comments regarding this burden estimate or any other aspect of this collection of information, including suggestions for reducing this burden, to Washington Headquarters Services, Directorate for Information Operations and Reports, 1215 Jefferson Davis Highway, Suite 1204, Arlington VA 22202-4302. Respondents should be aware that notwithstanding any other provision of law, no person shall be subject to a penalty for failing to comply with a collection of information if it does not display a currently valid OMB control number.

1. REPORT DATE 2006		2. REPORT TYPE		3. DATES COVERED 00-00-2006 to 00-00-2006	
4. TITLE AND SUBTITLE Engineering overview of the conceptual design and hardware/software implementation proposed for the Magdalena Ridge Observatory Interferometer				5a. CONTRACT NUMBER	
				5b. GRANT NUMBER	
				5c. PROGRAM ELEMENT NUMBER	
6. AUTHOR(S)				5d. PROJECT NUMBER	
				5e. TASK NUMBER	
				5f. WORK UNIT NUMBER	
7. PERFORMING ORGANIZATION NAME(S) AND ADDRESS(ES) New Mexico Institute of Mining and Technology, Magdalena Ridge Observatory, 801 Leroy Place, Socorro, NM, 87801				8. PERFORMING ORGANIZATION REPORT NUMBER	
9. SPONSORING/MONITORING AGENCY NAME(S) AND ADDRESS(ES)				10. SPONSOR/MONITOR'S ACRONYM(S)	
				11. SPONSOR/MONITOR'S REPORT NUMBER(S)	
12. DISTRIBUTION/AVAILABILITY STATEMENT Approved for public release; distribution unlimited					
13. SUPPLEMENTARY NOTES The original document contains color images.					
14. ABSTRACT					
15. SUBJECT TERMS					
16. SECURITY CLASSIFICATION OF:			17. LIMITATION OF ABSTRACT	18. NUMBER OF PAGES 12	19a. NAME OF RESPONSIBLE PERSON
a. REPORT unclassified	b. ABSTRACT unclassified	c. THIS PAGE unclassified			

Engineering overview of the conceptual design and hardware/software implementation proposed for the Magdalena Ridge Observatory Interferometer

Chethan Parameswariah¹, Eric Bakker¹, David Buscher², Tom Coleman¹, Michelle Creech-Eakman¹, Chris Haniff², Colby Jurgenson¹, Dan KlingleSmith¹, John Young²

1) Magdalena Ridge Observatory, New Mexico Institute of Mining and Technology,
801 Leroy Place, Socorro, NM 87801.

2) University of Cambridge, Cambridge, UK

ABSTRACT

Magdalena Ridge Observatory (MRO) Interferometer is a ten telescope optical interferometer array being built on the Magdalena Mountains 20 miles west of Socorro, New Mexico. The interferometer is being designed by collaboration between New Mexico Institute of Mining and Technology and the University of Cambridge. The science mission and requirements have been finalized which has helped to begin engineering design and development culminating in detailed conceptual designs. Some of the proposed hardware and software implementations are currently being tested in the lab. We present an engineering overview of the conceptual design and the proposed hardware and software implementations.

Keywords: Interferometer, Magdalena Ridge Observatory, MRO, MROI, Conceptual Design, implementation, hardware, software.

1. INTRODUCTION

The Magdalena Ridge Observatory Interferometer - a 10-element optical and near-infrared model-independent imaging interferometer, due for first light in 2008, is being built on the Magdalena Mountains, about 45 minutes west of Socorro, NM at 10,500 feet. The interferometer is being designed by collaboration between New Mexico Institute of Mining and Technology and the University of Cambridge. Section 2 describes the location of the observatory. We present in section 3 an engineering overview of the conceptual design for the whole of the interferometer array and its various sub-systems. Section 3.1 shows the overall control architecture and how various sub-systems of the interferometer are interfaced with each other. In section 3.2 through 3.9 we present the development work to date on the engineering conceptual designs for various sub systems starting from the Unit Telescopes and working our way into the beam combining area. We also present in section 4 an overview of some of the hardware and software implementations are currently being proposed. Section 4.1 discusses the proposed interfacing architecture implementation plan for the conventional facilities such as HVAC system, vacuum pumps, compressors etc. Section 4.2 presents the computer infrastructure plan for the observatory with a view to accommodate general users,

observatory operators and astronomers and data analysts. Sections 4.3 and 4.4 talk about the real-time distributed control hardware and software implementation plans.

2. OBSERVATORY LOCATION

The Magdalena Ridge Observatory (MRO) is located in the Magdalena Mountains 20 miles west of Socorro, New Mexico. The facility will consist of two separate telescope systems: the MRO Single Telescope (MROST) will be a 2.4-meter fast-tracking telescope and the MRO Interferometer (MROI) will consist of 10 1.4-meter telescopes having baselines of up to 400 meters and working in the optical and near-infrared (NIR)[1]. The MROST will be located at the northern end of Magdalena Ridge at an elevation of 10,600 feet (3,230 meters) and the MROI will be located approximately 3,000 feet south at an elevation of 10,450 feet (3,185 meters).

3. ENGINEERING CONCEPTUAL DESIGN OVERVIEW

Science Mission and design requirements for the 10 relocatable telescope MRO Interferometer with baselines up to 400m have been finalized. This has led to further design and development of the interferometer with application of engineering design and concepts. The latest status update on the MRO Interferometer is presented in [1].

Site and Infrastructure design as well as conceptual engineering designs have been completed for the MROI building containing the Beam Combining Area (BCA), Delay Line Area (DLA) and the Interferometer Control Area (ICA). The designs for the buildings and the site infrastructure have progressed to construction ready documents with construction scheduled to start soon.

3.1 OVERALL CONTROL ARCHITECTURE CONCEPTUAL DESIGN

Conceptual hardware and software designs with control architecture have been produced for the whole array with 10 telescopes. Figure 2 shows the overall control architecture conceptual design with ten telescopes, beam relay, delay line, metrology, alignment, beam compressor, beam turning, switchyard, optical tables (only two of four shown), beam combiners, detectors etc are interfaced with each other.

Ten telescopes are shown with three on each of the three interferometer array arms and one central telescope. The beam relay mirrors, alignment components and other systems in the vacuum cans near the telescopes will be controlled by the computers in the unit telescopes while the central telescope computers will also control the components at the vertex.

The architecture shows fast communication links between the delay line carriage, metrology computers and the fringe tracker.

MRO
Magdalena Ridge Observatory
MRO Interferometer

Not To Scale
INT-409-ENG-0003 rev 0.2
Chethan Parameswariah
cparames@mro.nmt.edu

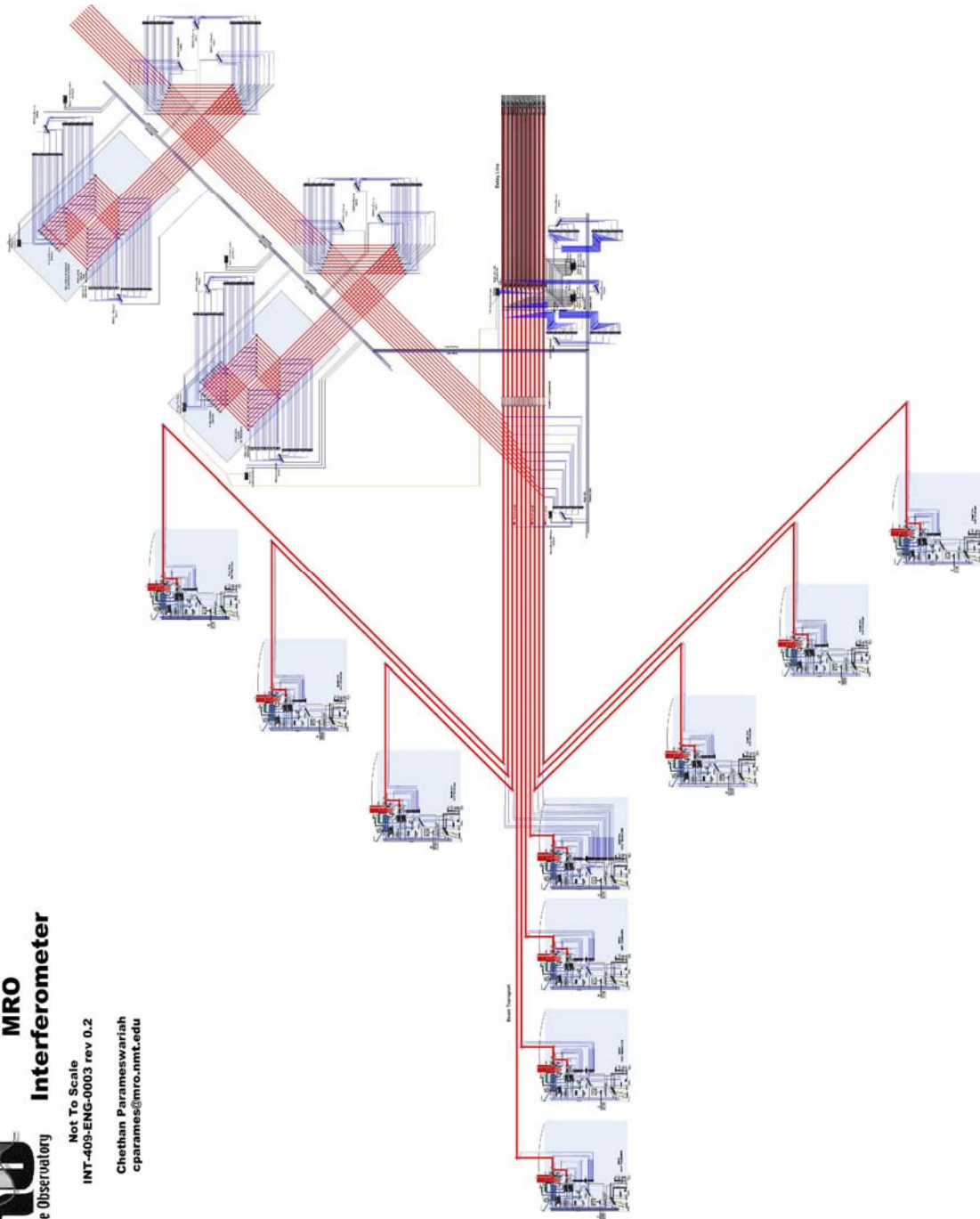

Figure 2: Overall control architecture conceptual design showing how various MROI sub-systems such as the telescopes, beam relay, beam compressor, delay line, switchyard, beam combiners, detectors are interfaced with each other.

3.2 UNIT TELESCOPE CONTROL ARCHITECTURE CONCEPTUAL DESIGN

The Unit Telescopes (UT) along with the Unit Telescope Control System (UTCS) will be vendor supplied with the remaining components such as the fast tip-tilt/narrow angle acquisition camera, wide field acquisition camera, atmospheric dispersion corrector and parts of the Interferometer Control System (ICS) which interfaces with the UTCS, designed and built in-house. The conceptual control architecture for the unit telescopes of the interferometer is shown in figure 3.

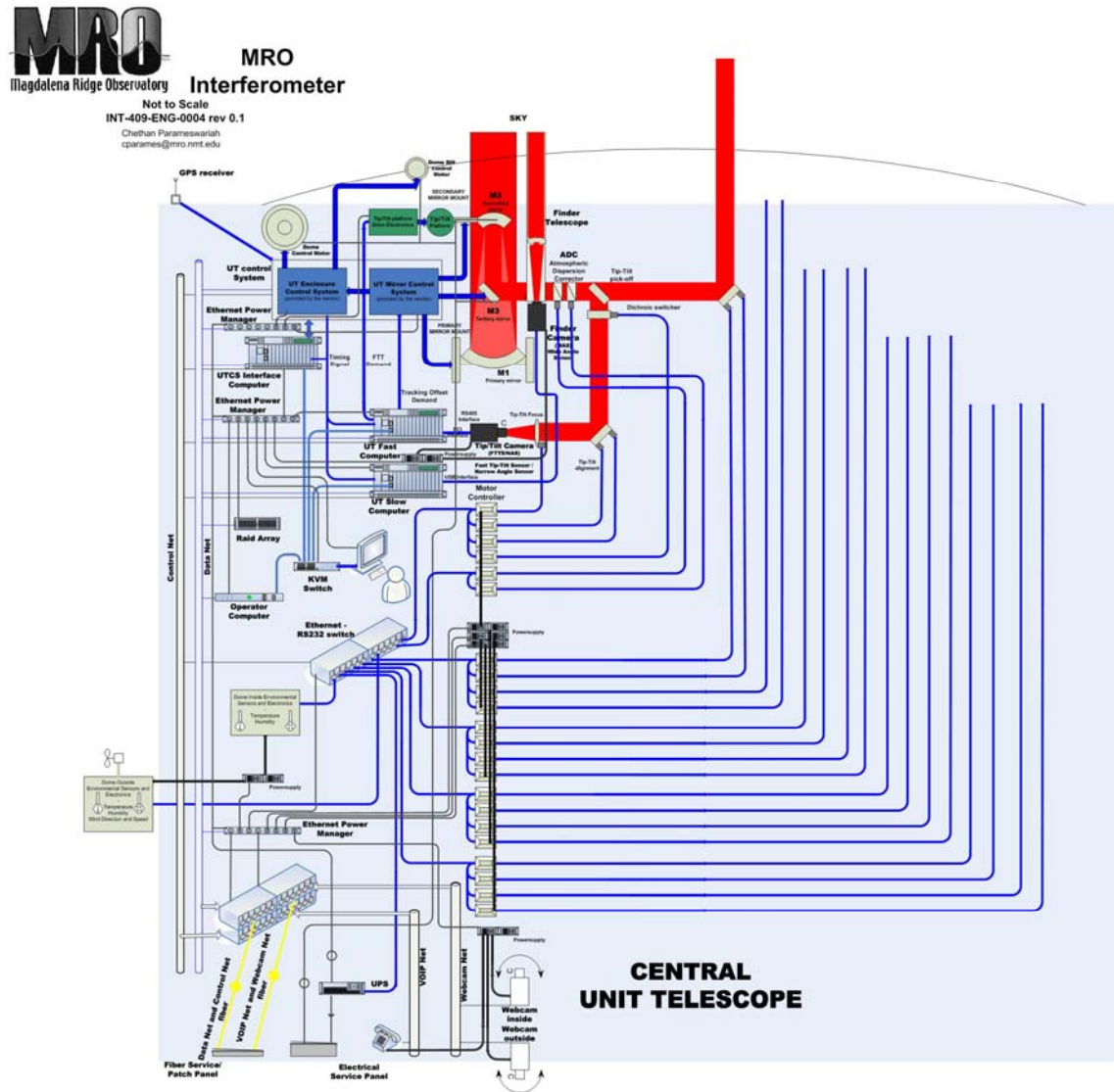

Figure 3: Overall UT control architecture conceptual design showing various components of the UT control system, fast tip-tilt camera and wide field acquisition camera, auxiliary control systems.

3.2 BEAM RELAY SYSTEM COMPONENTS CONCEPTUAL DESIGN

The beam relay system design consists of vacuum pipes, pipe supports, vacuum cans at the UT junctions and the cans at the vertex. Engineering designs looking at alternate concepts are being studied for their cost and structural impact. Figure 4 shows some of the basic conceptual designs being looked at for the beam relay system.

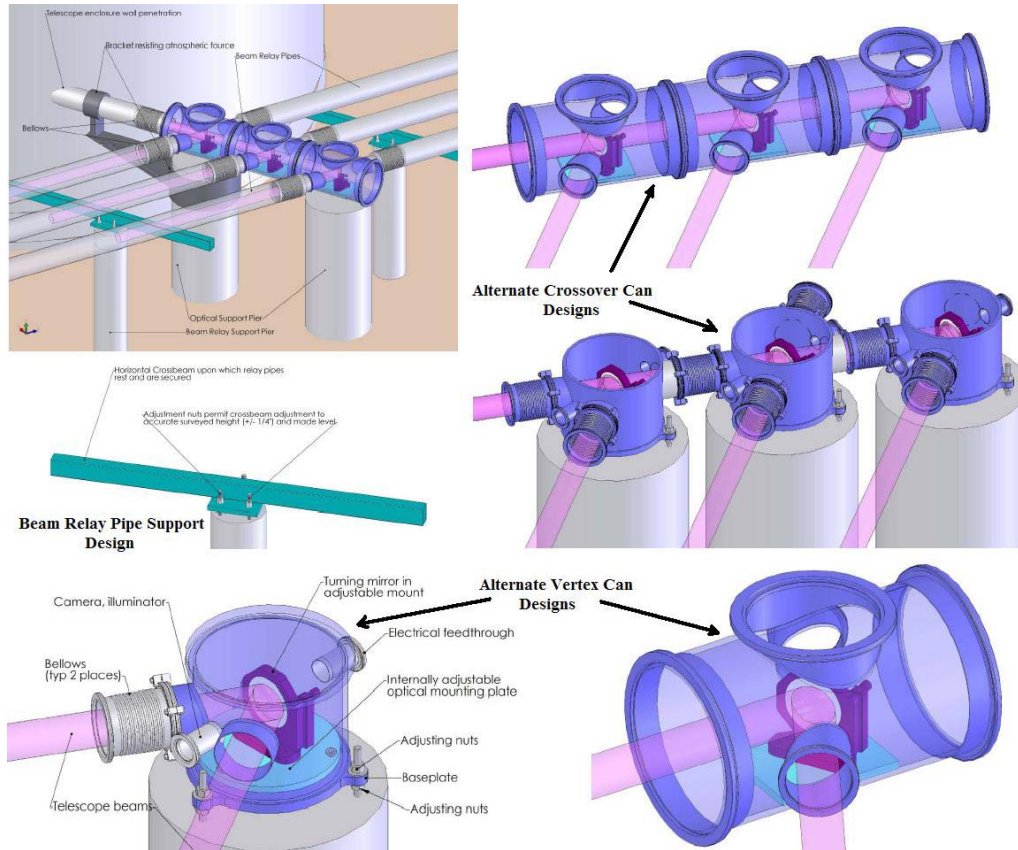

Figure 4: Beam Relay System Conceptual Design showing pipe support design, alternate designs for the crossover cans and the vertex cans.

3.3 DELAY LINE SYSTEM CONCEPTUAL DESIGN

The 190m long delay line system will be a joint effort between the two collaborating universities with the delay line cart effort led by University of Cambridge and the delay pipes and pipe supports built at New Mexico Tech. A paper on the status of the MROI delay line is also presented during this conference [2]. The delay line prototyping effort has begun from initial designs.

The metrology and shear sensing system for the long delay line system is being designed for the interferometer. The initial conceptual design of the control system architecture for the metrology and shear sensing system is shown in figure 5.

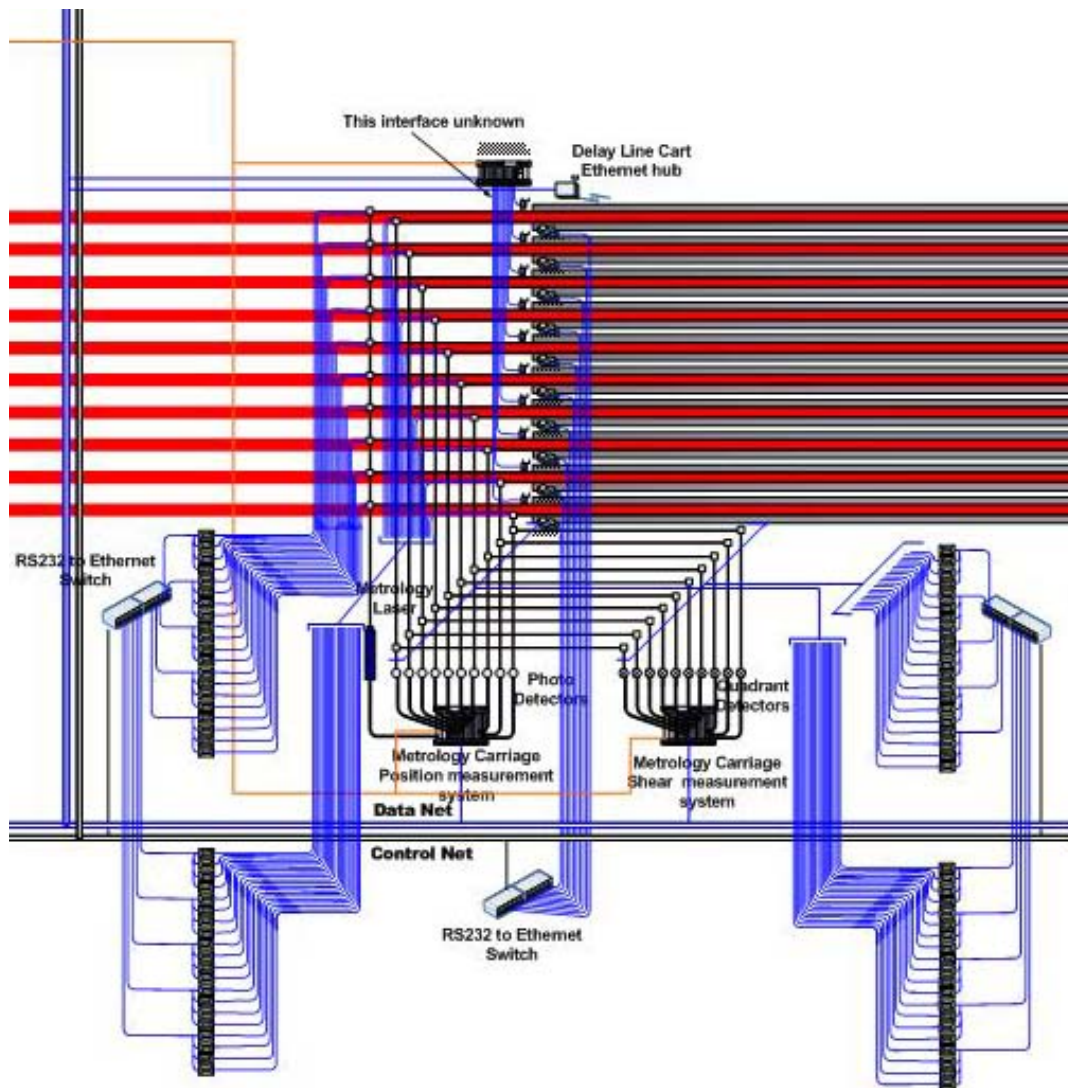

Figure 5: Metrology and Shear sensor system control architecture conceptual design showing the metrology and quadrant detectors along with other metrology beam alignment optics.

3.4 BEAM COMPRESSOR DESIGN

The conceptual beam compressor design to reduce the 95 mm telescope beam to a smaller beam size of 13mm inside the BCA is shown in figure 6. The design shows two parabolic mirrors located inside the rectangular structure with focus and height adjustments.

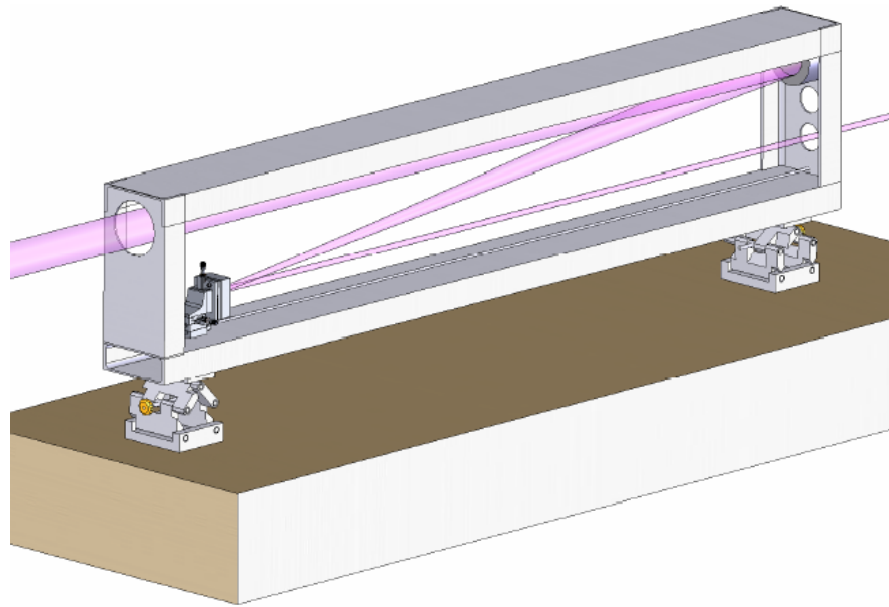

Figure 6: Beam Compressor conceptual design showing two parabolic mirrors with 95mm beam from the output of the delay line being reduced to 13 mm beam for the optical tables.

3.5 ALIGNMENT SYSTEM CONCEPTUAL DESIGN

Automated alignment system design for the MRO Interferometer is presented during this conference [3].

3.6 BEAM COMBINING AREA CONCEPTUAL DESIGN

Similar engineering conceptual designs for the beam turning mirror, fast switchyards and the optical table optics are being worked out. Beam combiner designs for both the fringe tracking combiner and science combiners are being developed. Spectrograph and detectors designs are in process.

4. HARDWARE/SOFTWARE IMPLEMENTATION

For both facility and science, hardware and software implementation plans have been drawn to understand and to facilitate common thinking among engineers. Engineering overview of the implementation plans are presented for various sub-systems of MROI.

4.1 CONVENTIONAL FACILITIES INTERFACE ARCHITECTURE

Planned facility and building utility systems are integrated with conventional facilities control system to provide high level distributed access and control to all subsystems of conventional facilities, including HVAC, fire protection systems, security and access control, lighting control, chilled water, vacuum pumps, compressed air and power systems. The hardware architecture chosen is based on a BACNET with distributed

controllers. Control room monitors running RTC software framework will provide readily accessible information and alarming for these conventional facilities to the operators. Figure 7 shows the block diagram of the proposed conventional facilities control system architecture.

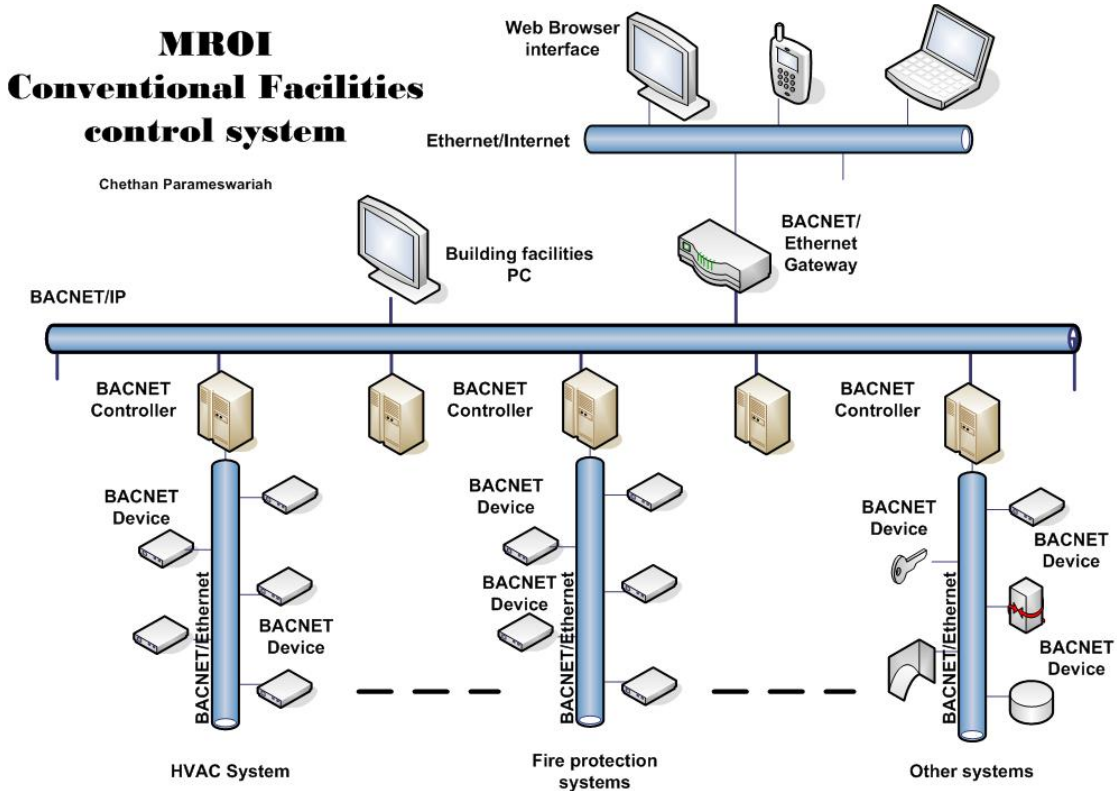

Figure 7: Proposed conventional facilities control system implementation on BACNET interface for HVAC system control, fire alarm and monitoring, and other systems such as vacuum pumps, compressors, power monitoring, chilled water etc.

4.2 COMPUTER INFRASTRUCTURE

MROI computer infrastructure is grouped into three verticals – general computing, controls system, data analysis, each representing specific functions of the observatory. General computing encompasses all general functions of the observatory such as email, web browser, webcams, voip phones and other personal and user services. Control system function is closely related to the engineering and scientific operations of the observatory. This includes all functions for fast real time distributed control, slow control, environmental monitoring, operations and sequencing, control room graphical user interfaces. Data analysis section deals with offline data reduction and processing of science data. The conduit for fiber communication on the ridge is in place with fibers going in when construction starts. The existing radio communication link from the ridge to NMT campus will be augmented with a new high broadband RF link. Figure 8 shows the block diagram of the proposed computer infrastructure implementation.

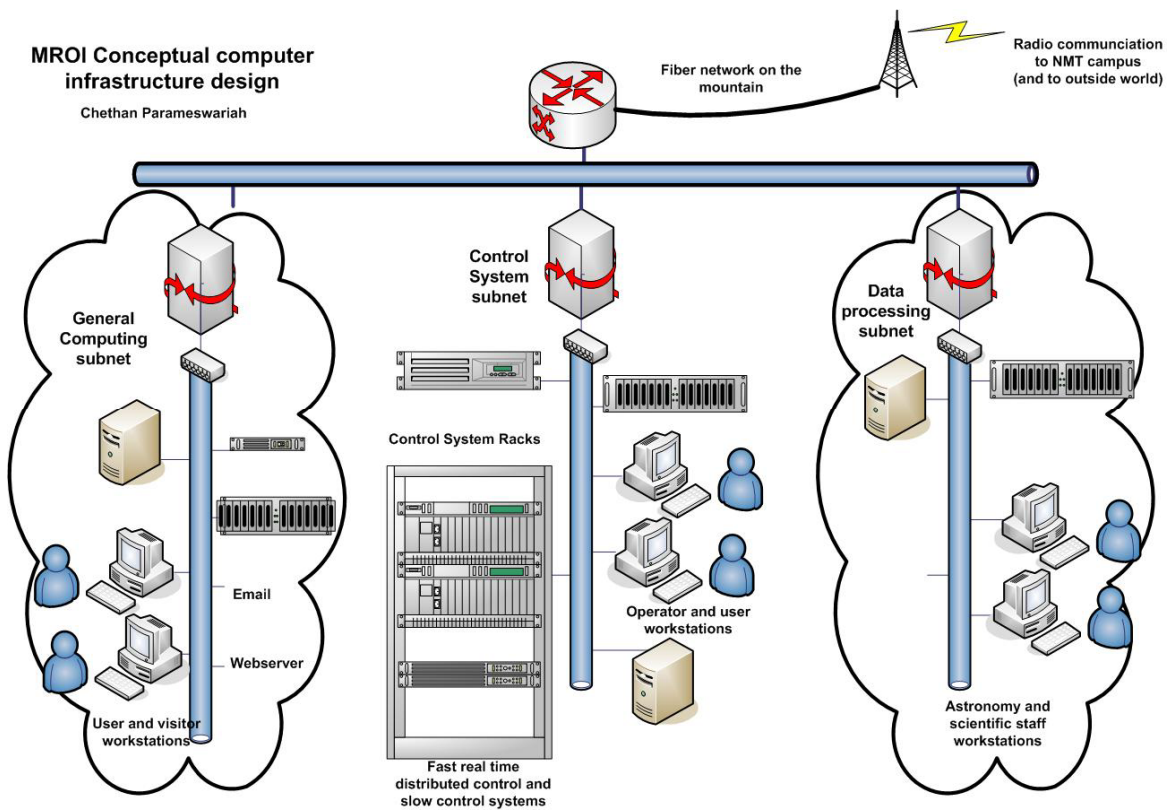

Figure 8: Proposed conceptual computer infrastructure implementation showing three different subnets – real-time distributed control system subnet, general computing subnet, data processing subnet.

4.3 REAL-TIME DISTRIBUTED CONTROL SYSTEM HARDWARE

MROI 10-element imaging interferometer’s proposed hardware implementation to meet the challenging control environment consists of PCI based hardware including real-time control computers, Analog and Digital I/O. Remote distributed devices are implemented with Ethernet ports with Ethernet protocol support. Servo motor controllers for motion control are also designed with Ethernet capability. MROI real-time distributed control system hardware will use an implementation plan comprising mostly COTS (Commercially off the Shelf) hardware to reduce in-house design costs and risks and to speed up implementation. Various hardware devices are being identified to meet the requirements as well as to be compatible with the proposed software implementation plan.

4.4 REAL-TIME DISTRIBUTED CONTROL SOFTWARE

MROI is a complex instrument with a challenging control environment. Real time control is implemented using PCI-based systems with Intel processors running real time Linux. An object oriented software framework “Real Time Control (RTC)” developed at JPL [4] is planned for implementation on top of real time Linux. All systems including long delay lines, beam relay, auto alignment, detector systems and motion control will be designed

with RTC. RTC's use of Common Object Request Broker Architecture (CORBA) provides integrated commanding and telemetry capability and allows for uniform access by various interferometry programs such as configurator, sequencer, automation, GUIs, data archiver. Figure 9 shows a block diagram representation of the software architecture implementation.

MROI Software Architecture Proposed Implementation

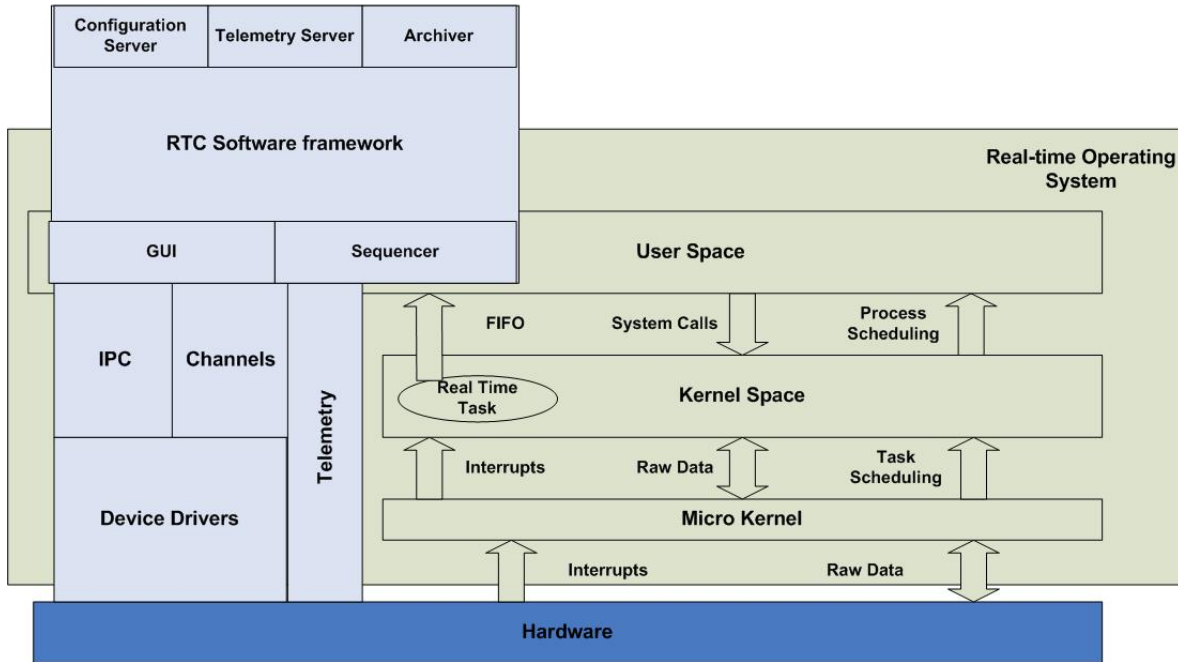

Figure 9: Proposed software architecture implementation showing RTC software framework along with real-time operating system components for the MROI real-time distributed control system.

5 SUMMARY

Magdalena Ridge Observatory Interferometer's overview of engineering conceptual designs is presented. Overview of hardware and software implementations proposed for the interferometer is also described. These designs and proposed implementations are being finalized to final construction designs and will be incorporated as the interferometer is built in the next two years.

6 ACKNOWLEDGEMENTS

Magdalena Ridge Observatory (MRO) is funded by Agreement No. N00173-01-2-C902 with the Naval Research Laboratory (NRL). MRO Interferometer is hosted by New

Mexico Institute of Mining and Technology (NMT) at Socorro, NM, USA, in collaboration with the University of Cambridge (UK). Site and Infrastructure Design and Building conceptual view courtesy of M3 Engineering and Technology Corporation – architects contracted for MROI facility design.

7 REFERENCES

- 1) Magdalena Ridge Observatory Interferometer: status update, Michelle Creech-Eakman, et. al., *Paper No. 6268-70*, this conference.
- 2) Design and Testing of an innovative delay line for the MROI, D.F. Buscher, et. al., *Paper No. 6268-93*, this conference.
- 3) MROI's Automated Alignment System, Colby Jurgenson, et. al., *Paper No. 6268-144*, this conference.
- 4) RTC: a distributed real-time control system toolkit, Lockhart, T, *Proceedings of SPIE, Astronomical and Telescope Instrumentation, Vol. 4848*, 2002